

## Product Preview

# Dual 4-Stage Binary Ripple Counter with $\div 2$ and $\div 5$ Sections

## High-Performance Silicon-Gate CMOS

The MC54/74HC390A is identical in pinout to the LS390. The device inputs are compatible with standard CMOS outputs; with pullup resistors, they are compatible with LSTTL outputs.

This device consists of two independent 4-bit counters, each composed of a divide-by-two and a divide-by-five section. The divide-by-two and divide-by-five counters have separate clock inputs, and can be cascaded to implement various combinations of  $\div 2$  and/or  $\div 5$  up to a  $\div 100$  counter.

Flip-flops internal to the counters are triggered by high-to-low transitions of the clock input. A separate, asynchronous reset is provided for each 4-bit counter. State changes of the Q outputs do not occur simultaneously because of internal ripple delays. Therefore, decoded output signals are subject to decoding spikes and should not be used as clocks or strobes except when gated with the Clock of the HC390A.

- Output Drive Capability: 10 LSTTL Loads
- Outputs Directly Interface to CMOS, NMOS, and TTL
- Operating Voltage Range: 2 to 6 V
- Low Input Current: 1  $\mu$ A
- High Noise Immunity Characteristic of CMOS Devices
- In Compliance with the Requirements Defined by JEDEC Standard No 7A
- Chip Complexity: 244 FETs or 61 Equivalent Gates

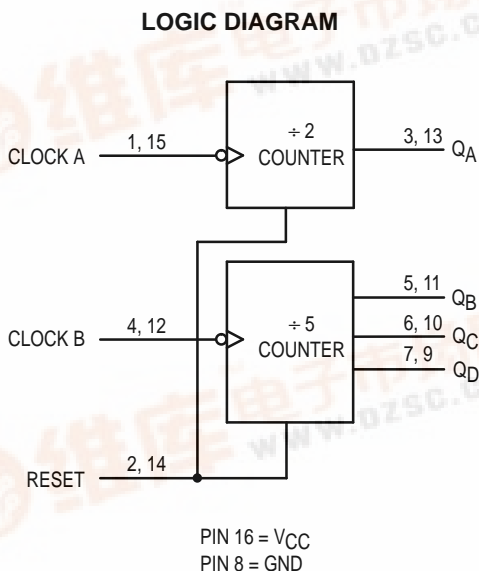

## MC54/74HC390A

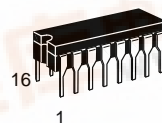

**J SUFFIX**  
 CERAMIC PACKAGE  
 CASE 620-10

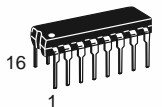

**N SUFFIX**  
 PLASTIC PACKAGE  
 CASE 648-08

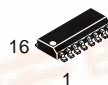

**D SUFFIX**  
 SOIC PACKAGE  
 CASE 751B-05



**DT SUFFIX**  
 TSSOP PACKAGE  
 CASE 948F-01

### ORDERING INFORMATION

MC54HCXXXAJ	Ceramic
MC74HCXXXAN	Plastic
MC74HCXXXAD	SOIC
MC74HCXXXADT	TSSOP

### PIN ASSIGNMENT

CLOCK A <sub>a</sub>	1	16	V <sub>CC</sub>
RESET a	2	15	CLOCK A <sub>b</sub>
Q <sub>Aa</sub>	3	14	RESET b
CLOCK B <sub>a</sub>	4	13	Q <sub>Ab</sub>
Q <sub>Ba</sub>	5	12	CLOCK B <sub>b</sub>
Q <sub>Ca</sub>	6	11	Q <sub>Bb</sub>
Q <sub>Da</sub>	7	10	Q <sub>Cb</sub>
GND	8	9	Q <sub>Db</sub>

### FUNCTION TABLE

Clock		Reset	Action
A	B		
X	X	H	Reset $\div 2$ and $\div 5$
$\sim$	X	L	Increment $\div 2$
X	$\sim$	L	Increment $\div 5$

# MC54/74HC390A

## MAXIMUM RATINGS\*

Symbol	Parameter	Value	Unit
V <sub>CC</sub>	DC Supply Voltage (Referenced to GND)	- 0.5 to + 7.0	V
V <sub>in</sub>	DC Input Voltage (Referenced to GND)	- 0.5 to V <sub>CC</sub> + 0.5	V
V <sub>out</sub>	DC Output Voltage (Referenced to GND)	- 0.5 to V <sub>CC</sub> + 0.5	V
I <sub>in</sub>	DC Input Current, per Pin	± 20	mA
I <sub>out</sub>	DC Output Current, per Pin	± 25	mA
I <sub>CC</sub>	DC Supply Current, V <sub>CC</sub> and GND Pins	± 50	mA
P <sub>D</sub>	Power Dissipation in Still Air, Plastic or Ceramic DIP† SOIC Package† TSSOP Package†	750 500 450	mW
T <sub>stg</sub>	Storage Temperature	- 65 to + 150	°C
T <sub>L</sub>	Lead Temperature, 1 mm from Case for 10 Seconds Plastic DIP, SOIC or TSSOP Package (Ceramic DIP)	260 300	°C

This device contains protection circuitry to guard against damage due to high static voltages or electric fields. However, precautions must be taken to avoid applications of any voltage higher than maximum rated voltages to this high-impedance circuit. For proper operation, V<sub>in</sub> and V<sub>out</sub> should be constrained to the range GND ≤ (V<sub>in</sub> or V<sub>out</sub>) ≤ V<sub>CC</sub>. Unused inputs must always be tied to an appropriate logic voltage level (e.g., either GND or V<sub>CC</sub>). Unused outputs must be left open.

\* Maximum Ratings are those values beyond which damage to the device may occur. Functional operation should be restricted to the Recommended Operating Conditions.

†Derating — Plastic DIP: - 10 mW/°C from 65° to 125°C  
Ceramic DIP: - 10 mW/°C from 100° to 125°C  
SOIC Package: - 7 mW/°C from 65° to 125°C  
TSSOP Package: - 6.1 mW/°C from 65° to 125°C

For high frequency or heavy load considerations, see Chapter 2 of the Motorola High-Speed CMOS Data Book (DL129/D).

## RECOMMENDED OPERATING CONDITIONS

Symbol	Parameter	Min	Max	Unit
V <sub>CC</sub>	DC Supply Voltage (Referenced to GND)	2.0	6.0	V
V <sub>in</sub> , V <sub>out</sub>	DC Input Voltage, Output Voltage (Referenced to GND)	0	V <sub>CC</sub>	V
T <sub>A</sub>	Operating Temperature, All Package Types	- 55	+ 125	°C
t <sub>r</sub> , t <sub>f</sub>	Input Rise and Fall Time (Figure 1)	V <sub>CC</sub> = 2.0 V 0 V <sub>CC</sub> = 3.0 V 0 V <sub>CC</sub> = 4.5 V 0 V <sub>CC</sub> = 6.0 V	1000 600 500 400	ns

## DC ELECTRICAL CHARACTERISTICS (Voltages Referenced to GND)

Symbol	Parameter	Test Conditions	V <sub>CC</sub> V	Guaranteed Limit			Unit
				- 55 to 25°C	≤ 85°C	≤ 125°C	
V <sub>IH</sub>	Minimum High-Level Input Voltage	V <sub>out</sub> = 0.1 V or V <sub>CC</sub> - 0.1 V  I <sub>out</sub>   ≤ 20 μA	2.0	1.5	1.5	1.5	V
			3.0	2.1	2.1	2.1	
			4.5	3.15	3.15	3.15	
			6.0	4.2	4.2	4.2	
V <sub>IL</sub>	Maximum Low-Level Input Voltage	V <sub>out</sub> = 0.1 V or V <sub>CC</sub> - 0.1 V  I <sub>out</sub>   ≤ 20 μA	2.0	0.5	0.5	0.5	V
			3.0	0.9	0.9	0.9	
			4.5	1.35	1.35	1.35	
			6.0	1.8	1.8	1.8	
V <sub>OH</sub>	Minimum High-Level Output Voltage	V <sub>in</sub> = V <sub>IH</sub> or V <sub>IL</sub>  I <sub>out</sub>   ≤ 20 μA	2.0	1.9	1.9	1.9	V
			4.5	4.4	4.4	4.4	
			6.0	5.9	5.9	5.9	
		V <sub>in</sub> = V <sub>IH</sub> or V <sub>IL</sub>  I <sub>out</sub>   ≤ 2.4 mA  I <sub>out</sub>   ≤ 4.0 mA  I <sub>out</sub>   ≤ 5.2 mA	3.0	2.48	2.34	2.20	
			4.5	3.98	3.84	3.70	
			6.0	5.48	5.34	5.20	

**DC ELECTRICAL CHARACTERISTICS** (Voltages Referenced to GND)

Symbol	Parameter	Test Conditions	V <sub>CC</sub> V	Guaranteed Limit			Unit
				- 55 to 25°C	≤ 85°C	≤ 125°C	
V <sub>OL</sub>	Maximum Low-Level Output Voltage	V <sub>in</sub> = V <sub>IH</sub> or V <sub>IL</sub>  I <sub>out</sub>   ≤ 20 μA	2.0	0.1	0.1	0.1	V
			4.5	0.1	0.1	0.1	
		6.0	0.1	0.1	0.1		
		V <sub>in</sub> = V <sub>IH</sub> or V <sub>IL</sub>  I <sub>out</sub>   ≤ 2.4 mA  I <sub>out</sub>   ≤ 4.0 mA  I <sub>out</sub>   ≤ 5.2 mA	3.0	0.26	0.33	0.40	
4.5	0.26		0.33	0.40			
6.0	0.26		0.33	0.40			
I <sub>in</sub>	Maximum Input Leakage Current	V <sub>in</sub> = V <sub>CC</sub> or GND	6.0	± 0.1	± 1.0	± 1.0	μA
I <sub>CC</sub>	Maximum Quiescent Supply Current (per Package)	V <sub>in</sub> = V <sub>CC</sub> or GND I <sub>out</sub> = 0 μA	6.0	4	40	160	μA

NOTE: Information on typical parametric values can be found in Chapter 2 of the Motorola High-Speed CMOS Data Book (DL129/D).

**AC ELECTRICAL CHARACTERISTICS** (C<sub>L</sub> = 50 pF, Input t<sub>f</sub> = t<sub>r</sub> = 6 ns)

Symbol	Parameter	V <sub>CC</sub> V	Guaranteed Limit			Unit
			- 55 to 25°C	≤ 85°C	≤ 125°C	
f <sub>max</sub>	Maximum Clock Frequency (50% Duty Cycle) (Figures 1 and 3)	2.0	10	9	8	MHz
		3.0	15	14	12	
		4.5	30	28	25	
		6.0	50	45	40	
t <sub>PLH</sub> , t <sub>PHL</sub>	Maximum Propagation Delay, Clock A to QA (Figures 1 and 3)	2.0	70	80	90	ns
		3.0	40	45	50	
		4.5	20	25	30	
		6.0	16	21	27	
t <sub>PLH</sub> , t <sub>PHL</sub>	Maximum Propagation Delay, Clock A to QC (QA connected to Clock B) (Figures 1 and 3)	2.0	200	250	300	ns
		3.0	160	185	210	
		4.5	35	45	60	
		6.0	30	40	50	
t <sub>PLH</sub> , t <sub>PHL</sub>	Maximum Propagation Delay, Clock B to QB (Figures 1 and 3)	2.0	70	80	90	ns
		3.0	40	45	50	
		4.5	20	25	30	
		6.0	16	21	27	
t <sub>PLH</sub> , t <sub>PHL</sub>	Maximum Propagation Delay, Clock B to QC (Figures 1 and 3)	2.0	90	105	180	ns
		3.0	56	70	100	
		4.5	32	38	45	
		6.0	25	31	40	
t <sub>PLH</sub> , t <sub>PHL</sub>	Maximum Propagation Delay, Clock B to QD (Figures 1 and 3)	2.0	70	80	90	ns
		3.0	40	45	50	
		4.5	20	25	30	
		6.0	16	21	27	
t <sub>PHL</sub>	Maximum Propagation Delay, Reset to any Q (Figures 2 and 3)	2.0	80	95	110	ns
		3.0	48	65	75	
		4.5	28	32	40	
		6.0	21	25	30	

# MC54/74HC390A

## AC ELECTRICAL CHARACTERISTICS (C<sub>L</sub> = 50 pF, Input t<sub>r</sub> = t<sub>f</sub> = 6 ns)

Symbol	Parameter	V <sub>CC</sub> V	Guaranteed Limit			Unit
			- 55 to 25°C	≤ 85°C	≤ 125°C	
t <sub>TLH</sub> , t <sub>THL</sub>	Maximum Output Transition Time, Any Output (Figures 1 and 3)	2.0	75	95	110	ns
		3.0	27	32	36	
		4.5	15	19	22	
		6.0	13	15	19	
C <sub>in</sub>	Maximum Input Capacitance	—	10	10	10	pF

### NOTES:

- For propagation delays with loads other than 50 pF, see Chapter 2 of the Motorola High-Speed CMOS Data Book (DL129/D).
- Information on typical parametric values can be found in Chapter 2 of the Motorola High-Speed CMOS Data Book (DL129/D).

CPD	Power Dissipation Capacitance (Per Counter)*	Typical @ 25°C, V <sub>CC</sub> = 5.0 V		pF
		35		

\* Used to determine the no-load dynamic power consumption:  $P_D = C_{PD} V_{CC}^2 f + I_{CC} V_{CC}$ . For load considerations, see Chapter 2 of the Motorola High-Speed CMOS Data Book (DL129/D).

## TIMING REQUIREMENTS (Input t<sub>r</sub> = t<sub>f</sub> = 6 ns)

Symbol	Parameter	V <sub>CC</sub> V	Guaranteed Limit			Unit
			- 55 to 25°C	≤ 85°C	≤ 125°C	
t <sub>rec</sub>	Minimum Recovery Time, Reset Inactive to Clock A or Clock B (Figure 2)	2.0	25	30	40	ns
		3.0	15	20	30	
		4.5	5	6	10	
		6.0	5	5	7	
t <sub>w</sub>	Minimum Pulse Width, Clock A, Clock B (Figure 1)	2.0	75	95	110	ns
		3.0	27	32	36	
		4.5	15	19	22	
		6.0	13	15	19	
t <sub>w</sub>	Minimum Pulse Width, Reset (Figure 2)	2.0	75	95	110	ns
		3.0	27	32	36	
		4.5	15	19	22	
		6.0	13	15	19	
t <sub>r</sub> , t <sub>f</sub>	Maximum Input Rise and Fall Times (Figure 1)	2.0	1000	1000	1000	ns
		3.0	800	800	800	
		4.5	500	500	500	
		6.0	400	400	400	

NOTE: Information on typical parametric values can be found in Chapter 2 of the Motorola High-Speed CMOS Data Book (DL129/D).

**PIN DESCRIPTIONS**

**INPUTS**

**Clock A (Pins 1, 15) and Clock B (Pins 4, 15)**

Clock A is the clock input to the ÷ 2 counter; Clock B is the clock input to the ÷ 5 counter. The internal flip-flops are toggled by high-to-low transitions of the clock input.

**CONTROL INPUTS**

**Reset (Pins 2, 14)**

Asynchronous reset. A high at the Reset input prevents counting, resets the internal flip-flops, and forces Q<sub>A</sub> through Q<sub>D</sub> low.

**OUTPUTS**

**Q<sub>A</sub> (Pins 3, 13)**

Output of the ÷ 2 counter.

**Q<sub>B</sub>, Q<sub>C</sub>, Q<sub>D</sub> (Pins 5, 6, 7, 9, 10, 11)**

Outputs of the ÷ 5 counter. Q<sub>D</sub> is the most significant bit. Q<sub>A</sub> is the least significant bit when the counter is connected for BCD output as in Figure 4. Q<sub>B</sub> is the least significant bit when the counter is operating in the bi-quinary mode as in Figure 5.

**SWITCHING WAVEFORMS**

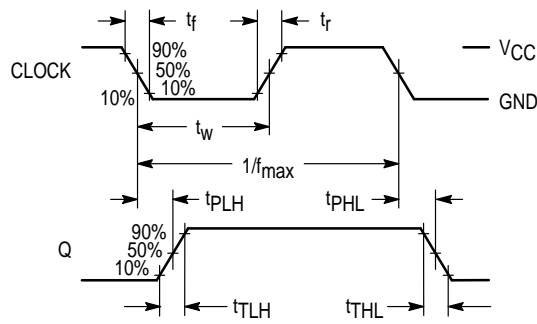

Figure 1.

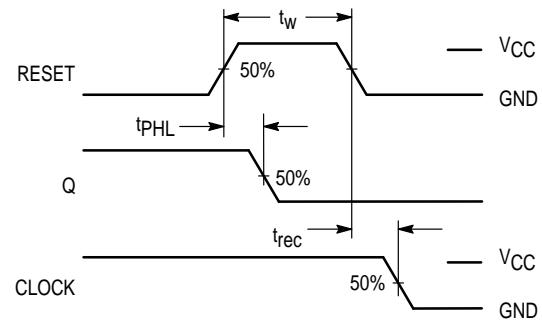
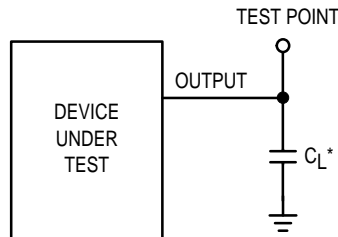

Figure 2.

**TEST CIRCUIT**



\* Includes all probe and jig capacitance

Figure 3.

# MC54/74HC390A

## EXPANDED LOGIC DIAGRAM

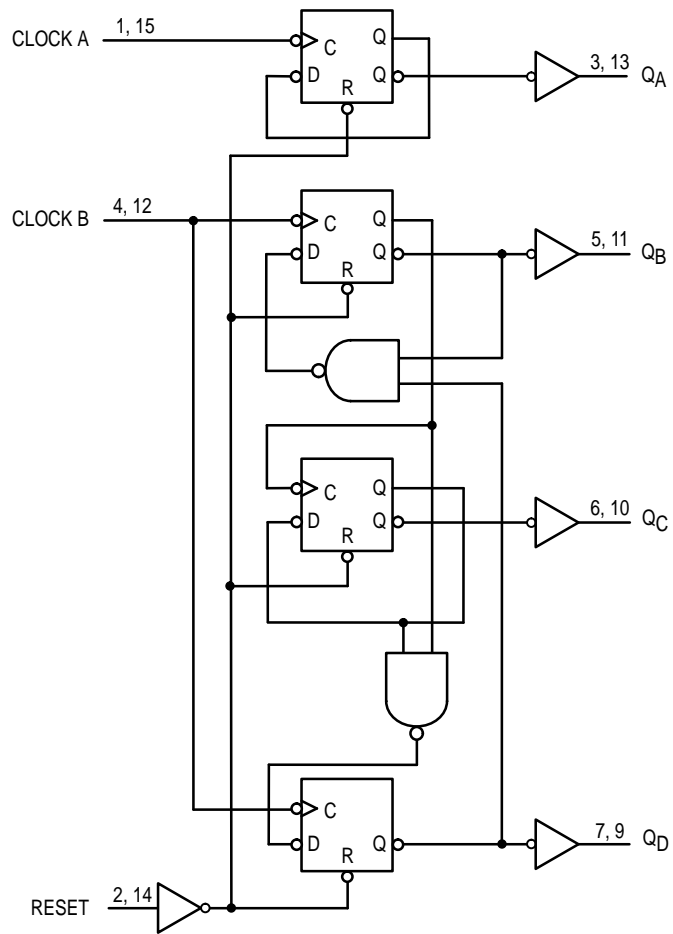

## TIMING DIAGRAM (QA Connected to Clock B)

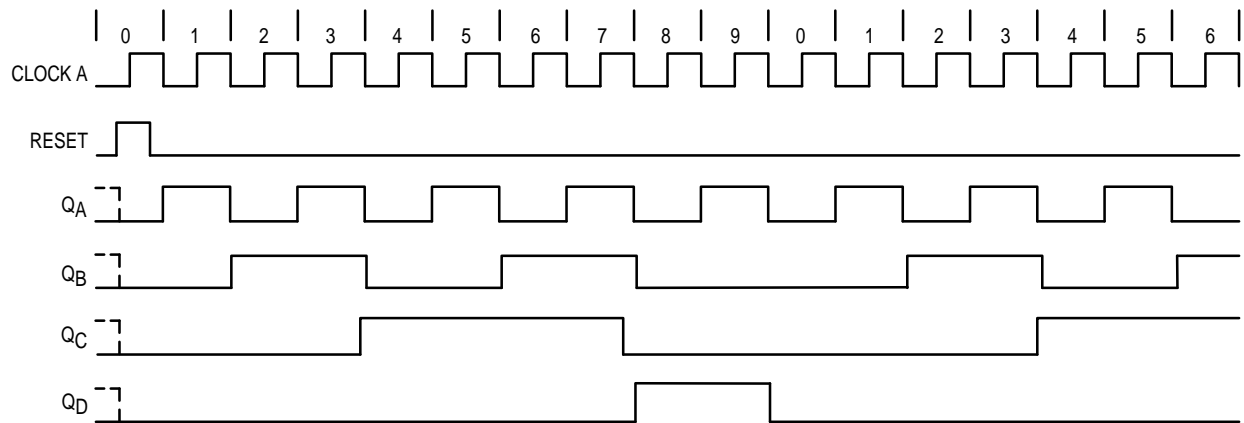

**APPLICATIONS INFORMATION**

Each half of the MC54/74HC390A has independent ÷ 2 and ÷ 5 sections (except for the Reset function). The ÷ 2 and ÷ 5 counters can be connected to give BCD or bi-quinary (2–5) count sequences. If Output Q<sub>A</sub> is connected to the Clock B input (Figure 4), a decade divider with BCD output is obtained. The function table for the BCD count sequence is given in Table 1.

To obtain a bi-quinary count sequence, the input signals connected to the Clock B input, and output Q<sub>D</sub> is connected to the Clock A input (Figure 5). Q<sub>A</sub> provides a 50% duty cycle output. The bi-quinary count sequence function table is given in Table 2.

**Table 1. BCD Count Sequence\***

Count	Output			
	Q <sub>D</sub>	Q <sub>C</sub>	Q <sub>B</sub>	Q <sub>A</sub>
0	L	L	L	L
1	L	L	L	H
2	L	L	H	L
3	L	L	H	H
4	L	H	L	L
5	L	H	L	H
6	L	H	H	L
7	L	H	H	H
8	H	L	L	L
9	H	L	L	H

\* Q<sub>A</sub> connected to Clock B input.

**Table 2. Bi-Quinary Count Sequence\*\***

Count	Output			
	Q <sub>A</sub>	Q <sub>D</sub>	Q <sub>C</sub>	Q <sub>B</sub>
0	L	L	L	L
1	L	L	L	H
2	L	L	H	L
3	L	L	H	H
4	L	H	L	L
8	H	L	L	L
9	H	L	L	H
10	H	L	H	L
11	H	L	H	H
12	H	H	L	L

\*\* Q<sub>D</sub> connected to Clock A input.

**CONNECTION DIAGRAMS**

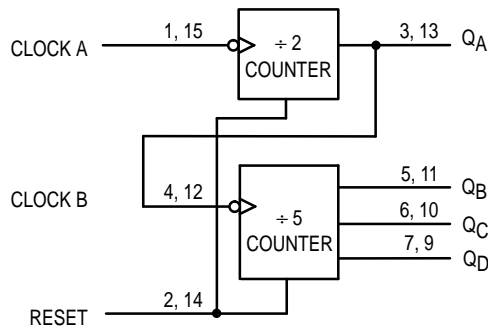

**Figure 4. BCD Count**

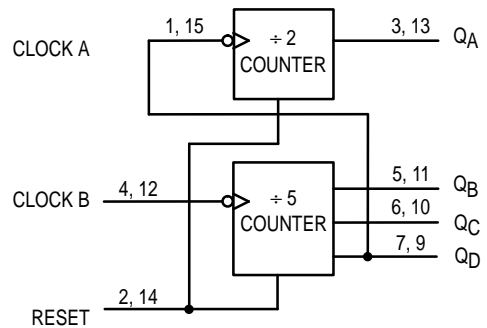

**Figure 5. Bi-Quinary Count**

OUTLINE DIMENSIONS

**J SUFFIX**  
CERAMIC PACKAGE  
CASE 620-10  
ISSUE V

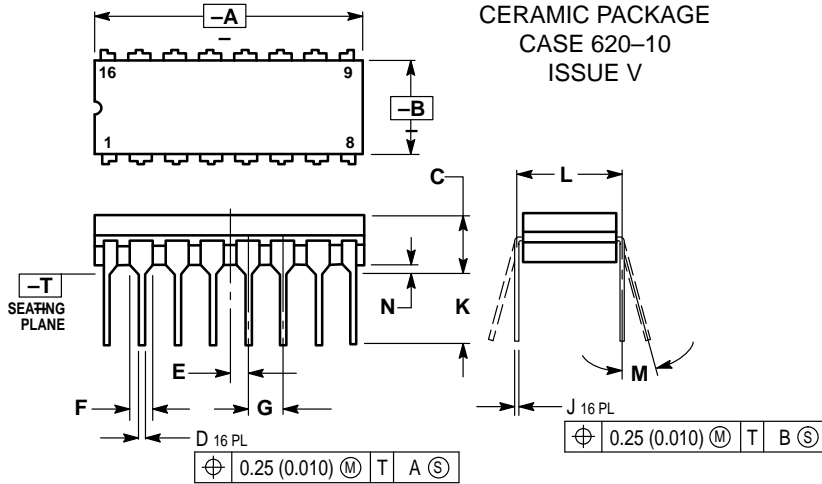

- NOTES:
1. DIMENSIONING AND TOLERANCING PER ANSI Y14.5M, 1982.
  2. CONTROLLING DIMENSION: INCH.
  3. DIMENSION L TO CENTER OF LEAD WHEN FORMED PARALLEL.
  4. DIM F MAY NARROW TO 0.76 (0.030) WHERE THE LEAD ENTERS THE CERAMIC BODY.

DIM	INCHES		MILLIMETERS	
	MIN	MAX	MIN	MAX
A	0.750	0.785	19.05	19.93
B	0.240	0.295	6.10	7.49
C	—	0.200	—	5.08
D	0.015	0.020	0.39	0.50
E	0.050 BSC		1.27 BSC	
F	0.055	0.065	1.40	1.65
G	0.100 BSC		2.54 BSC	
J	0.008	0.015	0.21	0.38
K	0.125	0.170	3.18	4.31
L	0.300 BSC		7.62 BSC	
M	0°	15°	0°	15°
N	0.020	0.040	0.51	1.01

**N SUFFIX**  
PLASTIC PACKAGE  
CASE 648-08  
ISSUE R

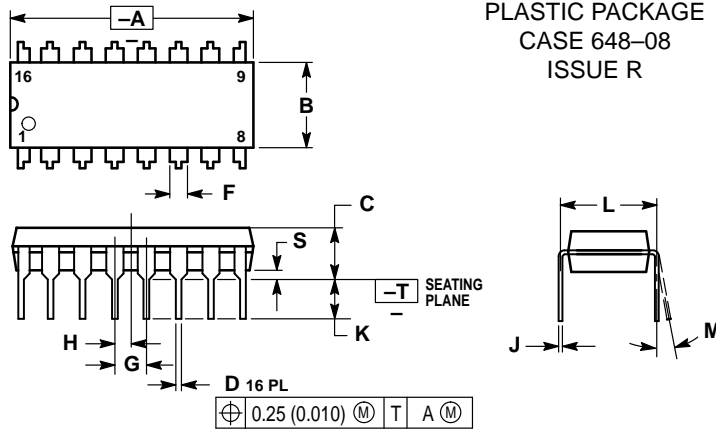

- NOTES:
1. DIMENSIONING AND TOLERANCING PER ANSI Y14.5M, 1982.
  2. CONTROLLING DIMENSION: INCH.
  3. DIMENSION L TO CENTER OF LEADS WHEN FORMED PARALLEL.
  4. DIMENSION B DOES NOT INCLUDE MOLD FLASH.
  5. ROUNDED CORNERS OPTIONAL.

DIM	INCHES		MILLIMETERS	
	MIN	MAX	MIN	MAX
A	0.740	0.770	18.80	19.55
B	0.250	0.270	6.35	6.85
C	0.145	0.175	3.69	4.44
D	0.015	0.021	0.39	0.53
F	0.040	0.070	1.02	1.77
G	0.100 BSC		2.54 BSC	
H	0.050 BSC		1.27 BSC	
J	0.008	0.015	0.21	0.38
K	0.110	0.130	2.80	3.30
L	0.295	0.305	7.50	7.74
M	0°	10°	0°	10°
S	0.020	0.040	0.51	1.01

**D SUFFIX**  
PLASTIC SOIC PACKAGE  
CASE 751B-05  
ISSUE J

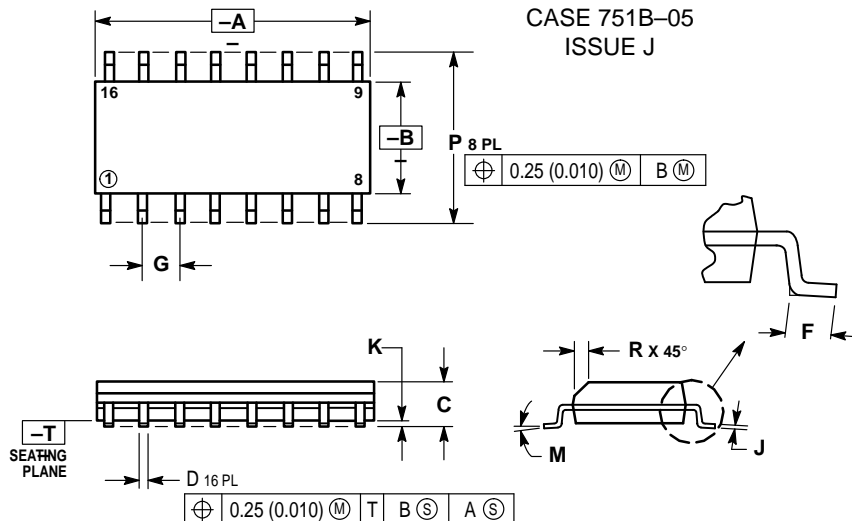

- NOTES:
1. DIMENSIONING AND TOLERANCING PER ANSI Y14.5M, 1982.
  2. CONTROLLING DIMENSION: MILLIMETER.
  3. DIMENSIONS A AND B DO NOT INCLUDE MOLD PROTRUSION.
  4. MAXIMUM MOLD PROTRUSION 0.15 (0.006) PER SIDE.
  5. DIMENSION D DOES NOT INCLUDE DAMBAR PROTRUSION. ALLOWABLE DAMBAR PROTRUSION SHALL BE 0.127 (0.005) TOTAL IN EXCESS OF THE D DIMENSION AT MAXIMUM MATERIAL CONDITION.

DIM	MILLIMETERS		INCHES	
	MIN	MAX	MIN	MAX
A	9.80	10.00	0.386	0.393
B	3.80	4.00	0.150	0.157
C	1.35	1.75	0.054	0.068
D	0.35	0.49	0.014	0.019
F	0.40	1.25	0.016	0.049
G	1.27 BSC		0.050 BSC	
J	0.19	0.25	0.008	0.009
K	0.10	0.25	0.004	0.009
M	0°	7°	0°	7°
P	5.80	6.20	0.229	0.244
R	0.25	0.50	0.010	0.019



OUTLINE DIMENSIONS

DT SUFFIX  
PLASTIC TSSOP PACKAGE  
CASE 948F-01  
ISSUE O

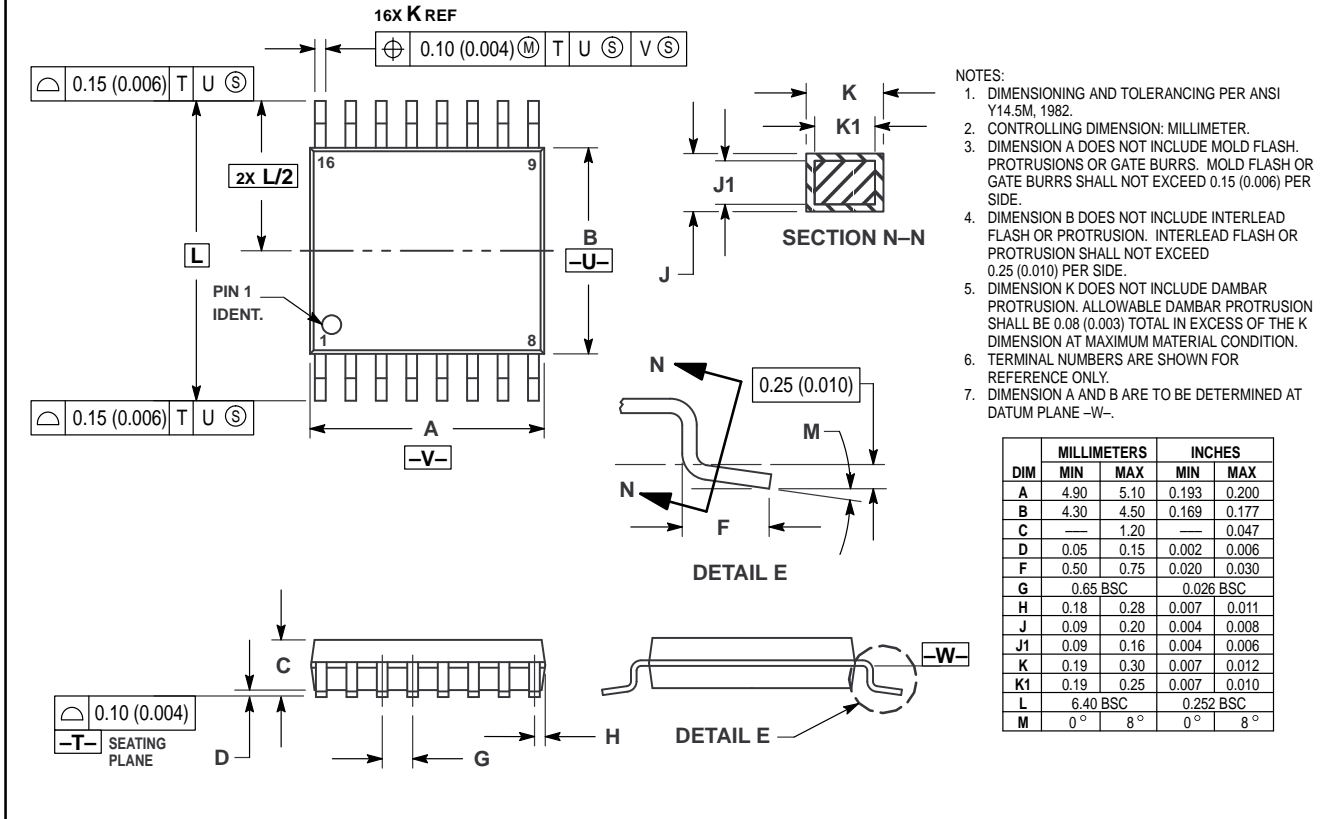

Motorola reserves the right to make changes without further notice to any products herein. Motorola makes no warranty, representation or guarantee regarding the suitability of its products for any particular purpose, nor does Motorola assume any liability arising out of the application or use of any product or circuit, and specifically disclaims any and all liability, including without limitation consequential or incidental damages. "Typical" parameters can and do vary in different applications. All operating parameters, including "Typicals" must be validated for each customer application by customer's technical experts. Motorola does not convey any license under its patent rights nor the rights of others. Motorola products are not designed, intended, or authorized for use as components in systems intended for surgical implant into the body, or other applications intended to support or sustain life, or for any other application in which the failure of the Motorola product could create a situation where personal injury or death may occur. Should Buyer purchase or use Motorola products for any such unintended or unauthorized application, Buyer shall indemnify and hold Motorola and its officers, employees, subsidiaries, affiliates, and distributors harmless against all claims, costs, damages, and expenses, and reasonable attorney fees arising out of, directly or indirectly, any claim of personal injury or death associated with such unintended or unauthorized use, even if such claim alleges that Motorola was negligent regarding the design or manufacture of the part. Motorola and are registered trademarks of Motorola, Inc. Motorola, Inc. is an Equal Opportunity/Affirmative Action Employer.

**How to reach us:**  
**USA/EUROPE:** Motorola Literature Distribution;  
 P.O. Box 20912; Phoenix, Arizona 85036. 1-800-441-2447

**JAPAN:** Nippon Motorola Ltd.; Tatsumi-SPD-JLDC, Toshikatsu Otsuki,  
 6F Seibu-Butsuryu-Center, 3-14-2 Tatsumi Koto-Ku, Tokyo 135, Japan. 03-3521-8315

**MFAX:** RMFAX0@email.sps.mot.com -TOUCHTONE (602) 244-6609  
**INTERNET:** http://Design-NET.com

**HONG KONG:** Motorola Semiconductors H.K. Ltd.; 8B Tai Ping Industrial Park,  
 51 Ting Kok Road, Tai Po, N.T., Hong Kong. 852-26629298

