

Fixed Code Encoder

FEATURES

Operating

- 2 Programmable 32-bit serial numbers
- 10-bit serial number
- 66-bit transmission code length
- Non-volatile 16-bit counter
- 3.5V -13.3V operation
- 3 inputs, 7 functions available
- Selectable baud rate
- Automatic code word completion
- Battery low signal transmitted to receiver

Other

- Pin-out compatible with most KEELOQ® Encoders
- Simple programming interface
- On-chip EEPROM
- On-chip oscillator and timing components
- Button inputs have internal pull-down resistors
- Minimum External Components required

Typical Applications

The HCS101 is ideal for remote control applications. These applications include:

- Low-end automotive alarm systems
- Low-end automotive immobilizers
- Gate and garage door openers
- Identity tokens
- Low-end burglar alarm systems
- Fan and lighting controls
- Toys

DESCRIPTION

The HCS101 from Microchip Technology Inc. is a fixed code encoder designed for remote control systems. It provides a small package outline and low cost to make this device a perfect solution for unidirectional remote control systems.

It is also pin compatible with Microchip's HCS201 Code Hopping Encoder allowing easy upgrading to a more secure remote keyless entry (RKE) system.

The 8-pin HCS101 operates over a wide voltage range of 3.5V to 13.3V and has three button inputs allowing the system designer the freedom to utilize up to 7 functions. The only components required for device operation are the buttons and RF circuitry, allowing a very low system cost.

PACKAGE TYPES

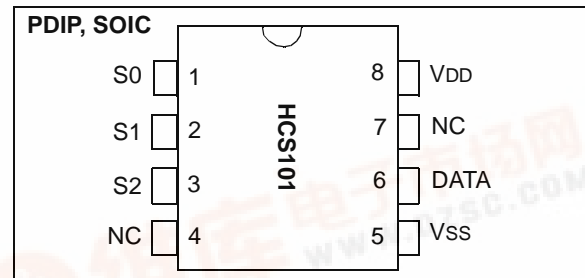

HCS101 BLOCK DIAGRAM

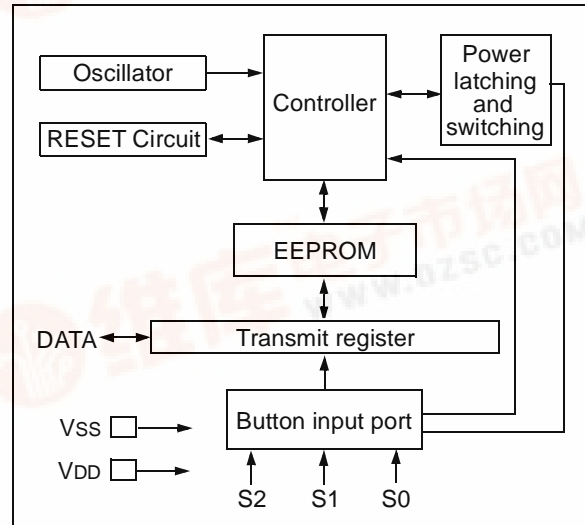

HCS101

[查询HCS101供应商](#)

1.0 SYSTEM OVERVIEW

As indicated in the block diagram in Figure 1-1, the HCS101 has a small EEPROM array, which must be loaded with several parameters before use. These parameters include:

- Two 32-bit serial numbers
- 16-bit counter value
- Additional 10-bit serial number
- Configuration data

The EEPROM data for each transmitter is programmed by the manufacturer at the time of production.

Any type of controller may be used as a receiver, but it is typically a microcontroller with compatible firmware that allows the receiver to operate in conjunction with a transmitter, based on the HCS101.

FIGURE 1-1: BASIC OPERATION OF TRANSMITTER ENCODER

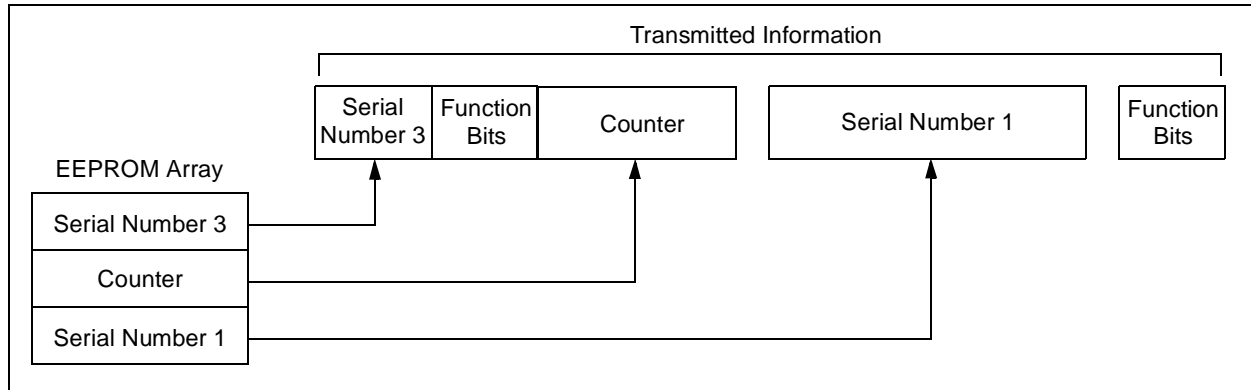

2.0 DEVICE OPERATION

As shown in the typical application circuits in Figure 2-1, the HCS101 is easy to use. It requires only the addition of buttons and RF circuitry for use as the transmitter in your application. A description of each pin is given in Table 2-1.

FIGURE 2-1: TYPICAL CIRCUITS

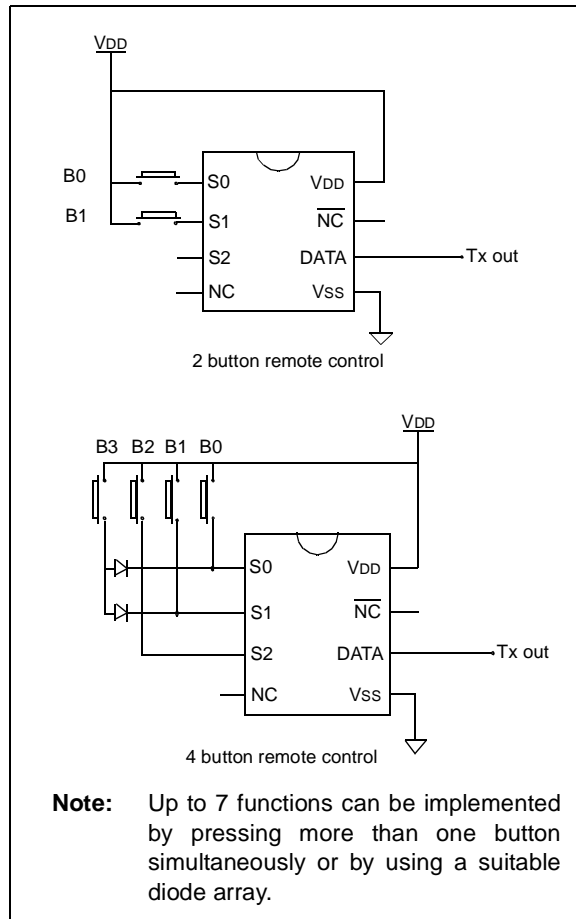

TABLE 2-1: PIN DESCRIPTIONS

Name	Pin Number	Description
S0	1	Switch input 0
S1	2	Switch input 1
S2	3	Switch input 2/Clock pin for Programming mode
NC	4	No connection
VSS	5	Ground reference connection
DATA	6	Pulse Width Modulation (PWM) output pin/Data pin for Programming mode
NC	7	No connection
VDD	8	Positive supply voltage connection

The HCS101 will wake-up upon detecting a switch closure and then delay for a debounce delay (T_{DB}) as shown in Figure 2-2. The device will then update the 16-bit counter before it loads the transmit register. The data is then transmitted serially on the DATA pin in Pulse Width Modulation (PWM) format.

If additional buttons are pressed during a transmission, the current transmission is terminated. The HCS101 restarts and the new transmission will contain the latest button information. When all buttons are released, the device completes the current code word and then powers down. Released buttons do not terminate and/or restart transmissions.

FIGURE 2-2: ENCODER OPERATION

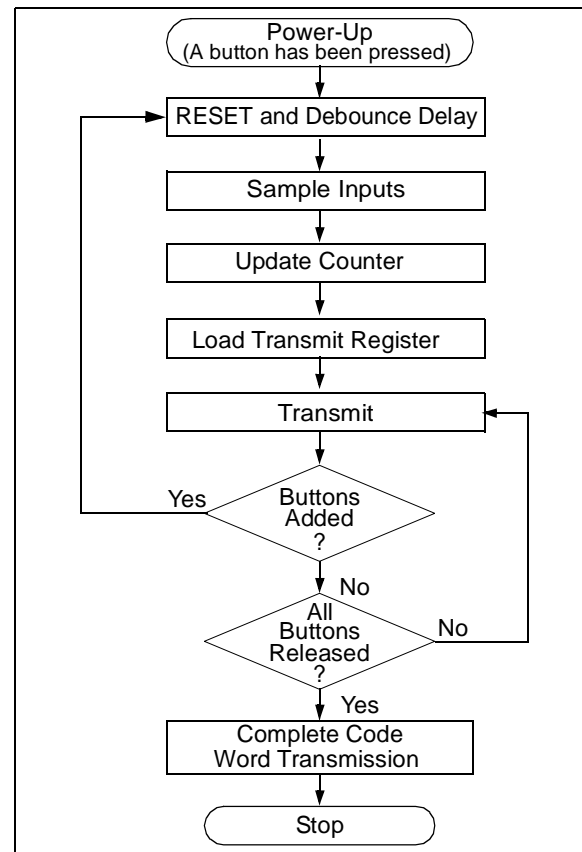

HCS101

[查询HCS101供应商](#)

3.0 TRANSMITTED WORD

3.1 Transmission Format (PWM Mode)

The HCS101 transmission is made up of several code words as shown in Figure 3-1. Each code word starts with a preamble and a header, followed by the data. The code word is followed by a guard period before the next code word begins. The same code word is transmitted as long as the button is pressed. Refer to Table 7-3 for transmission timing requirements.

3.2 Code Word Organization

The HCS101 transmits a 66-bit code word. The 66-bit word is constructed from the serial numbers, counter and function information. The code word format is shown in Figure 3-2.

Under normal conditions, serial number 1 is transmitted with the counter and serial number 3. If all the buttons are pressed, serial number 2 is transmitted in place of the counter and serial number 3.

FIGURE 3-1: CODE WORD TRANSMISSION FORMAT

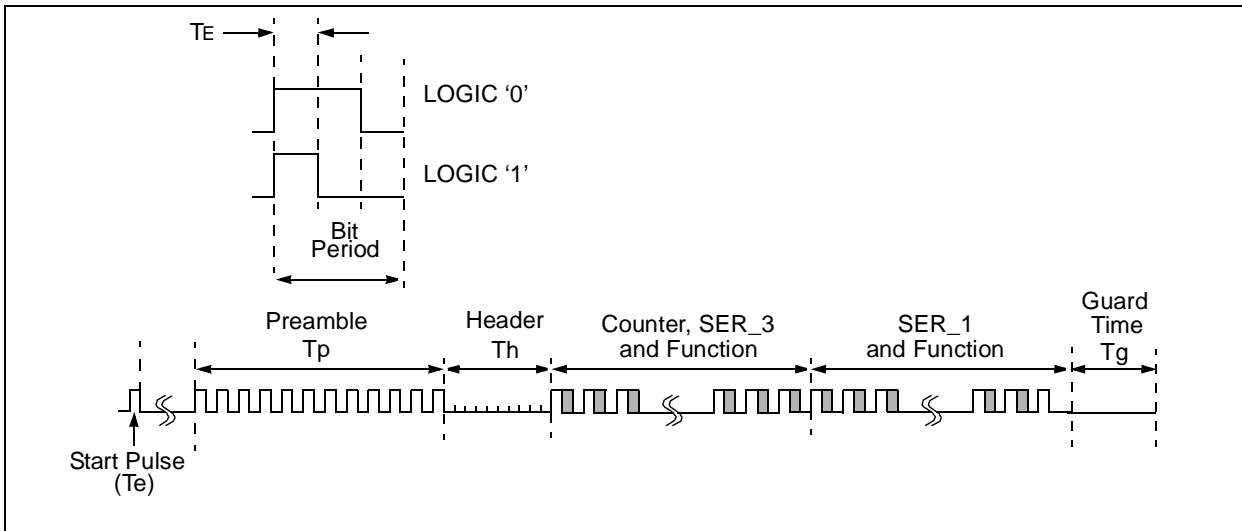
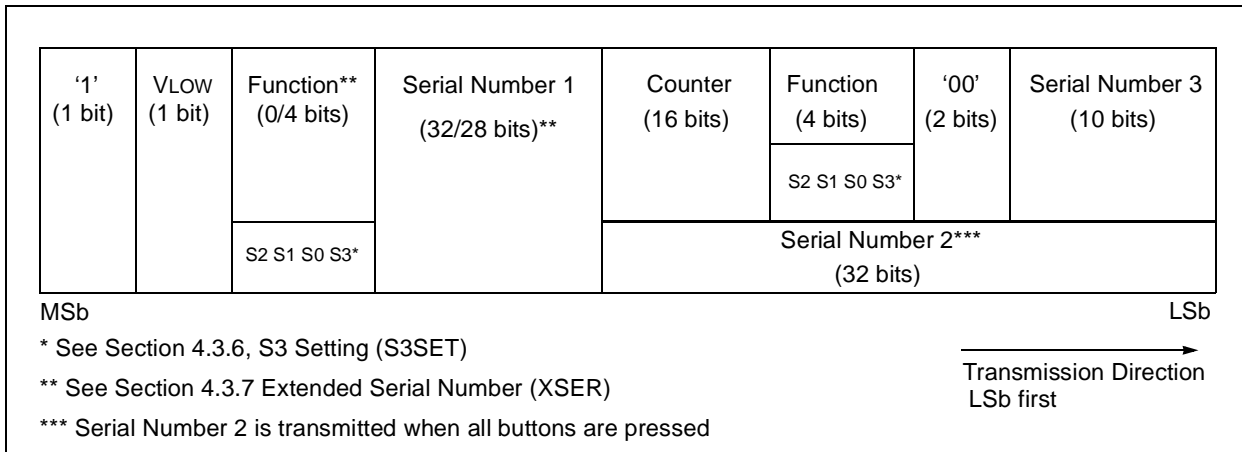

FIGURE 3-2: CODE WORD ORGANIZATION



4.0 EEPROM MEMORY ORGANIZATION

The HCS101 contains 192 bits (12 x 16-bit words) of EEPROM memory as shown in Table 4-1. Further descriptions of the memory array are given in the following sections.

TABLE 4-1: EEPROM MEMORY MAP

WORD ADDRESS	MNEMONIC	DESCRIPTION
0	RESERVED	Set to 0000H
1	RESERVED	Set to 0000H
2	RESERVED	Set to 0000H
3	RESERVED	Set to 0000H
4	CNTR	Counter
5	RESERVED	Set to 0000H
6	SER_1	Device Serial Number 1 (word 0) 16 LSB's
7	SER_1	Device Serial Number 1 (word 1) 16 MSB's
8	SER_2	Device Serial Number 2 (word 0) 16 LSB's
9	SER_2	Device Serial Number 2 (word 1) 16 MSB's
10	SER_3	Device Serial Number 3
11	CONFIG	Config Word

4.1 CNTR (Counter)

This is the 16-bit gray code counter value that can be used to track the number of times a transmitter has been activated.

4.2 SER_1, SER_2, SER_3 (Encoder Serial Number)

SER_1, and SER_2 are the 32-bit device serial numbers. SER_3 is an additional 10-bit serial number transmitted with every transmission. The most significant 6 bits of the 16-bit SER_3 word are reserved and should be set to zero.

4.3 Configuration Word

The configuration word is a 16-bit word stored in the EEPROM array that is used by the device to store the status configuration options. Further explanations of each of the bits are described in the following sections.

TABLE 4-2: CONFIGURATION WORD

Bit Number	Bit Name
0	OSC0
1	OSC1
2	OSC2
3	OSC3
4	VLOWS
5	BRS
6	MTX4
7	TXEN
8	S3SET
9	XSER
10	RESERVED
11	RESERVED
12	RESERVED
13	RESERVED
14	RESERVED
15	RESERVED

4.3.1 OSCILLATOR TUNING BITS (OSC0 TO OSC3)

These bits are used to tune the nominal frequency of the HCS101 to within $\pm 10\%$ of its nominal value over temperature and voltage.

4.3.2 LOW VOLTAGE TRIP POINT SELECT (VLOWS)

The low voltage trip point select bit (VLOWS) and the S3 setting bit (S3SET) are used to determine the voltage level for the low voltage detector.

VLOWS	S3SET*	Trip Point
0	0	4.4
0	1	4.4
1	0	9
1	1	6.75

* See also Section 4.3.6

4.3.3 BAUDRATE SELECT BITS (BRS)

BRS selects the speed of transmission and the code word blanking. Table 4-3 shows how the bit is used to select the different baud rates and Section 5.2 provides a detailed explanation of code word blanking.

TABLE 4-3: BAUDRATE SELECT

BRS	Basic Pulse Element	Code Words Transmitted
0	400 μ s	All
1	200 μ s	1 out of 2

HCS101

[查询HCS101供应商](#)

4.3.4 MINIMUM FOUR TRANSMISSIONS (MTX4)

If this bit is cleared, at least one code word is completed when the HCS101 is activated. If this bit is set, at least four complete code words are transmitted.

4.3.5 TRANSMIT PULSE ENABLE (TXEN)

If this bit is cleared, no start pulse occurs before a transmission. If the bit is set, a start pulse (1 TE long) is transmitted before the first code word's preamble.

4.3.6 S3 SETTING (S3SET)

This bit determines the value of S3 in the function code during a transmission and the high trip point selected by V_{LOWS} in Section 4.3.2. If this bit is cleared, S3 mirrors S2 during a transmission. If the S3SET bit is set, S3 in the function code is always set, independent of the value of S2.

4.3.7 EXTENDED SERIAL NUMBER (XSER)

If this bit is cleared, the most significant four bits of the 32-bit Serial Number 1 are replaced with the function code. If this bit is set, the full 32-bit Serial Number 1 is transmitted.

5.0 SPECIAL FEATURES

5.1 Code Word Completion

Code word completion is an automatic feature that ensures the entire code word is transmitted, even if the button is released before the transmission is complete. If the button is held down beyond the time for one code word, multiple code words will result. If another button is activated during a transmission, the active transmission will be aborted and a new transmission will begin using the new button information.

5.2 Blank Alternate Code Word

Federal Communications Commission (FCC) Rules, Part 15 specify the limits on fundamental power and harmonics that can be transmitted. Power is calculated on the worst case average power transmitted in a 100 ms window. It is therefore advantageous to minimize the duty cycle of the transmission by minimizing the duty cycle of the individual bits and by blanking out consecutive words. The transmission duty cycle can be lowered by setting BRS. This reduces the average power transmitted and hence, assists in FCC approval of a transmitter device. Shortening the code word length and transmitting only every other code word (Figure 5-1) also may allow a higher amplitude transmission for greater range.

5.3 Auto-Shutoff

The auto-shutoff function automatically stops the device from transmitting if a button inadvertently gets pressed for longer than the time-out period, T_{TO}. This will prevent the device from draining the battery if a button gets pressed while the transmitter is in a pocket or purse.

5.4 V_{LOW}: Voltage LOW Indicator

The V_{LOW} bit is included in every transmission and will be transmitted as a one if the operating voltage has dropped below the low voltage trip point. Refer to Figure 3-2. The trip point is selectable based on the battery voltage being used. See Section 4.3.2 for a description of how the low voltage select option is set.

FIGURE 5-1: CODE WORD TRANSMISSIONS

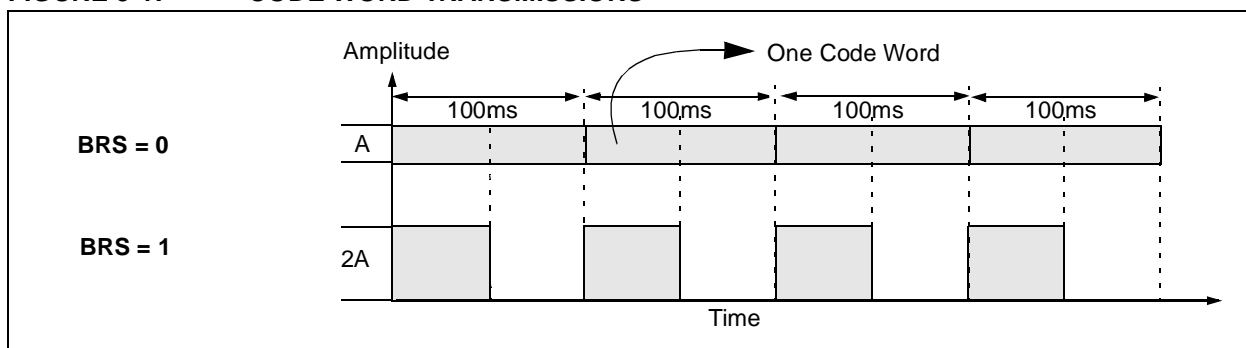

6.0 PROGRAMMING THE HCS101

When using the HCS101 in a system, the user will have to program some parameters into the device, including the serial number and the counter, before it can be used. The programming cycle allows the user to input a 192-bit serial data stream which is then stored internally in EEPROM. Programming will be initiated by forcing the DATA line high after the S2 line has been held high for the appropriate length of time. Refer to Table 6-1 and Figure 6-1.

After the Program mode is entered, a delay must be provided to the device for the automatic bulk write cycle to complete. This will write all locations in the EEPROM to all zeros. The device can then be programmed by clocking in 16 bits at a time, using S2 as the clock line and DATA as the data in line. After each 16-bit word is loaded, a programming delay is required for the internal program cycle to complete. This delay can take up to T_{wc} .

The HCS101 will signal that the write is complete by sending out a train of ACK pulses, TACKH high, TACKL low on DATA. The ACK pulses will continue until S2 is dropped. These times can be used to calculate the oscillator calibration value. The first pulse's width should NOT be used for calibration.

At the end of the programming cycle, the device can be verified as shown in Figure 6-2 by reading back the EEPROM. Reading is done by clocking the S2 line and reading the data bits on the DATA pin. **A verify operation can only be done once, immediately following the program cycle.**

Note: To ensure that the device does not accidentally enter Programming mode, DATA should never be pulled high by the circuit connected to it. Special care should be taken when driving PNP RF transistors.

FIGURE 6-1: PROGRAMMING WAVEFORMS

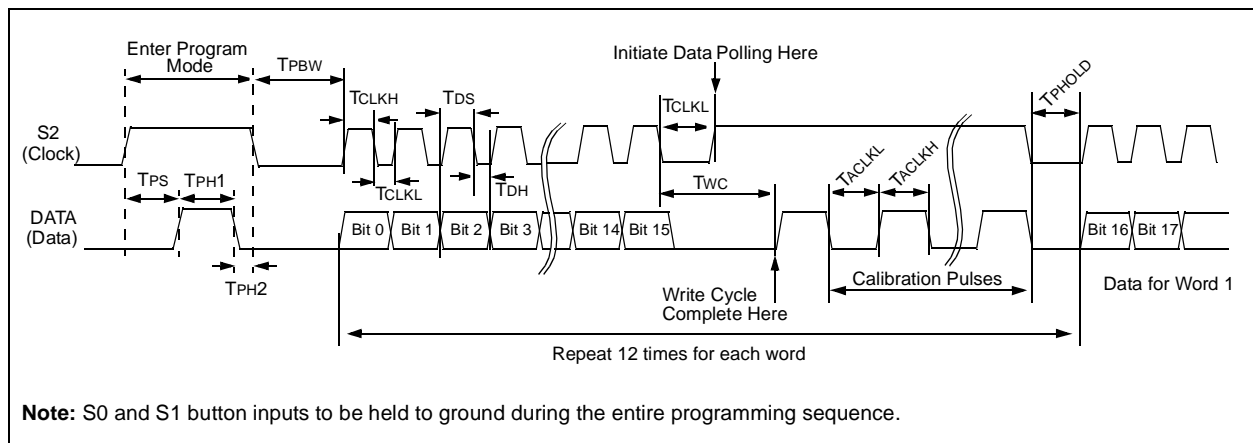
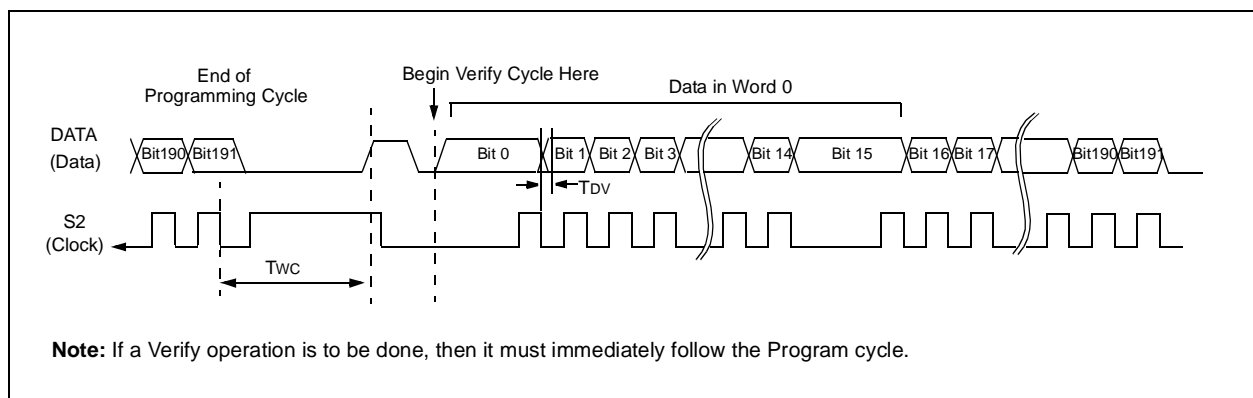

FIGURE 6-2: VERIFY WAVEFORMS



HCS101

[查询HCS101供应商](#)

TABLE 6-1: PROGRAMMING/VERIFY TIMING REQUIREMENTS

VDD = 5.0V ± 10% 25° C ± 5°C				
Parameter	Symbol	Min.	Max.	Units
Program mode setup time	TPS	2.0	5.0	ms
Hold time 1	TPH1	4.0	—	ms
Hold time 2	TPH2	50	—	µs
Bulk Write time	TPBW	4.0	—	ms
Program delay time	TPROG	4.0	—	ms
Program cycle time	TWC	50	—	ms
Clock low time	TCLKL	50	—	µs
Clock high time	TCLKH	50	—	µs
Data setup time	TDS	0	—	µs
Data hold time	TDH	30	—	µs
Data out valid time	TDV	—	30	µs
Hold time	TPHOLD	100	—	µs ⁽¹⁾
Acknowledge low time	TACKL	800	—	µs ⁽¹⁾
Acknowledge high time	TACKH	800	—	µs ⁽¹⁾

Note 1: Typical values - not tested in production

7.0 ELECTRICAL CHARACTERISTICS FOR HCS101

Absolute Maximum Ratings[†]

VDD Supply voltage	-0.3 to 13.5 V
VIN Input voltage	-0.3 to VDD + 0.3 V
VOUT Output voltage	-0.3 to VDD + 0.3 V
IOUT Max output current.....	50 mA
TSTG Storage temperature (Note)	-55 to +125°C
TL501 Lead soldering temp (Note).....	300°C
VESD ESD rating	2000 V

[†] **NOTICE:** Stresses above those listed under “Absolute Maximum Ratings” may cause permanent damage to the device. This is a stress rating only and functional operation of the device at those or any other conditions above those indicated in the operation listings of this specification is not implied. Exposure to maximum rating conditions for extended periods may affect device reliability.

TABLE 7-1: DC CHARACTERISTICS

Commercial (C):TAMB = 0°C to +70°C Industrial (I):TAMB = -40°C to +85°C									
		3.5V < VDD < 5.0V			5.0V < VDD < 13.3V				
Parameter	Sym.	Min.	Typ ¹	Max.	Min.	Typ ¹	Max.	Unit	Conditions
Operating Current (avg) ⁽²⁾	ICC		—	0.5		—	2	mA	
Standby Current	ICCS		0.1	1.0		0.1	1.0	µA	
Auto-shutoff Current ^(3,4)	ICCS		40	75		160	300	µA	
High Level Input Voltage	VIH	0.55VDD		VDD+0.3	2.75		VDD+0.3	V	
Low Level Input Voltage	VIL	-0.3		0.15VDD	-0.3		0.75	V	
High Level Output Voltage	VOH	0.6VDD			3.3			V	IOH = -1.0 mA VDD = 3.5V IOH = -2.0 mA VDD = 10V
Low Level Output Voltage	VOL			0.08VDD			0.4	V	IOL = 1.0 mA VDD = 3.5V IOL = 2.0 mA VDD = 10V
Pull-down Resistance; S0-S2	RSO-2	40	60	80	40	60	80	kΩ	VDD = 4.0V
Pull-down Resistance; DATA	RDATA	80	120	160	80	120	160	kΩ	VDD = 4.0V

- Note 1:** Typical values are at 25°C.
Note 2: No load.
Note 3: Auto-shutoff current specification does not include the current through the input pulldown resistors.
Note 4: Auto-shutoff current is periodically sampled and not 100% tested.

HCS101

[查询HCS101供应商](#)

FIGURE 7-1: POWER-UP AND TRANSMIT TIMING

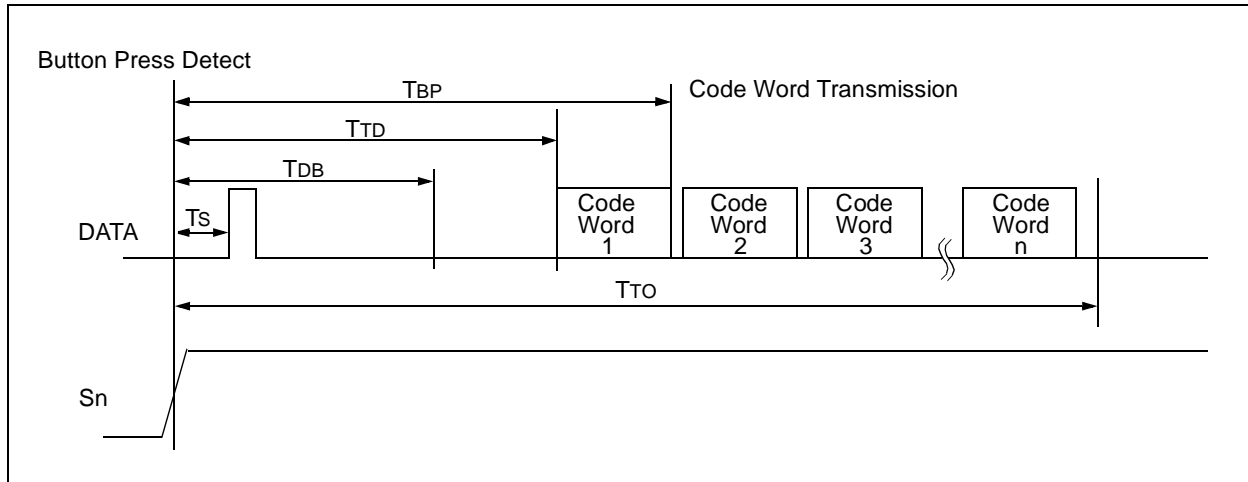

TABLE 7-2: POWER-UP AND TRANSMIT TIMING⁽²⁾

		Standard Operating Conditions (unless otherwise specified): Commercial (C): $0^{\circ}\text{C} \leq T_A \leq +70^{\circ}\text{C}$ Industrial (I): $-40^{\circ}\text{C} \leq T_A \leq +85^{\circ}\text{C}$				
Symbol	Parameters	Min.	Typ.	Max.	Units	Conditions
TBP	Time to second button press	10 + Code Word Time	—	26 + Code Word Time	ms	(Note 1)
TTD	Transmit delay from button detect	12	—	26	ms	
TDB	Debounce delay	6	—	20	ms	
TTO	Auto-shutoff time-out period	—	27	—	s	
Ts	Start pulse delay	—	4.5	—	ms	

Note 1: TBP is the time in which a second button can be pressed without completion of the first code word and the intention was to press the combination of buttons.

2: Typical values - not tested in production.

FIGURE 7-2: PREAMBLE/HEADER FORMAT

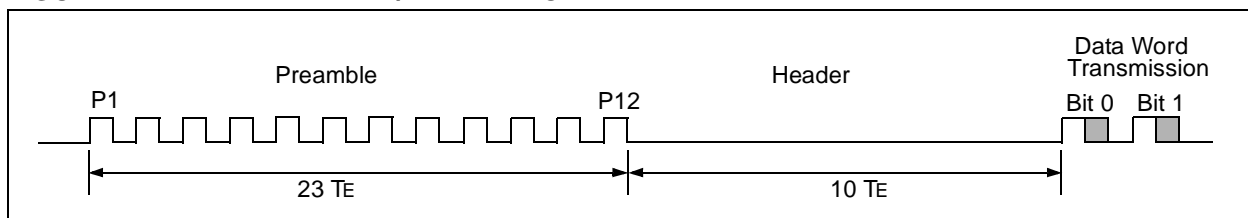

FIGURE 7-3: DATA WORD FORMAT (XSER = 0)

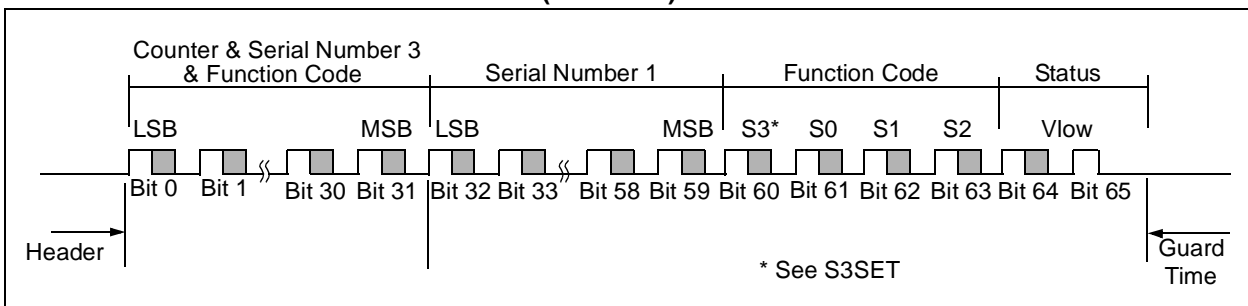

TABLE 7-3: CODE WORD TRANSMISSION TIMING REQUIREMENTS

VDD = +3.5 to 13.3V Commercial (C):TAMB = 0°C to +70°C Industrial (I):TAMB = -40°C to +85°C			Code Words Transmitted						Units
			All			1 out of 2			
Symbol	Characteristic	Number of TE	Min.	Typ.	Max.	Min.	Typ.	Max.	Units
TE	Basic pulse element	1	360	400	440	180	200	220	μs
TBP	PWM bit pulse width	3	—	3	—	—	3	—	ms
TP	Preamble duration	24	8.64	9.6	10.56	4.32	4.8	5.28	ms
TH	Header duration	10	3.6	4.0	4.4	1.8	2.0	2.2	ms
THOP	Hopping code duration	96	34.56	38.4	42.24	17.28	19.2	21.12	ms
TFIX	Fixed code duration	102	36.72	40.8	44.88	18.36	20.4	22.44	ms
TG	Guard Time	39	14.04	15.6	17.16	7.02	7.8	8.58	ms
—	Total Transmit Time	271	97.56	108.4	119.24	48.78	54.2	59.62	ms
—	PWM data rate	—	925	833	757	1851	1667	1515	bps

Note: The timing parameters are not tested but derived from the oscillator clock.

HCS101

[查询HCS101供应商](#)

8.0 PACKAGING INFORMATION

8.1 Package Marking Information

8-Lead PDIP (300 mil)

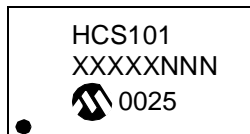

8-Lead SOIC (150 mil)



Legend:	XX...X	Customer specific information*
	Y	Year code (last digit of calendar year)
	YY	Year code (last 2 digits of calendar year)
	WW	Week code (week of January 1 is week '01')
	NNN	Alphanumeric traceability code
Note: In the event the full Microchip part number cannot be marked on one line, it will be carried over to the next line thus limiting the number of available characters for customer specific information.		

* Standard PICmicro device marking consists of Microchip part number, year code, week code, and traceability code. For PICmicro device marking beyond this, certain price adders apply. Please check with your Microchip Sales Office. For QTP devices, any special marking adders are included in QTP price.

8.2 Package Details

8-Lead Plastic Dual In-line (P) - 300 mil (PDIP)

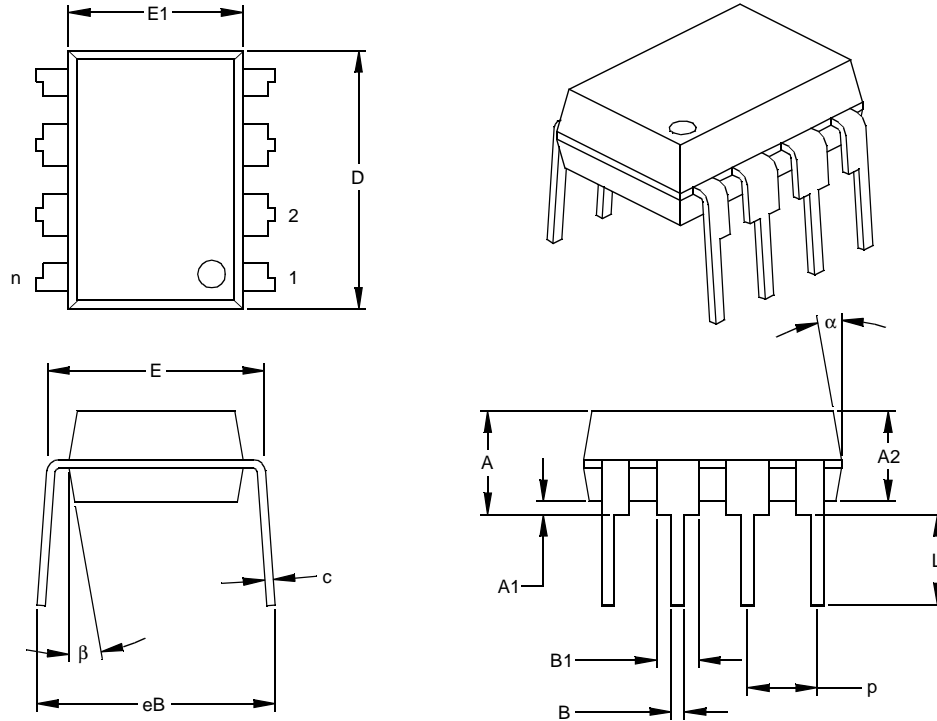

Units		INCHES*			MILLIMETERS		
Dimension Limits		MIN	NOM	MAX	MIN	NOM	MAX
Number of Pins	n		8			8	
Pitch	p		.100			2.54	
Top to Seating Plane	A	.140	.155	.170	3.56	3.94	4.32
Molded Package Thickness	A2	.115	.130	.145	2.92	3.30	3.68
Base to Seating Plane	A1	.015			0.38		
Shoulder to Shoulder Width	E	.300	.313	.325	7.62	7.94	8.26
Molded Package Width	E1	.240	.250	.260	6.10	6.35	6.60
Overall Length	D	.360	.373	.385	9.14	9.46	9.78
Tip to Seating Plane	L	.125	.130	.135	3.18	3.30	3.43
Lead Thickness	c	.008	.012	.015	0.20	0.29	0.38
Upper Lead Width	B1	.045	.058	.070	1.14	1.46	1.78
Lower Lead Width	B	.014	.018	.022	0.36	0.46	0.56
Overall Row Spacing	§ eB	.310	.370	.430	7.87	9.40	10.92
Mold Draft Angle Top	α	5	10	15	5	10	15
Mold Draft Angle Bottom	β	5	10	15	5	10	15

* Controlling Parameter

§ Significant Characteristic

Notes:

Dimensions D and E1 do not include mold flash or protrusions. Mold flash or protrusions shall not exceed .010" (0.254mm) per side.

JEDEC Equivalent: MS-001

Drawing No. C04-018

HCS101

[查询HCS101供应商](#)

8-Lead Plastic Small Outline (SN) - Narrow, 150 mil (SOIC)

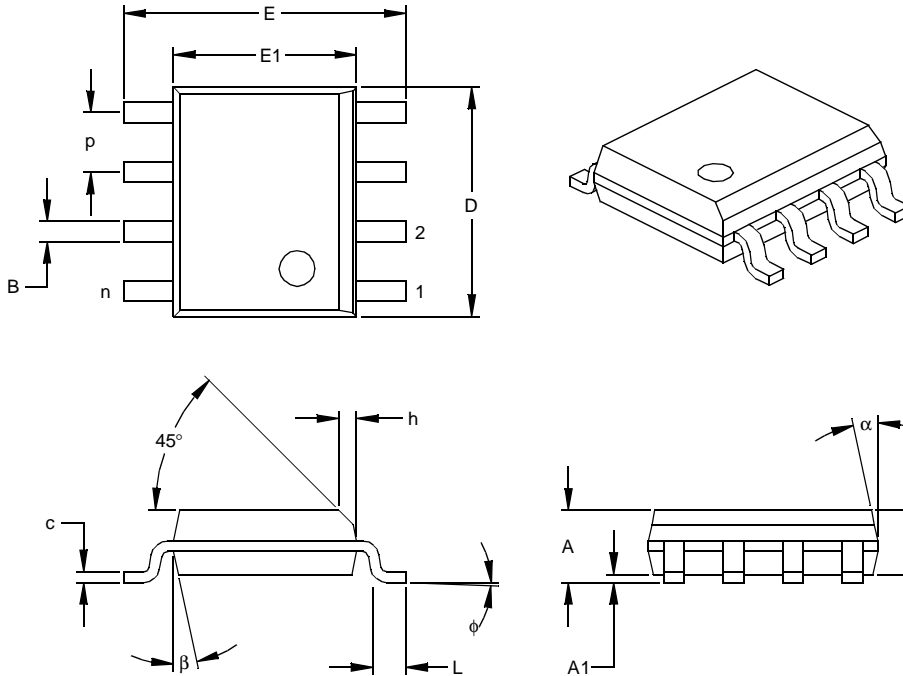

Dimension Limits	Units	INCHES*			MILLIMETERS		
		MIN	NOM	MAX	MIN	NOM	MAX
Number of Pins	n		8			8	
Pitch	p		.050			1.27	
Overall Height	A	.053	.061	.069	1.35	1.55	1.75
Molded Package Thickness	A2	.052	.056	.061	1.32	1.42	1.55
Standoff §	A1	.004	.007	.010	0.10	0.18	0.25
Overall Width	E	.228	.237	.244	5.79	6.02	6.20
Molded Package Width	E1	.146	.154	.157	3.71	3.91	3.99
Overall Length	D	.189	.193	.197	4.80	4.90	5.00
Chamfer Distance	h	.010	.015	.020	0.25	0.38	0.51
Foot Length	L	.019	.025	.030	0.48	0.62	0.76
Foot Angle	φ	0	4	8	0	4	8
Lead Thickness	c	.008	.009	.010	0.20	0.23	0.25
Lead Width	B	.013	.017	.020	0.33	0.42	0.51
Mold Draft Angle Top	α	0	12	15	0	12	15
Mold Draft Angle Bottom	β	0	12	15	0	12	15

* Controlling Parameter

§ Significant Characteristic

Notes:

Dimensions D and E1 do not include mold flash or protrusions. Mold flash or protrusions shall not exceed .010" (0.254mm) per side.

JEDEC Equivalent: MS-012

Drawing No. C04-057

ON-LINE SUPPORT

Microchip provides on-line support on the Microchip World Wide Web (WWW) site.

The web site is used by Microchip as a means to make files and information easily available to customers. To view the site, the user must have access to the Internet and a web browser, such as Netscape or Microsoft Explorer. Files are also available for FTP download from our FTP site.

Connecting to the Microchip Internet Web Site

The Microchip web site is available by using your favorite Internet browser to attach to:

www.microchip.com

The file transfer site is available by using an FTP service to connect to:

<ftp://ftp.microchip.com>

The web site and file transfer site provide a variety of services. Users may download files for the latest Development Tools, Data Sheets, Application Notes, User's Guides, Articles and Sample Programs. A variety of Microchip specific business information is also available, including listings of Microchip sales offices, distributors and factory representatives. Other data available for consideration is:

- Latest Microchip Press Releases
- Technical Support Section with Frequently Asked Questions
- Design Tips
- Device Errata
- Job Postings
- Microchip Consultant Program Member Listing
- Links to other useful web sites related to Microchip Products
- Conferences for products, Development Systems, technical information and more
- Listing of seminars and events

Systems Information and Upgrade Hot Line

The Systems Information and Upgrade Line provides system users a listing of the latest versions of all of Microchip's development systems software products. Plus, this line provides information on how customers can receive any currently available upgrade kits. The Hot Line Numbers are:

1-800-755-2345 for U.S. and most of Canada, and

1-480-792-7302 for the rest of the world.

HCS101

[查询HCS101供应商](#)

READER RESPONSE

It is our intention to provide you with the best documentation possible to ensure successful use of your Microchip product. If you wish to provide your comments on organization, clarity, subject matter, and ways in which our documentation can better serve you, please FAX your comments to the Technical Publications Manager at (480) 792-4150.

Please list the following information, and use this outline to provide us with your comments about this Data Sheet.

To: Technical Publications Manager Total Pages Sent
RE: Reader Response
From: Name _____
Company _____
Address _____
City / State / ZIP / Country _____
Telephone: (_____) _____ - _____ FAX: (_____) _____ - _____

Application (optional):

Would you like a reply? ___Y ___N

Device: **HCS101**

Literature Number: **DS41115C**

Questions:

1. What are the best features of this document?

2. How does this document meet your hardware and software development needs?

3. Do you find the organization of this data sheet easy to follow? If not, why?

4. What additions to the data sheet do you think would enhance the structure and subject?

5. What deletions from the data sheet could be made without affecting the overall usefulness?

6. Is there any incorrect or misleading information (what and where)?

7. How would you improve this document?

8. How would you improve our software, systems, and silicon products?

[查询HCS101供应商](#)

HCS101 PRODUCT IDENTIFICATION SYSTEM

To order or obtain information, e.g., on pricing or delivery, refer to the factory or the listed sales office.

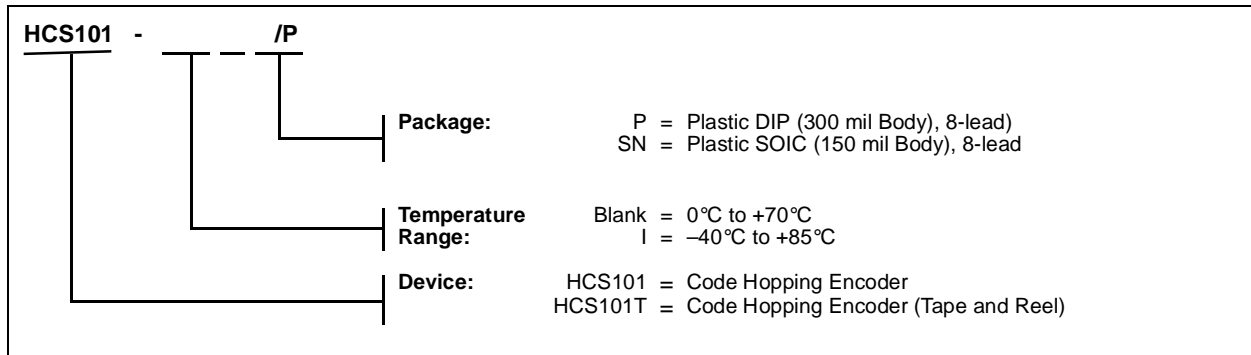

Sales and Support

Data Sheets

Products supported by a preliminary Data Sheet may have an errata sheet describing minor operational differences and recommended workarounds. To determine if an errata sheet exists for a particular device, please contact one of the following:

1. Your local Microchip sales office.
2. The Microchip Corporate Literature Center U.S. FAX: (480) 792-7277.
3. The Microchip Worldwide Site. (www.microchip.com)

Please specify which device, revision of silicon and Data Sheet (include Literature #) you are using.

New Customer Notification System

Register on our web site (www.microchip.com/cn) to receive the most current information on our products.

HCS101

[查询HCS101供应商](#)

NOTES:

Note the following details of the code protection feature on PICmicro® MCUs.

- The PICmicro family meets the specifications contained in the Microchip Data Sheet.
- Microchip believes that its family of PICmicro microcontrollers is one of the most secure products of its kind on the market today, when used in the intended manner and under normal conditions.
- There are dishonest and possibly illegal methods used to breach the code protection feature. All of these methods, to our knowledge, require using the PICmicro microcontroller in a manner outside the operating specifications contained in the data sheet. The person doing so may be engaged in theft of intellectual property.
- Microchip is willing to work with the customer who is concerned about the integrity of their code.
- Neither Microchip nor any other semiconductor manufacturer can guarantee the security of their code. Code protection does not mean that we are guaranteeing the product as “unbreakable”.
- Code protection is constantly evolving. We at Microchip are committed to continuously improving the code protection features of our product.

If you have any further questions about this matter, please contact the local sales office nearest to you.

Information contained in this publication regarding device applications and the like is intended through suggestion only and may be superseded by updates. It is your responsibility to ensure that your application meets with your specifications. No representation or warranty is given and no liability is assumed by Microchip Technology Incorporated with respect to the accuracy or use of such information, or infringement of patents or other intellectual property rights arising from such use or otherwise. Use of Microchip's products as critical components in life support systems is not authorized except with express written approval by Microchip. No licenses are conveyed, implicitly or otherwise, under any intellectual property rights.

Trademarks

The Microchip name and logo, the Microchip logo, PIC, PICmicro, PICMASTER, PICSTART, PRO MATE, KEELoQ, SEEVAL, MPLAB and The Embedded Control Solutions Company are registered trademarks of Microchip Technology Incorporated in the U.S.A. and other countries.

Total Endurance, ICSP, In-Circuit Serial Programming, FilterLab, MXDEV, microID, FlexROM, fuzzyLAB, MPASM, MPLINK, MPLIB, PICC, PICDEM, PICDEM.net, ICEPIC, Migratable Memory, FanSense, ECONOMONITOR, Select Mode, dsPIC, rPIC and microPort are trademarks of Microchip Technology Incorporated in the U.S.A.

Serialized Quick Term Programming (SQTP) is a service mark of Microchip Technology Incorporated in the U.S.A.

All other trademarks mentioned herein are property of their respective companies.

© 2001, Microchip Technology Incorporated, Printed in the U.S.A., All Rights Reserved.

 Printed on recycled paper.

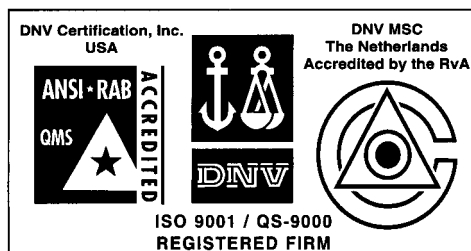

Microchip received QS-9000 quality system certification for its worldwide headquarters, design and wafer fabrication facilities in Chandler and Tempe, Arizona in July 1999. The Company's quality system processes and procedures are QS-9000 compliant for its PICmicro® 8-bit MCUs, KEELoQ® code hopping devices, Serial EEPROMs and microperipheral products. In addition, Microchip's quality system for the design and manufacture of development systems is ISO 9001 certified.

WORLDWIDE SALES AND SERVICE

AMERICAS

Corporate Office

2355 West Chandler Blvd.
Chandler, AZ 85224-6199
Tel: 480-792-7200 Fax: 480-792-7277
Technical Support: 480-792-7627
Web Address: <http://www.microchip.com>

Rocky Mountain

2355 West Chandler Blvd.
Chandler, AZ 85224-6199
Tel: 480-792-7966 Fax: 480-792-7456

Atlanta

500 Sugar Mill Road, Suite 200B
Atlanta, GA 30350
Tel: 770-640-0034 Fax: 770-640-0307

Austin - Analog

13740 North Highway 183
Building J, Suite 4
Austin, TX 78750
Tel: 512-257-3370 Fax: 512-257-8526

Boston

2 Lan Drive, Suite 120
Westford, MA 01886
Tel: 978-692-3848 Fax: 978-692-3821

Boston - Analog

Unit A-8-1 Millbrook Tarry Condominium
97 Lowell Road
Concord, MA 01742
Tel: 978-371-6400 Fax: 978-371-0050

Chicago

333 Pierce Road, Suite 180
Itasca, IL 60143
Tel: 630-285-0071 Fax: 630-285-0075

Dallas

4570 Westgrove Drive, Suite 160
Addison, TX 75001
Tel: 972-818-7423 Fax: 972-818-2924

Dayton

Two Prestige Place, Suite 130
Miamisburg, OH 45342
Tel: 937-291-1654 Fax: 937-291-9175

Detroit

Tri-Atria Office Building
32255 Northwestern Highway, Suite 190
Farmington Hills, MI 48334
Tel: 248-538-2250 Fax: 248-538-2260

Los Angeles

18201 Von Karman, Suite 1090
Irvine, CA 92612
Tel: 949-263-1888 Fax: 949-263-1338

New York

150 Motor Parkway, Suite 202
Hauppauge, NY 11788
Tel: 631-273-5305 Fax: 631-273-5335

San Jose

Microchip Technology Inc.
2107 North First Street, Suite 590
San Jose, CA 95131
Tel: 408-436-7950 Fax: 408-436-7955

Toronto

6285 Northam Drive, Suite 108
Mississauga, Ontario L4V 1X5, Canada
Tel: 905-673-0699 Fax: 905-673-6509

ASIA/PACIFIC

Australia

Microchip Technology Australia Pty Ltd
Suite 22, 41 Rawson Street
Epping 2121, NSW
Australia
Tel: 61-2-9868-6733 Fax: 61-2-9868-6755

China - Beijing

Microchip Technology Consulting (Shanghai)
Co., Ltd., Beijing Liaison Office
Unit 915
Bei Hai Wan Tai Bldg.
No. 6 Chaoyangmen Beidajie
Beijing, 100027, No. China
Tel: 86-10-85282100 Fax: 86-10-85282104

China - Chengdu

Microchip Technology Consulting (Shanghai)
Co., Ltd., Chengdu Liaison Office
Rm. 2401, 24th Floor,
Ming Xing Financial Tower
No. 88 TIDU Street
Chengdu 610016, China
Tel: 86-28-6766200 Fax: 86-28-6766599

China - Fuzhou

Microchip Technology Consulting (Shanghai)
Co., Ltd., Fuzhou Liaison Office
Rm. 531, North Building
Fujian Foreign Trade Center Hotel
73 Wusi Road
Fuzhou 350001, China
Tel: 86-591-7557563 Fax: 86-591-7557572

China - Shanghai

Microchip Technology Consulting (Shanghai)
Co., Ltd.
Room 701, Bldg. B
Far East International Plaza
No. 317 Xian Xia Road
Shanghai, 200051
Tel: 86-21-6275-5700 Fax: 86-21-6275-5060

China - Shenzhen

Microchip Technology Consulting (Shanghai)
Co., Ltd., Shenzhen Liaison Office
Rm. 1315, 13/F, Shenzhen Kerry Centre,
Renminnan Lu
Shenzhen 518001, China
Tel: 86-755-2350361 Fax: 86-755-2366086

Hong Kong

Microchip Technology Hongkong Ltd.
Unit 901-6, Tower 2, Metroplaza
223 Hing Fong Road
Kwai Fong, N.T., Hong Kong
Tel: 852-2401-1200 Fax: 852-2401-3431

India

Microchip Technology Inc.
India Liaison Office
Divyasree Chambers
1 Floor, Wing A (A3/A4)
No. 11, O'Shaughnessey Road
Bangalore, 560 025, India
Tel: 91-80-2290061 Fax: 91-80-2290062

Japan

Microchip Technology Japan K.K.
Benex S-1 6F
3-18-20, Shinyokohama
Kohoku-Ku, Yokohama-shi
Kanagawa, 222-0033, Japan
Tel: 81-45-471-6166 Fax: 81-45-471-6122

Korea

Microchip Technology Korea
168-1, Youngbo Bldg. 3 Floor
Samsung-Dong, Kangnam-Ku
Seoul, Korea 135-882
Tel: 82-2-554-7200 Fax: 82-2-558-5934

Singapore

Microchip Technology Singapore Pte Ltd.
200 Middle Road
#07-02 Prime Centre
Singapore, 188980
Tel: 65-334-8870 Fax: 65-334-8850

Taiwan

Microchip Technology Taiwan
11F-3, No. 207
Tung Hua North Road
Taipei, 105, Taiwan
Tel: 886-2-2717-7175 Fax: 886-2-2545-0139

EUROPE

Denmark

Microchip Technology Denmark ApS
Regus Business Centre
Lautrup høj 1-3
Ballerup DK-2750 Denmark
Tel: 45 4420 9895 Fax: 45 4420 9910

France

Arizona Microchip Technology SARL
Parc d'Activite du Moulin de Massy
43 Rue du Saule Trapu
Batiment A - 1er Etage
91300 Massy, France
Tel: 33-1-69-53-63-20 Fax: 33-1-69-30-90-79

Germany

Arizona Microchip Technology GmbH
Gustav-Heinemann Ring 125
D-81739 Munich, Germany
Tel: 49-89-627-144 0 Fax: 49-89-627-144-44

Germany - Analog

Lochamer Strasse 13
D-82152 Martinsried, Germany
Tel: 49-89-895650-0 Fax: 49-89-895650-22

Italy

Arizona Microchip Technology SRL
Centro Direzionale Colleoni
Palazzo Taurus 1 V. Le Colleoni 1
20041 Agrate Brianza
Milan, Italy
Tel: 39-039-65791-1 Fax: 39-039-6899883

United Kingdom

Arizona Microchip Technology Ltd.
505 Eskdale Road
Winnersh Triangle
Wokingham
Berkshire, England RG41 5TU
Tel: 44 118 921 5869 Fax: 44-118 921-5820