

# 32K x 36 Bit Synchronous Dual I/O, Dual Address SRAM

**MCM69D536**

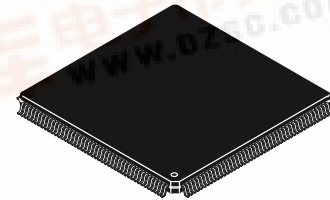

**TQ PACKAGE**  
176 LEAD TQFP  
CASE 1101-01

The MCM69D536 is a 1M-bit static random access memory, organized as 32K words of 36 bits. It features common data input and data output buffers and incorporates input and output registers on-board with high speed SRAM.

The MCM69D536 allows the user to concurrently perform reads, writes, or pass-through cycles in combination on the two data ports. The two address ports (AX, AY) determine the read or write locations for their respective data ports (DQX, DQY).

The synchronous design allows for precise cycle control with the use of an external single clock (K). All signal pins except output enables (GX, GY) are registered on the rising edge of clock (K).

The pass-through feature allows data to be passed from one port to the other, in either direction. The PTX input must be asserted to pass data from port X to port Y. The PTY will likewise pass data from port Y to port X. A pass-through operation takes precedence over a read operation.

For the case when AX and AY are the same, certain protocols are followed. If both ports are read, the reads occur normally. If one port is written and the other is read, the read from the array will occur before the data is written. If both ports are written, only the data on DQY will be written to the array.

- Single 3.3 V ± 5% Power Supply
- Fast Access Times: 6/8 ns Max
- Throughput of 2.98 Gigabits/Second
- Single Clock Operation
- Address, Data Input, E1, E2, PTX, PTY, WX, WY, and Data Output Registers On-Chip
- 83 MHz Maximum Clock Frequency
- Self-Timed Write
- Two Bi-Directional Data Buses
- Can be Configured as Separate I/O
- Pass-Through Feature
- Asynchronous Output Enables (GX, GY)
- LVTTL Compatible I/O
- Concurrent Reads and Writes
- 176-Pin TQFP Package

### Suggested Applications

- ATM
- Ethernet Switches
- Routers
- Cell/Frame Buffers
- SNA Switches
- Shared Memory

### Product Family Configurations

Part Number	Dual Address	Single Address	Dual I/O	Separate I/O	Configuration	V <sub>DD</sub>
MCM69D536	✓	Note 1	✓	Note 2	32K x 36	3.3 V
MCM69D618	✓	Note 1	✓	Note 2	64K x 18	3.3 V
MCM67Q709A		✓		✓	128K x 9	5.0 V
MCM67Q909		✓		✓	512K x 9	5.0 V

### NOTES:

1. Tie AX and AY address ports together for the part to function as a single address part.
2. Tie GX high for DQX to be inputs and tie WY high and GY low for DQY to be outputs.

**BLOCK DIAGRAM**

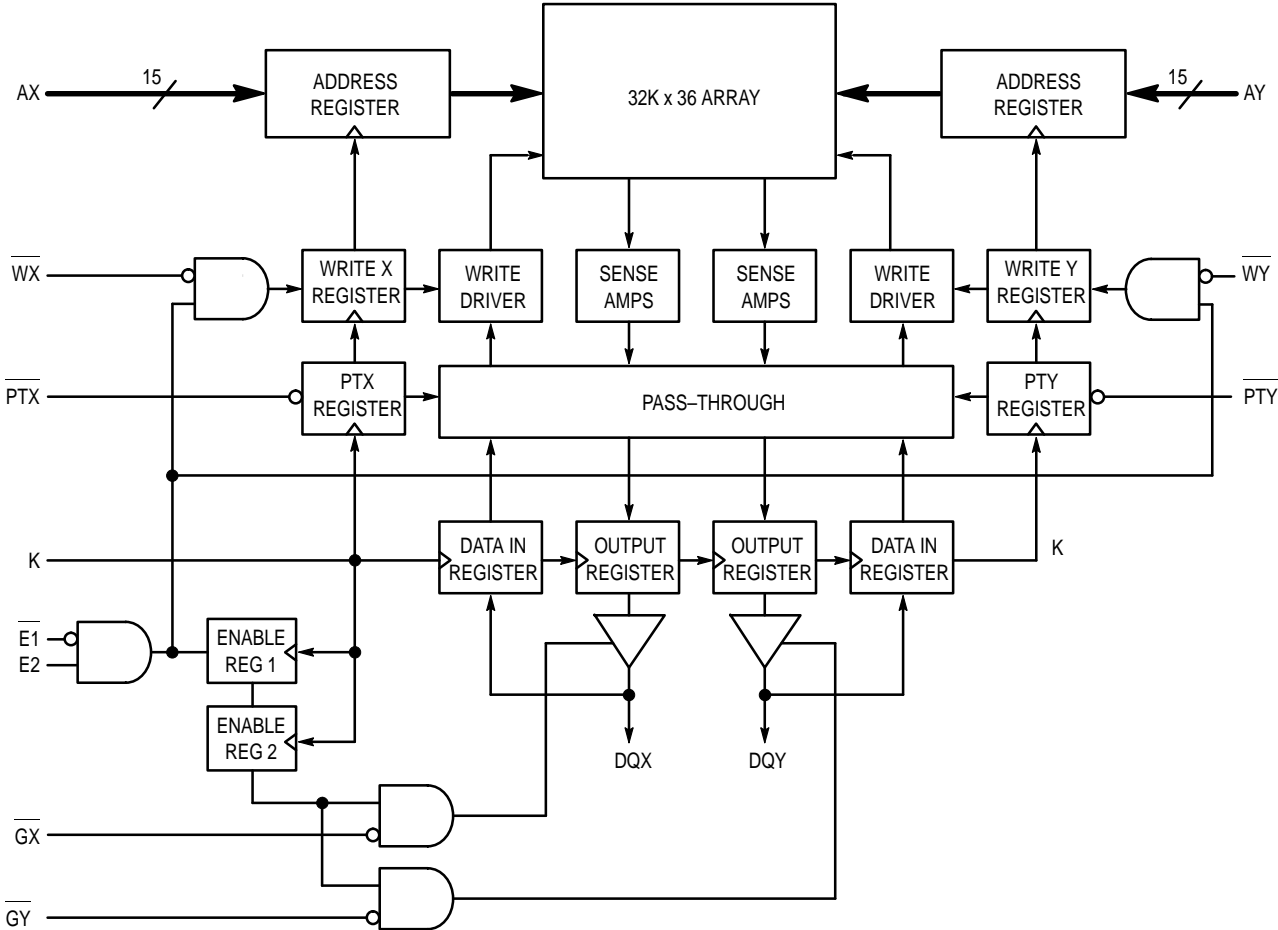



## PIN DESCRIPTIONS

Pin Locations	Symbol	Type	Description
65, 63, 61, 59, 57, 55, 169, 167, 145, 143, 68, 70, 72, 74, 76	AX0 – AX14	Input	Address Port X. Never allow floating addresses for inputs AX0 – AX14. A pullup resistor is needed.
64, 62, 60, 58, 56, 54, 168, 166, 144, 142, 69, 71, 73, 75, 77	AY0 – AY14	Input	Address Port Y. Never allow floating addresses for inputs AY0 – AY14. A pullup resistor is needed.
82, 86, 90, 94, 96, 100, 102, 106, 108, 113, 115, 119, 121, 125, 127, 131, 135, 139, 170, 174, 2, 6, 8, 12, 14, 18, 20, 25, 27, 31, 33, 37, 39, 43, 47, 51	DQX0 – DQX35	I/O	Data Input/Output Port X.
83, 87, 91, 95, 97, 101, 103, 107, 109, 112, 114, 118, 120, 124, 126, 130, 134, 138, 171, 175, 3, 7, 9, 13, 15, 19, 21, 24, 26, 30, 32, 36, 38, 42, 46, 50	DQY0 – DQY35	I/O	Data Input/Output Port Y.
150	E1	Input	Synchronous Chip Enable: Active low.
151	E2	Input	Synchronous Chip Enable: Active high.
152	GX	Input	Asynchronous Output Enable Port X Input: Low — enables output buffers (DQXx pins). High — DQXx pins are high impedance.
153	GY	Input	Asynchronous Output Enable Port Y Input: Low — enables output buffers (DQYx pins). High — DQYx pins are high impedance.
156	K	Input	Clock: This signal registers the address, data in, and all control signals except G.
146	PTX	Input	Pass-Through Port X.
147	PTY	Input	Pass-Through Port Y.
148	WX	Input	Synchronous Write Enable Port X.
149	WY	Input	Synchronous Write Enable Port Y.
4, 10, 16, 22, 28, 34, 40, 49, 67, 84, 92, 98, 104, 110, 116, 122, 128, 137, 155, 172	V <sub>DD</sub>	Supply	+ 3.3 V Power Supply.
5, 11, 17, 23, 29, 35, 41, 48, 66, 85, 93, 99, 105, 111, 117, 123, 129, 136, 154, 173	V <sub>SS</sub>	Supply	Ground.
1, 44, 45, 52, 53, 88, 89, 132, 133, 165, 176	V <sub>SSi</sub>	Input	Bonded to die flag. No chip current flows through these pins.
78– 81, 140, 141, 157 – 164	NC	—	No Connection: There is no connection to the chip.

**TRUTH TABLE** (See Notes 1 through 5)

Operation Number	Input at $t_n$ Clock						Operation
	E1	E2	WX	WY	PTX	PTY	
1	H	X	X	X	X	X	Deselected
2	X	L	X	X	X	X	Deselected
3	L	H	0	X	X	X	Write X Port
4	L	H	X	0	X	X	Write Y Port
5	L	H	X	X	0	X	Pass-Through X to Y
6	L	H	X	X	X	0	Pass-Through Y to X
7	L	H	1	X	1	1	Read X
8	L	H	X	1	1	1	Read Y

**NOTES:** \_\_\_\_

1. GX/GY must be controlled to avoid bus contention issues during write and pass-through cycles.
2. Operation numbers 3 – 6 can be used in any combination.
3. Operation numbers 4 and 7, 3 and 8, 7 and 8 can be combined.
4. Operation number 5 can not be combined with operation number 7 or 8 because pass-through takes precedence over a read operation.
5. Operation number 6 can not be combined with operation number 7 or 8 because pass-through takes precedence over a read operation.

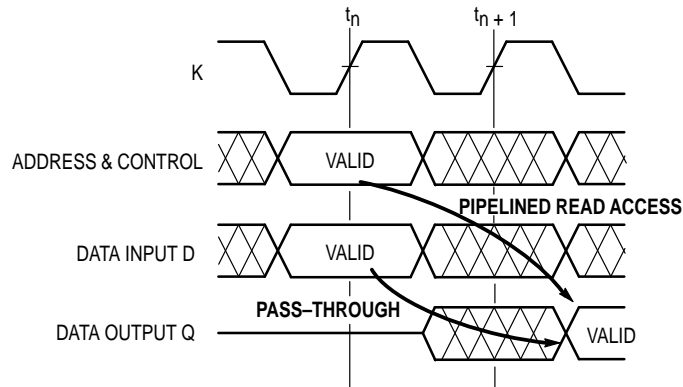

**ABSOLUTE MAXIMUM RATINGS** (See Note)

Rating	Symbol	Value	Unit
Power Supply Voltage	$V_{DD}$	- 0.5 to + 4.6	V
Voltage Relative to $V_{SS}$ for Any Pin Except $V_{DD}$	$V_{in}, V_{out}$	- 0.5 to $V_{DD} + 0.5$	V
Output Current	$I_{out}$	$\pm 20$	mA
Power Dissipation	$P_D$	TBD	W
Temperature Under Bias	$T_{bias}$	- 10 to + 85	$^{\circ}C$
Operating Temperature	$T_A$	0 to + 70	$^{\circ}C$
Storage Temperature — Plastic	$T_{stg}$	- 55 to + 125	$^{\circ}C$

This is a synchronous device. All synchronous inputs must meet specified setup and hold times with stable logic levels for **ALL** rising edges of clock (K) while the device is selected.

This device contains circuitry to protect the inputs against damage due to high static voltages or electric fields; however, it is advised that normal precautions be taken to avoid application of any voltage higher than maximum rated voltages to these high-impedance circuits.

NOTE: Permanent device damage may occur if ABSOLUTE MAXIMUM RATINGS are exceeded. Functional operation should be restricted to RECOMMENDED OPERATING CONDITIONS. Exposure to higher than recommended voltages for extended periods of time could affect device reliability.

**PACKAGE THERMAL CHARACTERISTICS** (See Note 1)

Rating		Symbol	TQFP	Unit	Notes
Junction to Ambient (@ 200 lfm)	Single-Layer Board	$R_{\theta JA}$	40	°C/W	2
	Four-Layer Board		35		
Junction to Board (Bottom)		$R_{\theta JB}$	23	°C/W	3
Junction to Case (Top)		$R_{\theta JC}$	9	°C/W	4

## NOTES:

- Junction temperature is a function of on-chip power dissipation, package thermal resistance, mounting site (board) temperature, ambient temperature, air flow, board population, and board thermal resistance.
- Per SEMI G38-87.
- Indicates the average thermal resistance between the die and the printed circuit board.
- Indicates the average thermal resistance between the die and the case top surface via the cold plate method (MIL SPEC-883 Method 1012.1).

**DC OPERATING CONDITIONS AND CHARACTERISTICS**

( $V_{DD} = 3.3 \text{ V} \pm 5\%$ ,  $T_A = 0 \text{ to } +70^\circ\text{C}$ , Unless Otherwise Noted)

**RECOMMENDED OPERATING CONDITIONS AND SUPPLY CURRENTS**

Parameter		Symbol	Min	Max	Unit
Supply Voltage (Operating Voltage Range)		$V_{DD}$	3.135	3.465	V
Input High Voltage		$V_{IH}$	2.0	$V_{DD} + 0.5^{**}$	V
Input Low Voltage		$V_{IL}$	-0.5*	0.8	V
Input Leakage Current (All Inputs, $V_{in} = 0 \text{ to } V_{DD}$ )		$I_{kg(I)}$	—	$\pm 1.0$	$\mu\text{A}$
Output Leakage Current ( $E = V_{IH}$ , $V_{out} = 0 \text{ to } V_{DD}$ )		$I_{kg(O)}$	—	$\pm 1.0$	$\mu\text{A}$
AC Supply Current ( $I_{out} = 0 \text{ mA}$ ) ( $V_{DD} = \text{max}$ , $f = f_{\text{max}}$ )	MCM69D536-6 ns	$I_{DDA}$	—	300	mA
	MCM69D536-8 ns		—	300	
CMOS Standby Supply Current (Deselected, Clock (K) Cycle Time $\geq t_{KHKH}$ , All Inputs Toggling at CMOS Levels $V_{in} \leq V_{SS} + 0.2 \text{ V}$ or $\geq V_{DD} - 0.2 \text{ V}$ )	MCM69D536-6 ns	$I_{SB1}$	—	100	mA
	MCM69D536-8 ns		—	100	
Output Low Voltage ( $I_{OL} = +8.0 \text{ mA}$ )		$V_{OL}$	—	0.4	V
Output High Voltage ( $I_{OH} = -4.0 \text{ mA}$ )		$V_{OH}$	2.4	$V_{DD}$	V

\*  $V_{IL} \geq -1.5 \text{ V}$  for  $t \leq t_{KHKH}/2$ .

\*\*  $V_{IH} \leq V_{DD} + 1.0 \text{ V}$  for  $t \leq t_{KHKH}/2$ .

**CAPACITANCE** ( $f = 1.0 \text{ MHz}$ ,  $dV = 3.0 \text{ V}$ ,  $T_A = 0 \text{ to } 70^\circ\text{C}$ , Periodically Sampled Rather Than 100% Tested)

Parameter	Symbol	Max	Unit
Address and Data Input Capacitance	$C_{in}$	6	pF
Control Pin Input Capacitance	$C_{in}$	6	pF
Output Capacitance	$C_{out}$	8	pF

## AC OPERATING CONDITIONS AND CHARACTERISTICS

( $V_{DD} = 3.3\text{ V} \pm 5\%$ ,  $T_A = 0\text{ to } +70^\circ\text{C}$ , Unless Otherwise Noted)

Input Timing Measurement Reference Level ..... 1.5 V  
 Input Pulse Levels ..... 0 to 3.0 V  
 Input Rise/Fall Time ..... 3 ns

Output Timing Reference Level ..... 1.5 V  
 Output Load ..... Figure 1 Unless Otherwise Noted

### READ/WRITE CYCLE TIMING (See Notes 1, 2, and 3)

Parameter	Symbol	MCM69D536-6		MCM69D536-8		Unit	Notes	
		Min	Max	Min	Max			
Cycle Time	$t_{KHKH}$	12	—	15	—	ns	1	
Clock Access Time	$t_{KHQV}$	—	6	—	8	ns		
Clock Low Pulse Width	$t_{KLKH}$	4	—	6	—	ns		
Clock High Pulse Width	$t_{KHKL}$	4	—	6	—	ns		
Clock High to Data Output Active	$t_{KHQX1}$	0	—	0	—	ns		
Clock High to Data Output Invalid	$t_{KHQX2}$	2	—	2	—	ns		
Clock High to Data Output High-Z	$t_{KHQZ}$	—	5	—	5	ns	2	
Output Enable Low to Data Output Valid	$t_{GLQV}$	—	6	—	8	ns		
Output Enable Low to Data Output Low-Z	$t_{GLQX}$	0	—	0	—	ns		
Output Enable High to Data Output High-Z	$t_{GHQZ}$	—	5	—	8	ns	2	
Setup Times:	AWR0 – AWR14 ARD0 – ARD14 $\underline{W}$ PT E1, E2 D0 – D35	$t_{AVKH}$ $t_{AVKH}$ $t_{WVKH}$ $t_{PTVKH}$ $t_{EVKH}$ $t_{DVKH}$	2.5	—	3	—	ns	3
Hold Times:	AWR0 – AWR14 ARD0 – ARD14 $\underline{W}$ PT E1, E2 D0 – D35	$t_{KHAX}$ $t_{KHAX}$ $t_{KH WX}$ $t_{KHPTX}$ $t_{KH EX}$ $t_{KHDX}$	0.5	—	1	—	ns	3 3 3 3 3 3, 4

**NOTES:**

1. All read and write cycles are referenced from K.
2. This parameter is sampled and not 100% tested.
3. This is a synchronous device. All synchronous inputs must meet the specified setup and hold times with stable logic levels for **ALL** rising edges of clock (K) while the device is selected.
4.  $t_{KHDX}$  minimum for Port Y only extends to 4.0 ns only for the special case when the Y- and X-address are identical on the same rising clock edge.

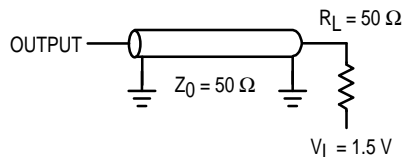

**Figure 1. AC Test Load**

**READ CYCLE TIMING FROM BOTH PORTS (WX, WY, PTX, PTY HIGH)**

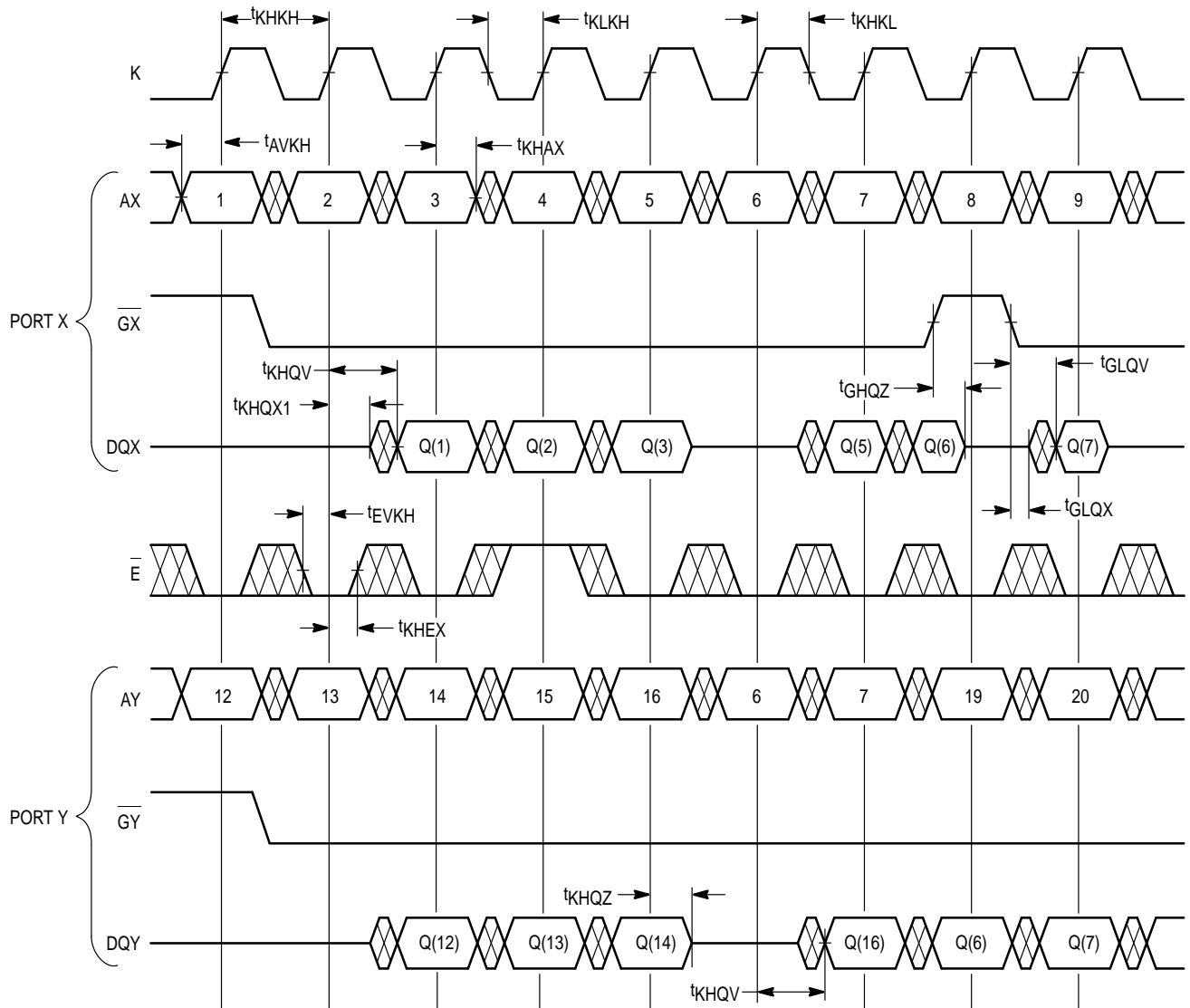

NOTE:  $\bar{E}$  Low =  $\bar{E}1$  Low and E2 High.  $\bar{E}$  High =  $\bar{E}1$  High or E2 Low.



**WRITE CYCLE TIMING TO BOTH PORTS (PTX, PTY HIGH)**

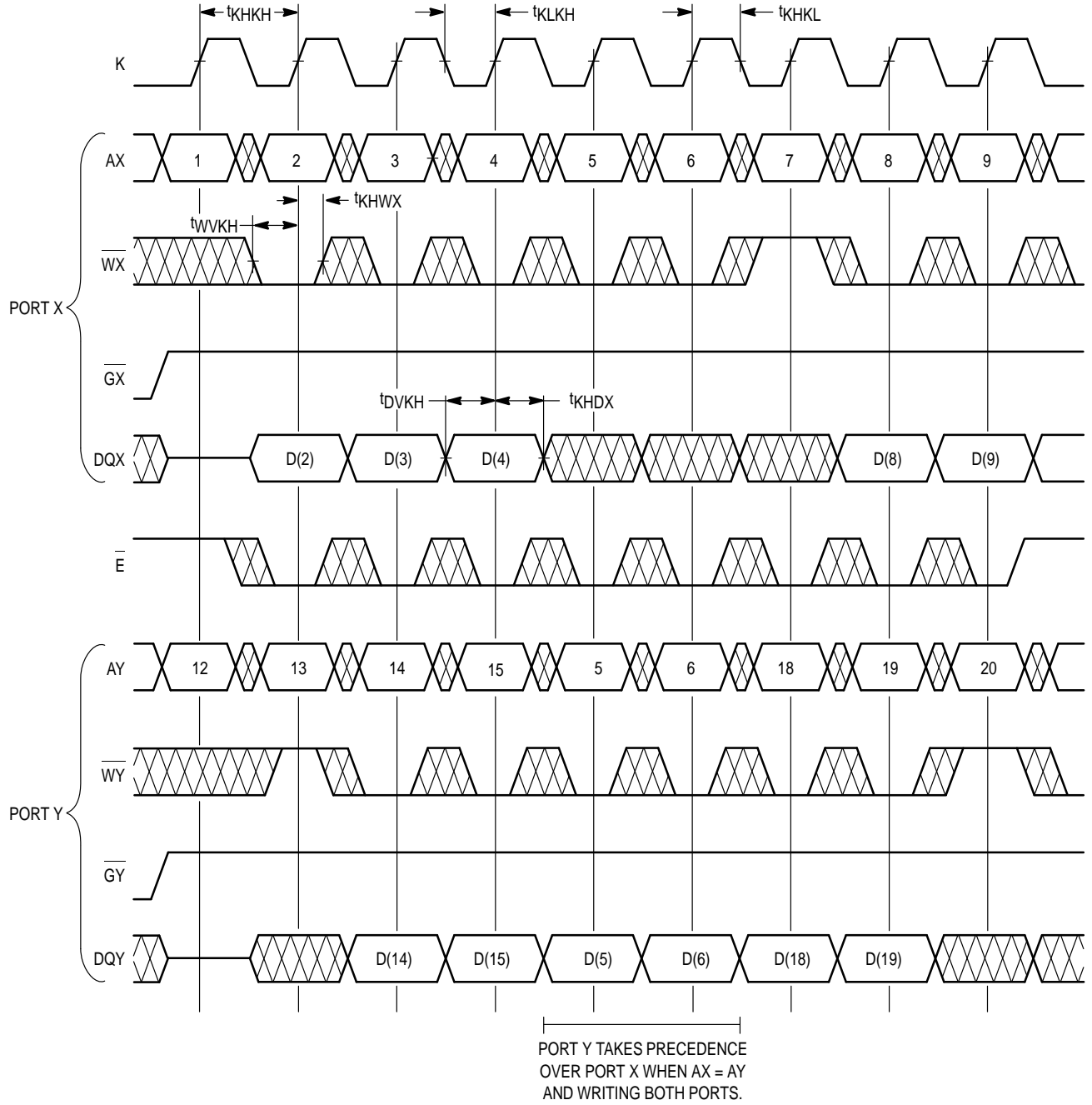

NOTE:  $\bar{E}$  Low =  $\bar{E}1$  Low and  $\bar{E}2$  High.  $\bar{E}$  High =  $\bar{E}1$  High or  $\bar{E}2$  Low.

**WRITE TO PORT X AND PASS-THROUGH TO PORT Y (SEE NOTE)**

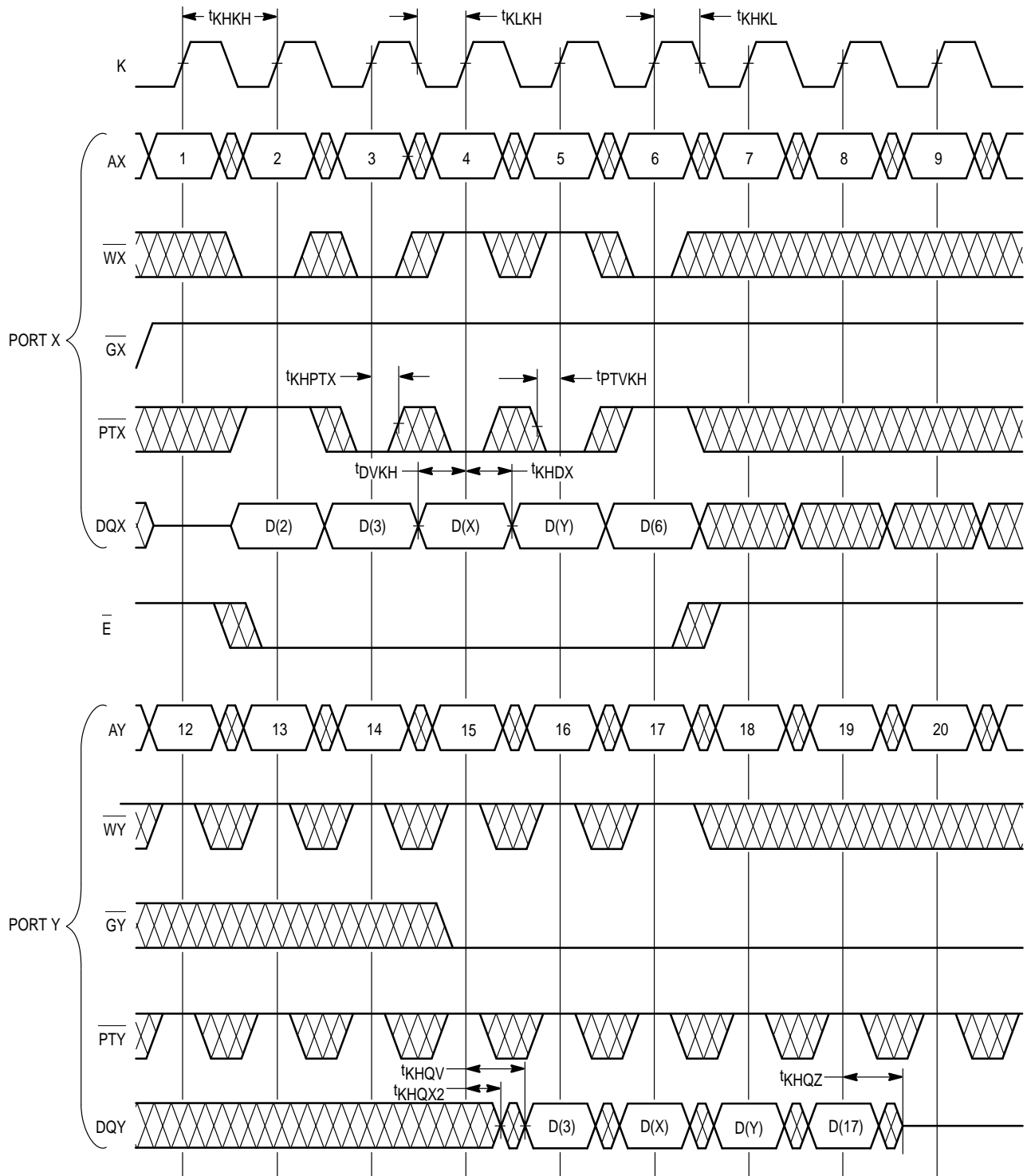

$\overline{E}$  Low =  $\overline{E1}$  Low and  $\overline{E2}$  High.  $\overline{E}$  High =  $\overline{E1}$  High or  $\overline{E2}$  Low.

NOTE: The timing diagram is valid for the opposite case as well, i.e., writing to Port Y and passing through to Port X.

### COMBINATION READ/WRITE WITH SAME ADDRESS ON EACH PORT

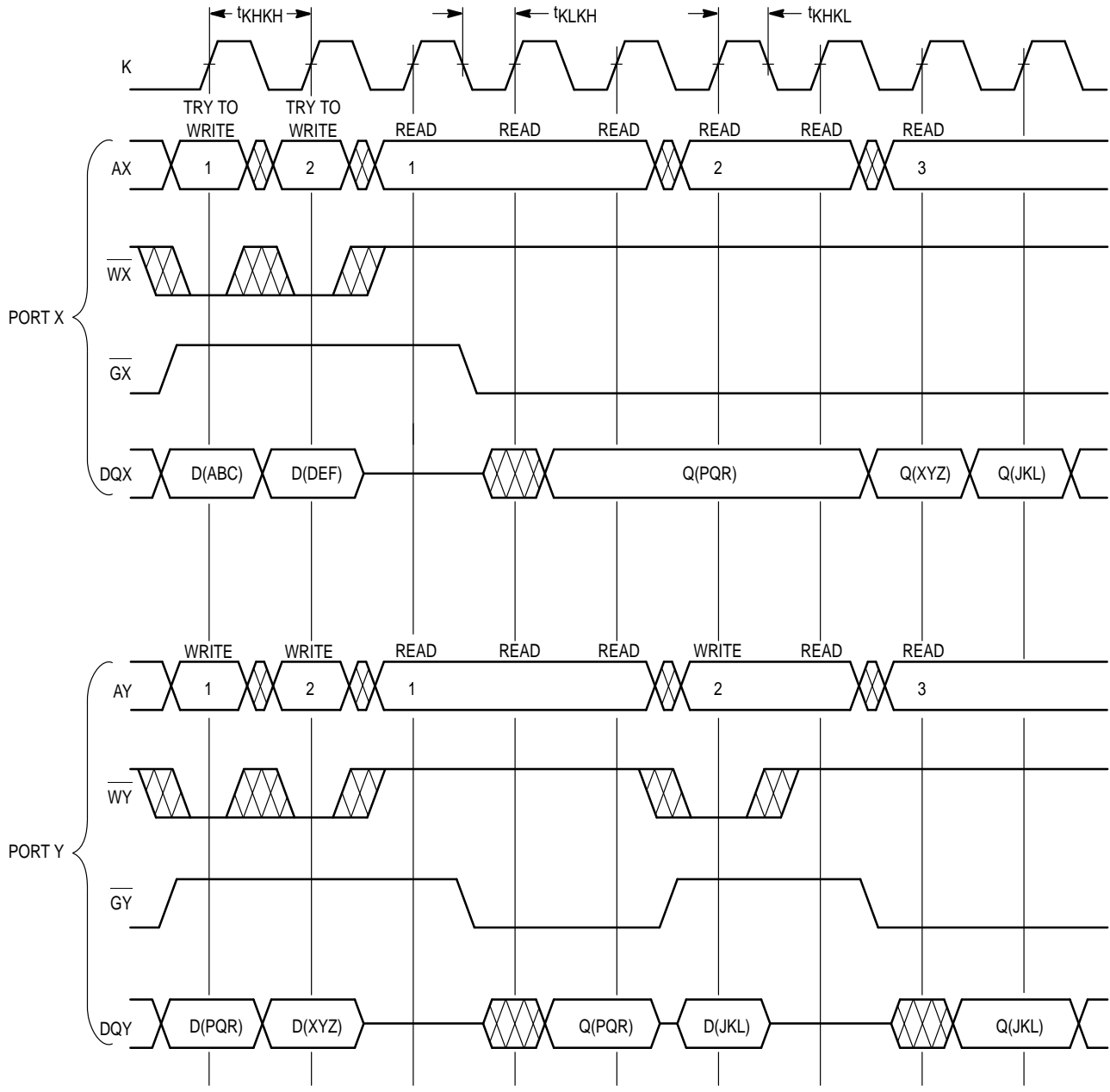

PORT Y TAKES PRECEDENCE  
OVER PORT X WHEN AX = AY  
AND WRITING BOTH PORTS.

$\overline{PTX} = \overline{PTY} = \text{high}$ .

D(Value) = Value is the input to the data port.

Q(Value) = Value is the output from the data port.

**ORDERING INFORMATION**  
**(Order by Full Part Number)**

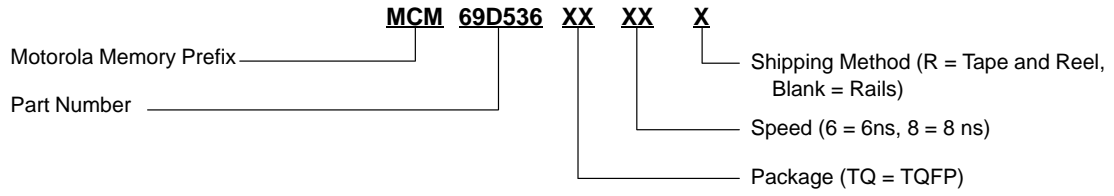

Full Part Numbers — MCM69D536TQ6    MCM69D536TQ8  
                          MCM69D536TQ6R    MCM69D536TQ8R

# PACKAGE DIMENSIONS

## TQFP PACKAGE 176 LEAD CASE 1101-01

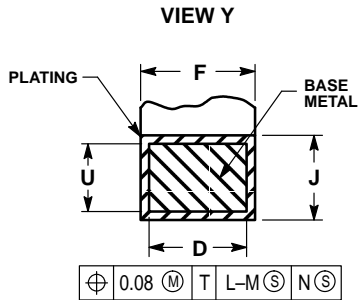
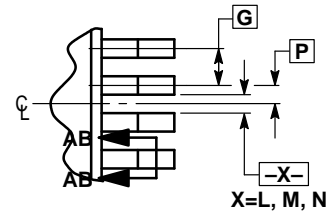
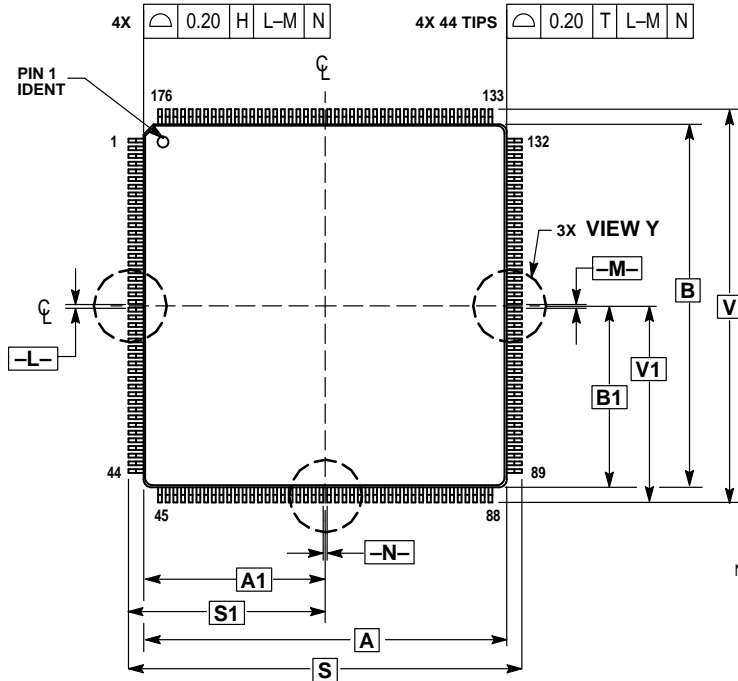

**SECTION AB-AB**  
ROTATED 90° CLOCKWISE

**NOTES:**

1. DIMENSIONING AND TOLERANCING PER ANSI Y14.5M, 1982.
2. CONTROLLING DIMENSION: MILLIMETER.
3. DATUM PLANE -H- IS LOCATED AT BOTTOM OF LEAD AND IS COINCIDENT WITH THE LEAD WHERE THE LEAD EXITS THE PLASTIC BODY AT THE BOTTOM OF THE PARTING LINE.
4. DATUMS -L-, -M-, AND -N- TO BE DETERMINED AT DATUM PLANE -H-.
5. DIMENSIONS S AND V TO BE DETERMINED AT SEATING PLANE -T-.
6. DIMENSIONS A AND B DO NOT INCLUDE MOLD PROTRUSION. ALLOWABLE PROTRUSION IS 0.25 (0.010) PER SIDE. DIMENSIONS A AND B DO INCLUDE MOLD MISMATCH AND ARE DETERMINED AT DATUM PLANE -H-.
7. DIMENSION D DOES NOT INCLUDE DAMBAR PROTRUSION. DAMBAR PROTRUSION SHALL NOT CAUSE THE LEAD WIDTH TO EXCEED 0.35 (0.014) MINIMUM SPACE BETWEEN PROTRUSION AND ADJACENT LEAD 0.07 (0.003).

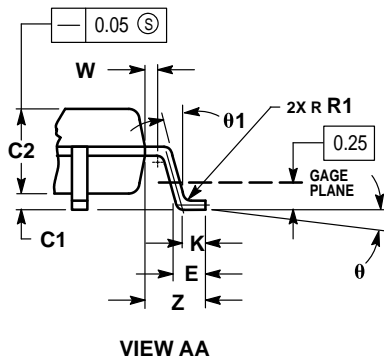
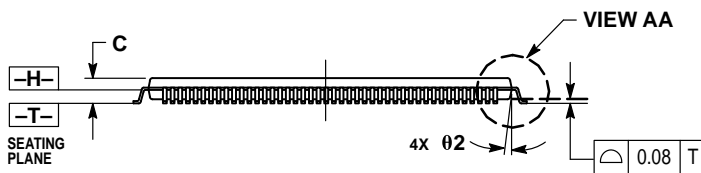

MILLIMETERS		
DIM	MIN	MAX
A	24.00 BSC	
A1	12.00 BSC	
B	24.00 BSC	
B1	12.00 BSC	
C	—	1.60
C1	0.05	—
C2	1.35	1.45
D	0.17	0.23
E	0.45	0.75
F	0.17	0.27
G	0.50 BSC	
J	0.09	0.20
K	0.50 REF	
P	0.25 BSC	
R1	0.10	0.20
S	26.00 BSC	
S1	13.00 BSC	
U	0.09	0.16
V	26.00 BSC	
V1	13.00 BSC	
W	0.20 REF	
Z	1.00 REF	
θ	0°	7°
θ1	0°	
θ2	12° REF	

Motorola reserves the right to make changes without further notice to any products herein. Motorola makes no warranty, representation or guarantee regarding the suitability of its products for any particular purpose, nor does Motorola assume any liability arising out of the application or use of any product or circuit, and specifically disclaims any and all liability, including without limitation consequential or incidental damages. "Typical" parameters which may be provided in Motorola data sheets and/or specifications can and do vary in different applications and actual performance may vary over time. All operating parameters, including "Typicals" must be validated for each customer application by customer's technical experts. Motorola does not convey any license under its patent rights nor the rights of others. Motorola products are not designed, intended, or authorized for use as components in systems intended for surgical implant into the body, or other applications intended to support or sustain life, or for any other application in which the failure of the Motorola product could create a situation where personal injury or death may occur. Should Buyer purchase or use Motorola products for any such unintended or unauthorized application, Buyer shall indemnify and hold Motorola and its officers, employees, subsidiaries, affiliates, and distributors harmless against all claims, costs, damages, and expenses, and reasonable attorney fees arising out of, directly or indirectly, any claim of personal injury or death associated with such unintended or unauthorized use, even if such claim alleges that Motorola was negligent regarding the design or manufacture of the part. Motorola and  are registered trademarks of Motorola, Inc. Motorola, Inc. is an Equal Opportunity/Affirmative Action Employer.

Mfax is a trademark of Motorola, Inc.

**How to reach us:**

**USA/EUROPE/Locations Not Listed:** Motorola Literature Distribution;  
P.O. Box 5405, Denver, Colorado, 80217. 1-303-675-2140 or 1-800-441-2447

**Mfax™:** RMFAX0@email.sps.mot.com – TOUCHTONE 1-602-244-6609  
Motorola Fax Back System – US & Canada ONLY 1-800-774-1848  
– <http://sps.motorola.com/mfax/>

**HOME PAGE:** <http://motorola.com/sps/>

**JAPAN:** Nippon Motorola Ltd.: SPD, Strategic Planning Office, 141,  
4-32-1 Nishi-Gotanda, Shagawa-ku, Tokyo, Japan. 03-5487-8488

**ASIA/PACIFIC:** Motorola Semiconductors H.K. Ltd.; 8B Tai Ping Industrial Park,  
51 Ting Kok Road, Tai Po, N.T., Hong Kong. 852-26629298

**CUSTOMER FOCUS CENTER:** 1-800-521-6274



**MOTOROLA**