

DATA SHEET



PCA9539

16-bit I²C and SMBus, low power I/O port
with interrupt and reset

Product data sheet
Supersedes data of 2004 Aug 27

2004 Sep 30



16-bit I²C and SMBus, low power I/O port with interrupt and reset

PCA9539

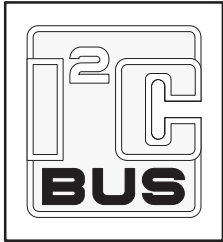

FEATURES

- 16-bit I²C GPIO with interrupt and reset
- Operating power supply voltage range of 2.3 V–5.5 V
- 5 V tolerant I/Os
- Polarity inversion register
- Active LOW interrupt output
- Active LOW reset input
- Low stand-by current
- Noise filter on SCL/SDA inputs
- No glitch on power-up
- Internal power-on reset
- 16 I/O pins which default to 16 inputs
- 0 kHz to 400 kHz clock frequency
- ESD protection exceeds 2000 V HBM per JESD22-A114, 200 V MM per JESD22-A115, and 1000 V CDM per JESD22-C101
- Latch-up testing is done to JESDEC Standard JESD78 which exceeds 100 mA
- Offered in three different packages: SO24, TSSOP24, and HVQFN24

ORDERING INFORMATION

PACKAGES	TEMPERATURE RANGE	ORDER CODE	TOPSIDE MARK	DRAWING NUMBER
24-Pin Plastic SO	–40 °C to +85 °C	PCA9539D	PCA9539D	SOT137-1
24-Pin Plastic TSSOP	–40 °C to +85 °C	PCA9539PW	PCA9539PW	SOT355-1
24-Pin Plastic HVQFN	–40 °C to +85 °C	PCA9539BS	9539	SOT616-1

Standard packing quantities and other packing data are available at www.standardproducts.philips.com/packaging.

I²C is a trademark of Philips Semiconductors Corporation.

SMBus as specified by the Smart Battery System Implementers Forum is a derivative of the Philips I²C patent.

DESCRIPTION

The PCA9539 is a 24-pin CMOS device that provide 16 bits of General Purpose parallel Input/Output (GPIO) expansion with interrupt and reset for I²C/SMBus applications and was developed to enhance the Philips family of I²C I/O expanders. I/O expanders provides a simple solution when additional I/O is needed for ACPI power switches, sensors, pushbuttons, LEDs, fans, etc.

The PCA9539 consists of two 8-bit Configuration (Input or Output selection); Input, Output and Polarity inversion (Active HIGH or Active LOW operation) registers. The system master can enable the I/Os as either inputs or outputs by writing to the I/O configuration bits. The data for each Input or Output is kept in the corresponding Input or Output register. The polarity of the read register can be inverted with the Polarity Inversion Register. All registers can be read by the system master.

The PCA9539 is identical to the PCA9555 except for the removal of the internal I/O pull-up resistor which greatly reduces power consumption when the I/Os are held LOW, replacement of A2 with RESET and different address range.

The PCA9539 open-drain interrupt output is activated when any input state differs from its corresponding input port register state and is used to indicate to the system master that an input state has changed. The power-on reset sets the registers to their default values and initializes the device state machine. The RESET pin causes the same reset/configuration to occur without depowering the device.

Two hardware pins (A0, A1) vary the fixed I²C address and allow up to four devices to share the same I²C/SMBus.

16-bit I²C and SMBus, low power I/O port with interrupt and reset

PCA9539

PIN CONFIGURATION — SO, TSSOP

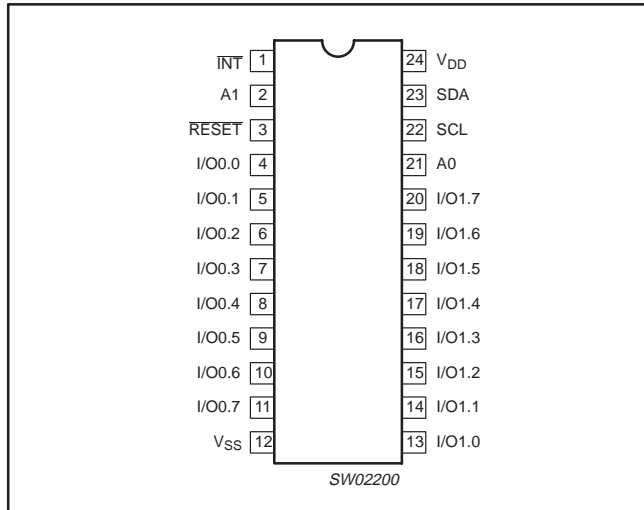

Figure 1. Pin configuration — SO, TSSOP

PIN CONFIGURATION — HVQFN

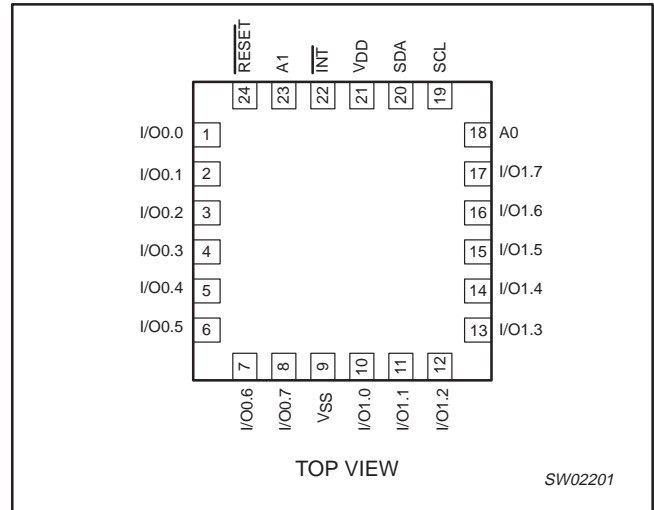

Figure 2. Pin configuration — HVQFN

PIN DESCRIPTION

SO, TSSOP PIN NUMBER	HVQFN PIN NUMBER	SYMBOL	FUNCTION
1	22	$\overline{\text{INT}}$	Interrupt output (open drain)
2	23	A1	Address input 1
3	24	RESET	Active LOW reset input
4–11	1–8	I/O0.0–I/O0.7	I/O0.0 to I/O0.7
12	9	V _{SS}	Supply ground
13–20	10–17	I/O1.0–I/O1.7	I/O1.0 to I/O1.7
21	18	A0	Address input 0
22	19	SCL	Serial clock line
23	20	SDA	Serial data line
24	21	V _{DD}	Supply voltage

16-bit I²C and SMBus, low power I/O port with interrupt and reset

PCA9539

BLOCK DIAGRAM

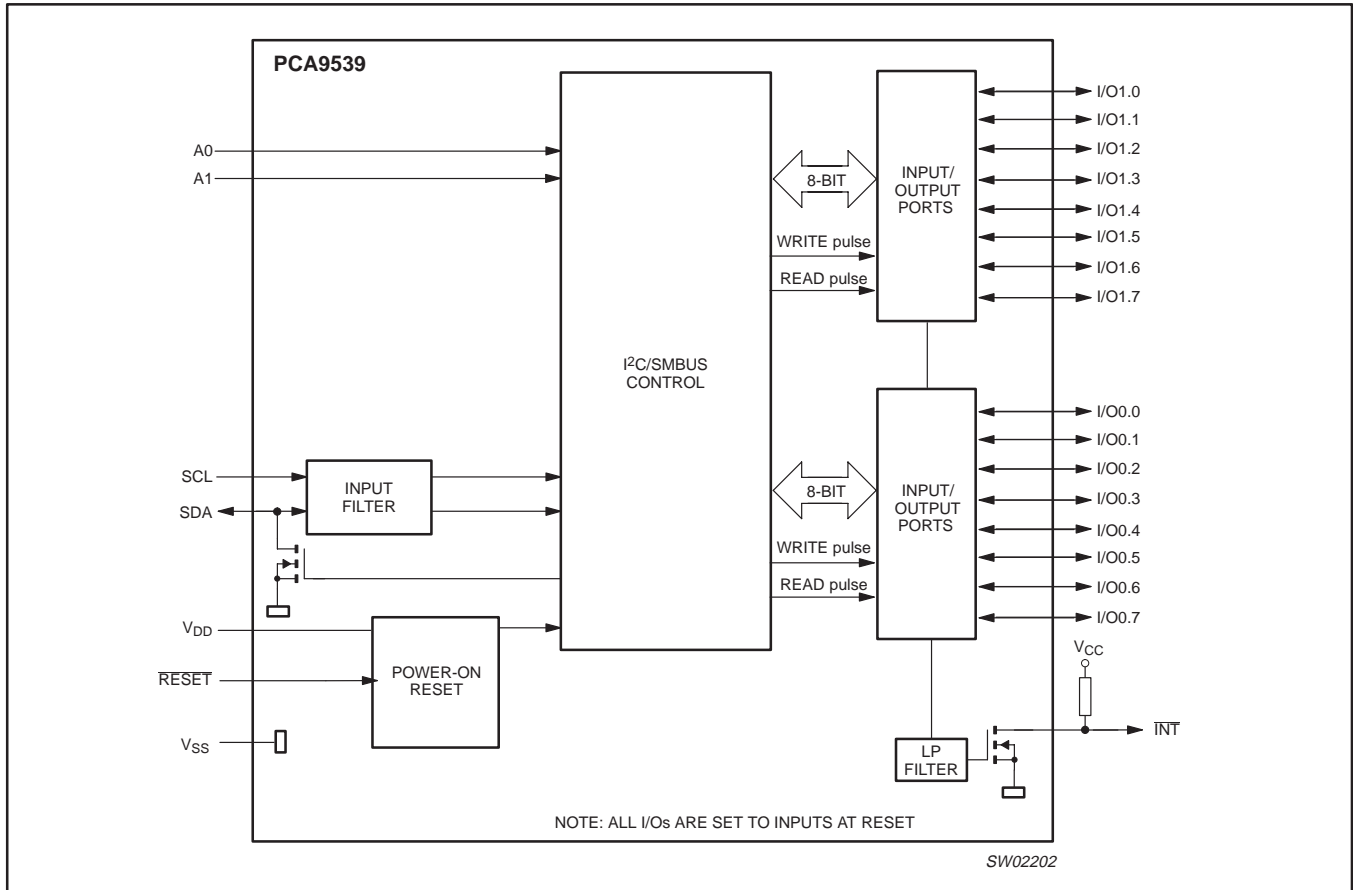
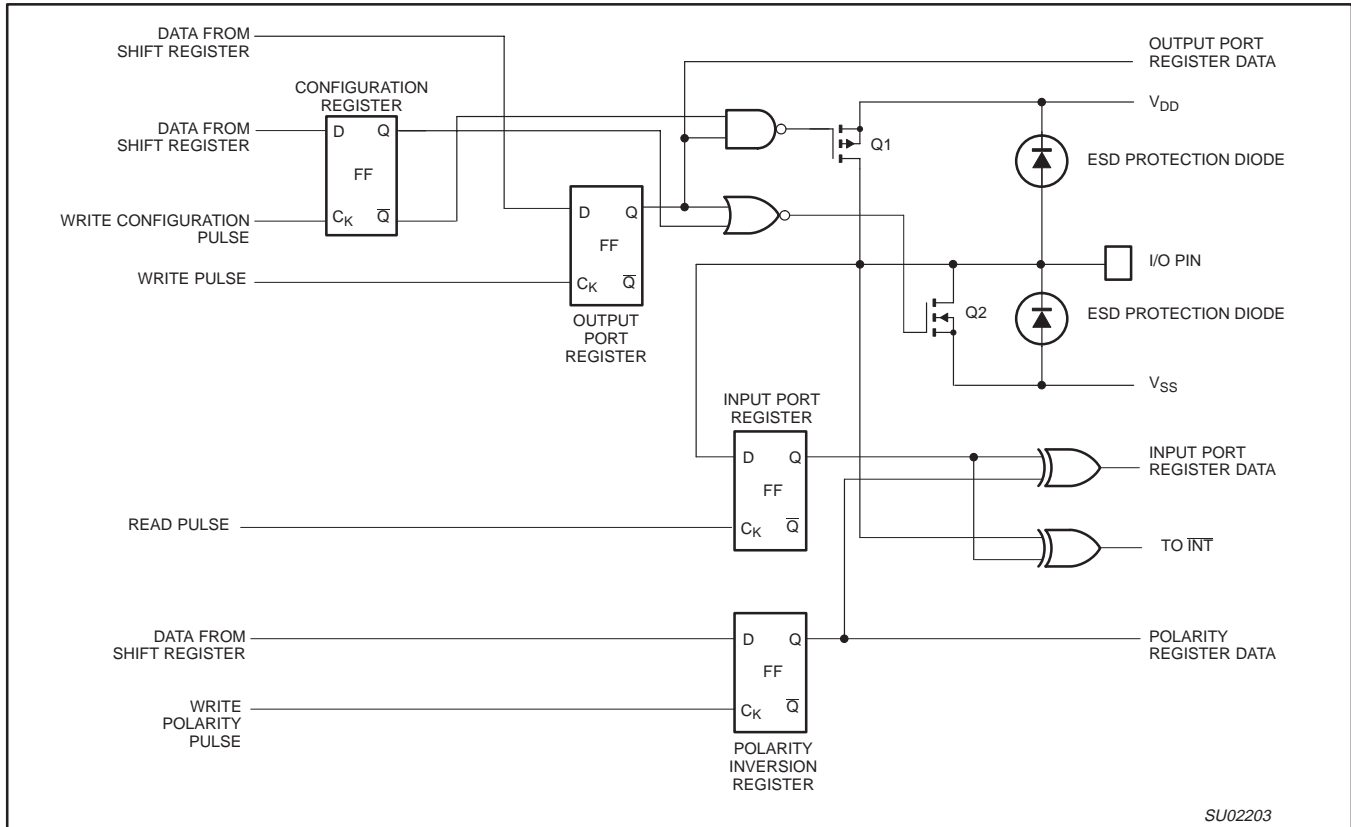

Figure 3. Block diagram

16-bit I²C and SMBus, low power I/O port with interrupt and reset

PCA9539

SIMPLIFIED SCHEMATIC OF I/Os



SU02203

NOTE: At Power-on Reset, all registers return to default values.

Figure 4. Simplified schematic of I/Os

I/O port

When an I/O is configured as an input, FETs Q1 and Q2 are off, creating a high impedance input. The input voltage may be raised above V_{DD} to a maximum of 5.5 V.

If the I/O is configured as an output, then either Q1 or Q2 is on, depending on the state of the Output Port register. Care should be exercised if an external voltage is applied to an I/O configured as an output because of the low impedance path that exists between the pin and either V_{DD} or V_{SS} .

16-bit I²C and SMBus, low power I/O port with interrupt and reset

PCA9539

REGISTERS

Command Byte

Command	Register
0	Input port 0
1	Input port 1
2	Output port 0
3	Output port 1
4	Polarity inversion port 0
5	Polarity inversion port 1
6	Configuration port 0
7	Configuration port 1

The command byte is the first byte to follow the address byte during a write transmission. It is used as a pointer to determine which of the following registers will be written or read.

Registers 0 and 1 — Input Port Registers

bit	I0.7	I0.6	I0.5	I0.4	I0.3	I0.2	I0.1	I0.0
default	X	X	X	X	X	X	X	X
bit	I1.7	I1.6	I1.5	I1.4	I1.3	I1.2	I1.1	I1.0
default	X	X	X	X	X	X	X	X

This register is an input-only port. It reflects the incoming logic levels of the pins, regardless of whether the pin is defined as an input or an output by Register 3. Writes to this register have no effect.

The default value 'X' is determined by the externally applied logic level.

Registers 2 and 3 — Output Port Registers

bit	O0.7	O0.6	O0.5	O0.4	O0.3	O0.2	O0.1	O0.0
default	1	1	1	1	1	1	1	1
bit	O1.7	O1.6	O1.5	O1.4	O1.3	O1.2	O1.1	O1.0
default	1	1	1	1	1	1	1	1

This register is an output-only port. It reflects the outgoing logic levels of the pins defined as outputs by Register 6 and 7. Bit values in this register have no effect on pins defined as inputs. In turn, reads from this register reflect the value that is in the flip-flop controlling the output selection, NOT the actual pin value.

Registers 4 and 5 — Polarity Inversion Registers

bit	N0.7	N0.6	N0.5	N0.4	N0.3	N0.2	N0.1	N0.0
default	0	0	0	0	0	0	0	0
bit	N1.7	N1.6	N1.5	N1.4	N1.3	N1.2	N1.1	N1.0
default	0	0	0	0	0	0	0	0

This register allows the user to invert the polarity of the Input Port register data. If a bit in this register is set (written with '1'), the Input Port data polarity is inverted. If a bit in this register is cleared (written with a '0'), the Input Port data polarity is retained.

Registers 6 and 7 — Configuration Registers

bit	C0.7	C0.6	C0.5	C0.4	C0.3	C0.2	C0.1	C0.0
default	1	1	1	1	1	1	1	1

bit	C1.7	C1.6	C1.5	C1.4	C1.3	C1.2	C1.1	C1.0
default	1	1	1	1	1	1	1	1

This register configures the directions of the I/O pins. If a bit in this register is set (written with '1'), the corresponding port pin is enabled as an input with high impedance output driver. If a bit in this register is cleared (written with '0'), the corresponding port pin is enabled as an output. At reset the device's ports are inputs.

POWER-ON RESET

When power is applied to V_{DD}, an internal power-on reset holds the PCA9539 in a reset condition until V_{DD} has reached V_{POR}. At that point, the reset condition is released and the PCA9539 registers and SMBus state machine will initialize to their default states. Therefore, V_{DD} must be lowered below 0.2 V to reset the device.

For a power reset cycle, V_{DD} must be lowered below 0.2 V and then restored to the operating voltage.

RESET Input

A reset can be accomplished by holding the **RESET** pin LOW for a minimum of t_W. The PCA9539 registers and SMBus/I²C state machine will be held in their default state until the **RESET** input is once again HIGH. This input typically requires a pull-up to V_{DD}.

DEVICE ADDRESS

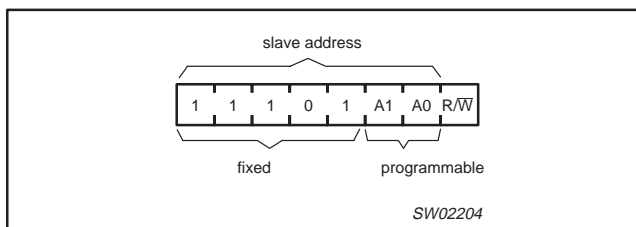

Figure 5. PCA9539 address

16-bit I²C and SMBus, low power I/O port with interrupt and reset

PCA9539

BUS TRANSACTIONS

Writing to the port registers

Data is transmitted to the PCA9539 by sending the device address and setting the least significant bit to a logic 0 (see Figure 5 for device address). The command byte is sent after the address and determines which register will receive the data following the command byte.

The eight registers within the PCA9539 are configured to operate as four register pairs. The four pairs are Input Ports, Output Ports, Polarity Inversion Ports, and Configuration Ports. After sending data to one register, the next data byte will be sent to the other register in the pair (see Figures 6 and 7). For example, if the first byte is sent to Output Port (register 3), then the next byte will be stored in Output Port 0 (register 2). There is no limitation on the number of data bytes sent in one write transmission. In this way, each 8-bit register may be updated independently of the other registers.

Reading the port registers

In order to read data from the PCA9539, the bus master must first send the PCA9539 address with the least significant bit set to a logic 0 (see Figure 5 for device address). The command byte is sent after the address and determines which register will be accessed.

After a restart, the device address is sent again but this time, the least significant bit is set to a logic 1. Data from the register defined by the command byte will then be sent by the PCA9539 (see Figures 8, 9, and 10). Data is clocked into the register on the falling edge of the acknowledge clock pulse. After the first byte is read, additional bytes may be read but the data will now reflect the information in the other register in the pair. For example, if you read Input Port 1, then the next byte read would be Input Port 0. There is no limitation on the number of data bytes received in one read transmission but the final byte received, the bus master must not acknowledge the data.

Interrupt Output

The open-drain interrupt output is activated when one of the port pins change state and the pin is configured as an input. The interrupt is deactivated when the input returns to its previous state or the input port register is read (see Figure 9). A pin configured as an output cannot cause an interrupt. Since each 8-bit port is read independently, the interrupt caused by Port 0 will not be cleared by a read of Port 1 or the other way around.

Note that changing an I/O from an output to an input may cause a false interrupt to occur if the state of the pin does not match the contents of the Input Port register.

16-bit I²C and SMBus, low power I/O port with interrupt and reset

PCA9539

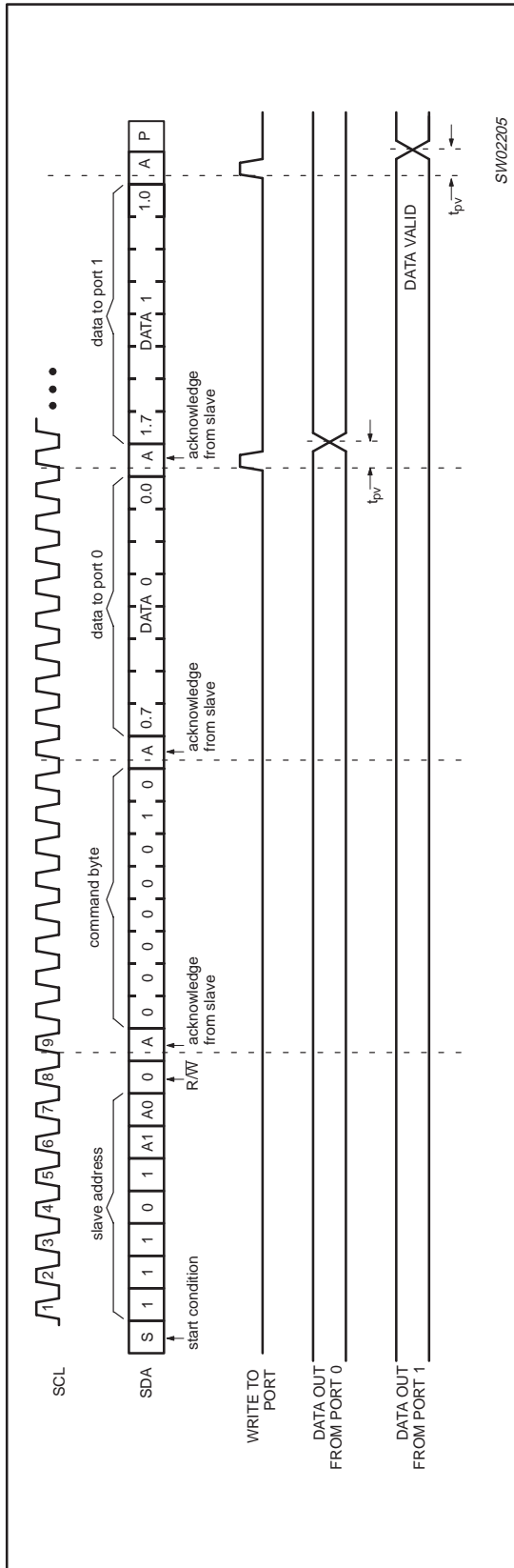

Figure 6. WRITE to output port registers

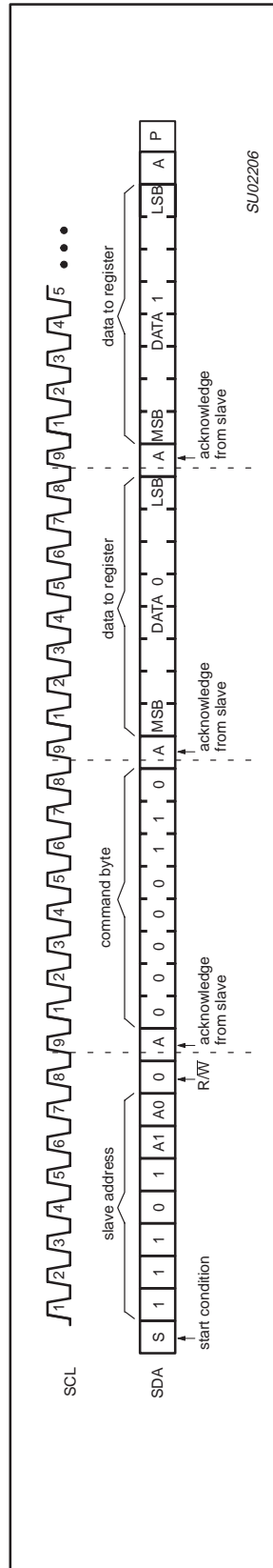

Figure 7. WRITE to configuration registers

16-bit I²C and SMBus, low power I/O port with interrupt and reset

PCA9539

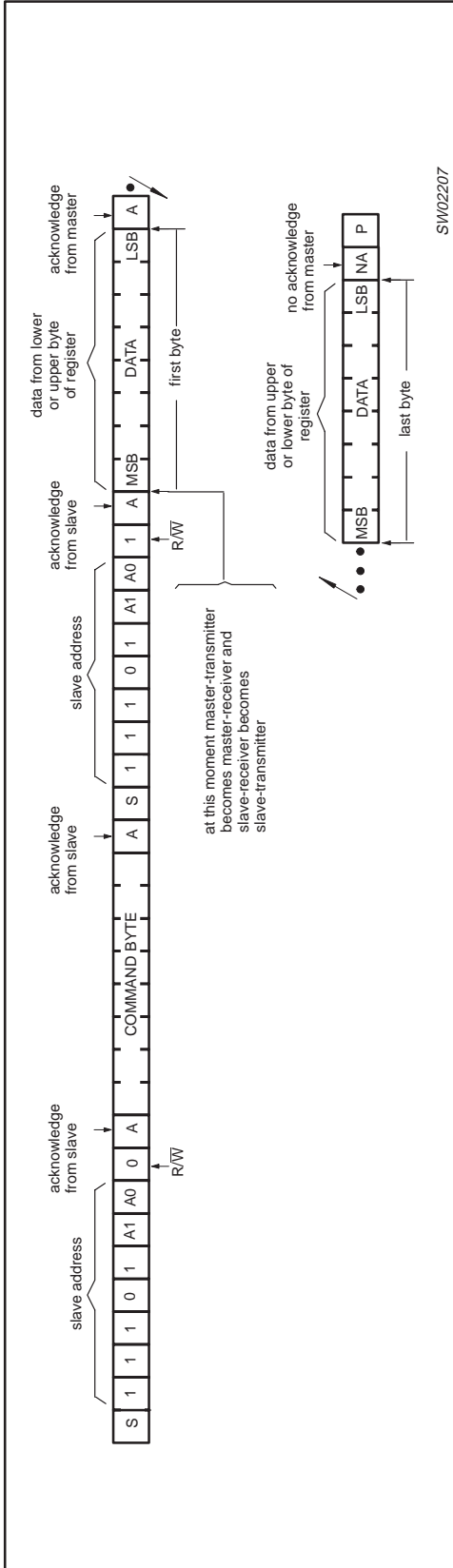

Figure 8. READ from register

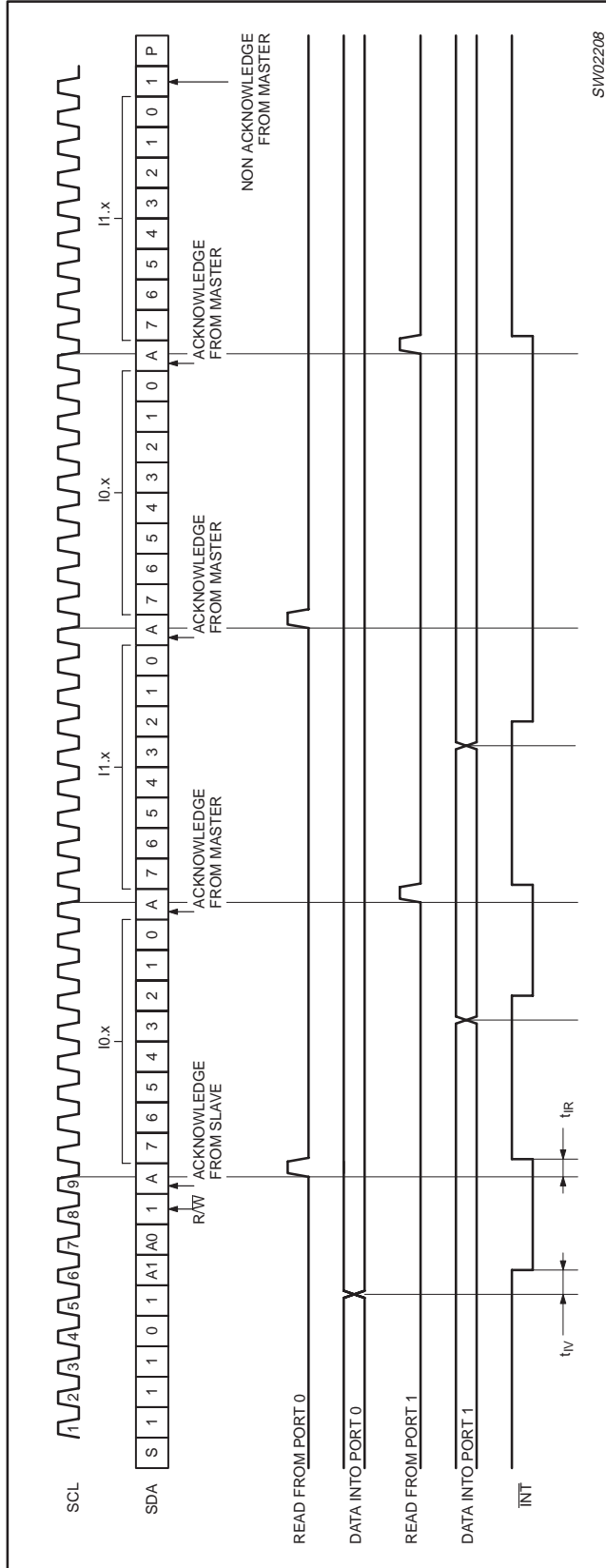
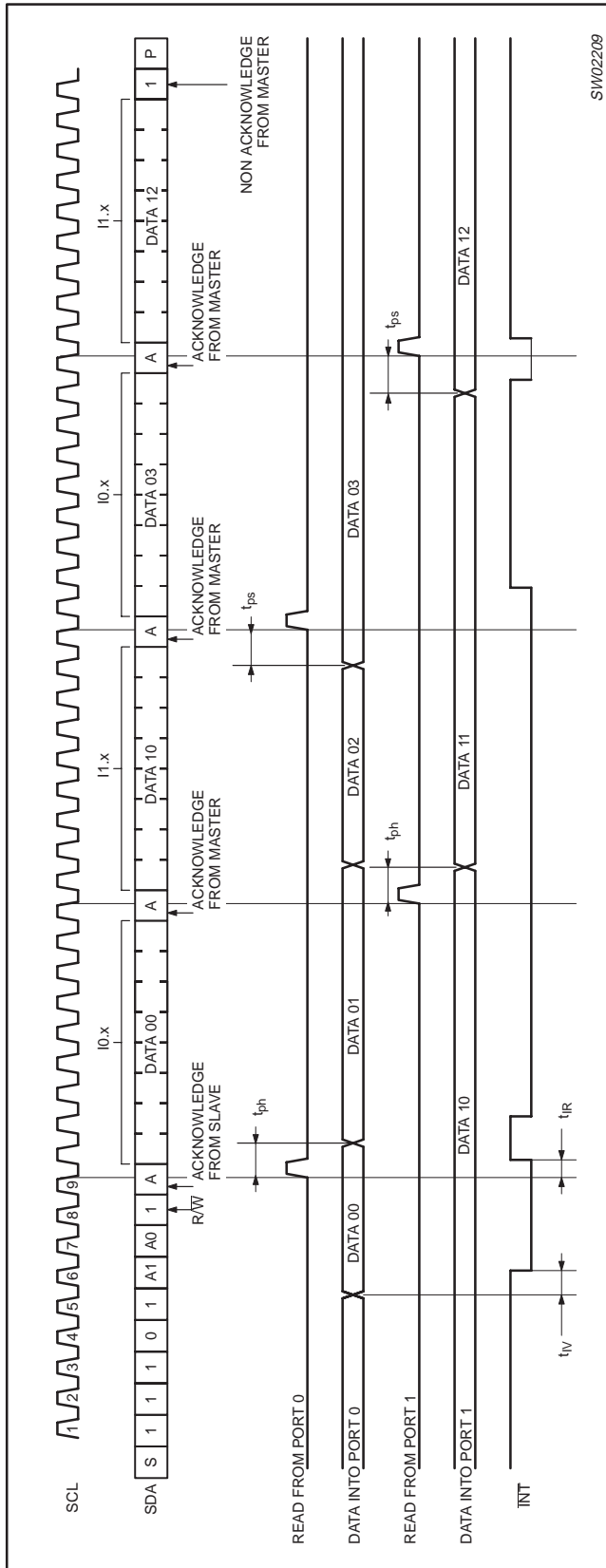

Figure 9. READ input port register — scenario 1

16-bit I²C and SMBus, low power I/O port with interrupt and reset

PCA9539



NOTES: Transfer of data can be stopped at any moment by a STOP condition. When this occurs, data present at the latest acknowledge phase is valid (output mode). It is assumed that the command byte has previously been set to 00 (read input port register).

Figure 10. READ input port register — scenario 2

16-bit I²C and SMBus, low power I/O port with interrupt

PCA9539

TYPICAL APPLICATION

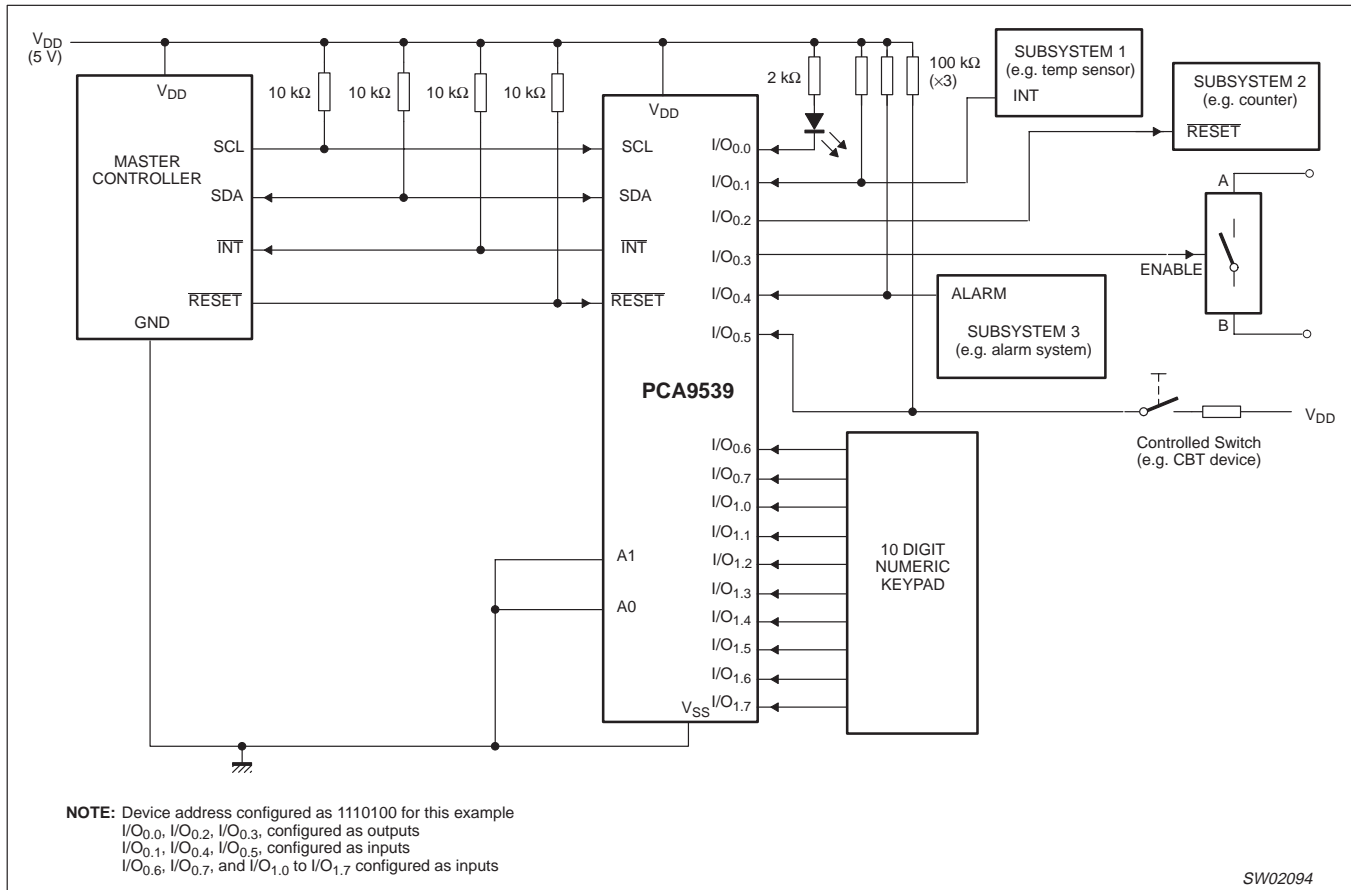

Figure 11. Typical application

Minimizing I_{DD} when the I/O is used to control LEDs

When the I/Os are used to control LEDs, they are normally connected to V_{DD} through a resistor as shown in Figure 11. Since the LED acts as a diode, when the LED is off the I/O V_{IN} is about 1.2 V less than V_{DD}. The supply current, I_{DD}, increases as V_{IN} becomes lower than V_{DD} and is specified as ΔI_{DD} in the DC characteristics table.

Designs needing to minimize current consumption, such as battery power applications, should consider maintaining the I/O pins greater than or equal to V_{DD} when the LED is off. Figure 12 shows a high value resistor in parallel with the LED. Figure 13 shows V_{DD} less than the LED supply voltage by at least 1.2 V. Both of these methods maintain the I/O V_{IN} at or above V_{DD} and prevents additional supply current consumption when the LED is off.

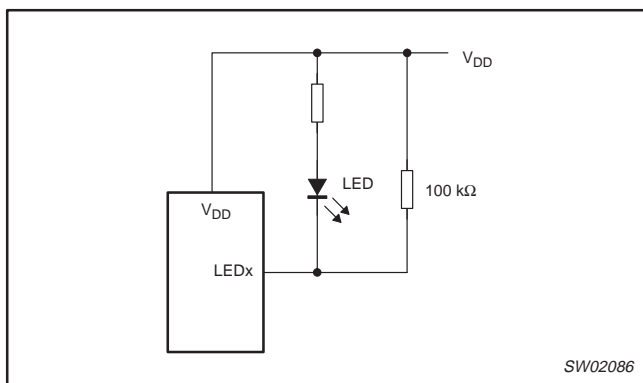

Figure 12. High value resistor in parallel with the LED

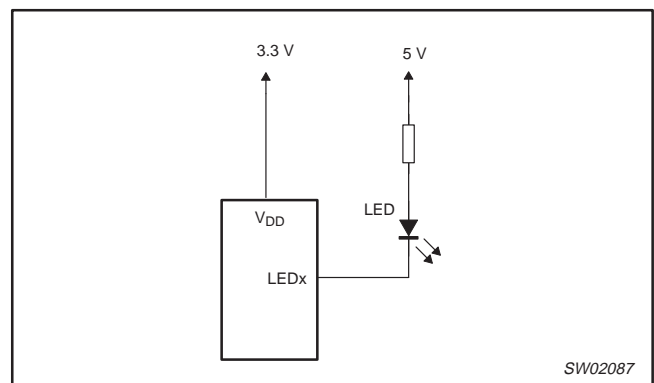

Figure 13. Device supplied by a lower voltage

16-bit I²C and SMBus, low power I/O port with interrupt

PCA9539

ABSOLUTE MAXIMUM RATINGS

In accordance with the Absolute Maximum Rating System (IEC 134)

SYMBOL	PARAMETER	CONDITIONS	MIN	MAX	UNIT
V _{DD}	Supply voltage		-0.5	6.0	V
V _{I/O}	DC input current on an I/O		V _{SS} - 0.5	6	V
I _{I/O}	DC output current on an I/O		—	± 50	mA
I _I	DC input current		—	± 20	mA
I _{DD}	Supply current		—	160	mA
I _{SS}	Supply current		—	200	mA
P _{tot}	Total power dissipation		—	200	mW
T _{stg}	Storage temperature range		-65	+150	°C
T _{amb}	Operating ambient temperature		-40	+85	°C
T _{J(MAX)}	Maximum junction temperature		—	+125	°C

16-bit I²C and SMBus, low power I/O port with interrupt

PCA9539

HANDLING

Inputs and outputs are protected against electrostatic discharge in normal handling. However, to be totally safe, it is desirable to take precautions appropriate to handling MOS devices. Advice can be found in Data Handbook IC24 under "Handling MOS devices".

DC CHARACTERISTICS

$V_{DD} = 2.3 \text{ V to } 5.5 \text{ V}$; $V_{SS} = 0 \text{ V}$; $T_{amb} = -40 \text{ }^\circ\text{C to } +85 \text{ }^\circ\text{C}$; unless otherwise specified.

SYMBOL	PARAMETER	CONDITIONS	MIN	TYP	MAX	UNIT
Supplies						
V_{DD}	Supply voltage		2.3	—	5.5	V
I_{DD}	Supply current	Operating mode; $V_{DD} = 5.5 \text{ V}$; no load; $f_{SCL} = 100 \text{ kHz}$; I/O = inputs	—	135	200	μA
I_{stbl}	Standby current	Standby mode; $V_{DD} = 5.5 \text{ V}$; no load; $V_I = V_{SS}$; $f_{SCL} = 0 \text{ kHz}$; I/O = inputs	—	0.25	1	μA
I_{stbh}	Standby current	Standby mode; $V_{DD} = 5.5 \text{ V}$; no load; $V_I = V_{DD}$; $f_{SCL} = 0 \text{ kHz}$; I/O = inputs	—	0.25	1	μA
V_{POR}	Power-on reset voltage (Note 1)	No load; $V_I = V_{DD}$ or V_{SS}	—	1.5	1.65	V
input SCL; input/output SDA						
V_{IL}	LOW-level input voltage		-0.5	—	$0.3V_{DD}$	V
V_{IH}	HIGH-level input voltage		$0.7V_{DD}$	—	5.5	V
I_{OL}	LOW-level output current	$V_{OL} = 0.4 \text{ V}$	3	tbd	—	mA
I_L	Leakage current	$V_I = V_{DD} = V_{SS}$	-1	—	+1	μA
C_I	Input capacitance	$V_I = V_{SS}$	—	6	10	pF
I/Os						
V_{IL}	LOW-level input voltage		-0.5	—	$0.3V_{DD}$	V
V_{IH}	HIGH-level input voltage		$0.7V_{DD}$	—	5.5	V
I_{OL}	LOW-level output current	$V_{OL} = 0.5 \text{ V}$; $V_{DD} = 2.3 \text{ V to } 5.5 \text{ V}$; Note 2	8	8–20	—	mA
		$V_{OL} = 0.7 \text{ V}$; $V_{DD} = 2.3 \text{ V to } 5.5 \text{ V}$; Note 2	10	10–24	—	mA
V_{OH}	HIGH-level output voltage	$I_{OH} = -8 \text{ mA}$; $V_{DD} = 2.3 \text{ V}$; Note 3	1.8	—	—	V
		$I_{OH} = -10 \text{ mA}$; $V_{DD} = 2.3 \text{ V}$; Note 3	1.7	—	—	V
		$I_{OH} = -8 \text{ mA}$; $V_{DD} = 3.0 \text{ V}$; Note 3	2.6	—	—	V
		$I_{OH} = -10 \text{ mA}$; $V_{DD} = 3.0 \text{ V}$; Note 3	2.5	—	—	V
		$I_{OH} = -8 \text{ mA}$; $V_{DD} = 4.75 \text{ V}$; Note 3	4.1	—	—	V
		$I_{OH} = -10 \text{ mA}$; $V_{DD} = 4.75 \text{ V}$; Note 3	4.0	—	—	V
I_{IH}	Input leakage current	$V_{DD} = 5.5 \text{ V}$; $V_I = V_{DD}$	—	—	1	μA
I_{IL}	Input leakage current	$V_{DD} = 5.5 \text{ V}$; $V_I = V_{SS}$	—	—	-1	μA
C_I	Input capacitance		—	3.7	5	pF
C_O	Output capacitance		—	3.7	5	pF
Interrupt INT						
I_{OL}	LOW-level output current	$V_{OL} = 0.4 \text{ V}$	3	tbd	—	mA
Select Inputs A0, A1, and RESET						
V_{IL}	LOW-level input voltage		-0.5	—	$0.3V_{DD}$	V
V_{IH}	HIGH-level input voltage		$0.7V_{DD}$	—	5.5	V
I_{LI}	Input leakage current		-1	—	1	μA

NOTES:

- V_{DD} must be lowered to 0.2 V in order to reset part.
- Each I/O must be externally limited to a maximum of 25 mA and each octal (I/O0.0 to I/O0.7, and I/O1.0 to I/O1.7) must be limited to a maximum current of 100 mA for a device total of 200 mA.
- The total current sourced by all I/Os must be limited to 160 mA (80 mA for I/O 0.0 through 0.7 and 80 mA for I/O 1.0 through 1.7).

16-bit I²C and SMBus, low power I/O port with interrupt

PCA9539

AC CHARACTERISTICS

SYMBOL	PARAMETER	STANDARD MODE I ² C-bus		FAST MODE I ² C-bus		UNITS
		MIN	MAX	MIN	MAX	
f _{SCL}	Operating frequency	0	100	0	400	kHz
t _{BUF}	Bus free time between STOP and START conditions	4.7	—	1.3	—	μs
t _{HD;STA}	Hold time after (repeated) START condition	4.0	—	0.6	—	μs
t _{SU;STA}	Repeated START condition setup time	4.7	—	0.6	—	μs
t _{SU;STO}	Set-up time for STOP condition	4.0	—	0.6	—	μs
t _{VD;ACK}	Valid time of ACK condition ²	0.3	3.45	0.1	0.9	μs
t _{HD;DAT}	Data in hold time	0	—	0	—	ns
t _{VD;DAT}	Data out valid time ³	300	—	50	—	ns
t _{SU;DAT}	Data set-up time	250	—	100	—	ns
t _{LOW}	Clock LOW period	4.7	—	1.3	—	μs
t _{HIGH}	Clock HIGH period	4.0	—	0.6	—	μs
t _F	Clock/Data fall time	—	300	20 + 0.1C _b ¹	300	ns
t _R	Clock/Data rise time	—	1000	20 + 0.1C _b ¹	300	ns
t _{SP}	Pulse width of spikes that must be suppressed by the input filters	—	50	—	50	ns
Port Timing						
t _{PV}	Output data valid	—	200	—	200	ns
t _{PS}	Input data set-up time	150	—	150	—	ns
t _{PH}	Input data hold time	1	—	1	—	μs
Interrupt Timing						
t _{IV}	Interrupt valid	—	4	—	4	μs
t _{IR}	Interrupt reset	—	4	—	4	μs
RESET						
t _W	Reset pulse width	4	—	4	—	ns
t _{REC}	Reset recovery time	0	—	0	—	ns
t _{RESET} ^{5,6}	Time to reset	400	—	400	—	ns

NOTES:

1. C_b = total capacitance of one bus line in pF.
2. t_{VD;ACK} = time for Acknowledgement signal from SCL LOW to SDA (out) LOW.
3. t_{VD;DAT} = minimum time for SDA data out to be valid following SCL LOW.
4. t_{PV} measured from 0.7V_{DD} on SCL to 50% I/O output.
5. Resetting the device while actively communicating on the bus may cause glitches or errant STOP conditions.
6. Upon reset, the full delay will be the sum of t_{RESET} and the RC time constant of the SDA bus.

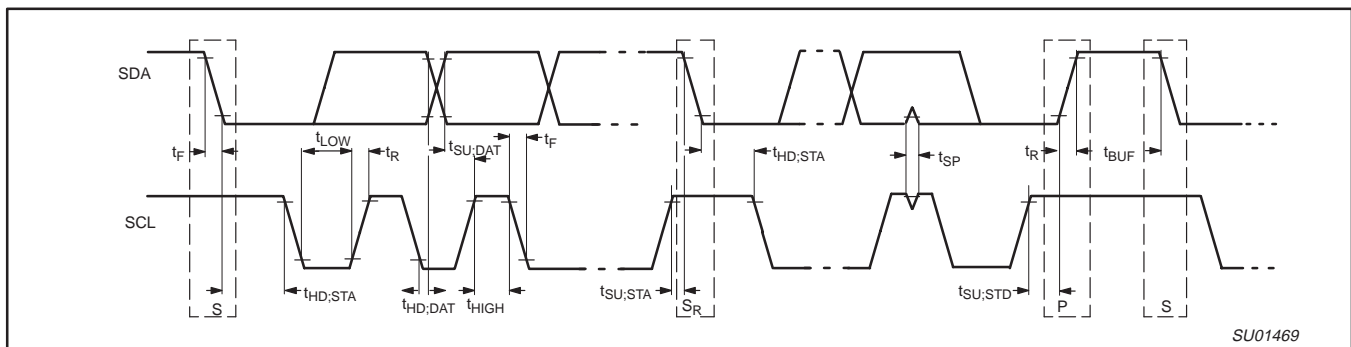

Figure 14. Definition of timing

SU01469

16-bit I²C and SMBus, low power I/O port with interrupt

PCA9539

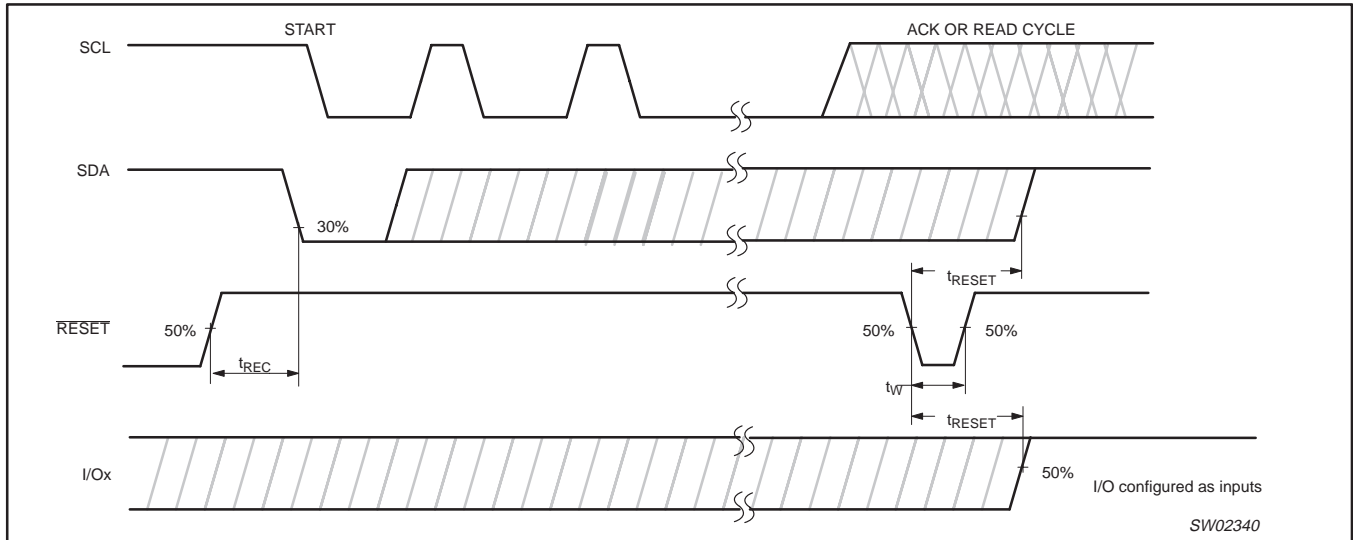

Figure 15. Definition of RESET timing

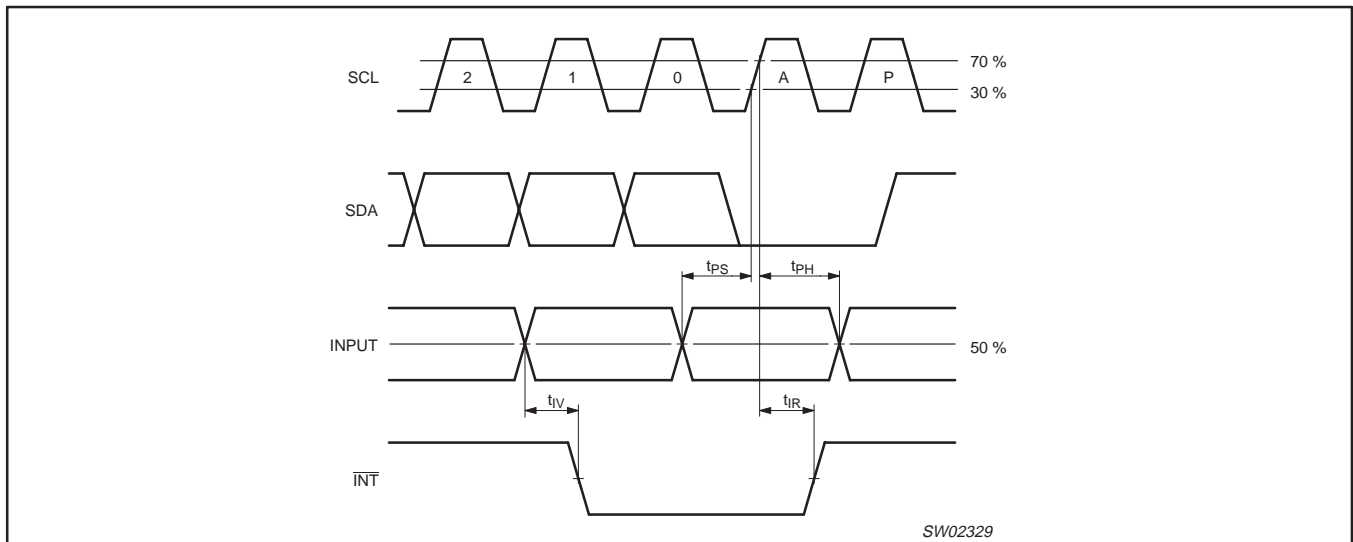

Figure 16. Expanded view of Read input port register

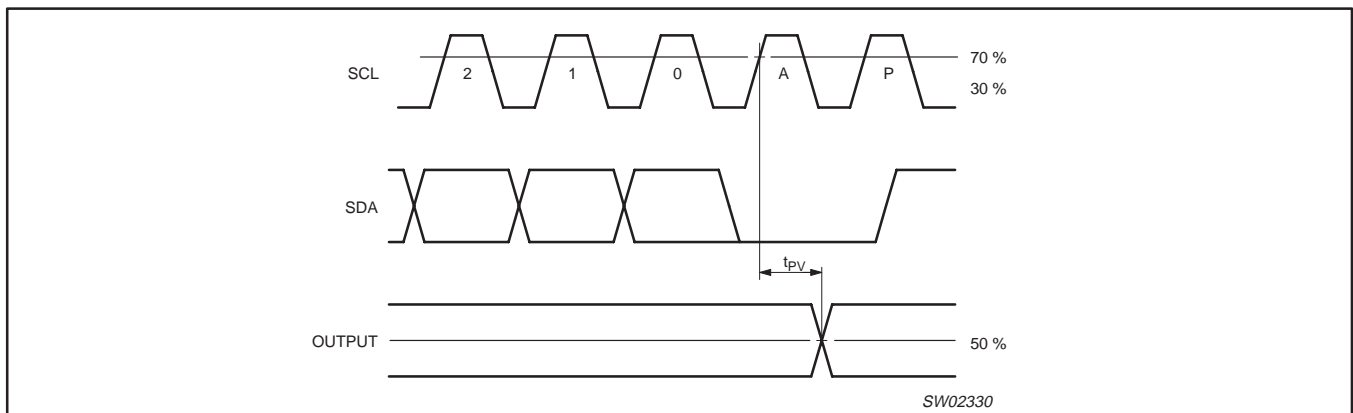

Figure 17. Expanded view of Write to output port register

16-bit I²C and SMBus, low power I/O port with interrupt

PCA9539

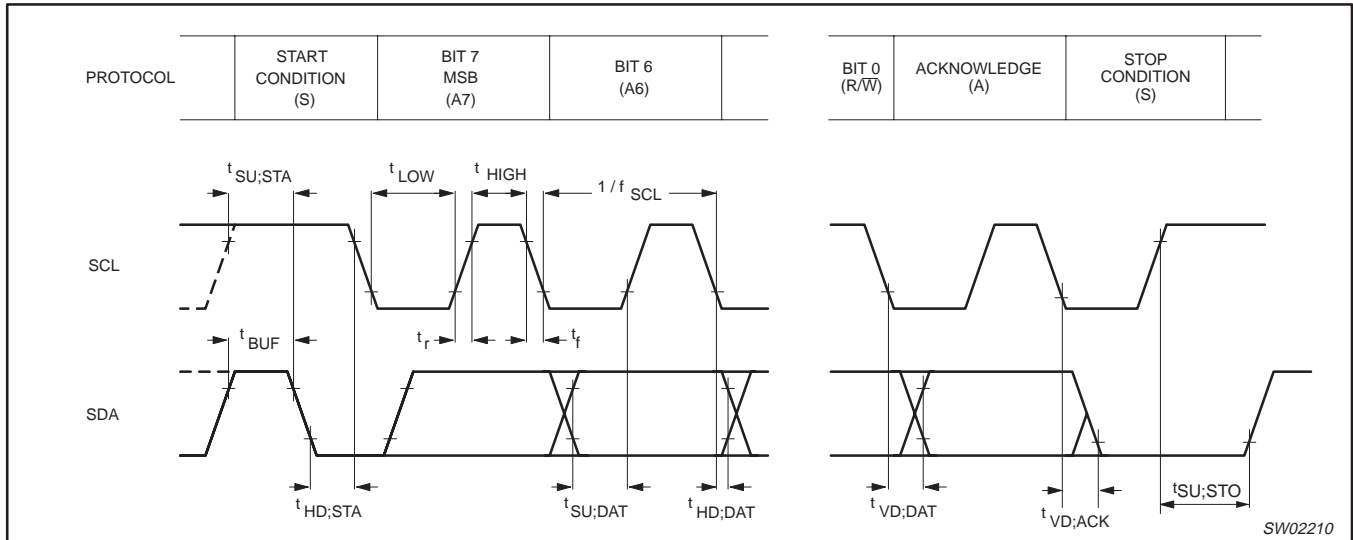

Figure 18. I²C-bus timing diagram; rise and fall times refer to V_{IL} and V_{IH}

TEST CIRCUITS

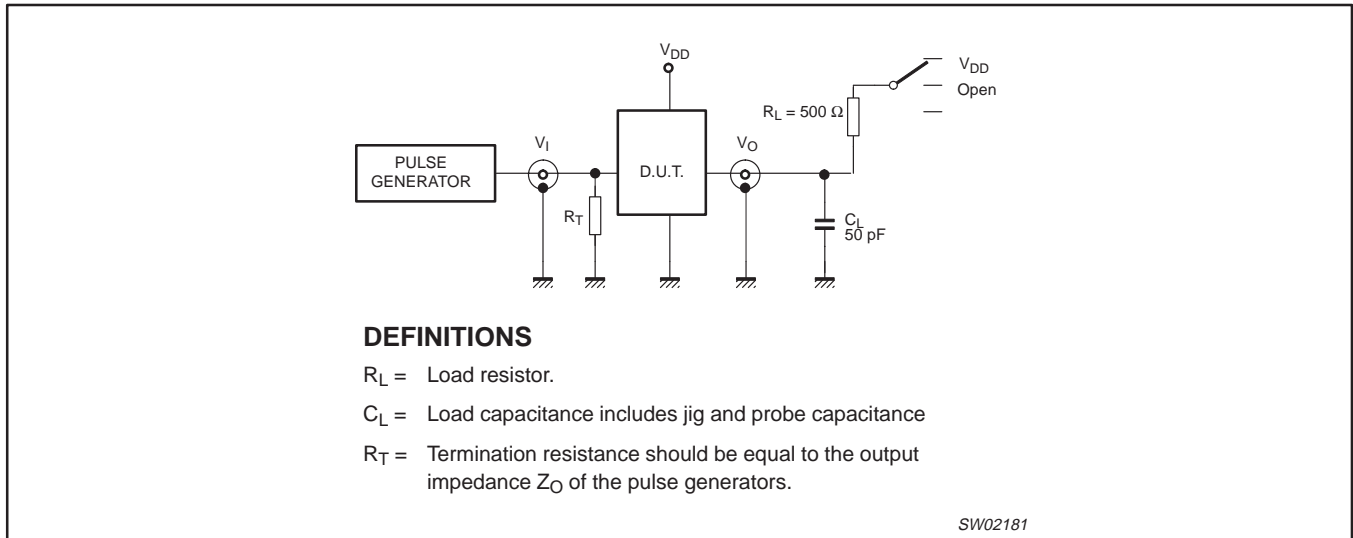

Figure 19. Test circuitry for switching times

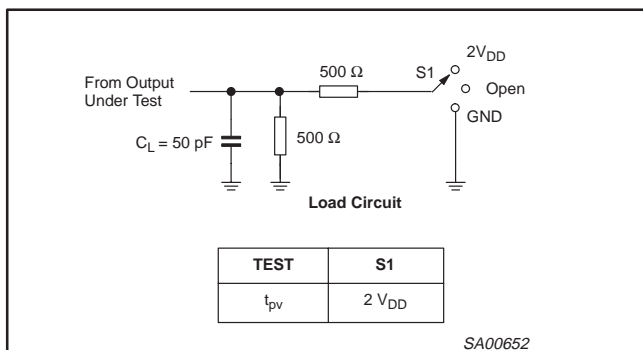

Figure 20. Test circuit

16-bit I²C and SMBus, low power I/O port with interrupt

PCA9539

SO24: plastic small outline package; 24 leads; body width 7.5 mm

SOT137-1

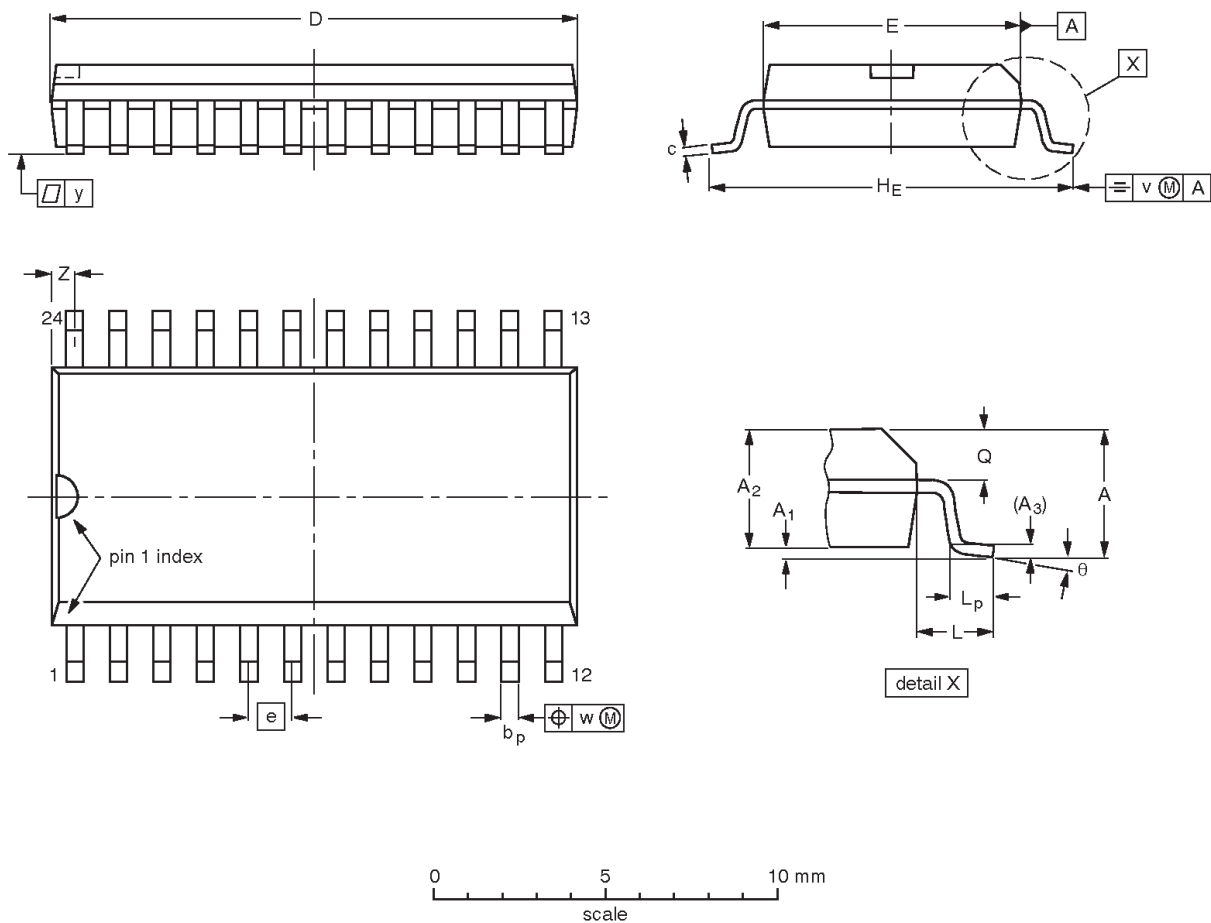

DIMENSIONS (inch dimensions are derived from the original mm dimensions)

UNIT	A max.	A ₁	A ₂	A ₃	b _p	c	D ⁽¹⁾	E ⁽¹⁾	e	HE	L	L _p	Q	v	w	y	Z ⁽¹⁾	θ
mm	2.65	0.3 0.1	2.45 2.25	0.25	0.49 0.36	0.32 0.23	15.6 15.2	7.6 7.4	1.27	10.65 10.00	1.4	1.1 0.4	1.1 1.0	0.25	0.25	0.1	0.9 0.4	8° 0°
inches	0.1	0.012 0.004	0.096 0.089	0.01	0.019 0.014	0.013 0.009	0.61 0.60	0.30 0.29	0.05	0.419 0.394	0.055	0.043 0.016	0.043 0.039	0.01	0.01	0.004	0.035 0.016	

Note

1. Plastic or metal protrusions of 0.15 mm (0.006 inch) maximum per side are not included.

OUTLINE VERSION	REFERENCES				EUROPEAN PROJECTION	ISSUE DATE
	IEC	JEDEC	JEITA			
SOT137-1	075E05	MS-013				99-12-27 03-02-19

16-bit I²C and SMBus, low power I/O port with interrupt

PCA9539

TSSOP24: plastic thin shrink small outline package; 24 leads; body width 4.4 mm

SOT355-1

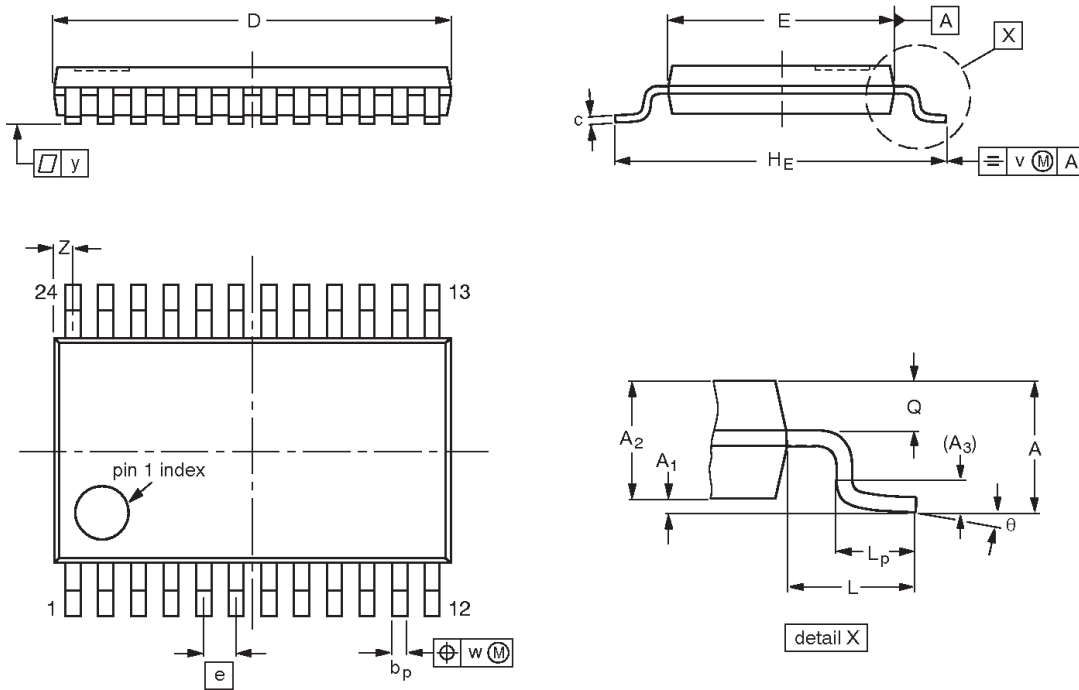

DIMENSIONS (mm are the original dimensions)

UNIT	A max.	A ₁	A ₂	A ₃	b _p	c	D ⁽¹⁾	E ⁽²⁾	e	H _E	L	L _p	Q	v	w	y	Z ⁽¹⁾	θ
mm	1.1	0.15 0.05	0.95 0.80	0.25	0.30 0.19	0.2 0.1	7.9 7.7	4.5 4.3	0.65	6.6 6.2	1	0.75 0.50	0.4 0.3	0.2	0.13	0.1	0.5 0.2	8° 0°

Notes

1. Plastic or metal protrusions of 0.15 mm maximum per side are not included.
2. Plastic interlead protrusions of 0.25 mm maximum per side are not included.

OUTLINE VERSION	REFERENCES				EUROPEAN PROJECTION	ISSUE DATE
	IEC	JEDEC	JEITA			
SOT355-1		MO-153				99-12-27 03-02-19

16-bit I²C and SMBus, low power I/O port with interrupt

PCA9539

HVQFN24: plastic thermal enhanced very thin quad flat package; no leads; 24 terminals;
body 4 x 4 x 0.85 mm

SOT616-1

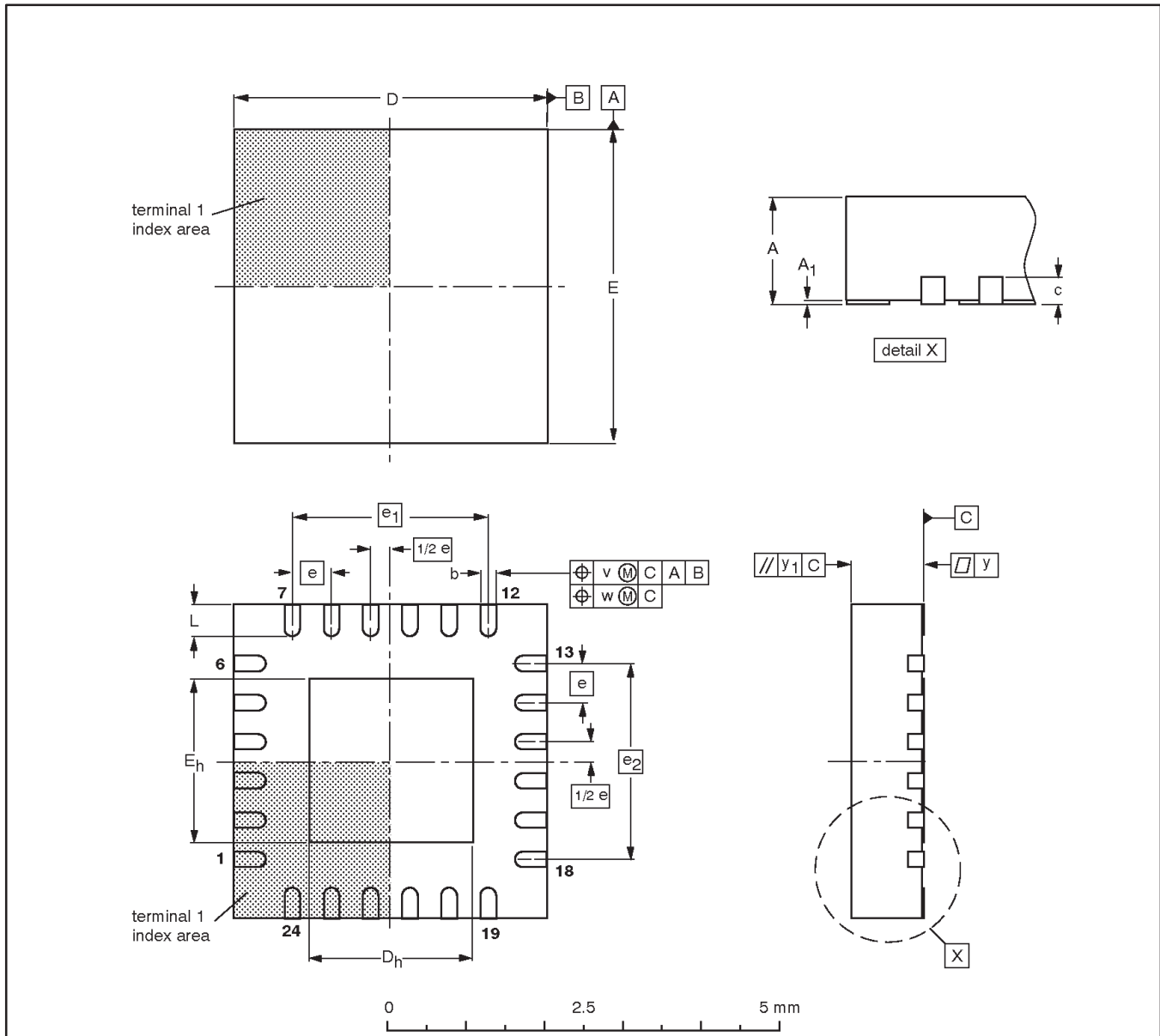

DIMENSIONS (mm are the original dimensions)

UNIT	A ⁽¹⁾ max.	A ₁	b	c	D ⁽¹⁾	D _h	E ⁽¹⁾	E _h	e	e ₁	e ₂	L	v	w	y	y ₁
mm	1	0.05 0.00	0.30 0.18	0.2	4.1 3.9	2.25 1.95	4.1 3.9	2.25 1.95	0.5	2.5	2.5	0.5 0.3	0.1	0.05	0.05	0.1

Note

1. Plastic or metal protrusions of 0.075 mm maximum per side are not included.

OUTLINE VERSION	REFERENCES				EUROPEAN PROJECTION	ISSUE DATE
	IEC	JEDEC	JEITA			
SOT616-1	---	MO-220	---			01-08-08 02-10-22

16-bit I²C and SMBus, low power I/O port with interrupt

PCA9539

REVISION HISTORY

Rev	Date	Description
2	20040930	Product data sheet (9397 750 14048). Supersedes data of 2004 Aug 27 (9397 750 12898). Modifications: <ul style="list-style-type: none">● Section "Registers 0 and 1—Input Port Registers" on page 6:<ul style="list-style-type: none">– add table and second paragraph● Figure 11 on page 11: resistor values modified● "DC Characteristics" table on page 13:<ul style="list-style-type: none">– sub-section "I/Os":<ul style="list-style-type: none">change V{IL} (max) from 0.8 V to $0.3V_{DD}$change V_{IH} (min) from 2.0 V to $0.7V_{DD}$– sub-section "Select inputs A0, A1, and RESET":<ul style="list-style-type: none">change V_{IL} (max) from 0.8 V to $0.3V_{DD}$change V_{IH} (min) from 2.0 V to $0.7V_{DD}$● Figure 15 on page 15 modified.
_1	20040827	Product data sheet (9397 750 12898).

16-bit I²C and SMBus, low power I/O port with interrupt

PCA9539



Purchase of Philips I²C components conveys a license under the Philips' I²C patent to use the components in the I²C system provided the system conforms to the I²C specifications defined by Philips. This specification can be ordered using the code 9398 393 40011.

Data sheet status

Level	Data sheet status [1]	Product status [2] [3]	Definitions
I	Objective data sheet	Development	This data sheet contains data from the objective specification for product development. Philips Semiconductors reserves the right to change the specification in any manner without notice.
II	Preliminary data sheet	Qualification	This data sheet contains data from the preliminary specification. Supplementary data will be published at a later date. Philips Semiconductors reserves the right to change the specification without notice, in order to improve the design and supply the best possible product.
III	Product data sheet	Production	This data sheet contains data from the product specification. Philips Semiconductors reserves the right to make changes at any time in order to improve the design, manufacturing and supply. Relevant changes will be communicated via a Customer Product/Process Change Notification (CPCN).

[1] Please consult the most recently issued data sheet before initiating or completing a design.

[2] The product status of the device(s) described in this data sheet may have changed since this data sheet was published. The latest information is available on the Internet at URL <http://www.semiconductors.philips.com>.

[3] For data sheets describing multiple type numbers, the highest-level product status determines the data sheet status.

Definitions

Short-form specification — The data in a short-form specification is extracted from a full data sheet with the same type number and title. For detailed information see the relevant data sheet or data handbook.

Limiting values definition — Limiting values given are in accordance with the Absolute Maximum Rating System (IEC 60134). Stress above one or more of the limiting values may cause permanent damage to the device. These are stress ratings only and operation of the device at these or at any other conditions above those given in the Characteristics sections of the specification is not implied. Exposure to limiting values for extended periods may affect device reliability.

Application information — Applications that are described herein for any of these products are for illustrative purposes only. Philips Semiconductors make no representation or warranty that such applications will be suitable for the specified use without further testing or modification.

Disclaimers

Life support — These products are not designed for use in life support appliances, devices, or systems where malfunction of these products can reasonably be expected to result in personal injury. Philips Semiconductors customers using or selling these products for use in such applications do so at their own risk and agree to fully indemnify Philips Semiconductors for any damages resulting from such application.

Right to make changes — Philips Semiconductors reserves the right to make changes in the products—including circuits, standard cells, and/or software—described or contained herein in order to improve design and/or performance. When the product is in full production (status 'Production'), relevant changes will be communicated via a Customer Product/Process Change Notification (CPCN). Philips Semiconductors assumes no responsibility or liability for the use of any of these products, conveys no license or title under any patent, copyright, or mask work right to these products, and makes no representations or warranties that these products are free from patent, copyright, or mask work right infringement, unless otherwise specified.

Contact information

For additional information please visit
<http://www.semiconductors.philips.com>. Fax: +31 40 27 24825

© Koninklijke Philips Electronics N.V. 2004
 All rights reserved. Printed in U.S.A.

For sales offices addresses send e-mail to:
sales.addresses@www.semiconductors.philips.com

Date of release: 09-04
 Document order number: 9397 750 14048

Let's make things better.