	= Preliminary =	AK4366
Low Power 24-Bit 2ch DAC with HP-AMP		

GENERAL DESCRIPTION

The AK4366 is 24bit DAC with built-in Headphone Amplifier. The integrated headphone amplifier features “click-free” power-on/off, a mute control and delivers 50mW of power at 16Ω. The AK4366 is housed in a 16pin TSSOP package, making it suitable for portable applications.

FEATURE

- Multi-bit $\Delta\Sigma$ DAC
- Sampling Rate: 8kHz-48kHz
- 64x Oversampling
- On chip perfect filtering 8 times FIR interpolator
 - Passband: 20kHz
 - Passband Ripple: $\pm 0.02\text{dB}$
 - Stopband Attenuation: 54dB
- Digital De-emphasis Filter: 32kHz, 44.1kHz and 48kHz
- System Clock: 256fs/384fs/512fs
 - Input Level: CMOS or 0.4Vpp Analog Input
- Audio I/F Format: MSB First, 2's Complement
 - I²S, 24bit MSB justified, 24bit/20bit/16bit LSB justified
- μP Interface: 3-wire
- Bass Boost Function
- Headphone Amplifier
 - Output Power: 50mW x 2ch @16Ω, 3.3V
 - S/N: 92dB@2.4V
 - Click Noise Free at Power-ON/OFF and Mute
- Power Supply: 2.2V ~ 3.6V
- Power Supply Current: 2.6mA@2.4V (@HP-AMP no-input)
- Ta: -40 ~ 85°C
- Small Package: 16pin TSSOP

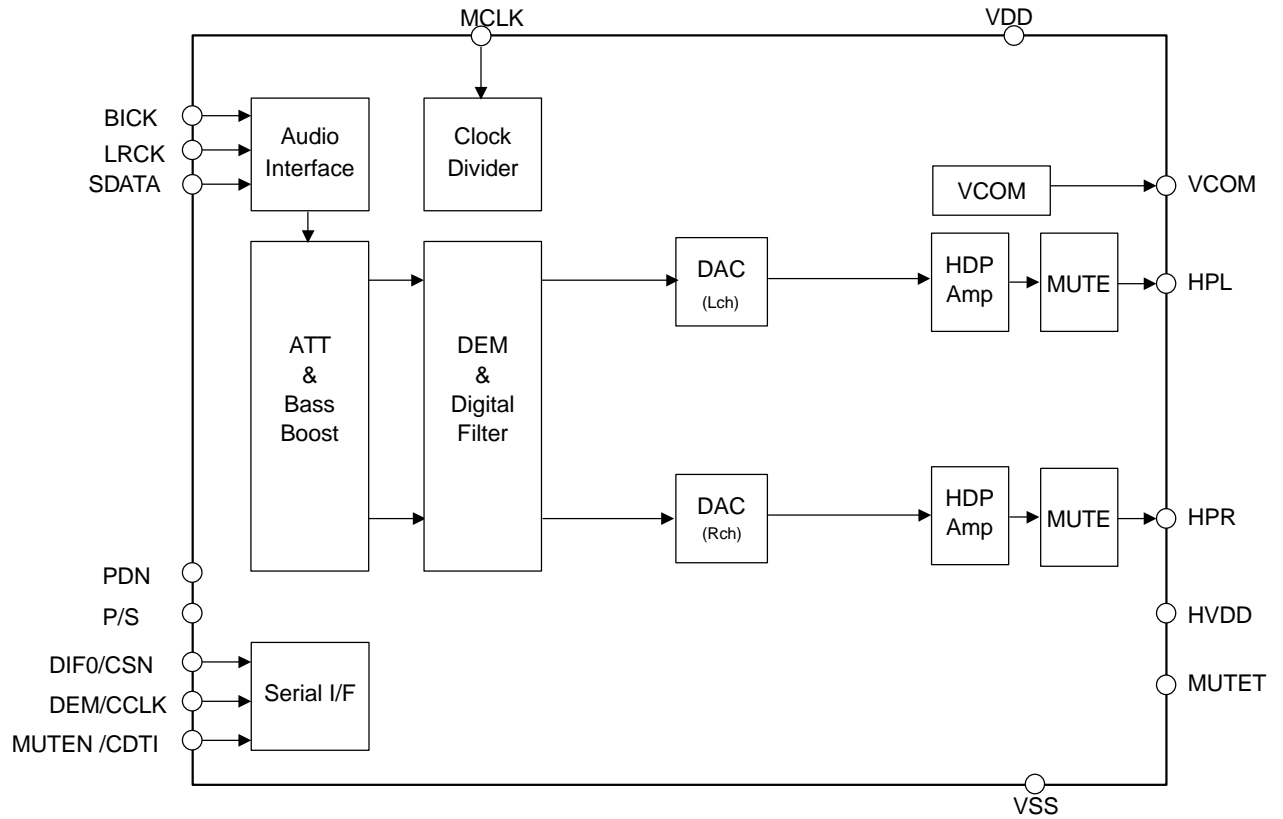
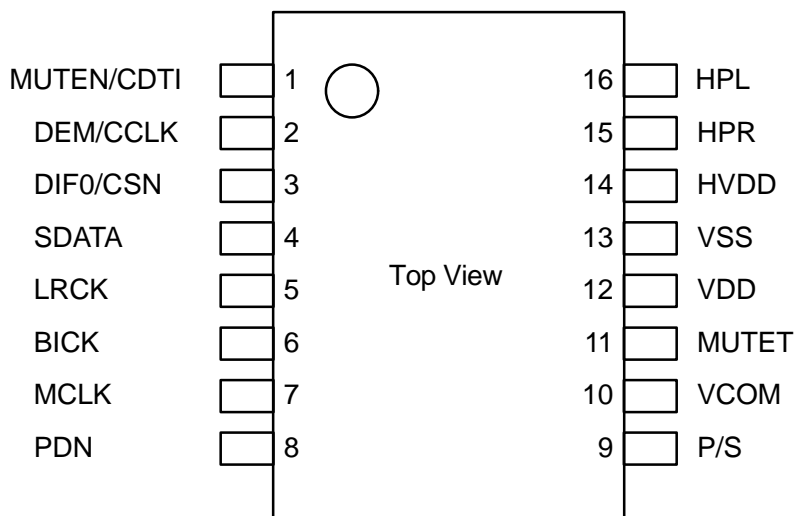

Figure 1. AK4366 Block Diagram

■ **Ordering Guide**

AK4366VT	-40 ~ +85°C	16pin TSSOP (0.65mm pitch)
AKD4366	Evaluation board for AK4366	

■ **Pin Layout**



PIN/FUNCTION			
No.	Pin Name	I/O	Function
1	MUTEN	I	Headphone Amp Mute Pin (P/S= "H") "H": Normal operation, "L": Mute
	CDTI	I	Control Data Input Pin (P/S= "L")
2	DEM	I	De-emphasis Pin (P/S= "H") "H": ON(44.1kHz), "L": OFF
	CCLK	I	Control Data Clock Pin (P/S= "L")
3	DIF0	I	Audio Interface Format Pin (P/S= "H") "H": I ² S, "L": 24bit MSB justified
	CSN	I	Control Data Chip Select Pin (P/S= "L")
4	SDATA	I	Audio Serial Data Input Pin
5	LRCK	I	L/R Clock Pin This clock determines which audio channel is currently being input on SDATA pin.
6	BICK	I	Serial Bit Clock Pin This clock is used to latch audio data.
7	MCLK	I	Master Clock Input Pin
8	PDN	I	Power-down & Reset Pin When at "L", the AK4366 is in power-down mode and is held in reset. The AK4366 should always be reset upon power-up.
9	P/S	I	Control Mode Select Pin (Internal Pull-down Pin) "H": Parallel, "L": 3-wire Serial
10	VCOM	O	Common Voltage Output Pin Normally connected to VSS pin with 0.1μF ceramic capacitor in parallel with a 2.2μF electrolytic capacitor.
11	MUTET	O	Mute Time Constant Control Pin Connected to VSS pin with a capacitor for mute time constant.
12	VDD	-	Power Supply Pin
13	VSS	-	Ground Pin
14	HVDD	-	Power Supply Pin for Headphone Amp
15	HPR	O	Rch Headphone Amp Output Pin
16	HPL	O	Lch Headphone Amp Output Pin

Note: All digital input pins except internal pull-down pin must not be left floating.

ABSOLUTE MAXIMUM RATING

(VSS=0V; Note 1)

Parameter		Symbol	min	max	Units
Power Supplies	Analog, Digital	VDD	-0.3	4.6	V
	HP-AMP	HVDD	-0.3	4.6	V
Input Current (any pins except for supplies)		IIN	-	±10	mA
Input Voltage		VIN	-0.3	VDD+0.3 or 4.6	V
Ambient Temperature		Ta	-40	85	°C
Storage Temperature		Tstg	-65	150	°C

Note 1. All voltages with respect to ground.

WARNING: Operation at or beyond these limits may result in permanent damage to the device.

Normal operation is not guaranteed at these extremes.

RECOMMEND OPERATING CONDITIONS

(VSS=0V; Note 1)

Parameter		Symbol	min	typ	max	Units
Power Supplies (Note 2)	Analog, Digital	VDD	2.2	2.4	3.6	V
	HP-AMP	HVDD	2.2	2.4	3.6	V

Note 1. All voltages with respect to ground.

Note 2. VDD should be same voltage as HVDD.

* AKM assumes no responsibility for usage beyond the conditions in this datasheet.

ANALOG CHARACTERISTICS

(Ta=25°C; VDD=HVDD=2.4V, VSS=0V; fs=44.1kHz; BOOST OFF; Signal Frequency =1kHz; Measurement band width=10Hz ~ 20kHz; Load impedance is a serial connection with $R_L=16\Omega$ and $C_L=220\mu F$. (Refer to Figure 19); unless otherwise specified)

Parameter	min	typ	max	Units	
DAC Resolution	-	-	24	bit	
Headphone-Amp: (HPL/HPR pins) (Note 3)					
Analog Output Characteristics					
THD+N	(-3dBFS Output, Po=15mW@16Ω, 2.4V)	-	-58	TBD	dB
	(-3dBFS Output, Po=28mW@16Ω, 3.3V)	-	-58	-	dB
D-Range	(-60dBFS Output, A-weighted, 2.4V)	TBD	92	-	dB
	(-60dBFS Output, A-weighted, 3.3V)	-	94	-	dB
S/N	(A-weighted, 2.4V)	TBD	92	-	dB
	(A-weighted, 3.3V)	-	94	-	dB
Interchannel Isolation		TBD	80	-	dB
DC Accuracy					
Interchannel Gain Mismatch		-	0.2	TBD	dB
Gain Drift		-	200	-	ppm/°C
Load Resistance	(Note 4)	16	-	-	Ω
Load Capacitance		-	-	300	pF
Output Voltage	(-3dBFS Output) (Note 5)	TBD	1.39	TBD	Vpp
Max Output Power	($R_L=16\Omega$, 2.4V)	-	26	-	mW
	($R_L=16\Omega$, 3.3V)	-	50	-	mW
Power Supplies					
Power Supply Current					
Normal Operation (PDN= "H")	(Note 6)				
VDD		-	1.6	TBD	mA
HVDD		-	1.0	TBD	mA
Power-Down Mode (PDN= "L")	(Note 7)	-	1	TBD	μA

Note 3. DACL=DACR= "1", ATTL=ATTR=0dB.

Note 4. AC Load

Note 5. Output voltage is proportional to VDD voltage. $V_{out} = 0.58 \times VDD(\text{typ})@-3\text{dBFS}$.

Note 6. PMDAC=PMHPL=PMHPR= "1", MUTEN= "1" and HP-Amp output is off.

Note 7. All digital input pins including clock pins (MCLK, BICK and LRCK) are held at DVDD or DVSS. PDN pin is held at VSS.

FILTER CHARACTERISTICS							
(Ta=25°C; VDD, HVDD=2.2 ~ 3.6V; fs=44.1kHz; De-emphasis = "OFF")							
Parameter		Symbol	min	typ	max	Units	
DAC Digital Filter: (Note 8)							
Passband	-0.05dB	PB	0	-	20.0	kHz	
	-6.0dB			22.05		kHz	
Stopband		SB	24.1	-	-	kHz	
Passband Ripple		PR	-	-	±0.02	dB	
Stopband Attenuation		SA	54	-	-	dB	
Group Delay		GD	-	20.8	-	1/fs	
Group Delay Distortion		ΔGD	-	0	-	μs	
DAC Digital Filter + Analog Filter: (Note 8) (Note 11)							
Frequency Response	0 ~ 20.0kHz	FR	-	±0.5	-	dB	
BOOST Filter: (Note 11) (Note 12)							
Frequency Response	MIN	20Hz	FR	-	5.76	-	dB
		100Hz		-	2.92	-	dB
		1kHz		-	0.02	-	dB
	MID	20Hz	FR	-	10.80	-	dB
		100Hz		-	6.84	-	dB
		1kHz		-	0.13	-	dB
	MAX	20Hz	FR	-	16.06	-	dB
		100Hz		-	10.54	-	dB
		1kHz		-	0.37	-	dB

Note 8. BOOST OFF (BST1-0 = "00")

Note 9. The passband and stopband frequencies scale with fs.

For example, PB=0.4535*fs(@±0.05dB), SB=0.546*fs(@-54dB).

Note 10. This is the calculated delay time caused by digital filtering. This time is measured from the setting of the 24bit data of both channels to the input registers to the output of the analog signal.

Note 11. DAC → HPL, HPR

Note 12. These frequency responses scale with fs. If high-level signal is input, the AK4366 clips at low frequency.

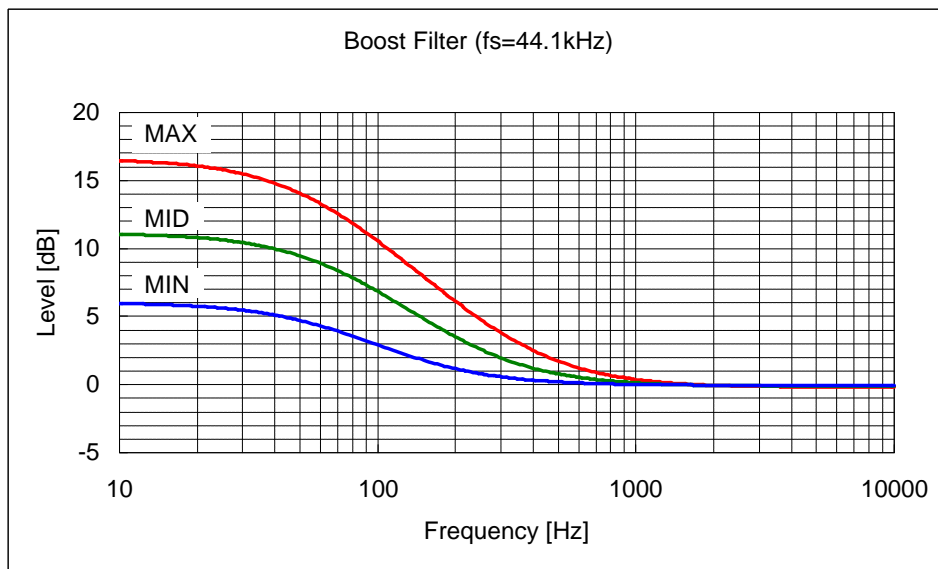

Figure 2. Boost Frequency (fs=44.1kHz)

DC CHARACTERISTICS

(Ta=25°C; VDD, HVDD=2.2 ~ 3.6V)

Parameter	Symbol	min	typ	max	Units
High-Level Input Voltage	VIH	70%DVDD	-	-	V
Low-Level Input Voltage	VIL	-	-	30%DVDD	V
Input Voltage at AC Coupling (Note 13)	VAC	0.4	-	-	Vpp
Input Leakage Current (Note 14)	Iin	-	-	±10	μA

Note 13. Only MCLK pin. (Figure 19)

Note 14. P/S pin has internal pull-down device, nominally 100kΩ.

SWITCHING CHARACTERISTICS

(Ta=25°C; VDD, HVDD=2.2 ~ 3.6V; CL = 20pF)

Parameter	Symbol	min	typ	max	Units
Master Clock Timing					
Frequency	fCLK	2.048	-	24.576	MHz
Pulse Width Low (Note 15)	tCLKL	0.4/fCLK	-	-	ns
Pulse Width High (Note 15)	tCLKH	0.4/fCLK	-	-	ns
AC Pulse Width (Note 18)	tACW	20	-	-	ns
LRCK Timing					
Frequency	fs	8	44.1	48	kHz
Duty Cycle:	Duty	45	-	55	%
Serial Interface Timing (Note 16)					
BICK Period	tBCK	1/(64fs)	-	-	ns
BICK Pulse Width Low	tBCKL	130	-	-	ns
Pulse Width High	tBCKH	130	-	-	ns
LRCK Edge to BICK “↑” (Note 17)	tLRB	50	-	-	ns
BICK “↑” to LRCK Edge (Note 17)	tBLR	50	-	-	ns
SDATA Hold Time	tSDH	50	-	-	ns
SDATA Setup Time	tSDS	50	-	-	ns
Control Interface Timing					
CCLK Period	tCCK	200	-	-	ns
CCLK Pulse Width Low	tCCKL	80	-	-	ns
Pulse Width High	tCCKH	80	-	-	ns
CDTI Setup Time	tCDS	40	-	-	ns
CDTI Hold Time	tCDH	40	-	-	ns
CSN “H” Time	tCSW	150	-	-	ns
CSN “↑” to CCLK “↑”	tCSS	50	-	-	ns
CCLK “↑” to CS “↑”	tCSH	50	-	-	ns

Note 15. Except AC coupling.

Note 16. Refer to “Serial Data Interface”.

Note 17. BICK rising edge must not occur at the same time as LRCK edge.

Note 18. Pulse width to ground level when MCLK is connected to a capacitor in series and a resistor is connected to ground.

(Refer to Figure 3.)

■ Timing Diagram

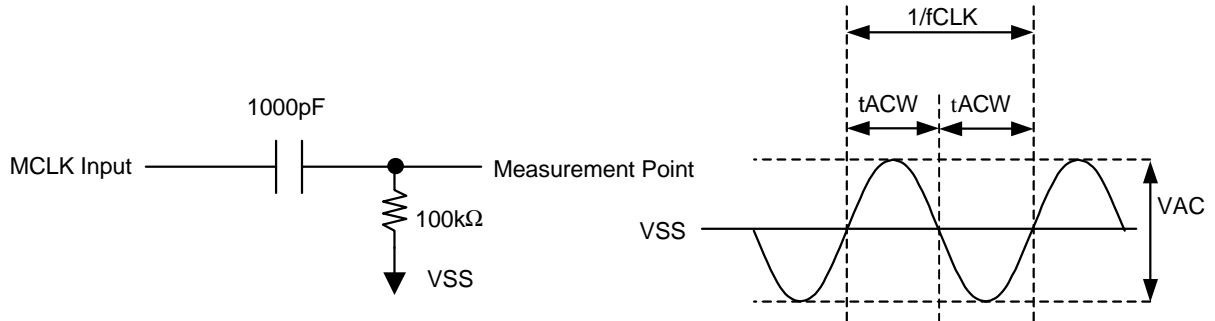

Figure 3. MCLK AC Coupling Timing

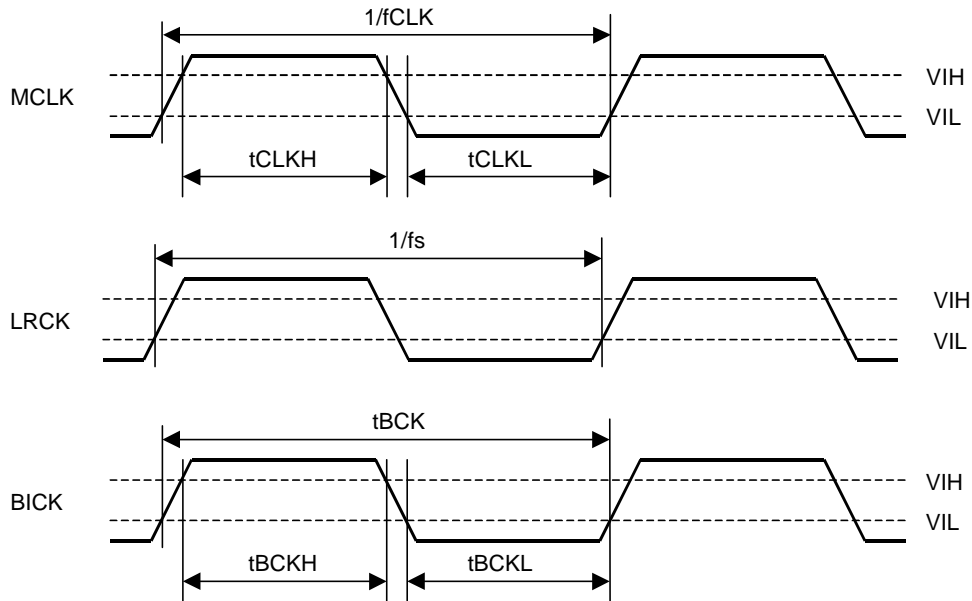

Figure 4. Clock Timing

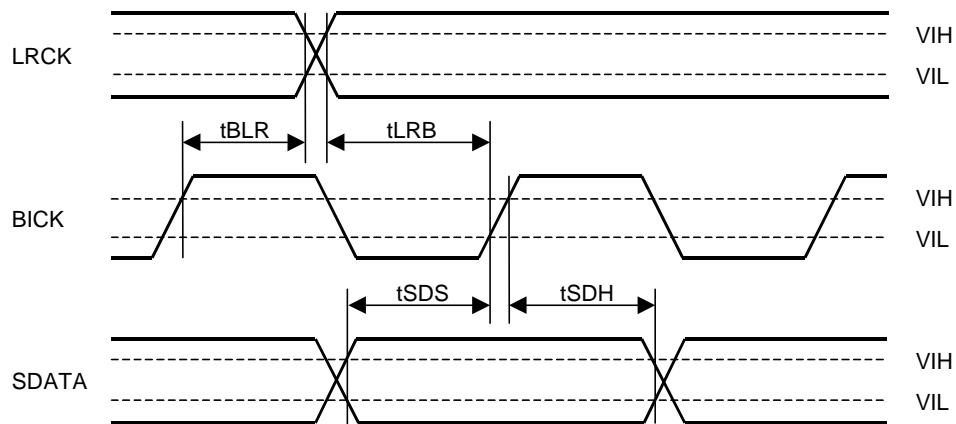

Figure 5. Serial Interface Timing

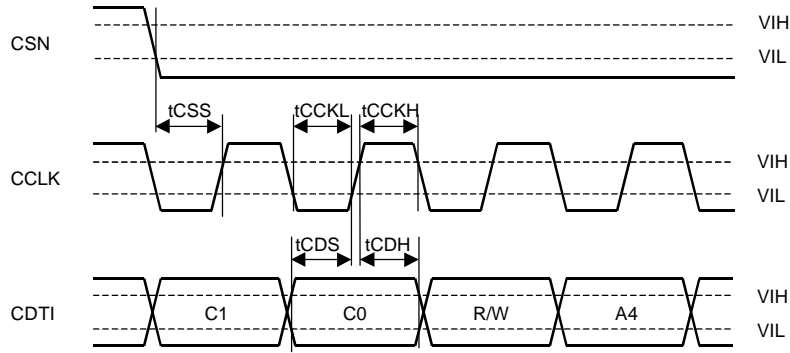

Figure 6. WRITE Command Input Timing

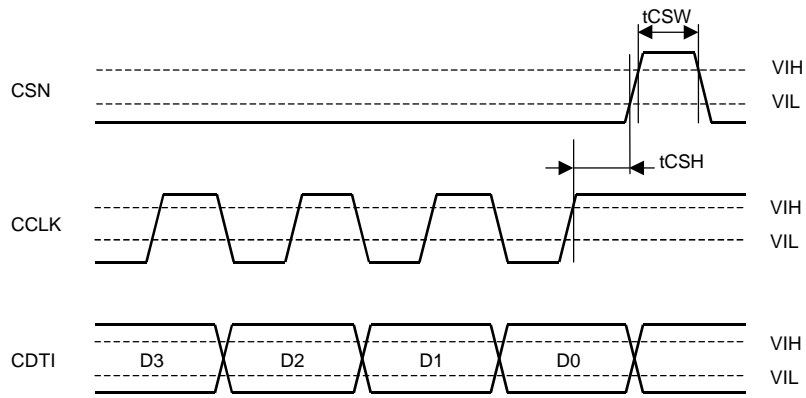

Figure 7. WRITE Data Input Timing

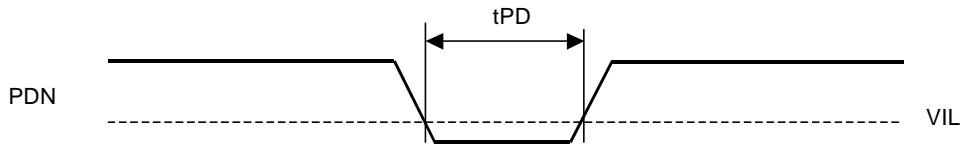

Figure 8. Power-down & Reset Timing

OPERATION OVERVIEW

■ System Clock

The external clocks required to operate the AK4366 are MCLK(256fs/384fs/512fs), LRCK(fs) and BICK. The master clock (MCLK) should be synchronized with sampling clock (LRCK). The phase between these clocks does not matter. The frequency of MCLK is detected automatically, and the internal master clock becomes the appropriate frequency. Table 1 shows system clock example.

In serial mode (P/S= "L"), when the sampling frequency is changed during normal operation (PMDAC= "1"), the DAC output should be soft-muted or "0" data should be input to avoid click noise.

In parallel mode (P/S= "H"), when the sampling frequency is changed during normal operation (PDN= "H"), the DAC output should be soft-muted or "0" data should be input to avoid click noise.

LRCK	MCLK (MHz)			BICK (MHz)
	fs	256fs	384fs	
8kHz	2.048	3.072	4.096	0.512
11.025kHz	2.8224	4.2336	5.6448	0.7056
12kHz	3.072	4.608	6.144	0.768
16kHz	4.096	6.144	8.192	1.024
22.05kHz	5.6448	8.4672	11.2896	1.4112
24kHz	6.144	9.216	12.288	1.536
32kHz	8.192	12.288	16.384	2.048
44.1kHz	11.2896	16.9344	22.5792	2.8224
48kHz	12.288	18.432	24.576	3.072

Table 1. System Clock Example

In serial mode (P/S= "L"), all external clocks (MCLK, BICK and LRCK) should always be present whenever the DAC is in normal operation mode (PMDAC bit = "1"). If these clocks are not provided, the AK4366 may draw excess current and will not operate properly because it utilizes these clocks for internal dynamic refresh of registers. If the external clocks are not present, the DAC should be placed in power-down mode (PMDAC bit = "0"). When MCLK is input with AC coupling, the MCKAC bit should be set to "1".

In parallel mode (P/S= "H"), all external clocks (MCLK, BICK and LRCK) should always be present whenever the DAC is in normal operation mode (PDN pin = "H"). If these clocks are not provided, the AK4366 may draw excess current and will not operate properly because it utilizes these clocks for internal dynamic refresh of registers. If the external clocks are not present, the DAC should be placed in power-down mode (PDN pin = "L").

For low sampling rates, DR and S/N degrade because of the outband noise. In serial mode (P/S= "L"), DR and S/N are improved by setting DFS1 bit to "1". Table 2 shows S/N of HP-amp output. When the DFS1 bit is "1", MCLK needs 512fs.

DFS1	DFS0	Over Sample Rate	fs	MCLK	S/N (fs=8kHz, A-weighted)
					HP-amp
0	0	64fs	8kHz~48kHz	256fs/384fs/512fs	56dB
0	1	128fs	8kHz~24kHz	256fs/384fs/512fs	75dB
1	x	256fs	8kHz~12kHz	512fs	92dB

Default

Table 2. Relationship among fs, MCLK frequency and S/N of HP-amp

■ Serial Data Interface

The AK4366 interfaces with external system via the SDATA, BICK and LRCK pins. In serial mode (P/S= “L”), five data formats are available and are selected by setting DIF2, DIF1 and DIF0 bits (Table 3). In parallel mode (P/S= “H”), two data formats are available and are selected by setting DIF0 pin (Table 3). Mode 0 is compatible with existing 16bit DACs and digital filters. Mode 1 is a 20bit version of Mode 0. Mode 4 is a 24bit version of Mode 0. Mode 2 is similar to AKM ADCs and many DSP serial ports. Mode 3 is compatible with the I²S serial data protocol. In Modes 2 and 3 with BICK≥48fs, the following formats are also valid: 16-bit data followed by eight zeros (17th to 24th bits) and 20-bit data followed by four zeros (21st to 24th bits). In all modes, the serial data is MSB first and 2’s complement format.

DIF2 bit	DIF1 bit	DIF0 bit	MODE	BICK	Figure
0	0	0	0: 16bit, LSB justified	32fs ≤ BICK ≤ 64fs	Figure 9
0	0	1	1: 20bit, LSB justified	40fs ≤ BICK ≤ 64fs	Figure 10
0	1	0	2: 24bit, MSB justified	48fs ≤ BICK ≤ 64fs	Figure 11
0	1	1	3: I ² S Compatible	BICK=32fs or 48fs ≤ BICK ≤ 64fs	Figure 12
1	0	0	4: 24bit, LSB justified	48fs ≤ BICK ≤ 64fs	Figure 10

Table 3. Audio Data Format (Serial Mode)

DIF0 pin	MODE	BICK	Figure
L	2: 24bit, MSB justified	48fs ≤ BICK ≤ 64fs	Figure 11
H	3: I ² S Compatible	BICK=32fs or 48fs ≤ BICK ≤ 64fs	Figure 12

Table 4. Audio Data Format (Parallel Mode)

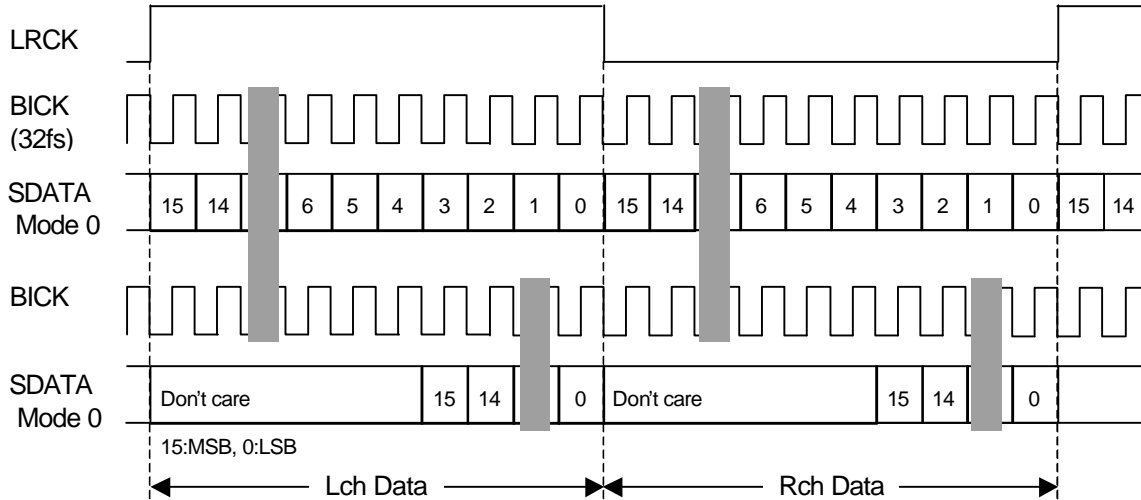

Figure 9. Mode 0 Timing

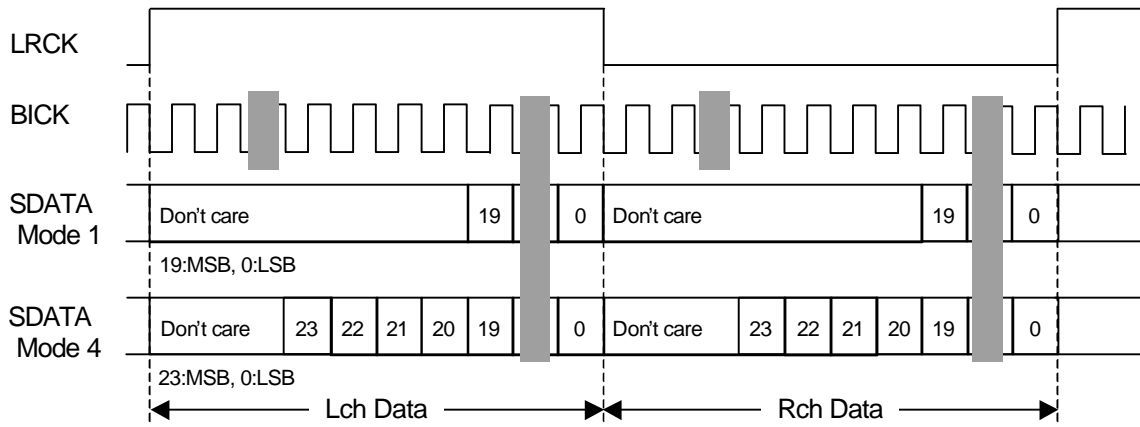

Figure 10. Mode 1, 4 Timing

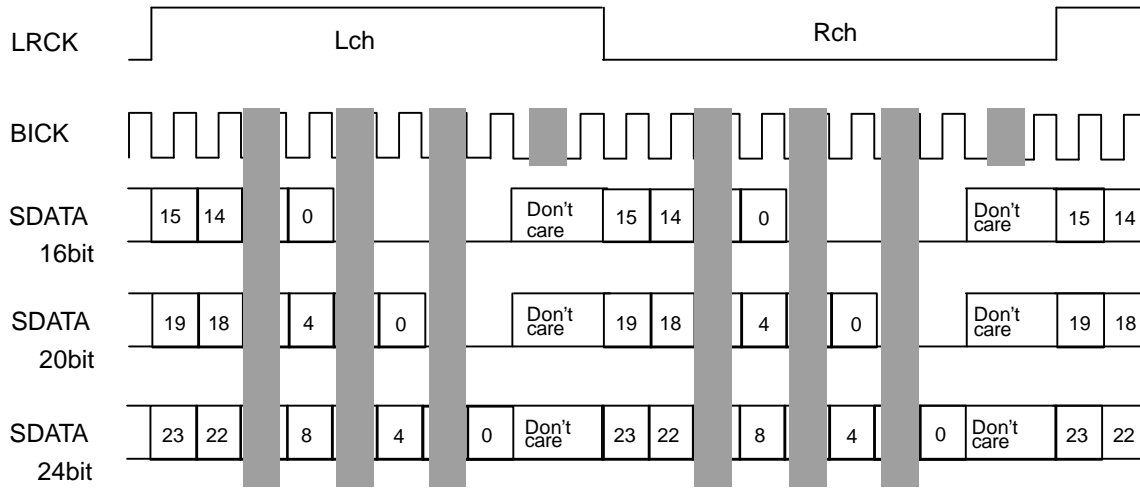

Figure 11. Mode 2 Timing

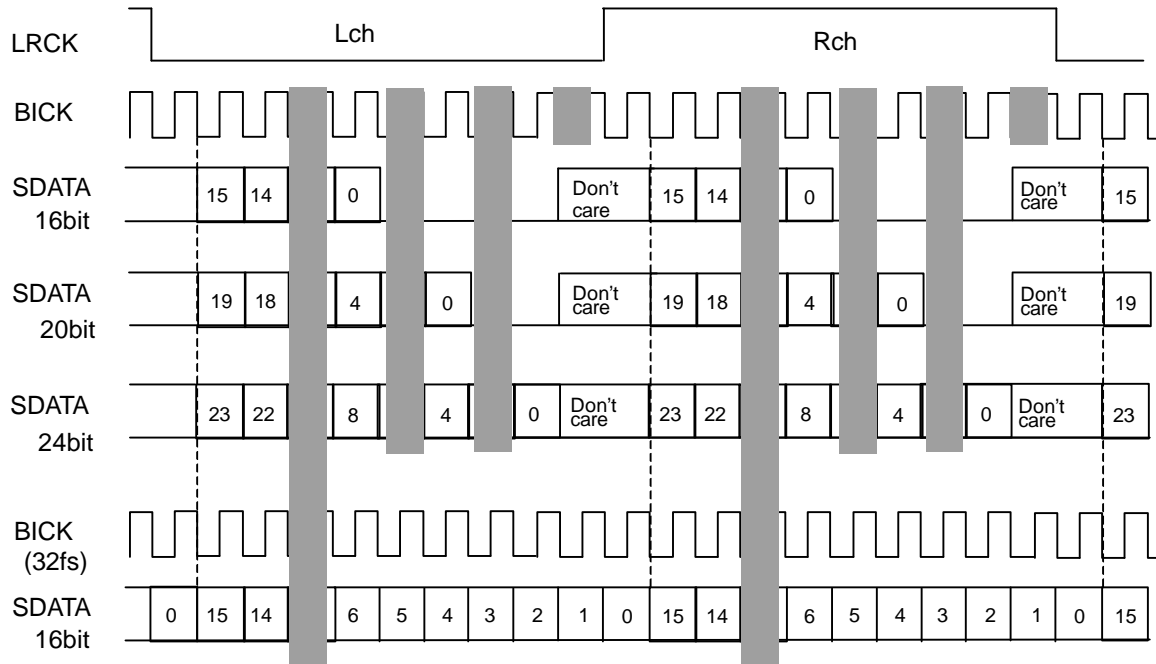

Figure 12. Mode 3 Timing

■ **Digital Attenuator**

The AK4366 has a channel-independent digital attenuator (256 levels, 0.5dB step). This digital attenuator is placed before the D/A converter. ATTL/R7-0 bits set the attenuation level (0dB to -127dB or MUTE) for each channel (Table 5). At DATTC= “1”, ATTL7-0 bits control both Lch and Rch attenuation levels. At DATTC= “0”, ATTL7-0 bits control the Lch level and ATTR7-0 bits control the Rch level. In parallel mode (P/S= “H”), digital attenuator is fixed to 0dB. When HPM= “1”, (L+R)/2 summation is done after volume control.

ATTL7-0 ATTR7-0	Attenuation
FFH	0dB
FEH	-0.5dB
FDH	-1.0dB
FCH	-1.5dB
:	:
:	:
02H	-126.5dB
01H	-127.0dB
00H	MUTE ($-\infty$)

Default

Table 5. Digital Volume ATT values

The ATS bit sets the transition time between set values of ATT7-0 bits as either 1061/fs or 7424/fs (Table 6). When ATS= “0”, a soft transition between the set values occurs(1062 levels). It takes 1061/fs (24ms@fs=44.1kHz) from FFH(0dB) to 00H(MUTE). The ATTs are 00H when the PMDAC bit is “0”. When the PMDAC returns to “1”, the ATTs fade to their current value. Digital attenuator is independent of the soft mute function.

ATS	ATT speed	
	0dB to MUTE	1 step
0	1061/fs	4/fs
1	7424/fs	29/fs

Default

Table 6. Transition time between set values of ATT7-0 bits

■ Soft Mute

Soft mute operation is performed at digital domain. In serial mode (P/S=“L”), when the SMUTE bit goes to “1”, the output signal is attenuated by $-\infty$ during $ATT_DATA \times ATT$ transition time (Table 6) from the current ATT level. When the SMUTE bit is returned to “0”, the mute is cancelled and the output attenuation gradually changes to the ATT level during $ATT_DATA \times ATT$ transition time. If the soft mute is cancelled before attenuating to $-\infty$ after starting the operation, the attenuation is discontinued and returned to ATT level by the same cycle. The soft mute is effective for changing the signal source without stopping the signal transmission. In parallel mode (P/S=“H”), soft mute is not available.

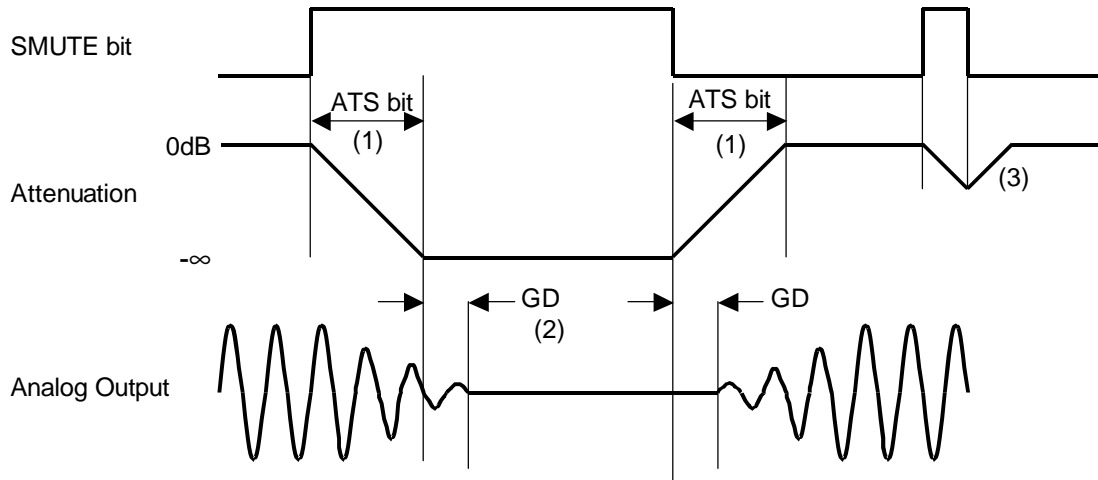

Figure 13. Soft Mute Function

Notes:

- (1) $ATT_DATA \times ATT$ transition time (Table 6). For example, this time is 3712LRCK cycles (3712/fs) at $ATS=1$ and $ATT_DATA=128$.
- (2) The analog output corresponding to the digital input has a group delay, GD.
- (3) If the soft mute is cancelled before attenuating to $-\infty$ after starting the operation, the attenuation is discontinued and returned to ATT level by the same cycle.

■ De-emphasis Filter

The AK4366 includes a digital de-emphasis filter ($t_c = 50/15\mu s$) by IIR filter corresponding to three sampling frequencies (32kHz, 44.1kHz and 48kHz). In serial mode (P/S= "L"), the de-emphasis filter is enabled by setting DEM1-0 bits (Table 7).

DEM1 bit	DEM0 bit	De-emphasis
0	0	44.1kHz
0	1	OFF
1	0	48kHz
1	1	32kHz

Default

Table 7. De-emphasis Filter Frequency Select (Serial Mode)

In parallel mode (P/S= "H"), the de-emphasis filter corresponding to 44.1kHz is enabled by setting DEM pin "H" (Table 8).

DEM pin	De-emphasis
L	OFF
H	44.1kHz

Table 8. De-emphasis Filter Frequency Select (Parallel Mode)

■ Bass Boost Function

In serial mode (P/S= "L"), the low frequency boost signal can be output from DAC by controlling BST1-0 bits (Table 9). The setting value is common in Lch and Rch.

BST1 bit	BST0 bit	BOOST
0	0	OFF
0	1	MIN
1	0	MID
1	1	MAX

Default

Table 9. Low Frequency Boost Select

■ System Reset

The AK4366 should be reset once by bringing PDN "L" upon power-up.

In serial mode (P/S= "L"), after exiting reset, VCOM, DAC, HPL and HPR switch to the power-down state. The contents of the control register are maintained until the reset is done. DAC exits reset and power down state by MCLK after PMDAC bit is changed to "1", and then DAC is powered up and the internal timing starts clocking by LRCK "↑". DAC is in power-down mode until MCLK and LRCK are input.

In parallel mode (P/S= "H"), VCOM and DAC are powered up by PDN pin "H". Headphone amp is powered up by MUTEN pin "H". DAC exits reset and power down state by MCLK after PDN pin goes to "H", and then DAC is powered up and the internal timing starts clocking by LRCK "↑". DAC is in power-down mode until MCLK and LRCK are input.

■ Headphone Output

Power supply voltage for the Headphone-amp is supplied from the HVDD pin and centered on the $0.45 \times VDD$ voltage. The Headphone-amp output load resistance is min. 16Ω .

1) Parallel mode (P/S= "H")

When MUTEN pin is set to "H" at PDN= "H", common voltage goes to $0.45 \times VDD$. When MUTEN pin is set to "L", common voltage goes to VSS, and the outputs (HPL and HPR pins) are VSS. When PDN pin is "L", headphone amplifiers are powered-down perfectly, and the outputs (HPL and HPR pins) are VSS.

2) Serial mode (P/S= "L")

When the MUTEN bit is "1" at PMHPL=PMHPR="1", the common voltage rises to $0.45 \times VDD$. When the MUTEN bit is "0", the common voltage of Headphone-amp falls and the outputs (HPL and HPR pins) go to VSS. When PMHPL and PMHPR bits are "0", the Headphone-amps are powered-down perfectly, and the outputs (HPL and HPR pins) are VSS.

A capacitor between the MUTET pin and ground reduces pop noise at power-up/down.

[Example] : A capacitor between the MUTET pin and ground = $1.0\mu\text{F}$:

Time constant of rise/fall time: $\tau = 100\text{ms}$

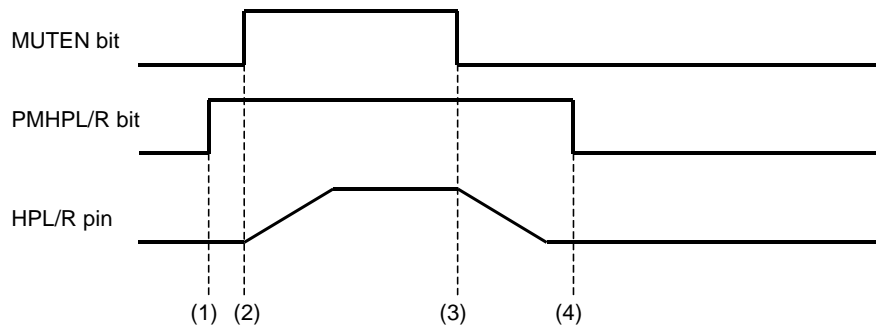

Figure 14. Power-up/Power-down Timing for Headphone-amp

- (1) Headphone-amp power-up (PMHPL and PMHPR bits= "1"). The outputs are still VSS.
- (2) Headphone-amp common voltage rise up (MUTEN bit= "1"). Common voltage of Headphone-amp is rising. This rise time depends on the capacitor value connected with the MUTET pin. The time constant is $\tau = 100k \times C$ when the capacitor value on MUTET pin is "C".
- (3) Headphone-amp common voltage fall down (MUTEN bit= "0"). Common voltage of Headphone-amp is falling to VSS. This fall time depends on the capacitor value connected with the MUTET pin. The time constant is $\tau = 100k \times C$ when the capacitor value on MUTET pin is "C".
- (4) Headphone-amp power-down (PMHPL, PMHPR bits= "0"). The outputs are VSS. If the power supply is switched off or Headphone-amp is powered-down before the common voltage goes to VSS, some POP noise occurs.

The cut-off frequency of Headphone-amp output depends on the external resistor and capacitor used. Table 10 shows the cut off frequency and the output power for various resistor/capacitor combinations. The headphone impedance R_L is 16Ω . Output powers are shown at $HVDD = 2.4, 3.0$ and $3.3V$. The output voltage of headphone is $0.58 \times V_{pp}$ @ $-3dBFS$.

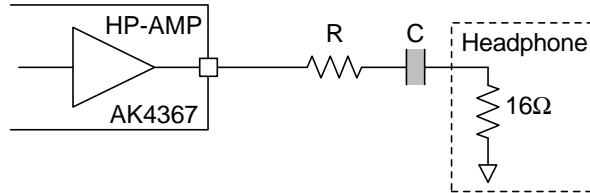

Figure 15. External Circuit Example of Headphone

R [Ω]	C [μF]	fc [Hz] BOOST=OFF	fc [Hz] BOOST=MIN	Output Power [mW]		
				2.4V	3.0V	3.3V
0	220	45	17	15	24	29
	100	100	43			
6.8	100	70	28	7	12	14
	47	149	78			
16	100	50	19	4	6	7
	47	106	47			

Table 10. Relationship of external circuit, output power and frequency response

■ Power-Up/Down Sequence

1) Parallel mode (P/S= "H")

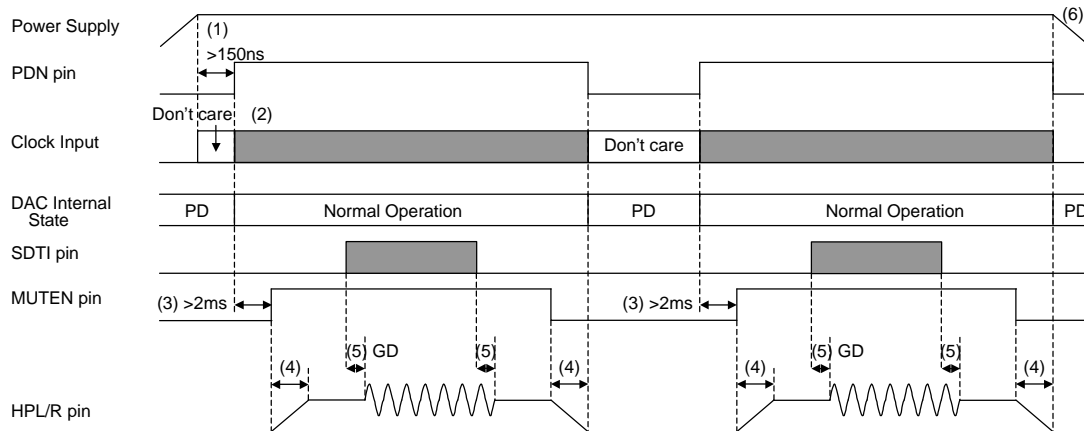

Figure 16. Power-up/down sequence of DAC and HP-amp

- (1) PDN pin should be set to "H" at least 150ns after the power is supplied.
- (2) External clocks (MCLK, BICK, LRCK) are needed to operate DAC. When PDN= "L", these clocks can be stopped. Headphone amp can operate without these clocks.
- (3) MUTEN pin should be set to "H" at least 2ms after PDN pin goes to "H".
- (4) Rise/Fall time of headphone amp is determined by external capacitor (C) of MUTET pin. Time constant is $100k \times C$. When $C=1\mu F$, time constant is 100ms.
PDN pin should be set to "L" after HPL and HPR pins go to VSS.
- (5) Analog output corresponding to digital input has the group delay (GD) of $20.8/fs$ ($=472\mu s$ at $fs=44.1kHz$).
- (6) Power supply should be switched off after headphone amp is powered down (HPL/R pins become "L").

2) Serial mode (P/S= "L")

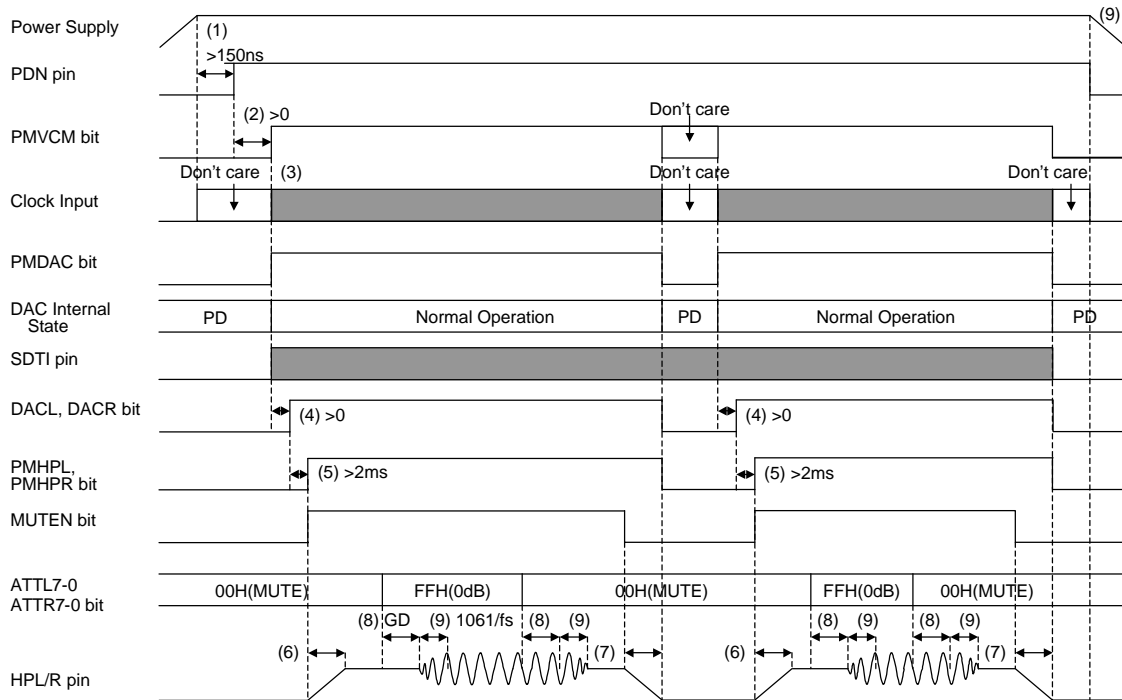

Figure 17. Power-up/down sequence of DAC and HP-amp

- (1) PDN pin should be set to "H" at least 150ns after the power is supplied.
- (2) PMVCM and PMDAC bits should be changed to "1" after PDN pin goes to "H".
- (3) External clocks (MCLK, BICK, LRCK) are needed to operate DAC. When PMDAC= "0", these clocks can be stopped. Headphone amp can operate without these clocks.
- (4) DACL and DACR bits should be changed to "1" after PMDAC bit is changed to "1".
- (5) PMHPL, PMHPR and MUTEN bits should be changed to "1" at least 2ms after DACL and DACR bits are changed to "1".
- (6) Rise time of headphone amp is determined by external capacitor (C) of MUTET pin. Time constant is $100k \times C$. When $C=1\mu F$, time constant is 100ms.
- (7) Fall time of headphone amp is determined by external capacitor (C) of MUTET pin. Time constant is $100k \times C$. When $C=1\mu F$, time constant is 100ms.
- PMHPL, PMHPR, DACL and DACR bits should be changed to "0" after HPL and HPR pins go to VSS.
- (8) Analog output corresponding to digital input has the group delay (GD) of $20.8/fs (=472\mu s @ fs=44.1kHz)$.
- (9) ATS bit sets transition time of digital attenuator. Default value is $1061/fs (=24ms @ fs=44.1kHz)$.
- (10) Power supply should be switched off after headphone amp is powered down (HPL/R pins become "L").

■ Mode Control Interface

Some function of AK4366 can be controlled by both pins (parallel control mode) and register (serial control mode) shown in Table 11. The serial control interface is enabled by the P/S pin = “L”. Internal registers may be written by 3-wire μ P interface pins: CSN, CCLK and CDTI. The data on this interface consists of Chip Address (2bits, fixed to “01”), Read/Write (1bit; fixed to “1”, Write only), Register Address (MSB first, 5bits) and Control Data (MSB first, 8bits). AK4367 latches the data on the rising edge of CCLK, so data should be clocked in on the falling edge. The writing of data becomes valid by CSN “ \uparrow ”. The clock speed of CCLK is 5MHz (max).

Function	Parallel mode	Serial mode
De-emphasis	44.1kHz	32kHz/44.1kHz/48kHz
SMUTE	X	O
Audio I/F Format	I2S, Left justified	I2S, Left Justified, Right justified
Digital Attenuator	X	O
Bass Boost	X	O
Power Management	X	O
Default State at PDN= “L” \rightarrow “H”	Power up	Power down

Table 11. Function list (O: available, X: not available)

PDN= “L” resets the registers to their default values. When the state of P/S pin is changed, AK4366 should be reset by PDN= “L”.

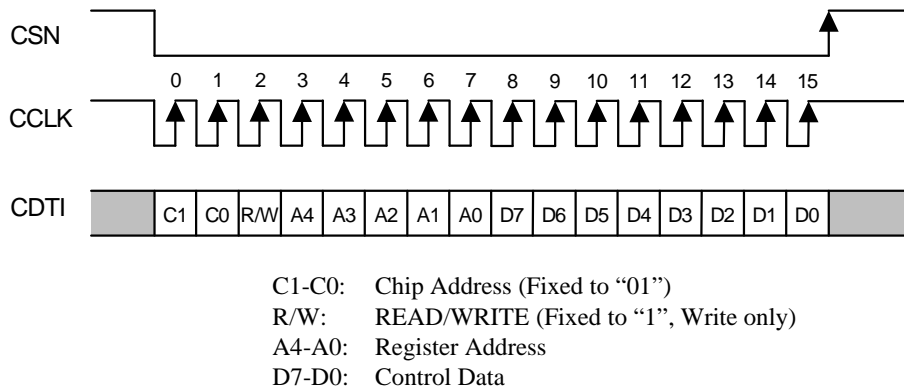

Figure 18. 3-wire Serial Control I/F Timing

■ Register Map

Addr	Register Name	D7	D6	D5	D4	D3	D2	D1	D0
00H	Power Management	0	0	0	MUTEN	PMHPR	PMHPL	PMDAC	PMVCM
01H	Mode Control 0	0	MCKAC	HPM	DIF2	DIF1	DIF0	DFS1	DFS0
02H	Mode Control 1	0	0	0	SMUTE	BST1	BST0	DEM1	DEM0
03H	Mode Control 2	0	0	0	0	ATS	DATTC	BCKP	LRP
04H	DAC Lch ATT	ATTL7	ATTL6	ATTL5	ATTL4	ATTL3	ATTL2	ATTL1	ATTL0
05H	DAC Rch ATT	ATTR7	ATTR6	ATTR5	ATTR4	ATTR3	ATTR2	ATTR1	ATTR0
06H	Output Select	0	0	0	0	0	0	DACR	DACL

All registers inhibit writing at PDN pin = "L".

For addresses from 07H to 1FH, data must not be written.

■ Register Definitions

Addr	Register Name	D7	D6	D5	D4	D3	D2	D1	D0
00H	Power Management	0	0	0	MUTEN	PMHPR	PMHPL	PMDAC	PMVCM
	R/W	RD	RD	RD	R/W	R/W	R/W	R/W	R/W
	Default	0	0	0	0	0	0	0	0

PMVCM: Power Management for VCOM Block

0: Power OFF (Default)

1: Power ON

In parallel mode (P/S= "H"), PMVCM bit is fixed to "1".

PMDAC: Power Management for DAC Blocks

0: Power OFF (Default)

1: Power ON

When PMDAC bit is changed from "0" to "1", DAC is powered-up to the current register values (ATT value, sampling rate, etc). In parallel mode (P/S= "H"), PMDAC bit is fixed to "1".

PMHPL: Power Management for Lch of Headphone Amp

0: Power OFF (Default). HPL pin becomes VSS(0V).

1: Power ON

PMHPR: Power Management for Rch of Headphone Amp

0: Power OFF (Default). HPR pin becomes VSS(0V).

1: Power ON

MUTEN: Headphone Amp Mute Control

0: Mute (Default). HPL and HPR pins go to VSS(0V).

1: Normal operation. HPL and HPR pins go to 0.45 x VDD.

All blocks can be powered-down by setting the PDN pin to "L" regardless of register values setup. All blocks can be also powered-down by setting all power management bits to "0". In this case, control register values are maintained.

Addr	Register Name	D7	D6	D5	D4	D3	D2	D1	D0
01H	Mode Control 0	0	MCKAC	HPM	DIF2	DIF1	DIF0	DFS1	DFS0
	R/W	RD	R/W	R/W	R/W	R/W	R/W	R/W	R/W
	Default	0	0	0	0	1	0	0	0

DFS1-0: Oversampling Speed Select (Table 2)
Default: "00" (64fs)

DIF2-0: Audio Data Interface Format Select (Table 3)
Default: "10" (Mode 2)

HPM: Mono Output Select of Headphone (Table 12)
0: Normal Operation (Default)
1: Mono. (L+R)/2 signals from the DAC are output to both Lch and Rch of headphone.

DACL	DACR	HPM	HPL pin Output	HPR pin Output	
0	0	x	No output from DAC	No output from DAC	Default
0	1	0	No output from DAC	Output from Rch of DAC by 0dB	
		1	No output from DAC	Output from Rch of DAC by -6dB	
1	0	0	Output from Lch of DAC by 0dB	No output from DAC	
		1	Output from Lch of DAC by -6dB	No output from DAC	
1	1	0	Output from Lch of DAC by 0dB	Output from Rch of DAC by 0dB	
		1	Output (L+R)/2 from DAC	Output (L+R)/2 from DAC	

Table 12. Mono Output Select of Headphone (x: Don't care)

MCKAC: MCLK Input Mode Select
0: CMOS input (Default)
1: AC coupling input

Addr	Register Name	D7	D6	D5	D4	D3	D2	D1	D0
02H	Mode Control 1	0	0	0	SMUTE	BST1	BST0	DEM1	DEM0
	R/W	RD	RD	RD	R/W	R/W	R/W	R/W	R/W
	Default	0	0	0	0	0	0	0	1

DEM1-0: De-emphasis Filter Frequency Select (Table 7)
Default: "01" (OFF)

BST1-0: Low Frequency Boost Function Select (Table 9)
Default: "00" (OFF)

SMUTE: Soft Mute Control
0: Normal operation (Default)
1: DAC outputs soft-muted

Addr	Register Name	D7	D6	D5	D4	D3	D2	D1	D0
03H	Mode Control 2	0	0	0	0	ATS	DATTC	BCKP	LRP
	R/W	RD	RD	RD	RD	R/W	R/W	R/W	R/W
	Default	0	0	0	0	0	0	0	0

LRP: LRCK Polarity Select

- 0: Normal
- 1: Invert

BCKP: BICK Polarity Select

- 0: Normal
- 1: Invert

DATTC: DAC Digital Attenuator Control Mode Select

- 0: Independent (Default)
- 1: Dependent

At DATTC= "1", ATTL7-0 bits control both Lch and Rch attenuation level, while register values of ATTL7-0 bits are not written to ATTR7-0 bits. At DATTC= "0", ATTL7-0 bits control Lch level and ATTR7-0 bits control Rch level.

ATS: Digital attenuator transition time setting (Table 6)

Default: "00" (1061/fs)

Addr	Register Name	D7	D6	D5	D4	D3	D2	D1	D0
04H	DAC Lch ATT	ATTL7	ATTL6	ATTL5	ATTL4	ATTL3	ATTL2	ATTL1	ATTL0
05H	DAC Rch ATT	ATTR7	ATTR6	ATTR5	ATTR4	ATTR3	ATTR2	ATTR1	ATTR0
	R/W	R/W	R/W	R/W	R/W	R/W	R/W	R/W	R/W
	Default	0	0	0	0	0	0	0	0

ATTL7-0: Setting of the attenuation value of output signal from DACL (Table 5)

ATTR7-0: Setting of the attenuation value of output signal from DACR (Table 5)

Default: "00H" (MUTE)

The AK4566 has channel-independent digital attenuator (256 levels, 0.5dB step). This digital attenuator is placed before D/A converter. ATTL/R7-0 bits set the attenuation level (0dB to -127dB or MUTE) of each channel. Digital attenuator is independent of soft mute function.

Addr	Register Name	D7	D6	D5	D4	D3	D2	D1	D0
06H	Output Select	0	0	0	0	0	0	DACR	DACL
	R/W	RD	RD	RD	RD	RD	RD	R/W	R/W
	Default	0	0	0	0	0	0	0	0

DACL: DAC Lch output signal is output to Lch of headphone amp.

- 0: OFF (Default)
- 1: ON

DACR: DAC Rch output signal is output to Rch of headphone amp.

- 0: OFF (Default)
- 1: ON

SYSTEM DESIGN

Figure 19 shows the system connection diagram. An evaluation board [AKD4366] is available which demonstrates the optimum layout, power supply arrangements and measurement results.

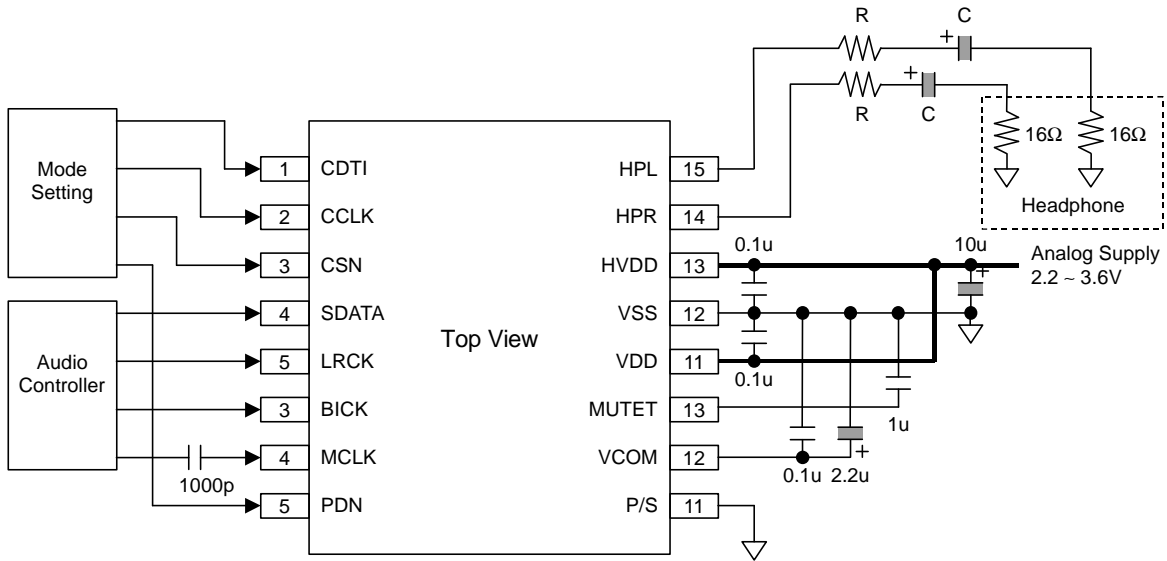

Figure 19. Typical Connection Diagram (In case of AC coupling to MCLK)
(Serial mode)

1. Grounding and Power Supply Decoupling

The AK4366 requires careful attention to power supply and grounding arrangements. VDD and HVDD are usually supplied from the analog power supply in the system. When VDD and HVDD are supplied separately, VDD must be powered-up at the same time or earlier than HVDD. When the AK4366 is powered-down, HVDD must be powered-down at the same time or later than VDD. VSS must be connected to the analog ground plane. System analog ground and digital ground should be connected together near to where the supplies are brought onto the printed circuit board. Decoupling capacitors should be as close to the AK4366 as possible, with the small value ceramic capacitors being the nearest.

2. Voltage Reference

The input voltage to VDD pin sets the analog output range. A 0.1 μ F ceramic capacitor and a 10 μ F electrolytic capacitor is connected between VDD and VSS pins, normally. VCOM is a signal ground of this chip (0.45 x VDD). An electrolytic 2.2 μ F in parallel with a 0.1 μ F ceramic capacitor attached between VCOM and VSS pins eliminates the effects of high frequency noise. No load current may be drawn from VCOM pin. All signals, especially clock, should be kept away from VDD and VCOM pins in order to avoid unwanted coupling into the AK4366.

3. Analog Outputs

The analog outputs are single-ended outputs and $0.58 \times VDD$ $V_{pp}(typ)$ @ -3dBFS centered on the VCOM voltage. The input data format is 2's complement. The output voltage is a positive full scale for 7FFFFFFH (@24bit) and negative full scale for 800000H (@24bit). The ideal output is VCOM voltage for 000000H (@24bit). If the noise generated by the delta-sigma modulator beyond the audio band causes problems, attenuation by an external filter is required.

DC offsets on the analog outputs is eliminated by AC coupling since the analog outputs have a DC offset equal to VCOM plus a few mV.

PACKAGE

16pin TSSOP (Unit: mm)

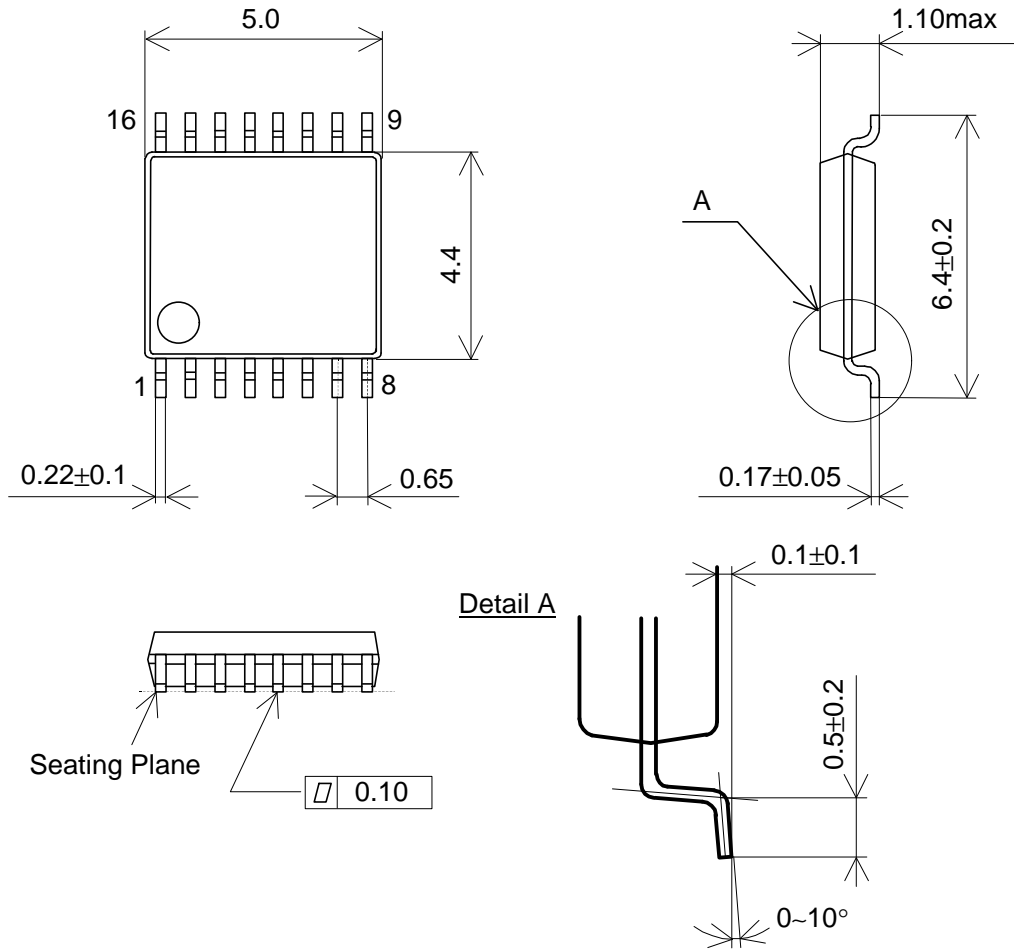

■ Package & Lead frame material

- Package molding compound: Epoxy
- Lead frame material: Cu
- Lead frame surface treatment: Solder (Pb free) plate

MARKING

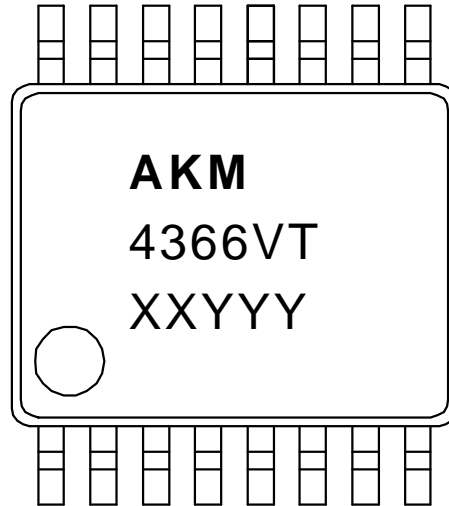

- 1) Pin #1 indication
- 2) Date Code : XXYYY (5 digits)
 XX: Lot#
 YYY: Date Code
- 3) Marketing Code : 4366VT

IMPORTANT NOTICE

- These products and their specifications are subject to change without notice. Before considering any use or application, consult the Asahi Kasei Microsystems Co., Ltd. (AKM) sales office or authorized distributor concerning their current status.
- AKM assumes no liability for infringement of any patent, intellectual property, or other right in the application or use of any information contained herein.
- Any export of these products, or devices or systems containing them, may require an export license or other official approval under the law and regulations of the country of export pertaining to customs and tariffs, currency exchange, or strategic materials.
- AKM products are neither intended nor authorized for use as critical components in any safety, life support, or other hazard related device or system, and AKM assumes no responsibility relating to any such use, except with the express written consent of the Representative Director of AKM. As used here:
 - a. A hazard related device or system is one designed or intended for life support or maintenance of safety or for applications in medicine, aerospace, nuclear energy, or other fields, in which its failure to function or perform may reasonably be expected to result in loss of life or in significant injury or damage to person or property.
 - b. A critical component is one whose failure to function or perform may reasonably be expected to result, whether directly or indirectly, in the loss of the safety or effectiveness of the device or system containing it, and which must therefore meet very high standards of performance and reliability.
- It is the responsibility of the buyer or distributor of an AKM product who distributes, disposes of, or otherwise places the product with a third party to notify that party in advance of the above content and conditions, and the buyer or distributor agrees to assume any and all responsibility and liability for and hold AKM harmless from any and all claims arising from the use of said product in the absence of such notification.