



140 COMMERCE DRIVE  
MONTGOMERYVILLE, PA  
18936-1013  
PHONE: (215) 631-9840  
FAX: (215) 631-9855

**BFR91**

## RF & MICROWAVE DISCRETE LOW POWER TRANSISTORS

### Features

- High Current-Gain – Bandwidth Product,  $fT = 5 \text{ GHz (typ) @ } I_C = 30 \text{ mA}$
- Low Noise Figure –  $NF = 1.9 \text{ dB (typ) @ } f = 0.5 \text{ GHz}$ ,  $2.5 \text{ dB (typ) @ } 1\text{GHz}$
- High Power Gain –  $G_{max} = 16 \text{ dB (typ) @ } f = 0.5 \text{ GHz}$ ,  $10.9\text{dB (typ) @ } 1\text{GHz}$

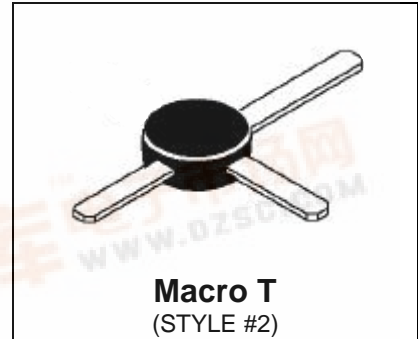

DESCRIPTION: Designed primarily for use in high-gain, low noise, small-signal amplifiers. Also used in applications requiring fast switching times.

### ABSOLUTE MAXIMUM RATINGS (T<sub>case</sub> = 25°C)

Symbol	Parameter	Value	Unit
V <sub>CEO</sub>	Collector-Emitter Voltage	12	Vdc
V <sub>CBO</sub>	Collector-Base Voltage	15	Vdc
V <sub>EBO</sub>	Emitter-Base Voltage	3.0	Vdc
I <sub>C</sub>	Collector Current	35	mA

### Thermal Data

P <sub>D</sub>	Total Device Dissipation @ TA = 60°C Derate above 60°C	180 2.0	mWatts mW/ °C
T <sub>stg</sub>	Storage Temperature	-65 to +150	°C
R <sub>θJA</sub>	Total Device Dissipation @ TA = 60°C Derate above 60°C	500	°C/W



ELECTRICAL SPECIFICATIONS (Tcase = 25°C)

STATIC  
 (off)

Symbol	Test Conditions	Value			Unit
		Min.	Typ.	Max.	
BVCEO	Collector-Emitter Breakdown Voltage (IC = 1.0 mA <sub>dc</sub> , IB = 0)	12	-	-	V <sub>dc</sub>
BVCB0	Collector-Base Breakdown Voltage (IC = 0.1 mA <sub>dc</sub> , IE = 0)	15	-	-	V <sub>dc</sub>
BVEBO	Emitter-Base Breakdown Voltage (IE = 0.1 mA <sub>dc</sub> , IC = 0)	3.0	-	-	V <sub>dc</sub>
ICBO	Collector Cutoff Current (VCB = 5.0 V <sub>dc</sub> , VBE = 0 V <sub>dc</sub> )	-	-	50	nA

(on)

HFE	DC Current Gain (IC = 30 mA <sub>dc</sub> , VCE = 5.0 V <sub>dc</sub> )	25	-	250	-
-----	--	----	---	-----	---

DYNAMIC

Symbol	Test Conditions	Value			Unit
		Min.	Typ.	Max.	
F <sub>tau</sub>	Current-Gain – Bandwidth Product (IC = 30 mA, VCE = 5.0 V <sub>dc</sub> , f = 0.5 GHz)	-	5.0	-	GHz
CCB	Output Capacitance (VCB = 10 V <sub>dc</sub> , IE = 0, f = 1.0 MHz)	-	0.7	1.0	pF

BFR91

FUNCTIONAL

Symbol	Test Conditions	Value			Unit
		Min.	Typ.	Max.	
NF	Noise Figure (IC = 2.0 mAdc, VCE = 5.0 Vdc, f = 0.5 GHz) (IC = 2.0 mAdc, VCE = 5.0 Vdc, f = 1.0 GHz)	-	1.9 2.5	-	dB
GNF	Power Gain at Optimum Noise Figure (IC = 2.0 mAdc, VCE = 5.0 Vdc, f = 0.5 GHz) (IC = 2.0 mAdc, VCE = 5.0 Vdc, f = 1.0 GHz)	-	11 8.0	-	dB
$ S_{21} ^2$	Insertion Gain (IC = 30 mAdc, VCE = 5.0 Vdc, f = 0.5 GHz) (IC = 30 mAdc, VCE = 5.0 Vdc, f = 1.0 GHz)	14.5	15.5 10.2	-	dB
MSG	Maximum Stable Gain (IC = 30 mAdc, VCE = 5.0 Vdc, f = 0.5 GHz) (IC = 30 mAdc, VCE = 5.0 Vdc, f = 1.0 GHz)	-	18.6 12.9	-	dB
$G_{U \max}$	Maximum Unilateral Gain (1) (IC = 30 mAdc, VCE = 5.0 Vdc, f = 0.5 GHz) (IC = 30 mAdc, VCE = 5.0 Vdc, f = 1.0 GHz)	-	16.5 10.9	-	dB

**Table 1. Common Emitter S-Parameters, @ VCE = 5.0 V, IC = 30 mA**

f (MHz)	S11		S21		S12		S22	
	S11	$\angle \phi$	S21	$\angle \phi$	S12	$\angle \phi$	S22	$\angle \phi$
100	0.258	-115	25.77	123	0.021	76	0.536	-33
200	0.290	-149	14.66	103	0.038	74	0.384	-43
300	0.298	-164	10.05	94	0.054	75	0.311	-45
500	0.305	-179	6.18	84	0.085	75	0.264	-49
700	0.302	170	4.5	77	0.117	73	0.256	-52
800	0.304	166	3.98	73	0.133	72	0.257	-54
1000	0.304	158	3.24	67	0.166	70	0.251	-57
1500	0.256	134	2.3	54	0.24	65	0.263	-69

**BFR91**

**RF Low Power PA, LNA, and General Purpose RF Discrete Selector Guide**

Package	Device	Type	GPE Freq (MHz)	Pout (watts)	GPE (dB)	Efficiency (%)	GPE VCC	BVCEO	IC max (mA)
SO-8	MRF4427, R2	NPN	175	0.15	18	60	12	20	400
TO-39	2N4427	NPN	175	1	10	50	12	20	400
POWER MACRO	MRF553	NPN	175	1.5	11.5	60	12.5	16	500
POWER MACRO	MRF553T	NPN	175	1.5	11.5	50	12.5	16	500
TO-39	MRF607	NPN	175	1.75	11.5	50	12.5	16	330
TO-39	2N6255	NPN	175	3	7.8	50	12.5	18	1000
TO-72	2N5179	NPN	200		20		6	12	50
MACRO X	MRF559	NPN	512	0.5	10	65	7.5	16	150
MACRO X	MRF559	NPN	512	0.5	13	60	12.5	16	150
TO-39	2N3866A	NPN	400	1	10	45	28	30	400
SO-8	MRF3866, R1, R2	NPN	400	1	10	45	28	30	400
POWER MACRO	MRF555	NPN	470	1.5	11	50	12.5	16	400
POWER MACRO	MRF555T	NPN	470	1.5	11	50	12.5	16	400
MACRO X	MRF559	NPN	870	0.5	6.5	70	7.5	16	150
MACRO X	MRF559	NPN	870	0.5	9.5	65	12.5	16	150
SO-8	MRF8372, R1, R2	NPN	870	0.75	8	55	12.5	16	200
POWER MACRO	MRF557	NPN	870	1.5	8	55	12.5	16	400
POWER MACRO	MRF557T	NPN	870	1.5	8	55	12.5	16	400

Package	Device	Type	Freq (MHz)	NF (dB)	NF IC (mA)	NF VCE	GN (dB)	Gu Max (dB)	Ftau (MHz)	Ccb(pF)	BVCEO	IC max (mA)
TO-39	2N5109	NPN	200	3	10	15		12	1200	3.5	20	400
TO-39	MRF5943C	NPN	200	3.4	30	15		11.4	1000		30	400
SO-8	MRF5943, R1, R2	NPN	200	3.4	30	15		15	1300		30	400
TO-72	2N5179	NPN	200	4.5	1.5	6		17	900	1	12	50
TO-72	2N2857	NPN	300	5.5	50	6		13	1600	1	15	40
TO-39	MRF517	NPN	300	7.5	50	15		5.5	4600	3	25	150
TO-72	MRF904	NPN	450	1.5	5	6		11	4000	1	15	30
TO-72	2N6304	NPN	450	5	2	5		14	1400	1	15	50
MACRO T	BFR91	NPN	500	1.9	2	5	11	16.5	5000	1	12	35
MACRO T	BFR96	NPN	500	2	10	10		14.5	5000	2.6	15	100
SO-8	MRF5812, R1, R2	NPN	500	2	50	10	15.5	17.8	5000		15	200
MACRO X	MRF581A	NPN	500	2	50	10	14	15	5000		15	200
Macro	BFR90	NPN	500	2.4	2	10	15	18	5000	1	15	30
TO-72	BFY90	NPN	500	2.5	2	5		20	1300		15	50
TO-72	MRF914	NPN	500	2.5	5	10		15	4500		12	40
MACRO X	MRF581	NPN	500	2.5	50	10	15	17.8	5000		16	200
TO-39	MRF586	NPN	500	3	90	15	11	14.5	4500	2.2	17	200
MACRO X	MRF951	NPN	1000	1.3	5	6	14	17	8000	0.45	10	100
MACRO X	MRF571	NPN	1000	1.5	10	6	10		8000	1	10	70
MACRO T	BFR91	NPN	1000	2.5	2	5	8	11	5000	1	12	35
MACRO T	BFR90	NPN	1000	3	2	10	10	12.5	5000	1	15	30
TO-39	MRF545	PNP						14	1400	2	70	400
TO-39	MRF544	NPN						13.5	1500		70	400

RF (Low Power PA / General Purpose) Selection Guide

RF (LNA / General Purpose) Selection Guide

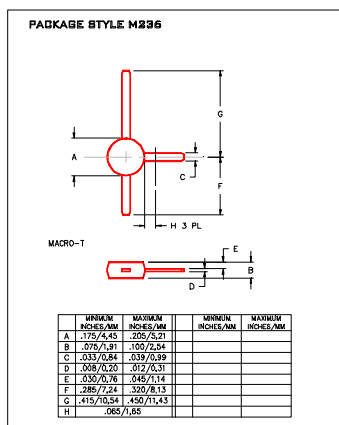

Macro T

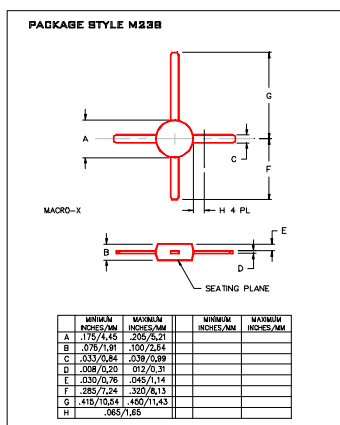

Macro X

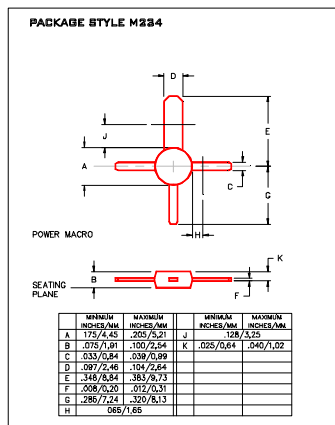

Power Macro

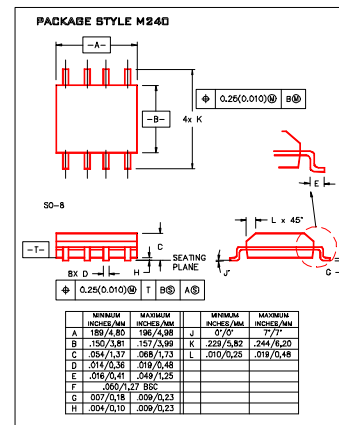

SO-8

**BFR91**

PACKAGE STYLE M236

PIN 1. COLLECTOR  
 2. EMITTER  
 3. BASE

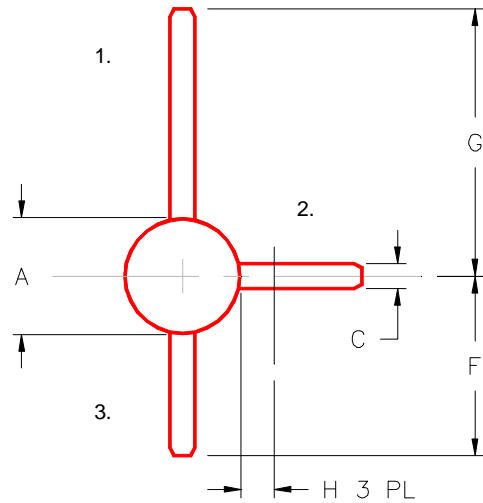

MACRO-T

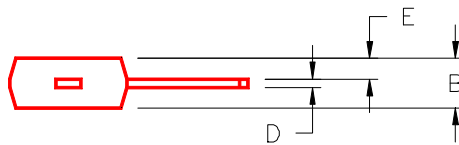

	MINIMUM INCHES/MM	MAXIMUM INCHES/MM		MINIMUM INCHES/MM	MAXIMUM INCHES/MM
A	.175/4,45	.205/5,21			
B	.075/1,91	.100/2,54			
C	.033/0,84	.039/0,99			
D	.008/0,20	.012/0,31			
E	.030/0,76	.045/1,14			
F	.285/7,24	.320/8,13			
G	.415/10,54	.450/11,43			
H	.065/1,65				