

Bt868/Bt869

Flicker-Free Video Encoder with UltraScale™ Technology

The Bt868/869 is specifically designed for video systems requiring the generation of high-quality flicker-free composite and Y/C (S-video) signals from various YCrCb or RGB digital streams. The Bt868/869 accepts any input format from 640 x 480 to 800 x 600 resolution.

The Bt868/869 uses Conexant's UltraScale™ technology to provide the most advanced vertical and horizontal scaling necessary for the display of non-interlaced data on interlaced devices such as the TV. The UltraScale™ technology converts the lines of input pixel data to the appropriate number of output lines for producing a full-screen, high-quality image.

The Bt868/869 performs 5-line vertical filtering, which includes poly phase interpolation scaling for overscan compensation and flicker filtering. Horizontal scaling for overscan compensation is achieved by altering the encoder clock frequency. This approach preserves all of the high frequency components of the input signals, which are essential for the highest quality display of text intensive images such as web pages on TVs. The amount of flicker filtering and overscan compensation is programmable.

Worldwide video standards are supported, including NTSC-M (N. America, Taiwan, Japan), PAL-B,D,G,H,I (Europe, Asia), PAL-M (Brazil), PAL-N (Uruguay, Paraguay), and PAL-Nc (Argentina). Bt868 and Bt869 are functionally identical, with the exception that Bt869 can output Macrovision Level 7.0 anticopy algorithm.

Functional Block Diagram

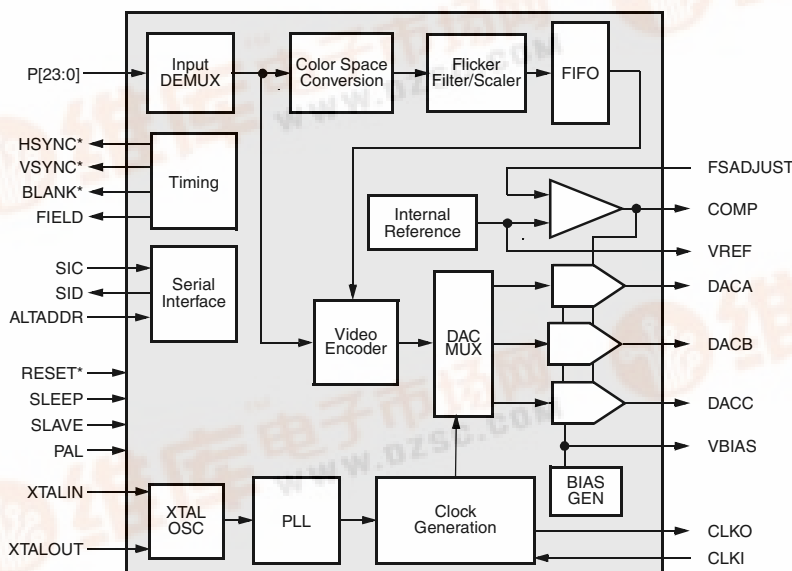

Distinguishing Features

- Digital RGB or YCrCb non-interlaced input to interlaced or non-interlaced analog TV output modes:
 - YCrCb Modes:
 - 16-bit 4:2:2 multiplexed 8-bit
 - 24-bit 4:4:4 multiplexed 12-bit
 - 24-bit 4:4:4 non-multiplexed 24-bit
 - RGB Modes:
 - 15/16 bit 5:6:5 RGB multiplexed 8-bit
 - 24-bit 8:8:8 RGB multiplexed 12-bit
 - 24-bit 8:8:8 RGB non-multiplexed 24-bit
- Digital RGB non-interlaced input to analog RGB noninterlaced (VGA/SVGA) output modes:
 - 15/16 bit 5:6:5 RGB multiplexed 8-bit
 - 24-bit 8:8:8 RGB multiplexed 12-bit
 - 24-bit 8:8:8 RGB non-multiplexed 24-bit
- Support for NTSC/PAL outputs in the following modes:
 - Interlaced and non-interlaced outputs
 - S-video output (simultaneous with composite NTSC or PAL outputs)
 - Component YUV analog output mode
- 5-line vertical filtering scaling for overscan compensation and flicker filtering
- CCIR601 compatible input mode
- Luma and chroma comb filtering
- 3 x 10-bit DACs
- 6 MHz Luma bandwidth
- Macrovision 7.0 copy protection
- 80-pin PQFP package
- 3.3 V operation with 5 V tolerant IOs
- 2-line serial programming interface
- Power-Down modes
- Master/slave video timing operation
- TV connected register flag
- Automatic configuration

Applications

- Desktop/Portable PCs with TV-Out
- Living-room PCs
- Internet PC/TVs
- Internet Appliances

Ordering Information

Model Number	Package	Ambient Temperature Range	Reduced Features
Bt868KRF	80-pin PQFP	0° C to +70° C	No Macrovision Feature
Bt869KRF	80-pin PQFP	0° C to +70° C	—

© 2000, Conexant Systems, Inc.
All Rights Reserved.

Information in this document is provided in connection with Conexant Systems, Inc. ("Conexant") products. These materials are provided by Conexant as a service to its customers and may be used for informational purposes only. Conexant assumes no responsibility for errors or omissions in these materials. Conexant may make changes to specifications and product descriptions at any time, without notice. Conexant makes no commitment to update the information and shall have no responsibility whatsoever for conflicts or incompatibilities arising from future changes to its specifications and product descriptions.

No license, express or implied, by estoppel or otherwise, to any intellectual property rights is granted by this document. Except as provided in Conexant's Terms and Conditions of Sale for such products, Conexant assumes no liability whatsoever.

THESE MATERIALS ARE PROVIDED "AS IS" WITHOUT WARRANTY OF ANY KIND, EITHER EXPRESS OR IMPLIED, RELATING TO SALE AND/OR USE OF CONEXANT PRODUCTS INCLUDING LIABILITY OR WARRANTIES RELATING TO FITNESS FOR A PARTICULAR PURPOSE, CONSEQUENTIAL OR INCIDENTAL DAMAGES, MERCHANTABILITY, OR INFRINGEMENT OF ANY PATENT, COPYRIGHT OR OTHER INTELLECTUAL PROPERTY RIGHT. CONEXANT FURTHER DOES NOT WARRANT THE ACCURACY OR COMPLETENESS OF THE INFORMATION, TEXT, GRAPHICS OR OTHER ITEMS CONTAINED WITHIN THESE MATERIALS. CONEXANT SHALL NOT BE LIABLE FOR ANY SPECIAL, INDIRECT, INCIDENTAL, OR CONSEQUENTIAL DAMAGES, INCLUDING WITHOUT LIMITATION, LOST REVENUES OR LOST PROFITS, WHICH MAY RESULT FROM THE USE OF THESE MATERIALS.

Conexant products are not intended for use in medical, lifesaving or life sustaining applications. Conexant customers using or selling Conexant products for use in such applications do so at their own risk and agree to fully indemnify Conexant for any damages resulting from such improper use or sale.

The following are trademarks of Conexant Systems, Inc.: Conexant™, the Conexant C symbol, and "What's Next in Communications Technologies"™. Product names or services listed in this publication are for identification purposes only, and may be trademarks of third parties. Third-party brands and names are the property of their respective owners.

For additional disclaimer information, please consult Conexant's Legal Information posted at www.conexant.com, which is incorporated by reference.

Reader Response: Conexant strives to produce quality documentation and welcomes your feedback. Please send comments and suggestions to tech.pubs@conexant.com. For technical questions, contact your local Conexant [sales office](#) or field applications engineer.

Table of Contents

List of Figures	vii
List of Tables	ix
1.0 Functional Description	1-1
1.1 Pin Descriptions	1-1
1.2 GUI Controller Programmability and Frequency Requirement	1-6
1.3 Circuit Description	1-9
1.3.1 Overview	1-9
1.3.2 Reset	1-9
1.3.3 Timing Registers	1-9
1.3.4 Device Initialization	1-10
1.3.5 Auto Configuration	1-10
1.3.6 Clocking and Timing Generation	1-13
1.3.7 Master and Slave Modes	1-14
1.3.8 Input Formats	1-15
1.3.9 Pixel Input Timing	1-15
1.3.10 Output Modes	1-15
1.3.11 YCrCb Inputs	1-16
1.3.12 RGB Inputs	1-17
1.3.13 Video Amplitude Scaling	1-17
1.3.14 Input Pixel Horizontal Sync	1-18
1.3.15 Input Pixel Vertical Sync	1-19
1.3.16 Input Pixel Blanking	1-19
1.3.17 Overscan Compensation and Flicker Filtering	1-20
1.3.18 VGA Compatibility	1-21
1.3.19 Analog Horizontal Sync	1-21
1.3.20 Analog Vertical Sync	1-21
1.3.21 Analog Video Blanking	1-21
1.3.22 Video Standards	1-21
1.3.23 Subcarrier Generation	1-29
1.3.24 Burst Generation	1-30
1.3.25 Chrominance Disable	1-30
1.3.26 Digital Processing	1-30
1.3.27 Subcarrier Phasing	1-31

1.3.28	Noninterlaced Operation	1-31
1.3.29	Closed Captioning	1-32
1.3.30	Internal Color Bars	1-32
1.3.31	Macrovision Encoding	1-32
1.3.32	Outputs	1-33
1.3.33	Output Connection Status	1-33
1.3.34	Output Filtering and SINX/X Compensation	1-33
1.3.35	Power-Down Modes	1-34
1.3.36	Serial Interface	1-34
2.0	Internal Registers	2-1
2.1	Essential Registers	2-3
2.2	Writing Addresses	2-3
2.3	Reading Information	2-3
3.0	PC Board Considerations	3-1
3.1	Component Placement	3-1
3.2	Power and Ground Planes	3-1
3.3	Decoupling	3-5
3.3.1	Device Decoupling	3-5
3.3.2	Power Supply Decoupling	3-5
3.3.3	COMP Decoupling	3-5
3.3.4	VREF Decoupling	3-5
3.3.5	VBIAS Decoupling	3-5
3.4	Signal Interconnect	3-6
3.4.1	Digital Signal Interconnect	3-6
3.4.2	Analog Signal Interconnect	3-6
3.5	Applications Information	3-7
3.5.1	Electrostatic Discharge and Latchup Considerations	3-7
3.5.2	Clock and Subcarrier Stability	3-7
3.5.3	Filtering Radio Frequency Modulator Connection	3-8
3.6	Bt868/Bt869 Evaluation Board	3-9
3.7	Serial Interface	3-16
3.7.1	Data Transfer on the Serial Interface Bus	3-16
4.0	Parametric Information	4-1
4.1	DC Electrical Parameters	4-1
4.2	AC Electrical Parameters	4-4
4.3	Mechanical Drawing	4-9
Appendix A. Scaling and I/O Timing Register Calculations		A-1
Appendix B. Approved Crystal Vendors		B-1

List of Figures

Figure 1-1.	Pinout Diagram	1-1
Figure 1-2.	Flicker Filter Control Diagram—External Use	1-7
Figure 1-3.	Encoder Core.	1-8
Figure 1-4.	Decimation Filter at $F_s=27$ MHz.	1-16
Figure 1-5.	Interlaced 525-Line (NTSC) Video Timing	1-22
Figure 1-6.	Interlaced 525-Line (PAL-M) Video Timing	1-23
Figure 1-7.	Interlaced 625-Line (PAL-B, D, G, H, I, Nc) Video Timing (Fields 1–4).	1-24
Figure 1-8.	Interlaced 625-Line (PAL-B, D, G, H, I, Nc) Video Timing (Fields 5–8).	1-25
Figure 1-9.	Interlaced 625-Line (PAL-N) Video Timing (Fields 1–4)	1-26
Figure 1-10.	Interlaced 625-Line (PAL-N) Video Timing (Fields 5–8)	1-27
Figure 1-11.	Noninterlaced 262-Line (NTSC) Video Timing	1-28
Figure 1-12.	Noninterlaced 262-Line (PAL-M) Video Timing	1-28
Figure 1-13.	Noninterlaced 312-Line (PAL-B, D, G, H, I, N, Nc) Video Timing	1-29
Figure 1-14.	Three-Stage Chroma Filter.	1-30
Figure 1-15.	Luminance Upsampling Filter Response	1-31
Figure 3-1.	Power Plane Illustration	3-2
Figure 3-2.	Connection Diagram for Output Filters and Other Key Passive Components	3-3
Figure 3-3.	Complete Bt868/Bt869 Recommended Layout	3-4
Figure 3-4.	Bt868/Bt869 Evaluation Board.	3-10
Figure 3-5.	SID/SIC Diagram	3-16
Figure 4-1.	Interface Timing	4-6
Figure 4-2.	Master Mode with Flicker Filter Interface Timing	4-7
Figure 4-3.	Slave Mode with Flicker Filter Interface Timing	4-8
Figure A-1.	Overscan Compensation, 640x480 NTSC, 20 Clock Hblank	A-2
Figure A-2.	Overscan Compensation, 640x480 PAL, 20 Clock Hblank	A-3
Figure A-3.	Overscan Compensation, 800x600 NTSC	A-4
Figure A-4.	Overscan Compensation, 800x600 PAL	A-5

List of Tables

Table 1-1.	Pin Assignments	1-2
Table 1-2.	Data Pin Assignments for Multiplexed Modes	1-5
Table 1-3.	Data Pin Assignments for Non-multiplexed Modes	1-5
Table 1-4.	Programmability and Frequency Requirement	1-6
Table 1-5.	Auto-Configuration Modes 0–3—RGB Input	1-11
Table 1-6.	Auto-Configuration Modes 4–7—YCrCb Input	1-12
Table 1-7.	Video Modes	1-17
Table 1-8.	Video Levels	1-18
Table 2-1.	Register Bit Map	2-1
Table 2-2.	Read-Back Bit Map	2-4
Table 2-3.	Data Details Defined	2-4
Table 2-4.	Programming Detail	2-4
Table 3-1.	Typical Parts List for Key Passive Components	3-3
Table 4-1.	Recommended Operating Conditions	4-1
Table 4-2.	Absolute Maximum Rating	4-1
Table 4-3.	DC Characteristics	4-2
Table 4-4.	AC Characteristics	4-4
Table A-1.	Video Formats	A-1
Table A-2.	Constant Values Dependent on Encoding Mode	A-2
Table A-3.	Overscan Values, 640x480 NTSC, 1 Pixel Resolution, 2.5 ms Hblank	A-5
Table A-4.	Overscan Values, 640x480 NTSC, 8 Pixel Resolution, 2.5 ms Hblank	A-7
Table A-5.	Overscan Values, 640x480 NTSC, 9 Pixel Resolution, 2.5 ms Hblank	A-8
Table A-6.	Overscan Values, 640x480 PAL, 1 Pixel Resolution, 2.5 ms Hblank	A-8
Table A-7.	Overscan Values, 640x480 PAL, 8 Pixel Resolution, 2.5 ms Hblank	A-11
Table A-8.	Overscan Values, 640x480 PAL, 9 Pixel Resolution, 2.5 ms Hblank	A-12
Table A-9.	Overscan Values, 800x600 NTSC	A-13
Table A-10.	Overscan Values, 800x600, PAL, > 2.5 ms Hblank	A-17

1.0 Functional Description

1.1 Pin Descriptions

The pinout diagram is shown in [Figure 1-1](#). Pin names, input/output assignments, numbers and descriptions are listed in [Tables 1-2](#) and [1-3](#).

Figure 1-1. Pinout Diagram

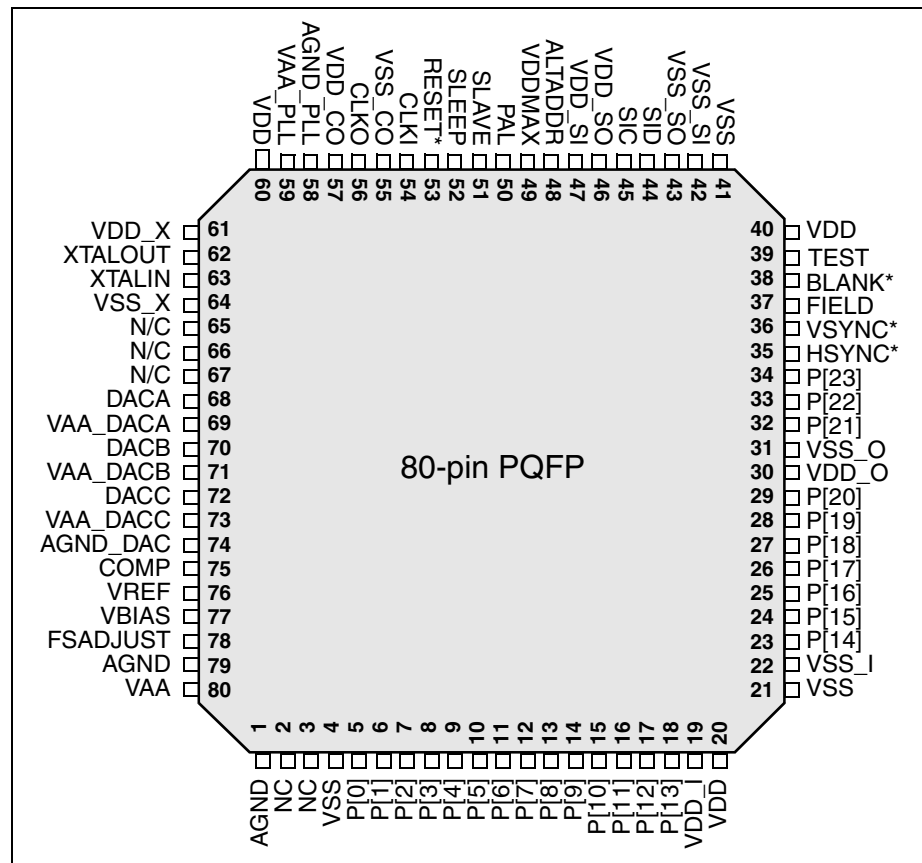

Table 1-1. Pin Assignments (1 of 3)

Pin Name	I/O	Pin #	Description
XTALIN	I	63	A crystal can be connected to these pins. The pixel clock output (CLKO) is derived from these pins with a PLL. XTALIN can be driven as a CMOS input pin.
XTALOUT	O	62	
VDD_X	—	61	Crystal oscillator supply pin. This pin should be tied to the digital supply.
VSS_X	—	64	Crystal oscillator ground pin. This pin should be tied to the digital ground plane.
VAA_PLL	—	59	Analog power for PLL. All VAA and VDD pins must be connected together on the same PCB plane to prevent latchup.
AGND_PLL	—	58	Analog ground for PLL. All AGND and VSS pins must be connected together on the same PCB plane to prevent latchup.
CLKO	O	56	Pixel clock output (TTL compatible). This pin is three-state if the CLKI pin provides the encoder clock.
VDD_CO	—	57	Clock output supply pin. This pin should be tied to the digital supply.
VSS_CO	—	55	Clock output ground pin. This pin should be tied to the digital ground plane.
CLKI	I	54	Pixel clock input (TTL compatible). This may be used as either the encoder clock or a delayed version of the CLKO pin synchronized with the pixel data input.
RESET*	I	53	Reset control input (TTL compatible). A logical 0 resets and disables video timing (horizontal, vertical, subcarrier counters to the start of VSYNC of first field) and resets the serial interface registers). RESET* must be a logical 1 for normal operation.
SLEEP	I	52	Power-down control input (TTL compatible). A logical 1 configures the device for power-down mode. A logical 0 configures the device for normal operation.
SLAVE	I	51	Slave/master mode select input (TTL compatible). A logical 1 configures the device for slave video timing operation. A logical 0 configures the device for master video timing operation.
PAL	I	50	PAL/NTSC mode select input (TTL compatible). A logical 1 configures the device for PAL video format and Mode 1. A logical 0 configures the device for NTSC video format and Mode 0.
VDDMAX	I	49	Input threshold adjustment. This pin should be tied to VDD for 3.3 V input swings and GND for 5 V input swings. This pin does not affect the serial interface pins (SID and SIC).
ALTADDR	I	48	Alternate slave address input (TTL compatible). A logical 0 configures the device to respond to a serial programming address of 0x88; a logical 1 configures the device to respond to a serial programming address of 0x8A. ⁽¹⁾
SIC	I	45	Serial interface clock input (TTL compatible). The maximum clock rate is 400 kHz.
SID	I/O	44	Serial interface data input/output (TTL compatible). Data is written to and read from the device via this serial bus.
VDD_SI	—	47	Serial interface input supply pin. This pin should be tied to the proper supply voltage for the desired serial interface operating voltage (i.e., tie to 5 V for 5 V serial interface compatibility).

Table 1-1. Pin Assignments (2 of 3)

Pin Name	I/O	Pin #	Description
VSS_SI	—	42	Serial interface input ground pin. This pin should be tied to the digital ground plane.
VDD_SO	—	46	Serial interface output supply pin. This pin should be tied to the proper supply voltage for the desired serial interface operating voltage (i.e., tie to 5 V for 5 V serial interface compatibility).
VSS_SO	—	43	Serial interface output ground pin. This pin should be tied to the digital ground plane.
TEST	I	39	Test pin. Should be tied to VSS.
BLANK*	I/O	38	Composite blanking control (TTL compatible). This can be generated by the encoder or supplied from the graphics controller. If internal blanking is used, this pin can be used to indicate the controller character clock edge.
FIELD	0	37	Field control output (TTL compatible) (Master Mode only three-state in slave mode). FIELD transitions after the rising edge of CLK, two clock cycles following falling HSYNC*. It is a logical 0 during odd fields and is a logical 1 during even fields.
VSYNC*	I/O	36	Vertical sync input/output (TTL compatible). As an output (master mode operation), VSYNC* is output following the rising edge of CLK. As an input (slave mode operation), VSYNC* is registered on the rising edge of CLK.
HSYNC*	I/O	35	Horizontal sync input/output (TTL compatible). As an output (master mode operation), HSYNC* is output following the rising edge of CLK. As an input (slave mode operation), HSYNC* is registered on the rising edge of CLK.
P[23:0]	I	32–34, 23–29, 5–18	Pixel inputs. See Table 1-2, “Data Pin Assignments for Multiplexed Modes,” on page 1.05 . The input data is sampled on both the rising and falling edge of CLK for multiplexed modes, and on the rising edge of clock in non-multiplexed modes. A higher bit index corresponds to a greater bit significance.
VDD	—	20,40,60	Digital power for core logic. All VAA and VDD pins must be connected together on the same PCB plane to prevent latchup.
VDD_I	—	19	Digital power for digital inputs. All VAA and VDD pins must be connected together on the same PCB plane to prevent latchup. This pin should be tied to the 5 V supply for 5 V tolerant inputs,
VDD_O	—	30	Digital power for digital outputs. All VAA and VDD pins must be connected together on the same PCB plane to prevent latchup.
VSS	—	4, 21, 41	Digital ground for core logic. All AGND and VSS pins must be connected together on the same PCB plane to prevent latchup.
VSS_I	—	22	Digital ground for inputs. All AGND and VSS pins must be connected together on the same PCB plane to prevent latchup.
VSS_O	—	31	Digital ground for outputs. All AGND and VSS pins must be connected together on the same PCB plane to prevent latchup.
VAA	—	80	Analog power. All VAA and VDD pins must be connected together on the same PCB plane to prevent latchup.
AGND	—	1, 79	Analog ground. All AGND and VSS pins must be connected together on the same PCB plane to prevent latchup.

Table 1-1. Pin Assignments (3 of 3)

Pin Name	I/O	Pin #	Description
FSADJUST	I	78	Full-scale adjust control pin. A resistor (RSET) connected between this pin and GND controls the full-scale output current on the analog outputs.
VBIAS	0	77	DAC bias voltage. A 0.1 μ F ceramic capacitor must be used to bypass this pin to GND. The capacitor must be as close to the device as possible to keep lead lengths to an absolute minimum.
VREF	0	76	Voltage reference pin. A 0.1 μ F ceramic capacitor must be used to decouple this pin to GND. The decoupling capacitor must be as close to the device as possible to keep lead lengths to an absolute minimum.
COMP	0	75	Compensation pin. A 0.1 μ F ceramic capacitor must be used to bypass this pin to VAA. The capacitor must be as close to the device as possible to keep lead lengths to an absolute minimum.
AGND_DAC	—	74	Common DAC Analog ground return. All AGND and VSS pins must be connected together on the same PCB plane to prevent latchup.
VAA_DACC	—	73	DACC Analog power. All VAA and VDD pins must be connected together on the same PCB plane to prevent latchup.
DACC	0	72	DACC output.
VAA_DACB	—	71	DACB Analog power. All VAA and VDD pins must be connected together on the same PCB plane to prevent latchup.
DACB	0	70	DACB output.
VAA_DACA	—	69	DACA Analog power. All VAA and VDD pins must be connected together on the same PCB plane to prevent latchup.
DACA	0	68	DACA output.
N/C	—	65, 66, 67	No connect pins
NOTE(S): (1) Any unused inputs should not be left floating.			

Table 1-2. Data Pin Assignments for Multiplexed Modes

Pin	Rising Edge of CLKI				Falling Edge of CLKI			
	24-bit RGB Mode	15/16-bit RGB Mode	16-bit YCrCb Mode	24-bit YCrCb Mode	24-bit RGB Mode	15/16-bit RGB Mode	16-bit YCrCb Mode	24-bit YCrCb Mode
P[11]	G4	G2	Cr/Cb7	Cr7	R7	R4	Y7	Y7
P[10]	G3	G1	Cr/Cb6	Cr6	R6	R3	Y6	Y6
P[9]	G2	G0	Cr/Cb5	Cr5	R5	R2	Y5	Y5
P[8]	B7	B4	Cr/Cb4	Cr4	R4	R1	Y4	Y4
P[7]	B6	B3	Cr/Cb3	Cr3	R3	R0	Y3	Y3
P[6]	B5	B2	Cr/Cb2	Cr2	G7	G5 ⁽¹⁾	Y2	Y2
P[5]	B4	B1	Cr/Cb1	Cr1	G6	G4	Y1	Y1
P[4]	B3	B0	Cr/Cb0	Cr0	G5	G3	Y0	Y0
P[3]	G0	—	—	Cb7	R2	—	—	Cb3
P[2]	B2	—	—	Cb6	R1	—	—	Cb2
P[1]	B1	—	—	Cb5	R0	—	—	Cb1
P[0]	B0	—	—	Cb4	G1	—	—	Cb0

NOTE(S):
⁽¹⁾ G5 is ignored in 15-bit RGB mode.

Table 1-3. Data Pin Assignments for Non-multiplexed Modes

Pin	24-bit RGB Mode	24-bit YCrCb Mode
P[23:16]	B[7:0]	Cb[7:0]
P[15:8]	G[7:0]	Cr[7:0]
P[7:0]	R[7:0]	CY[7:0]

1.2 GUI Controller Programmability and Frequency Requirement

Programmability and frequency requirements for the GUI Controller are defined in [Table 1-4](#).

Table 1-4. Programmability and Frequency Requirement

Mode	Maximum Total		Maximum Vsync to Active	Maximum Frequencies	
	Pixels	Lines		Line (kHz)	Pixel (MHz)
640 x 480	1075	665	117	39.860	31.563
800 x 600	1075	835	147	49.451	40.000

Figure 1-2 illustrates the concept of flicker filter control.

Figure 1-2. Flicker Filter Control Diagram—External Use

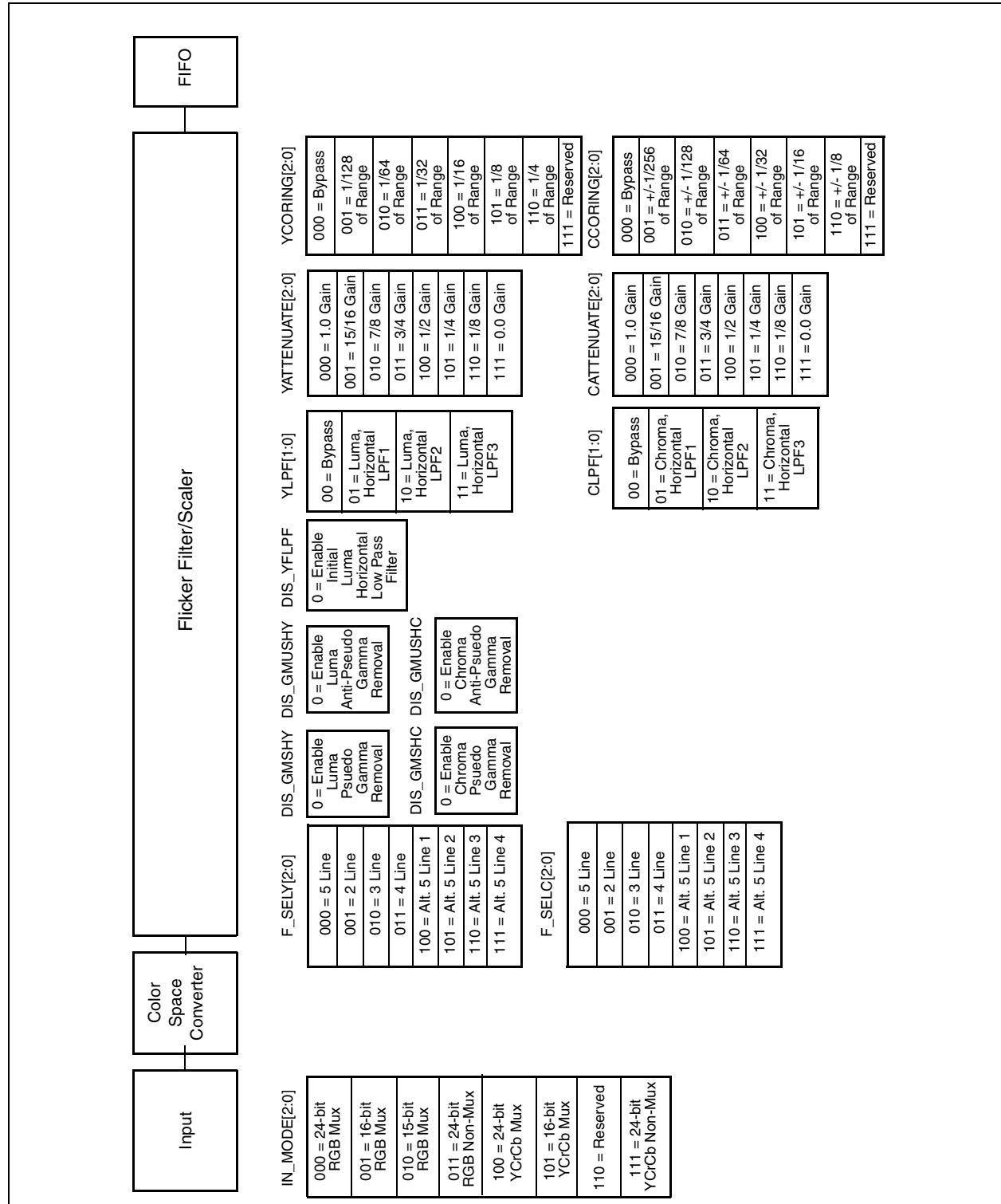
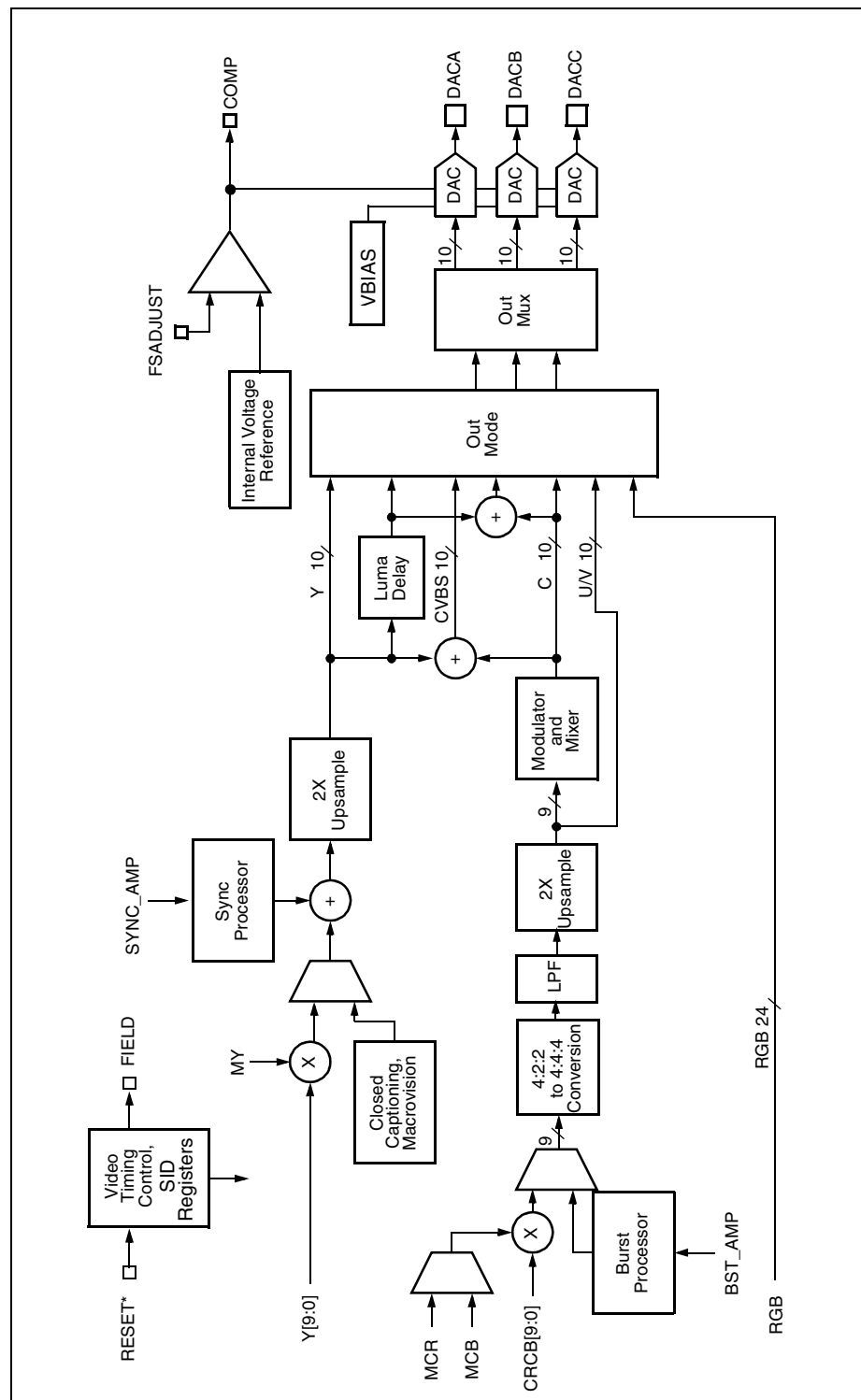

Figure 1-3 illustrates the Bt868/869 functional block diagram.

Figure 1-3. Encoder Core



1.3 Circuit Description

1.3.1 Overview

The Bt868/869 is a video encoder designed for TV output of non-interlaced graphics data, such as that found in a PC or some set-top boxes. It incorporates advanced filtering technology for flicker removal and overscan compensation which allows high-quality display of non-interlaced images on an interlaced TV display. The Bt868/869 accomplishes this by minimizing the flicker and providing control of the amount of overscan so that the entire image is viewable.

The Bt868/869 consists of a Color Space Converter/Flicker Filter engine followed by a digital video encoder. The Color Space Converter/Flicker Filter contains the following:

- A timing converter
- Various horizontal video processing functions
- Flicker filter and vertical scaler for overscan compensation

The output of this engine is fed into a FIFO for synchronization with the digital video encoder.

1.3.2 Reset

If the RESET* pin is held low for a minimum of two clock cycles, a timing reset and a software reset is performed. During a timing reset, the serial interface is held in the reset condition, the subcarrier phase is set to zero, and the horizontal and vertical counters are held to the beginning of VSYNC of Field 1 (both counters equal to zero). Counting resumes the next clock after rising RESET*. The serial interface registers are reset to zero.

A software reset, which can be generated by setting the SRESET register bit, initializes all the serial interface registers to zero (except for PLL_INT, which is initialized to 0x0C). As a result, all output pins are three-state. The first 32 registers are then initialized to auto-configuration mode 0 (see the Auto Configuration section). The EN_OUT bit must be set to enable the outputs. The software reset can also be generated by setting the SRESET register bit.

A power-on reset is generated on power-up. The power-on reset generates both a timing and a software reset. The power-on reset is generated by a time delay circuit triggered after the supply voltage reaches a value sufficiently high enough for the circuit to operate. As such, the device may not initialize to the default state unless the power supply ramp rate is sufficiently fast enough. Therefore, a hardware reset is recommended if the default state is required.

1.3.3 Timing Registers

After writing any registers, a timing reset is recommended by setting the T-bit.

1.3.4 Device Initialization

After a reset condition, the device must be programmed through the serial interface to activate video or output one of the other video standards and to enable the CLK0, HSYNC*, VSYNC*, and FIELD outputs.

1.3.5 Auto Configuration

The device can configure itself for one of eight combinations of video formats and input modes with a single register write. Tables 1-5 and 1-6 detail the eight available auto configuration modes. This feature reduces the software support required, yet allows full flexibility in generating video formats and timing. Once the device is configured, all the registers are accessible to modify the modes. For less common modes, the device can be configured for the closest mode, and only those registers that differ need to be programmed. To auto-configure the device, set the configuration bits (CONFIG[2:0]) to the desired mode. The device will initialize the first 32 registers (registers 0x3B to 0x5A), setting the BUSY flag in the process. When complete, the BUSY flag is cleared. The serial interface is not available when the BUSY flag is high except for monitoring the status register.

If the mux mode is enabled, pins P[23:21] can also be used to externally configure the device to any one of the eight configuration modes. These pins directly emulate the CONFIG[2:0] register. In order to configure the device in this way, the EN_PINCFG register must be set. The desired state must be present on the P[23:21] pins for at least two clock cycles.

Table 1-5. Auto-Configuration Modes 0–3—RGB Input (1 of 2)

Register Name	Mode 0 NTSC 640x480 ⁽¹⁾ CLKO=28.195793 MHz		Mode 1 PAL 640x480 CLKO=29.500008 MHz		Mode 2 NTSC 800x600 CLKO=38.769241 MHz		Mode 3 PAL 800x600 CLKO=36.000000 MHz	
	DEC	HEX	DEC	HEX	DEC	HEX	DEC	HEX
H_CLKO [11:0]	1792	700	1888	760	2464	9A0	2304	900
H_ACTIVE [9:0]	640	280	640	280	800	320	800	320
HSYNC_WIDTH [7:0]	132	84	138	8A	182	B6	170	AA
HBURST_BEGIN [7:0]	150	96	166	A6	206	CE	202	CA
HBURST_END [7:0]	96	60	104	68	180	84	154	9A
H_BLANKO [10:0]	381	17D	449	1C1	597	255	525	20D
V_BLANKO [9:0]	34	22	46	2E	32	20	41	29
V_ACTIVEO [8:0]	212	D4	242	F2	216	D8	252	FC
H_FRACT [7:0]	0	0	0	0	0	0	0	0
H_CLKI [10:0]	784	310	944	3B0	880	370	960	3C0
H_BLANKI [8:0]	126	7E	266	10A	66	42	140	8C
V_BLANK_DLY	0	0	0	0	0	0	0	0
V_LINESI [9:0]	600	258	625	271	735	2DF	750	2EE
V_BLANKI [7:0]	75	4B	90	5A	86	56	95	5F
V_ACTIVEI [9:0]	480	1E0	480	1E0	600	258	600	258
CLPF [1:0]	0	0	0	0	0	0	0	0
YLPF [1:0]	3	3	3	3	3	3	3	3
V_SCALE [13:0]	5266	1492	4096	1000	7373	1CCD	5734	1666
PLL_FRACT [15:0]	34830	880E	7282	1C72	15124	3B14	0	0
EN_XCLK	0	0	0	0	0	0	0	0
BY_PLL	0	0	0	0	0	0	0	0
PLL_INT [5:0]	12	C	13	D	17	11	16	10
EN_SCART	0	0	0	0	0	0	0	0
ECLIP	0	0	0	0	0	0	0	0
PAL	0	0	1	1	0	0	1	1
DIS_SCRESET	0	0	0	0	0	0	0	0
VSYNC_DUR	1	1	0	0	1	1	0	0
625LINE	0	0	1	1	0	0	1	1
SETUP	1	1	0	0	1	1	0	0

Table 1-6. Auto-Configuration Modes 4–7—YCrCb Input (2 of 2)

Register Name	Mode 4 NTSC 640x480 CLKO=28.195793 MHz		Mode 5 PAL 640x480 CLKO=29.500008 MHz		Mode 6 NTSC 800x600 CLKO=38.769241 MHz		Mode 7 PAL 800x600 CLKO=36.000000 MHz	
	DEC	HEX	DEC	HEX	DEC	HEX	DEC	HEX
YLPF [1:0]	3	3	3	3	3	3	3	3
V_SCALE [13:0]	5266	1492	4096	1000	7373	1CCD	5734	1666
PLL_FRACT [15:0]	34830	880E	7282	1C72	15124	3B14	0	0
EN_XCLK	0	0	0	0	0	0	0	0
BY_PLL	0	0	0	0	0	0	0	0
PLL_INT [5:0]	12	C	13	D	17	11	16	10
EN_SCART	0	0	0	0	0	0	0	0
ECLIP	0	0	0	0	0	0	0	0
PAL	0	0	1	1	0	0	1	1
DIS_SCRESET	0	0	0	0	0	0	0	0
VSYNC_DUR	1	1	0	0	1	1	0	0
625LINE	0	0	1	1	0	0	1	1
SETUP	1	1	0	0	1	1	0	0
NI_OUT	0	0	0	0	0	0	0	0
SYNC_AMP [7:0]	229	E5	240	F0	229	E5	240	F0
BST_AMP [7:0]	118	76	88	58	116	74	87	57
MCR [7:0]	121	79	129	81	119	77	128	80
MCB [7:0]	68	44	73	49	67	43	72	48
MY [7:0]	133	85	140	8C	133	85	140	8C
MSC [31:0]	545259520	20800000	645499916	26798C0C	396552378	17A2E8BA	528951320	1F872818

1.3.6 Clocking and Timing Generation

There are two timing generators that control the operation of the encoder. The encoder timing block generates the signals for the proper encoding of the video into NTSC or PAL, and extracts the processed input pixels from the internal FIFO. The encoding timing generator can receive its clock from either an external crystal oscillator and PLL, or from the CLKI pin. Normal operation requires that the encoding clock be generated by the PLL. The clock source is selected by the EN_XCLK register bit. If EN_XCLK is set to a logical 0, the internal clock source is selected; and when the EN_OUT bit is set, the CLKO pin is enabled to drive the derived clock.

A crystal must be present between XTALIN and XTALOUT pins if the internal clock source is selected. The frequency of the CLK is synthesized by a PLL such that the frequency is:

$$F_{clk} = F_{xtal} * \{PLL_INT(5:0) + [PLL_FRACT(15:0)/216]\}/6$$

The crystal must be chosen so that the precise line rate for the video standards required can be achieved. This is done to maintain the subcarrier relationship to the line rate and thereby achieve the precise subcarrier frequency as required by the standard. The crystal oscillator is designed to oscillate from 5-25 MHz. A 13.5 MHz crystal meets the requirements for both NTSC and PAL video standards. The crystal must be within 50 ppm of the maximum desired clock rate for NTSC operation, and 25 ppm for PAL operation, across temperature (0° to 70°C). See Appendix B for list of recommended crystal vendors.

The crystal oscillator is disabled by the SLEEP pin. Sufficient time (greater than approximately 1 second) must be allowed after coming out of sleep mode to allow the oscillator to stabilize.

If the external clock source is selected (EN_XCLK=1), a clock signal of the desired pixel clock rate must be present at the CLKI pin. The CLKO pin will be three-state, and the crystal oscillator disabled. The clock must meet the same requirements as above. It is highly recommended that the internal clock be used in order to ensure that the output video remain within the specifications defined by the relevant video standard. Any aberration in the source clock is reflected in the output video and detracts from the quality of the image.

The BY_PLL bit will bypass the PLL, and the encoder clock will be at the crystal frequency. This bit will take precedence over the EN_XCLK bit.

The second timing generator controls the generation of the HSYNC*, VSYNC*, BLANK*, and pixel input clocking. This is normally the same clock as the encoding clock. The EN_ASYNC register bit, if set, will allow this clock to be driven directly by the CLKI pin. If the DIV2 register bit is set, this internal clock is divided by two before driving the second timing generator. This is required for interlaced input to interlaced output mode (i.e., CCIR601 applications).

The CLKI pin is the clock used for synchronizing the pixel inputs (P[23:0]) and any timing input signals (HSYNC*, VSYNC*, and BLANK*) and normally must be a delayed version of the CLKO pin. It can be directly connected to CLKO if desired. Data is registered with this input and re-synchronized to the internal clock. Normally, in muxed input mode, both edges of the CLKI input are used. If the MODE2X register bit is set, the internal clock is divided by two, allowing a 2x external clock, and the data to be provided on the rising edge only.

1.3.7 Master and Slave Modes

The device can operate as either a timing master or a slave. In master mode, the device will generate and output HSYNC*, VSYNC*, and BLANK*. In slave mode, these must be provided externally. The desired mode is selected by the SLAVE pin and SLAVER bit.

It is highly recommended that the device operate as a master, to ensure that the input and output video streams remain synchronized. If the device supplying the HSYNC* and VSYNC* inputs in slave mode is not correctly programmed, or the timing varies from that which is required, the output image will lose lock with the input. By running the device in master mode, any timing errors that occur can be absorbed to some extent by the on-board FIFO.

1.3.8 Input Formats

The device can convert a wide range of input formats to television video formats. The input format can be either non-interlaced computer video in 640 x 480 or 800 x 600 formats, or interlaced formats such as CCIR601 formats as well as most other formats which might be encountered. For detailed information on the CCIR601 mode, please refer to the “DVD Movie Playback Architecture and Solutions Application Note”. This application note may be obtained from your local Conexant Semiconductor sales office.

1.3.9 Pixel Input Timing

The device can accept the input in data either RGB or YCrCb color spaces. Data can be input either a full pixel at a time, clocked in on the rising edge of CLKI, or in various multiplexed modes, using both edges of CLKI.

In YCrCb mode, either 24-bit 4:4:4 data or 16-bit 4:2:2 data can be input. In RGB mode, either 15 bit 5:5:5, 16 bit 5:6:5, or 24-bit RGB can be input. In 16-bit 4:2:2 YCrCb input mode, multiplexed Y, Cr, and Cb data is input through the P[11:4] inputs. The Y data is input on the falling edge of CLK. The Cr/Cb data is input on the rising edge of CLK. The Cb/Y/Cr/Y sequence begins at the first active pixel. In 24-bit 4:4:4 YCrCb input mode, multiplexed Y, Cr, and Cb data is input through the P[11:0] inputs. The input data is sampled on both the rising and falling edge of CLK. In RGB input mode, input data is sampled as 12 bits in 24-bit RGB mode or 8 bits in 15/16 bit RGB mode on both the rising and falling edge of CLK. [Table 1-2](#) shows the assignments of input P[11:0] data on rising edge and falling edge of CLK.

In addition, all 24-bit modes can utilize a non-multiplexed mode. See [Table 1-3 on page 1-5](#).

1.3.10 Output Modes

The encoder can generate the video as Composite/Y-C, as YUV component, or as VGA-style RGB. These modes are selected by the OUT_MODE[1:0] register bits.

When outputting RGB, the device will output VGA/SVGA analog RGB. In this mode, the R, G, and B input data is fed to the DACs after the addition of sync and, if the SETUP bit is set, setup. The output currents are scaled so that the DACs output the proper 1 V full-scale levels for driving a monitor. The graphics controller provides all the timing control for the monitor, and the device operates as a slave. Only the P[23:0], BLANK*, HSYNC*, and VSYNC* input pins and the RGB analog output pins are active. The BLANK*, HSYNC*, and VSYNC* pins are automatically enabled as inputs in this mode.

Each of the three video signals generated by the OUT_MODE bits can be multiplexed to any DAC using the OUT_MUXA[1:0], OUT_MUXB[1:0], and OUT_MUXC[1:0] register bits.

1.3.11 YCrCb Inputs

Y has a nominal range of 16–235; Cb and Cr have a nominal range of 16–240, with 128 equal to zero. Values of 0 and 255 are interpreted as 1 and 254, respectively. Y values of 1–15 and 236–254, and CrCb values of 1–15 and 241–254, are interpreted as valid linear values.

Figure 1-4 shows the frequency response of the sub-sampling process. If 4:4:4 data is input, it is sub-sampled to 4:2:2 prior to overscan compensation and flicker filtering.

Figure 1-4. Decimation Filter at $F_s=27$ MHz

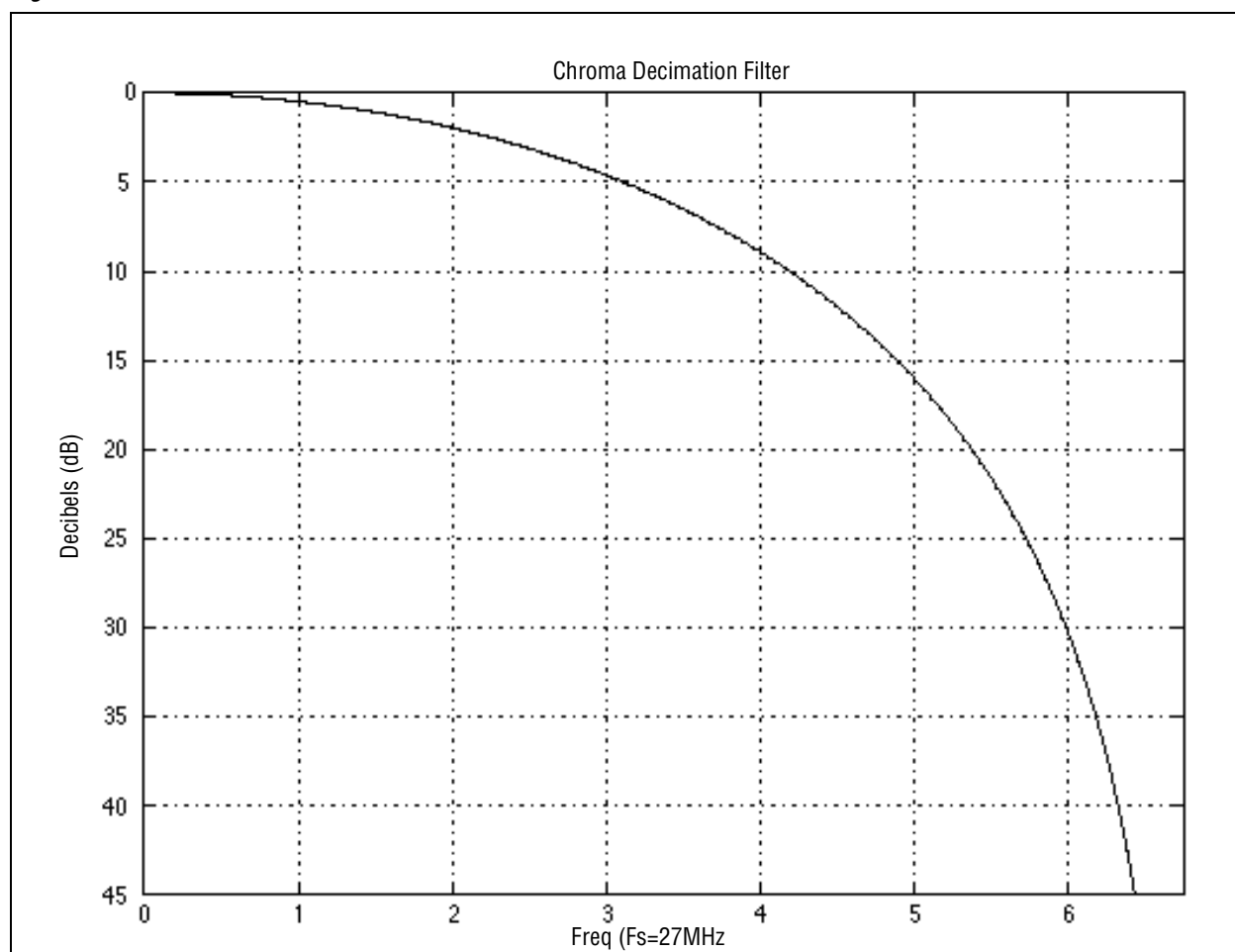

The resulting 4:2:2 output must then be converted to YUV values and then scaled for the output range of the DACs. The MY, MCR, and MCB registers must be programmed to perform this conversion. The scaling equations are as follows:

$$MY = (\text{int}) [V_{100}/(219.0 * V_{FS}) * 2^6 + 0.5]$$

$$MCR = (\text{int}) [(128.0/127.0) * V_{100} * 0.877 / (224.0 * V_{FS} * 0.713 * \sin x) * 2^6 + 0.5]$$

$$MCB = (\text{int}) [(128.0/127.0) * V_{100} * 0.493 / (224.0 * V_{FS} * 0.564 * \sin x) * 2^6 + 0.5]$$

where: V_{100} = 100% white voltage (0.661 V for NTSC, 0.7 V for PAL)

V_{FS} = Full scale output voltage (1.28 V)

$\text{SINX} = \text{SIN} (2\pi F_{SC}/F_{CLK}) / (2\pi F_{SC}/F_{CLK})$

1.3.12 RGB Inputs

With IN_MODE set to 24, 16, or 15-bit RGB mode, digital, gamma-corrected RGB data with a 0-255 range is input via the P[11:0] inputs in 24-bit RGB mode or P[11:4] inputs in 15/16-bit RGB mode on both the rising and falling edge of CLK. The RGB data is converted to Y/R-Y/B-Y as follows:

$$Y[9:0] = [INT(.299 * 2^{10}) * R[7:0] + INT(.587 * 2^{10}) * G[7:0] + INT(.114 * 2^{10}) * B[7:0] = 2^7] * 2^{-8}, 0 \text{ to } 1024$$

The Y/R-Y/B-Y values are then sub-sampled to 4:2:2 data prior to overscan compensation and flicker filtering.

The resulting 4:2:2 output must then be converted to YUV values and then scaled for the output range of the DACs. The MY, MCR, and MCB registers must be programmed to perform this conversion. The scaling equations are as follows:

$$MY = (int)[V_{100}/(255 * V_{FS}) * 2^6 + 0.5]$$

$$MCR = (int)[(128.0/127.0) * V_{100} * 0.877 / (127 * V_{FS} * \sin x) * 2^5 + 0.5]$$

$$MCB = (int)[(128.0/127.0) * V_{100} * 0.493 / (127 * V_{FS} * \sin x) * 2^5 + 0.5]$$

where: V_{100} = 100% white voltage (0.661 V for NTSC, 0.7 V for PAL)

V_{FS} = Full scale output voltage (1.28 V)

$SINX = \sin(2\pi F_{SC}/F_{CLK}) / (2\pi F_{SC}/F_{CLK})$

1.3.13 Video Amplitude Scaling

Both the luminance and chrominance video amplitudes can be scaled by the MCR, MCB, and MY registers. This allows various colormetry standards to be achieved, and can also be used to boost the chroma to compensate for the $\sin X/X$ loss of the DACs. Tables 1-7 and 1-8 show the range of values achievable and values for various video formats.

Table 1-7. Video Modes

Mode	NTSC	NTSC-Japan	PAL-BDGH	PAL-N	PAL-Nc	PAL-M	PAL-60
VSYNC_DUR	1	1	0	1	0	1	1
625LINE	0	0	1	1	1	0	0
SETUP	1	0	0	1	0	1	0
PAL	0	0	1	1	1	1	1

Table 1-8. Video Levels

Mode		Range	NTSC	NTSC-Japan	PALBDGHI	PAL-N	PAL-Nc	PAL-M	PAL-60
100% White Amp (V)			0.661	0.714	0.7	0.661	0.7	0.661	0.7
Sync Amp (V)			0.286	0.286	0.301	0.286	0.301	0.286	0.301
Subcarrier Amp (V)			0.286	0.286	0.3	0.3	0.3	0.306	0.306
YCrCb Input	MY	0-255	153	158	158	153	158	153	158
	MCR	0-255	187	207	207	187	207	187	207
	MCB	0-255	133	149	149	133	149	133	149
RGB Input	MY	0-255	133	143	141	133	141	133	141
	MCR	0-255	117	127	124	117	124	117	124
	MCB	0-255	66	71	70	66	70	66	70
SYNC_AMP		0-255	225	225	238	225	238	225	238
BST_AMP		0-255	114	114	90	90	90	92	92

1.3.14 Input Pixel Horizontal Sync

The HSYNC* pin provides the pixel synchronization for the pixel input data. It is an output in master mode, and an input in slave mode. In master mode, it is a pulse two CLK cycles in duration whose leading edge indicates the beginning of a new line of pixel data. The period of the pulses is H_CLKI CLK cycles. The first pixel should be presented to the device H_BLANKI minus the internal pipelined clock (in CLK cycles) after a leading edge of HSYNC*. The next H_ACTIVE pixels will be accepted as active pixels and used in the construction of the output video. In slave mode, the period must be exactly the number of clocks required for the desired overscan mode. Only the leading edge is used, and the high and low times must be at least two CLK cycles in duration. HSYNC* is clocked by the rising edge of CLKI. HSYNCI is clocked by the rising edge of CLKI.

The polarity of the HSYNC* pin can be programmed by the HSYNCI register bit. The default convention is active low.

1.3.15 Input Pixel Vertical Sync

The VSYNC* pin provides the line synchronization for the pixel input data. It is an output in master mode, and an input in slave mode.

For non-interlaced input timing in master mode, VSYNC* is a pulse one horizontal line time in duration whose leading edge indicates the beginning of a frame of input pixel data. The leading edge coincides with the leading edge of HSYNC*. The period of the pulses is V_LINESI horizontal lines. The first line of data should be presented to the device V_BLANKI lines after the leading edge of VSYNC*. The next V_ACTIVEI lines are accepted as active lines and used in the construction of the output video. In slave mode, the period must be exactly the frame rate of the desired video format. Only the leading edge is used, and the high and low duration must be at least two CLK cycles. The beginning of the frame of data is indicated by the next leading edge of HSYNC* coincident with or after the leading edge of VSYNC*.

For interlaced input timing, only slave mode is supported. The period must be exactly the frame rate of the desired video format. If the leading edge of HSYNC* and VSYNC* are coincident, which indicates the input is in odd field, the internal line counter is reset to line 1 at the leading edge of VSYNC*. If the leading edges of HSYNC* and VSYNC* are not coincident, which indicates the input is in even field, the internal line counter will be reset to line 2 at the beginning of the next line. Only the leading edge of VSYNC* is used, and the high and low duration must be at least two CLK cycles. VSYNC* is clocked by the rising edge of CLKI.

The polarity of the VSYNC* output can be programmed by the VSYNCI register bit. The default convention is active low.

1.3.16 Input Pixel Blanking

The input pixel blanking can be controlled by either the BLANK* pin or by the internal registers. It can be programmed independently of master/slave mode using the EN_BLANKO register bit. In output mode (EN_BLANKO=1), the pixel blanking is generated based on the active area defined by the H_BLANKI, H_ACTIVE, V_BLANKI, and V_ACTIVEI registers, and the BLANK* pin will be output in the proper relationship to the syncs to indicate the active pixels. In input mode (EN_BLANKO=0), when the BLANK* pin goes high, it will indicate start of active pixels at the pixel input pins. The duration of active pixel is still determined by the H_ACTIVE register. BLANK* is clocked by the rising edge of CLKI.

An additional function for the BLANK* pin is used if the EN_DOT register bit is set. In this mode, the internally-generated blanking is used. The BLANK* pin becomes an input whose rising edge defines the graphics controller character clock boundary. This is used internally by the encoder to keep track of the exact pixel count for controllers that cannot operate at pixel clock rates but instead operate at VGA character clock rates.

1.3.17 Overscan Compensation and Flicker Filtering

The resulting subsampled and optionally color-space-converted pixel data is processed by the overscan compensation and flicker filtering logic. This process converts the lines of input pixel data to the appropriate number of output lines for producing a full-screen image on the television receiver. The image, which is 100% within the viewable area of the screen (overscan compensated), can perform vertical filtering to reduce the effects of picture flicker due to the interlacing of the output image. The amount of flicker filtering is programmable, because this process trades off vertical resolution in order to reduce the flicker, and allows the process to be optimized for the image. Horizontal scaling is achieved by adjusting the encoder clock rate. No additional horizontal processing is performed on the input pixels. This allows the full bandwidth of the input image to be output, limited only by the 2x upsampling filter response, which is nominally greater than 6 MHz.

The device can accept a wide variety of input image formats, from 640x480 to 800x600, and can output all NTSC and PAL video formats.

Figures A-1 through A-4 in Appendix A show the possible ranges of overscan compensation for 640x480 and 800x600 NTSC and PAL formats, for graphics controllers with synchronization resolutions of 1, 8, and 9 pixel clocks, using a horizontal blanking interval of 20 pixel clocks. Tables A-3 through A-10 show representative values for the following:

- Input picture and frame and output picture and field sizes for 640x480 and 800x600 input picture size
- NTSC and PAL outputs using a horizontal blanking interval of 2.5 μ s.

The DIS_FFILT register bit disables the flicker filter. The vertical scaling should also be disabled by setting the VSCALE register to 4096 for non-interlaced input, or 0 for interlaced input.

CONFIG[2:0]	This field determines the configuration for the automatic configuration process.
000	= NTSC 640 x 480 RGB input
001	= PAL 640 x 480 RGB input
010	= NTSC 800 x 600 RGB input
011	= PAL 800 x 600 RGB input
100	= NTSC 640 x 480 YCrCbYCrCb input
101	= PAL 640 x 480 YCrCb input
110	= NTSC 800 x 600 YCrCb input
111	= PAL 800 x 600 YCrCb input

LUMADLY[1:0]	This 2-bit value can be used to program the luminance delay in pixels for the CVBS_DLY and Y_DLY output modes.
00	= no delay
01	= 1 pixel
10	= 2 pixels
11	= 3 pixels

1.3.18 VGA Compatibility

To achieve VGA compatibility, the controller must manipulate the VGA register settings in order to produce a consistent output timing for all VGA modes. The encoder has no way of knowing that a different VGA mode has been selected, and therefore cannot make any adjustments to the timing. The extent of VGA compatibility is entirely the controller's responsibility.

1.3.19 Analog Horizontal Sync

The duration of the horizontal sync pulse is determined by the horizontal sync width register (HSYNC_WIDTH[7:0]). The beginning of the horizontal sync pulse corresponds to the reset of the internal horizontal pixel counter. The horizontal line rate is determined by H_CLKI[11:0]. The internal horizontal counter is reset to 1 at the beginning of the horizontal sync and counts up to H_CLKI.

The sync rise and fall times are automatically controlled. The sync amplitude is programmable over a range of values by SYNC_AMP[7:0]. [Table 1-8](#) lists the range of sync values obtainable and the preferred values for various video formats.

1.3.20 Analog Vertical Sync

The duration of the vertical sync is selectable as either 2.5 or 3 lines by register bit VSYNC_DUR. If VSYNC_DUR = 0, 3 lines are selected; if VSYNC_DUR = 1, 2.5 lines are selected. The duration of the serration and equalization pulses are 1/2 the duration of the horizontal sync duration.

1.3.21 Analog Video Blanking

Analog video blanking is controlled by the H_BLANKO, V_BLANKO, and V_ACTIVEO registers. Together they define an active region where pixels will be displayed. V_BLANKO defines the number of lines from the leading edge of the analog vertical sync to the first active output lines, per field; V_ACTIVEO defines the number of active output lines. H_BLANKO defines the number of output pixels from the leading edge of horizontal sync to the first active output pixel; H_ACTIVEO defines the number of active output pixels.

The device will automatically blank the video from the start of the horizontal sync interval through the end of the burst, as well as the vertical sync to prevent erroneous video timing generation.

1.3.22 Video Standards

There are several bits (625LINE, SETUP, and VSYNC_DUR) and a PAL pin that control the generation of various video standards. (These are summarized in [Table A-1](#).) They allow the generation of all the NTSC and PAL video standards. These bits control the specific encoding process parameter, and other registers may also need to be modified to meet all the video parameters of the particular video standard. Video timing diagrams are illustrated in Figures 1-5 through 1-13, which summarize all the common video standards and the required register values for typical input formats.

Figure 1-5. Interlaced 525-Line (NTSC) Video Timing

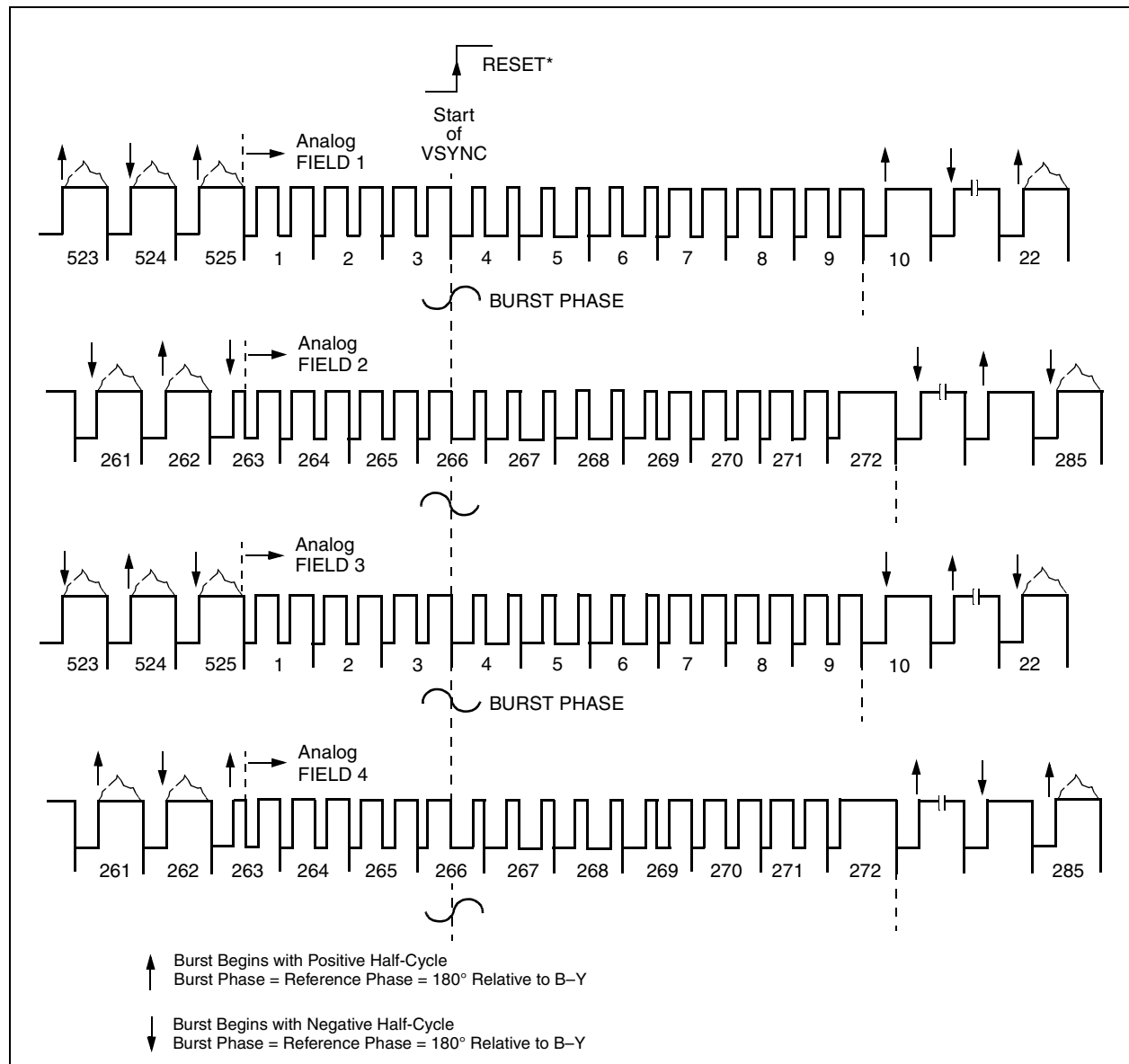

NOTE(S): SMPTE line numbering convention is used rather than CCIR624.

Figure 1-6. Interlaced 525-Line (PAL-M) Video Timing

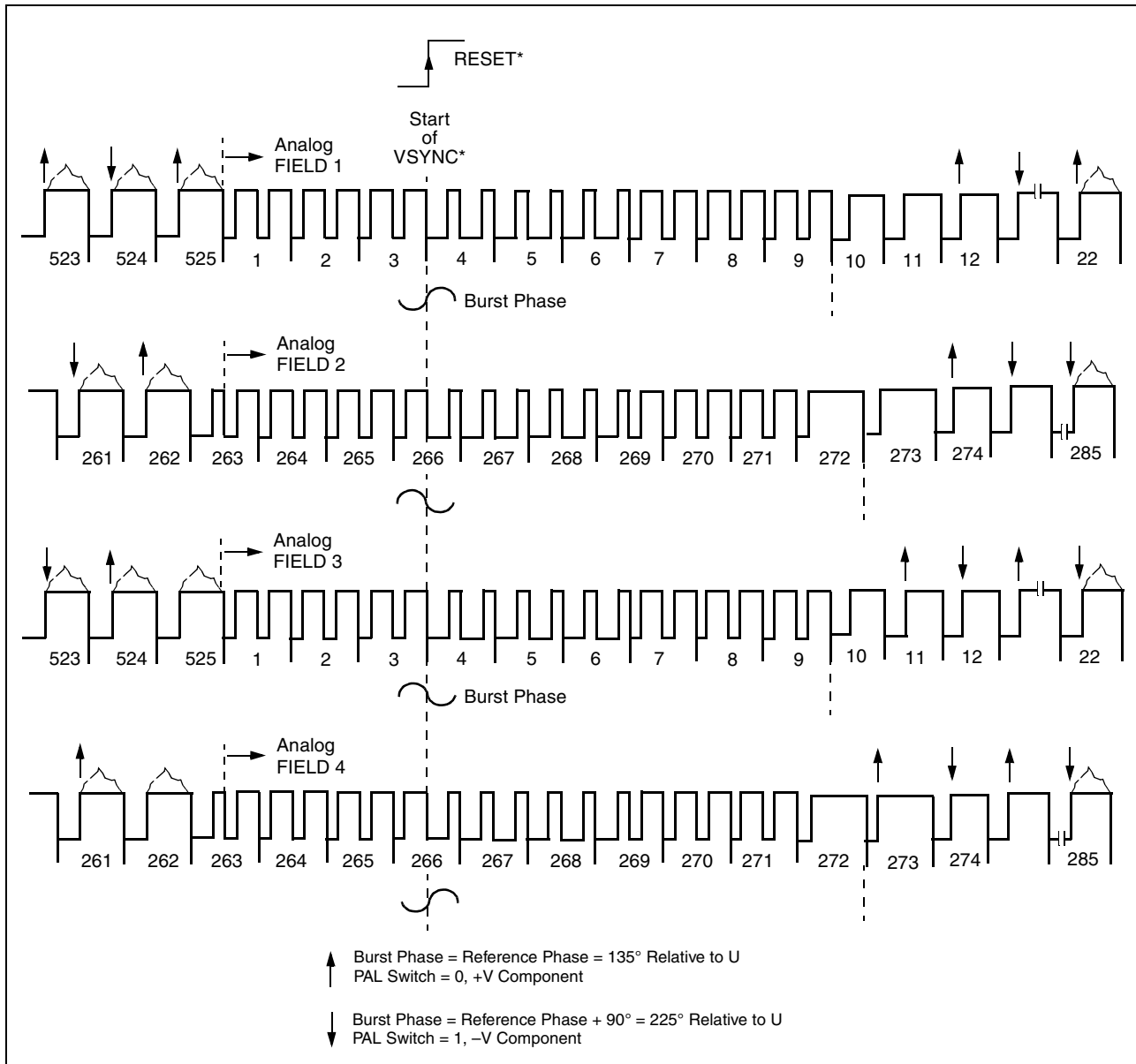

Figure 1-7. Interlaced 625-Line (PAL-B, D, G, H, I, Nc) Video Timing (Fields 1-4)

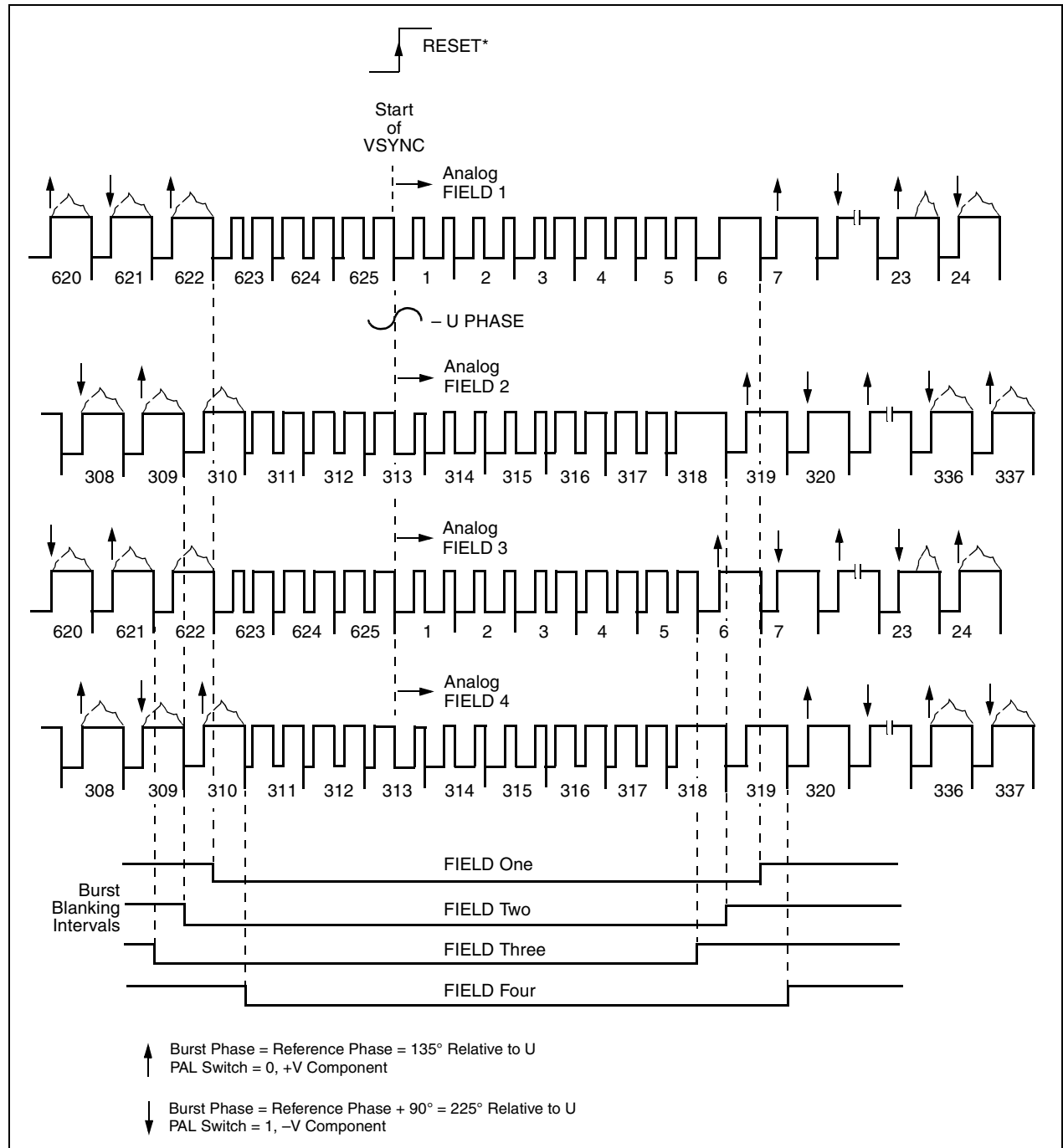

Figure 1-8. Interlaced 625-Line (PAL-B, D, G, H, I, Nc) Video Timing (Fields 5-8)

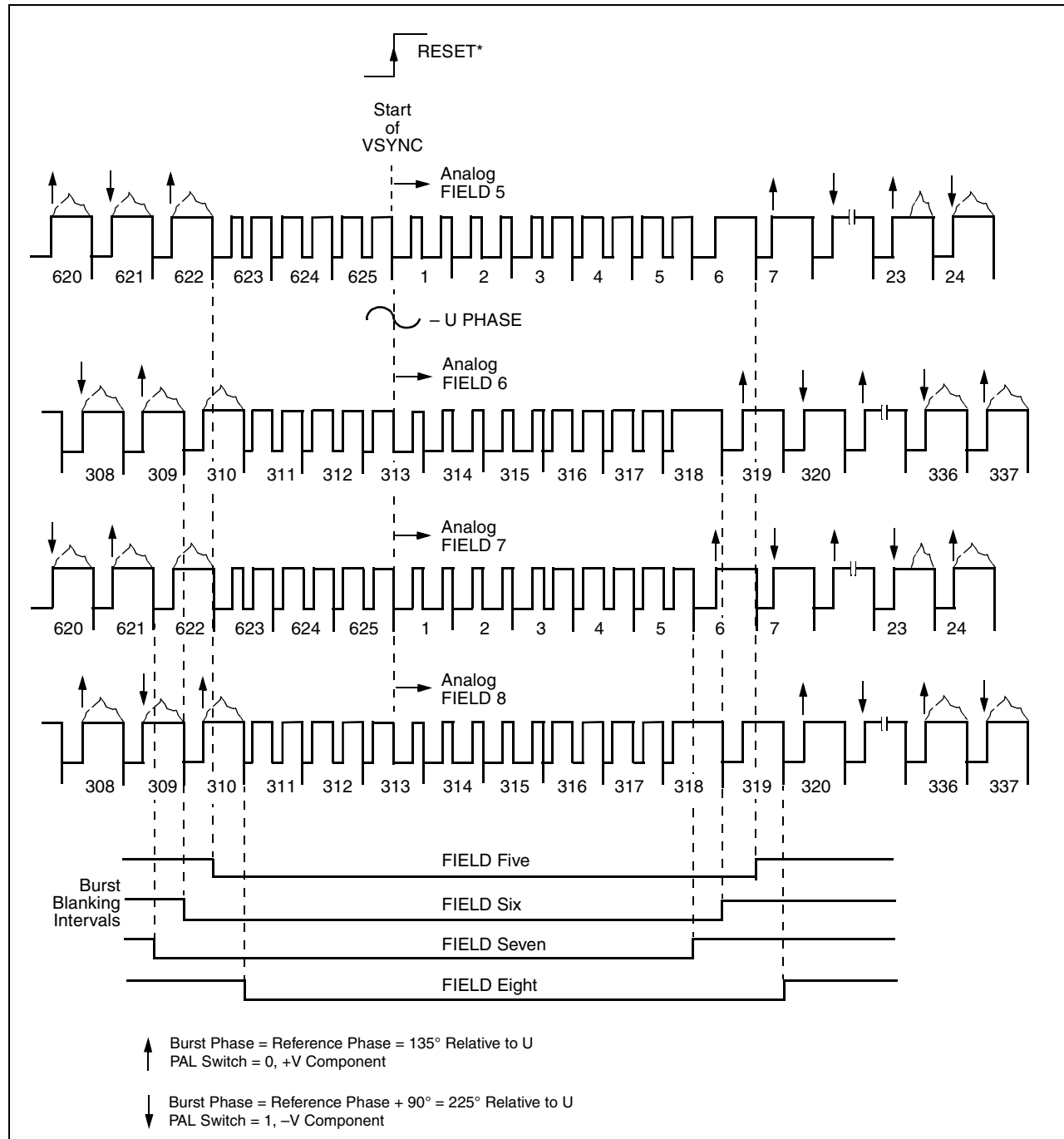

Figure 1-9. Interlaced 625-Line (PAL-N) Video Timing (Fields 1-4)

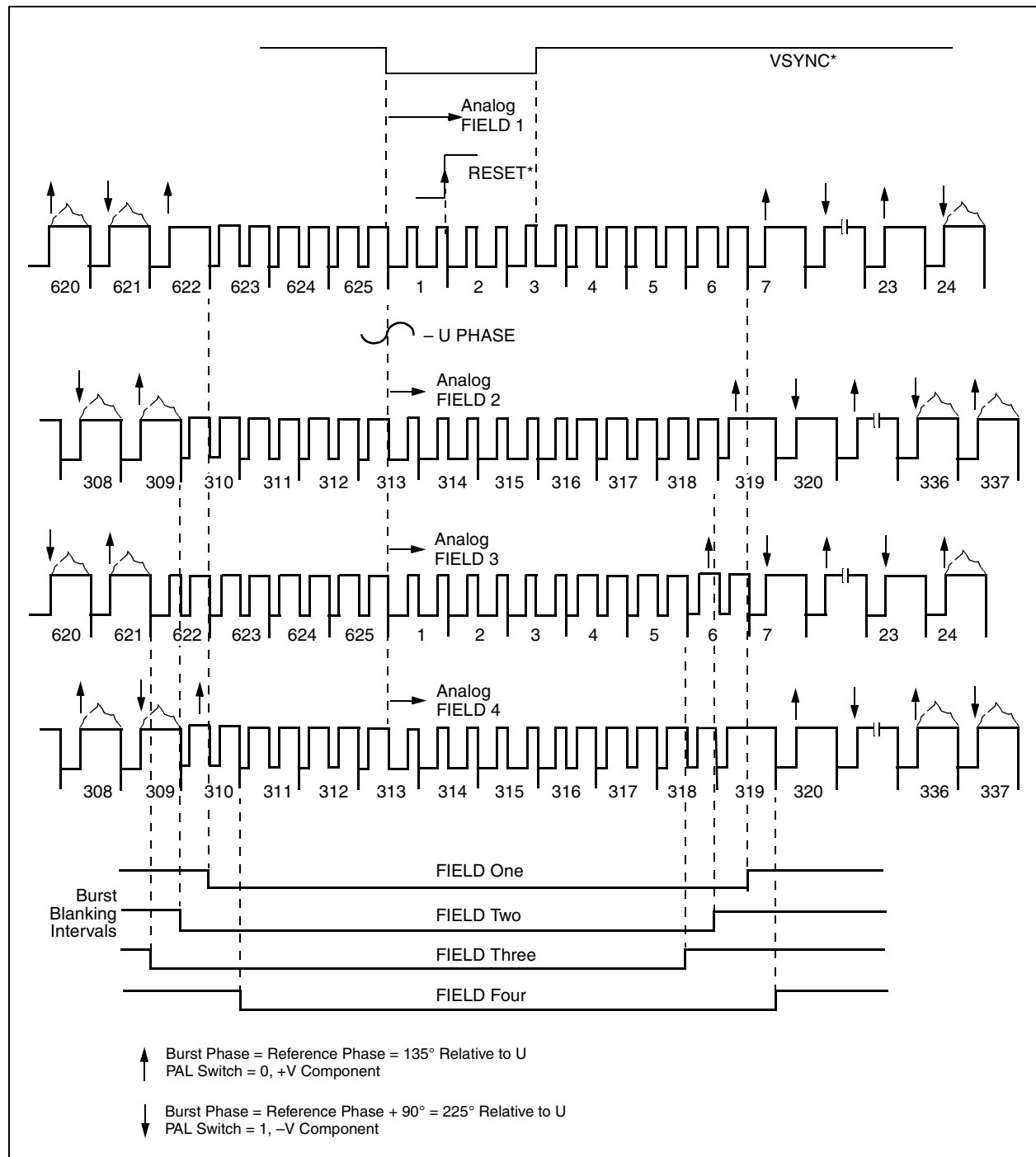

Figure 1-10. Interlaced 625-Line (PAL-N) Video Timing (Fields 5-8)

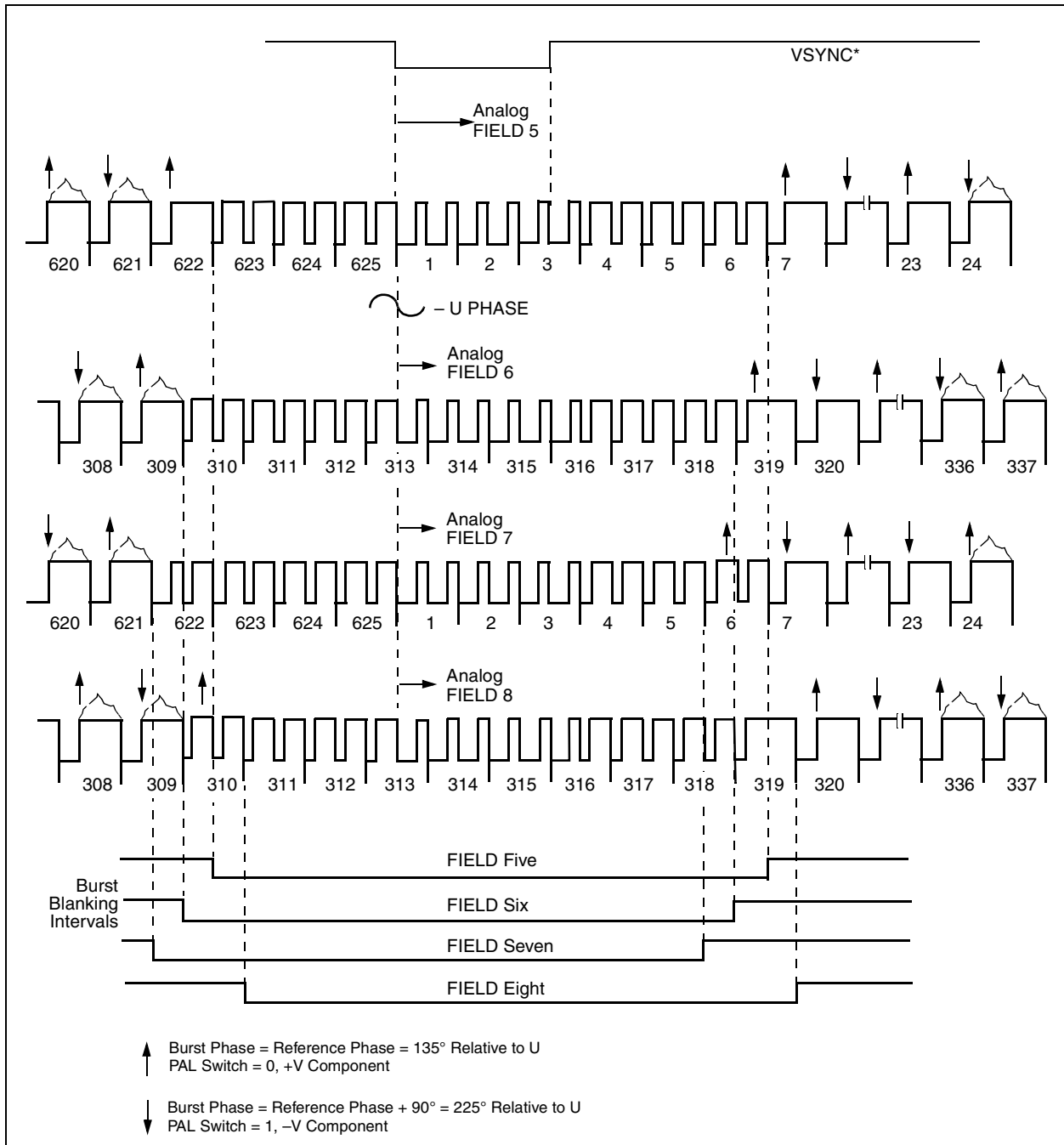

Figure 1-11. Noninterlaced 262-Line (NTSC) Video Timing

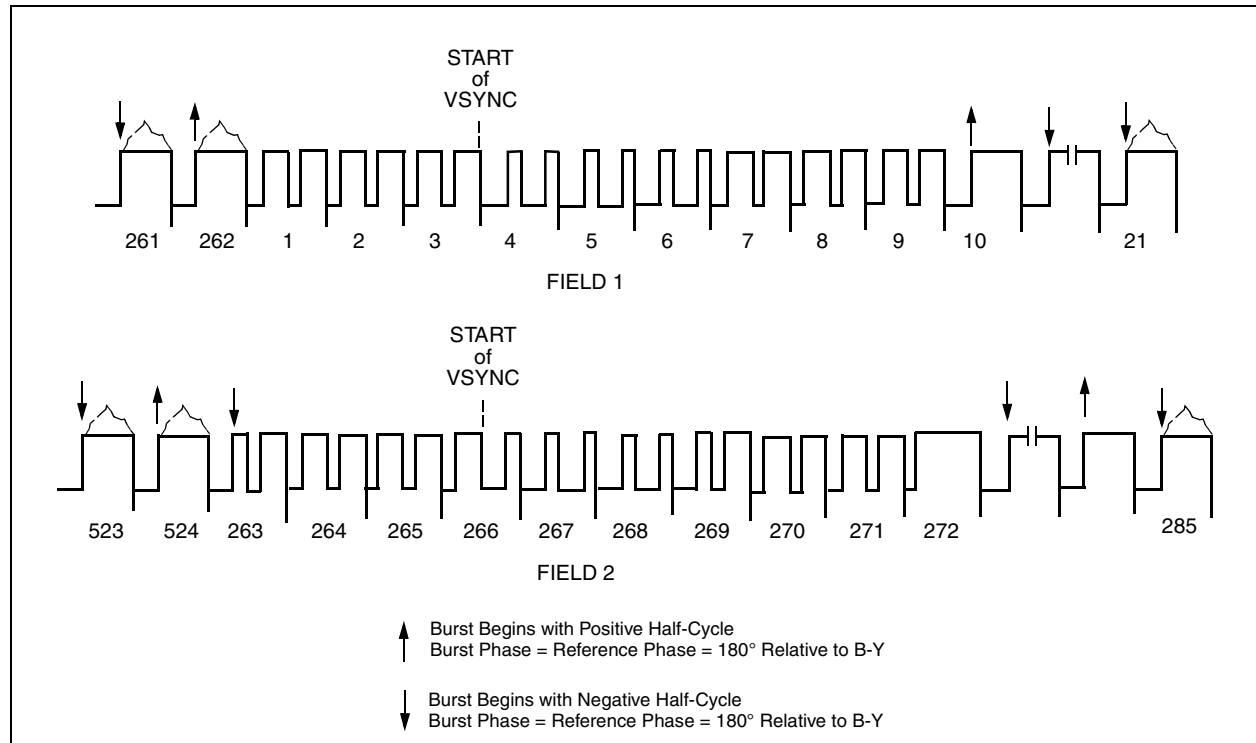

Figure 1-12. Noninterlaced 262-Line (PAL-M) Video Timing

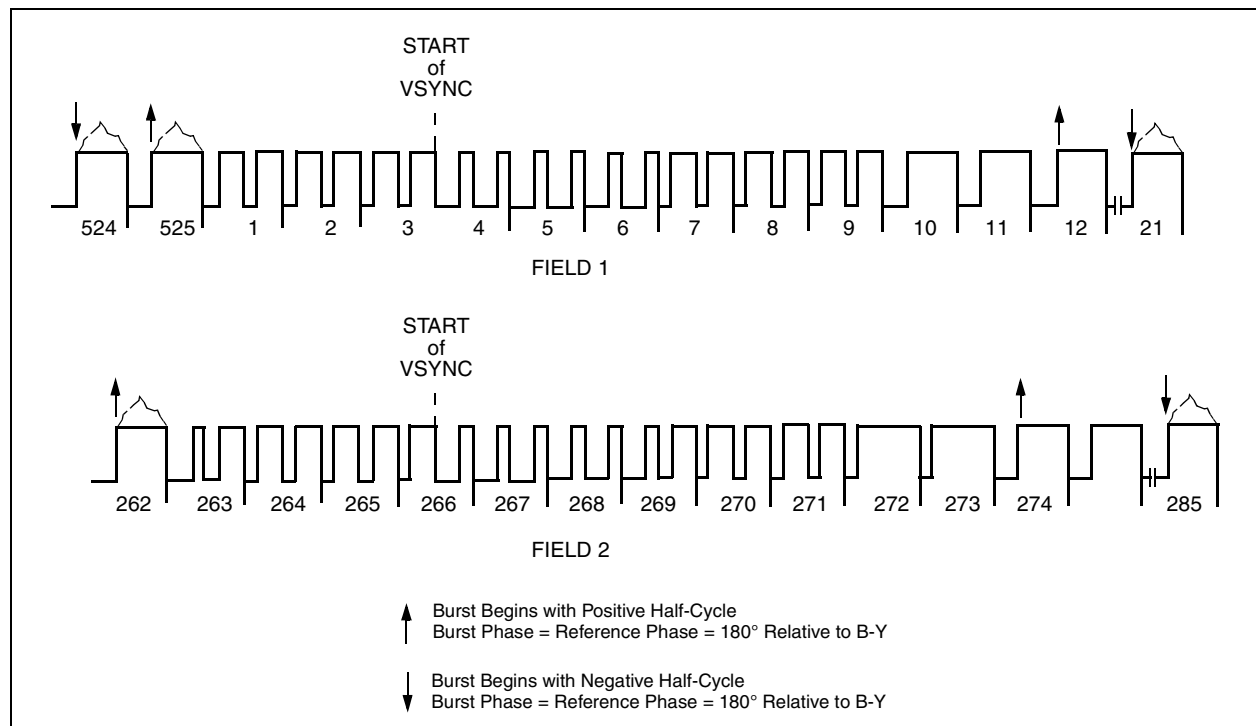
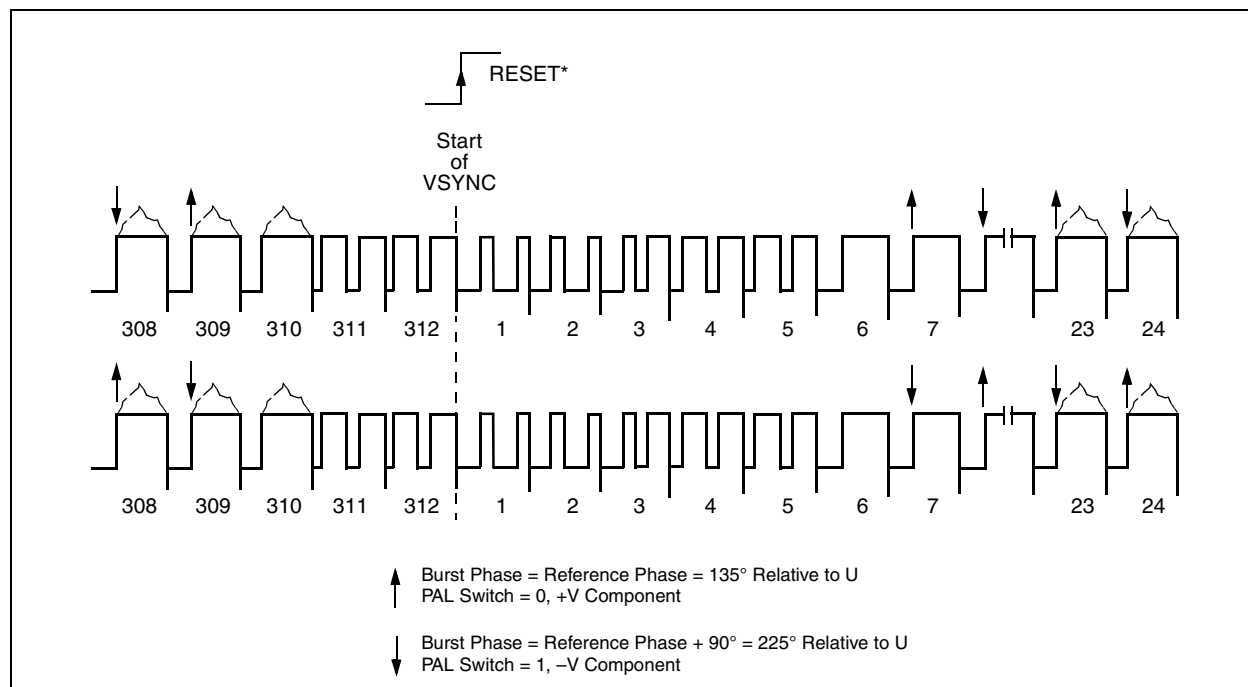

Figure 1-13. Noninterlaced 312-Line (PAL-B, D, G, H, I, N, Nc) Video Timing



1.3.23 Subcarrier Generation

The device uses a 32-bit-word to synthesize the subcarrier. The value of the subcarrier increment required to generate the desired subcarrier frequency is found with the following equation:

$$MSC[31:0] = (int) (2^{32} * F_{sc} / F_{clk} + 0.5)$$

or more directly, for NTSC:

$$MSC[31:0] = 2^{32} * [455 * / (2 * H_CLKO)]$$

and for PAL:

$$MSC[31:0] = 2^{32} * [(1135/4 + 1/625) / (H_CLKO)]$$

where F_{clk} is the encoder clock rate. This allows the generation of any desired subcarrier to enable the generation of any desired video standard. The 32-bit subcarrier increment $MSC[31:0]$ must be loaded by the serial interface before the subcarrier can be enabled. The device is reset to disable chroma until the last byte of the 32-bit increment is loaded, at which time the chroma will be enabled, unless the DCHROMA bit is set.

In order to prevent any residual errors from accumulating, the subcarrier DTO (Discrete Time Oscillator) is reset every four fields for NTSC formats and every eight fields for PAL formats.

1.3.24 Burst Generation

The subcarrier burst generation is a function of the video standard (e.g. NTSC or PAL), the subcarrier frequency increment (MSC[31:03]), and the burst horizontal begin and end register settings (HBURST_BEGIN[7:0] and HBURST_END[7:0]). The value of HBURST_BEGIN[7:0] and HBURST_END[7:0] is the desired pixel minus a value of 128. The burst will automatically be blanked during the horizontal sync to prevent invalid sync pulses from being generated. The burst blanking is automatically controlled by the selected video format. The burst rise and fall times are automatically generated by the device.

The burst amplitude can be programmed by BST_AMP[5:0]. Table 1-8 shows the ranges of burst values obtainable and the preferred values for various video formats.

1.3.25 Chrominance Disable

The chrominance subcarrier can be turned off by setting the DCHROMA bit to a logical 1. This kills burst as well, providing luminance-only signals on the CVBS output and a static blank level on the C/R output.

1.3.26 Digital Processing

Once the input data is converted into internal YUV format, the UV components are low-pass filtered with a filter response illustrated in Figure 1-14 (linearly scalable by clock frequency). The Y and filtered UV components are upsampled to CLK frequency by a digital filter whose response is illustrated in Figure 1-15.

Figure 1-14. Three-Stage Chroma Filter

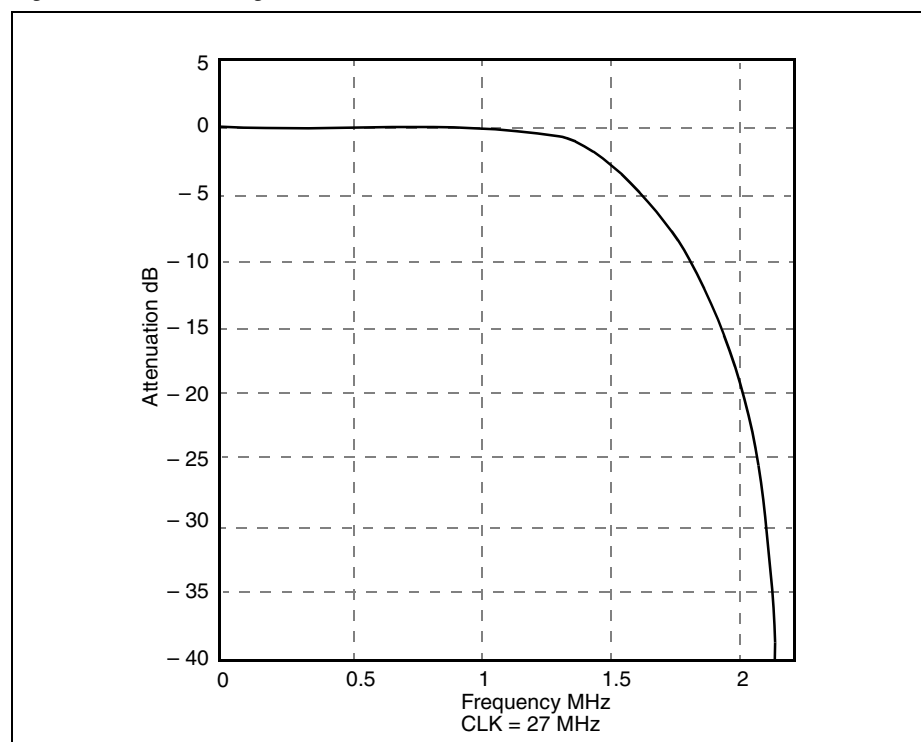
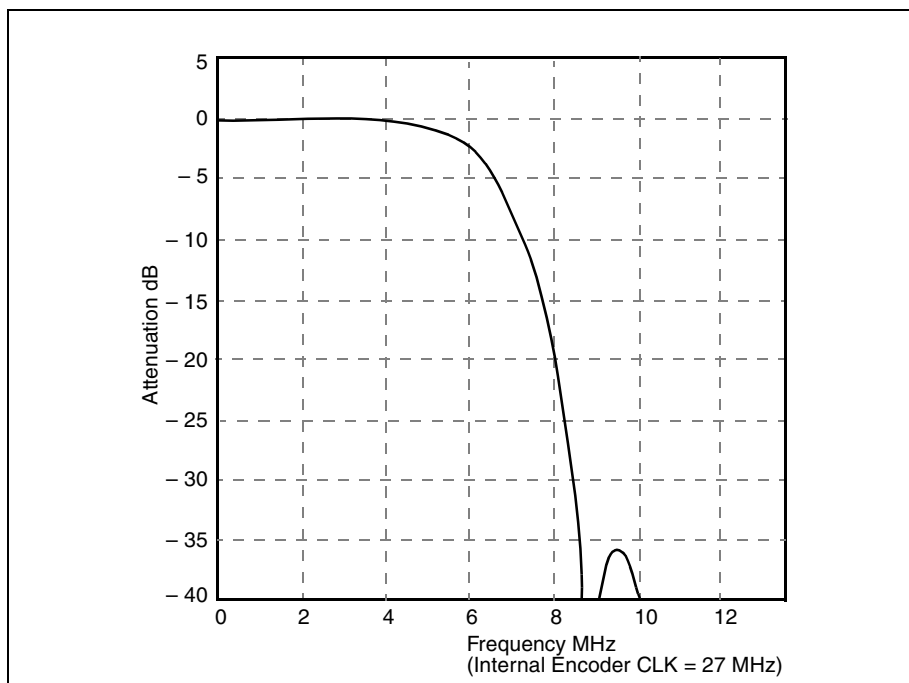

Figure 1-15. Luminance Upsampling Filter Response

1.3.27 Subcarrier Phasing

In order to maintain correct SC-H phasing, subcarrier phase is set to 0 on the leading edge of the analog vertical sync every four (NTSC) or eight (PAL) fields, unless the DIS_SCRESET bit is set to a logical 1. This is true for both interlaced and non-interlaced outputs. The subcarrier phase can be adjusted from the nominal 0 phase by the PHASE_OFF[7:0] register, where each LSB change corresponds to a 360/256 degree change in the phase.

Setting DIS_SCRESET to 1 may be useful in situations where the ratio of CLK/2 to HSYNC* edges in a color frame is noninteger, which could produce a significant phase impulse by resetting to 0.

1.3.28 Noninterlaced Operation

When the Bt868/869 is programmed for noninterlaced master mode, it always displays the odd field. FIELD will change state on the leading edge of the analog vertical sync. A 30 Hz offset should be subtracted from the color subcarrier frequency while in NTSC mode so that the color subcarrier phase will be inverted from field to field. Transition from interlaced to noninterlaced in master mode occurs during odd fields to prevent synchronization disturbance.

NOTE: Consumer VCRs can record noninterlaced video with minor noise artifacts, but special effects (e.g., scan > 2x) may not function properly.

1.3.29 Closed Captioning

The Bt868/869 encodes NTSC/PAL–M closed captioning on scan line 21, and NTSC/PAL–M extended data services on scan line 284. Four 8-bit registers (CCF1B1, CCF1B2, CCF2B1, and CCF2B2) provide the data while bits ECCF1 and ECCF2 enable display of the data. A logical 0 corresponds to the blanking level of 0 IRE, while a logical 1 corresponds to 50 IRE above the blanking level.

Closed captioning for PAL–B, D, G, H, I, N, Nc is similar to that for NTSC. Closed-caption (CC) encoding is performed for 625-line systems according to the system proposed by the National Captioning Institute; clock and data timing is identical to that of NTSC system, except that encoding is provided on lines 22 and 335, for closed captioning and extended data services respectively.

The Bt868/869 generates the clock run-in and appropriate timing automatically. Pixel inputs are ignored during CC encoding. See FCC Code of Federal Regulations (CFR) 47 Section 15.119 (10/91 edition or later) for programming information. EIA608 describes ancillary data applications for Field 2 Line 21 (line 284).

When CCF1B2 is written, CCSTAT_O is set; when CCF2B2 is written, CCSTAT_E is set. After the CC bytes for the odd field are encoded, CCSTAT_O is cleared; after the CC bytes for the even field are encoded, CCSTAT_E is cleared. If the ECCGATE bit is set, no further encoding will be performed until the appropriate registers are again written; a null will be transmitted on the appropriate CC line in that case. If the ECCGATE bit is not set, the user must rewrite the CC registers prior to reaching the CC line; otherwise the last bytes will be re-encoded. The CC data bytes are double-buffered to prevent loss of data during the encoding process.

1.3.30 Internal Color Bars

The Bt868/869 can be configured to generate 100% amplitude, 75% saturation (100/7.5/75/7.5 for NTSC/PAL–M with setup, 100/0/75/0 for PAL) color bars. Color bars can be enabled or disabled by setting the ECBAR bit to a logical 1. The device uses the H_BLANKO register value to determine the starting point of the color bars, and the H_ACTIVE register value to determine the width. Eight bars are displayed, with the colors and amplitudes being generated internally. The pixel inputs are ignored in color bar mode. The MY, MCR, and MCB registers must be programmed for RGB inputs prior to color bar operation.

1.3.31 Macrovision Encoding

The Bt869 device supports Version 7.xx of the Macrovision specification for copy protection for all NTSC and PAL modes. The Bt868 does not support the Macrovision feature.

1.3.32 Outputs

There are four modes for the analog outputs, selected by OUT_MODE[1:0]. The first mode (OUT_MODE=0) generates Composite video (CVBS), Luma (Y), Chroma (C), and Delayed Luma (Y_DLY). The second mode (OUT_MODE=1) generates Luma-Delayed Composite video (CVBS_DLY), Luma (Y), Chroma (C), and Delayed Luma (Y_DLY). The third mode (OUT_MODE=2) generates Component YUV and Delayed Luma (Y_DLY). The fourth mode (OUT_MODE=3) generates VGA-style RGB outputs. The LUMADLY[1:0] register bits control the amount of delay for the delayed luma, from 0 to 3 pixel clocks. For each mode, any of the four generated outputs can be muxed to any of three output DACs by the register bits OUT_MUXA[1:0], OUT_MUXB[1:0], and OUT_MUXC[1:0]. All digital-to-analog converters are designed to drive standard video levels into a combined RLOAD of 37.5 Ω (doubly-terminated 75 Ω). Unused outputs should be disabled by setting the corresponding DACDISX bit to minimize supply current, or connected directly to ground to minimize supply switching currents.

1.3.33 Output Connection Status

The device can determine whether or not the DAC output is connected to a monitor by verifying that the output is doubly-terminated. The MONSTATx bit for the corresponding DAC is set to a 1 if the device senses a doubly-terminated load on a reset condition or if the CHECK_STAT register bit is set. While CHECK_STAT is set, the output is forced to 2/3 of VREF when terminated and 4/3 of VREF if unterminated. The MONSTATx bit reflects the condition when the DAC output is less than or equal to VREF. The CHECK_STAT bit is automatically cleared after two clock cycles.

1.3.34 Output Filtering and SINX/X Compensation

The DAC output response is a typical $\sin x/x$ response. For the composite video output, this results in a slightly lower than desired burst and chroma amplitude value. This can be compensated for, to some extent, by choosing an output filter which boosts higher frequency response slightly. Another method which can be used effectively, and is used by default in the auto configuration modes, is to boost the burst and chroma gain as programmed by the BST_AMP and MCR/MCB register values by $x/\sin x$. The amount of $\sin x/x$ amplitude reduction is calculated by:

$$\sin x/x = \sin(\pi * Fsc/Fclk) / (\pi * Fsc/Fclk)$$

1.3.35 Power-Down Modes

The device can be placed in a low-power mode by the SLEEP pin. In this mode, the analog circuitry is shut down, disabling the output video, and the internal clock to the device is held constant, placing both the analog and digital current draw to a minimum. Register states are preserved, but other chip functionality (including the serial interface) is disabled. This mode achieves the greatest reduction in power.

In addition, the entire analog subsection can be powered-down with the DACOFF bit, allowing digital operations to continue while reducing the power in the analog circuitry. This will achieve a significant reduction in power while maintaining all digital functionality. Each individual DAC can also be powered down by its corresponding DACDISx bit. This is useful only if some of the DACs are being used, in order to minimize the power in the system.

1.3.36 Serial Interface

The device includes a 2-wire serial interface which is used for programming the registers in the device. The interface is designed to operate with either 3.3 V or 5 V input levels by changing the supply voltage for the input and output drivers with the VDD_SI pin.

2.0 Internal Registers

A register bit map is displayed in [Table 2-1](#), and a read-back bit map is displayed in [Table 2-2](#). Bit descriptions and detailed programming information follow the bit map. All registers are write-only and are set to 0 following a software reset. A software reset is always performed at power-up; after power-up, a reset can be triggered by writing the SRESET register bit.

Table 2-1. Register Bit Map (1 of 3)

8-Bit Address	D7	D6	D5	D4	D3	D2	D1	D0
6C	TIMING RESET	RESERVED						
6E	HSYNOFFSET[7:0]							
70	HSYNOFFSET[9:8]		HSYNWIDTH[5:0]					
72	VSYNOFFSET[7:0]							
74	DATDLY	DATSWP	VSYNOFFSET[10:8]			VSYNWIDTH[2:0]		
76	H_CLKO[7:0]							
78	H_ACTIVE[7:0]							
7A	HSYNC_WIDTH[7:0]							
7C	HBURST_BEGIN[7:0]							
7E	HBURST_END[7:0]							
80	H_BLANKO[7:0]							
82	V_BLANKO[7:0]							
84	V_ACTIVEO[7:0]							
86	V_ACTIVEO[8]	Reserved	H_ACTIVE[9:8]		H_CLKO[11:8]			
88	H_FRACT[7:0]							
8A	H_CLKI[7:0]							
8C	H_BLANKI[7:0]							
8E	Reserved	Reserved	Reserved	VBLANKDLY	H_BLANKI[8]	H_CLKI[10:8]		
90	V_LINESI[7:0]							
92	V_BLANKI[7:0]							
94	V_ACTIVEI[7:0]							
96	CLPF[1:0]		YLPF[1:0]		V_ACTIVEI[9:8]		V_LINESI[9:8]	

Table 2-1. Register Bit Map (2 of 3)

8-Bit Address	D7	D6	D5	D4	D3	D2	D1	D0
98	V_SCALE[7:0]							
9A	H_BLANKO[9:8]		V_SCALE[13:8]					
9C	PLL_FRACT[7:0]							
9E	PLL_FRACT[15:8]							
A0	EN_XCLK	BY_PLL	PLL_INT[5:0]					
A2	Reserved	ECLIP	PAL_MD	DIS_SCRESET	VSYNC_DUR	625LINE	SETUP	NI_OUT
A4	SYNC_AMP[7:0]							
A6	BST_AMP[7:0]							
A8	MCR[7:0]							
AA	MCB[7:0]							
AC	MY[7:0]							
AE	MSC[7:0]							
B0	MSC[15:8]							
B2	MSC[23:16]							
B4	MSC[31:24]							
B6	PHASE_OFF[7:0]							
B8					EN_PINCFG	CONFIG[2:0]		
BA	SRESET	CHECK_STAT	SLAVER	DACOFF	Reserved	DACDISC	DACDISB	DACDISA
BC	CCF2B1[7:0]							
BE	CCF2B2[7:0]							
C0	CCF1B1[7:0]							
C2	CCF1B2[7:0]							
C4	ESTATUS[1:0]		ECCF2	ECCF1	ECCGATE	ECBAR	DCHROMA	EN_OUT
C6	EN_BLANKO	EN_DOT	FIELDI	VSYNCl	HSYNCl	IN_MODE[2:0]		
C8	DIS_YFLPF	DIS_FFILT	F_SELc[2:0]			F_SELY[2:0]		
CA	DIS_GMUSHY	DIS_GMSHY	YCORING[2:0]			YATTENUATE[2:0]		
CC	DIS_GMUSHC	DIS_GMSHC	CCORING[2:0]			CATTENUATE[2:0]		
CE	Reserved		OUT_MUXC[1:0]		OUT_MUXB[1:0]		OUT_MUXA[1:0]	
D0	CCR_START[7:0]							
D2	CC_ADD[7:0]							
D4	MODE2X	DIV2	EN_ASYNC	CCR_START[8]	CC_ADD[11:8]			

Table 2-1. Register Bit Map (3 of 3)

8-Bit Address	D7	D6	D5	D4	D3	D2	D1	D0
D6	Reserved	Reserved	Reserved	Reserved	OUT_MODE[1:0]		LUMADLY[1:0]	
D8	Reserved							

2.1 Essential Registers

The power-up state is defined to be black burst CCIR601 NTSC video. To enable active video, the EN_OUT register bit must be set. This bit enables CLKO, HSYNC*, VSYNC*, BLANK*, and FIELD outputs. If this bit is not set, then these pins are set to a high impedance.

2.2 Writing Addresses

Following a start condition, writing 0x88 initiates access to subaddresses. Alternative address 0x8A must be written if the ALTADDR pin is high. If the data is written in subaddress order, only the beginning subaddress needs to be written; the internal address counter will automatically increment after each write to a register.

2.3 Reading Information

Following a start condition, writing 0x89 initiates the read-back sequence, during which 8 bits of information can be read from the SID pin, MSB first. Alternative address 0x8B is required if the ALTADDR pin is high. For the case of ESTATUS[1:0]=00 prior to the read sequence, the first three bits indicate the part type (Bt868 or Bt869). The lower five bits indicate the version number or the status bits. The instances where ESTATUS[1:0]=01 and ESTATUS[1:0]=10, the bits read back from the VGA Encoder will contain information as specified by [Table 2-2](#).

For software detection of a connected TV monitor on each DAC output, ESTATUS[1:0] must equal 01 and the MONSTAT x bits should be read accordingly after writing to CHECK_STAT.

Data details are defined in [Table 2-3](#); bit and register definitions are displayed in [Table 2-4](#).

Table 2-2. Read-Back Bit Map

ESTATUS[1:0]	7	6	5	4	3	2	1	0
00	ID[2:0]			VERSION[2:0]				
01	MONSTAT_A	MONSTAT_B	MONSTAT_C	CCSTAT_E	CCSTAT_O	FIELD[2:0]		
10				PLL_LOCK	FIFO_OVER	FIFO_UNDER	PAL	BUSY

Table 2-3. Data Details Defined

Bit Names	Data Definition
ID[2:0]	Indicates the part number: 000 is returned from the Bt868; 001 is returned from the Bt869.
VERSION[4:0]	Version number; for this revision, these bits are 00001.
MONSTAT_A	Monitor connection status for DACA output, 1 denotes monitor connected to DACA.
MONSTAT_B	Monitor connection status for DACB output, 1 denotes monitor connected to DACB.
MONSTAT_C	Monitor connection status for DACC output, 1 denotes monitor connected to DACC.
CCSTAT_E	High if closed-caption data has been written for the even field; it is low immediately after the clock run-in on line 21(NTSC) or 22(PAL).
CCSTAT_O	High if closed-caption data has been written for the odd field; it is low immediately after the clock run-in on line 284(NTSC) or 335(PAL).
FIELD[2:0]	Field number, where 000 indicates the first field, 111 indicates the 8th field.
PLL_LOCK	High when PLL is locked.
FIFO_OVER	Set to one if FIFO overflows. Reset on read.
FIFO_UNDER	Set to one if FIFO underflows. Reset on read.
PAL	Indicates status of PAL pin.
BUSY	Indicates that the device is in the process of initializing the registers and that the registers cannot be written. This bit remains high for 512 CLK-0 after an auto configuration cycle begins.

Table 2-4. Programming Detail (1 of 7)

Bit/Register Names	Bit/Register Definition
H_CLKO[11:0]	Number of output CLKs/line
H_ACTIVE[9:0]	Number of active input and output pixels
HSYNC_WIDTH[7:0]	Analog sync width in clocks
HBURST_BEGIN[7:0]	Beginning of burst 50% point in number of clock cycles from analog hsync falling edge
HBURST_END[7:0]	End of burst 50% point in number of clock cycles—128 from analog sync falling edge
H_BLANKO[9:0]	Number of output CLKs between leading edge of horizontal sync and active video
V_BLANKO[7:0]	Line number of first active line (number of blank lines + 1)
V_ACTIVEO[8:0]	Number of active output lines/field

Table 2-4. Programming Detail (2 of 7)

Bit/Register Names	Bit/Register Definition
H_FRACT[7:0]	Fractional number of input clocks per line
H_CLKI[10:0]	Number of clocks per line between successive HSYNC* edges
H_BLANKI[8:0]	Number of input pixels between HSYNC* leading edge and first active pixel
VBLANKDLY	If set, the effective vertical blanking value in the second field is V_BLANKI+1.
V_LINESI[9:0]	Number of vertical input lines
V_BLANKI[7:0]	Number of input lines between VSYNC* leading and first active line
V_ACTIVEI[9:0]	Number of active input lines
CLPF[1:0]	Chroma Horizontal Low Pass Filter 00 = Bypass 01 = Reserved 10 = Chroma Horizontal LPF2 11 = Chroma Horizontal LPF3
YLPF[1:0]	Luma Post-FlickerFilter/Scaler Horizontal Low Pass Filter 00 = Bypass 01 = Luma Horizontal LPF1 10 = Luma Horizontal LPF2 11 = Luma Horizontal LPF3
V_SCALE[13:0]	Vertical scaling coefficient
PLL_FRACT[15:0]	Fractional portion of PLL multiplier
PLL_INT[5:0]	Integer portion of PLL multiplier
EN_XCLK	0 = Encoder generates pixel clock 1 = Use CLKI pin as pixel clock source
BY_PLL	0 = Use PLL 1 = Bypass PLL (encoder clock is crystal frequency)
Reserved	Reserved for future software compatibility; should be set to zero for normal operation.
ECLIP	0 = Normal operation 1 = Enable clipping; DAC values less than 31 are made 31
PAL_MD	Video output switch bit. If PAL pin = 0, this controls analog output format 0 = Changes video output to NTSC mode 1 = Changes video output to PAL mode (even if PAL pin = 0)
DIS_SCRESET	0 = Normal operation. The subcarrier phase is reset to 0 at the beginning of each color field sequence 1 = Disables subcarrier reset event at beginning of field sequence
VSYNC_DUR	0 = Generates 2.5-line VSYNC analog output 1 = Generates 3-line VSYNC analog output
625LINE	0 = 525-line format 1 = 625-line format
SETUP	1 = Setup on. The 7.5-IRE setup is enabled for active video lines. 0 = Setup off. The 7.5-IRE setup is disabled for active video lines.
NI_OUT	0 = Interlaced analog video output 1 = Noninterlaced analog video output

Table 2-4. Programming Detail (3 of 7)

Bit/Register Names	Bit/Register Definition
SYNC_AMP[7:0]	Multiplication factor for sync amplitude
BST_AMP[7:0]	Burst amplitude multiplication factor
MCR[7:0]	Multiplication factor for CR (or R-Y) component prior to subcarrier modulation
MCB[7:0]	Multiplication factor for CB (or B-Y) component prior to subcarrier modulation
MY[7:0]	Multiplication factor for Y component
MSC[31:0]	Subcarrier increment
PHASE_OFF[7:0]	Subcarrier phase offset
EN_PINCFG	When set, this will enable the auto configuration to be controlled by P[23:21]. Whenever a change is detected on these pins, the mode is reconfigured.
CONFIG[2:0]	This field determines the configuration for the automatic configuration process 000 = NTSC 640x480 RGB input 001 = PAL 640x480 RGB input 010 = NTSC 800x600 RGB input 011 = PAL 800x600 RGB input 100 = NTSC 640x480 YCrCb input 101 = PAL 640x480 YCrCb input 110 = NTSC 800x600 YCrCb input 111 = PAL 800x600 YCrCb input
SRESET	Writing a 1 to this bit performs a software reset; all registers are reset to 0s unless the CONFIG[2:0] field is non-0; in that case, the automatic configuration process is begun and the BUSY status bit is set. This bit is automatically cleared.
CHECK_STAT	Writing a 1 to this bit checks the status of the monitor connections at the DAC output. This is also automatically performed on any reset condition, including a software reset. This bit is automatically cleared.
DACOFF	0 = Normal operation 1 = Disables DAC output current and internal voltage reference. This will limit power consumption to just the digital circuits.
DACDISC	0 = Normal operation 1 = Disables DAC output. Current is set to 0; output will go to 0 V.
DACDISB	0 = Normal operation 1 = Disables DACB output. Current is set to 0; output will go to 0 V.
DACDISA	0 = Normal operation 1 = Disables DACA output. Current is set to 0; output will go to 0 V.
CCF2B1[7:0]	This is the first byte of closed-caption information for the even field, line 284 for NTSC or line 335 for PAL. Data is encoded LSB first.
CCF2B2[7:0]	This is the second byte of closed-caption information for the even field, line 284 for NTSC or line 335 for PAL. Data is encoded LSB first.
CCF1B1[7:0]	This is the first byte of closed-caption information for the odd field, line 21 for NTSC or line 22 for PAL. Data is encoded LSB first.
CCF1B2[7:0]	This is the second byte of closed-caption information for the odd field, line 21 for NTSC or line 22 for PAL. Data is encoded LSB first.
ESTATUS[1:0]	Serial read-back status bit selection. (See Table 2-2.)

Table 2-4. Programming Detail (4 of 7)

Bit/Register Names	Bit/Register Definition
ECCF2	0 = Disables closed-caption encoding on field 2. 1 = Enables closed-caption encoding on field 2.
ECCF1	0 = Disables closed-caption encoding on field 1. 1 = Enables closed-caption encoding on field 1.
ECCGATE	0 = Normal closed-caption encoding. 1 = Enables closed-caption encoding constraints. After encoding, future encoding is disabled until a complete pair of new data bytes is received. This prevents encoding of redundant or incomplete data.
ECBAR	0 = Normal operation 1 = Enables color bars.
DCHROMA	0 = Normal operation 1 = Blank chroma
EN_OUT	0 = Three-states all outputs. 1 = Allows outputs to be enabled (depending upon EN_BLANKO register bit and SLAVE pin).
EN_BLANKO	Enables BLANK* pin as an output.
EN_DOT	Enables dot clock synchronization on BLANK* pin.
FIELDI	0 = Logical 1 on FIELD indicates an even field. 1 = Logical 1 on FIELD indicates an odd field.
VSYNCI	0 = Active low VSYNC* 1 = Active high VSYNC*
HSYNCI	0 = Active low HSYNC* 1 = Active high HSYNC*
IN_MODE[2:0]	Format of pixels at input of encoder: 000 = 24-bit RGB multiplexed 001 = 16-bit RGB multiplexed 010 = 15-bit RGB multiplexed 011 = 24-bit RGB non-multiplexed 100 = 24-bit YCrCb multiplexed 101 = 16-bit YCrCb multiplexed 110 = Reserved 111 = 24-bit YCrCb non-multiplexed
DIS_YFLPF	Luma Initial Horizontal Low Pass Filter 0 = Enable 1 = Disable
DIS_FFILT	0 = Enables FlickerFilter 1 = Disables FlickerFilter
F_SEL[2:0]	Chroma FlickerFilter: 000 = 5 Line 001 = 2 Line 010 = 3 Line 011 = 4 Line 100 = Alternate 5 Line 101 = Alternate 5 Line 110 = Alternate 5 Line 111 = Alternate 5 Line

Table 2-4. Programming Detail (5 of 7)

Bit/Register Names	Bit/Register Definition
F_SELY[2:0]	Luma FlickerFilter: 000 = 5 Line 001 = 2 Line 010 = 3 Line 011 = 4 Line 100 = Alternate 5 Line 101 = Alternate 5 Line 110 = Alternate 5 Line 111 = Alternate 5 Line
DIS_GMUSHY	0 = Enables Luma Anti-Psuedo Gamma Removal. 1 = Disables Luma Anti-Psuedo Gamma Removal.
DIS_GMSHY	0 = Enables Luma Psuedo Gamma Removal. 1 = Disables Luma Psuedo Gamma Removal.
YCORING[2:0]	Luma Coring: 000 = Bypass 001 = 1/128 of range 010 = 1/64 of range 011 = 1/32 of range 100 = 1/16 of range 101 = 1/8 of range 110 = 1/4 of range 111 = Reserved
YATTENUATE[2:0]	Luma Attenuation 000 = 1.0 gain (no attenuation) 001 = 15/16 gain 010 = 7/8 gain 011 = 3/4 gain 100 = 1/2 gain 101 = 1/4 gain 110 = 1/8 gain 111 = 0 gain (Force Luma to 0)
DIS_GMUSHC	0 = Enables Chroma Anti-Psuedo Gamma Removal. 1 = Disables Chroma Anti-Psuedo Gamma Removal.
DIS_GMSHC	0 = Enables Chroma Psuedo Gamma Removal. 1 = Disables Chroma Psuedo Gamma Removal.
CCORING[2:0]	Chroma Coring: 000 = Bypass 001 = 1/128 of range (+/- 1/256 of range) 010 = 1/64 of range (+/- 1/128 of range) 011 = 1/32 of range (+/- 1/64 of range) 100 = 1/16 of range (+/- 1/32 of range) 101 = 1/8 of range (+/- 1/16 of range) 110 = 1/4 of range (+/- 1/8 of range) 111 = Reserved

Table 2-4. Programming Detail (6 of 7)

Bit/Register Names	Bit/Register Definition
CATTENUATE[2:0]	Chroma Attenuation: 000 = 1.0 gain (No Attenuation) 001 = 15/16 gain 010 = 7/8 gain 011 = 3/4 gain 100 = 1/2 gain 101 = 1/4 gain 110 = 1/8 gain 111 = 0 gain (Force Chroma to 0)
OUT_MUXA[1:0]	00 = Output Video[0] on DACA 01 = Output Video[1] on DACA 10 = Output Video[2] on DACA 11 = Output Video[3] on DACA
OUT_MUXB[1:0]	00 = Output Video[0] on DACB 01 = Output Video[1] on DACB 10 = Output Video[2] on DACB 11 = Output Video[3] on DACB
OUT_MUXC[1:0]	00 = Output Video[0] on DACC 01 = Output Video[1] on DACC 10 = Output Video[2] on DACC 11 = Output Video[3] on DACC
CCR_START[8:0]	Closed-captioning clock run-in start in clock cycles from leading edge of HSYNC*
CC_ADD[11:0]	Closed-captioning DTO increment
DIV2	Divides input pixel rate by two (for CCIR601 interlaced timing input).
MODE2X	Divides selected input clock by two (allows for 2x rather than double-edge clock input).
EN_ASYNC	Set to 0 for normal operation.
OUT_MODE[1:0]	00 = Video[0-3] is CVBS/ Y/ C/ Y_DLY 01 = Video[0-3] is CVBS_DLY/ Y/ C/ Y_DLY 10 = Video[0-3] is V/ Y/ U/ Y_DLY 11 = Video[0-3] is R/ G/ B/ X (VGA mode)
LUMADLY[1:0]	This 2-bit value can be used to program the luminance delay in pixels for the CVBS_DLY and Y_DLY output modes. 00 = No delay 01 = 1 pixel 10 = 2 pixels 11 = 3 pixels
HSYNOFFSET[9:0]	A 2s-complement number. The values range from -512 pixels to +511 pixels. This register manipulates the falling edge position of the digital HSYNC output from Bt868. The default value is 0 and denotes the standard position of the HSYNC leading edge.

Table 2-4. Programming Detail (7 of 7)

Bit/Register Names	Bit/Register Definition
VSYNOFFSET[10:0]	A 2s-complement number. The values range from –HCLKI pixels to +HCLKI pixels. This register causes the falling edge position of the Bt868's digital VSYNC output to occur earlier (– value) or later (+) in time compared to the standard position for NTSC or PAL. The default value is 0 and denotes the standard position of the VSYNC leading edge.
HSYNWIDTH[5:0]	Controls the duration/width of the digital HSYNC output pulse. Value will be hexadecimal and its units are in terms of pixels. A value of 0 is a disallowed condition. The acceptable range is 2 pixels to 3F pixels (=63 decimal). The default value is 2.
VSYNWIDTH[2:0]	Controls the width of the VSYNC output pulse. Denotes the number of lines the VSYNC digital signal remains low on field transitions. Value will be hexadecimal value and its units are in terms of lines. A value of 0 is a disallowed condition. The acceptable range is 1 line to (2 ³ – 1) lines. The default value is 1.
DATDLY	Delays the falling edge pixel data by 1 full clock period when the falling edge data precedes the rising edge data. Ensures that the Bt868 moves the falling edge data after the rising edge data. The correct sequence of rising edge data/falling edge data/rising edge data will then be encoded by Buteo. The default value for this bit is 0 because most graphics controllers already transmit data in the expected rising edge data/falling edge data sequence.
DATSWP	Swaps the falling edge pixel data with the rising edge pixel data at the input of the pixel port. The default value for this bit is 0 which tells the VGA Encoder to expect an order of rising edge data/falling edge data coming from the graphics controller.
<p>NOTE(S): VSYNWIDTH, HSYNWIDTH, VSYNOFFSET, and HSYNOFFSET are active only when the Bt868/869 is in the master timing mode when the encoder outputs HSYNC and VSYNC pulses. In the slave timing mode, these registers are ignored. VSYNWIDTH and HSYNWIDTH should never be set to 0.</p>	

3.0 PC Board Considerations

For optimum performance of the Bt868/869, proper CMOS layout techniques should be studied in the *Bt451/457/458 Evaluation Module Operation and Measurements Application Note* (AN-16), before PC board layout is begun.

The layout should be optimized for lowest noise on the power and ground planes by providing good decoupling. The trace length between groups of VAA and GND pins should be as short as possible to minimize inductive ringing.

A well-designed power distribution network is critical to eliminating digital switching noise. The ground plane must provide a low-impedance return path for the digital circuits. A PC board with a minimum of four layers is recommended, with layers 1 (top) and 4 (bottom) for signals, and layers 2 and 3 for ground and power, respectively.

3.1 Component Placement

Components should be placed as close as possible to the associated pin in order for traces to be connected point to point. The optimum layout enables the Bt868/869 to be located close to the power supply connector and the video output connector. For an illustration, see [Figure 3-1](#).

3.2 Power and Ground Planes

For optimum performance, a common digital and analog ground plane and a common digital and analog power plane are recommended. The power plane should provide power to all Bt868/869 power pins, reference voltage (Vref) circuitry, and COMP decoupling.

The Bt868/869 power plane should be connected to the graphics system power plane (VCC) at a single point through a ferrite bead, as illustrated in Figures 3-1 and 3-2. This bead should be located within 3 inches of the Bt868/869. The bead provides resistance to switching currents, acting as a resistor at high frequencies. A low-resistance bead should be used, such as Ferroxcube 5659065-3B, Fair-Rite 2723021447, or TDK BF45-4001. See [Table 3-1](#) for a typical parts list for key passive components and [Figure 3-3](#) for a schematic diagram of the recommended layout.

Figure 3-1. Power Plane Illustration

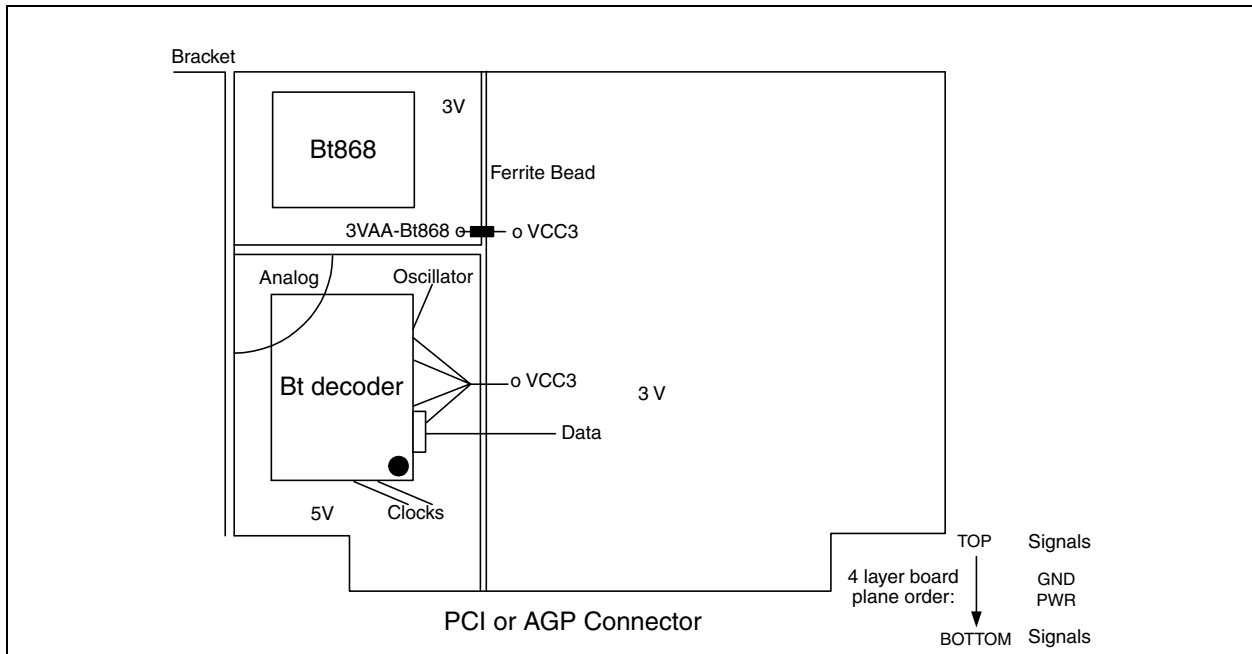
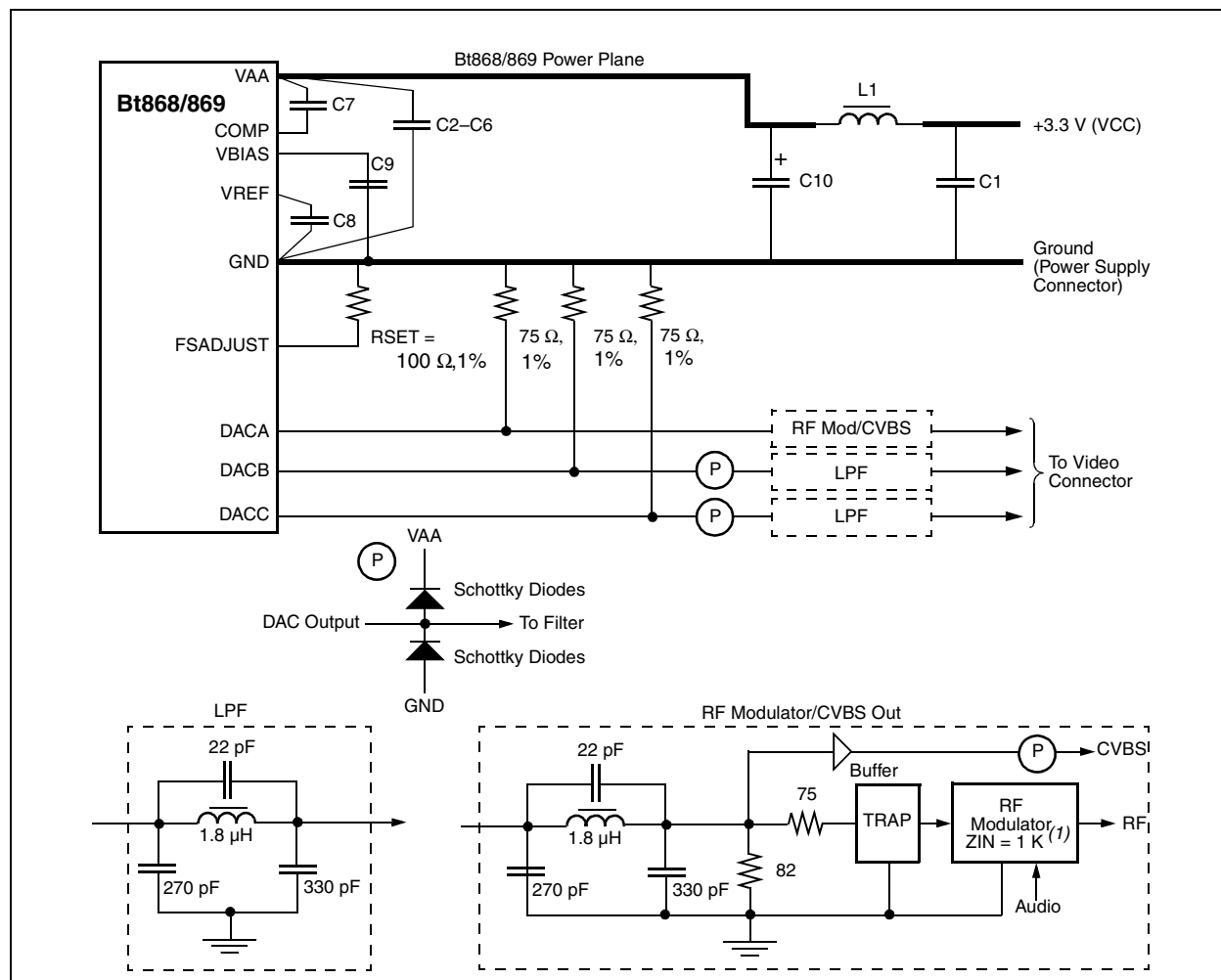

Figure 3-2. Connection Diagram for Output Filters and Other Key Passive Components



(1) Some modulators may require AC coupling capacitors (10 μF).

Table 3-1. Typical Parts List for Key Passive Components

Location	Description	Vendor Part Number
C1–C9	0.1 μF Ceramic Capacitor	Erie RPE112Z5U104M50V
C10	47 μF Capacitor	Mallory CSR13F476KM
L1	Ferrite Bead—Surface Mount	Fair-Rite 2743021447
RSET	1% Metal Film Resistor	Dale CMF-55C
TRAP	Ceramic Resonator	Murata TPSx.xMJ or MB2 (where x.x = sound carrier frequency in MHz)
	Schottky Diodes	BAT85 (BAT54F Dual) HP 5082-2305 (1N6263) Siemens BAT 64-04 (Dual)

NOTE(S): Vendor numbers are listed only as a guide. Substitution of devices with similar characteristics will not affect Bt868/869 performance.

Figure 3-3. Complete Bt868/Bt869 Recommended Layout

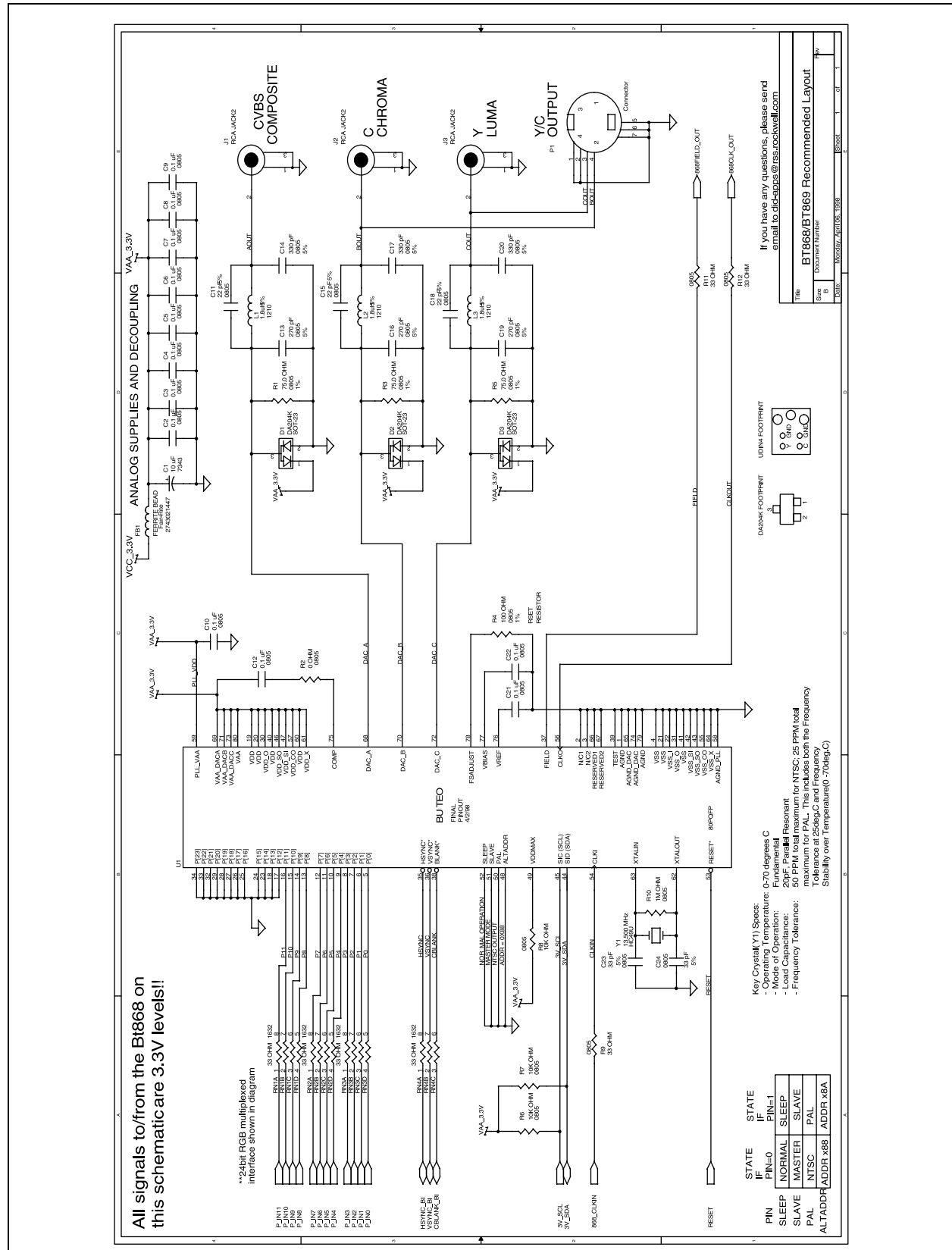

3.3 Decoupling

3.3.1 Device Decoupling

For optimum performance, all capacitors should be located as close as possible to the device, and the shortest possible leads (consistent with reliable operation) should be used to reduce the lead inductance. Chip capacitors are recommended for minimum lead inductance. Radial lead ceramic capacitors can be substituted for chip capacitors and are better than axial lead capacitors for self-resonance. Values are chosen to have self-resonance above the pixel clock.

3.3.2 Power Supply Decoupling

The best power supply performance is obtained with a 0.1 μF ceramic capacitor decoupling each group of VAA pins and each group of VDD pins to GND. The capacitors should be placed as close as possible to the device VAA/VDD pins and GND pins and connected with short, wide traces.

The 47 μF capacitor shown in [Figure 3-2](#) is for low-frequency power supply ripple; the 0.1 μF capacitors are for high-frequency power supply noise rejection.

When a linear regulator is used, the proper power-up sequence must be verified to prevent latchup. A linear regulator is recommended to filter the analog power supply if the power supply noise is greater than or equal to 200 mV. This is especially important when a switching power supply is used, and the switching frequency is close to the raster scan frequency. About 5% of the power supply hum and ripple noise less than 1 MHz will couple onto the analog outputs.

3.3.3 COMP Decoupling

The COMP pin must be decoupled to the closest VAA pin, typically with a 0.1 μF ceramic capacitor. Low-frequency supply noise will require a larger value. The COMP capacitor must be as close as possible to the COMP and VAA pins. A surface-mount ceramic chip capacitor is preferred for minimal lead inductance. Lead inductance degrades the noise rejection of the circuit. Short, wide traces will also reduce lead inductance.

3.3.4 VREF Decoupling

A 0.1 μF ceramic capacitor should be used to decouple this input to GND.

3.3.5 VBIAS Decoupling

A 0.1 μF ceramic capacitor should be used to decouple this output to GND.

3.4 Signal Interconnect

3.4.1 Digital Signal Interconnect

The digital inputs to the Bt868/869 should be isolated as much as possible from the analog outputs and other analog circuitry. Also, these input signals should not overlay the analog power plane or analog output signals.

Most of the noise on the analog outputs will be caused by excessive edge rates (less than 3 ns), overshoot, undershoot, and ringing on the digital inputs.

The digital edge rates should not be faster than necessary, as feedthrough noise is proportional to the digital edge rates. Lower-speed applications will benefit from using lower-speed logic (3–5 ns edge rates) to reduce data-related noise on the analog outputs.

Transmission lines will mismatch if the lines do not match the source and destination impedance. This will degrade signal fidelity if the line length reflection time is greater than one-fourth the signal edge time (refer to Application Notes AN-11 and AN-12). Line termination or line-length reduction is the solution. For example, logic edge rates of 2 ns require line lengths of less than 4 inches without use of termination. Ringing can be reduced by damping the line with a series resistor (30–300 Ω).

Radiation of digital signals can also be picked up by the analog circuitry. This is prevented by reducing the digital edge rates (rise/fall time), minimizing ringing with damping resistors, and minimizing coupling through PC board capacitance by routing the digital signals at a 90-degree angle to any analog signals.

The clock driver and all other digital devices must be adequately decoupled to prevent noise generated by the digital devices from coupling into the analog circuitry.

3.4.2 Analog Signal Interconnect

The Bt868/869 should be located as close as possible to the output connectors to minimize noise pickup and reflections caused by impedance mismatch.

The analog outputs are susceptible to crosstalk from digital lines; digital traces must not be routed under or adjacent to the analog output traces.

To maximize the high-frequency power supply rejection, the video output signals should overlay the ground plane.

For maximum performance, the analog video output impedance, cable impedance, and load impedance should be the same. The load resistor connection between the video outputs and GND should be as close as possible to the Bt868/869 to minimize reflections. Unused analog outputs should be connected to GND.

3.5 Applications Information

3.5.1 Electrostatic Discharge and Latchup Considerations

Correct electrostatic discharge (ESD)-sensitive handling procedures are required to prevent device damage. Device damage can produce symptoms of catastrophic failure or erratic device behavior with leaky inputs.

All logic inputs should be held low until power to the device has settled to the specified tolerance. DAC power decoupling networks with large time constants should be avoided; they could delay VAA and VDD power to the device. Ferrite beads must be used only for analog power VAA decoupling. Inductors cause a time-constant delay that induces latchup, and should not be substituted for a ferrite bead.

Latchup can be prevented by ensuring that all VAA and all GND pins are at the same potential and that the VAA and VDD supply voltage is applied before the signal pin voltages. The correct power-up sequence ensures that any signal pin voltage will never exceed the power supply voltage.

3.5.2 Clock and Subcarrier Stability

The color subcarrier is derived directly from the CLKO (derived from XTALIN/XTALOUT) CLKI when EN_XCLK=1 input, hence any jitter or frequency deviation of CLKO (XTALIN/XTALOUT) or CLKI when EN_XCLK=1 will be transferred directly to the color subcarrier. Jitter within the valid CLKO cycle interval will result in hue noise on the color subcarrier on the order of 0.9–1.6 degrees per nanosecond. Random hue noise can result in degradation in AM/PM noise ratio (typically around 40 dB for consumer media such as Videodiscs and VCRs). Periodic or coherent hue noise can result in differential phase error (which is limited to 10 degrees by FCC cable TV standards).

Any frequency deviation of CLKO from nominal will challenge the subcarrier tracking capability of the destination receiver. This may range from a few parts-per-million (ppm) for broadcast equipment to 100 ppm for industrial equipment, to a few hundred ppm for consumer equipment. Greater subcarrier tracking range generally results in poorer subcarrier decoding dynamic range, so that receivers that tolerate jitter and wide subcarrier frequency deviation will introduce more noise in the decoded image. Crystal-based clock sources with a maximum total deviation of 50 ppm (NTSC) or 25 ppm (PAL) across the temperature range of 0°C to 70°C produce the best results for consumer and industrial applications. In rare cases, temperature-compensated clock sources with tighter tolerances may be warranted for broadcast or more stringent PAL (e.g., type I) applications.

Some applications call for maintaining correct Subcarrier-Horizontal (SC-H) phasing for correct color framing. This requires subcarrier coherence within specified tolerances over a four-field interval for 525-line systems or 8 fields for 625-line systems. Any clock interruption (even during vertical blanking interval) which results in mis-registration of the CLKI input or nonstandard pixel counts per line, can result in SC-H excursions outside the NTSC limit of ± 40 degrees

(reference EIA RS170A) or the PAL limit of ± 20 degrees (reference EBU D23-1984).

In slave mode, any deviation exceeding the 50 ppm (NTSC) or 25 ppm (PAL) limits of the number CLKO cycles between HSYNC* falling edges when in slave mode may result in a switch to Master Mode.

3.5.3 Filtering Radio Frequency Modulator Connection

The Bt868/869's internal upsampling filter alleviates external filtering requirements by moving significant sampling alias components above 19 MHz and reducing the $\sin x/x$ aperture loss up to the filters passband cutoff of 5.75 MHz. While typical chrominance subcarrier decoders can handle the Bt868/869 output signals without analog filtering, the higher frequency alias products pose some EMI concerns and may create troublesome images when introduced to a radio frequency (RF) modulator. When the video is presented to an RF modulator, it should be free of energy in the region of the aural subcarrier (4.5 MHz for NTSC, 5.5–6.5 MHz for PAL). Hence some additional frequency traps may be necessary when the video signal contains fundamental or harmonic energy (as from unfiltered character generators) in that region. Where better frequency response flatness is required, some peaking in the analog filter is appropriate to compensate for residual digital filter losses with sufficient margin to tolerate 10% reactive components.

A three-pole elliptic filter (one inductor, three capacitors) with a 6.75 MHz passband can provide at least 45 dB attenuation (including $\sin x/x$ loss) of frequency components above 20 MHz and provide some flexibility for mild peaking or special traps. An inductor value with a self-resonant frequency above 80 MHz is chosen so that its intrinsic capacitance contributes less than 10% of the total effective circuit value. The inductor itself may induce 1% (0.1 dB) loss. Any additional ferrites introduced for EMI control should have less than 5 Ω impedance below 5 MHz to minimize additional losses. The capacitor to ground at the Bt868/869 output pin is compensating for the parasitic capacitance of the chip plus any protection diodes and lumped circuit traces (about 22 pF + 5 pF/diode). Some filter peaking can be accomplished by splitting the 75 Ω source impedance across the reactive PI filter network. However, this will also introduce some chrominance-luminance delay distortion in the range of 10–20 ns for a maximum of 0.5 dB boost at the subcarrier frequency.

The filter network feeding an RF modulator may include the aforementioned trap, which could take two forms depending on the depth of attenuation and type of resonator device employed.

The trap circuitry can interact with the lowpass filter, compromising frequency response flatness. A simple PNP buffer can preserve the benefits of an oversampling encoder when simultaneous Composite Video Baseband Signals (CVBS) are required for driving external cables. In addition, an active video buffer, serves to isolate the RF modulator signal amplitude from anomalies in the external termination. This buffer can be implemented with a transistor array or video amplify IC which provides a gain of two (before series termination), capable of driving 740 μ A into the 75 Ω destination, and is biased within its input/output compliance range. When simultaneous Y/C (s-video) outputs are not required, a second CVBS signal can be created (with a 600 mV sync to tip offset) by tying these pins together with a single termination resistor (typically 75 Ω) and driving the lowpass filter circuit.

The RF modulator typically has a high input impedance (about $1\text{k } \Omega \pm 30\%$) and loose tolerance. Consequently, the amplitude variation at the modulator input will be greater, especially when the trap is properly terminated at the modulator input for maximum effect. Some modulators, video or aural fidelity, degrade dramatically when overdriven, so the value of the effective termination (nominally $37.5 \text{ } \Omega$) may need to be adjusted downward to maintain sufficient linearity (or depth of modulation margin) in the RF signal.

A two-section trap (with associated inductor) may be warranted to achieve better than 20 dB attenuation when stereo, SAP, or AM aural carriers are generated, or when > 40 dB audio dynamic range is desired. Some impedance isolation (e.g., buffer) may be required before the trap to obtain the flattest frequency response. See [Figure 3-2](#).

3.6 Bt868/Bt869 Evaluation Board

See [Figure 3-4](#) for a schematic diagram of the Bt868 EVK evaluation card. This is a reference design intended to facilitate implementation of Conexant's VGA Encoder into a graphics card. The Bt868EVK may be obtained through your local Conexant Semiconductor sales office.

3.0 PC Board Considerations

Bt868/Bt869

3.6 Bt868/Bt869 Evaluation Board

Flicker-Free Video Encoder with Ultrascale™ Technology

Figure 3-4. Bt868/Bt869 Evaluation Board (1 of 6)

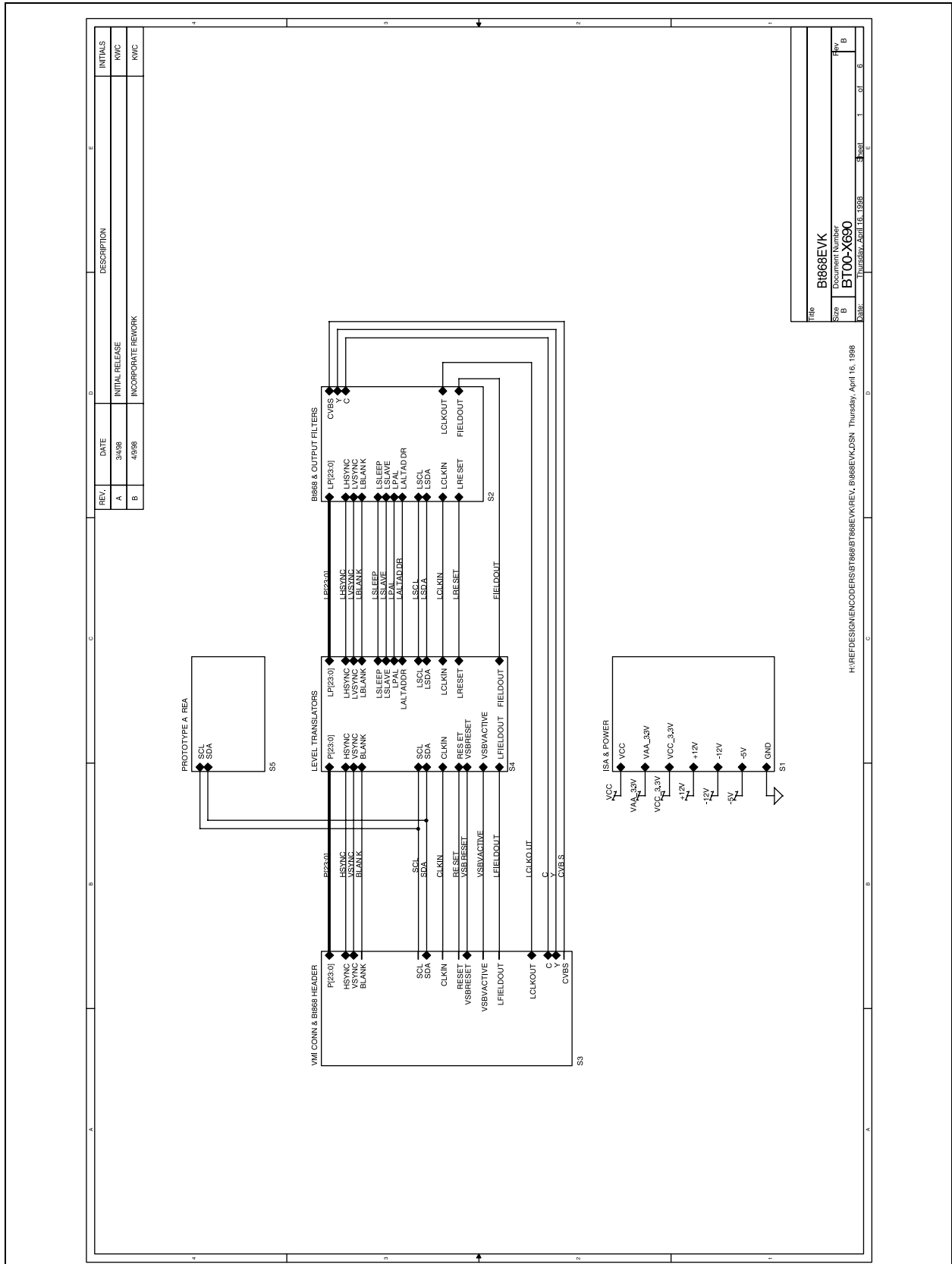

Figure 3-4. Bt868/Bt869 Evaluation Board (2 of 6)

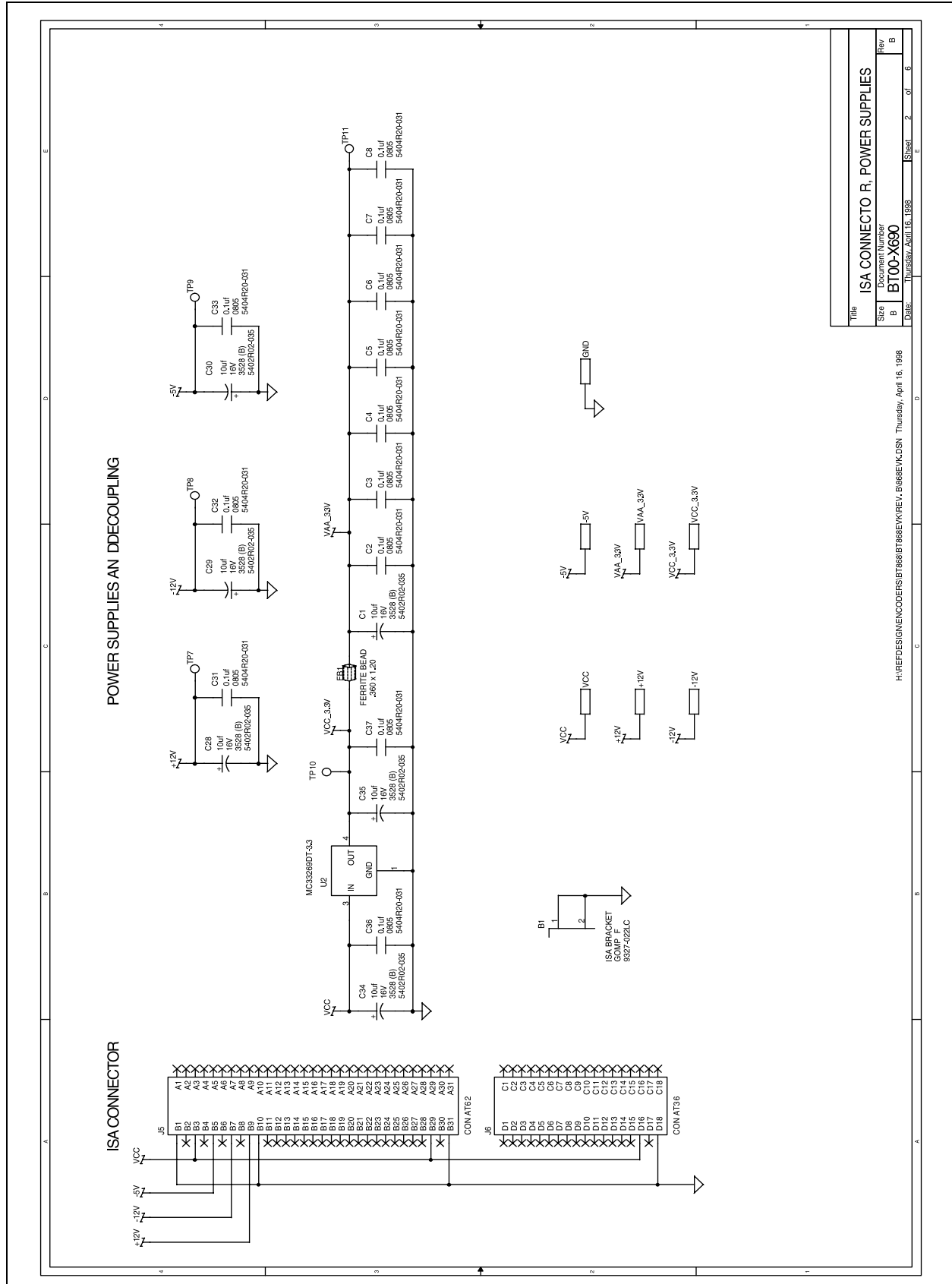

Figure 3-4. Bt868/Bt869 Evaluation Board (3 of 6)

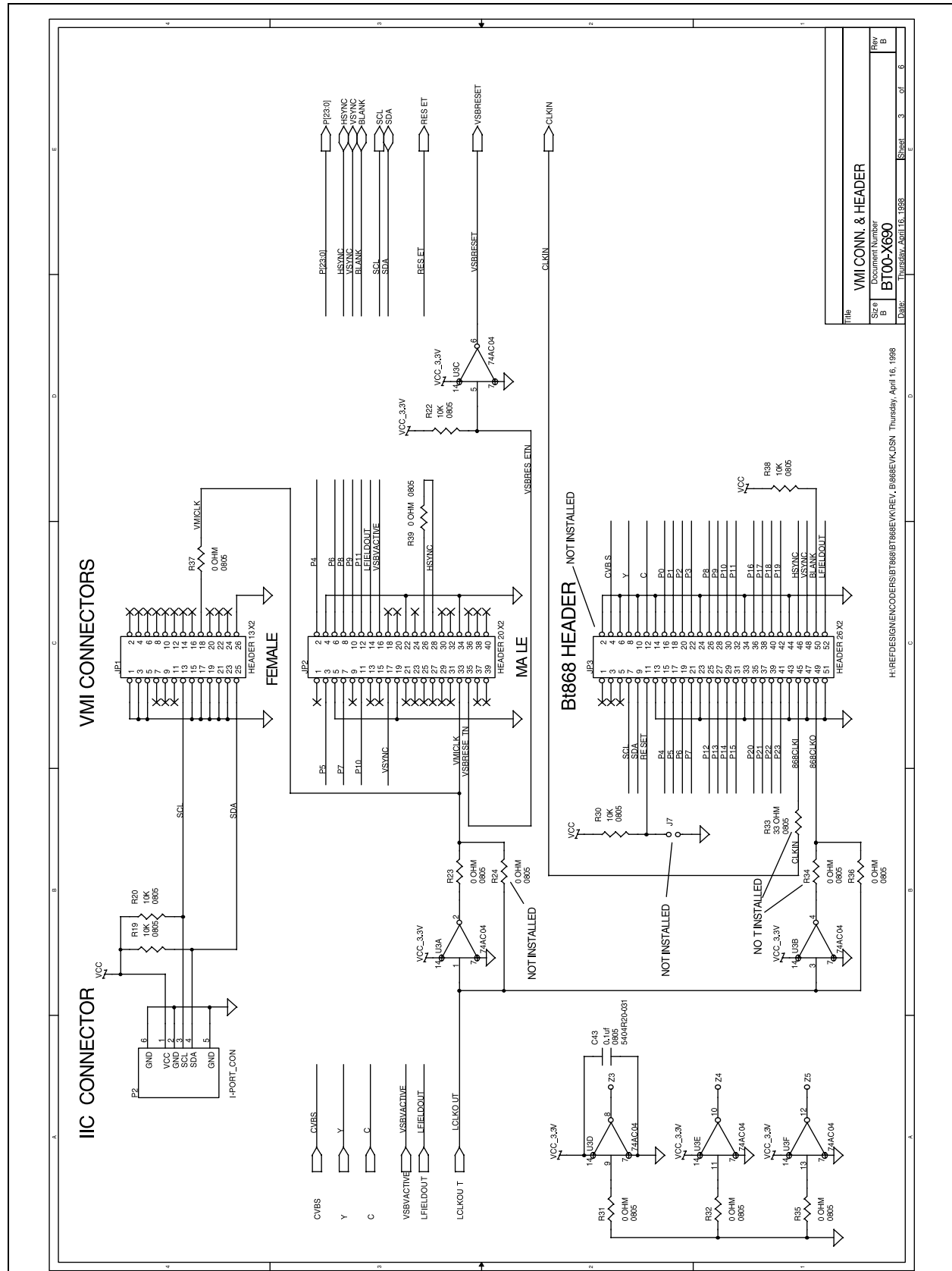

Figure 3-4. Bt868/Bt869 Evaluation Board (4 of 6)

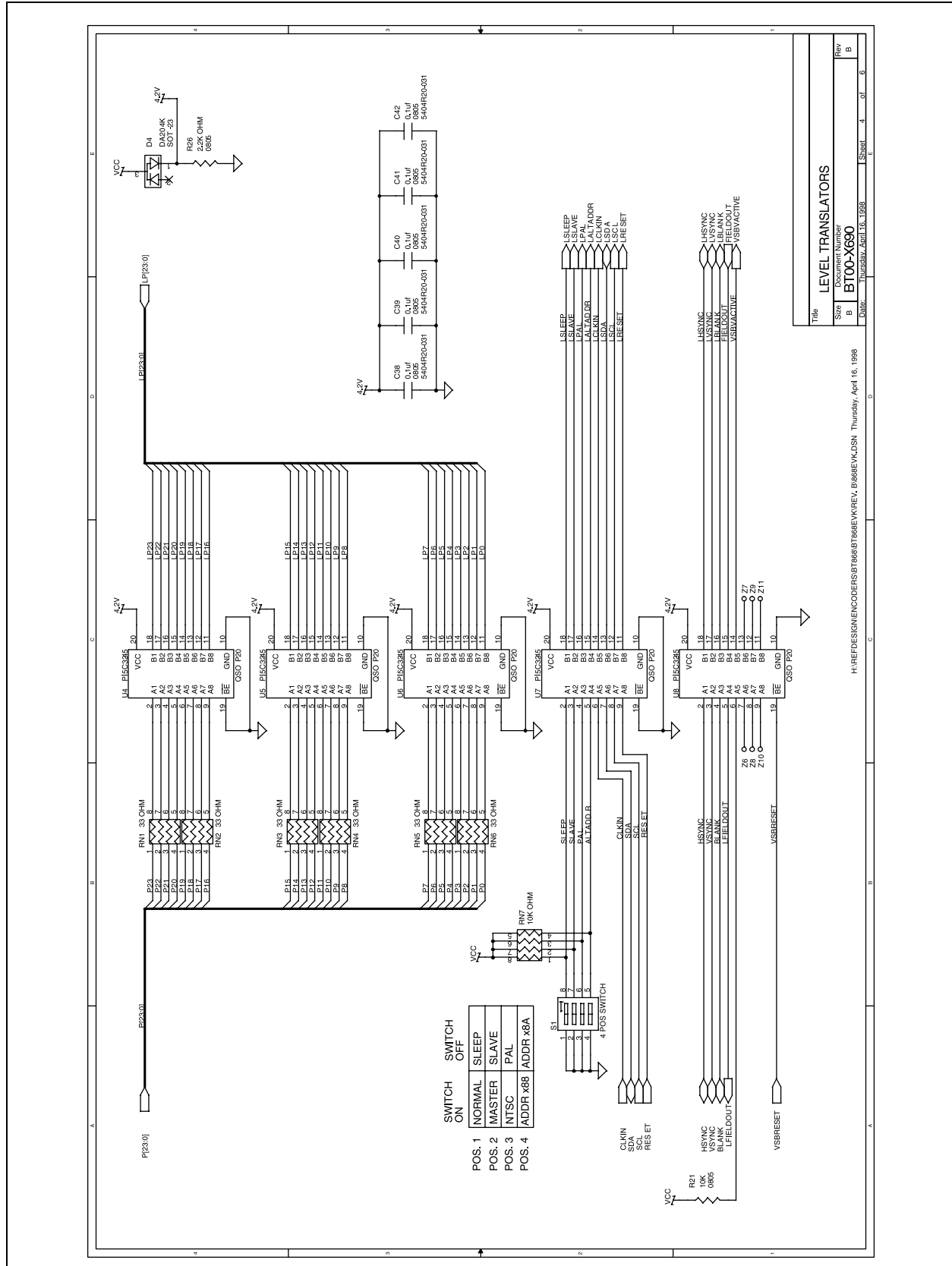

Figure 3-4. Bt868/Bt869 Evaluation Board (5 of 6)

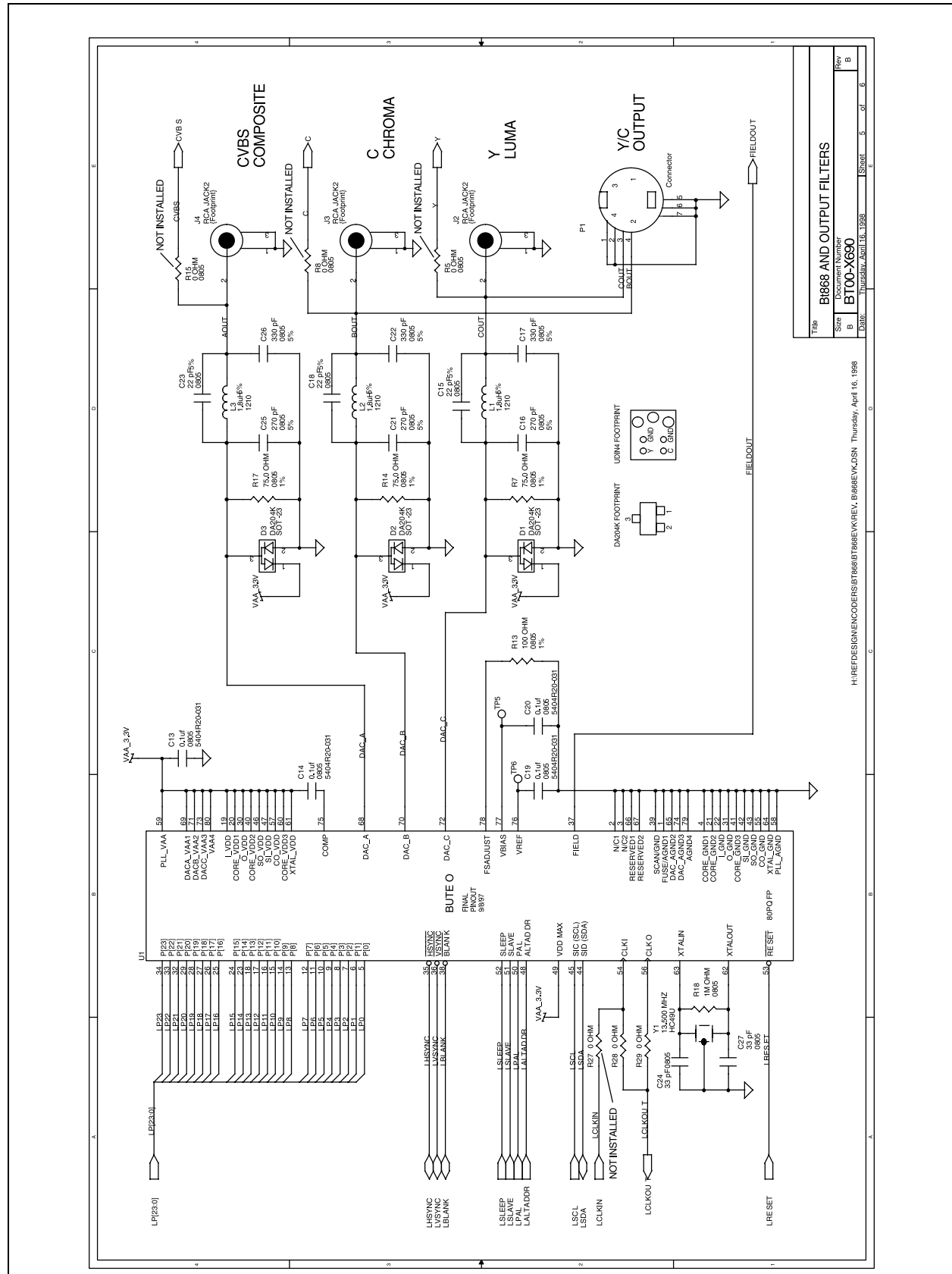
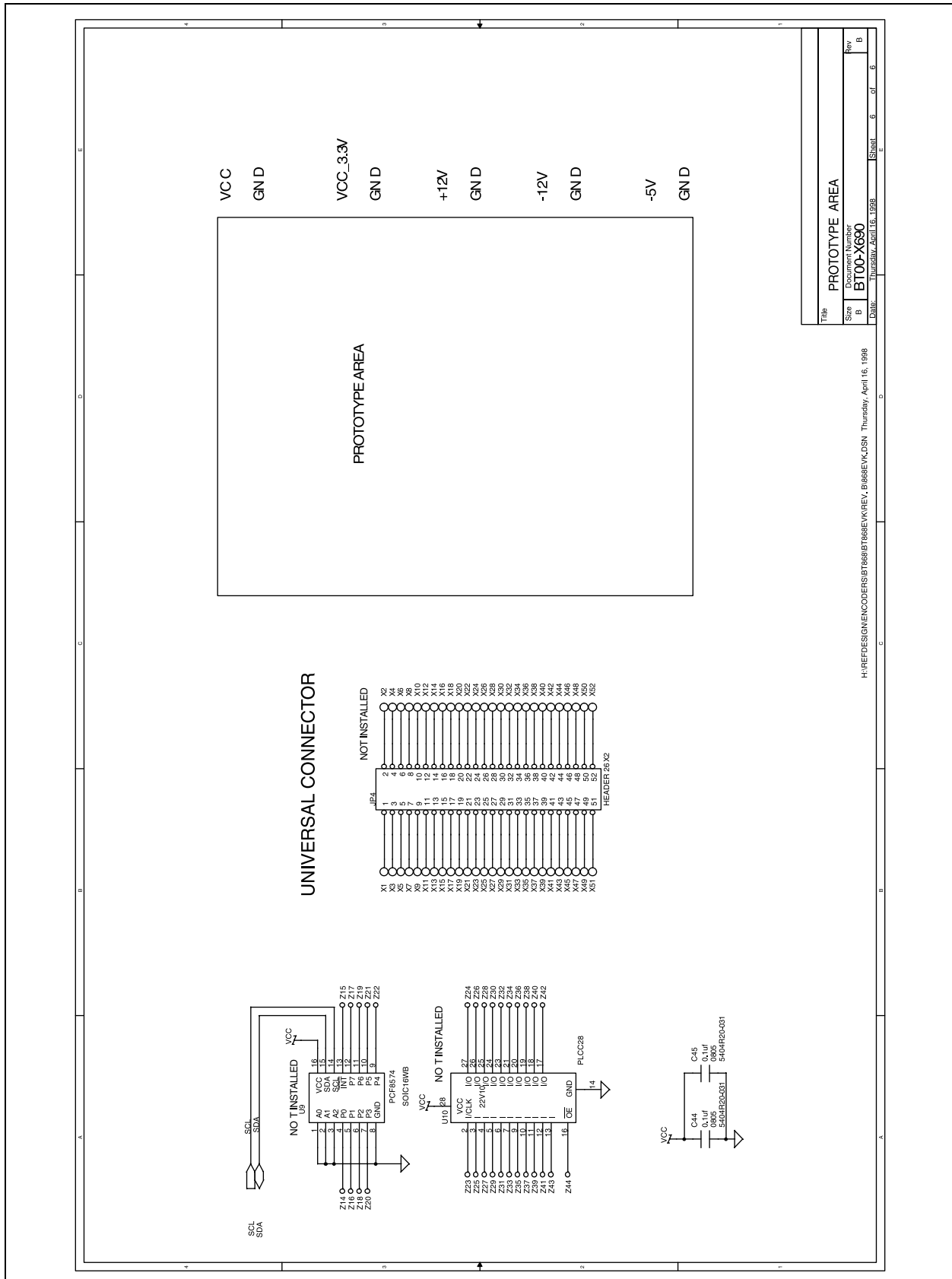

Figure 3-4. Bt868/Bt869 Evaluation Board (6 of 6)



3.7 Serial Interface

3.7.1 Data Transfer on the Serial Interface Bus

Figure 3-5 illustrates the relationship between SID (Serial Interface Data) and SIC (Serial Interface Clock) to be used when programming the internal registers via the Serial Interface bus. If the bus is not being used, both SID and SIC lines must be left high.

Every byte put onto the SID line should be 8 bits long (MSB first), followed by an acknowledge bit, which is generated by the receiving device. Each data transfer is initiated with a start condition and ended with a stop condition. The first byte after a start condition is always the slave address byte. If this is the device's own address, the device will generate an acknowledge by pulling the SID line low during the ninth clock pulse, then accept the data in subsequent bytes (auto-incrementing the subaddress) until another stop condition is detected.

The eighth bit of the address byte is the read/write bit (high = read from addressed device; low = write to the addressed device) so, for the Bt868/869, the subaddress is only considered valid if the R/W bit is low. Data bytes are always acknowledged during the ninth clock pulse by the addressed device. Note that during the acknowledge period, the transmitting device must leave the SID line high.

Premature termination of the data transfer is allowed by generating a stop condition at any time. When this happens, the Bt868/869 will remain in the state defined by the last complete data byte transmitted and any master acknowledge subsequent to reading the chip ID (subaddress 0x89) is ignored.

Figure 3-5. SID/SIC Diagram

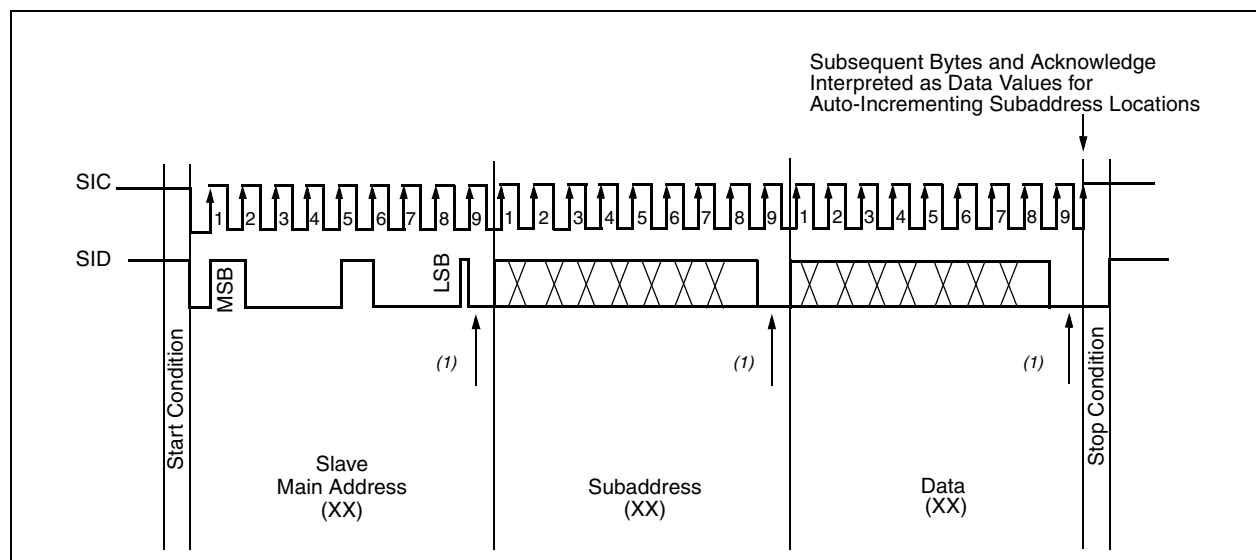

(1) Acknowledge generated by Bt868/869.

4.0 Parametric Information

4.1 DC Electrical Parameters

DC electrical parameters are defined in [Tables 4-1](#) through [4-3](#). AC electrical parameters are defined in [Table 4-4](#). Timing diagrams are in [Figures 4-1](#) through [4-3](#).

Table 4-1. Recommended Operating Conditions

Parameter	Symbol	Min	Typ	Max	Units
Power Supply	VAA, VDD	3.00	3.30	3.60	V
Serial Input Supply	VDD_SI	3.00		5.25	V
Ambient Operating Temperature	TA	0		70	°C
DAC Output Load	RL		37.5		W
Nominal RSET	RSET		100.0		W

Table 4-2. Absolute Maximum Rating (1 of 2)

Parameter	Symbol	Min	Typ	Max	Units
VAA, VDD (measured to GND)				7.0	V
VDD_SI (measured to GND)				7.0	V

Table 4-2. Absolute Maximum Rating (2 of 2)

Parameter	Symbol	Min	Typ	Max	Units
Voltage on Any Signal Pin (1)		GND – 0.5		VDD_SI+ 0.5	V
Analog Output Short Circuit Duration to Any Power Supply or Common	ISC		Indefinite		
Storage Temperature	TS	– 65		+150	°C
Junction Temperature	TJ			+125	°C
Vapor Phase Soldering (1 Minute)	TVSOL			220	°C
<p>(1) This device employs high-impedance CMOS devices on all signal pins. It should be handled as an ESD-sensitive device. Voltage on any signal pin that exceeds the power supply or ground voltage by more than 0.5 V can cause destructive latchup.</p> <p> Stresses above those listed under “Absolute Maximum Ratings” can cause permanent damage to the device. This is a stress rating only, and functional operation of the device at these or any other conditions above those listed in the operational sections of this specification is not implied. Exposure to absolute maximum rating conditions for extended periods can affect device reliability.</p>					

Table 4-3. DC Characteristics (1 of 2)

Parameter	Symbol	Min	Typ	Max	Units
Video D/A Resolution		10	10	10	Bits
Output Current-DAC Code 1023 (Iout Full Scale)			34.13		mA
Output Voltage-DAC Code 1023			1.28		V
Video Level Error (Nominal Resistors)				5	%
Output Capacitance (of DAC output)			22		pF
Digital Inputs (Except those specified below)					
Input High Voltage	VIH	2.0		VDD_I + 0.5	V
Input Low Voltage	VIL	GND – 0.5		0.8	V
Input High Current (Vin = 2.4 V)	IiH			1	μA
Input Low Current (Vin = 0.4 V)	IiL			– 1	μA
Input Capacitance (f = 1 MHz, Vin = 2.4 V)	CIN		7		pF
SID, SDO					
Input High Voltage	VIH	0.7 * VDD_SI		VDD_SI + 0.5	V
Input Low Voltage	VIL	GND – 0.5		0.3 * VDD_SI	V
CLKI Input					
Input High Voltage	VIH	2.4		VDD_I + 0.5	V
Input Low Voltage	VIL	GND – 0.5		0.8	V

Table 4-3. DC Characteristics (2 of 2)

Parameter	Symbol	Min	Typ	Max	Units
Digital Outputs					
Output High Voltage (IOH = -400 μ A)	VOH	2.4		VDD	V
Output Low Voltage (IOL = 3.2 mA)	VOL	GND		0.4	V
Three-State Current	IOZ			50	μ A
Output Capacitance	CDOUT		10		pF
<p>NOTE(S): Recommended Operating Conditions, NTSC CCIR 601 operation, and internal clock frequency = 27 MHz. As the above parameters are guaranteed over the full temperature range (0°C to 70°C), temperature coefficients are not specified or required. Typical values are based on nominal temperature, i.e., room temperature, and nominal voltage, i.e., 3.3 V.</p>					

4.2 AC Electrical Parameters

Table 4-4. AC Characteristics (1 of 2)

Parameter	EIA/TIA 250C Ref	CCIR 567	Symbol	Min	Typ	Max	Units
Hue Accurac(1, 2)							± ×
Color Saturation Accuracy(1, 2)							± %
Chroma AM/PM Noise(3)	1 MHz Red Field						dB rms
Differential Gain(2)	6.2.2.1	C3.4.1.3					% p-p
Differential Phase(2)	6.2.2.2	C3.4.1.4					× p-p
SNR (Unweighted 100 IRE Y Ramp Tilt Correct)(2)							
RMS	6.3.1						dB rms
Peak Periodic	6.3.2						dB p-p
100 IRE Multiburst(3)	6.1.1						± IRE
Gain/frequency		C3.5.4.1					
Chroma/Luma Gain Ineq(3)	6.1.2.2	C3.5.3.1					± IRE
Chroma/Luma Delay Ineq(3)	6.1.2	C3.5.3.2					ns
Short Time Distortion 100 IRE/PIXEL(3)	6.1.6						%
Luminance Nonlinearity(2)	6.2.1						%
Chroma/Luma Intermod(2)	6.2.3						± IRE
Chroma Nonlinear Gain(2)	6.2.4.1						± IRE
Chroma Nonlinear Phase(2)	6.2.4.2						± ×
Pixel/Control Setup Time(2)			1	3		12	ns
Pixel/Control Hold Time(2)			2	.35			ns
Control Output Delay Time(4)			3			15	ns
Control Output Hold Time(4)			4	2			ns
CLKI/O Frequency						40.5	MHz
CLKI/O Pulse Width Low Duty Cycle				40	50	60	%
CLKI/O Pulse Width High Duty Cycle				40	50	60	%

Table 4-4. AC Characteristics (2 of 2)

Parameter	EIA/TIA 250C Ref	CCIR 567	Symbol	Min	Typ	Max	Units
CLKO to CLKI Delay			7			0.8	CLKO cycles
SLAVE to HSYNC*/VSYNC* Three-state			5	2			CLKI cycles
SLAVE to HSYNC*/VSYNC* Active			6			2	CLKI cycles
VAA Supply Current					132		mA
VAA Power-Down Current					1		mA
VDD Supply Current					118		mA
VDD Power-Down Current					1		mA
Total Supply Current					250		mA
<p>(1) 5/7.5/75/7.5 Color bars normalized to burst. (2) Guaranteed by characterization. (3) Without post filter. Guaranteed by design. (4) Control pins are defined as: P[11:0], BLANK*, HSYNC*, VSYNC*, FIELD, CLKDIR, RESET*, PAL, and SLAVE. 5. "Recommended Operating Conditions," NTSC CCIR 601 operation, and CLK frequency = 27 MHz. Analog output load \leq 75 pF. HSYNC*, VSYNC*, BLANK*, and FIELD output load \leq 75 pF. As the above parameters are guaranteed over the full temperature range, temperature coefficients are not specified or required. Typical values are based on nominal temperature, i.e., room temperature, and nominal voltage, i.e., 3.3 V. Video input and output timing is shown in Figure 4-1.</p>							

Figure 4-1. Interface Timing

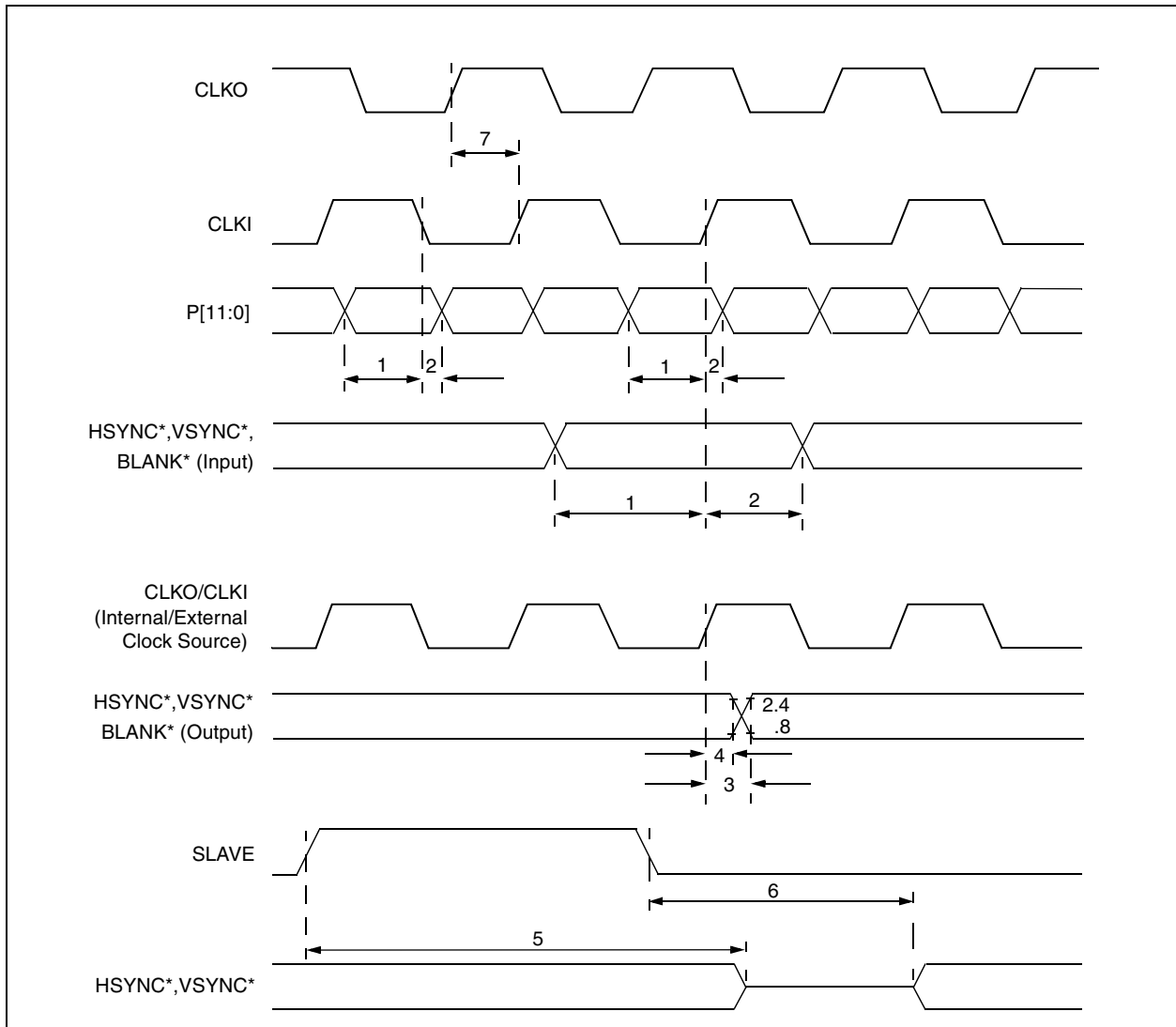

Figure 4-2. Master Mode with Flicker Filter Interface Timing

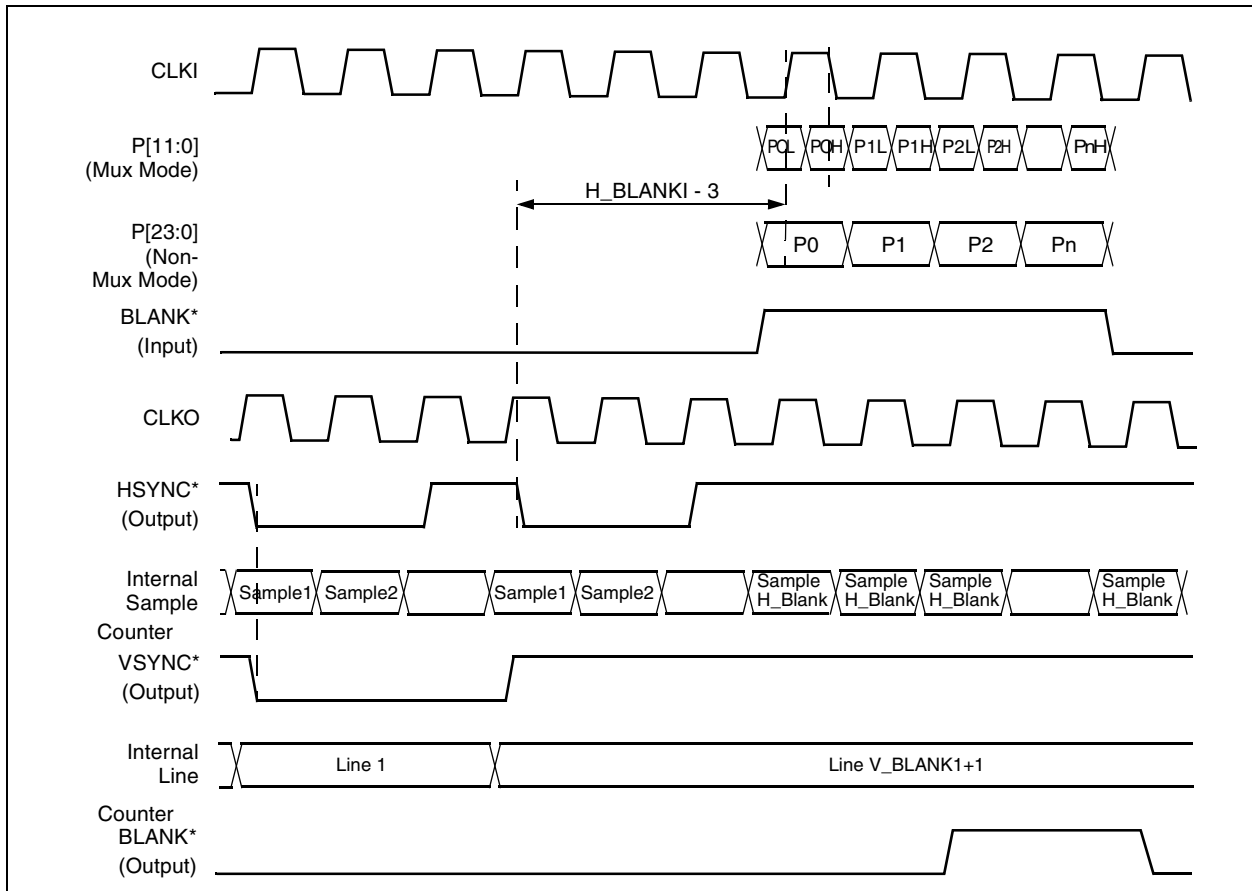
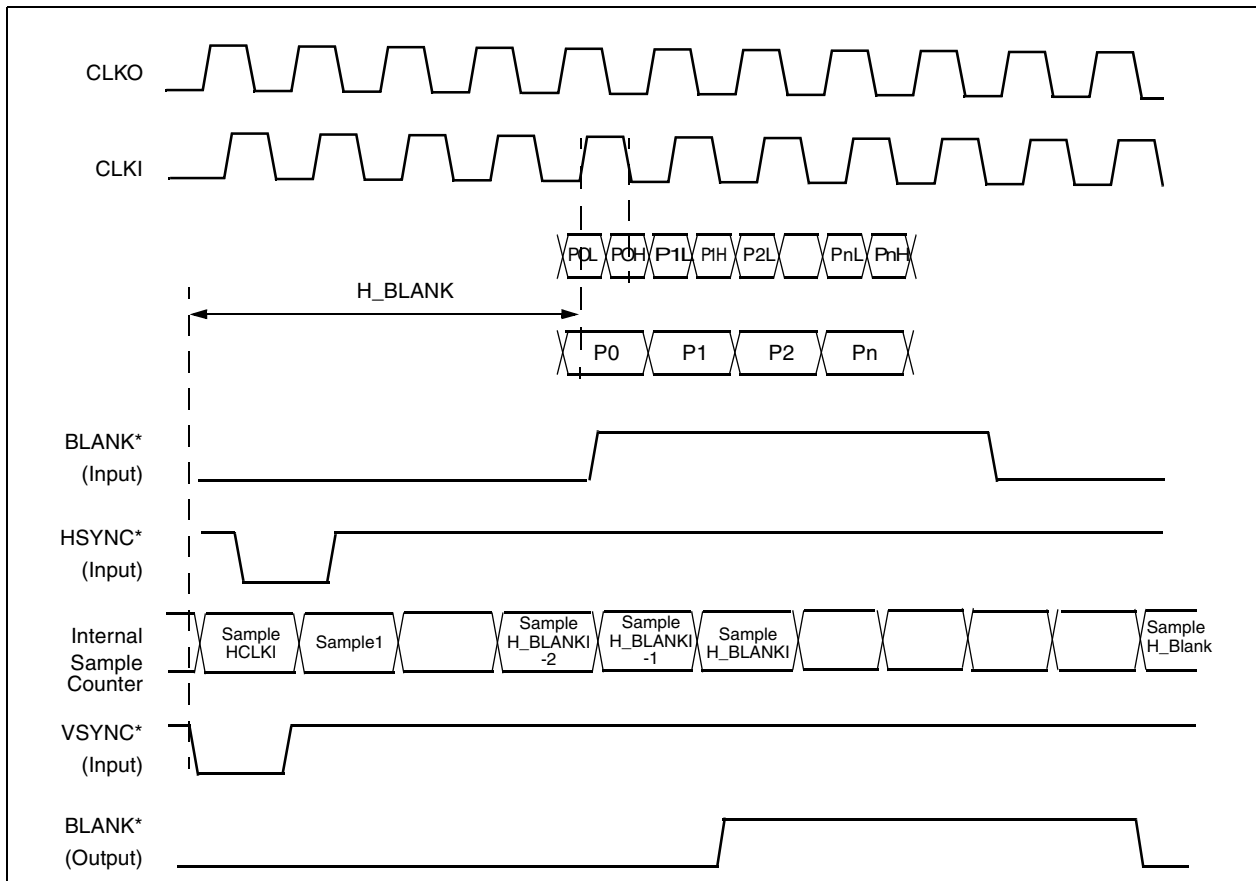

Figure 4-3. Slave Mode with Flicker Filter Interface Timing



4.3 Mechanical Drawing

A detailed mechanical diagram is shown in [Figure 0-1](#).

Figure 0-1. 80 MQFP Package Diagram

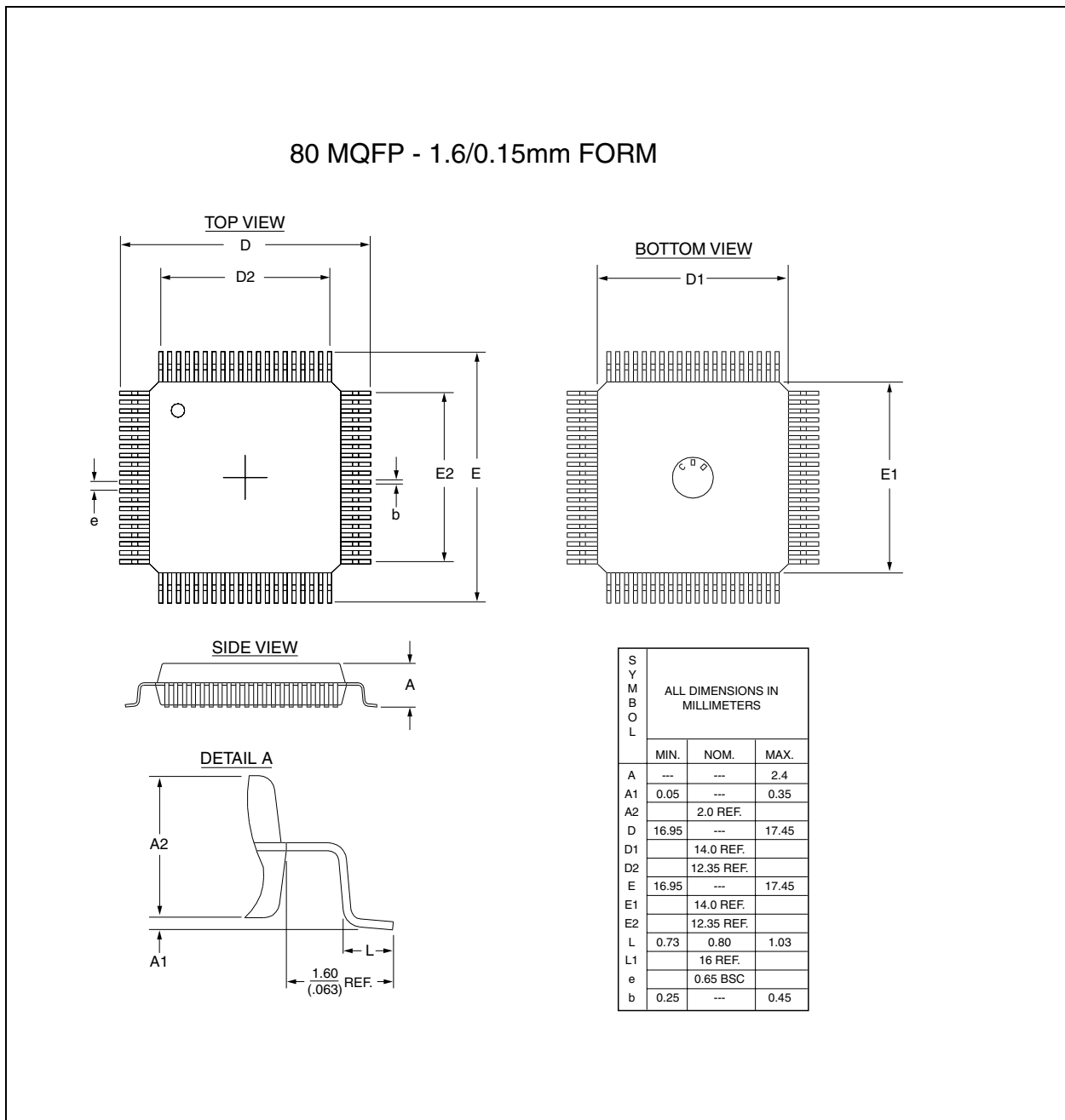

Table A-2. Constant Values Dependent on Encoding Mode

Modes	Interlaced		Non-Interlaced	
	PAL	NTSC	PAL	NTSC
ALO	288	243	288	243
TLO	312.5	262.5	312	262
ATO	52.0 μs	52.65556 μs	52.0 μs	52.65556 μs
TTO	64.0 μs	63.55556 μs	64.0 μs	63.55556 μs

Figure A-1. Overscan Compensation, 640x480 NTSC, 20 Clock Hblank

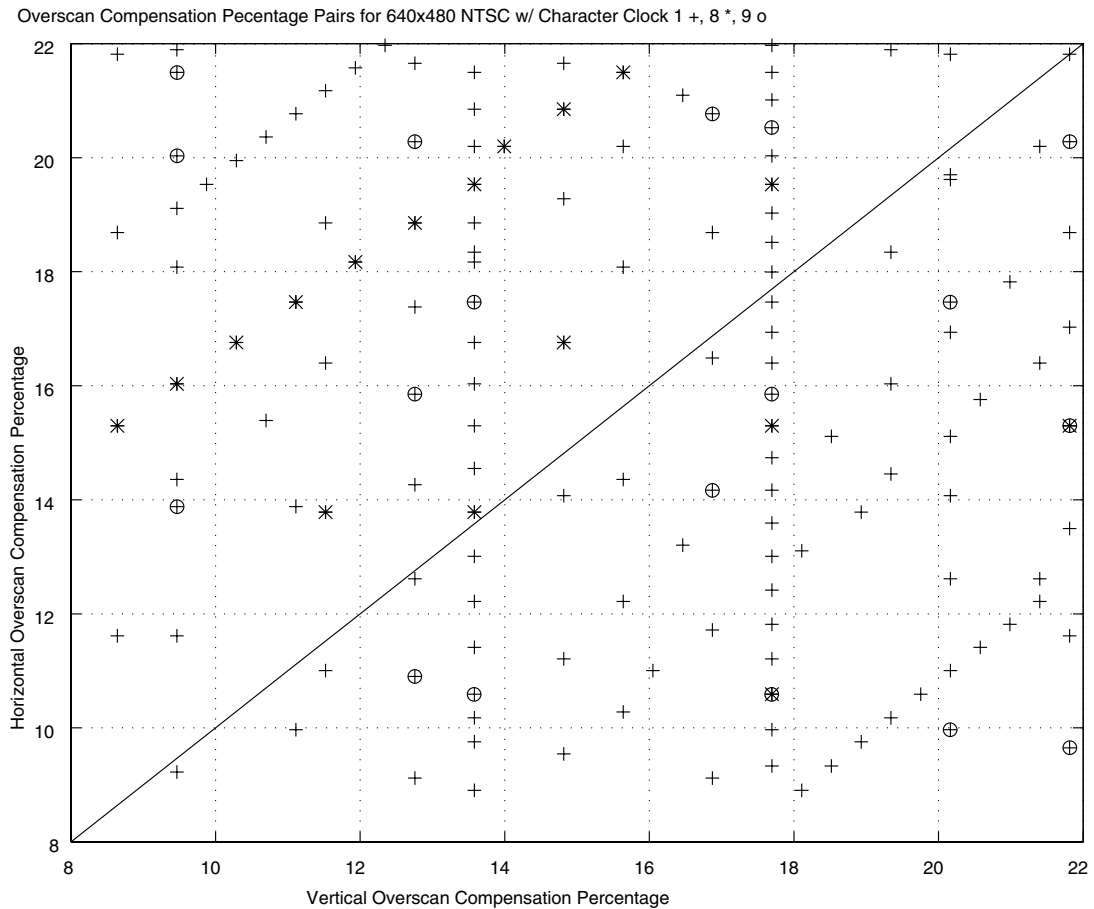

Figure A-2. Overscan Compensation, 640x480 PAL, 20 Clock Hblank

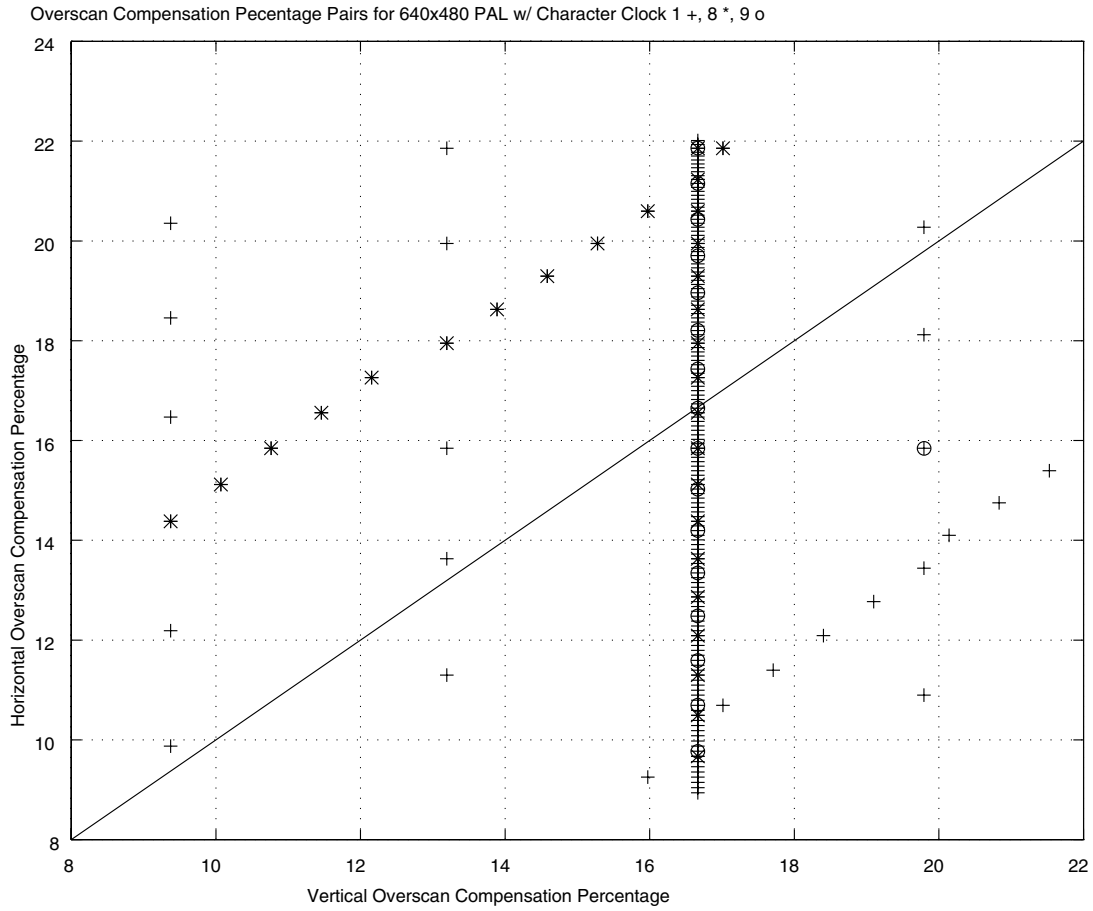

Figure A-3. Overscan Compensation, 800x600 NTSC

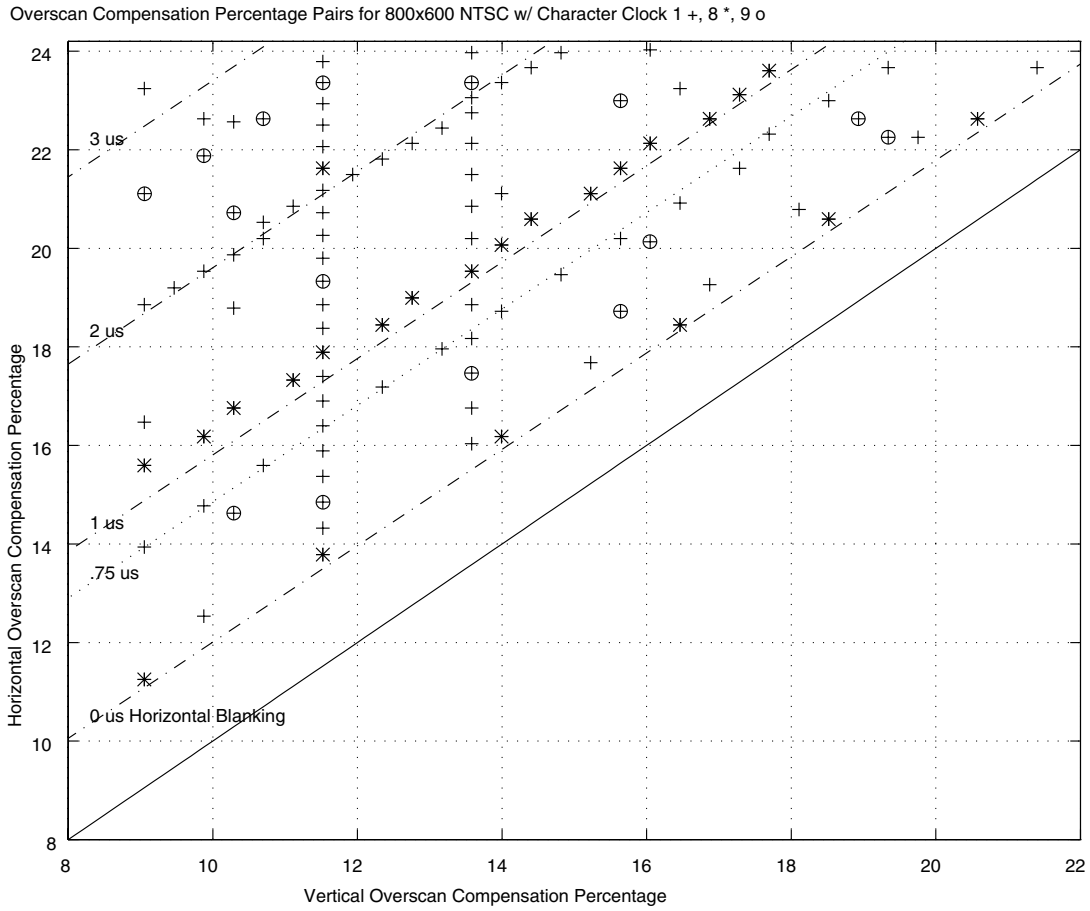

Figure A-4. Overscan Compensation, 800x600 PAL

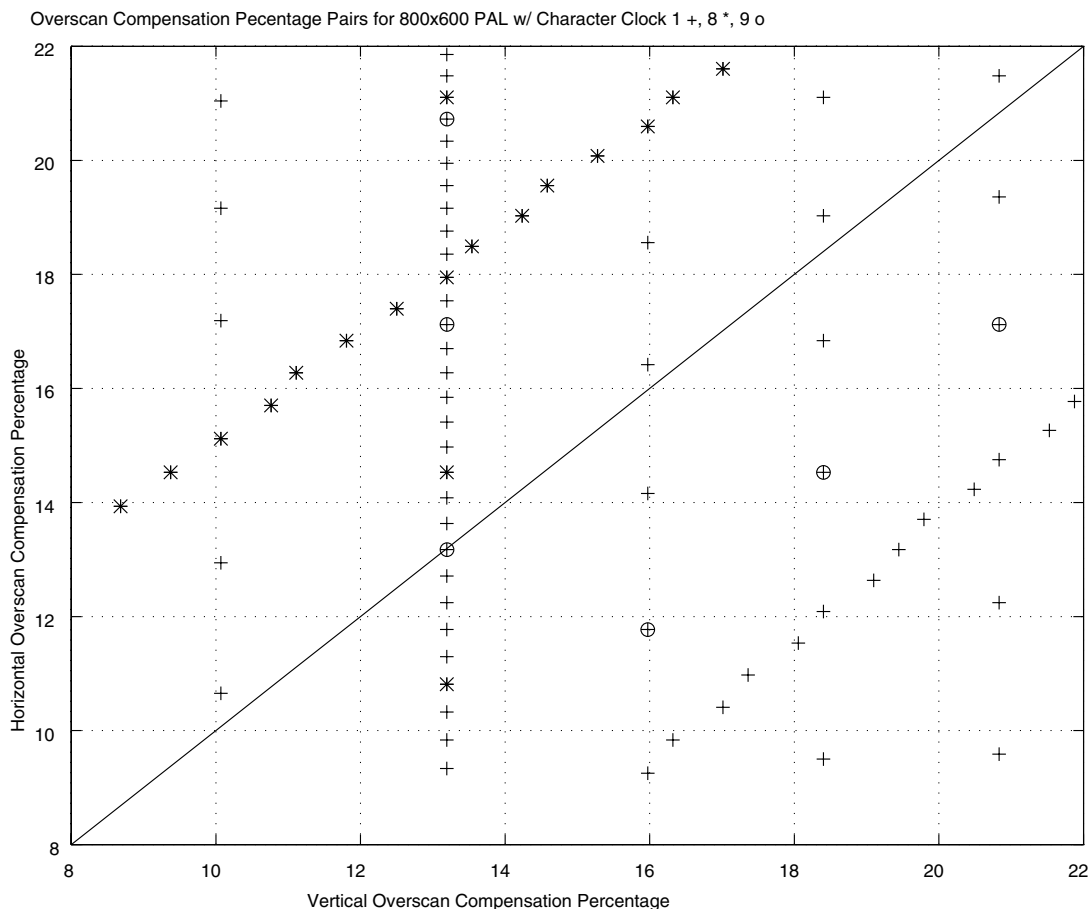

Table A-3. Overscan Values, 640x480 NTSC, 1 Pixel Resolution, 2.5 ms Hblank (1 of 3)

Controller Pixels		Encoder Pixels		Overscan (Percent)		
Total		Active	Total			
H_CLKI	V_LINESI	V_ACTIVEO	H_CLKO	H	V	Delta
780	665	190	988	21.81	21.81	0.00
780	595	212	884	12.61	12.76	-0.14
784	600	210	896	13.79	13.58	0.21
780	630	200	936	17.47	17.70	-0.23
777	575	220	851	9.23	9.47	-0.24
785	630	200	942	18.00	17.70	0.30
777	625	202	925	16.49	16.87	-0.38
777	650	194	962	19.70	20.16	-0.46
775	588	215	868	11.00	11.52	-0.52
775	651	194	961	19.62	20.16	-0.55

Table A-3. Overscan Values, 640x480 NTSC, 1 Pixel Resolution, 2.5 ms Hblank (2 of 3)

Controller Pixels		Encoder Pixels		Overscan (Percent)		
Total		Active	Total			
H_CLKI	V_LINESI	V_ACTIVEO	H_CLKO	H	V	Delta
777	600	210	888	13.01	13.58	-0.57
775	609	207	899	14.07	14.81	-0.74
775	630	200	930	16.94	17.70	-0.76
790	630	200	948	18.51	17.70	0.82
791	600	210	904	14.55	13.58	0.97
770	645	196	946	18.34	19.34	-1.00
770	585	216	858	9.97	11.11	-1.14
770	660	191	968	20.20	21.40	-1.20
770	615	205	902	14.36	15.64	-1.28
770	630	200	924	16.40	17.70	-1.30
795	630	200	954	19.03	17.70	1.33
770	600	210	880	12.22	13.58	-1.36
795	595	212	901	14.26	12.76	1.51
765	665	190	969	20.28	21.81	-1.53
798	650	194	988	21.81	20.16	1.65
798	600	210	912	15.30	13.58	1.72
798	625	202	950	18.69	16.87	1.81
800	630	200	960	19.53	17.70	1.84
765	630	200	918	15.85	17.70	-1.84
765	595	212	867	10.90	12.76	-1.86
800	609	207	928	16.76	14.81	1.94
798	575	220	874	11.62	9.47	2.15
763	600	210	872	11.41	13.58	-2.17
800	588	215	896	13.79	11.52	2.26
805	630	200	966	20.03	17.70	2.34
760	630	200	912	15.30	17.70	-2.40
805	615	205	943	18.08	15.64	2.44
805	600	210	920	16.03	13.58	2.45
805	645	196	989	21.89	19.34	2.55
756	650	194	936	17.47	20.16	-2.69

Flicker-Free Video Encoder with Ultrascale™ Technology

Table A-3. Overscan Values, 640x480 NTSC, 1 Pixel Resolution, 2.5 ms Hblank (3 of 3)

Controller Pixels		Encoder Pixels		Overscan (Percent)		
Total		Active	Total			
H_CLKI	V_LINESI	V_ACTIVEO	H_CLKO	H	V	Delta
756	625	202	900	14.17	16.87	-2.70
805	585	216	897	13.88	11.11	2.77
810	630	200	972	20.53	17.70	2.83
755	630	200	906	14.74	17.70	-2.96
805	570	222	874	11.62	8.64	2.97
756	600	210	864	10.59	13.58	-2.99

Table A-4. Overscan Values, 640x480 NTSC, 8 Pixel Resolution, 2.5 ms Hblank

Controller Pixels		Encoder Pixels		Overscan (Percent)		
Total		Active	Total			
H_CLKI	V_LINESI	V_ACTIVEO	H_CLKO	H	V	Delta
784	600	210	896	13.79	13.58	0.21
800	630	200	960	19.53	17.70	1.84
800	609	207	928	16.76	14.81	1.94
800	588	215	896	13.79	11.52	2.26
760	630	200	912	15.30	17.70	-2.40
840	615	205	984	21.50	15.64	5.86
840	600	210	960	19.53	13.58	5.95
840	610	207	976	20.85	14.81	6.04
840	595	212	952	18.86	12.76	6.10
840	605	209	968	20.20	13.99	6.21
840	590	214	944	18.17	11.93	6.23
840	585	216	936	17.47	11.11	6.36
840	580	218	928	16.76	10.29	6.47
720	665	190	912	15.30	21.81	-6.51
840	575	220	920	16.03	9.47	6.57
840	570	222	912	15.30	8.64	6.66
720	630	200	864	10.59	17.70	-7.10

Table A-5. Overscan Values, 640x480 NTSC, 9 Pixel Resolution, 2.5 ms Hblank

Controller Pixels		Encoder Pixels		Overscan (Percent)		
Total		Active	Total			
H	V	V	H	H	V	Delta
765	665	190	969	20.28	21.81	-1.53
765	630	200	918	15.85	17.70	-1.84
765	595	212	867	10.90	12.76	-1.86
756	650	194	936	17.47	20.16	-2.69
756	625	202	900	14.17	16.87	-2.70
810	630	200	972	20.53	17.70	2.83
756	600	210	864	10.59	13.58	-2.99
810	595	212	918	15.85	12.76	3.09
819	600	210	936	17.47	13.58	3.89
819	625	202	975	20.77	16.87	3.90
819	575	220	897	13.88	9.47	4.42
720	665	190	912	15.30	21.81	-6.51
720	630	200	864	10.59	17.70	-7.10
855	595	212	969	20.28	12.76	7.52
693	650	194	858	9.97	20.16	-10.20
882	575	220	966	20.03	9.47	10.57
900	574	220	984	21.50	9.47	12.03
675	665	190	855	9.65	21.81	-12.16

Table A-6. Overscan Values, 640x480 PAL, 1 Pixel Resolution, 2.5 ms Hblank (1 of 4)

Controller Pixels		Encoder Pixels		Overscan (Percent)		
Total		Active	Total			
H	V	V	H	H	V	Delta
945	625	240	945	16.65	16.67	-0.02
946	625	240	946	16.73	16.67	0.07
944	625	240	944	16.56	16.67	-0.11
947	625	240	947	16.82	16.67	0.16
943	625	240	943	16.47	16.67	-0.20
948	625	240	948	16.91	16.67	0.24
942	625	240	942	16.38	16.67	-0.29
949	625	240	949	17.00	16.67	0.33

Flicker-Free Video Encoder with Ultrascale™ Technology

Table A-6. Overscan Values, 640x480 PAL, 1 Pixel Resolution, 2.5 ms Hblank (2 of 4)

Controller Pixels		Encoder Pixels		Overscan (Percent)		
Total		Active	Total			
H	V	V	H	H	V	Delta
941	625	240	941	16.29	16.67	-0.37
950	625	240	950	17.09	16.67	0.42
950	600	250	912	13.63	13.19	0.44
940	625	240	940	16.20	16.67	-0.46
950	650	231	988	20.27	19.79	0.48
950	575	261	874	9.88	9.38	0.50
951	625	240	951	17.17	16.67	0.51
939	625	240	939	16.11	16.67	-0.55
952	625	240	952	17.26	16.67	0.59
938	625	240	938	16.02	16.67	-0.64
953	625	240	953	17.35	16.67	0.68
937	625	240	937	15.93	16.67	-0.73
954	625	240	954	17.43	16.67	0.77
936	625	240	936	15.84	16.67	-0.82
955	625	240	955	17.52	16.67	0.85
935	625	240	935	15.75	16.67	-0.91
956	625	240	956	17.61	16.67	0.94
934	625	240	934	15.66	16.67	-1.00
957	625	240	957	17.69	16.67	1.02
933	625	240	933	15.57	16.67	-1.09
958	625	240	958	17.78	16.67	1.11
932	625	240	932	15.48	16.67	-1.18
959	625	240	959	17.86	16.67	1.20
931	625	240	931	15.39	16.67	-1.27
960	625	240	960	17.95	16.67	1.28
930	625	240	930	15.30	16.67	-1.36
961	625	240	961	18.03	16.67	1.37
962	625	240	962	18.12	16.67	1.45
929	625	240	929	15.21	16.67	-1.46
963	625	240	963	18.20	16.67	1.54
928	625	240	928	15.12	16.67	-1.55
964	625	240	964	18.29	16.67	1.62

Table A-6. Overscan Values, 640x480 PAL, 1 Pixel Resolution, 2.5 ms Hblank (3 of 4)

Controller Pixels		Encoder Pixels		Overscan (Percent)		
Total		Active	Total			
H	V	V	H	H	V	Delta
927	625	240	927	15.03	16.67	-1.64
925	650	231	962	18.12	19.79	-1.67
965	625	240	965	18.37	16.67	1.71
926	625	240	926	14.94	16.67	-1.73
966	625	240	966	18.46	16.67	1.79
925	625	240	925	14.84	16.67	-1.82
967	625	240	967	18.54	16.67	1.88
925	600	250	888	11.30	13.19	-1.90
924	625	240	924	14.75	16.67	-1.91
968	625	240	968	18.63	16.67	1.96
923	625	240	923	14.66	16.67	-2.01
969	625	240	969	18.71	16.67	2.04
922	625	240	922	14.57	16.67	-2.10
970	625	240	970	18.79	16.67	2.13
921	625	240	921	14.47	16.67	-2.19
971	625	240	971	18.88	16.67	2.21
920	625	240	920	14.38	16.67	-2.29
972	625	240	972	18.96	16.67	2.30
973	625	240	973	19.04	16.67	2.38
919	625	240	919	14.29	16.67	-2.38
974	625	240	974	19.13	16.67	2.46
918	625	240	918	14.19	16.67	-2.47
975	625	240	975	19.21	16.67	2.54
917	625	240	917	14.10	16.67	-2.57
976	625	240	976	19.29	16.67	2.63
975	600	250	936	15.84	13.19	2.65
916	625	240	916	14.01	16.67	-2.66
977	625	240	977	19.38	16.67	2.71
915	625	240	915	13.91	16.67	-2.75

Flicker-Free Video Encoder with Ultrascale™ Technology

Table A-6. Overscan Values, 640x480 PAL, 1 Pixel Resolution, 2.5 ms Hblank (4 of 4)

Controller Pixels		Encoder Pixels		Overscan (Percent)		
Total		Active	Total			
H	V	V	H	H	V	Delta
978	625	240	978	19.46	16.67	2.79
975	575	261	897	12.19	9.38	2.81
914	625	240	914	13.82	16.67	-2.85
979	625	240	979	19.54	16.67	2.87
913	625	240	913	13.72	16.67	-2.94
980	625	240	980	19.62	16.67	2.96

Table A-7. Overscan Values, 640x480 PAL, 8 Pixel Resolution, 2.5 ms Hblank (1 of 2)

Controller Pixels		Encoder Pixels		Overscan (Percent)		
Total		Active	Total			
H	V	V	H	H	V	Delta
944	625	240	944	16.56	16.67	-0.11
952	625	240	952	17.26	16.67	0.59
936	625	240	936	15.84	16.67	-0.82
960	625	240	960	17.95	16.67	1.28
928	625	240	928	15.12	16.67	-1.55
968	625	240	968	18.63	16.67	1.96
920	625	240	920	14.38	16.67	-2.29
976	625	240	976	19.29	16.67	2.63
912	625	240	912	13.63	16.67	-3.04
984	625	240	984	19.95	16.67	3.28
904	625	240	904	12.87	16.67	-3.80
992	625	240	992	20.60	16.67	3.93
1000	625	240	1000	21.23	16.67	4.56
896	625	240	896	12.09	16.67	-4.58
1000	620	242	992	20.60	15.97	4.62
1000	615	244	984	19.95	15.28	4.67
1000	610	246	976	19.29	14.58	4.71
1000	605	248	968	18.63	13.89	4.74
1000	600	250	960	17.95	13.19	4.75
1000	630	239	1008	21.86	17.01	4.84
1000	575	261	920	14.38	9.38	5.01

Table A-7. Overscan Values, 640x480 PAL, 8 Pixel Resolution, 2.5 ms Hblank (2 of 2)

Controller Pixels		Encoder Pixels		Overscan (Percent)		
Total		Active	Total			
H	V	V	H	H	V	Delta
1000	580	259	928	15.12	10.07	5.05
1000	585	257	936	15.84	10.76	5.08
1000	590	255	944	16.56	11.46	5.10
1000	595	253	952	17.26	12.15	5.11
1008	625	240	1008	21.86	16.67	5.19
888	625	240	888	11.30	16.67	-5.37
880	625	240	880	10.49	16.67	-6.18
872	625	240	872	9.67	16.67	-7.00

Table A-8. Overscan Values, 640x480 PAL, 9 Pixel Resolution, 2.5 ms Hblank

Controller Pixels		Encoder Pixels		Overscan (Percent)		
Total		Active	Total			
H	V	V	H	H	V	Delta
945	625	240	945	16.65	16.67	-0.02
954	625	240	954	17.43	16.67	0.77
936	625	240	936	15.84	16.67	-0.82
963	625	240	963	18.20	16.67	1.54
927	625	240	927	15.03	16.67	-1.64
972	625	240	972	18.96	16.67	2.30
918	625	240	918	14.19	16.67	-2.47
981	625	240	981	19.71	16.67	3.04
909	625	240	909	13.35	16.67	-3.32
990	625	240	990	20.44	16.67	3.77
900	650	231	936	15.84	19.79	-3.95
900	625	240	900	12.48	16.67	-4.19
999	625	240	999	21.15	16.67	4.49
891	625	240	891	11.59	16.67	-5.07
1008	625	240	1008	21.86	16.67	5.19
882	625	240	882	10.69	16.67	-5.97
873	625	240	873	9.77	16.67	-6.89

Table A-9. Overscan Values, 800x600 NTSC (1 of 5)

Controller Pixels		Encoder Pixels		Overscan (Percent)			Hblank and Character Clock Resolution	
Total		Active	Total	H	V	Delta	Hblank	Resol
H	V	V	H					
800	777	203	1184	18.45	16.46	1.98	0.00	1
800	819	193	1248	22.63	20.58	2.05	0.00	1
800	798	198	1216	20.59	18.52	2.07	0.00	1
800	756	209	1152	16.18	13.99	2.19	0.00	1
800	714	221	1088	11.25	9.05	2.20	0.00	1
800	735	215	1120	13.79	11.52	2.26	0.00	1
805	825	191	1265	23.67	21.40	2.27	0.13	1
805	780	202	1196	19.26	16.87	2.39	0.13	1
805	750	210	1150	16.03	13.58	2.45	0.14	1
805	765	206	1173	17.68	15.23	2.45	0.14	1
805	810	195	1242	22.25	19.75	2.50	0.13	1
805	720	219	1104	12.54	9.88	2.66	0.14	1
805	795	199	1219	20.79	18.11	2.68	0.13	1
805	735	215	1127	14.32	11.52	2.80	0.14	1
810	805	196	1242	22.25	19.34	2.91	0.26	1
810	770	205	1188	18.72	15.64	3.08	0.27	1
812	750	210	1160	16.76	13.58	3.18	0.33	1
810	735	215	1134	14.85	11.52	3.33	0.28	1
819	800	197	1248	22.63	18.93	3.70	0.48	1
815	735	215	1141	15.37	11.52	3.85	0.42	1
819	750	210	1170	17.47	13.58	3.89	0.52	1
819	775	204	1209	20.13	16.05	4.08	0.50	1
825	805	196	1265	23.67	19.34	4.33	0.63	1
819	725	218	1131	14.62	10.29	4.34	0.53	1
825	784	201	1232	21.62	17.28	4.34	0.64	1
820	735	215	1148	15.89	11.52	4.37	0.55	1
825	777	203	1221	20.92	16.46	4.46	0.65	1
825	798	198	1254	23.00	18.52	4.48	0.63	1
825	770	205	1210	20.20	15.64	4.56	0.66	1
826	750	210	1180	18.17	13.58	4.59	0.70	1
825	791	200	1243	22.32	17.70	4.62	0.64	1
825	763	207	1199	19.47	14.81	4.65	0.66	1

Table A-9. Overscan Values, 800x600 NTSC (2 of 5)

Controller Pixels		Encoder Pixels		Overscan (Percent)			Hblank and Character Clock Resolution	
Total		Active	Total	H	V	Delta	Hblank	Resol
H	V	V	H	H	V	Delta	Hblank	Resol
825	756	209	1188	18.72	13.99	4.73	0.67	1
825	749	211	1177	17.96	13.17	4.79	0.67	1
825	742	213	1166	17.19	12.35	4.84	0.68	1
825	735	215	1155	16.40	11.52	4.88	0.69	1
825	714	221	1122	13.94	9.05	4.89	0.71	1
825	728	217	1144	15.59	10.70	4.89	0.69	1
825	721	219	1133	14.77	9.88	4.90	0.70	1
833	750	210	1190	18.86	13.58	5.28	0.88	1
830	735	215	1162	16.90	11.52	5.38	0.82	1
840	780	202	1248	22.63	16.87	5.76	1.02	1
840	785	201	1256	23.12	17.28	5.84	1.01	1
835	735	215	1169	17.40	11.52	5.88	0.95	1
840	765	206	1224	21.11	15.23	5.88	1.04	1
840	790	200	1264	23.61	17.70	5.91	1.01	1
840	750	210	1200	19.53	13.58	5.95	1.06	1
840	770	205	1232	21.62	15.64	5.99	1.03	1
840	755	209	1208	20.07	13.99	6.07	1.05	1
840	775	204	1240	22.13	16.05	6.08	1.03	1
840	740	213	1184	18.45	12.35	6.10	1.07	1
840	760	208	1216	20.59	14.40	6.19	1.05	1
840	730	216	1168	17.33	11.11	6.22	1.09	1
840	745	212	1192	18.99	12.76	6.24	1.07	1
840	720	219	1152	16.18	9.88	6.30	1.10	1
840	735	215	1176	17.89	11.52	6.37	1.08	1
840	725	218	1160	16.76	10.29	6.47	1.10	1
840	715	221	1144	15.59	9.05	6.54	1.11	1
847	750	210	1210	20.20	13.58	6.62	1.23	1
850	777	203	1258	23.24	16.46	6.78	1.26	1
845	735	215	1183	18.38	11.52	6.85	1.21	1
850	756	209	1224	21.11	13.99	7.12	1.30	1
854	750	210	1220	20.85	13.58	7.27	1.41	1
850	735	215	1190	18.86	11.52	7.33	1.34	1

Flicker-Free Video Encoder with Ultrascale™ Technology

Table A-9. Overscan Values, 800x600 NTSC (3 of 5)

Controller Pixels		Encoder Pixels		Overscan (Percent)			Hblank and Character Clock Resolution	
Total		Active	Total	H	V	Delta	Hblank	Resol
H	V	V	H	H	V	Delta	Hblank	Resol
855	770	205	1254	23.00	15.64	7.36	1.39	1
850	714	221	1156	16.47	9.05	7.42	1.37	1
855	735	215	1197	19.33	11.52	7.81	1.46	1
861	750	210	1230	21.50	13.58	7.92	1.58	1
861	775	204	1271	24.03	16.05	7.98	1.53	1
860	735	215	1204	19.80	11.52	8.28	1.58	1
861	725	218	1189	18.79	10.29	8.50	1.63	1
868	750	210	1240	22.13	13.58	8.55	1.74	1
865	735	215	1211	20.26	11.52	8.74	1.71	1
875	762	207	1270	23.97	14.81	9.15	1.88	1
875	750	210	1250	22.75	13.58	9.17	1.91	1
870	735	215	1218	20.72	11.52	9.20	1.83	1
875	759	208	1265	23.67	14.40	9.26	1.88	1
875	747	211	1245	22.44	13.17	9.27	1.91	1
875	744	212	1240	22.13	12.76	9.37	1.92	1
875	756	209	1260	23.36	13.99	9.37	1.89	1
875	741	213	1235	21.81	12.35	9.47	1.93	1
875	753	210	1255	23.06	13.58	9.48	1.90	1
875	726	217	1210	20.20	10.70	9.50	1.97	1
875	738	214	1230	21.50	11.93	9.56	1.94	1
875	723	218	1205	19.87	10.29	9.58	1.98	1
875	735	215	1225	21.18	11.52	9.65	1.95	1
875	720	219	1200	19.53	9.88	9.66	1.99	1
875	717	220	1195	19.20	9.47	9.73	1.99	1
875	732	216	1220	20.85	11.11	9.74	1.95	1
882	750	210	1260	23.36	13.58	9.78	2.07	1
875	714	221	1190	18.86	9.05	9.80	2.00	1
875	729	217	1215	20.53	10.70	9.83	1.96	1
880	735	215	1232	21.62	11.52	10.10	2.06	1
889	750	210	1270	23.97	13.58	10.39	2.23	1
882	725	218	1218	20.72	10.29	10.43	2.14	1
885	735	215	1239	22.07	11.52	10.54	2.18	1

Table A-9. Overscan Values, 800x600 NTSC (4 of 5)

Controller Pixels		Encoder Pixels		Overscan (Percent)			Hblank and Character Clock Resolution	
Total		Active	Total	H	V	Delta	Hblank	Resol
H	V	V	H	H	V	Delta	Hblank	Resol
890	735	215	1246	22.50	11.52	10.98	2.30	1
895	735	215	1253	22.94	11.52	11.41	2.41	1
900	735	215	1260	23.36	11.52	11.84	2.52	1
900	728	217	1248	22.63	10.70	11.93	2.55	1
900	721	219	1236	21.88	9.88	12.00	2.57	1
900	714	221	1224	21.11	9.05	12.06	2.60	1
905	735	215	1267	23.79	11.52	12.27	2.63	1
903	725	218	1247	22.57	10.29	12.28	2.62	1
910	720	219	1248	22.63	9.88	12.75	2.80	1
925	714	221	1258	23.24	9.05	14.19	3.16	1
800	777	203	1184	18.45	16.46	1.98	0.00	8
800	819	193	1248	22.63	20.58	2.05	0.00	8
800	798	198	1216	20.59	18.52	2.07	0.00	8
800	756	209	1152	16.18	13.99	2.19	0.00	8
800	714	221	1088	11.25	9.05	2.20	0.00	8
800	735	215	1120	13.79	11.52	2.26	0.00	8
840	780	202	1248	22.63	16.87	5.76	1.02	8
840	785	201	1256	23.12	17.28	5.84	1.01	8
840	765	206	1224	21.11	15.23	5.88	1.04	8
840	790	200	1264	23.61	17.70	5.91	1.01	8
840	750	210	1200	19.53	13.58	5.95	1.06	8
840	770	205	1232	21.62	15.64	5.99	1.03	8
840	755	209	1208	20.07	13.99	6.07	1.05	8
840	775	204	1240	22.13	16.05	6.08	1.03	8
840	740	213	1184	18.45	12.35	6.10	1.07	8
840	760	208	1216	20.59	14.40	6.19	1.05	8
840	730	216	1168	17.33	11.11	6.22	1.09	8
840	745	212	1192	18.99	12.76	6.24	1.07	8
840	720	219	1152	16.18	9.88	6.30	1.10	8
840	735	215	1176	17.89	11.52	6.37	1.08	8
840	725	218	1160	16.76	10.29	6.47	1.10	8
840	715	221	1144	15.59	9.05	6.54	1.11	8

Table A-9. Overscan Values, 800x600 NTSC (5 of 5)

Controller Pixels		Encoder Pixels		Overscan (Percent)			Hblank and Character Clock Resolution	
Total		Active	Total					
H	V	V	H	H	V	Delta	Hblank	Resol
880	735	215	1232	21.62	11.52	10.10	2.06	8
810	805	196	1242	22.25	19.34	2.91	0.26	9
810	770	205	1188	18.72	15.64	3.08	0.27	9
810	735	215	1134	14.85	11.52	3.33	0.28	9
819	800	197	1248	22.63	18.93	3.70	0.48	9
819	750	210	1170	17.47	13.58	3.89	0.52	9
819	775	204	1209	20.13	16.05	4.08	0.50	9
819	725	218	1131	14.62	10.29	4.34	0.53	9
855	770	205	1254	23.00	15.64	7.36	1.39	9
855	735	215	1197	19.33	11.52	7.81	1.46	9
882	750	210	1260	23.36	13.58	9.78	2.07	9
882	725	218	1218	20.72	10.29	10.43	2.14	9
900	735	215	1260	23.36	11.52	11.84	2.52	9
900	728	217	1248	22.63	10.70	11.93	2.55	9
900	721	219	1236	21.88	9.88	12.00	2.57	9
900	714	221	1224	21.11	9.05	12.06	2.60	9

Table A-10. Overscan Values, 800x600, PAL, > 2.5 ms Hblank (1 of 3)

Controller Pixels		Encoder Pixels		Overscan (Percent)			Character Clock
Total		Active	Total				
H	V	V	H	H	V	Delta	Resol
945	750	250	1134	13.17	13.19	-0.02	1
950	750	250	1140	13.63	13.19	0.44	1
950	775	242	1178	16.42	15.97	0.44	1
940	750	250	1128	12.71	13.19	-0.48	1
950	725	259	1102	10.65	10.07	0.58	1
950	800	235	1216	19.03	18.40	0.63	1
950	825	228	1254	21.48	20.83	0.65	1
955	750	250	1146	14.08	13.19	0.89	1
935	750	250	1122	12.24	13.19	-0.95	1
960	750	250	1152	14.53	13.19	1.34	1
930	750	250	1116	11.77	13.19	-1.42	1

Table A-10. Overscan Values, 800x600, PAL, > 2.5 ms Hblank (2 of 3)

Controller Pixels		Encoder Pixels		Overscan (Percent)			Character Clock
Total		Active	Total	H	V	Delta	Resol
H	V	V	H	H	V	Delta	Resol
925	825	228	1221	19.36	20.83	-1.47	1
925	800	235	1184	16.84	18.40	-1.56	1
965	750	250	1158	14.97	13.19	1.78	1
925	775	242	1147	14.16	15.97	-1.81	1
925	750	250	1110	11.30	13.19	-1.90	1
970	750	250	1164	15.41	13.19	2.22	1
920	750	250	1104	10.81	13.19	-2.38	1
975	775	242	1209	18.56	15.97	2.59	1
975	750	250	1170	15.84	13.19	2.65	1
975	800	235	1248	21.10	18.40	2.70	1
915	750	250	1098	10.33	13.19	-2.87	1
975	725	259	1131	12.94	10.07	2.87	1
980	750	250	1176	16.27	13.19	3.08	1
910	750	250	1092	9.83	13.19	-3.36	1
985	750	250	1182	16.70	13.19	3.50	1
900	825	228	1188	17.12	20.83	-3.71	1
905	750	250	1086	9.34	13.19	-3.86	1
900	800	235	1152	14.53	18.40	-3.87	1
990	750	250	1188	17.12	13.19	3.93	1
900	775	242	1116	11.77	15.97	-4.20	1
995	750	250	1194	17.54	13.19	4.34	1
1000	785	239	1256	21.61	17.01	4.59	1
1000	775	242	1240	20.60	15.97	4.62	1
1000	750	250	1200	17.95	13.19	4.75	1
1000	780	241	1248	21.10	16.32	4.79	1
1000	760	247	1216	19.03	14.24	4.79	1
1000	770	244	1232	20.08	15.28	4.80	1
1000	745	252	1192	17.40	12.50	4.90	1
1000	730	257	1168	15.70	10.76	4.94	1
1000	755	249	1208	18.49	13.54	4.95	1
1000	765	246	1224	19.56	14.58	4.97	1
960	750	250	1152	14.53	13.19	1.34	8

Flicker-Free Video Encoder with Ultrascale™ Technology

Table A-10. Overscan Values, 800x600, PAL, > 2.5 ms Hblank (3 of 3)

Controller Pixels		Encoder Pixels		Overscan (Percent)			Character Clock
Total		Active	Total	H	V	Delta	Resol
H	V	V	H	H	V	Delta	Resol
920	750	250	1104	10.81	13.19	-2.38	8
1000	785	239	1256	21.61	17.01	4.59	8
1000	775	242	1240	20.60	15.97	4.62	8
1000	750	250	1200	17.95	13.19	4.75	8
1000	780	241	1248	21.10	16.32	4.79	8
1000	760	247	1216	19.03	14.24	4.79	8
1000	770	244	1232	20.08	15.28	4.80	8
1000	745	252	1192	17.40	12.50	4.90	8
1000	730	257	1168	15.70	10.76	4.94	8
1000	755	249	1208	18.49	13.54	4.95	8
1000	765	246	1224	19.56	14.58	4.97	8
1000	740	254	1184	16.84	11.81	5.03	8
1000	725	259	1160	15.12	10.07	5.05	8
1000	720	261	1152	14.53	9.38	5.15	8
1000	735	256	1176	16.27	11.11	5.16	8
1000	715	263	1144	13.93	8.68	5.25	8
1040	750	250	1248	21.10	13.19	7.91	8
945	750	250	1134	13.17	13.19	-0.02	9
900	825	228	1188	17.12	20.83	-3.71	9
900	800	235	1152	14.53	18.40	-3.87	9
990	750	250	1188	17.12	13.19	3.93	9
900	775	242	1116	11.77	15.97	-4.20	9
1035	750	250	1242	20.72	13.19	7.53	9

Appendix B. Approved Crystal Vendors

Conexant conducted a series of internal tests and used the results to generate this list of approved crystal vendors. Contact your local Conexant Field Applications Engineer for additional details.

Standard Crystal (El Monte, CA)

Phone Number: (626)443-2121
FAX Number: (626)443-9049
E-mail: stdxtl@worldnet.att.net

Part Numbers for 13.500 MHz, Fundamental, 20pF Load Crystal with an HC49U Type of Package:

Full Height/50 ppm Total Tolerance: AAK13M500000GXE20A
Half-Height/50 ppm: AAL13M500000GXE20A
Full Height/25 ppm: Did Not Qualify

MMD Components (Irvine, CA)

Phone Number: (949)753-5888
FAX Number: (949)753-5889
E-mail: mmdcomp@earthlink.net

Part Numbers for 13.500 MHz, Fundamental, 20pF Load Crystal with an HC49U Type of Package:

Full Height/50ppm Total Tolerance: A20BA1-13.500 MHz.
Half-Height/50 ppm: B20BA1-13,500 MHz
Full Height/25 ppm: Did Not Qualify

General Electronics (San Marcos, CA)

Phone Number: (760)591-4170
FAX Number: (760)591-4164
E-mail: gedlm@4dcomm.com

Part Numbers for 13.500 MHz, Fundamental, 20pF Load Crystal with an HC49U Type of Package:

Full Height/50 ppm Total Tolerance: PKHC49/U-13.500-.020-.005
Half-Height/50 ppm: PKHC49/US-13.500-.020-.005
Full Height/25 ppm: PKHC49/U-13.500-.0025-15R

Fox Electronics (Fort Myers, FL)

Phone Number: (941)693-0099
FAX Number: (941)693-1554
E-mail: barbc@foxonline.com

Part Numbers for 13.500 MHz, Fundamental, 20pF Load Crystal with an HC49U Type of Package:

Full Height/50 ppm Total Tolerance: HC49U-13.500 MHz-/50/0/70/20 pF
Half Height/50 ppm: HC49S 13.500-/50/0/70/20 pF
Full Height/25 ppm: HC49U 13.500-/25/0/70/20 pF

Bomar (Middlesex, NJ)

Phone Number: (732)356-7787
FAX Number: (732)356-7362
E-mail: sales@bomarcystal.com
Part Numbers for 13.500 MHz, Fundamental, 20pF Load Crystal with an HC49U Type of Package:
Full Height/50 ppm Total Tolerance: BRC1C14F-13.50000
Half Height/50 ppm: ACR-49S012025-13.50000
Full Height/25 ppm: BRCIE14F-13.50000

HY-Q (Erlanger, Kentucky)

Phone Number: (606)283-5000
FAX Number: (606)283-0883
E-mail: Cpainter@hyqusa.com
Part Numbers for 13.500 MHz, Fundamental, 20pF Load Crystal with an HC49U Type of Package:
Full Height/50 ppm Total Tolerance: HT81818/01
Half Height/50 ppm: SC30002/01
Full Height/25 ppm: HT81819/01

ILSI America (Kirkland, WA)

Phone Number: (425)828-4886 / (888)355-4574
FAX Number: (425)828-4878
E-mail: ilsiam@ilsiamerica.co
Part Numbers for 13.500 MHz, Fundamental, 20pF Load Crystal with an HC49U Type of Package:
Full Height/50 ppm Total Tolerance: HC49U-25/25-13.500-20
Half Height/50 ppm: HC49US-FB1F20-13.500
Full Height/25 ppm: Did Not Qualify

Cardinal Components (Wayne, NJ)

Phone Number: (973)785-1333
FAX Number: (973)785-0053
E-mail: dbabcock@cardinalxtal.com
Part Numbers for 13.500 MHz, Fundamental, 20pF Load Crystal with an HC49U Type of Package:
Full Height/50 ppm Total Tolerance: C49-A4BRC7-25-13.5D20
Half Height/50 ppm: CLP-A4B6C4-50-13.5D20
Full Height/25 ppm: C49-A4B6C4-25-13.5D20

Raltron Electronics Corp. (Miami, FL)

Phone Number: (305)593-6033
FAX Number: (305)594-3973
E-mail: maria@raltron.com
Part Numbers for 13.500 MHz, Fundamental, 20pF Load Crystal with an HC49U Type of Package:
Full Height/50 ppm Total Tolerance: A-13.500-20-RS1
Half Height/50 ppm: AS-13.500-20-RS1
Full Height/25 ppm: A-13.500-20-RS1

Valpey-Fisher (Hopkinton, MA)

Phone Number: (800)982-5737
FAX Number: (508)497-6377

Flicker-Free Video Encoder with Ultrascale™ Technology

E-mail: angleassoc@aol.com
Part Numbers for 13.500 MHz, Fundamental, 20pF Load Crystal with an HC49U Type of Package:
 Full Height/50 ppm Total Tolerance: M490013.500020RSVM
 Half Height/50 ppm: M49K013.50002099VM
 Full Height/25 ppm: M490013.50002099VM

Telequarz Group (Germany)

Phone Number: Telequarz-USA Inc. (Ft. Mill, SC): (803)547-0770
 FAX Number: (507)547-0775
 E-mail: info@telequarz.de
Part Numbers for 13.500 MHz, Fundamental, 20pF Load Crystal with an HC49U Type of Package:
 Full Height/50 ppm Total Tolerance: TQ RSD 13.5FH50
 Half Height/50 ppm: TQRSD 13.5LP50
 Full Height/25 ppm: TQ RSD 13.5FH25

**Further Information**

literature@conexant.com
(800) 854-8099 (North America)
(949) 483-6996 (International)
Printed in USA

World Headquarters

Conexant Systems, Inc.
4311 Jamboree Road
Newport Beach, CA
92660-3007
Phone: (949) 483-4600
Fax 1: (949) 483-4078
Fax 2: (949) 483-4391

Americas**U.S. Northwest/****Pacific Northwest – Santa Clara**

Phone: (408) 249-9696
Fax: (408) 249-7113

U.S. Southwest – Los Angeles

Phone: (805) 376-0559
Fax: (805) 376-8180

U.S. Southwest – Orange County

Phone: (949) 483-9119
Fax: (949) 483-9090

U.S. Southwest – San Diego

Phone: (858) 713-3374
Fax: (858) 713-4001

U.S. North Central – Illinois

Phone: (630) 773-3454
Fax: (630) 773-3907

U.S. South Central – Texas

Phone: (972) 733-0723
Fax: (972) 407-0639

U.S. Northeast – Massachusetts

Phone: (978) 367-3200
Fax: (978) 256-6868

U.S. Southeast – North Carolina

Phone: (919) 858-9110
Fax: (919) 858-8669

U.S. Southeast – Florida/

South America
Phone: (727) 799-8406
Fax: (727) 799-8306

U.S. Mid-Atlantic – Pennsylvania

Phone: (215) 244-6784
Fax: (215) 244-9292

Canada – Ontario

Phone: (613) 271-2358
Fax: (613) 271-2359

Europe**Europe Central – Germany**

Phone: +49 89 829-1320
Fax: +49 89 834-2734

Europe North – England

Phone: +44 1344 486444
Fax: +44 1344 486555

Europe – Israel/Greece

Phone: +972 9 9524000
Fax: +972 9 9573732

Europe South – France

Phone: +33 1 41 44 36 51
Fax: +33 1 41 44 36 90

Europe Mediterranean – Italy

Phone: +39 02 93179911
Fax: +39 02 93179913

Europe – Sweden

Phone: +46 (0) 8 5091 4319
Fax: +46 (0) 8 590 041 10

Europe – Finland

Phone: +358 (0) 9 85 666 435
Fax: +358 (0) 9 85 666 220

Asia – Pacific**Taiwan**

Phone: (886-2) 2-720-0282
Fax: (886-2) 2-757-6760

Australia

Phone: (61-2) 9869 4088
Fax: (61-2) 9869 4077

China – Central

Phone: 86-21-6361-2515
Fax: 86-21-6361-2516

China – South

Phone: (852) 2 827-0181
Fax: (852) 2 827-6488

China – South (Satellite)

Phone: (86) 755-518-2495

China – North

Phone: (86-10) 8529-9777
Fax: (86-10) 8529-9778

India

Phone: (91-11) 692-4789
Fax: (91-11) 692-4712

Korea

Phone: (82-2) 565-2880
Fax: (82-2) 565-1440

Korea (Satellite)

Phone: (82-53) 745-2880
Fax: (82-53) 745-1440

Singapore

Phone: (65) 737 7355
Fax: (65) 737 9077

Japan

Phone: (81-3) 5371 1520
Fax: (81-3) 5371 1501