

FEATURES

- Available in the Texas Instruments NanoStar™ and NanoFree™ Packages
- Control Inputs V_{IH}/V_{IL} Levels Are Referenced to V_{CCA} Voltage
- Fully Configurable Dual-Rail Design Allows Each Port to Operate Over the Full 1.2-V to 3.6-V Power-Supply Range
- I/Os Are 4.6-V Tolerant
- I_{off} Supports Partial-Power-Down Mode Operation
- Max Data Rates
 - 500 Mbps (1.8-V to 3.3-V Translation)
 - 320 Mbps (<1.8-V to 3.3-V Translation)
 - 320 Mbps (Translate to 2.5 V or 1.8 V)
 - 180 Mbps (Translate to 1.5 V)
 - 240 Mbps (Translate to 1.2 V)
- Latch-Up Performance Exceeds 100 mA Per JESD 78, Class II
- ESD Protection Exceeds JESD 22
 - 2000-V Human-Body Model (A114-A)
 - 200-V Machine Model (A115-A)
 - 1000-V Charged-Device Model (C101)

DCT OR DCU PACKAGE
(TOP VIEW)

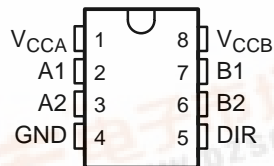

YEP OR YZP PACKAGE
(BOTTOM VIEW)

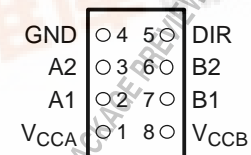

DESCRIPTION/ORDERING INFORMATION

This dual-bit noninverting bus transceiver uses two separate configurable power-supply rails. The A port is designed to track V_{CCA} . V_{CCA} accepts any supply voltage from 1.2 V to 3.6 V. The B port is designed to track V_{CCB} . V_{CCB} accepts any supply voltage from 1.2 V to 3.6 V. This allows for universal low-voltage bidirectional translation between any of the 1.2-V, 1.5-V, 1.8-V, 2.5-V, and 3.3-V voltage nodes.

The SN74AVC2T45 is designed for asynchronous communication between data buses. The device transmits data from the A bus to the B bus or from the B bus to the A bus, depending on the logic level at the direction-control (DIR) input.

The SN74AVC2T45 is designed so that the DIR input is powered by V_{CCA} .

ORDERING INFORMATION

T_A	PACKAGE ⁽¹⁾		ORDERABLE PART NUMBER	TOP-SIDE MARKING ⁽²⁾
–40°C to 85°C	NanoStar™ – WCSP (DSBGA) 0.23-mm Large Bump – YEP	Tape and reel	SN74AVC2T45YEPR	___TD__
	NanoFree™ – WCSP (DSBGA) 0.23-mm Large Bump – YZP (Pb-free)		SN74AVC2T45YZPR	
	SSOP – DCT	Tape and reel	SN74AVC2T45DCTR	DT2___
	VSSOP – DCU	Tape and reel	SN74AVC2T45DCUR	DT2_

(1) Package drawings, standard packing quantities, thermal data, symbolization, and PCB design guidelines are available at www.ti.com/sc/package.

(2) DCT: The actual top-side marking has three additional characters that designate the year, month, and assembly/test site.
DCU: The actual top-side marking has one additional character that designates the assembly/test site.

YEP/YZP: The actual top-side marking has three preceding characters to denote year, month, and sequence code, and one following character to designate the assembly/test site. Pin 1 identifier indicates solder-bump composition (1 = SnPb, · = Pb-free).

SN74AVC2T45
DUAL-BIT DUAL-SUPPLY BUS TRANSCEIVER
WITH CONFIGURABLE VOLTAGE TRANSLATION AND 3-STATE OUTPUTS

SCES531F–DECEMBER 2003–REVISED MAY 2005

DESCRIPTION/ORDERING INFORMATION (CONTINUED)

This device is fully specified for partial-power-down applications using I_{off} . The I_{off} circuitry disables the outputs, preventing damaging current backflow through the device when it is powered down.

The V_{CC} isolation feature ensures that if either V_{CC} input is at GND, both ports are in the high-impedance state.

NanoStar™ and NanoFree™ package technology is a major breakthrough in IC packaging concepts, using the die as the package.

FUNCTION TABLE
(EACH TRANSCEIVER)

INPUT		OPERATION
DIR		
L		B data to A bus
H		A data to B bus

LOGIC DIAGRAM (POSITIVE LOGIC)

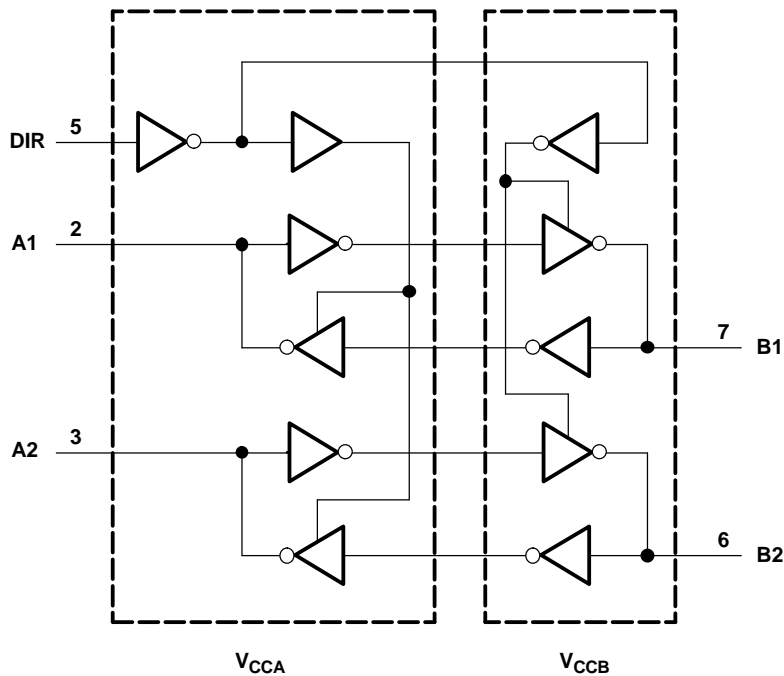

Absolute Maximum Ratings⁽¹⁾

over operating free-air temperature range (unless otherwise noted)

		MIN	MAX	UNIT	
V_{CCA} V_{CCB}	Supply voltage range	-0.5	4.6	V	
V_I	Input voltage range ⁽²⁾	I/O ports (A port)	-0.5	4.6	V
		I/O ports (B port)	-0.5	4.6	
		Control inputs	-0.5	4.6	
V_O	Voltage range applied to any output in the high-impedance or power-off state ⁽²⁾	A port	-0.5	4.6	V
		B port	-0.5	4.6	
V_O	Voltage range applied to any output in the high or low state ⁽²⁾⁽³⁾	A port	-0.5	$V_{CCA} + 0.5$	V
		B port	-0.5	$V_{CCB} + 0.5$	
I_{IK}	Input clamp current		-50	mA	
I_{OK}	Output clamp current		-50	mA	
I_O	Continuous output current		±50	mA	
	Continuous current through V_{CCA} , V_{CCB} , or GND		±100	mA	
θ_{JA}	Package thermal impedance ⁽⁴⁾	DCT package		220	°C/W
		DCU package		227	
		YEP/YZP package		102	
T_{stg}	Storage temperature range	-65	150	°C	

- (1) Stresses beyond those listed under "absolute maximum ratings" may cause permanent damage to the device. These are stress ratings only, and functional operation of the device at these or any other conditions beyond those indicated under "recommended operating conditions" is not implied. Exposure to absolute-maximum-rated conditions for extended periods may affect device reliability.
- (2) The input negative-voltage and output voltage ratings may be exceeded if the input and output current ratings are observed.
- (3) The output positive-voltage rating may be exceeded up to 4.6 V maximum if the output current ratings are observed.
- (4) The package thermal impedance is calculated in accordance with JESD 51-7.

SN74AVC2T45

DUAL-BIT DUAL-SUPPLY BUS TRANSCEIVER

WITH CONFIGURABLE VOLTAGE TRANSLATION AND 3-STATE OUTPUTS



SCES531F–DECEMBER 2003–REVISED MAY 2005

Recommended Operating Conditions⁽¹⁾⁽²⁾⁽³⁾⁽⁴⁾⁽⁵⁾

		V_{CCI}	V_{CCO}	MIN	MAX	UNIT
V_{CCA}	Supply voltage			1.2	3.6	V
V_{CCB}	Supply voltage			1.2	3.6	V
V_{IH}	High-level input voltage	Data inputs ⁽⁴⁾	1.2 V to 1.95 V	$V_{CCI} \times 0.65$		V
			1.95 V to 2.7 V	1.6		
			2.7 V to 3.6 V	2		
V_{IL}	Low-level input voltage	Data inputs ⁽⁴⁾	1.2 V to 1.95 V	$V_{CCI} \times 0.35$		V
			1.95 V to 2.7 V	0.7		
			2.7 V to 3.6 V	0.8		
V_{IH}	High-level input voltage	DIR (referenced to V_{CCA}) ⁽⁵⁾	1.2 V to 1.95 V	$V_{CCA} \times 0.65$		V
			1.95 V to 2.7 V	1.6		
			2.7 V to 3.6 V	2		
V_{IL}	Low-level input voltage	DIR (referenced to V_{CCA}) ⁽⁵⁾	1.2 V to 1.95 V	$V_{CCA} \times 0.35$		V
			1.95 V to 2.7 V	0.7		
			2.7 V to 3.6 V	0.8		
V_I	Input voltage			0	3.6	V
V_O	Output voltage	Active state		0	V_{CCO}	V
		3-state		0	3.6	
I_{OH}	High-level output current		1.2 V	-3		mA
			1.4 V to 1.6 V	-6		
			1.65 V to 1.95 V	-8		
			2.3 V to 2.7 V	-9		
			3 V to 3.6 V	-12		
I_{OL}	Low-level output current		1.2 V	3		mA
			1.4 V to 1.6 V	6		
			1.65 V to 1.95 V	8		
			2.3 V to 2.7 V	9		
			3 V to 3.6 V	12		
$\Delta t/\Delta v$	Input transition rise or fall rate				5	ns/V
T_A	Operating free-air temperature			-40	85	°C

(1) V_{CCI} is the V_{CC} associated with the data input port.

(2) V_{CCO} is the V_{CC} associated with the output port.

(3) All unused data inputs of the device must be held at V_{CCI} or GND to ensure proper device operation. Refer to the TI application report, *Implications of Slow or Floating CMOS Inputs*, literature number SCBA004.

(4) For V_{CCI} values not specified in the data sheet, $V_{IH(min)} = V_{CCI} \times 0.7$ V, $V_{IL(max)} = V_{CCI} \times 0.3$ V.

(5) For V_{CCI} values not specified in the data sheet, $V_{IH(min)} = V_{CCA} \times 0.7$ V, $V_{IL(max)} = V_{CCA} \times 0.3$ V.

Electrical Characteristics⁽¹⁾⁽²⁾

over recommended operating free-air temperature range (unless otherwise noted)

PARAMETER	TEST CONDITIONS		V _{CCA}	V _{CCB}	T _A = 25°C			-40°C to 85°C		UNIT
					MIN	TYP	MAX	MIN	MAX	
V _{OH}		V _I = V _{IH}	1.2 V to 3.6 V	1.2 V to 3.6 V				V _{CCO} - 0.2 V		V
			1.2 V	1.2 V	0.95					
			1.4 V	1.4 V				1.05		
			1.65 V	1.65 V				1.2		
			2.3 V	2.3 V				1.75		
			3 V	3 V				2.3		
V _{OL}		V _I = V _{IL}	1.2 V to 3.6 V	1.2 V to 3.6 V				0.2		V
			1.2 V	1.2 V	0.25					
			1.4 V	1.4 V				0.35		
			1.65 V	1.65 V				0.45		
			2.3 V	2.3 V				0.55		
			3 V	3 V				0.7		
I _I	DIR input	V _I = V _{CCA} or GND	1.2 V to 3.6 V	1.2 V to 3.6 V		±0.025	±0.25		±1	μA
I _{off}	A port	V _I or V _O = 0 to 3.6 V	0 V	0 to 3.6 V		±0.1	±1		±5	μA
	B port		0 to 3.6 V	0 V		±0.1	±1		±5	
I _{OZ}	A or B ports	V _O = V _{CCO} or GND	1.2 V to 3.6 V	1.2 V to 3.6 V		±0.5	±2.5		±5	μA
I _{CCA}		V _I = V _{CCI} or GND, I _O = 0	1.2 V to 3.6 V	1.2 V to 3.6 V					10	μA
			0 V	3.6 V					-2	
			3.6 V	0 V					10	
I _{CCB}		V _I = V _{CCI} or GND, I _O = 0	1.2 V to 3.6 V	1.2 V to 3.6 V					10	μA
			0 V	3.6 V					10	
			3.6 V	0 V					-2	
I _{CCA} + I _{CCB}		V _I = V _{CCI} or GND, I _O = 0	1.2 V to 3.6 V	1.2 V to 3.6 V					20	μA
C _i	Control inputs	V _I = 3.3 V or GND	3.3 V	3.3 V		2.5				pF
C _{io}	A or B ports	V _O = 3.3 V or GND	3.3 V	3.3 V		6				pF

(1) V_{CCO} is the V_{CC} associated with the output port.

(2) V_{CCI} is the V_{CC} associated with the input port.

SN74AVC2T45

DUAL-BIT DUAL-SUPPLY BUS TRANSCEIVER

WITH CONFIGURABLE VOLTAGE TRANSLATION AND 3-STATE OUTPUTS



SCES531F–DECEMBER 2003–REVISED MAY 2005

Switching Characteristics

over recommended operating free-air temperature range, $V_{CCA} = 1.2\text{ V}$ (see [Figure 11](#))

PARAMETER	FROM (INPUT)	TO (OUTPUT)	$V_{CCB} = 1.2\text{ V}$	$V_{CCB} = 1.5\text{ V}$	$V_{CCB} = 1.8\text{ V}$	$V_{CCB} = 2.5\text{ V}$	$V_{CCB} = 3.3\text{ V}$	UNIT
			TYP	TYP	TYP	TYP	TYP	
t_{PLH}	A	B	3.1	2.6	2.4	2.2	2.2	ns
t_{PHL}			3.1	2.6	2.4	2.2	2.2	
t_{PLH}	B	A	3.4	3.1	3	2.9	2.9	ns
t_{PHL}			3.4	3.1	3	2.9	2.9	
t_{PHZ}	DIR	A	5.2	5.2	5.1	5	4.8	ns
t_{PLZ}			5.2	5.2	5.1	5	4.8	
t_{PHZ}	DIR	B	5	4	3.8	2.8	3.2	ns
t_{PLZ}			5	4	3.8	2.8	3.2	
$t_{PZH}^{(1)}$	DIR	A	8.4	7.1	6.8	5.7	6.1	ns
$t_{PZL}^{(1)}$			8.4	7.1	6.8	5.7	6.1	
$t_{PZH}^{(1)}$	DIR	B	8.3	7.8	7.5	7.2	7	ns
$t_{PZL}^{(1)}$			8.3	7.8	7.5	7.2	7	

(1) The enable time is a calculated value, derived using the formula shown in the *enable times* section.

Switching Characteristics

over recommended operating free-air temperature range, $V_{CCA} = 1.5\text{ V} \pm 0.1\text{ V}$ (see [Figure 11](#))

PARAMETER	FROM (INPUT)	TO (OUTPUT)	$V_{CCB} = 1.2\text{ V}$	$V_{CCB} = 1.5\text{ V} \pm 0.1\text{ V}$		$V_{CCB} = 1.8\text{ V} \pm 0.15\text{ V}$		$V_{CCB} = 2.5\text{ V} \pm 0.2\text{ V}$		$V_{CCB} = 3.3\text{ V} \pm 0.3\text{ V}$		UNIT
			TYP	MIN	MAX	MIN	MAX	MIN	MAX	MIN	MAX	
t_{PLH}	A	B	2.8	0.7	5.4	0.5	4.6	0.4	3.7	0.3	3.5	ns
t_{PHL}			2.8	0.7	5.4	0.5	4.6	0.4	3.7	0.3	3.5	
t_{PLH}	B	A	2.7	0.8	5.4	0.7	5.2	0.6	4.9	0.5	4.7	ns
t_{PHL}			2.7	0.8	5.4	0.7	5.2	0.6	4.9	0.5	4.7	
t_{PHZ}	DIR	A	3.9	1.3	8.5	1.3	7.8	1.1	7.7	1.4	7.6	ns
t_{PLZ}			3.9	1.3	8.5	1.3	7.8	1.1	7.7	1.4	7.6	
t_{PHZ}	DIR	B	4.7	1.1	7	1.4	6.9	1.2	6.9	1.7	7.1	ns
t_{PLZ}			4.7	1.1	7	1.4	6.9	1.2	6.9	1.7	7.1	
$t_{PZH}^{(1)}$	DIR	A	7.4		12.4		12.1		11.8		11.8	ns
$t_{PZL}^{(1)}$			7.4		12.4		12.1		11.8		11.8	
$t_{PZH}^{(1)}$	DIR	B	6.7		13.9		11.6		9.1		7.8	ns
$t_{PZL}^{(1)}$			6.7		13.9		11.6		9.1		7.8	

(1) The enable time is a calculated value, derived using the formula shown in the *enable times* section.

Switching Characteristics

over recommended operating free-air temperature range, $V_{CCA} = 1.8\text{ V} \pm 0.15\text{ V}$ (see [Figure 11](#))

PARAMETER	FROM (INPUT)	TO (OUTPUT)	$V_{CCB} = 1.2\text{ V}$	$V_{CCB} = 1.5\text{ V} \pm 0.1\text{ V}$		$V_{CCB} = 1.8\text{ V} \pm 0.15\text{ V}$		$V_{CCB} = 2.5\text{ V} \pm 0.2\text{ V}$		$V_{CCB} = 3.3\text{ V} \pm 0.3\text{ V}$		UNIT
			TYP	MIN	MAX	MIN	MAX	MIN	MAX	MIN	MAX	
t_{PLH}	A	B	2.7	0.5	5.2	0.4	4.3	0.2	3.4	0.2	3.1	ns
t_{PHL}			2.7	0.5	5.2	0.4	4.3	0.2	3.4	0.2	3.1	
t_{PLH}	B	A	2.4	0.7	4.7	0.5	4.4	0.5	4	0.4	3.8	ns
t_{PHL}			2.4	0.7	4.7	0.5	4.4	0.5	4	0.4	3.8	
t_{PHZ}	DIR	A	3.7	1.3	8.1	0.7	6.9	1.4	5.3	1.1	4.5	ns
t_{PLZ}			3.7	1.3	8.1	0.7	6.9	1.4	5.3	1.1	4.5	
t_{PHZ}	DIR	B	4.4	1.3	5.8	1.3	5.9	0.8	5.7	1.5	5.9	ns
t_{PLZ}			4.4	1.3	5.8	1.3	5.9	0.8	5.7	1.5	5.9	
$t_{PZH}^{(1)}$	DIR	A	6.8	10.4		10.3		9.7		9.7		ns
$t_{PZL}^{(1)}$			6.8	10.4		10.3		9.7		9.7		
$t_{PZH}^{(1)}$	DIR	B	6.4	13.3		11.2		8.6		7.4		ns
$t_{PZL}^{(1)}$			6.4	13.3		11.2		8.6		7.4		

(1) The enable time is a calculated value, derived using the formula shown in the *enable times* section.

Switching Characteristics

over recommended operating free-air temperature range, $V_{CCA} = 2.5\text{ V} \pm 0.2\text{ V}$ (see [Figure 11](#))

PARAMETER	FROM (INPUT)	TO (OUTPUT)	$V_{CCB} = 1.2\text{ V}$	$V_{CCB} = 1.5\text{ V} \pm 0.1\text{ V}$		$V_{CCB} = 1.8\text{ V} \pm 0.15\text{ V}$		$V_{CCB} = 2.5\text{ V} \pm 0.2\text{ V}$		$V_{CCB} = 3.3\text{ V} \pm 0.3\text{ V}$		UNIT
			TYP	MIN	MAX	MIN	MAX	MIN	MAX	MIN	MAX	
t_{PLH}	A	B	2.6	0.4	4.9	0.2	4	0.2	3	0.2	2.6	ns
t_{PHL}			2.6	0.4	4.9	0.2	4	0.2	3	0.2	2.6	
t_{PLH}	B	A	2.1	0.6	3.8	0.5	3.4	0.4	3	0.3	2.8	ns
t_{PHL}			2.1	0.6	3.8	0.5	3.4	0.4	3	0.3	2.8	
t_{PHZ}	DIR	A	2.4	0.7	7.9	0.8	6.4	0.8	5	0.5	4.3	ns
t_{PLZ}			2.4	0.7	7.9	0.8	6.4	0.8	5	0.5	4.3	
t_{PHZ}	DIR	B	3.8	1	4.3	0.6	4.3	0.5	4.2	1.1	4.1	ns
t_{PLZ}			3.8	1	4.3	0.6	4.3	0.5	4.2	1.1	4.1	
$t_{PZH}^{(1)}$	DIR	A	5.9	7.9		7.7		7.2		6.9		ns
$t_{PZL}^{(1)}$			5.9	7.9		7.7		7.2		6.9		
$t_{PZH}^{(1)}$	DIR	B	5	12.8		10.4		7.9		6.8		ns
$t_{PZL}^{(1)}$			5	12.8		10.4		7.9		6.8		

(1) The enable time is a calculated value, derived using the formula shown in the *enable times* section.

SN74AVC2T45

DUAL-BIT DUAL-SUPPLY BUS TRANSCEIVER

WITH CONFIGURABLE VOLTAGE TRANSLATION AND 3-STATE OUTPUTS



SCES531F–DECEMBER 2003–REVISED MAY 2005

Switching Characteristics

over recommended operating free-air temperature range, $V_{CCA} = 3.3 \text{ V} \pm 0.3 \text{ V}$ (see Figure 11)

PARAMETER	FROM (INPUT)	TO (OUTPUT)	$V_{CCB} = 1.2 \text{ V}$	$V_{CCB} = 1.5 \text{ V} \pm 0.1 \text{ V}$		$V_{CCB} = 1.8 \text{ V} \pm 0.15 \text{ V}$		$V_{CCB} = 2.5 \text{ V} \pm 0.2 \text{ V}$		$V_{CCB} = 3.3 \text{ V} \pm 0.3 \text{ V}$		UNIT
			TYP	MIN	MAX	MIN	MAX	MIN	MAX	MIN	MAX	
t_{PLH}	A	B	2.5	0.3	4.7	0.2	3.8	0.2	2.8	0.2	2.4	ns
t_{PHL}			2.5	0.3	4.7	0.2	3.8	0.2	2.8	0.2	2.4	
t_{PLH}	B	A	2.1	0.6	3.6	0.4	3.1	0.3	2.6	0.3	2.4	ns
t_{PHL}			2.1	0.6	3.6	0.4	3.1	0.3	2.6	0.3	2.4	
t_{PHZ}	DIR	A	2.9	1.1	8	1	6.5	1.3	4.7	1.2	4	ns
t_{PLZ}			2.9	1.1	8	1	6.5	1.3	4.7	1.2	4	
t_{PHZ}	DIR	B	3.4	0.5	6.6	0.3	5.6	0.3	4.6	1.1	3.5	ns
t_{PLZ}			3.4	0.5	6.6	0.3	5.6	0.3	4.6	1.1	3.5	
$t_{PZH}^{(1)}$	DIR	A	5.5	6.9		6.6		6.2		5.9		ns
$t_{PZL}^{(1)}$			5.5	6.9		6.6		6.2		5.9		
$t_{PZH}^{(1)}$	DIR	B	5.4	12.7		10.3		7.4		6.3		ns
$t_{PZL}^{(1)}$			5.4	12.7		10.3		7.4		6.3		

(1) The enable time is a calculated value, derived using the formula shown in the *enable times* section.

Operating Characteristics

$T_A = 25^\circ\text{C}$

PARAMETER		TEST CONDITIONS	$V_{CCA} = V_{CCB} = 1.2 \text{ V}$	$V_{CCA} = V_{CCB} = 1.5 \text{ V}$	$V_{CCA} = V_{CCB} = 1.8 \text{ V}$	$V_{CCA} = V_{CCB} = 2.5 \text{ V}$	$V_{CCA} = V_{CCB} = 3.3 \text{ V}$	UNIT
			TYP	TYP	TYP	TYP	TYP	
$C_{pdA}^{(1)}$	A-port input, B-port output	$C_L = 0$, $f = 10 \text{ MHz}$, $t_r = t_f = 1 \text{ ns}$	3	3	3	3	4	pF
	B-port input, A-port output		12	13	13	14	15	
$C_{pdB}^{(1)}$	A-port input, B-port output	$C_L = 0$, $f = 10 \text{ MHz}$, $t_r = t_f = 1 \text{ ns}$	12	13	13	14	15	pF
	B-port input, A-port output		3	3	3	3	4	

(1) Power-dissipation capacitance per transceiver

Power-Up Considerations

A proper power-up sequence always should be followed to avoid excessive supply current, bus contention, oscillations, or other anomalies. To guard against such power-up problems, take the following precautions:

1. Connect ground before any supply voltage is applied.
2. Power up V_{CCA} .
3. V_{CCB} can be ramped up along with or after V_{CCA} .

Table 1. Typical Total Static Power Consumption ($I_{CCA} + I_{CCB}$)

V_{CCB}	V_{CCA}						UNIT
	0 V	1.2 V	1.5 V	1.8 V	2.5 V	3.3 V	
0 V	0	<0.5	<0.5	<0.5	<0.5	<0.5	μA
1.2 V	<0.5	<1	<1	<1	<1	1	
1.5 V	<0.5	<1	<1	<1	<1	1	
1.8 V	<0.5	<1	<1	<1	<1	<1	
2.5 V	<0.5	1	<1	<1	<1	<1	
3.3 V	<0.5	1	<1	<1	<1	<1	

SN74AVC2T45
DUAL-BIT DUAL-SUPPLY BUS TRANSCEIVER
WITH CONFIGURABLE VOLTAGE TRANSLATION AND 3-STATE OUTPUTS

SCES531F—DECEMBER 2003—REVISED MAY 2005



TYPICAL CHARACTERISTICS

TYPICAL PROPAGATION DELAY (A to B) vs LOAD CAPACITANCE, $T_A = 25^\circ\text{C}$, $V_{CCA} = 1.2\text{ V}$

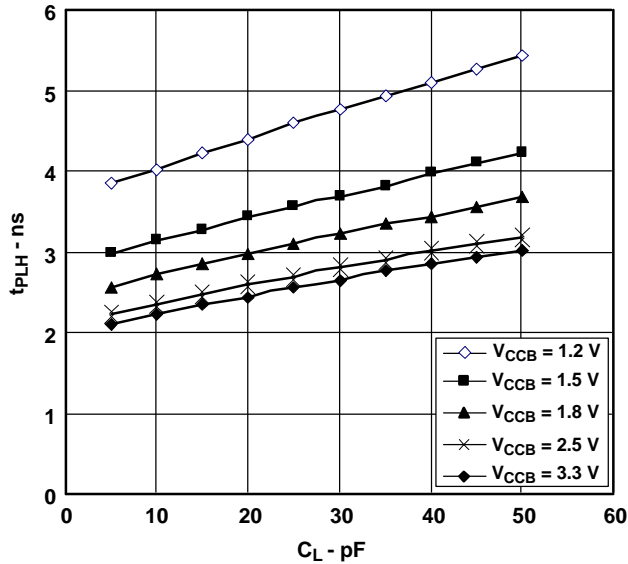

Figure 1.

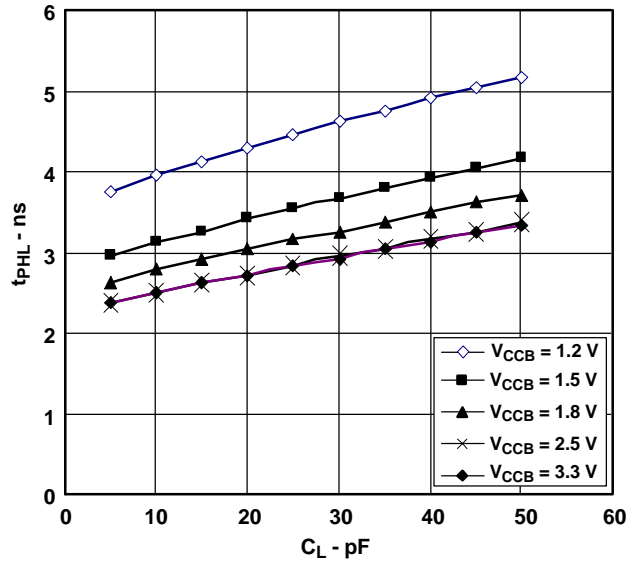

Figure 2.

TYPICAL PROPAGATION DELAY (A to B) vs LOAD CAPACITANCE, $T_A = 25^\circ\text{C}$, $V_{CCA} = 1.5\text{ V}$

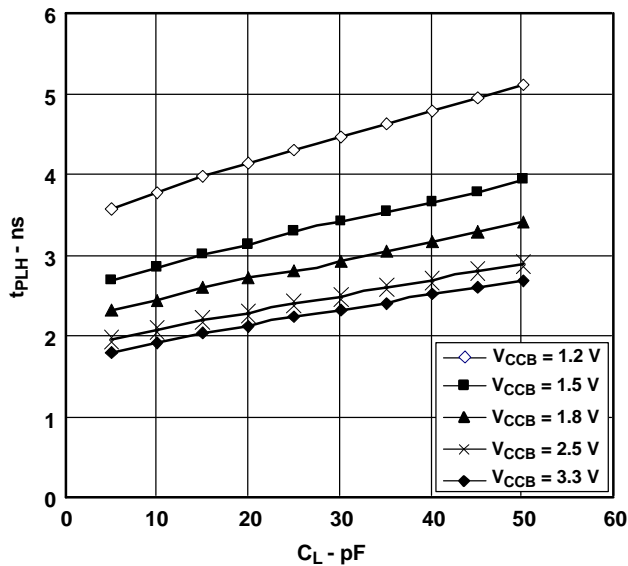

Figure 3.

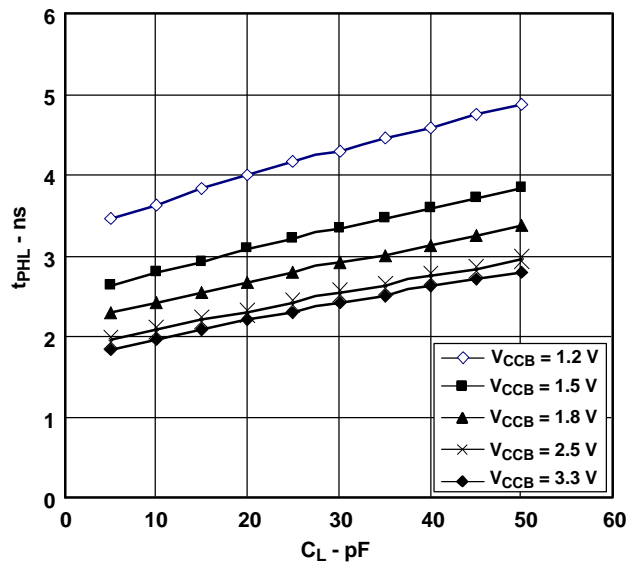

Figure 4.

TYPICAL CHARACTERISTICS

TYPICAL PROPAGATION DELAY (A to B) vs LOAD CAPACITANCE, $T_A = 25^\circ\text{C}$, $V_{CCA} = 1.8\text{ V}$

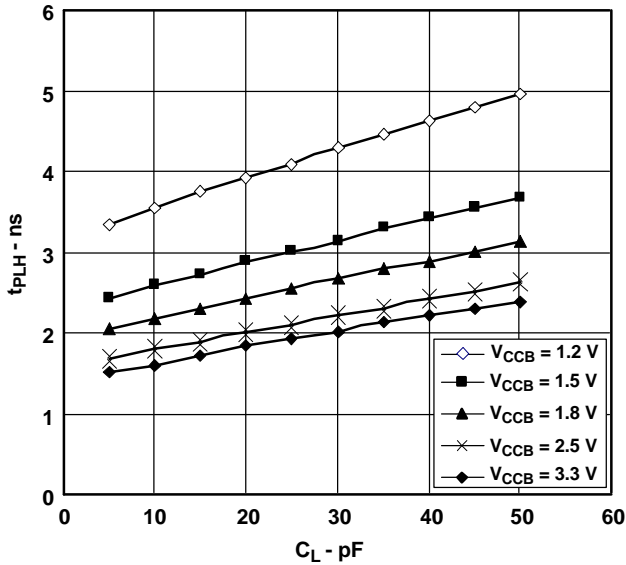

Figure 5.

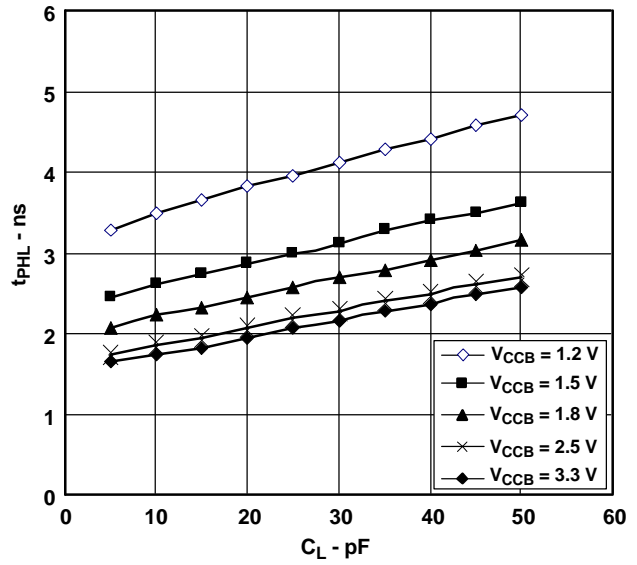

Figure 6.

TYPICAL PROPAGATION DELAY (A to B) vs LOAD CAPACITANCE, $T_A = 25^\circ\text{C}$, $V_{CCA} = 2.5\text{ V}$

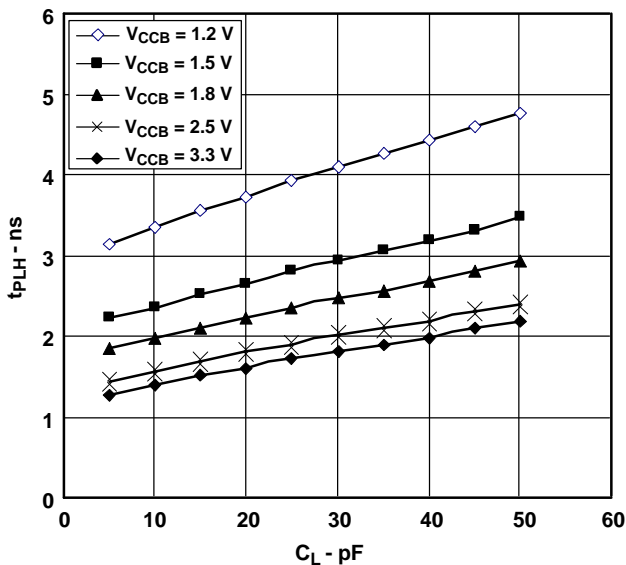

Figure 7.

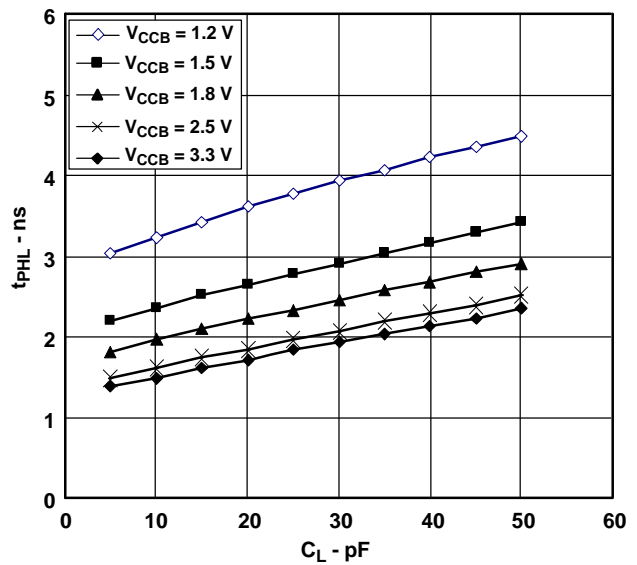

Figure 8.

SN74AVC2T45
DUAL-BIT DUAL-SUPPLY BUS TRANSCEIVER
WITH CONFIGURABLE VOLTAGE TRANSLATION AND 3-STATE OUTPUTS

SCES531F—DECEMBER 2003—REVISED MAY 2005



TYPICAL CHARACTERISTICS

TYPICAL PROPAGATION DELAY (A to B) vs LOAD CAPACITANCE, $T_A = 25^\circ\text{C}$, $V_{CCA} = 3.3\text{ V}$

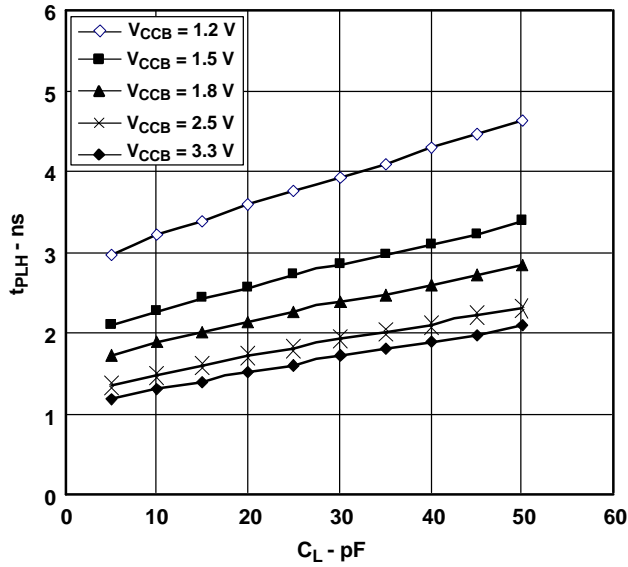

Figure 9.

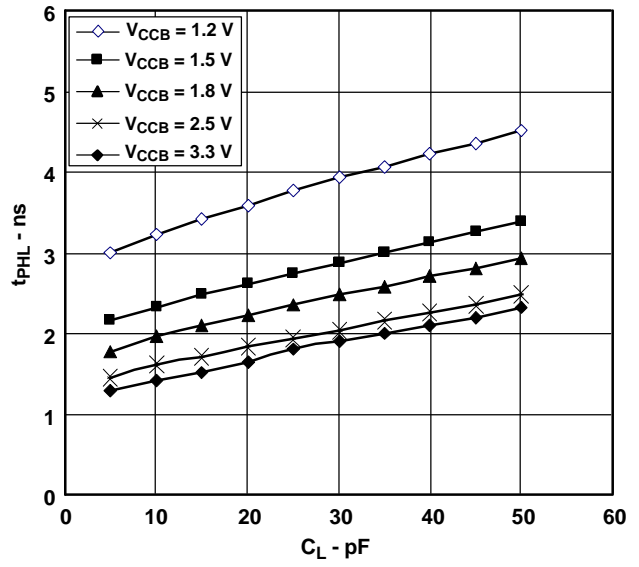
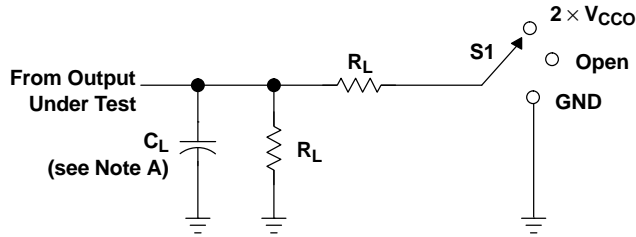

Figure 10.

PARAMETER MEASUREMENT INFORMATION



LOAD CIRCUIT

TEST	S1
t_{pd}	Open
t_{PLZ}/t_{PZL}	$2 \times V_{CCO}$
t_{PHZ}/t_{PZH}	GND

V_{CCO}	C_L	R_L	V_{TP}
1.2 V	15 pF	2 k Ω	0.1 V
1.5 V \pm 0.1 V	15 pF	2 k Ω	0.1 V
1.8 V \pm 0.15 V	15 pF	2 k Ω	0.15 V
2.5 V \pm 0.2 V	15 pF	2 k Ω	0.15 V
3.3 V \pm 0.3 V	15 pF	2 k Ω	0.3 V

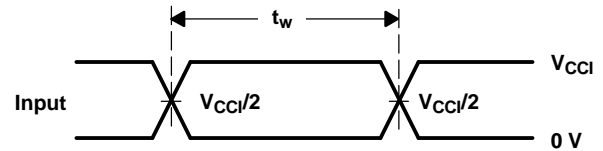

VOLTAGE WAVEFORMS
PULSE DURATION

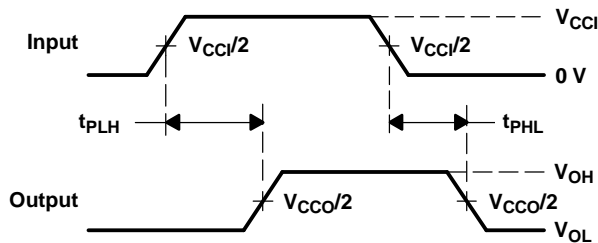

VOLTAGE WAVEFORMS
PROPAGATION DELAY TIMES

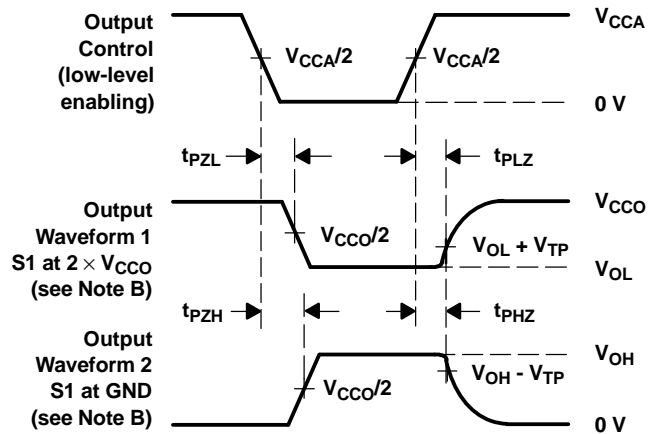

VOLTAGE WAVEFORMS
ENABLE AND DISABLE TIMES

- NOTES: A. C_L includes probe and jig capacitance.
 B. Waveform 1 is for an output with internal conditions such that the output is low, except when disabled by the output control. Waveform 2 is for an output with internal conditions such that the output is high, except when disabled by the output control.
 C. All input pulses are supplied by generators having the following characteristics: $PRR \leq 10$ MHz, $Z_O = 50 \Omega$, $dv/dt \geq 1$ V/ns.
 D. The outputs are measured one at a time, with one transition per measurement.
 E. t_{PLZ} and t_{PHZ} are the same as t_{dis} .
 F. t_{PZL} and t_{PZH} are the same as t_{en} .
 G. t_{PLH} and t_{PHL} are the same as t_{pd} .
 H. V_{CC1} is the V_{CC} associated with the input port.
 I. V_{CCO} is the V_{CC} associated with the output port.

Figure 11. Load Circuit and Voltage Waveforms

SN74AVC2T45
DUAL-BIT DUAL-SUPPLY BUS TRANSCEIVER
WITH CONFIGURABLE VOLTAGE TRANSLATION AND 3-STATE OUTPUTS

SCES531F–DECEMBER 2003–REVISED MAY 2005

APPLICATION INFORMATION

Figure 12 is an example circuit of the SN74AVC2T45 used in a bidirectional logic level-shifting application.

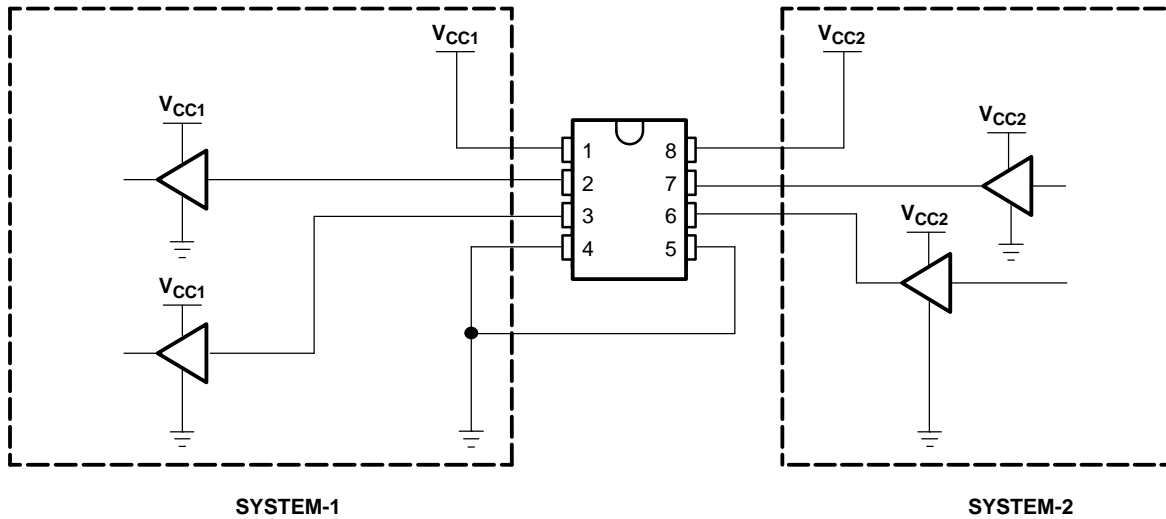

PIN	NAME	FUNCTION	DESCRIPTION
1	V _{CCA}	V _{CC1}	SYSTEM-1 supply voltage (1.2 V to 3.6 V)
2	A1	OUT1	Output level depends on V _{CC1} voltage.
3	A2	OUT2	Output level depends on V _{CC1} voltage.
4	GND	GND	Device GND
5	DIR	DIR	The GND (low-level) determines B-port to A-port direction.
6	B2	IN2	Input threshold value depends on V _{CC2} voltage.
7	B1	IN1	Input threshold value depends on V _{CC2} voltage.
8	V _{CCB}	V _{CC2}	SYSTEM-2 supply voltage (1.2 V to 3.6 V)

Figure 12. Bidirectional Logic Level-Shifting Application

APPLICATION INFORMATION

Figure 13 shows the SN74AVC2T45 used in a bidirectional logic level-shifting application. Since the SN74AVC2T45 does not have an output-enable (OE) pin, the system designer should take precautions to avoid bus contention between SYSTEM-1 and SYSTEM-2 when changing directions.

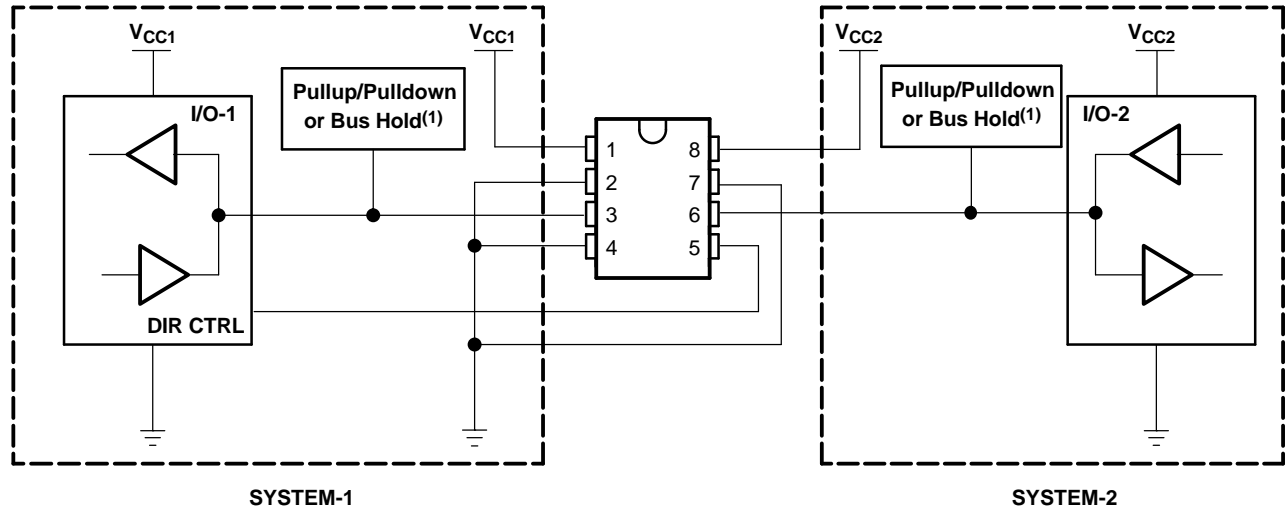

Following is a sequence that illustrates data transmission from SYSTEM-1 to SYSTEM-2 and then from SYSTEM-2 to SYSTEM-1.

STATE	DIR CTRL	I/O-1	I/O-2	DESCRIPTION
1	H	Out	In	SYSTEM-1 data to SYSTEM-2
2	H	Hi-Z	Hi-Z	SYSTEM-2 is getting ready to send data to SYSTEM-1. I/O-1 and I/O-2 are disabled. The bus-line state depends on pullup or pulldown. ⁽¹⁾
3	L	Hi-Z	Hi-Z	DIR bit is flipped. I/O-1 and I/O-2 still are disabled. The bus-line state depends on pullup or pulldown. ⁽¹⁾
4	L	Out	In	SYSTEM-2 data to SYSTEM-1

(1) SYSTEM-1 and SYSTEM-2 must use the same conditions, i.e., both pullup or both pulldown.

Figure 13. Bidirectional Logic Level-Shifting Application

Enable Times

Calculate the enable times for the SN74AVC2T45 using the following formulas:

- $t_{PZH} \text{ (DIR to A)} = t_{PLZ} \text{ (DIR to B)} + t_{PLH} \text{ (B to A)}$
- $t_{PZL} \text{ (DIR to A)} = t_{PHZ} \text{ (DIR to B)} + t_{PHL} \text{ (B to A)}$
- $t_{PZH} \text{ (DIR to B)} = t_{PLZ} \text{ (DIR to A)} + t_{PLH} \text{ (A to B)}$
- $t_{PZL} \text{ (DIR to B)} = t_{PHZ} \text{ (DIR to A)} + t_{PHL} \text{ (A to B)}$

In a bidirectional application, these enable times provide the maximum delay from the time the DIR bit is switched until an output is expected. For example, if the SN74AVC2T45 initially is transmitting from A to B, then the DIR bit is switched; the B port of the device must be disabled before presenting it with an input. After the B port has been disabled, an input signal applied to it appears on the corresponding A port after the specified propagation delay.

PACKAGING INFORMATION

Orderable Device	Status ⁽¹⁾	Package Type	Package Drawing	Pins	Package Qty	Eco Plan ⁽²⁾	Lead/Ball Finish	MSL Peak Temp ⁽³⁾
SN74AVC2T45DCTR	ACTIVE	SM8	DCT	8	3000	Pb-Free (RoHS)	CU NIPDAU	Level-1-260C-UNLIM
SN74AVC2T45DCTRE4	ACTIVE	SM8	DCT	8	3000	Pb-Free (RoHS)	CU NIPDAU	Level-1-260C-UNLIM
SN74AVC2T45DCTT	ACTIVE	SM8	DCT	8	250	Pb-Free (RoHS)	CU NIPDAU	Level-1-260C-UNLIM
SN74AVC2T45DCUR	ACTIVE	US8	DCU	8	3000	Pb-Free (RoHS)	CU NIPDAU	Level-1-260C-UNLIM
SN74AVC2T45DCURE4	ACTIVE	US8	DCU	8	3000	Pb-Free (RoHS)	CU NIPDAU	Level-1-260C-UNLIM
SN74AVC2T45DCUT	ACTIVE	US8	DCU	8	250	Pb-Free (RoHS)	CU NIPDAU	Level-1-260C-UNLIM
SN74AVC2T45DCUTE4	ACTIVE	US8	DCU	8	250	Pb-Free (RoHS)	CU NIPDAU	Level-1-260C-UNLIM
SN74AVC2T45YEPR	ACTIVE	WCSP	YEP	8	3000	TBD	SNPB	Level-1-260C-UNLIM
SN74AVC2T45YZPR	ACTIVE	WCSP	YZP	8	3000	Pb-Free (RoHS)	SNAGCU	Level-1-260C-UNLIM

⁽¹⁾ The marketing status values are defined as follows:

ACTIVE: Product device recommended for new designs.

LIFEBUY: TI has announced that the device will be discontinued, and a lifetime-buy period is in effect.

NRND: Not recommended for new designs. Device is in production to support existing customers, but TI does not recommend using this part in a new design.

PREVIEW: Device has been announced but is not in production. Samples may or may not be available.

OBSOLETE: TI has discontinued the production of the device.

⁽²⁾ Eco Plan - The planned eco-friendly classification: Pb-Free (RoHS) or Green (RoHS & no Sb/Br) - please check <http://www.ti.com/productcontent> for the latest availability information and additional product content details.

TBD: The Pb-Free/Green conversion plan has not been defined.

Pb-Free (RoHS): TI's terms "Lead-Free" or "Pb-Free" mean semiconductor products that are compatible with the current RoHS requirements for all 6 substances, including the requirement that lead not exceed 0.1% by weight in homogeneous materials. Where designed to be soldered at high temperatures, TI Pb-Free products are suitable for use in specified lead-free processes.

Green (RoHS & no Sb/Br): TI defines "Green" to mean Pb-Free (RoHS compatible), and free of Bromine (Br) and Antimony (Sb) based flame retardants (Br or Sb do not exceed 0.1% by weight in homogeneous material)

⁽³⁾ MSL, Peak Temp. -- The Moisture Sensitivity Level rating according to the JEDEC industry standard classifications, and peak solder temperature.

Important Information and Disclaimer:The information provided on this page represents TI's knowledge and belief as of the date that it is provided. TI bases its knowledge and belief on information provided by third parties, and makes no representation or warranty as to the accuracy of such information. Efforts are underway to better integrate information from third parties. TI has taken and continues to take reasonable steps to provide representative and accurate information but may not have conducted destructive testing or chemical analysis on incoming materials and chemicals. TI and TI suppliers consider certain information to be proprietary, and thus CAS numbers and other limited information may not be available for release.

In no event shall TI's liability arising out of such information exceed the total purchase price of the TI part(s) at issue in this document sold by TI to Customer on an annual basis.

MECHANICAL DATA

MPDS049B – MAY 1999 – REVISED OCTOBER 2002

DCT (R-PDSO-G8)

PLASTIC SMALL-OUTLINE PACKAGE

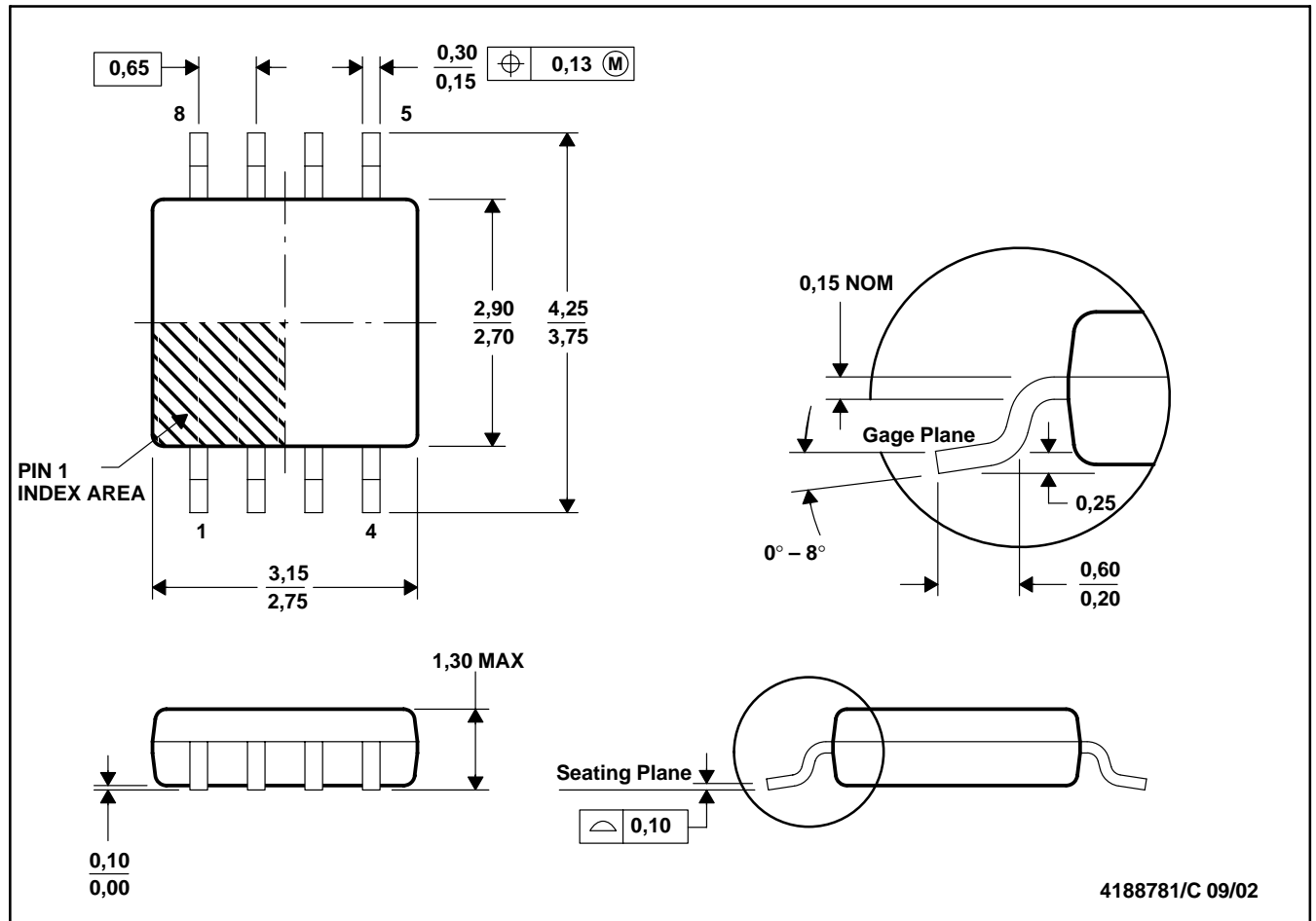

- NOTES: A. All linear dimensions are in millimeters.
 B. This drawing is subject to change without notice.
 C. Body dimensions do not include mold flash or protrusion
 D. Falls within JEDEC MO-187 variation DA.

MECHANICAL DATA

DCU (R-PDSO-G8)

PLASTIC SMALL-OUTLINE PACKAGE (DIE DOWN)

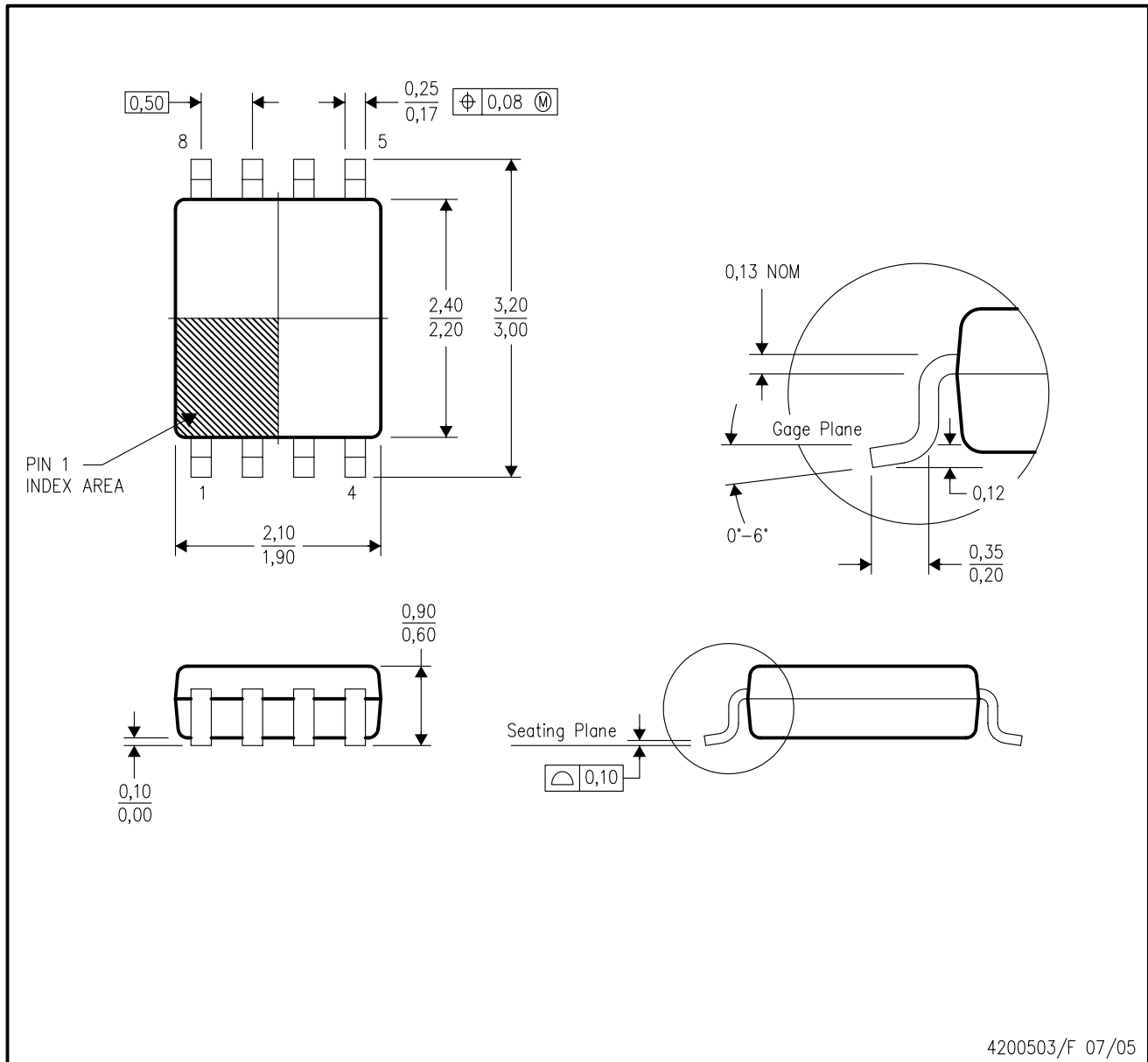

4200503/F 07/05

- NOTES:
- All linear dimensions are in millimeters.
 - This drawing is subject to change without notice.
 - Body dimensions do not include mold flash or protrusion. Mold flash and protrusion shall not exceed 0.15 per side.
 - Falls within JEDEC MO-187 variation CA.

MECHANICAL DATA

YZP (R-XBGA-N8)

DIE-SIZE BALL GRID ARRAY

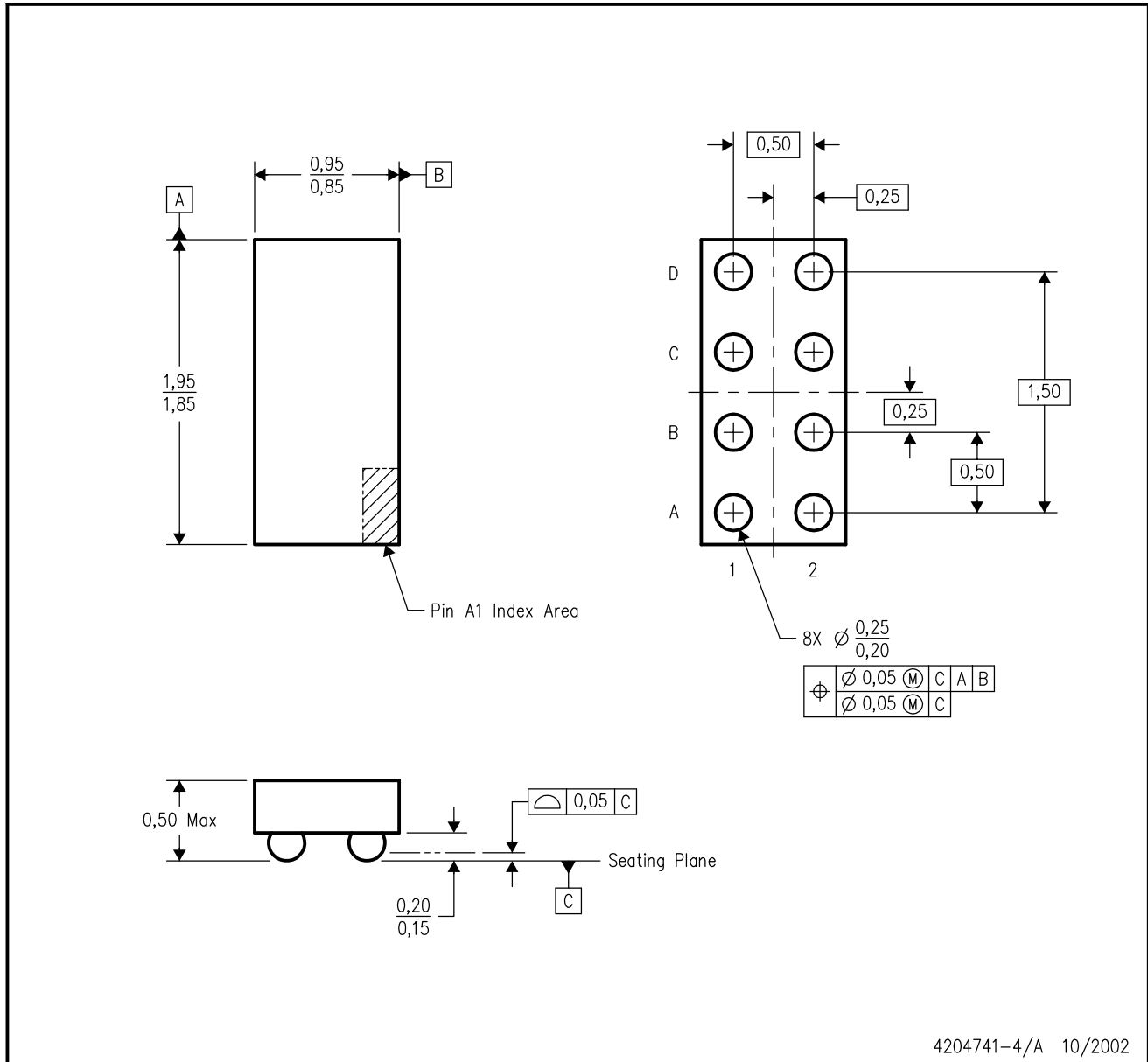

- NOTES:
- A. All linear dimensions are in millimeters.
 - B. This drawing is subject to change without notice.
 - C. NanoFree™ package configuration.
 - D. This package is lead-free. Refer to the 8 YEP package (drawing 4204725) for tin-lead (SnPb).

MECHANICAL DATA

YEP (R-XBGA-N8)

DIE-SIZE BALL GRID ARRAY

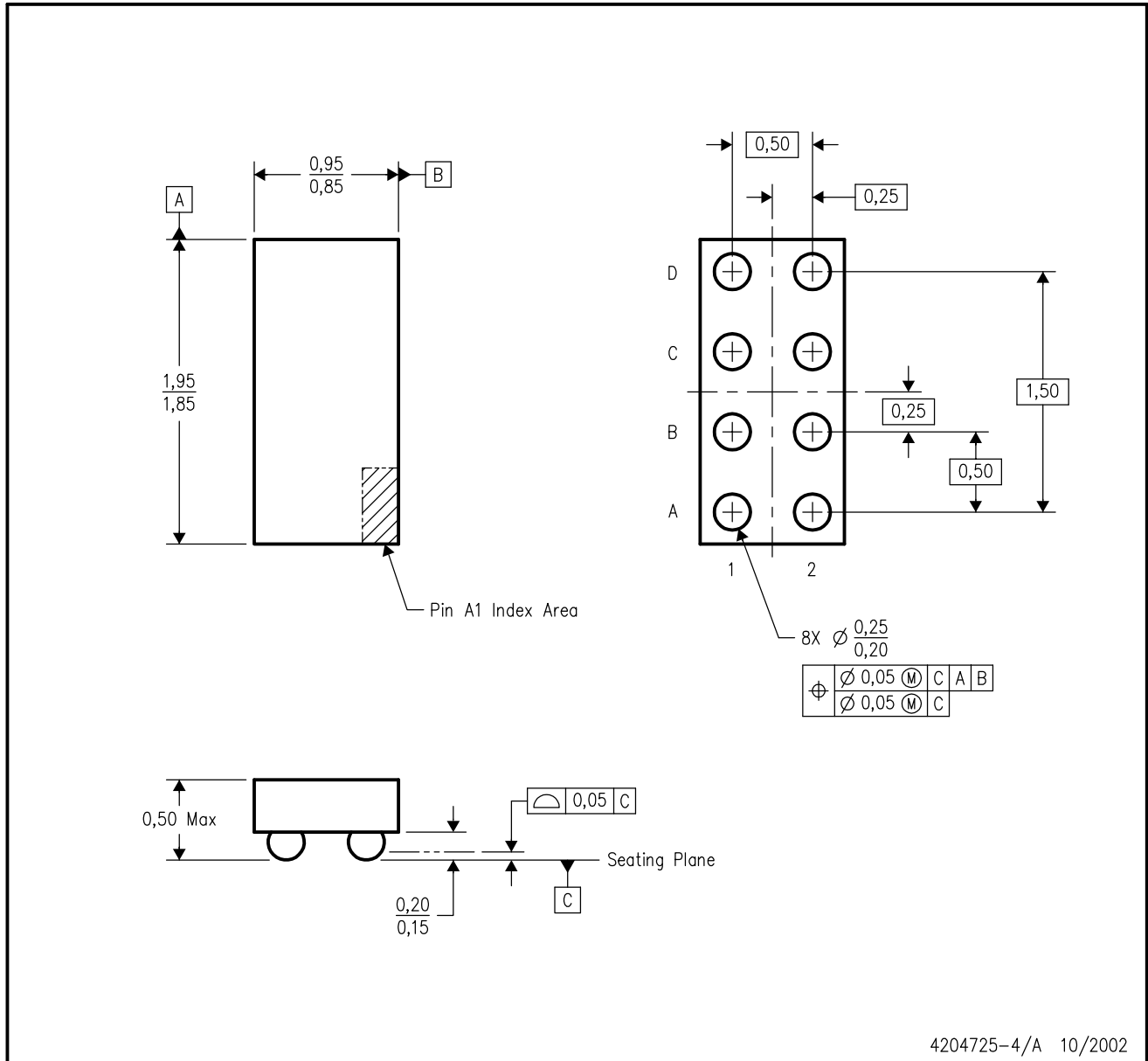

4204725-4/A 10/2002

- NOTES:
- A. All linear dimensions are in millimeters.
 - B. This drawing is subject to change without notice.
 - C. NanoStar™ package configuration.
 - D. This package is tin-lead (SnPb). Refer to the 8 YZP package (drawing 4204741) for lead-free.

NanoStar is a trademark of Texas Instruments.

IMPORTANT NOTICE

Texas Instruments Incorporated and its subsidiaries (TI) reserve the right to make corrections, modifications, enhancements, improvements, and other changes to its products and services at any time and to discontinue any product or service without notice. Customers should obtain the latest relevant information before placing orders and should verify that such information is current and complete. All products are sold subject to TI's terms and conditions of sale supplied at the time of order acknowledgment.

TI warrants performance of its hardware products to the specifications applicable at the time of sale in accordance with TI's standard warranty. Testing and other quality control techniques are used to the extent TI deems necessary to support this warranty. Except where mandated by government requirements, testing of all parameters of each product is not necessarily performed.

TI assumes no liability for applications assistance or customer product design. Customers are responsible for their products and applications using TI components. To minimize the risks associated with customer products and applications, customers should provide adequate design and operating safeguards.

TI does not warrant or represent that any license, either express or implied, is granted under any TI patent right, copyright, mask work right, or other TI intellectual property right relating to any combination, machine, or process in which TI products or services are used. Information published by TI regarding third-party products or services does not constitute a license from TI to use such products or services or a warranty or endorsement thereof. Use of such information may require a license from a third party under the patents or other intellectual property of the third party, or a license from TI under the patents or other intellectual property of TI.

Reproduction of information in TI data books or data sheets is permissible only if reproduction is without alteration and is accompanied by all associated warranties, conditions, limitations, and notices. Reproduction of this information with alteration is an unfair and deceptive business practice. TI is not responsible or liable for such altered documentation.

Resale of TI products or services with statements different from or beyond the parameters stated by TI for that product or service voids all express and any implied warranties for the associated TI product or service and is an unfair and deceptive business practice. TI is not responsible or liable for any such statements.

Following are URLs where you can obtain information on other Texas Instruments products and application solutions:

Products		Applications	
Amplifiers	amplifier.ti.com	Audio	www.ti.com/audio
Data Converters	dataconverter.ti.com	Automotive	www.ti.com/automotive
DSP	dsp.ti.com	Broadband	www.ti.com/broadband
Interface	interface.ti.com	Digital Control	www.ti.com/digitalcontrol
Logic	logic.ti.com	Military	www.ti.com/military
Power Mgmt	power.ti.com	Optical Networking	www.ti.com/opticalnetwork
Microcontrollers	microcontroller.ti.com	Security	www.ti.com/security
		Telephony	www.ti.com/telephony
		Video & Imaging	www.ti.com/video
		Wireless	www.ti.com/wireless

Mailing Address: Texas Instruments
Post Office Box 655303 Dallas, Texas 75265