



M-I-X-E-D S-I-G-N-A-L S-O-L-U-T-I-O-N-S

CMX615

Digital Line to POTS Interface

D/615/4 December 1999

Provisional Issue

Features

- Pre-Programmed Tone Generators
- Fully Integrated DTMF Encoder
- SPM Generator
- Simple Serial Control Interface
- 'Zero-Power' (1 μ A) Standby Mode
- 3.58MHz Xtal/Clock
- V23/Bell 202 FSK Generator
- Digital Ringing Voltage Generator

Applications

- Digital Line to POTS Interface
- Subscriber Terminal Adapters
- Wireless Local Loop
- Computer Telephony Integration
- Telephone/Radio Patch Systems
- Pair Gain Systems
- Billing/SPM Systems

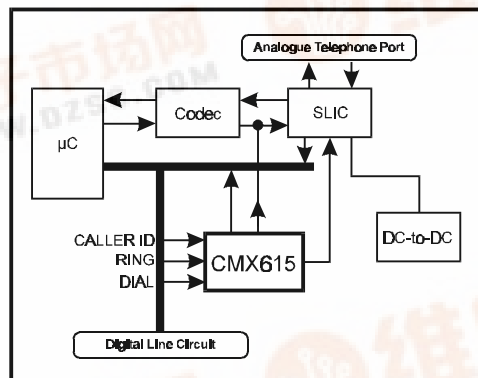

1.1 Brief Description

The CMX615 is an integrated telecom tone generator and DTMF encoder designed for ISDN interfaces, Wireless Local Loop and Analogue to Digital Phone Conversion systems. The tone generator covers an extensive range of pre-programmed tones used in analogue phone systems (POTS). Three outputs are provided: 'Ringing signals', 'In-band tones or FSK data', and '12kHz/16kHz Metering pulses'. Simple software control facilitates the interface to a wide range of commonly used μ Cs and SLICs, enabling a comprehensive analogue telephone line presentation.

The DTMF encoder generates the appropriate DTMF tones for the POTS interface. DTMF tone pairs can be encoded along with each tone singly or with other dual tone signals, such as those used in CIDCW systems and 'On Hook' signalling systems.

Other tone standards supported are: Fax and Modem 'answer' and 'originate', ITU (CCITT) 'R1' and 'R2' signals, and sufficient tones for simple melody generation. Communication to and from the host μ Controller is performed by a 'C-BUS' serial interface, which is compatible with the 'SPI' interface.

CONTENTS

<u>Section</u>		<u>Page</u>
1.1 Brief Description.....		1
1.2 Block Diagram		3
1.3 Signal List.....		4
1.4 External Components.....		6
1.5 General Description.....		7
1.5.1 Xtal Osc and Clock Dividers		7
1.5.2 Uncommitted Amplifier		7
1.5.3 Tone/FSK Encoder and Tone Encoder		7
1.5.4 SPM Generator		10
1.5.5 Transmit Operator		10
1.5.6 Tx UART.....		10
1.5.7 'C-BUS' Interface.....		11
1.5.8 'C-BUS' Registers.....		13
1.6 Application Notes.....		14
1.6.1 'Telecom Tones		14
1.6.2 'C-BUS Timing.....		17
1.7 Performance Specification.....		21
1.7.1 Electrical Performance.....		21
1.7.2 Packaging.....		25

1.2 Block Diagram

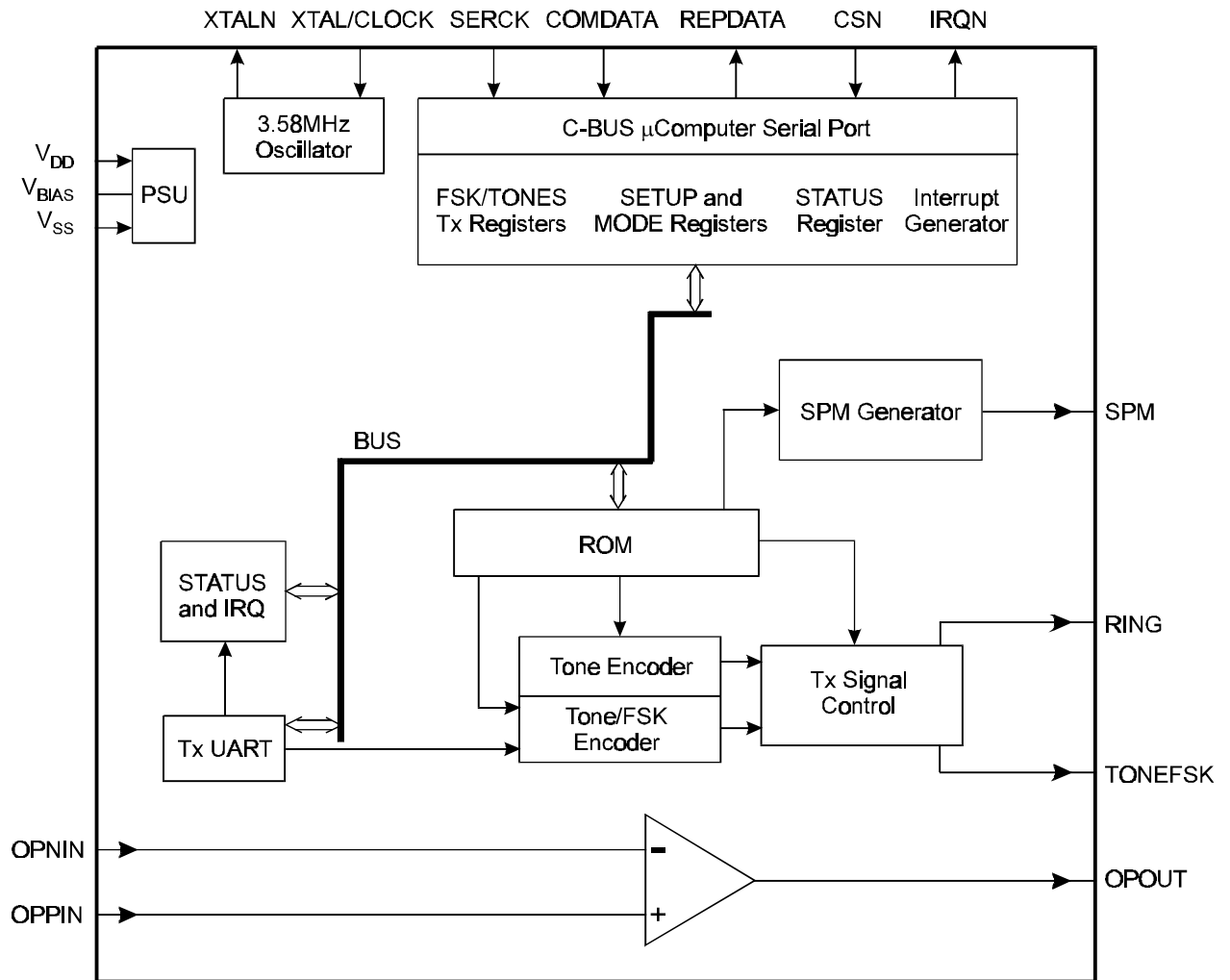

Figure 1 Block Diagram

1.3 Signal List

CMX615 D4/P3	Signal		Description
Pin No.	Name	Type	
1	XTALN	O/P	The output of the on-chip Xtal oscillator inverter.
2	XTAL/CLOCK	I/P	The input to the oscillator inverter from the Xtal circuit or external clock source.
3	SERCK	I/P	The 'C-BUS' serial clock input from the host μ C. See section 1.5.8
4	COMDATA	I/P	The 'C-BUS' serial data input from the host μ C.
5	REPDATA	T/S	A 3-state 'C-BUS' serial data output to the host μ C. This output is high impedance when not sending data to the host μ C.
6	CSN	I/P	The 'C-BUS' transfer control input provided by the host μ C.
7	IRQN	O/P	A 'wire-ORable' output for connection to a host μ C Interrupt Request input. This output is pulled down to V_{SS} when active and is high impedance when inactive. An external pullup resistor is required.
8	V_{SS}	Power	The negative supply rail (ground).
9	TONEFSK	O/P	The sinewave output of the Tones and FSK signal generators.
10	SPM	O/P	The sinewave output of the SPM signal generator.

CMX615 D4/P3	Signal		Description
	Pin No.	Name	
11	V_{BIAS}	O/P	An internally generated bias voltage of $V_{DD}/2$, except when the device is in 'Zero Power' mode when V_{BIAS} will discharge to V_{SS} . It should be decoupled to V_{SS} by a capacitor mounted close to the device pins.
12	OPPIN	I/P	The non-inverting input to the uncommitted amplifier.
13	OPNIN	I/P	The inverting input to the uncommitted amplifier.
14	OPOUT	O/P	The output of the uncommitted amplifier.
15	RING	O/P	The squarewave output of the Ringing Signal generator.
16	V_{DD}	Power	The positive supply rail. Levels within the device are proportional to this voltage. It should be decoupled to V_{SS} by a capacitor mounted close to the device pins.

Notes:

I/P = Input
 O/P = Output
 T/S = 3-state Output

It is recommended that the printed circuit board is laid out with a ground plane in the CMX615 area to provide a low impedance connection between the V_{SS} pin and the V_{DD} and V_{BIAS} decoupling capacitors.

1.4 External Components

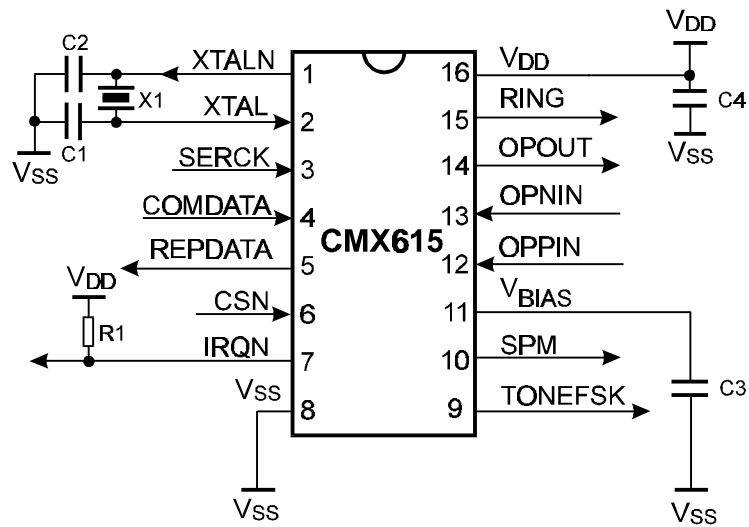

Figure 2 Recommended External Components

R1	100k ϕ	C1, C2	18pF
X1	3.579545 MHz	C3, C4	1.0 μ F

Resistors $\pm 5\%$, capacitors $\pm 10\%$ unless otherwise stated.

1.5 General Description

The CMX615 is a telecom tone generator and DTMF tone encoder. It has separate output ports for the three different classes of signals encoded. These include Ringing signal, In-band tones or FSK data at 1200bps and High frequency metering pulses (SPM tones). It has a transmit level attenuator for In-band tones or FSK data and an envelope control for SPM tones. It also has an uncommitted amplifier and uses the industry standard 3.58MHz Xtal for its oscillator. These functions are controlled over a 'C-BUS' serial μ C interface, which also carries the transmit FSK data.

The CMX615 may be powersaved into 'Zero-Power' mode for minimum power consumption by issuing a 'C-BUS' RESET command. Individual functions may be powersaved by the use of bits 6 and 7 in the SETUP Register. Not powersaving the Tx Powersave (set bit 6 of the SETUP Register to '1') will take the Tx functions (tone/FSK encoding, DTMF, SPM and Ringing signal generation) out of powersave. Not powersaving the Uncommitted Amplifier (Set bit 7 of the SETUP Register to '1') will take the amplifier out of powersave. Approximately 50ms should be allowed for the Tx dc level to settle at V_{BIAS} before enabling the Tx functions (set bit 6 of the MODE Register to '1').

1.5.1 Xtal Osc and Clock Dividers

Frequency and timing accuracy of the CMX615 is determined by a 3.579545MHz clock present at the XTAL/CLOCK pin. This may be generated by the on-chip oscillator inverter using the external components C1, C2 and X1 of Figure 2, or may be supplied from an external source to the XTAL/CLOCK input. If the clock is supplied from an external source, C1, C2 and X1 should not be fitted.

The on-chip oscillator is turned off in the 'Zero-Power' mode.

If the clock is provided by an external source which is not always running, then the 'Zero-Power' mode must be set when the clock is not available. Failure to observe this rule may cause a rise in the supply current drawn by CMX615.

1.5.2 Uncommitted Amplifier

This amplifier, with suitable external components, can be used for adjusting the transmit signal level (for the line hybrid).

1.5.3 Tone/FSK Encoder and Tone Encoder

When bit 5 of the MODE Register is set to '1' then these blocks generate FSK signals as determined by bit 0 of the SETUP Register and the Tx data bits from the UART block, as shown in the table below:

SETUP Register Bit 0	Tone/FSK Generator	FSK Signal Frequency '0' (Space)	FSK Signal Frequency '1' (Mark)
0	V23 1200bps FSK	2100Hz	1300Hz
1	Bell 202 1200bps FSK	2200Hz	1200Hz

When bit 5 of the MODE Register is set to '0', these blocks generate single or dual tones from the range shown in the tables on the following pages. Bit 6 of the MODE Register is then used to enable or disable the block's output to the Tx Signal Control, RING and TONEFSK outputs. There are four tone fields addressed by bits 0 and 1 of the MODE Register.

Tone Field 0, MODE Register bit 1 and bit 0 = '0' and '0' respectively.

TX TONES Register Bits 4-7				Frequency (Hz)	TX TONES Register Bits 0-3				Frequency (Hz)
D7	D6	D5	D4		D3	D2	D1	D0	
0	0	0	0	0 = OFF	0	0	0	0	0 = OFF
0	0	0	1	252.4	0	0	0	1	* 17.1
0	0	1	0	268.7	0	0	1	0	* 20.5
0	0	1	1	285.3	0	0	1	1	* 24.9
0	1	0	0	315.5	0	1	0	0	* 34.1
0	1	0	1	330.5	0	1	0	1	* 41.0
0	1	1	0	375.2	0	1	1	0	* 51.2
0	1	1	1	404.3	0	1	1	1	-
1	0	0	0	468.0	1	0	0	0	262.9
1	0	0	1	495.8	1	0	0	1	293.6
1	0	1	0	520.6	1	0	1	0	348.2
1	0	1	1	548.0	1	0	1	1	392.6
1	1	0	0	562.8	1	1	0	0	1600
1	1	0	1	578.4	1	1	0	1	1633
1	1	1	0	595.0	1	1	1	0	1827
1	1	1	1	612.5	1	1	1	1	587.2

NOTE: * These outputs are routed to the RING digital output instead of the TONEFSK output. Any single tone output level at TONEFSK output is 0dBm.

Tone Field 1, MODE Register bit 1 and bit 0 = '0' and '1' respectively

TX TONES Register Bits 4-7				Frequency (Hz)	TX TONES Register Bits 0-3				Frequency (Hz)
D7	D6	D5	D4		D3	D2	D1	D0	
0	0	0	0	0 = OFF	0	0	0	0	0 = OFF
0	0	0	1	120	0	0	0	1	330
0	0	1	0	150	0	0	1	0	416
0	0	1	1	154	0	0	1	1	420
0	1	0	0	250	0	1	0	0	425
0	1	0	1	300	0	1	0	1	433
0	1	1	0	350	0	1	1	0	440
0	1	1	1	360	0	1	1	1	450
1	0	0	0	367	1	0	0	0	460
1	0	0	1	375	1	0	0	1	480
1	0	1	0	380	1	0	1	0	500
1	0	1	1	383	1	0	1	1	600
1	1	0	0	400	1	1	0	0	620
1	1	0	1	450	1	1	0	1	720
1	1	1	0	475	1	1	1	0	930
1	1	1	1	480	1	1	1	1	-

Tone Field 2, MODE Register bit 1 and bit 0 = '1' and '0' respectively

TX TONES Register Bits				Frequency (Hz)	TX TONES Register Bits				Frequency (Hz)
D7	D6	D5	4-7 D4		D3	D2	D1	0-3 D0	
0	0	0	0	0 = OFF	0	0	0	0	0 = OFF
0	0	0	1	700	0	0	0	1	700
0	0	1	0	900	0	0	1	0	900
0	0	1	1	1100	0	0	1	1	1100
0	1	0	0	1300	0	1	0	0	1300
0	1	0	1	1500	0	1	0	1	1500
0	1	1	0	1700	0	1	1	0	1700
0	1	1	1	-	0	1	1	1	-
1	0	0	0	950	1	0	0	0	2100
1	0	0	1	1400	1	0	0	1	2225
1	0	1	0	1800	1	0	1	0	-
1	0	1	1	2130	1	0	1	1	2750
1	1	0	0	697	1	1	0	0	1209
1	1	0	1	770	1	1	0	1	1336
1	1	1	0	852	1	1	1	0	1477
1	1	1	1	941	1	1	1	1	1633

Tone Field 3, MODE Register bit 1 and bit 0 = '1' and '1' respectively

TX TONES Register Bits				Frequency (Hz)	TX TONES Register Bits				Frequency (Hz)
D7	D6	D5	4-7 D4		D3	D2	D1	0-3 D0	
0	0	0	0	0 = OFF	0	0	0	0	0 = OFF
0	0	0	1	540	0	0	0	1	540
0	0	1	0	660	0	0	1	0	660
0	0	1	1	780	0	0	1	1	780
0	1	0	0	900	0	1	0	0	900
0	1	0	1	1020	0	1	0	1	1020
0	1	1	0	1140	0	1	1	0	1140
0	1	1	1	-	0	1	1	1	-
1	0	0	0	1380	1	0	0	0	1380
1	0	0	1	1500	1	0	0	1	1500
1	0	1	0	1620	1	0	1	0	1620
1	0	1	1	1740	1	0	1	1	1740
1	1	0	0	1860	1	1	0	0	1860
1	1	0	1	1980	1	1	0	1	1980
1	1	1	0	-	1	1	1	0	-
1	1	1	1	-	1	1	1	1	-

1.5.4 SPM Generator

This block operates independently and has its own output pin. It can transmit 12kHz or 16kHz and is controlled by bit 4 of the SETUP Register. Bit 7 of the MODE Register is used to enable or disable this block. The signal has a rise and fall time each of about 4.5ms. The SPM signal rises from the bias level to 0dBm in 16 steps of 2dB magnitude, and falls from 0dBm to bias level in 16 steps of 2dB magnitude.

1.5.5 Transmit Signal Control

This block adjusts the amplitude of the FSK transmit signal output level, the level skew between DTMF tones and the signal routing to the output ports.

Output signal levels are proportional to V_{DD} . The nominal output signal levels (at 0dB attenuation and $V_{DD} = 5.0V$) are:

Single Tone	0dBm
Dual Tone (per tone)	-3dBm
DTMF High Frequency Tone	-3dBm
DTMF Low Frequency Tone	-5dBm
FSK Signal	0dBm

The RING signal is digital: a square wave with amplitude of $\approx V_{DD}$ peak to peak. When the RING signal is not selected, the RING output pin is connected to V_{SS} .

The level attenuator provides for level adjustment from 0dB to -14dB in -2dB steps. The typical level is determined by bits 2 to 4 of the MODE Register as shown in the table below:

MODE Register			Signal Level Adjustment
Bit 4	Bit 3	Bit 2	(dB)
0	0	0	0
0	0	1	-2
0	1	0	-4
0	1	1	-6
1	0	0	-8
1	0	1	-10
1	1	0	-12
1	1	1	-14

1.5.6 Tx UART

This block connects the μC , via the 'C-BUS' interface, to the FSK Encoder.

The block can be programmed to convert transmit data from 8-bit bytes to asynchronous data characters by adding Start and Stop bits. The transmit data is then passed to the FSK Encoder.

Data to be transmitted should be loaded by the μC into the TX DATA Register when the Tx Data Ready bit (bit 6) of the STATUS Register goes high. It will then be treated by the Tx UART block in one of two ways, depending on the setting of bit 1 of the SETUP Register:

If bit 1 of the SETUP Register is '0' (Tx Sync mode) then the 8 bits from the TX DATA Register will be transmitted sequentially at 1200bps, lsb (D0) first.

If bit 1 of the SETUP Register is '1' (Tx Async mode) then bits will be transmitted as asynchronous data characters at 1200 bps according to the following format:

- One Start bit (Space)
- Eight Data bits (D0-D7) from the TX DATA Register, with the lsb (D0) transmitted first
- One Stop bit (Mark)

Failure to load the TX DATA Register with a new value when required will result in bit 7 (Tx Data Underflow) of the STATUS Register being set to '1'. If the 'Tx Async' mode of operation is selected then a continuous Mark ('1') signal will be transmitted until a new value is loaded into TX DATA. If the 'Tx Sync' mode is selected then the byte already in the TX DATA Register will be re-transmitted.

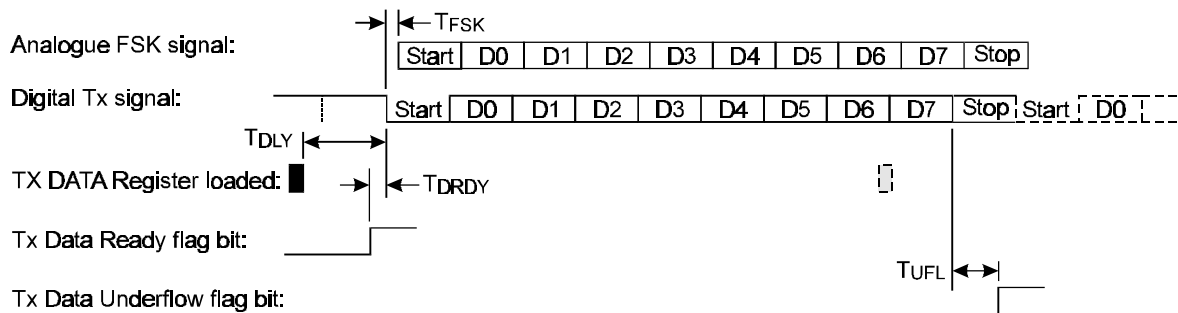

Figure 3a Async mode

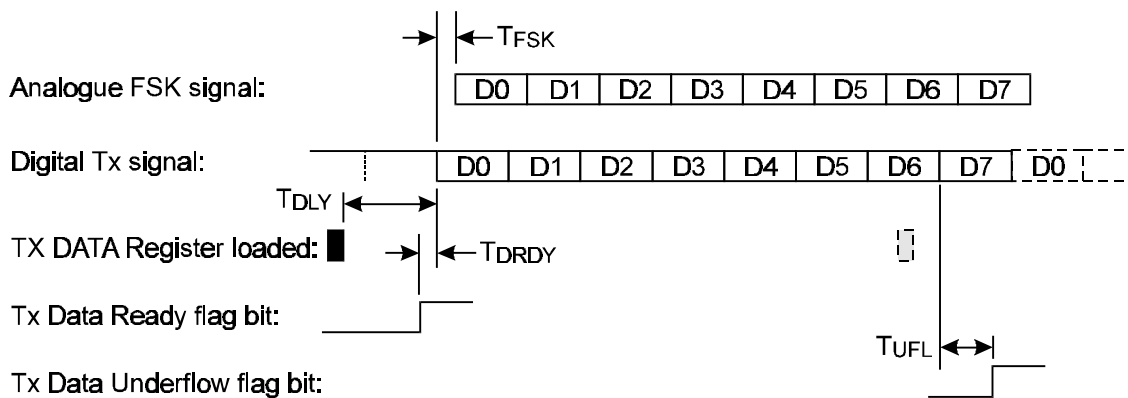

Figure 3b Sync mode

1.5.7 'C-BUS' Interface

This block provides for the transfer of data and control or status information between the CMX615's internal registers and the μC over the 'C-BUS' serial bus. Each transaction consists of a single Register Address byte sent from the μC which may be followed by a single data byte sent from the μC to be written into one of the CMX615's Write Only Registers, or a single byte of data read out from one of the CMX615's Read Only Registers, as illustrated in Figure 4.

Data sent from the μC on the Command Data (COMDATA) line is clocked into the CMX615 on the rising edge of the Serial Clock (SERCK) input. Reply Data (REPDATA) sent from the CMX615 to the μC is valid when the Serial Clock is high. The interface is compatible with the most common μC serial interfaces such as SCI, SPI and Microwire, and may also be easily implemented with general purpose μC I/O pins controlled by a simple software routine. See Figure 8 for detailed 'C-BUS' timing requirements.

a) Single byte from μ C

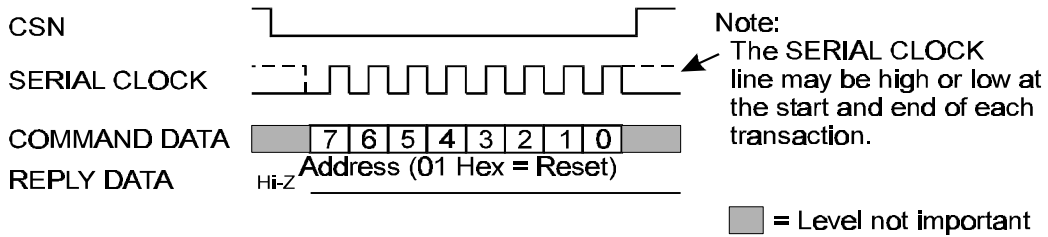

b) One Address and one Data byte from μ C

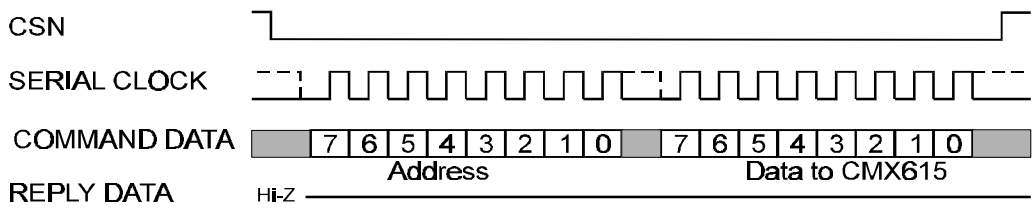

c) One Address byte from μ C and one Reply byte from CMX615

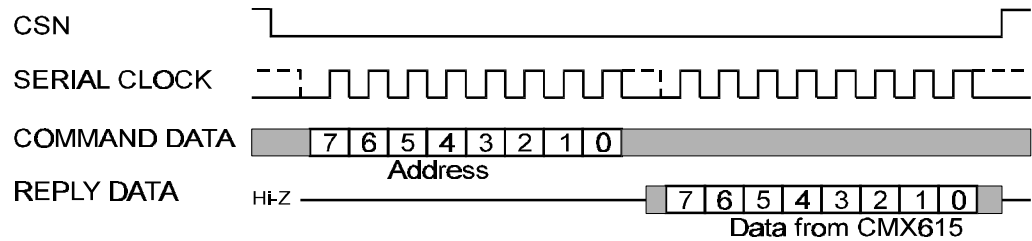

Figure 4 'C-BUS' Transactions

1.5.8 'C-BUS' Registers

Write Only Registers

Addr.	Register	Command Data Byte (Bits 7 - 0)								
		7	6	5	4	3	2	1	0	
\$01	RESET	N/A	N/A	N/A	N/A	N/A	N/A	N/A	N/A	
\$D0	SETUP	Uncommitted Amplifier: 0 = Powersave 1 = Not Powersave	Tx Powersave: 0 = Powersave 1 = Not Powersave	Reserved set to 0	SPM: 0 = 12kHz 1 = 16kHz	Reserved set to 0	Reserved set to 0	Reserved set to 0	FSK mode: 0 = Sync 1 = Async	FSK mode: 0 = V23 1 = Bell 202
\$D1	MODE	SPM O/P: 0 = Disable 1 = Enable	Tone/FSK: 0 = Disable 1 = Enable	Tone/FSK: 0 = Tone 1 = FSK	Tx Level: (msb)	Tx Level:	Tx Level: (lsb)	Tone Fields: (msb)	Tone Fields: (lsb)	
\$D3	TX DATA	D7	D6	D5	D4	D3	D2	D1	D0	
\$D4	TX TONES	D7	D6	D5	D4	D3	D2	D1	D0	

Read Only Registers

Addr.	Register	Reply Data Byte (Bits 7 - 0)							
		7	6	5	4	3	2	1	0
\$DF	STATUS	FSK Mode: FSK Tx Data Underflow	FSK Mode: FSK Tx Data Ready	Reserved set to 0	Reserved set to 0	Reserved set to 0	Reserved set to 0	Reserved set to 0	Reserved set to 0

Notes:

1. Accessing the RESET Register over the 'C-BUS' clears all of the bits in the SETUP, MODE, TX DATA, TX TONES and STATUS registers. This will set the device into the Zero Power mode. Note that this is a single-byte 'C-BUS' transaction consisting solely of the address byte value \$01.
2. If any of bits 6 or 7 of the STATUS Register is '1' then the IRQN output will be pulled low.
3. Reading the STATUS Register clears the IRQN output. Bits 6 and 7 of the STATUS Register are cleared on writing to the TX DATA Register.

1.6 Application Notes

When using the Tone/FSK bit (bit 6) of the MODE Register, each tone starts from V_{BIAS} and returns to V_{BIAS} before ending:

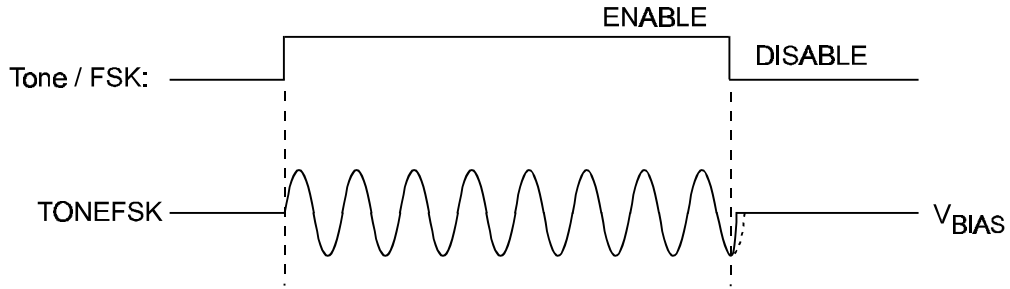

Figure 5 Tone Starting and Stopping

When switching between tones in the same column (bits 4 - 7 or bits 0 - 3) of the TX TONES Register), the transition will be phase continuous. However, switching to the “OFF” state will immediately take the output of that tone generator to V_{BIAS} .

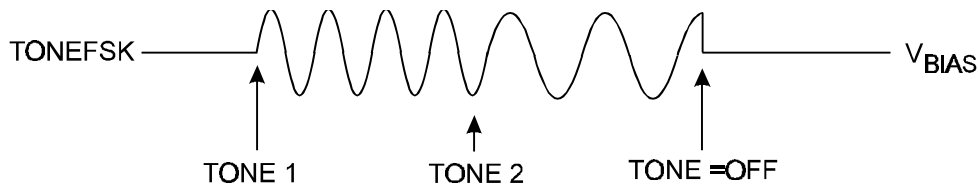

Figure 6 Tone Changing

TX TONES Register decodes which do not have a frequency allocated are indicated by a dash (-) in the Tone Field tables. These values should not be used.

1.6.1 ‘Telecom Tones

The following tables give the hex codes to be programmed into the particular tone field location for various telecommunications systems applications. The tables are not exhaustive, but list the more commonly used tones.

Ringing Signals

(f \pm 2.5%) (Hz) Off	Field 0 (Hex)
16.7	\$01
20	\$02
25	\$03
35	\$04
40	\$05
50	\$06

On Hook 'CPE Alert Tones

Single Tone (Hz)	Field 0 (Hex)
375.2	\$60
404.3	\$70
468	\$80
495.8	\$90
520.6	\$A0
548	\$B0
562.8	\$C0
578.4	\$D0
1633	\$0D

Dual Tone (Hz)	Field 0 (Hex)
375.2+1827	\$6E
404.3+1827	£7E
468+1827	\$8E
495.8+1827	\$9E
520.6+1827	\$AE
548+1827	\$BE
562.8+1827	\$CE
578.4+1827	\$DE

NYNEX (MRAA) - AMR Alert Tones (Single Tone)

Group A (Hz)	Field 0 (Hex)
252.4	\$10
268.7	\$20
285.3	\$30
315.5	\$40
330.5	\$50
375.2	\$60

Group B (Hz)	Field 0 (Hex)
468	\$80
495.8	\$90
520.6	\$A0
562.8	\$C0
595	\$E0
612.5	\$F0

Single Frequency Call Progress Tones

(Hz)	Field 1 (Hex)
Off	\$00
120	\$10
150	\$20
154	\$30
250	\$40
300	\$50
350	\$60
400	\$C0
425	\$04
440	\$06
450	\$07
480	\$09
500	\$0A
600	\$0B
620	\$0C

Dual Frequency Call Progress Tones

Additive Mixing (Hz)	Field 1 (Hex)
Off	\$00
350+440	\$66
440+480	\$F6
480+620	\$FC
400+425	\$C4
400+450	\$C7
425+450	\$D4
425+480	\$F4
120+620	\$1C
150+450	\$27

Multiplicative Mixing (Hz)	Field 1 (Hex)
400*16.2	\$B2
400*20	\$A3
400*25	\$94
400*33	\$85
400*40	\$76
400*50	\$67
450*25	\$E4
600*120	\$FD

Dual Tone Multi Frequency Generation

(Hz)	Field 2 (Hex)
Off	\$00
941+1633	\$FF
697+1209	\$CC
697+1336	\$CD
697+1477	\$CE
770+1209	\$DC
770+1336	\$DD
770+1477	\$DE
852+1209	\$EC
852+1336	\$ED
852+1477	\$EE
941+1336	\$FD
941+1209	\$FC
941+1477	\$FE
697+1633	\$CF
770+1633	\$DF
852+1633	\$EF

Special Information Tones, Fax and Modem Tones and Customer Premises Alert Tones

(Hz)	Field 2 (Hex)
Off	\$00
950	\$80
1100	\$30
1300	\$40
1400	\$90
1800	\$A0
2100	\$08
2225	\$09
2130+2750	\$BB

CCITT 'R1' Signalling Tones

(Hz)	Field 2 (Hex)
700+900	\$12
700+1100	\$13
900+1100	\$23
700+1300	\$14
900+1300	\$24
1100+1300	\$34
700+1500	\$15
900+1500	\$25
1100+1500	\$35
1300+1500	\$45
700+1700	\$16
900+1700	\$26
1100+1700	\$36
1300+1700	\$46
1500+1700	\$56

CCITT 'R2' Signalling Tones

Forward mode (Hz)	Field 3 (Hex)
Off	\$00
1380+1500	\$89
1380+1620	\$8A
1500+1620	\$9A
1380+1740	\$8B
1500+1740	\$9B
1620+1740	\$AB
1380+1860	\$8C
1500+1860	\$9C
1620+1860	\$AC
1740+1860	\$BC
1380+1980	\$8D
1500+1980	\$9D
1620+1980	\$AD
1740+1980	\$BD
1860+1980	\$CD

Backward mode (Hz)	Field 3 (Hex)
Off	\$00
1140+1020	\$65
1140+900	\$64
1020+900	\$54
1140+780	\$63
1020+780	\$53
900+780	\$43
1140+660	\$62
1020+660	\$52
900+660	\$42
780+660	\$32
1140+540	\$61
1020+540	\$51
900+540	\$41
780+540	\$31
660+540	\$21

1.6.2 'C-BUS Timing

The relationship between bytes loaded onto the C-BUS and the transmission of FSK bytes is shown diagrammatically in Figures 7a, 7b and 7c.

There are many ways in which the C-BUS can be used to program a device and three suggestions (one for asynchronous FSK - Figure 7a - and two for synchronous FSK - Figures 7b and 7c) are shown here, together with typical timings. Please note that the C-BUS timing is not shown to the same scale as the FSK output (it has been magnified by at least 20 times to make it visible on the same scale).

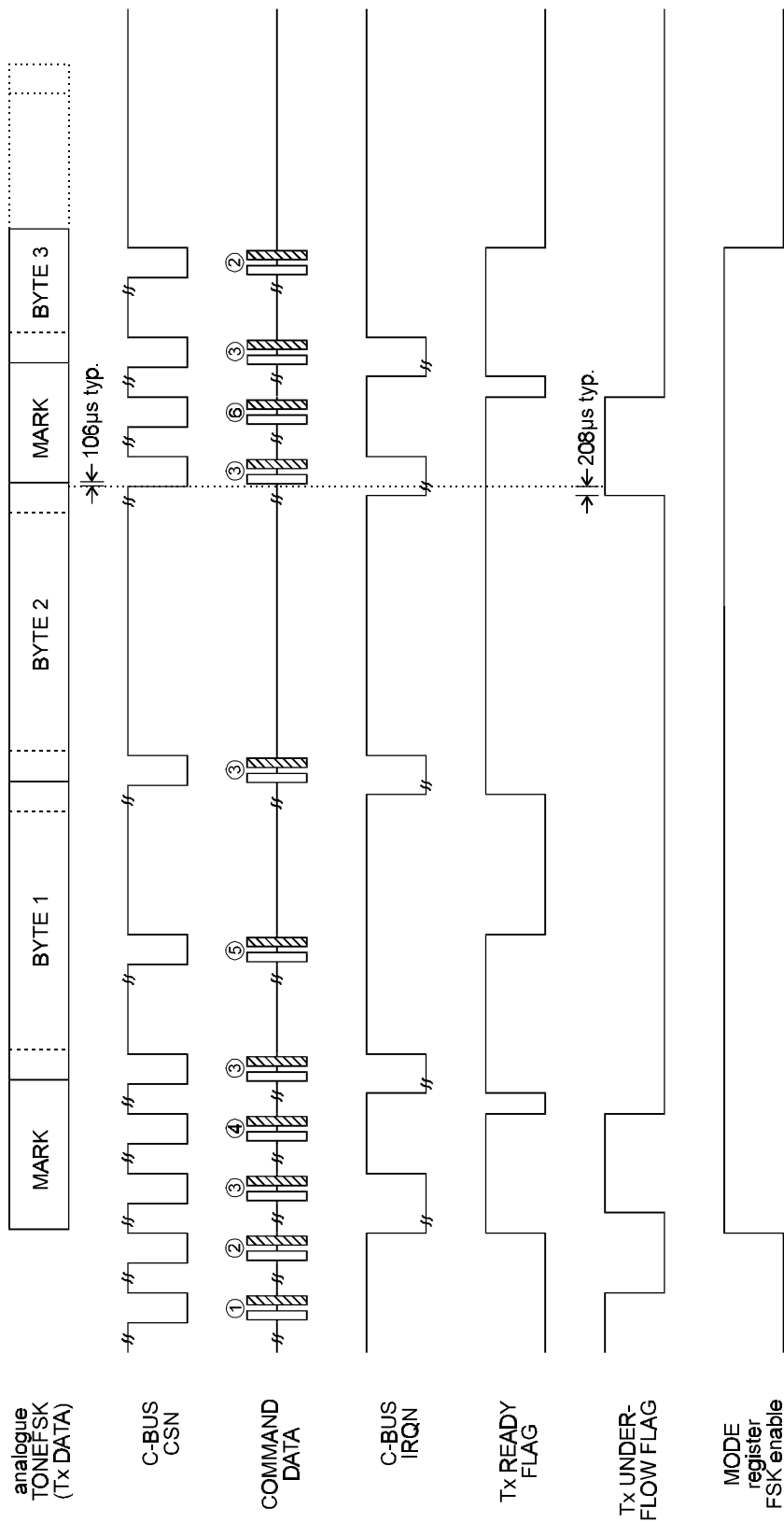

Bit Period = $\approx 833\mu\text{s typ.}$

- ① Configure SETUP (set B6=1 always)
- ② Configure MODE (set B6=1 to Enable)
- ③ Read STATUS
- ④ Load Tx DATA with BYTE 1
- ⑤ Load Tx DATA with BYTE 2
- ⑥ Load Tx DATA with BYTE 3

NOTE: C-BUS timing not shown to scale

Figure 7a ASYNC mode after General Reset

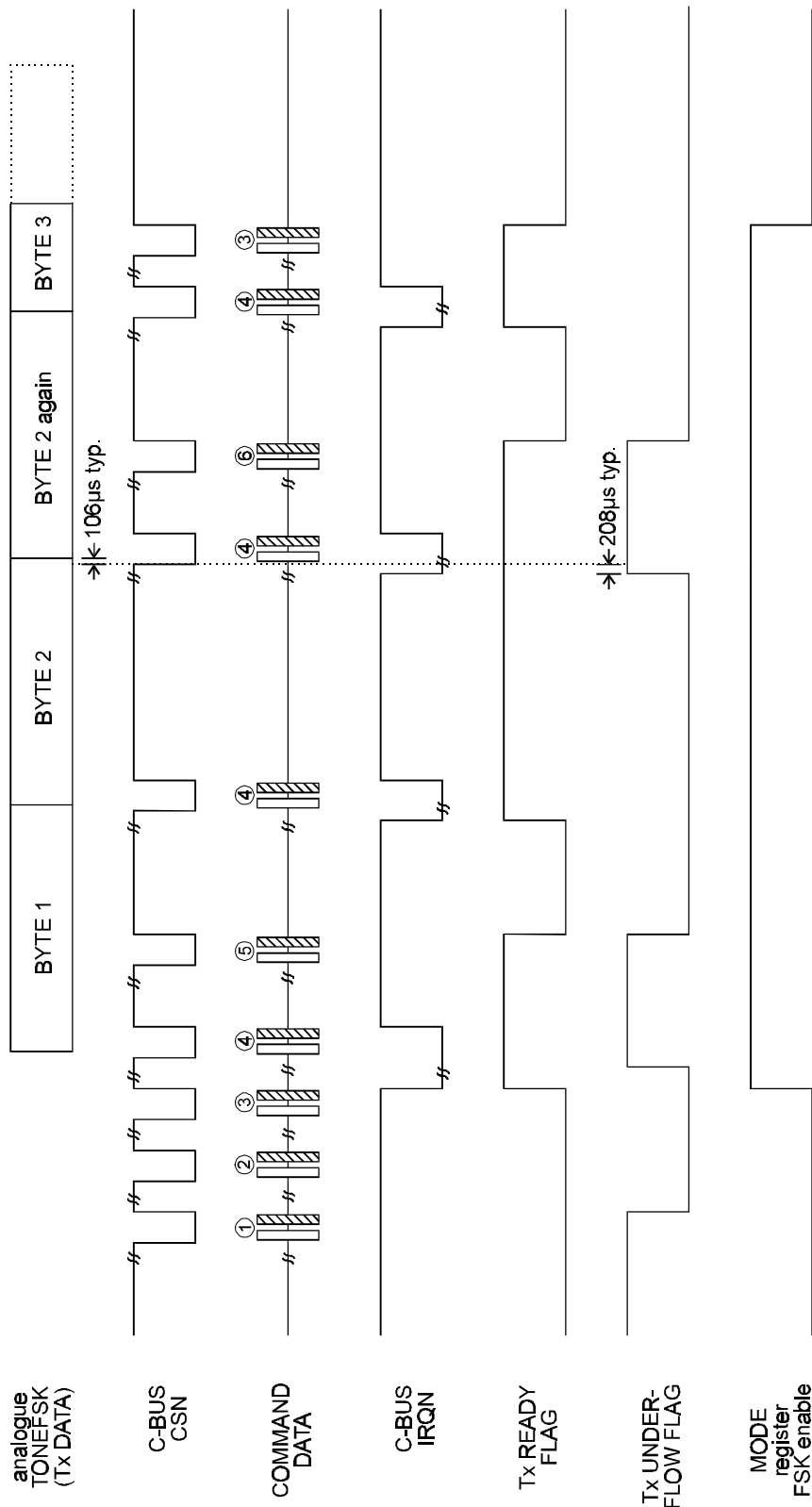

Bit Period = $\approx 106\mu\text{s typ.}$

- ① Configure SETUP (set B6=1 always)
- ② Load Tx DATA with BYTE 1
- ③ Configure MODE (set B6=1 to Enable)
- ④ Read STATUS
- ⑤ Load Tx DATA with BYTE 2
- ⑥ Load Tx DATA with BYTE 3

NOTE: C-BUS timing not shown to scale

Figure 7b SYNC mode after General Reset

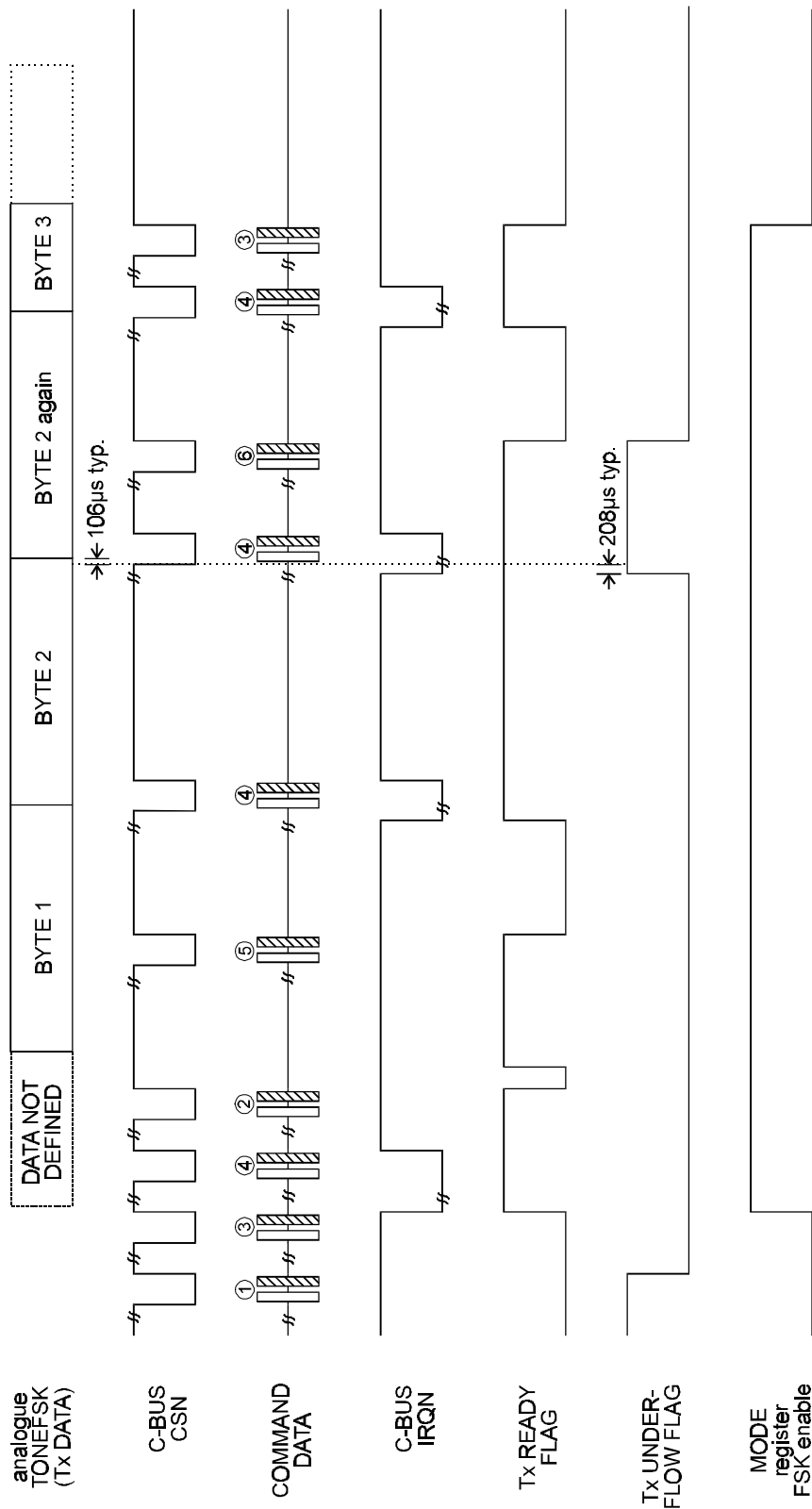

Bit Period = 833µs typ.

- ① Configure SETUP (set B6=1 always)
- ② Load Tx DATA with BYTE 1
- ③ Configure MODE (set B6=1 to Enable)
- ④ Read STATUS
- ⑤ Load Tx DATA with BYTE 2
- ⑥ Load Tx DATA with BYTE 3

NOTE: C-BUS timing not shown to scale

Figure 7c SYNC mode after General Reset (using alternative order of commands)

1.7 Performance Specification

1.7.1 Electrical Performance

1.7.1.1 Absolute Maximum Ratings

Exceeding these maximum ratings can result in damage to the device.

	Min.	Max.	Unit
Supply ($V_{DD} - V_{SS}$)	-0.3	7.0	V
Voltage on any pin to V_{SS}	-0.3	$V_{DD} + 0.3$	V
Current into or out of V_{DD} and V_{SS} pins	-50	+50	mA
Current into or out of any other pin	-20	+20	mA

D4/P3 Package	Min.	Max.	Unit
Total Allowable Power Dissipation at $T_{amb} = 25^{\circ}\text{C}$		800	mW
... Derating		13	mW/ $^{\circ}\text{C}$
Storage Temperature	-55	+125	$^{\circ}\text{C}$
Operating Temperature	-40	+85	$^{\circ}\text{C}$

1.7.1.2 Operating Limits

Correct operation of the device outside these limits is not implied.

	Notes	Min.	Max.	Unit
Supply ($V_{DD} - V_{SS}$)		2.7	5.5	V
Operating Temperature		-40	+85	$^{\circ}\text{C}$
Xtal Frequency	1	3.575965	3.583125	MHz

Notes: 1. A Xtal frequency of 3.579545MHz \pm 0.1% is required for correct operation.

1.7.1.3 Operating Characteristics

For the following conditions unless otherwise specified:

$V_{DD} = 2.7V$ at $T_{amb} = 25^{\circ}C$ and $V_{DD} = 3.0V$ to $5.5V$ at $T_{amb} = -40$ to $+85^{\circ}C$,

Xtal Frequency = $3.579545MHz \pm 0.1\%$

0dBm corresponds to 775mVrms.

DC Parameters	Notes	Min.	Typ.	Max.	Unit
I_{DD} Zero-Power Mode	1, 2	-	<1.0	-	μA
OpAmp only Enabled, $V_{DD} = 5.0V$	1	-	1.5	-	mA
OpAmp only Enabled, $V_{DD} = 3.3V$	1	-	0.75	-	mA
All Enabled, $V_{DD} = 5.0V$	1	-	5.0	7.5	mA
All Enabled, $V_{DD} = 3.3V$	1	-	3.0	4.5	mA
Logic '1' Input Level	3	70%	-	-	V_{DD}
Logic '0' Input Level	3	-	-	30%	V_{DD}
Logic Input Leakage Current ($V_{in} = 0$ to V_{DD}), (excluding XTAL/CLOCK input)	3	-1.0	-	+1.0	μA
Output Logic '1' Level ($I_{OH} = 360\mu A$)		$V_{DD}-0.4$	-	-	V
Output Logic '0' Level ($I_{OL} = 360\mu A$)		-	-	0.4	V
IRQN O/P 'Off State Current ($V_{OUT} = V_{DD}$)		-	-	1.0	μA

FSK Encoder and Tx UART	Notes	Min.	Typ.	Max.	Unit
Level at TONEFSK pin	4	-1.0	0.0	1.0	dBm
Twist (Mark level WRT Space level)		-2.0	0	+2.0	dB
Tx 1200bits/sec (V23 mode)					
Baud Rate (set by UART and Xtal frequency)		1194	1200	1206	Baud
Mark (Logical 1) Frequency		1297	1300	1303	Hz
Space (Logical 0) Frequency		2097	2100	2103	Hz
Tx 1200bits/sec (Bell 202 mode)					
Baud Rate (set by UART and Xtal frequency)		1194	1200	1206	Baud
Mark (Logical 1) Frequency		1197	1200	1203	Hz
Space (Logical 0) Frequency		2197	2200	2203	Hz

TONEFSK Signal Level	Notes	Min.	Typ.	Max.	Unit
Level at TONEFSK pin for:					
Single tone	4	-1.0	0	1.0	dBm
Dual tone (per tone)	4	-4.0	-3.0	-2.0	dBm
DTMF High Frequency Group	4	-4.0	-3.0	-2.0	dBm
DTMF Low Frequency Group	4	-6.0	-5.0	-4.0	dBm
Output Impedance		-	10.0	-	k Ω
Tone frequency resolution		-2.0	-	2.0	Hz
Tone output distortion	5	-	0.8	-	%

- Notes:
- At $25^{\circ}C$, not including any current drawn from the CMX615 pins by external circuitry other than X1, C1 and C2.
 - All logic inputs at V_{SS} except for CSN input which is at V_{DD} .
 - Excluding XTAL/CLOCK pin.
 - At $V_{DD} = 5.0V$, load resistance greater than $40k\Omega$, signal levels are proportional to V_{DD} .
 - Frequency above 300Hz.
 - SPM has a soft rise and fall time of about 4.5ms. The level changes between V_{BIAS} and 0dBm in 2dB steps, 16 steps per rise and fall. When SPM is disabled, an extra 4.5ms falling tail end of signal should be taken into consideration.

SPM Signal Level	Notes	Min.	Typ.	Max.	Unit
Level at SPM pin	4, 6	-1.5	0	1.0	dBm
	4,6,8	-1.0	0	0.5	dBm
Tone frequency accuracy		-14.0	-	14.0	Hz
Tone output distortion	5	-	1.2	-	%
Output Impedance		-	10.0	-	k Ω

Uncommitted Amplifier	Notes	Min.	Typ.	Max.	Unit
Open Loop Gain (I/P = 1mVrms at 100Hz)		-	60.0	-	dB
Unity Gain Bandwidth		-	5.0	-	MHz
Input Impedance (at 100Hz)		10.0	-	-	M Ω
Output Impedance (Open Loop)		-	10.0	-	k Ω

Power-Up Timing	Notes	Min.	Typ.	Max.	Unit
Zero-Power to reliable signal at OPOUT, RING, SPM or TONEFSK output pins.		-	50	-	ms

XTAL/CLOCK Input	Notes	Min.	Typ.	Max.	Unit
'High' Pulse Width	7	100	-	-	ns
'Low' Pulse Width	7	100	-	-	ns
Input Impedance (at 100Hz)		-	1.0	-	M Ω
Gain (I/P = 1mVrms at 100Hz)		20.0	-	-	dB

- Notes:
7. Timing for an external input to the XTAL/CLOCK pin.
 8. Over the range $V_{DD} = 3.0$ to $5.5V$ at $T_{amb} = 25^{\circ}C$.

	Notes	Min.	Typ.	Max.	Unit
'C-BUS' Timings (See Figure 8)					
t_{CSE}	CSN-Enable to Clock-High time	100	-	-	ns
t_{CSH}	Last Clock-High to CSN-High time	100	-	-	ns
t_{LOZ}	Clock-Low to Reply Output enable time	0.0	-	-	ns
t_{HIZ}	CSN-High to Reply Output 3-state time	-	-	1.0	μ s
t_{CSOFF}	CSN-High Time between transactions	1.0	-	-	μ s
t_{NXT}	Inter-Byte Time	500	-	-	ns
t_{CK}	Clock-Cycle time	500	-	-	ns
t_{CH}	Serial Clock-High time	200	-	-	ns
t_{CL}	Serial Clock-Low time	200	-	-	ns
t_{CDS}	Command Data Set-Up time	75	-	-	ns
t_{CDH}	Command Data Hold time	25	-	-	ns
t_{RDS}	Reply Data Set-Up time	75	-	-	ns
t_{RDH}	Reply Data Hold time	0	-	-	ns

Note: These timings are for the latest version of the 'C-BUS' as embodied in the CMX615, and allow faster transfers than the original 'C-BUS' timings given in CML Publication D/800/Sys/3 July 1994.

	Notes	Min.	Typ.	Max.	Unit
Typical UART Timings (See Figure 3a and 3b)					
T_{FSK}	(delay through the modulator)	-	106	-	μ s
T_{DLY}	(1 bit-period)	-	833	-	μ s
T_{DRDY}	(1/4 bit-period)	-	208	-	μ s
T_{UFL}	(3/4 bit-period)	-	625	-	μ s

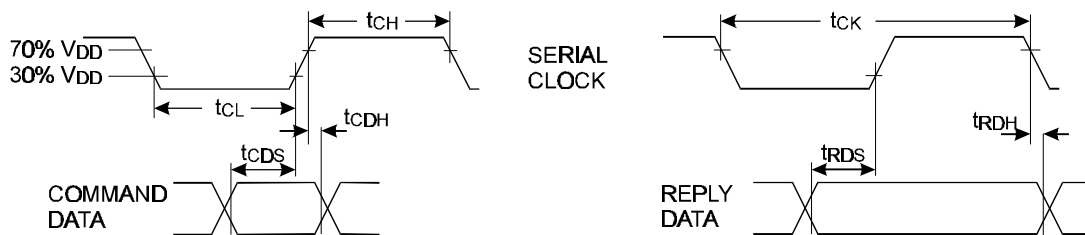
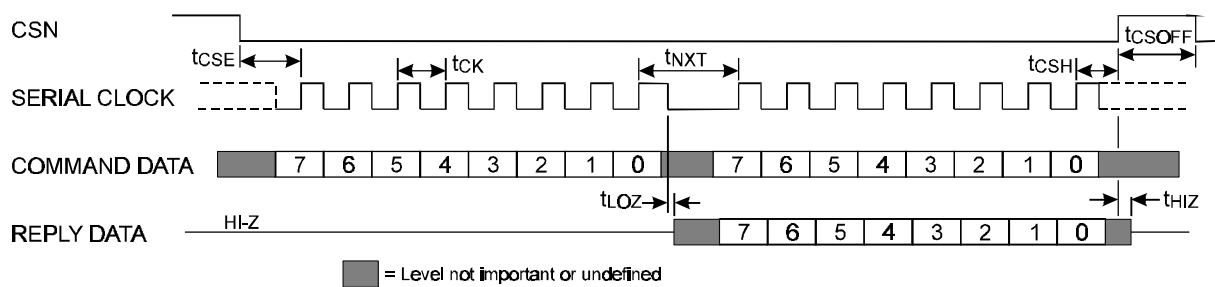
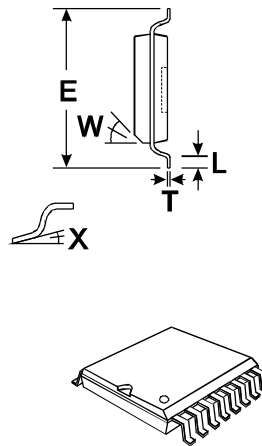
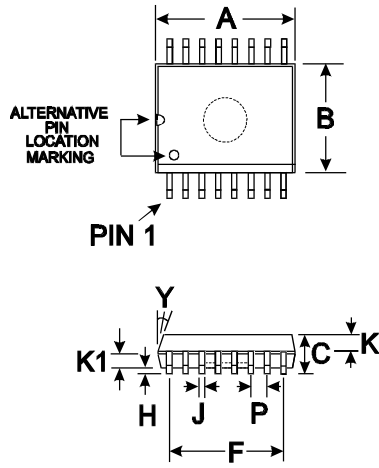

Figure 8 'C-BUS' Timing

1.7.2 Packaging



DIM.	MIN.	TYP.	MAX.
* A	0.395 (10.03)		0.413 (10.49)
* B	0.286 (7.26)		0.299 (7.59)
C	0.093 (2.36)		0.105 (2.67)
E	0.390 (9.90)		0.419 (10.64)
F		0.350 (8.89)	
H	0.003 (0.08)		0.020 (0.51)
J	0.013 (0.33)		0.020 (0.51)
K		0.041 (1.04)	
K1		0.041 (1.04)	
L	0.016 (0.41)		0.050 (1.27)
P		0.050 (1.27)	
T	0.009 (0.23)		0.0125 (0.32)
W		45°	
X		0°	10°
Y		7°	

NOTE :

* A & B are reference datum's and do not include mold deflash or protrusions.

All dimensions in inches (mm.)
Angles are in degrees

Figure 9 16-pin SOIC (D4) Mechanical Outline: Order as part no. CMX615D4

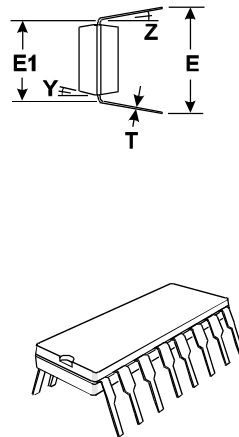
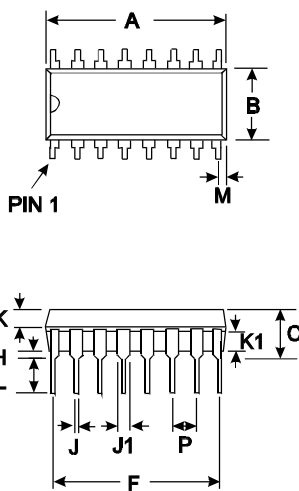

DIM.	MIN.	TYP.	MAX.
* A	0.740 (18.80)		0.810 (20.57)
* B	0.240 (6.10)		0.262 (6.65)
C	0.135 (3.43)		0.200 (5.08)
E	0.300 (7.62)		0.390 (9.91)
E1	0.290 (7.37)		0.325 (8.26)
F		0.70 (17.78)	
H	0.015 (0.38)		0.040 (1.02)
J	0.015 (0.38)		0.023 (0.58)
J1	0.040 (1.02)		0.065 (1.65)
K	0.056 (1.42)		0.064 (1.63)
K1	0.056 (1.42)		0.064 (1.63)
L	0.121 (3.07)		0.150 (3.81)
M		0.028 (0.71)	
P		0.100 (2.54)	
T	0.008 (0.20)		0.015 (0.38)
Y		7°	
Z		5°	

NOTE :

* A & B are reference datum's and do not include mold deflash or protrusions.

All dimensions in inches (mm.)
Angles are in degrees

Figure 10 16-pin DIL (P3) Mechanical Outline: Order as part no. CMX615P3

Handling precautions: This product includes input protection, however, precautions should be taken to prevent device damage from electro-static discharge. CML does not assume any responsibility for the use of any circuitry described. No IPR or circuit patent licences are implied. CML reserves the right at any time without notice to change the said circuitry and this product specification. CML has a policy of testing every product shipped using calibrated test equipment to ensure compliance with this product specification. Specific testing of all circuit parameters is not necessarily performed.



Oval Park - LANGFORD
MALDON - ESSEX
CM9 6WG - ENGLAND

Telephone: +44 (0)1621 875500
Telefax: +44 (0)1621 875600
e-mail: sales@cmlmicro.co.uk
http://www.cmlmicro.co.uk



CML Microcircuits

COMMUNICATION SEMICONDUCTORS

CML Product Data

In the process of creating a more global image, the three standard product semiconductor companies of CML Microsystems Plc (*Consumer Microcircuits Limited (UK)*, *MX-COM, Inc (USA)* and *CML Microcircuits (Singapore) Pte Ltd*) have undergone name changes and, whilst maintaining their separate new names (*CML Microcircuits (UK) Ltd*, *CML Microcircuits (USA) Inc* and *CML Microcircuits (Singapore) Pte Ltd*), now operate under the single title **CML Microcircuits**.

These companies are all 100% owned operating companies of the CML Microsystems Plc Group and these changes are purely changes of name and do not change any underlying legal entities and hence will have no effect on any agreements or contacts currently in force.

CML Microcircuits Product Prefix Codes

Until the latter part of 1996, the differentiator between products manufactured and sold from MXCOM, Inc. and Consumer Microcircuits Limited were denoted by the prefixes MX and FX respectively. These products use the same silicon etc. and today still carry the same prefixes. In the latter part of 1996, both companies adopted the common prefix: CMX.

This notification is relevant product information to which it is attached.

Company contact information is as below:



**CML Microcircuits
(UK) Ltd**

COMMUNICATION SEMICONDUCTORS

Oval Park, Langford, Maldon,
Essex, CM9 6WG, England
Tel: +44 (0)1621 875500
Fax: +44 (0)1621 875600
uk.sales@cmlmicro.com
www.cmlmicro.com



**CML Microcircuits
(USA) Inc.**

COMMUNICATION SEMICONDUCTORS

4800 Bethania Station Road,
Winston-Salem, NC 27105, USA
Tel: +1 336 744 5050,
0800 638 5577
Fax: +1 336 744 5054
us.sales@cmlmicro.com
www.cmlmicro.com



**CML Microcircuits
(Singapore) Pte Ltd**

COMMUNICATION SEMICONDUCTORS

No 2 Kallang Pudding Road, 09-05/
06 Mactech Industrial Building,
Singapore 349307
Tel: +65 7450426
Fax: +65 7452917
sg.sales@cmlmicro.com
www.cmlmicro.com