

Video amplifier

NE592

DESCRIPTION

The NE592 is a monolithic, two-stage, differential output, wideband video amplifier. It offers fixed gains of 100 and 400 without external components and adjustable gains from 400 to 0 with one external resistor. The input stage has been designed so that with the addition of a few external reactive elements between the gain select terminals, the circuit can function as a high-pass, low-pass, or band-pass filter. This feature makes the circuit ideal for use as a video or pulse amplifier in communications, magnetic memories, display, video recorder systems, and floppy disk head amplifiers. Now available in an 8-pin version with fixed gain of 400 without external components and adjustable gain from 400 to 0 with one external resistor.

FEATURES

- 120MHz unity gain bandwidth
- Adjustable gains from 0 to 400
- Adjustable pass band
- No frequency compensation required
- Wave shaping with minimal external components
- MIL-STD processing available

PIN CONFIGURATIONS

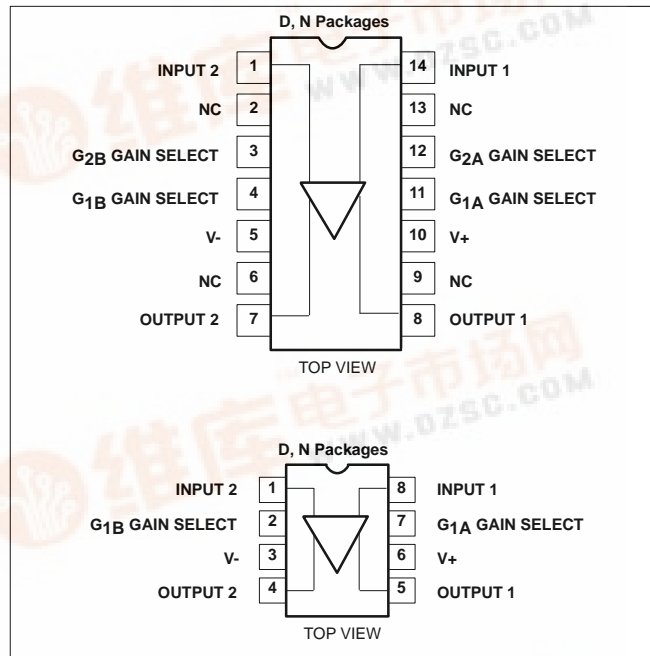

APPLICATIONS

- Floppy disk head amplifier
- Video amplifier
- Pulse amplifier in communications
- Magnetic memory
- Video recorder systems

BLOCK DIAGRAM

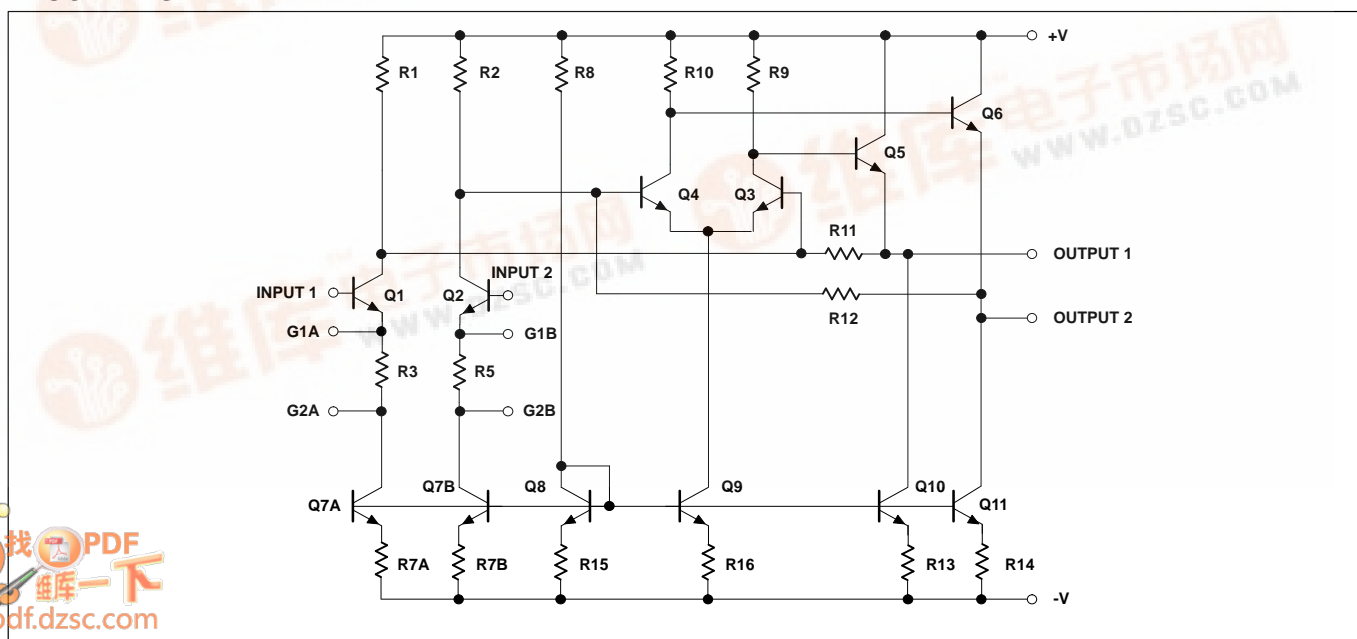

Video amplifier

NE592

ORDERING INFORMATION

DESCRIPTION	TEMPERATURE RANGE	ORDER CODE	DWG #
14-Pin Plastic Dual In-Line Package (DIP)	0 to +70°C	NE592N14	0405B
14-Pin Small Outline (SO) package	0 to +70°C	NE592D14	0175D
8-Pin Plastic Dual In-Line Package (DIP)	0 to +70°C	NE592N8	0404B
8-Pin Small Outline (SO) package	0 to +70°C	NE592D8	0174C

NOTES:

N8, N14, D8 and D14 package parts also available in "High" gain version by adding "H" before package designation, i.e., NE592HDB

ABSOLUTE MAXIMUM RATINGS

$T_A = +25^\circ\text{C}$, unless otherwise specified.

SYMBOL	PARAMETER	RATING	UNIT
V_{CC}	Supply voltage	± 8	V
V_{IN}	Differential input voltage	± 5	V
V_{CM}	Common-mode input voltage	± 6	V
I_{OUT}	Output current	10	mA
T_A	Operating ambient temperature range	0 to +70	°C
T_{STG}	Storage temperature range	-65 to +150	°C
$P_{D\ MAX}$	Maximum power dissipation, $T_A = 25^\circ\text{C}$ (still air) ¹		
	D-14 package	0.98	W
	D-8 package	0.79	W
	N-14 package	1.44	W
	N-8 package	1.17	W

NOTES:

- Derate above 25°C at the following rates:
 - D-14 package at 7.8mW/°C
 - D-8 package at 6.3mW/°C
 - N-14 package at 11.5mW/°C
 - N-8 package at 9.3mW/°C

Video amplifier

NE592

DC ELECTRICAL CHARACTERISTICS

$T_A=+25^\circ\text{C}$ $V_{SS}=\pm 6\text{V}$, $V_{CM}=0$, unless otherwise specified. Recommended operating supply voltages $V_S=\pm 6.0\text{V}$. All specifications apply to both standard and high gain parts unless noted differently.

SYMBOL	PARAMETER	TEST CONDITIONS	NE592			UNIT
			Min	Typ	Max	
A_{VOL}	Differential voltage gain, standard part	$R_L=2\text{k}\Omega$, $V_{OUT}=3\text{V}_{P-P}$				
	Gain 1 ¹		250	400	600	V/V
	Gain 2 ^{2, 4}		80	100	120	V/V
R_{IN}	Input resistance					
	Gain 1 ¹			4.0		k Ω
	Gain 2 ^{2, 4}		10	30		k Ω
C_{IN}	Input capacitance ²	Gain 2 ⁴		2.0		pF
I_{OS}	Input offset current			0.4	5.0	μA
I_{BIAS}	Input bias current			9.0	30	μA
V_{NOISE}	Input noise voltage	BW 1kHz to 10MHz		12		μV_{RMS}
V_{IN}	Input voltage range		± 1.0			V
CMRR	Common-mode rejection ratio					
	Gain 2 ⁴	$V_{CM}\pm 1\text{V}$, $f<100\text{kHz}$	60	86		dB
	Gain 2 ⁴	$V_{CM}\pm 1\text{V}$, $f=5\text{MHz}$		60		dB
PSRR	Supply voltage rejection ratio					
	Gain 2 ⁴	$\Delta V_S=\pm 0.5\text{V}$	50	70		dB
V_{OS}	Output offset voltage					
	Gain 1	$R_L=\infty$			1.5	V
	Gain 2 ⁴	$R_L=\infty$			1.5	V
	Gain 3 ³	$R_L=\infty$		0.35	0.75	V
V_{CM}	Output common-mode voltage	$R_L=\infty$	2.4	2.9	3.4	V
V_{OUT}	Output voltage swing differential	$R_L=2\text{k}\Omega$	3.0	4.0		V
R_{OUT}	Output resistance			20		Ω
I_{CC}	Power supply current	$R_L=\infty$		18	24	mA

NOTES:

- Gain select Pins G_{1A} and G_{1B} connected together.
- Gain select Pins G_{2A} and G_{2B} connected together.
- All gain select pins open.
- Applies to 14-pin version only.

Video amplifier

NE592

DC ELECTRICAL CHARACTERISTICS

DC Electrical Characteristics $V_{SS}=\pm 6V$, $V_{CM}=0$, $0^{\circ}C \leq T_A \leq 70^{\circ}C$, unless otherwise specified. Recommended operating supply voltages $V_S=\pm 6.0V$. All specifications apply to both standard and high gain parts unless noted differently.

SYMBOL	PARAMETER	TEST CONDITIONS	NE592			UNIT
			Min	Typ	Max	
A_{VOL}	Differential voltage gain, standard part Gain 1 ¹ Gain 2 ^{2, 4}	$R_L=2k\Omega$, $V_{OUT}=3V_{P-P}$	250		600	V/V
			80		120	V/V
R_{IN}	Input resistance Gain 2 ^{2, 4}		8.0			k Ω
I_{OS}	Input offset current				6.0	μA
I_{BIAS}	Input bias current				40	μA
V_{IN}	Input voltage range		± 1.0			V
CMRR	Common-mode rejection ratio Gain 2 ⁴	$V_{CM}\pm 1V$, $f<100kHz$	50			dB
PSRR	Supply voltage rejection ratio Gain 2 ⁴	$\Delta V_S=\pm 0.5V$	50			dB
V_{OS}	Output offset voltage Gain 1 Gain 2 ⁴ Gain 3 ³	$R_L=\infty$			1.5	V
					1.5	
					1.0	
V_{OUT}	Output voltage swing differential	$R_L=2k\Omega$	2.8			V
I_{CC}	Power supply current	$R_L=\infty$			27	mA

NOTES:

- Gain select Pins G_{1A} and G_{1B} connected together.
- Gain select Pins G_{2A} and G_{2B} connected together.
- All gain select pins open.
- Applies to 14-pin versions only.

AC ELECTRICAL CHARACTERISTICS

$T_A=+25^{\circ}C$ $V_{SS}=\pm 6V$, $V_{CM}=0$, unless otherwise specified. Recommended operating supply voltages $V_S=\pm 6.0V$. All specifications apply to both standard and high gain parts unless noted differently.

SYMBOL	PARAMETER	TEST CONDITIONS	NE/SA592			UNIT
			Min	Typ	Max	
BW	Bandwidth Gain 1 ¹ Gain 2 ^{2, 4}			40		MHz
				90		MHz
t_R	Rise time Gain 1 ¹ Gain 2 ^{2, 4}	$V_{OUT}=1V_{P-P}$		10.5	12	ns
				4.5		ns
t_{PD}	Propagation delay Gain 1 ¹ Gain 2 ^{2, 4}	$V_{OUT}=1V_{P-P}$		7.5	10	ns
				6.0		ns

NOTES:

- Gain select Pins G_{1A} and G_{1B} connected together.
- Gain select Pins G_{2A} and G_{2B} connected together.
- All gain select pins open.
- Applies to 14-pin versions only.

Video amplifier

NE592

TYPICAL PERFORMANCE CHARACTERISTICS

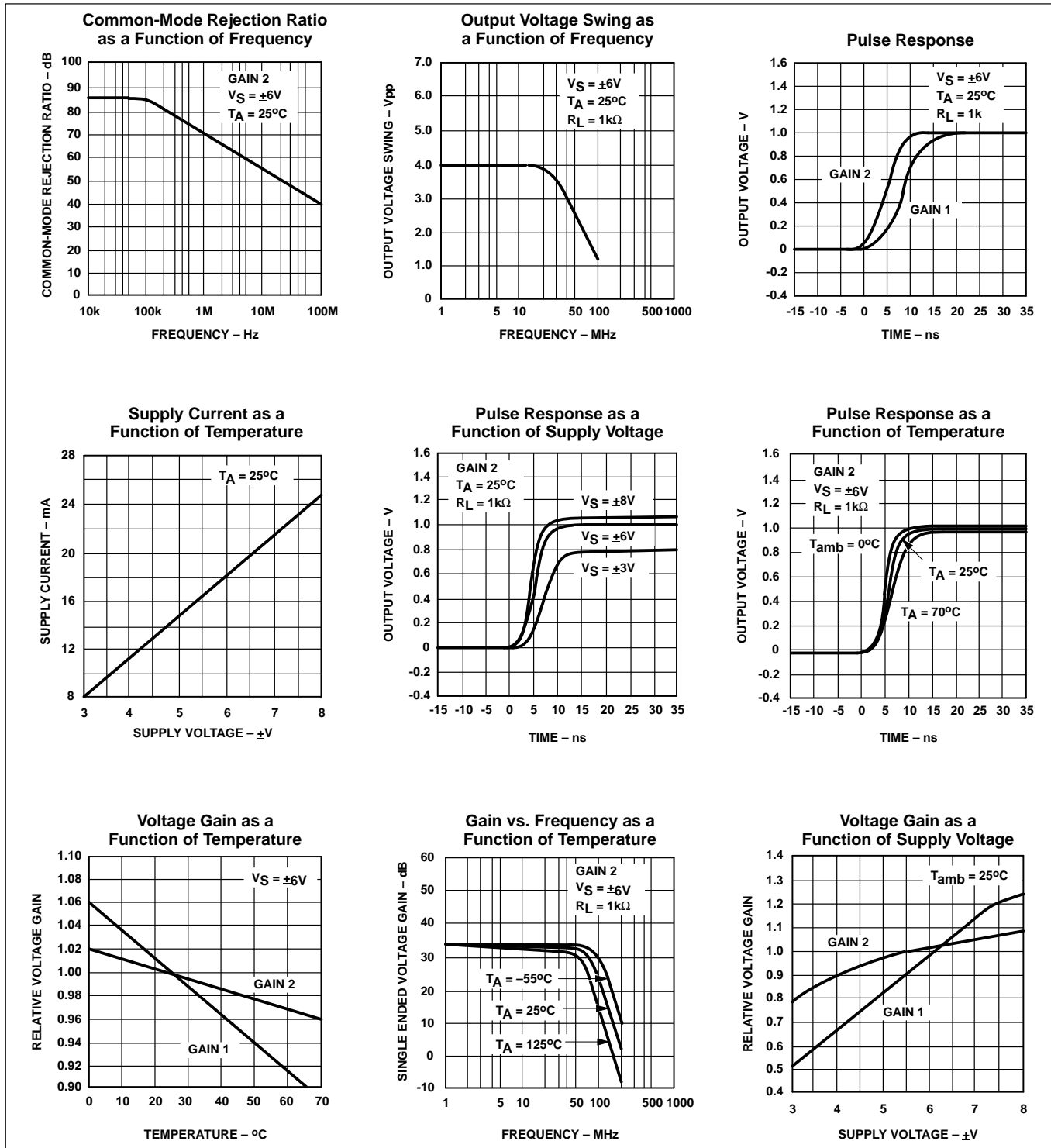

Video amplifier

NE592

TYPICAL PERFORMANCE CHARACTERISTICS (Continued)

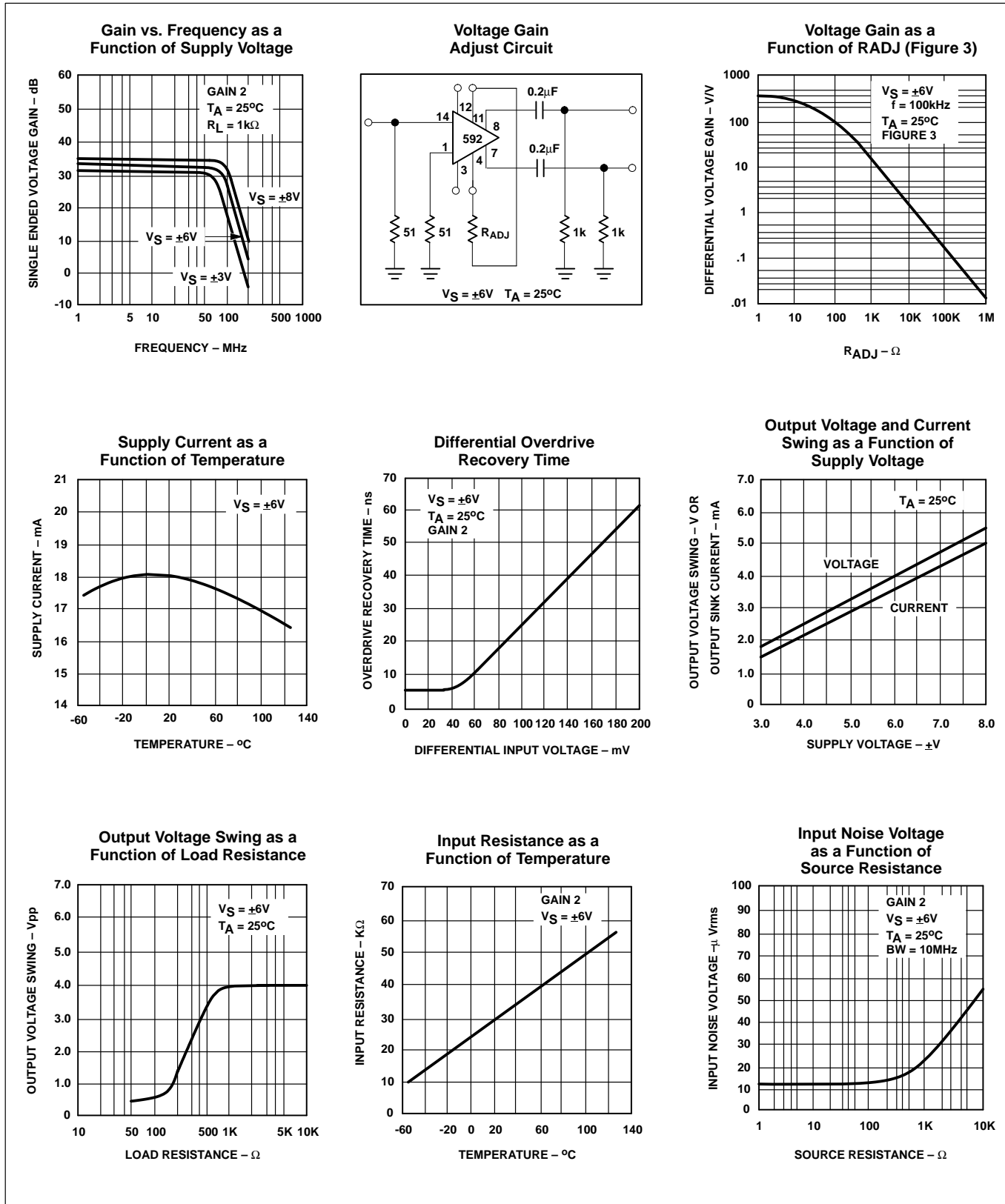

Video amplifier

NE592

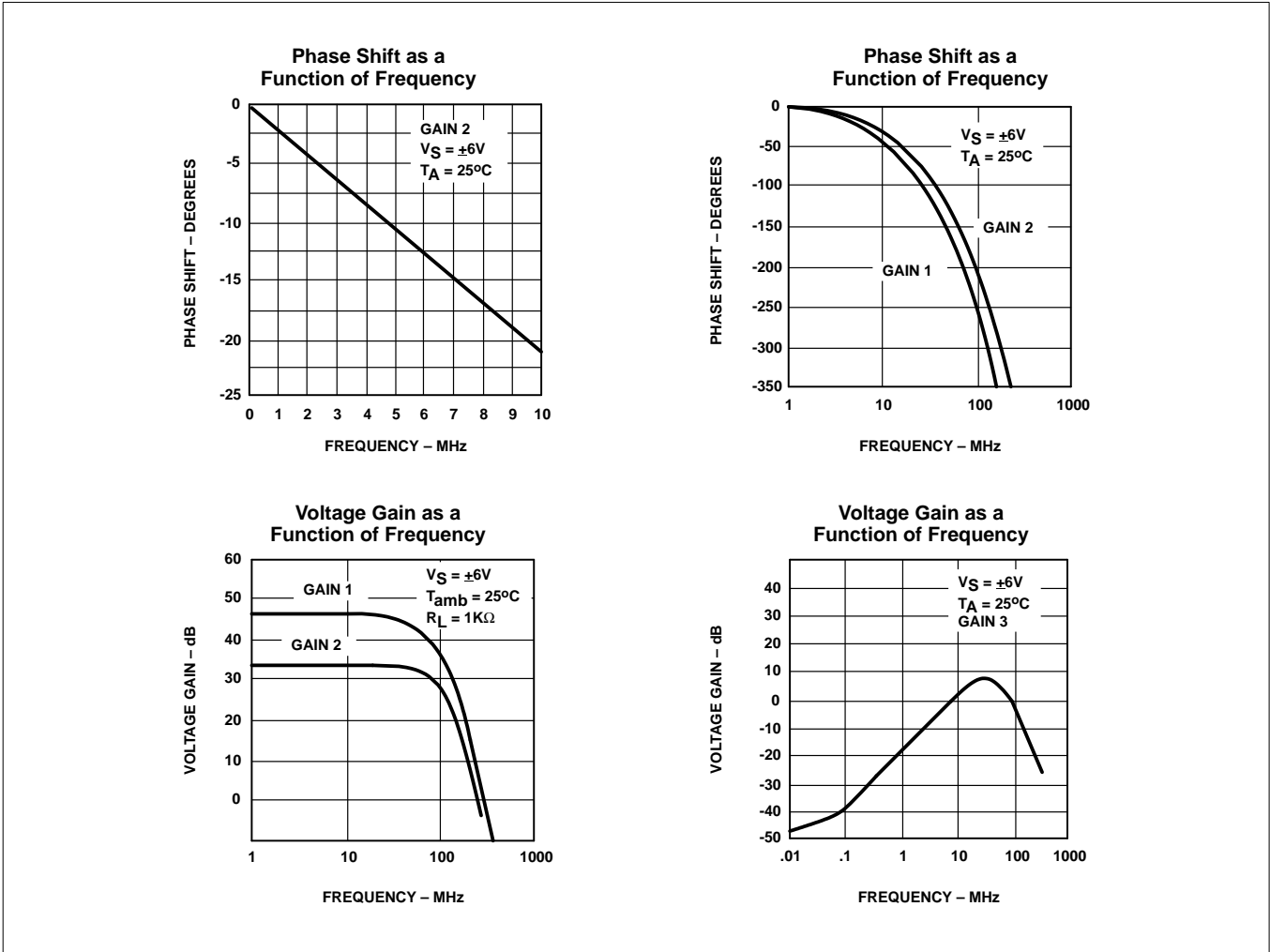

TEST CIRCUITS TA = 25°C, unless otherwise specified.

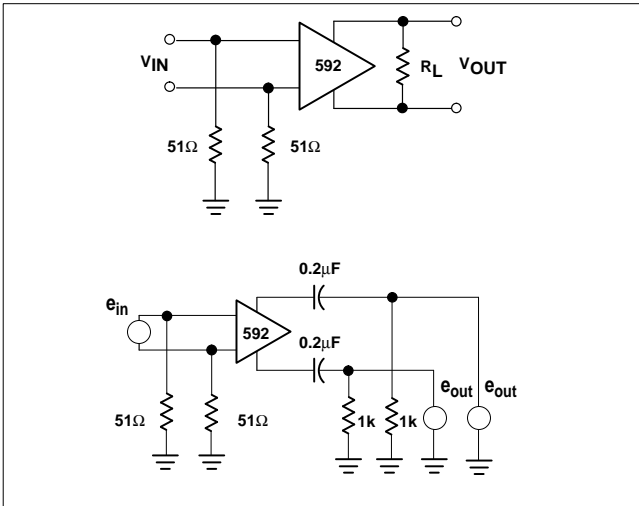

Video amplifier

NE592

TYPICAL APPLICATIONS

NOTE:

$$\frac{V_0(s)}{V_1(s)} \approx \frac{1.4 \cdot 10^4}{Z(s) + 2r_e}$$

$$\approx \frac{1.4 \cdot 10^4}{Z(s) + 32}$$

Basic Configuration

Differentiation with High Common-Mode Noise Rejection

NOTE:
For frequency $F_1 \ll 1/2 \pi (32) C$

$$V_0 = 1.4 \times 10^4 C \frac{dV_i}{dt}$$

Disc/Tape Phase-Modulated Readback Systems

AMPLITUDE: 1-10 mV p-p
FREQUENCY: 1-4 MHz

FILTER NETWORKS

Z NETWORK	FILTER TYPE	V ₀ (s) TRANSFER V ₁ (s) FUNCTION
	LOW PASS	$\frac{1.4 \times 10^4}{L} \left[\frac{1}{s + R/L} \right]$
	HIGH PASS	$\frac{1.4 \times 10^4}{R} \left[\frac{s}{s + 1/RC} \right]$
	BAND PASS	$\frac{1.4 \times 10^4}{L} \left[\frac{s}{s^2 + R/Ls + 1/LC} \right]$
	BAND REJECT	$\frac{1.4 \times 10^4}{R} \left[\frac{s^2 + 1/LC}{s^2 + 1/LC + s/RC} \right]$

NOTES:
 In the networks above, the R value used is assumed to include 2r_e, or approximately 32Ω.
 S = jω
 ω = 2πf