

# DATA SHEET

## **TEA1610P; TEA1610T** Zero-voltage-switching resonant converter controller

Product specification  
File under Integrated Circuits, IC11

2001 Apr 25

# Zero-voltage-switching resonant converter controller

## TEA1610P; TEA1610T

### FEATURES

- Integrated high voltage level-shift function
- Integrated high voltage bootstrap diode
- Transconductance error amplifier for ultra high-ohmic regulation feedback
- Latched shut-down circuit for overcurrent and overvoltage protection
- Low start-up current (green function)
- Adjustable minimum and maximum frequencies
- Adjustable dead time
- Undervoltage lockout.

### GENERAL DESCRIPTION

The TEA1610 is a monolithic integrated circuit implemented in a high-voltage DMOS process. The circuit is a high voltage controller for a zero-voltage switching resonant converter. The IC provides the drive function for two discrete power MOSFETs in a half-bridge configuration. It also includes a level-shift circuit, an oscillator with accurately-programmable frequency range, a latched shut-down function and a transconductance error amplifier.

To guarantee an accurate 50% switching duty factor, the oscillator signal passes through a divide-by-two flip-flop before being fed to the output drivers.

The circuit is very flexible and enables a broad range of applications for different mains voltages.

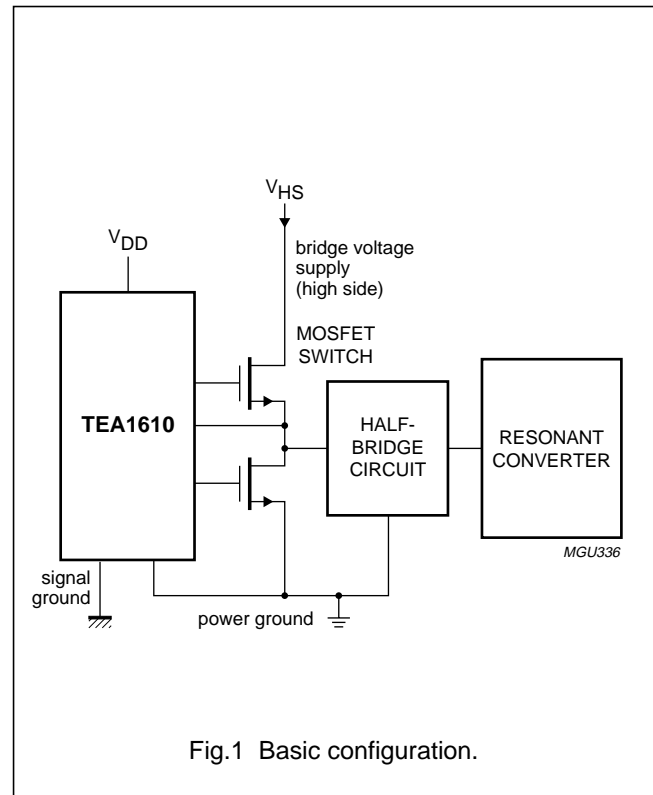

Fig.1 Basic configuration.

### APPLICATIONS

- TV and monitor power supplies
- High voltage power supplies.

### QUICK REFERENCE DATA

SYMBOL	PARAMETER	CONDITIONS	MAX.	UNIT
$V_{HS}$	bridge voltage supply (high side)		600	V
$I_{GH(source)}$ ; $I_{GL(source)}$	gate driver source current		-225	mA
$I_{GH(sink)}$ ; $I_{GL(sink)}$	gate driver sink current		300	mA
$f_{bridge(max)}$	maximum bridge frequency	$C_f = 100 \text{ pF}$ (see Fig.10)	550	kHz
$V_{I(CM)}$	error amplifier common mode input voltage		2.5	V

### ORDERING INFORMATION

TYPE NUMBER	PACKAGE		
	NAME	DESCRIPTION	VERSION
TEA1610P	DIP16	plastic dual in-line package; 16 leads (300 mil); long body	SOT38-1
TEA1610T	SO16	plastic small outline package; 16 leads; body width 3.9 mm; low stand-off height	SOT109-2

Zero-voltage-switching resonant converter controller

TEA1610P; TEA1610T

BLOCK DIAGRAM

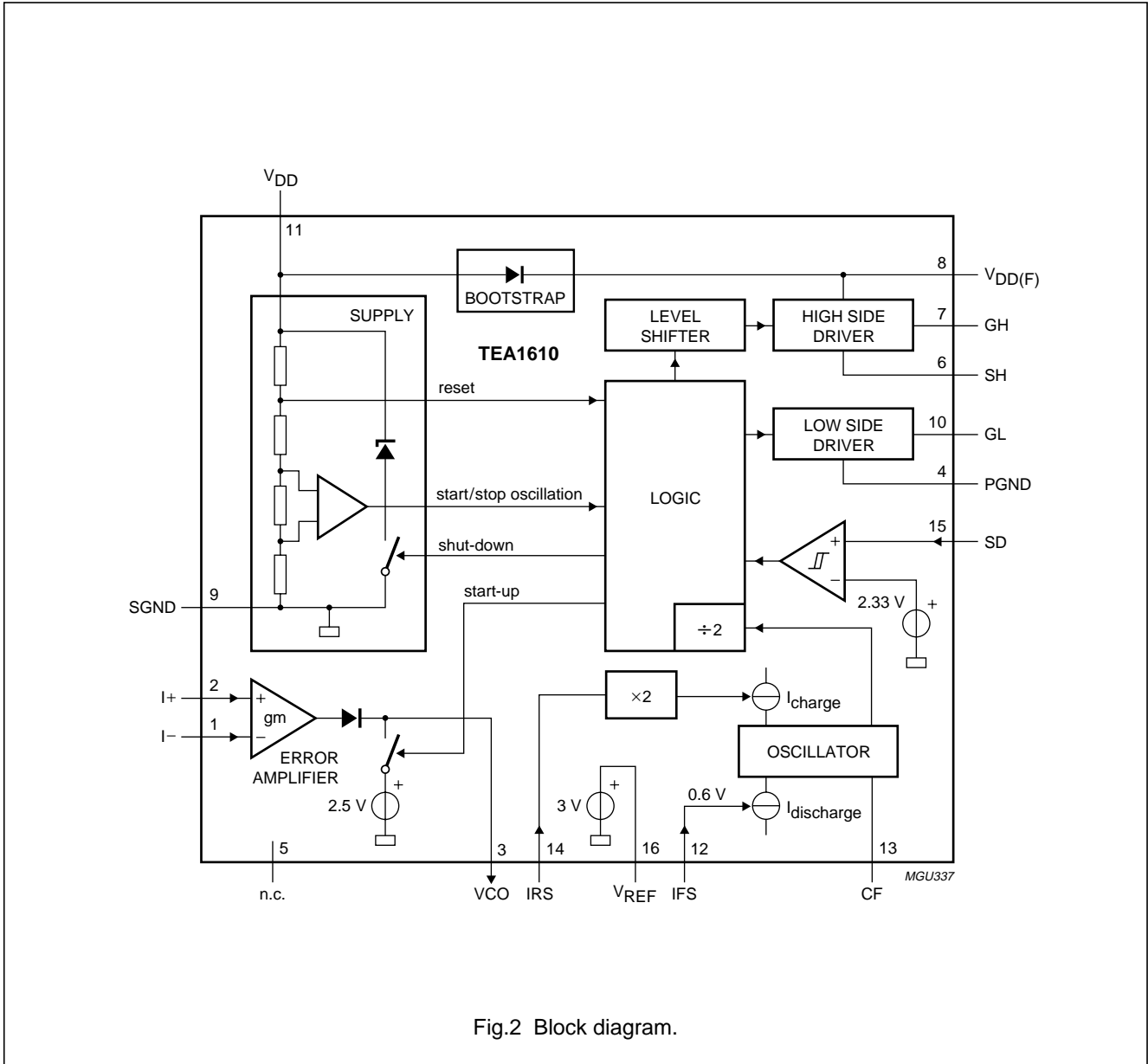

# Zero-voltage-switching resonant converter controller

## TEA1610P; TEA1610T

### PINNING

SYMBOL	PIN	DESCRIPTION
I-	1	error amplifier inverting input
I+	2	error amplifier non-inverting input
VCO	3	error amplifier output
PGND	4	power ground
n.c.	5	not connected (high voltage spacer)
SH	6	high side switch source
GH	7	gate of the high side switch
V <sub>DD(F)</sub>	8	floating supply voltage for the high side driver
SGND	9	signal ground
GL	10	gate of the low side switch
V <sub>DD</sub>	11	supply voltage
IFS	12	oscillator discharge current input
CF	13	oscillator capacitor
IRS	14	oscillator charge current input
SD	15	shut-down input
V <sub>REF</sub>	16	reference voltage

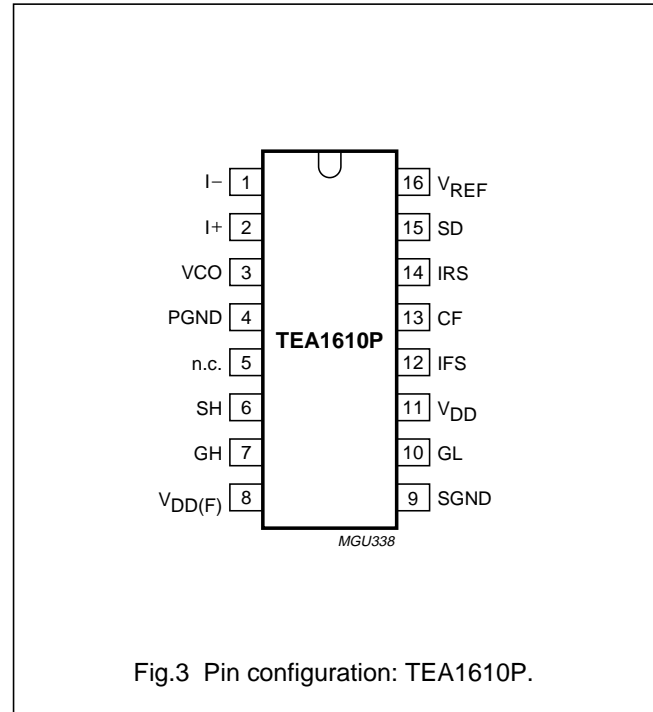

Fig.3 Pin configuration: TEA1610P.

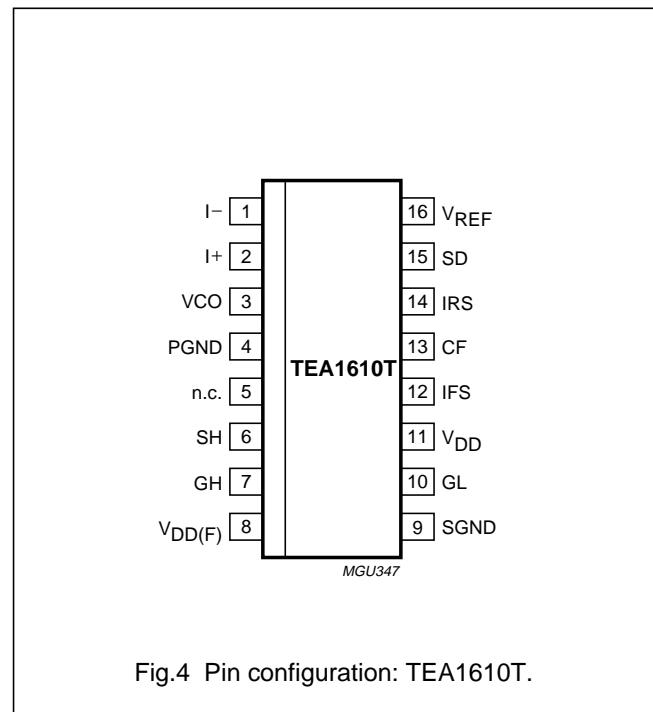

Fig.4 Pin configuration: TEA1610T.

# Zero-voltage-switching resonant converter controller

## TEA1610P; TEA1610T

### FUNCTIONAL DESCRIPTION

#### Start-up

When the applied voltage at  $V_{DD}$  reaches  $V_{DD(initial)}$  (see Fig.5), the low side power switch is turned-on while the high side power switch remains in the non-conducting state. This start-up output state guarantees the initial charging of the bootstrap capacitor ( $C_{boot}$ ) used for the floating supply of the high side driver.

During start-up, the voltage on the frequency capacitor ( $C_f$ ) is zero and defines the start-up state. The output voltage of the error amplifier is kept constant (typ. 2.5 V) and switching starts at about 80% of the maximum frequency at the moment pin  $V_{DD}$  reaches the start level.

The start-up state is maintained until  $V_{DD}$  reaches the start level (13.5 V), the oscillator is activated and the converter starts operating.

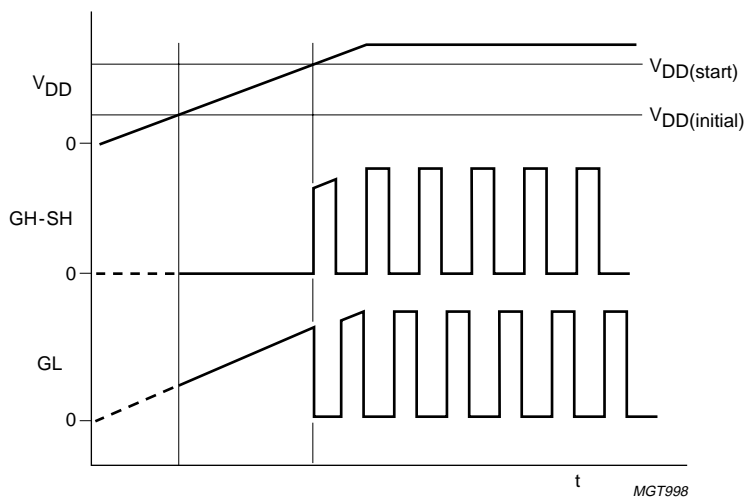

Fig.5 Start-up.

# Zero-voltage-switching resonant converter controller

## TEA1610P; TEA1610T

### Oscillator

The internal oscillator is a current-controlled oscillator that generates a sawtooth output. The frequency of the sawtooth is determined by the external capacitor  $C_f$  and the currents flowing into the IFS and IRS pins.

The minimum frequency and the dead time are set by the capacitor  $C_f$  and resistors  $R_{f(min)}$  and  $R_{dt}$ . The maximum frequency is set by resistor  $R_{\Delta f}$  (see Fig.10). The oscillator frequency is exactly twice the bridge frequency to achieve an accurate 50% duty factor. An overview of the oscillator and driver signals is given in Fig.6.

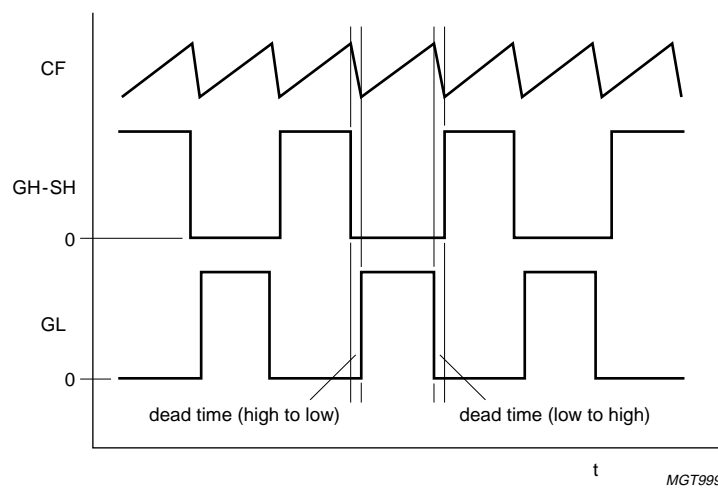

Fig.6 Oscillator and driver signals.

# Zero-voltage-switching resonant converter controller

## TEA1610P; TEA1610T

### Dead time resistor $R_{dt}$ (see Fig.10)

The dead time resistor  $R_{dt}$  is connected between the 3 V reference pin ( $V_{REF}$ ) and the IFS current input pin. The voltage on the IFS pin is kept constant at a temperature independant value of 0.6 V. The current that flows into the IFS pin is determined by the value of resistor  $R_{dt}$  and the 2.4 V voltage drop across this resistor. The IFS input current equals the discharge current of capacitor  $C_f$  and determines the falling slope of the oscillator.

The falling slope time is used to create a dead time ( $t_{dt}$ ) between two successive switching actions of the half-bridge switches:

$$I_{IFS} = \frac{2.4 \text{ V}}{R_{dt}}$$

$$t_{dt} = \frac{C_f \times \Delta V_{Cf}}{I_{IFS}}$$

$$t_{IFS} = t_{dt}$$

### Minimum frequency resistor (see Fig.10)

The  $R_{f(min)}$  resistor is connected between the  $V_{REF}$  pin (3 V reference voltage) and the IRS current input (held at a temperature independant voltage level of 0.6 V). The charge current of the capacitor  $C_f$  is twice the current flowing into the IRS pin.

The  $R_{f(min)}$  resistor has a voltage drop of 2.4 V and its resistance defines the minimum charge current (rising slope) of the  $C_f$  capacitor if the control current is zero. The minimum frequency is defined by this minimum charge current ( $I_{IRS1}$ ) and the discharge current:

$$I_{IRS1} = \frac{2.4 \text{ V}}{R_{f(min)}}$$

$$t_{IRS1} = \frac{C_f \times \Delta V_{Cf}}{2 \times I_{IRS1}}$$

$$f_{min} = \frac{1}{t_{dt} + t_{IRS1}}$$

### Maximum frequency resistor

The output voltage is regulated by changing the frequency of the half-bridge converter. The maximum frequency is determined by the  $R_{\Delta f}$  resistor which is connected between the error amplifier output VCO and the oscillator current input pin IRS. The current that flows through the  $R_{\Delta f}$  resistor ( $I_{IRS2}$ ) is added to the current flowing through the

$R_{f(min)}$  resistor. As a result, the charge current  $I_{CF}$  increases and the oscillation frequency increases. As the falling slope of the oscillator is constant, the relationship between the output frequency and the charge current is not a linear function (see Figs 7 and 9):

$$I_{IRS2} = \frac{V_{VCO} - 0.6}{R_{\Delta f}}$$

$$t_{IRS2} = \frac{C_f \times \Delta V_{Cf}}{I_{IRS1} + I_{IRS2}} \times 2$$

The maximum output voltage of the error amplifier and the value of  $R_{\Delta f}$  determine the maximum frequency:

$$I_{IRS2(max)} = \frac{V_{VCO(max)} - 0.6}{R_{\Delta f}}$$

$$t_{IRS(min)} = \frac{C_f \times \Delta V_{Cf}}{I_{IRS1} + I_{IRS2(max)}} \times 2$$

$$f_{max} = \frac{1}{T_{osc}}$$

$$T_{osc} = t_{IRS(min)} + t_{IFS}$$

Bridge frequency accuracy is optimum in the low frequency region. At higher frequencies both the dead time and the oscillator frequency show a decay.

The frequency of the oscillator depends on the value of capacitor  $C_f$ , the peak-to-peak voltage swing  $V_{Cf}$  and the charge and discharge currents. However, at higher frequencies the accuracy decreases due to delays in the circuit.

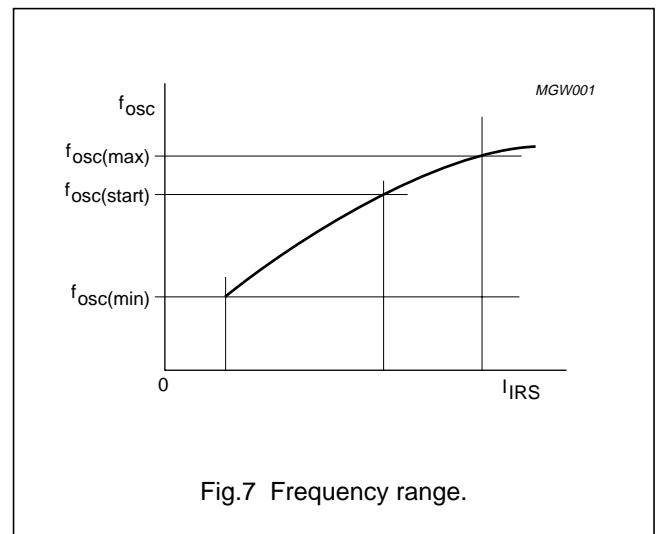

Fig.7 Frequency range.

# Zero-voltage-switching resonant converter controller

## TEA1610P; TEA1610T

### Error amplifier

The error amplifier is a transconductance amplifier. Thus the output current at pin VCO is determined by the amplifier transconductance and the differential voltage on input pins I+ and I-. The output current  $I_{VCO}$  is fed to the IRS input of the current-controlled oscillator.

The source capability of the error amplifier increases current in the IRS pin when the differential input voltage is positive. Therefore the minimum current is determined by resistor  $R_{f(min)}$  and the minimum frequency setting is independent of the characteristics of the error amplifier.

The error amplifier has a maximum output current of 0.5 mA for an output voltage up to 2.5 V. If the source current decreases, the oscillator frequency also decreases resulting in a higher regulated output voltage.

During start-up, the output voltage of the amplifier is held at a constant value of 2.5 V. This voltage level defines, together with resistor  $R_{\Delta f}$ , the initial switching frequency of the TEA1610 after start-up.

### Shut-down

The shut-down input (SD) has an accurate threshold level of 2.33 V. When the voltage on input SD reaches 2.33 V, both power switches immediately switch off and the TEA1610 enters shut-down mode.

During shut-down mode, pin  $V_{DD}$  is clamped by an internal Zener diode at 12.0 V with 1 mA input current. This clamp prevents  $V_{DD}$  rising above the rating of 14 V due to low supply current to the TEA1610 in shut-down mode.

When the TEA1610 is in the shut-down mode, it can be activated again only by lowering  $V_{DD}$  below the  $V_{DD}$  reset level (5.3 V typical). The shut-down latch is then reset and a new start-up cycle can commence (see Fig.8).

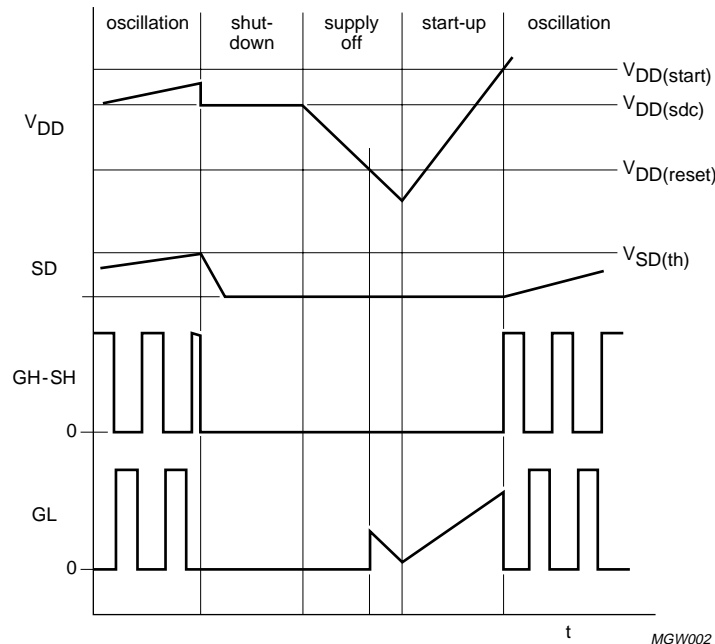

Fig.8 Shut-down.



## Zero-voltage-switching resonant converter controller

TEA1610P; TEA1610T

### LIMITING VALUES

In accordance with the Absolute Maximum Rating System (IEC 60134); all voltages are referred to the ground pins which must be interconnected externally; positive currents flow into the IC.

SYMBOL	PARAMETER	CONDITIONS	MIN.	MAX.	UNIT
<b>Voltages</b>					
$V_{SH}$	high side driver voltage		0	600	V
$V_{DD}$	supply voltage		0	14	V
$V_{I+}$	amplifier non-inverting input voltage		0	5	V
$V_{I-}$	amplifier inverting input voltage		0	5	V
$V_{SD}$	shut-down input voltage		0	5	V
<b>Currents</b>					
$I_{IFS}$	oscillator falling slope input current		–	1	mA
$I_{IRS}$	oscillator rising slope input current		–	1	mA
$I_{REF}$	$V_{REF}$ source current		–	–2	mA
<b>Power and temperature</b>					
$P_{tot}$	total power dissipation	$T_{amb} < 70\text{ °C}$	–	0.8	W
$T_{amb}$	ambient temperature	operating	–25	+70	°C
$T_{stg}$	storage temperature		–25	+150	°C
<b>Handling</b>					
$V_{ES}$	electrostatic handling voltage	note 1	–	2000	V
		note 2	–	200	V

### Notes

- Human body model class 2: equivalent to discharging a 100 pF capacitor through a 1.5 k $\Omega$  series resistor.
- Machine model class 2: equivalent to discharging a 200 pF capacitor through a 0.75  $\mu$ H coil and 10  $\Omega$  resistor.

### THERMAL CHARACTERISTICS

SYMBOL	PARAMETER	CONDITIONS	VALUE	UNIT
$R_{th(j-a)}$	thermal resistance from junction to ambient	in free air	100	K/W
$R_{th(j-pin)}$	thermal resistance from junction to pin		50	K/W

### QUALITY SPECIFICATION

In accordance with “SNW-FQ-611-E”.

# Zero-voltage-switching resonant converter controller

TEA1610P; TEA1610T

## CHARACTERISTICS

All voltages are referred to the ground pins which must be connected externally; positive currents flow into the IC;  $V_{DD} = 13\text{ V}$  and  $T_{amb} = 25\text{ °C}$ ; tested in the circuit of Fig.10; unless otherwise specified.

SYMBOL	PARAMETER	CONDITIONS	MIN.	TYP.	MAX.	UNIT
<b>High voltage pins <math>V_{DD(F)}</math>, GH and SH</b>						
$I_L$	leakage current	$V_{DD(F)}$ , $V_{GH}$ and $V_{SH} = 600\text{ V}$	–	–	30	$\mu\text{A}$
<b>Supply pin <math>V_{DD}</math></b>						
$V_{DD(\text{initial})}$	supply voltage for defined driver output	low side on; high side off	–	4	5	V
$V_{DD(\text{start})}$	start oscillator voltage		12.9	13.4	13.9	V
$V_{DD(\text{stop})}$	stop oscillator voltage		9.0	9.4	9.8	V
$V_{DD(\text{hys})}$	start-stop hysteresis voltage		3.8	4.0	4.2	V
$V_{DD(\text{sd})}$	shut-down clamp voltage	low side off; high side off; $I_{DD} = 1\text{ mA}$	11.0	12.0	13.0	V
$V_{DD(\text{reset})}$	reset voltage		4.5	5.3	6.0	V
$I_{DD}$	supply current:					
	start-up	low side on; high side off	130	180	220	$\mu\text{A}$
	operating	$C_f = 100\text{ pF}$ ; $I_{IFS} = 0.5\text{ mA}$ ; $I_{IRS} = 50\text{ }\mu\text{A}$ ; $C_o = 200\text{ pF}$ ; note 1	–	2.4	–	mA
	shut-down	low side off; high side off; $V_{DD} = 9\text{ V}$	–	130	180	$\mu\text{A}$
<b>Reference voltage pin <math>V_{REF}</math></b>						
$V_{REF}$	reference voltage	$I_{REF} = 0\text{ mA}$	2.9	3.0	3.1	V
$I_{REF}$	current capability	source only	–1.0	–	–	mA
$Z_{o(VREF)}$	output impedance	$I_{REF} = -1\text{ mA}$	–	5.0	–	$\Omega$
$\frac{\Delta V_{REF}}{\Delta T}$	temperature coefficient	$I_{REF} = 0$ ; $T_j = 25\text{ to }150\text{ °C}$	–	–0.3	–	mV/K
<b>Current controlled oscillator pins IRS, IFS, CF</b>						
$I_{CF(\text{ch})(\text{min})}$	minimum CF charge current	$I_{IRS} = 15\text{ }\mu\text{A}$ ; $V_{CF} = 2\text{ V}$	28	30	32	$\mu\text{A}$
$I_{CF(\text{ch})(\text{max})}$	maximum CF charge current	$I_{IRS} = 200\text{ }\mu\text{A}$ ; $V_{CF} = 2\text{ V}$	340	380	420	$\mu\text{A}$
$V_{IRS}$	pin IRS voltage	$I_{IRS} = 200\text{ }\mu\text{A}$	570	600	630	mV
$I_{CF(\text{dis})(\text{min})}$	minimum CF discharge current	$I_{IRS} = 50\text{ }\mu\text{A}$ ; $V_{CF} = 2\text{ V}$	47	50	53	$\mu\text{A}$
$I_{CF(\text{dis})(\text{max})}$	maximum CF discharge current	$I_{IFS} = 1\text{ mA}$ ; $V_{CF} = 2\text{ V}$	0.93	0.98	1.03	mA
$V_{IFS}$	pin IFS voltage	$I_{IFS} = 1\text{ mA}$	570	600	630	mV
$f_{\text{bridge}(\text{min})}$	minimum bridge frequency (for stable operation)	$C_f = 100\text{ pF}$ ; $I_{IFS} = 0.5\text{ mA}$ ; $I_{IRS} = 50\text{ }\mu\text{A}$ ; $f_{\text{bridge}} = \frac{f_{\text{osc}}}{2}$	188	200	212	kHz
$f_{\text{bridge}(\text{max})}$	maximum bridge frequency	$C_f = 100\text{ pF}$ ; $I_{IFS} = 1\text{ mA}$ ; $I_{IRS} = 200\text{ }\mu\text{A}$ ; $f_{\text{bridge}} = \frac{f_{\text{osc}}}{2}$ ; note 2	450	500	550	kHz

Zero-voltage-switching  
resonant converter controller

## TEA1610P; TEA1610T

SYMBOL	PARAMETER	CONDITIONS	MIN.	TYP.	MAX.	UNIT
$V_{CF(L)}$	CF trip level LOW	DC level	–	1.27	–	V
$V_{CF(H)}$	CF trip level HIGH	DC level	–	3.0	–	V
$V_{Cf(p-p)}$	$C_f$ voltage (peak-to-peak value)		1.63	1.73	1.83	V
$t_{dt}$	dead time	$C_f = 100 \text{ pF}$ ; $I_{IFS} = 0.5 \text{ mA}$ ; $I_{IRS} = 50 \text{ }\mu\text{A}$	0.37	0.40	0.43	$\mu\text{s}$
<b>Output drivers</b>						
$I_{GH(\text{source})}$	high side output source current	$V_{DD(F)} = 13 \text{ V}$ ; $V_{SH} = 0$ ; $V_{GH} = 0$	–135	–180	–225	mA
$I_{GH(\text{sink})}$	high side output sink current	$V_{DD(F)} = 13 \text{ V}$ ; $V_{SH} = 0$ ; $V_{GH} = 13 \text{ V}$	–	300	–	mA
$I_{GL(\text{source})}$	low side output source current	$V_{GL} = 0$	–135	–180	–225	mA
$I_{GL(\text{sink})}$	low side output sink current	$V_{GL} = 14 \text{ V}$	–	300	–	mA
$V_{GH(H)}$	high side output voltage HIGH	$V_{DD(F)} = 13 \text{ V}$ ; $V_{SH} = 0$ ; $I_{GH} = 10 \text{ mA}$	10.8	12	–	V
$V_{GH(L)}$	high side output voltage LOW	$V_{DD(F)} = 13 \text{ V}$ ; $V_{SH} = 0$ ; $I_{GH} = 10 \text{ mA}$	–	0.2	0.5	V
$V_{GL(H)}$	low side output voltage HIGH	$I_{GL} = 10 \text{ mA}$	10.8	12	–	V
$V_{GL(L)}$	low side output voltage LOW	$I_{GL} = 10 \text{ mA}$	–	0.2	0.5	V
$V_{d(\text{boot})}$	bootstrap diode voltage drop	$I = 5 \text{ mA}$	1.5	1.8	2.1	V
<b>Shut-down input pin SD</b>						
$I_{SD}$	input current	$V_{SD} = 2.33 \text{ V}$	0	0.2	0.5	$\mu\text{A}$
$V_{SD(\text{th})}$	threshold level		2.26	2.33	2.40	V
<b>Error amplifier pins I+, I–, VCO</b>						
$I_{I(\text{CM})}$	common mode input current	$V_{I(\text{CM})} = 1 \text{ V}$	–	–0.1	–0.5	$\mu\text{A}$
$V_{I(\text{CM})}$	common mode input voltage		–	–	2.5	V
$V_{I(\text{offset})}$	input offset voltage	$V_{I(\text{CM})} = 1 \text{ V}$ ; $I_{VCO} = -10 \text{ mA}$	–2	0	+2	mV
$g_m$	transconductance	$V_{I(\text{CM})} = 1 \text{ V}$ ; source only	–	330	–	$\mu\text{A/mV}$
$A_o$	open loop gain	$R_L = 10 \text{ k}\Omega$ to GND; $V_{I(\text{CM})} = 1 \text{ V}$	–	70	–	dB
GB	gain bandwidth product	$R_L = 10 \text{ k}\Omega$ to GND; $V_{I(\text{CM})} = 1 \text{ V}$	–	5	–	MHz
$V_{VCO(\text{max})}$	maximum output voltage	operating; $R_L = 10 \text{ k}\Omega$ to GND	3.2	3.6	4.0	V
$I_{VCO(\text{max})}$	maximum output current	operating; $V_{VCO} = 1 \text{ V}$	–0.4	–0.5	–0.6	mA
$V_{VCO(\text{start})}$	output voltage during start-up	$I_{VCO} = 0.3 \text{ mA}$	2.30	2.50	2.70	V

**Notes**

- Supply current  $I_{DD}$  will increase with increasing bridge frequency to drive the capacitive load of two MOSFETs. Typical MOSFETs for the TEA1610 application are 8N50 (Philips type PHX80N50E,  $Q_{g(\text{tot})} = 55 \text{ nC typ.}$ ) and these will increase the supply current at 150 kHz according to the following formula:  

$$\Delta I_{DD} = 2 \times Q_{g(\text{tot})} \times f_{\text{bridge}} = 2 \times 55 \text{ nC} \times 150 \text{ kHz} = 16.5 \text{ mA.}$$
- The frequency of the oscillator depends on the value of capacitor  $C_f$ , the peak-to-peak voltage swing  $V_{CF}$  and the charge/discharge currents  $I_{CF(\text{ch})}$  and  $I_{CF(\text{dis})}$ .

# Zero-voltage-switching resonant converter controller

## TEA1610P; TEA1610T

### APPLICATION INFORMATION

An application example of a zero-voltage-switching resonant converter application using TEA1610 is shown in Fig.10. In the off-mode the  $V_{DD}$  voltage is pulled below the stop level of 9.4 V by the 7.5 V Zener diode and the half-bridge is not driven. In the on-mode the TEA1610 starts-up with a high-ohmic bleeder resistor. After passing the level for start of oscillation, the TEA1610 is in normal operating mode and consumes the normal supply current delivered by the 12 V supply. The dead time is set by  $R_{dt}$  and  $C_f$ . The minimum frequency is adjusted by  $R_{f(min)}$  and the frequency range is set by  $R_{\Delta f}$ . The output voltage is adjusted with a potentiometer connected to the inverting input of the error amplifier and is regulated via a feedback circuit. The shut-down input is used for overvoltage protection. To prevent interference, filter capacitors can be added on pins IFS, IRS and  $V_{REF}$ . The maximum value of each filter capacitor is 100 pF.

Practical values of the application example are given in Fig.9 in which the measured oscillator frequency with capacitor  $C_f = 220$  pF is shown as a function of the charge current  $I_{IRS}$ . Note that the slope of the measured frequency differs from the theoretical frequency (frequency set) calculated as described in Section "Maximum frequency resistor".

The measured dead time is directly related to charge current (total current flowing into pin IRS) and therefore to oscillator frequency.

The measured frequency graph can be used to determine the required  $R_{\Delta f}$  resistor for a certain maximum frequency in an application with the same value of capacitor  $C_f$ .

More application information can be found in application note "AN99011".

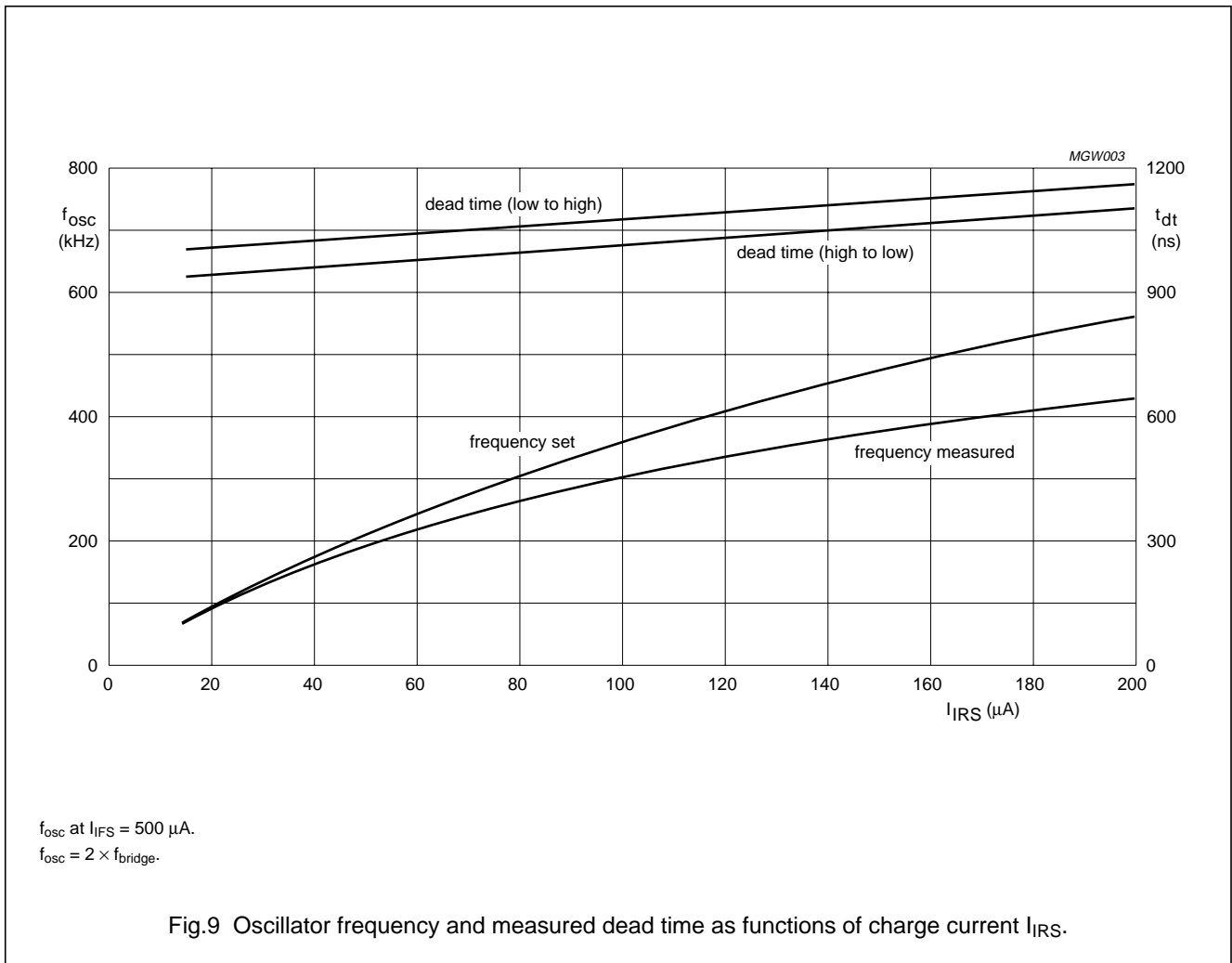

Zero-voltage-switching resonant converter controller

TEA1610P; TEA1610T

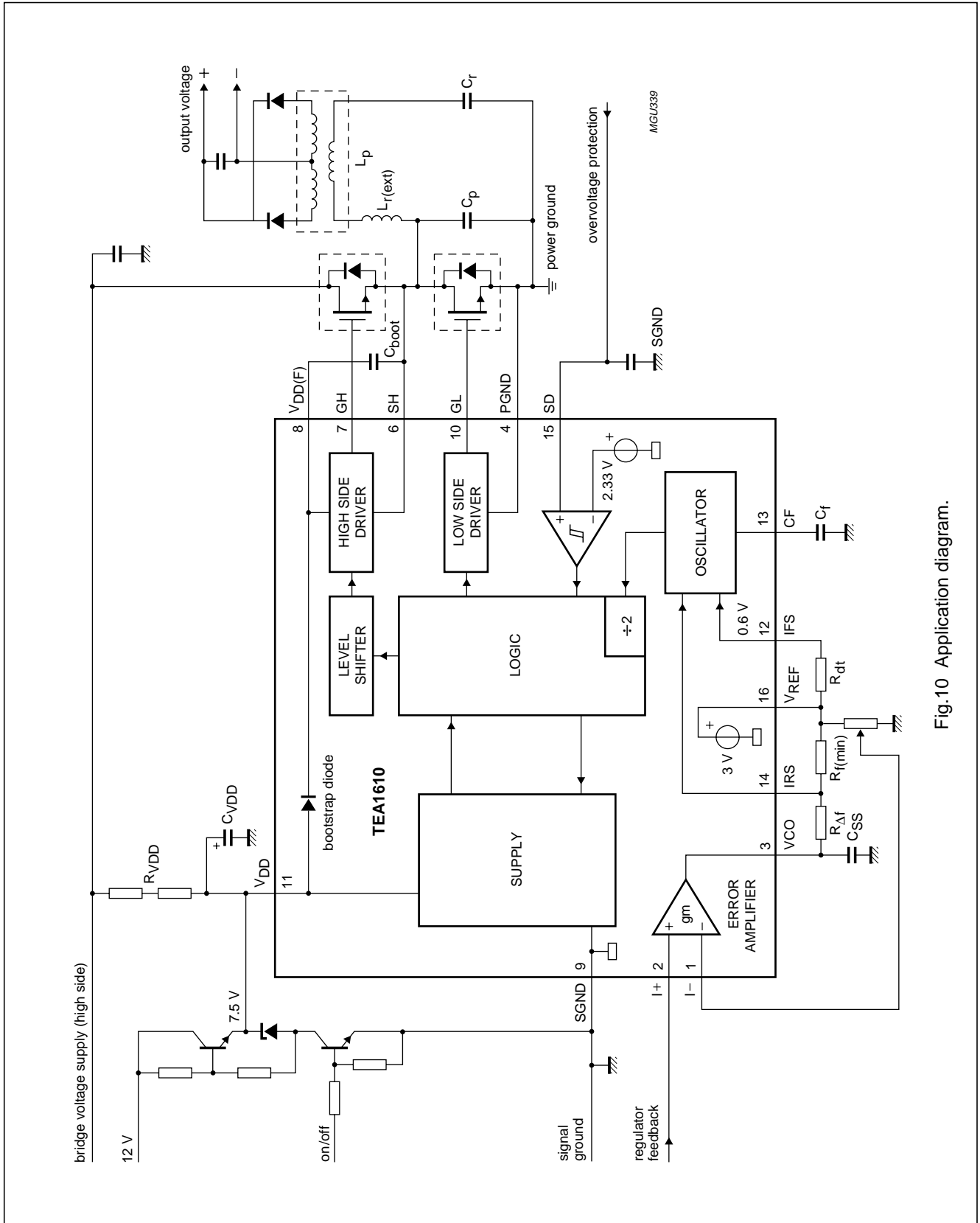

Fig.10 Application diagram.

Zero-voltage-switching  
resonant converter controller

TEA1610P; TEA1610T

PACKAGE OUTLINES

DIP16: plastic dual in-line package; 16 leads (300 mil); long body

SOT38-1

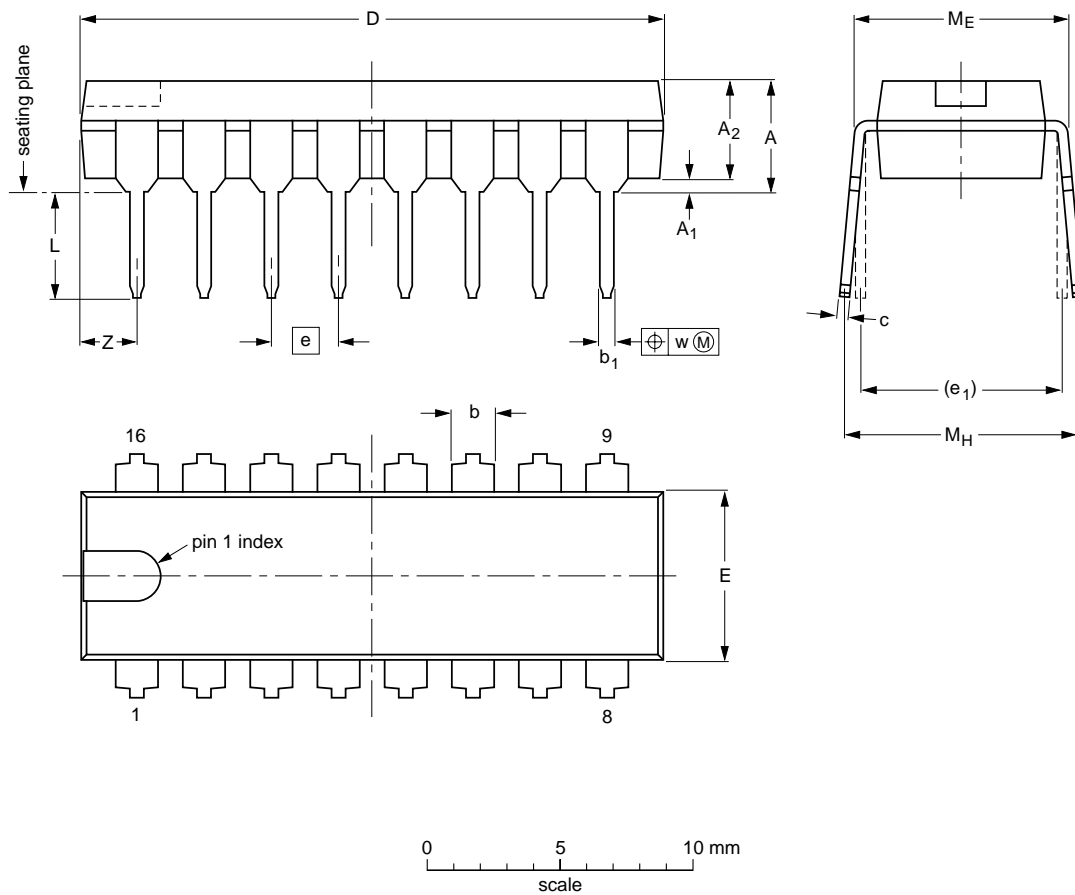

DIMENSIONS (inch dimensions are derived from the original mm dimensions)

UNIT	A max.	A <sub>1</sub> min.	A <sub>2</sub> max.	b	b <sub>1</sub>	c	D <sup>(1)</sup>	E <sup>(1)</sup>	e	e <sub>1</sub>	L	M <sub>E</sub>	M <sub>H</sub>	w	Z <sup>(1)</sup> max.
mm	4.7	0.51	3.7	1.40 1.14	0.53 0.38	0.32 0.23	21.8 21.4	6.48 6.20	2.54	7.62	3.9 3.4	8.25 7.80	9.5 8.3	0.254	2.2
inches	0.19	0.020	0.15	0.055 0.045	0.021 0.015	0.013 0.009	0.86 0.84	0.26 0.24	0.10	0.30	0.15 0.13	0.32 0.31	0.37 0.33	0.01	0.087

Note

1. Plastic or metal protrusions of 0.25 mm maximum per side are not included.

OUTLINE VERSION	REFERENCES				EUROPEAN PROJECTION	ISSUE DATE
	IEC	JEDEC	EIAJ			
SOT38-1	050G09	MO-001	SC-503-16			95-01-19 99-12-27

Zero-voltage-switching  
resonant converter controller

TEA1610P; TEA1610T

SO16: plastic small outline package; 16 leads; body width 3.9 mm; low stand-off height

SOT109-2

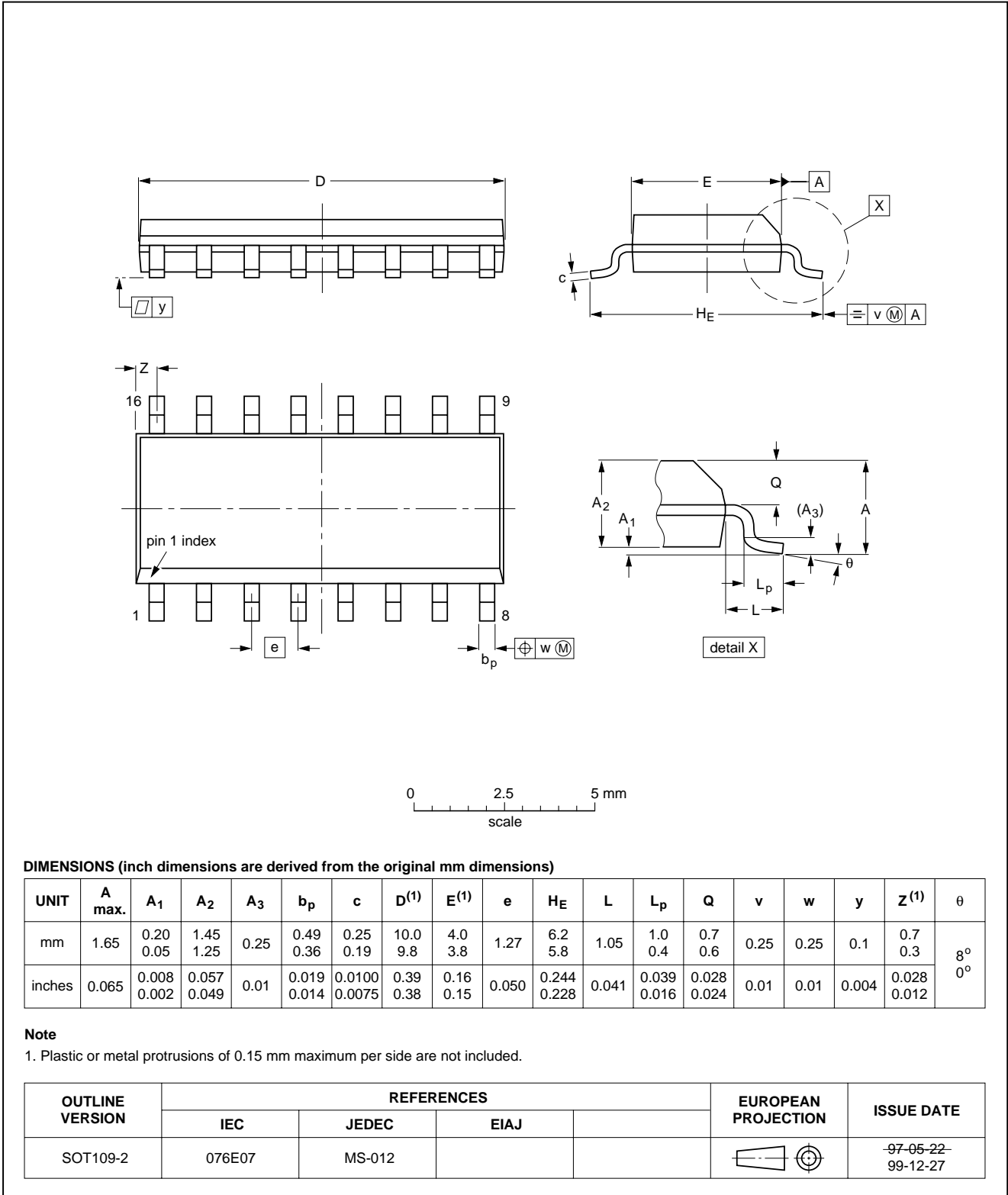

## Zero-voltage-switching resonant converter controller

## TEA1610P; TEA1610T

### SOLDERING

#### Introduction

This text gives a very brief insight to a complex technology. A more in-depth account of soldering ICs can be found in our *"Data Handbook IC26; Integrated Circuit Packages"* (document order number 9398 652 90011).

There is no soldering method that is ideal for all IC packages. Wave soldering is often preferred when through-hole and surface mount components are mixed on one printed-circuit board. Wave soldering can still be used for certain surface mount ICs, but it is not suitable for fine pitch SMDs. In these situations reflow soldering is recommended.

#### Through-hole mount packages

##### SOLDERING BY DIPPING OR BY SOLDER WAVE

The maximum permissible temperature of the solder is 260 °C; solder at this temperature must not be in contact with the joints for more than 5 seconds. The total contact time of successive solder waves must not exceed 5 seconds.

The device may be mounted up to the seating plane, but the temperature of the plastic body must not exceed the specified maximum storage temperature ( $T_{stg(max)}$ ). If the printed-circuit board has been pre-heated, forced cooling may be necessary immediately after soldering to keep the temperature within the permissible limit.

##### MANUAL SOLDERING

Apply the soldering iron (24 V or less) to the lead(s) of the package, either below the seating plane or not more than 2 mm above it. If the temperature of the soldering iron bit is less than 300 °C it may remain in contact for up to 10 seconds. If the bit temperature is between 300 and 400 °C, contact may be up to 5 seconds.

#### Surface mount packages

##### REFLOW SOLDERING

Reflow soldering requires solder paste (a suspension of fine solder particles, flux and binding agent) to be applied to the printed-circuit board by screen printing, stencilling or pressure-syringe dispensing before package placement.

Several methods exist for reflowing; for example, convection or convection/infrared heating in a conveyor type oven. Throughput times (preheating, soldering and cooling) vary between 100 and 200 seconds depending on heating method.

Typical reflow peak temperatures range from 215 to 250 °C. The top-surface temperature of the packages should preferably be kept below 220 °C for thick/large packages, and below 235 °C for small/thin packages.

##### WAVE SOLDERING

Conventional single wave soldering is not recommended for surface mount devices (SMDs) or printed-circuit boards with a high component density, as solder bridging and non-wetting can present major problems.

To overcome these problems the double-wave soldering method was specifically developed.

If wave soldering is used the following conditions must be observed for optimal results:

- Use a double-wave soldering method comprising a turbulent wave with high upward pressure followed by a smooth laminar wave.
- For packages with leads on two sides and a pitch (e):
  - larger than or equal to 1.27 mm, the footprint longitudinal axis is **preferred** to be parallel to the transport direction of the printed-circuit board;
  - smaller than 1.27 mm, the footprint longitudinal axis **must** be parallel to the transport direction of the printed-circuit board.

The footprint must incorporate solder thieves at the downstream end.

- For packages with leads on four sides, the footprint must be placed at a 45° angle to the transport direction of the printed-circuit board. The footprint must incorporate solder thieves downstream and at the side corners.

During placement and before soldering, the package must be fixed with a droplet of adhesive. The adhesive can be applied by screen printing, pin transfer or syringe dispensing. The package can be soldered after the adhesive is cured.

Typical dwell time is 4 seconds at 250 °C.

A mildly-activated flux will eliminate the need for removal of corrosive residues in most applications.

##### MANUAL SOLDERING

Fix the component by first soldering two diagonally-opposite end leads. Use a low voltage (24 V or less) soldering iron applied to the flat part of the lead. Contact time must be limited to 10 seconds at up to 300 °C. When using a dedicated tool, all other leads can be soldered in one operation within 2 to 5 seconds between 270 and 320 °C.



# Zero-voltage-switching resonant converter controller

TEA1610P; TEA1610T

## Suitability of IC packages for wave, reflow and dipping soldering methods

MOUNTING	PACKAGE	SOLDERING METHOD		
		WAVE	REFLOW <sup>(1)</sup>	DIPPING
Through-hole mount	DBS, DIP, HDIP, SDIP, SIL	suitable <sup>(2)</sup>	–	suitable
Surface mount	BGA, HBGA, LFBGA, SQFP, TFBGA	not suitable	suitable	–
	HBCC, HLQFP, HSQFP, HSOP, HTQFP, HTSSOP, HVQFN, SMS	not suitable <sup>(3)</sup>	suitable	–
	PLCC <sup>(4)</sup> , SO, SOJ	suitable	suitable	–
	LQFP, QFP, TQFP	not recommended <sup>(4)(5)</sup>	suitable	–
	SSOP, TSSOP, VSO	not recommended <sup>(6)</sup>	suitable	–

### Notes

- All surface mount (SMD) packages are moisture sensitive. Depending upon the moisture content, the maximum temperature (with respect to time) and body size of the package, there is a risk that internal or external package cracks may occur due to vaporization of the moisture in them (the so called popcorn effect). For details, refer to the Drypack information in the “*Data Handbook IC26; Integrated Circuit Packages; Section: Packing Methods*”.
- For SDIP packages, the longitudinal axis must be parallel to the transport direction of the printed-circuit board.
- These packages are not suitable for wave soldering as a solder joint between the printed-circuit board and heatsink (at bottom version) can not be achieved, and as solder may stick to the heatsink (on top version).
- If wave soldering is considered, then the package must be placed at a 45° angle to the solder wave direction. The package footprint must incorporate solder thieves downstream and at the side corners.
- Wave soldering is only suitable for LQFP, QFP and TQFP packages with a pitch (e) equal to or larger than 0.8 mm; it is definitely not suitable for packages with a pitch (e) equal to or smaller than 0.65 mm.
- Wave soldering is only suitable for SSOP and TSSOP packages with a pitch (e) equal to or larger than 0.65 mm; it is definitely not suitable for packages with a pitch (e) equal to or smaller than 0.5 mm.

# Zero-voltage-switching resonant converter controller

TEA1610P; TEA1610T

## DATA SHEET STATUS

DATA SHEET STATUS <sup>(1)</sup>	PRODUCT STATUS <sup>(2)</sup>	DEFINITIONS
Objective data	Development	This data sheet contains data from the objective specification for product development. Philips Semiconductors reserves the right to change the specification in any manner without notice.
Preliminary data	Qualification	This data sheet contains data from the preliminary specification. Supplementary data will be published at a later date. Philips Semiconductors reserves the right to change the specification without notice, in order to improve the design and supply the best possible product.
Product data	Production	This data sheet contains data from the product specification. Philips Semiconductors reserves the right to make changes at any time in order to improve the design, manufacturing and supply. Changes will be communicated according to the Customer Product/Process Change Notification (CPCN) procedure SNW-SQ-650A.

### Notes

1. Please consult the most recently issued data sheet before initiating or completing a design.
2. The product status of the device(s) described in this data sheet may have changed since this data sheet was published. The latest information is available on the Internet at URL <http://www.semiconductors.philips.com>.

### DEFINITIONS

**Short-form specification** — The data in a short-form specification is extracted from a full data sheet with the same type number and title. For detailed information see the relevant data sheet or data handbook.

**Limiting values definition** — Limiting values given are in accordance with the Absolute Maximum Rating System (IEC 60134). Stress above one or more of the limiting values may cause permanent damage to the device. These are stress ratings only and operation of the device at these or at any other conditions above those given in the Characteristics sections of the specification is not implied. Exposure to limiting values for extended periods may affect device reliability.

**Application information** — Applications that are described herein for any of these products are for illustrative purposes only. Philips Semiconductors make no representation or warranty that such applications will be suitable for the specified use without further testing or modification.

### DISCLAIMERS

**Life support applications** — These products are not designed for use in life support appliances, devices, or systems where malfunction of these products can reasonably be expected to result in personal injury. Philips Semiconductors customers using or selling these products for use in such applications do so at their own risk and agree to fully indemnify Philips Semiconductors for any damages resulting from such application.

**Right to make changes** — Philips Semiconductors reserves the right to make changes, without notice, in the products, including circuits, standard cells, and/or software, described or contained herein in order to improve design and/or performance. Philips Semiconductors assumes no responsibility or liability for the use of any of these products, conveys no licence or title under any patent, copyright, or mask work right to these products, and makes no representations or warranties that these products are free from patent, copyright, or mask work right infringement, unless otherwise specified.

---

Zero-voltage-switching  
resonant converter controller

TEA1610P; TEA1610T

---

**NOTES**

# Philips Semiconductors – a worldwide company

**Argentina:** see South America

**Australia:** 3 Figtree Drive, HOMEBUSH, NSW 2140,  
Tel. +61 2 9704 8141, Fax. +61 2 9704 8139

**Austria:** Computerstr. 6, A-1101 WIEN, P.O. Box 213,  
Tel. +43 1 60 101 1248, Fax. +43 1 60 101 1210

**Belarus:** Hotel Minsk Business Center, Bld. 3, r. 1211, Volodarski Str. 6,  
220050 MINSK, Tel. +375 172 20 0733, Fax. +375 172 20 0773

**Belgium:** see The Netherlands

**Brazil:** see South America

**Bulgaria:** Philips Bulgaria Ltd., Energoproject, 15th floor,  
51 James Bourchier Blvd., 1407 SOFIA,  
Tel. +359 2 68 9211, Fax. +359 2 68 9102

**Canada:** PHILIPS SEMICONDUCTORS/COMPONENTS,  
Tel. +1 800 234 7381, Fax. +1 800 943 0087

**China/Hong Kong:** 501 Hong Kong Industrial Technology Centre,  
72 Tat Chee Avenue, Kowloon Tong, HONG KONG,  
Tel. +852 2319 7888, Fax. +852 2319 7700

**Colombia:** see South America

**Czech Republic:** see Austria

**Denmark:** Sydhavnsgade 23, 1780 COPENHAGEN V,  
Tel. +45 33 29 3333, Fax. +45 33 29 3905

**Finland:** Sinikalliontie 3, FIN-02630 ESPOO,  
Tel. +358 9 615 800, Fax. +358 9 6158 0920

**France:** 7 - 9 Rue du Mont Valérien, BP317, 92156 SURESNES Cedex,  
Tel. +33 1 4728 6600, Fax. +33 1 4728 6638

**Germany:** Hammerbrookstraße 69, D-20097 HAMBURG,  
Tel. +49 40 2353 60, Fax. +49 40 2353 6300

**Hungary:** Philips Hungary Ltd., H-1119 Budapest, Fehervari ut 84/A,  
Tel: +36 1 382 1700, Fax: +36 1 382 1800

**India:** Philips INDIA Ltd, Band Box Building, 2nd floor,  
254-D, Dr. Annie Besant Road, Worli, MUMBAI 400 025,  
Tel. +91 22 493 8541, Fax. +91 22 493 0966

**Indonesia:** PT Philips Development Corporation, Semiconductors Division,  
Gedung Philips, Jl. Buncit Raya Kav.99-100, JAKARTA 12510,  
Tel. +62 21 794 0040 ext. 2501, Fax. +62 21 794 0080

**Ireland:** Newstead, Clonskeagh, DUBLIN 14,  
Tel. +353 1 7640 000, Fax. +353 1 7640 200

**Israel:** RAPAC Electronics, 7 Kehilat Saloniki St, PO Box 18053,  
TEL AVIV 61180, Tel. +972 3 645 0444, Fax. +972 3 649 1007

**Italy:** PHILIPS SEMICONDUCTORS, Via Casati, 23 - 20052 MONZA (MI),  
Tel. +39 039 203 6838, Fax +39 039 203 6800

**Japan:** Philips Bldg 13-37, Kohnan 2-chome, Minato-ku,  
TOKYO 108-8507, Tel. +81 3 3740 5130, Fax. +81 3 3740 5057

**Korea:** Philips House, 260-199 Itaewon-dong, Yongsan-ku, SEOUL,  
Tel. +82 2 709 1412, Fax. +82 2 709 1415

**Malaysia:** No. 76 Jalan Universiti, 46200 PETALING JAYA, SELANGOR,  
Tel. +60 3 750 5214, Fax. +60 3 757 4880

**Mexico:** 5900 Gateway East, Suite 200, EL PASO, TEXAS 79905,  
Tel. +9-5 800 234 7381, Fax +9-5 800 943 0087

**Middle East:** see Italy

**Netherlands:** Postbus 90050, 5600 PB EINDHOVEN, Bldg. VB,  
Tel. +31 40 27 82785, Fax. +31 40 27 88399

**New Zealand:** 2 Wagener Place, C.P.O. Box 1041, AUCKLAND,  
Tel. +64 9 849 4160, Fax. +64 9 849 7811

**Norway:** Box 1, Manglerud 0612, OSLO,  
Tel. +47 22 74 8000, Fax. +47 22 74 8341

**Pakistan:** see Singapore

**Philippines:** Philips Semiconductors Philippines Inc.,  
106 Valero St. Salcedo Village, P.O. Box 2108 MCC, MAKATI,  
Metro MANILA, Tel. +63 2 816 6380, Fax. +63 2 817 3474

**Poland:** Al.Jerozolimskie 195 B, 02-222 WARSAW,  
Tel. +48 22 5710 000, Fax. +48 22 5710 001

**Portugal:** see Spain

**Romania:** see Italy

**Russia:** Philips Russia, Ul. Usatcheva 35A, 119048 MOSCOW,  
Tel. +7 095 755 6918, Fax. +7 095 755 6919

**Singapore:** Lorong 1, Toa Payoh, SINGAPORE 319762,  
Tel. +65 350 2538, Fax. +65 251 6500

**Slovakia:** see Austria

**Slovenia:** see Italy

**South Africa:** S.A. PHILIPS Pty Ltd., 195-215 Main Road Martindale,  
2092 JOHANNESBURG, P.O. Box 58088 Newville 2114,  
Tel. +27 11 471 5401, Fax. +27 11 471 5398

**South America:** Al. Vicente Pinzon, 173, 6th floor,  
04547-130 SÃO PAULO, SP, Brazil,  
Tel. +55 11 821 2333, Fax. +55 11 821 2382

**Spain:** Balmes 22, 08007 BARCELONA,  
Tel. +34 93 301 6312, Fax. +34 93 301 4107

**Sweden:** Kottbygatan 7, Akalla, S-16485 STOCKHOLM,  
Tel. +46 8 5985 2000, Fax. +46 8 5985 2745

**Switzerland:** Allmendstrasse 140, CH-8027 ZÜRICH,  
Tel. +41 1 488 2741 Fax. +41 1 488 3263

**Taiwan:** Philips Semiconductors, 5F, No. 96, Chien Kuo N. Rd., Sec. 1,  
TAIPEI, Taiwan Tel. +886 2 2134 2451, Fax. +886 2 2134 2874

**Thailand:** PHILIPS ELECTRONICS (THAILAND) Ltd.,  
60/14 MOO 11, Bangna Trad Road KM. 3, Bagna, BANGKOK 10260,  
Tel. +66 2 361 7910, Fax. +66 2 398 3447

**Turkey:** Yukari Dudullu, Org. San. Blg., 2.Cad. Nr. 28 81260 Umraniye,  
ISTANBUL, Tel. +90 216 522 1500, Fax. +90 216 522 1813

**Ukraine:** PHILIPS UKRAINE, 4 Patrice Lumumba str., Building B, Floor 7,  
252042 KIEV, Tel. +380 44 264 2776, Fax. +380 44 268 0461

**United Kingdom:** Philips Semiconductors Ltd., 276 Bath Road, Hayes,  
MIDDLESEX UB3 5BX, Tel. +44 208 730 5000, Fax. +44 208 754 8421

**United States:** 811 East Arques Avenue, SUNNYVALE, CA 94088-3409,  
Tel. +1 800 234 7381, Fax. +1 800 943 0087

**Uruguay:** see South America

**Vietnam:** see Singapore

**Yugoslavia:** PHILIPS, Trg N. Pasica 5/v, 11000 BEOGRAD,  
Tel. +381 11 3341 299, Fax.+381 11 3342 553

**For all other countries apply to:** Philips Semiconductors,  
Marketing Communications, Building BE-p, P.O. Box 218, 5600 MD EINDHOVEN,  
The Netherlands, Fax. +31 40 27 24825

**Internet:** <http://www.semiconductors.philips.com>

© Philips Electronics N.V. 2001

SCA 72

All rights are reserved. Reproduction in whole or in part is prohibited without the prior written consent of the copyright owner.

The information presented in this document does not form part of any quotation or contract, is believed to be accurate and reliable and may be changed without notice. No liability will be accepted by the publisher for any consequence of its use. Publication thereof does not convey nor imply any license under patent- or other industrial or intellectual property rights.

Printed in The Netherlands

613502/01/pp20

Date of release: 2001 Apr 25

Document order number: 9397 750 07993

*Let's make things better.*

**Philips**  
Semiconductors



**PHILIPS**