

EM78P451S

8-Bit Microcontroller
with OTP ROM

Product Specification

DOC. VERSION 1.0

ELAN MICROELECTRONICS CORP.

June 2004



Trademark Acknowledgments:

IBM is a registered trademark and PS/2 is a trademark of IBM.

Windows is a trademark of Microsoft Corporation.

ELAN and ELAN logo  are trademarks of ELAN Microelectronics Corporation.

Copyright © 2005 by ELAN Microelectronics Corporation

All Rights Reserved

Printed in Taiwan

The contents of this specification are subject to change without further notice. ELAN Microelectronics assumes no responsibility concerning the accuracy, adequacy, or completeness of this specification. ELAN Microelectronics makes no commitment to update, or to keep current the information and material contained in this specification. Such information and material may change to conform to each confirmed order.

In no event shall ELAN Microelectronics be made responsible for any claims attributed to errors, omissions, or other inaccuracies in the information or material contained in this specification. ELAN Microelectronics shall not be liable for direct, indirect, special incidental, or consequential damages arising from the use of such information or material.

The software (if any) described in this specification is furnished under a license or nondisclosure agreement, and may be used or copied only in accordance with the terms of such agreement.

ELAN Microelectronics products are not intended for use in life support appliances, devices, or systems. Use of ELAN Microelectronics product in such applications is not supported and is prohibited.

NO PART OF THIS SPECIFICATION MAY BE REPRODUCED OR TRANSMITTED IN ANY FORM OR BY ANY MEANS WITHOUT THE EXPRESSED WRITTEN PERMISSION OF ELAN MICROELECTRONICS.



ELAN MICROELECTRONICS CORPORATION

Headquarters:

No. 12, Innovation Road 1
Hsinchu Science Park
Hsinchu, Taiwan 30077
Tel: +886 3 563-9977
Fax: +886 3 563-9966
<http://www.emc.com.tw>

Hong Kong:

Elan (HK) Microelectronics Corporation, Ltd.
Rm. 1005B, 10/F Empire Centre
68 Mody Road, Tsimshatsui
Kowloon, HONG KONG
Tel: +852 2723-3376
Fax: +852 2723-7780
elanhk@emc.com.hk

USA:

Elan Information Technology Group
1821 Saratoga Ave., Suite 250
Saratoga, CA 95070
USA
Tel: +1 408 366-8223
Fax: +1 408 366-8220

Europe:

Elan Microelectronics Corp. (Europe)

Siewerdtstrasse 105
8050 Zurich, SWITZERLAND
Tel: +41 43 299-4060
Fax: +41 43 299-4079
<http://www.elan-europe.com>

Shenzhen:

Elan Microelectronics Shenzhen, Ltd.

SSMEC Bldg., 3F, Gaoxin S. Ave.
Shenzhen Hi-Tech Industrial Park
Shenzhen, Guangdong, CHINA
Tel: +86 755 2601-0565
Fax: +86 755 2601-0500

Shanghai:

Elan Microelectronics Shanghai Corporation, Ltd.

23/Bldg. #115 Lane 572, Bibo Road
Zhangjiang Hi-Tech Park
Shanghai, CHINA
Tel: +86 021 5080-3866
Fax: +86 021 5080-4600



Contents

1	GENERAL DESCRIPTION	1
2	FEATURES	1
3	PIN ASSIGNMENT	2
4	FUNCTION DESCRIPTION	4
4.1	Operational Registers	4
4.1.1	R0 (Indirect Address Register)	4
4.1.2	R1 (TCC)	4
4.1.3	R2 (Program Counter) & Stack.....	4
4.1.4	R3 (Status Register)	6
4.1.5	R4 (RAM Select Register)	6
4.1.6	R5~R8 (Port 5 ~ Port8).....	7
4.1.7	R9 (Port9)	7
4.1.8	RA (SPIRB: SPI Read Buffer).....	8
4.1.9	RB (SPIWB: SPI Write Buffer).....	8
4.1.10	RC (SPIS: SPI Status Register).....	8
4.1.11	RD (SPIC: SPI Control Register).....	9
4.1.12	RE (TMR1: Timer1 register)	10
4.1.13	RF (PWP: Pulse width preset register).....	10
4.1.14	R20~R3E (General Purpose Register).....	10
4.1.15	R3F (Interrupt Status Register)	10
4.2	Special Purpose Registers	10
4.2.1	A (Accumulator)	10
4.2.2	CONT (Control Register)	11
4.2.3	IOC5 ~ IOC9 (I/O Port Control Register).....	11
4.2.4	IOCC (T1CON: Timer1 control register).....	11
4.2.5	IOCD (Pull-high Control Register)	12
4.2.6	IOCE (WDT Control Register)	12
4.2.7	IOCF (Interrupt Mask Register)	13
4.3	TCC/WDT Prescaler	14
4.4	I/O Ports	15
4.5	SERIAL PERIPHERAL INTERFACE MODE	17
4.5.1	Overview & Features	17
4.5.2	SPI Function Description	19
4.5.3	SPI Signal & Pin Description	20
4.5.4	Programmed the related registers.....	22
4.5.5	SPI Mode Timing	24
4.5.6	Software Application of SPI	25
4.6	Timer 1	30
4.6.1	Overview.....	30
4.6.2	Function description	30



4.6.3 Programmed the related registers..... 30

4.7 RESET and Wake-up 31

4.8 Interrupt..... 37

4.9 Oscillator 38

 4.9.1 Oscillator Modes..... 38

 4.9.2 Crystal Oscillator/Ceramic Resonators (XTAL) 38

 4.9.3 RC Oscillator Mode 40

4.10 Code Option Register..... 41

4.11 Instruction Set 42

4.12 Timing Diagrams 45

5 ABSOLUTE MAXIMUM RATING 46

6 ELECTRICAL CHARACTERISTICS 46

 6.1 DC Characteristic 46

 6.2 AC Characteristic 47

7 Application Circuit 48

APPENDIX

A Package Types 49

B Package Information..... 49

Specification Revision History

Doc. Version	Revision Description	Date
1.0	Initial version	06/01/2004



1 GENERAL DESCRIPTION

The EM78P451S is an 8-bit microprocessor designed and developed with low-power, high speed CMOS technology. Its operational kernel is implemented with RISC-like architecture and is available in the mask ROM version. The one time programmable (OTP) version is flexible, both in mass production or engineering test stages. OTP provide users with unlimited volume with favorable price opportunities. This device is equipped with the Serial Peripheral Interface (SPI) function. The EM78P451S is very suitable for wired communication. Only 58 easy-to-learn instructions are needed and user's program can be emulated with EMC In-Circuit Emulator (ICE).

2 FEATURES

- Operating voltage range: 2.3V~5.5V.
- Operating temperature range: 0°C~70°C.
- Operating frequency range (base on 2 clocks):
 - Crystal mode: DC~20MHz at 5V, DC~8MHz at 3V, DC~4MHz at 2.3V.
 - RC mode: DC~4MHz at 5V, DC~4MHz at 3V, DC~4MHz at 2.3V.
- Low power consumption:
 - Less then 3 mA at 5V/4MHz
 - Typically 10 μ A during sleep mode
- Serial Peripheral Interface (SPI) available.
- 4K \times 13 bits on chip ROM (EM78P451S).
- 11 special function registers.
- 140 \times 8 bits on chip general-purposed registers.
- 5 bi-directional I/O ports (35 I/O pins).
- 3 LED direct sinking pins with internal serial resistors.
- Built-in RC oscillator with external serial resistor, \pm 10% variation.
- Built-in power-on reset.
- 5 stacks for subroutine nesting.
- 8-bit real time clock/counter (TCC) with overflow interrupt.
- Two machine clocks or four machine clocks per instruction cycle.
- Power down mode.
- Programmable wake up from sleep circuit on I/O ports.
- Programmable free running on-chip watchdog timer.



- 12 wake-up pins.
- 2 open-drain pins.
- 2 R-option pins.
- 32 programmable pull-high input pins.
- Packages:
 - 40 pin DIP 600mil: EM78P451SP .
 - 40 pin SOP 450mil: EM78P451SWM
 - 44 pin QFP: EM78P451SAQ.
- Four types of interrupts.
 - External interrupt (/INT).
 - SPI transmission completed interrupt.
 - TCC overflow interrupt.
 - Timer1 comparator match interrupt.

3 PIN ASSIGNMENT

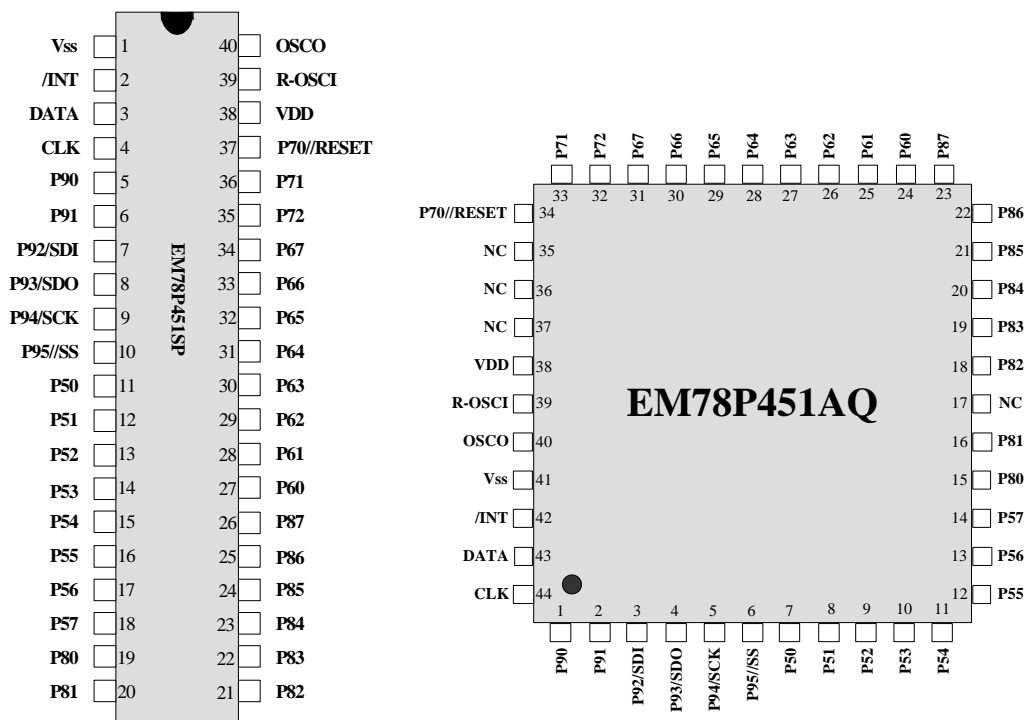

Fig. 1 Pin Assignment



Table 1 Pin description

Symbol	Pin No.	Type	Function Description
R-OSCI	39	I	<ul style="list-style-type: none"> In XTAL mode: Crystal input; In internal C, external R mode: 56Kohm±5% pull high for 1.8432MHz.
OSCO	40	O	<ul style="list-style-type: none"> In XTAL mode: Crystal output; In RC mode: Instruction clock output.
P90~P95	5~10	I/O	<ul style="list-style-type: none"> General bi-directional I/O port. All of its pins can be pulled-high by software. P90 and P91 are pin-change wake up pins.
P80~P87	19~26	I/O	<ul style="list-style-type: none"> General bi-directional I/O port. All of its pins can be pulled-high by software. P80 and P81 are also used as the R-option pins.
P70~P72	37~35	I/O	<ul style="list-style-type: none"> LED direct-driving pin with internal serial resistor used as output and is software defined.
P70/ RESET	37	I/O	<ul style="list-style-type: none"> LED direct-driving pin with internal serial resistor used as output and is software defined. Code option bit 3 (REN): reset enable REN=0 => for reset pin REN=1 => for general purpose I/O (P70) Internal pull high resistor 220Kohm
CLK	4	I/O	<ul style="list-style-type: none"> By connecting P74 and P76 together. P74 can be pulled-high by software and it is also a pin-change wake up pin. P76 can be defined as an open-drain output.
DATA	3	I/O	<ul style="list-style-type: none"> By connecting P75 and P77 together. P75 can be pulled-high by software and it is also a pin-change wake up pin. P77 can be defined as an open-drain output.
P60~P67	27~34	I/O	<ul style="list-style-type: none"> General bi-directional port. All of its pins can be pulled-high by software, and pin-change wake up pins.
P50~P57	11~18	I/O	<ul style="list-style-type: none"> General bi-directional I/O port. All of its pins can be pulled-high individually by software.
VDD	38	-	<ul style="list-style-type: none"> Power supply pin.
VSS	1	-	<ul style="list-style-type: none"> Ground pin.
/INT	2	I	<ul style="list-style-type: none"> An interrupt schmitt-triggered pin. The function of interrupt triggers at the falling edge. Users can enable it by software.
SDI	7	I/O	<ul style="list-style-type: none"> Serial data in for SPI
SDO	8	I/O	<ul style="list-style-type: none"> Serial data out for SPI.
SCK	9	I/O	<ul style="list-style-type: none"> Serial clock for SPI.
/SS	10	I/O	<ul style="list-style-type: none"> /Slave select for SPI.

4 FUNCTION DESCRIPTION

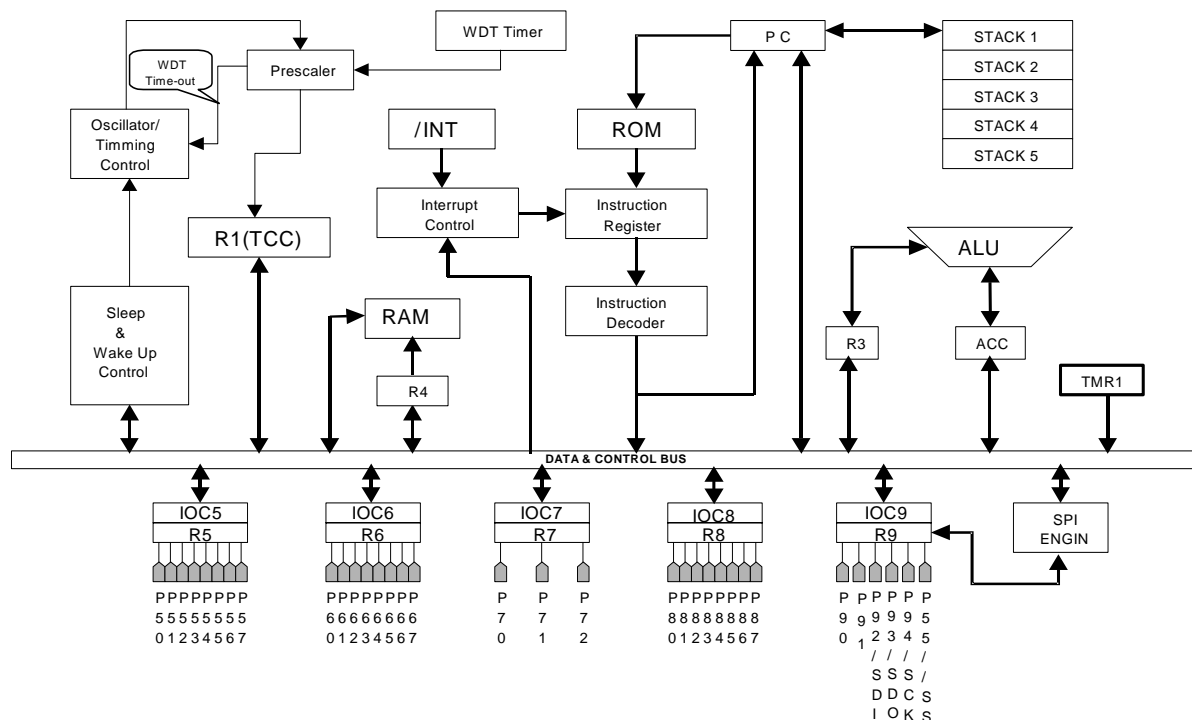

Fig. 2 Functional Block Diagram

4.1 Operational Registers

4.1.1 R0 (Indirect Address Register)

R0 is not a physically implemented register. It is used as an indirect addressing pointer. Any instruction using R0 as register actually accesses data pointed by the RAM Select Register (R4).

4.1.2 R1 (TCC)

- Increased by the instruction cycle clock.
- Written and read by program as any other register.

4.1.3 R2 (Program Counter) & Stack

- R2 and the hardware stacks are 12 bits wide.
- The structure is depicted in Fig. 3.
- Generates $4K \times 13$ on-chip ROM addresses to the relative programming instruction codes. One program page is 1024 words long.
- All the R2 bits are set to "1"s as a RESET condition occurs.

- "JMP" instruction allows direct loading of the lower 10 program counter bits. Thus, "JMP" allows jump to any location on one page.
- "CALL" instruction loads the lower 10 bits of the PC, and then PC+1 is pushed into the stack. Thus, the subroutine entry address can be located anywhere within a page
- "RET" ("RETL k", "RETI") instruction loads the program counter with the contents at the top of stack.
- "MOV R2, A" allows the loading of an address from the "A" register to the lower 8 bits of PC, and the ninth and tenth bits (A8~A9) of PC are cleared.
- "ADD R2, A" allows a relative address be added to the current PC, and the ninth and tenth bits of PC are cleared.
- Any instruction that is written to R2 (e.g. "ADD R2, A", "MOV R2, A", "BC R2,6",.....) (except "TBL") will cause the ninth and tenth bits (A8~A9) of PC to be cleared. Thus, the computed jump is limited to the first 256 locations of any program page.
- "TBL" allows a relative address be added to the current PC ($R2+A \rightarrow R2$), and contents of the ninth and tenth bits (A8~A9) of PC are not changed. Thus, the computed jump can be on the second (or third, 4th) 256 locations on one program page.
- In case of EM78P451S, the most significant bits (A10~A11) will be loaded with the contents of bits PS0~PS1 in the status register (R3) upon the execution of a "JMP", "CALL", or any other instructions which writes to R2.
- All instructions are single instruction cycle (fclk/2 or fclk/4) except for the instruction that would change the contents R2. Such instruction will need one more instruction cycle.

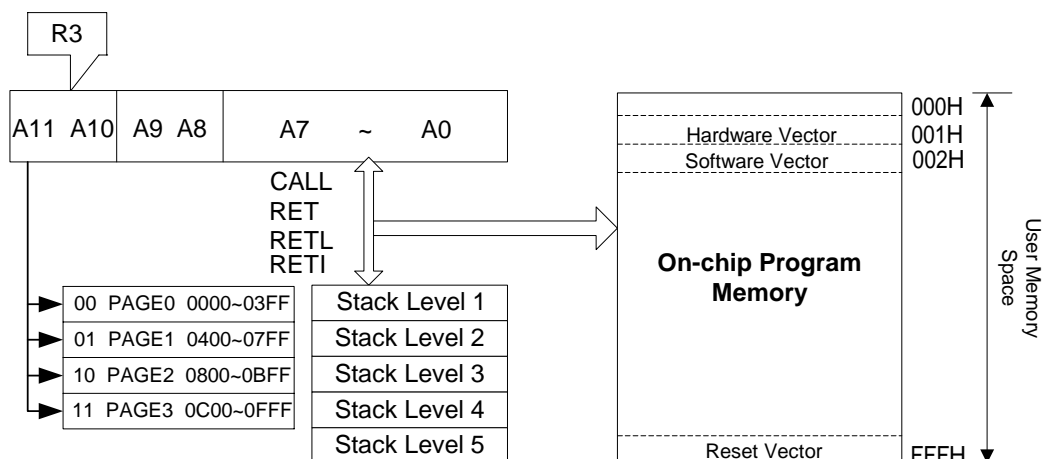

Fig. 3 Program Counter Organization



4.1.4 R3 (Status Register)

7	6	5	4	3	2	1	0
GP	PS1	PS0	T	P	Z	DC	C

Bit7 (GP) General read/write bit.

Bit6 (PS1) ~ 5 (PS0) Page select bits. PS0~PS1 are used to pre-select a program memory page. When executing a "JMP", "CALL", or other instructions which causes the program counter to be changed (e.g. MOV R2, A), PS0~PS1 are loaded into the 11th and 12th bits of the program counter where it selects selecting one of the available program memory pages. Note that RET (RETL, RETI) instruction does not change the PS0~PS1 bits. That is, the return will always be to the page from where the subroutine was called, regardless of the current setting of PS0~PS1 bits. PS1 bit is not used (read as "0") and cannot be modified in EM78P451S.

PS1	PS0	Program memory page [Address]
0	0	Page 0 [000-3FF]
0	1	Page 1 [400-7FF]
1	0	Page 2 [800-BFF]
1	1	Page 3 [C00-FFF]

Bit 4 (T) Time-out bit. Set to 1 with the "SLEP" and the "WDTC" commands, or during power up and reset to 0 with WDT timeout.

Bit 3 (P) Power down bit. Set to 1 during power on or by a "WDTC" command and reset to 0 by a "SLEP" command.

Bit 2 (Z) Zero flag. Set to "1" if the result of an arithmetic or logic operation is zero.

Bit 1 (DC) Auxiliary carry flag

Bit 0 (C) Carry flag

4.1.5 R4 (RAM Select Register)

Bits 7~6 determine which bank is activated among the 4 banks.

Bits 5~0 are used to select the registers (address: 00~3F) in the indirect addressing mode.

If no indirect addressing is used, the RSR is used as an 8-bit general-purposed read/writer register.

See the configuration of the data memory in Fig. 4.

4.1.6 R5~R8 (Port 5 ~ Port8)

- Four general 8 bits I/O registers
- Both P74 and P76 read or write data from the DATA pin, while both P75 and P77 read or write data from the CLK pin.

4.1.7 R9 (Port9)

- A general 6-bit I/O register. The values of the two most significant bits are read as "0".

Address	R PAGE registers				IOC PAGE registers
00	R0 (Indirect Addressing Register)				Reserve
01	R1 (Time Clock Counter)				CONT (Control Register)
02	R2 (Program Counter)				Reserve
03	R3 (Status Register)				Reserve
04	R4 (RAM Select Register)				Reserve
05	R5 (Port5)				IOC5 (I/O Port Control Register)
06	R6 (Port6)				IOC6 (I/O Port Control Register)
07	R7 (Port7)				IOC7 (I/O Port Control Register)
08	R8 (Port8)				IOC8 (I/O Port Control Register)
09	R9 (Port9)				IOC9 (I/O Port Control Register)
0A	RA (SPI read buffer)				Reserve
0B	RB (SPI write buffer)				Reserve
0C	RC (SPI status buffer)				IOCC (Timer1 Control Register)
0D	RD (SPI control buffer)				IOCD (Pull_high Control Register)
0E	RE (Timer1 register)				IOCE (WDT Control Register)
0F	RF (Pulse width preset register)				IOCF (Interrupt Mask Register)
10 : 1F	General Registers				
20 : 3E	Bank0	Bank1	Bank2	Bank3	
3F	R3F (Interrupt Status Register)				

Fig. 4 Data memory configuration



4.1.8 RA (SPIRB: SPI Read Buffer)

Address	Name	Bit 7	Bit 6	Bit 5	Bit 4	Bit 3	Bit 2	Bit 1
0X0A	SPIRB/RA	SRB7	SRB6	SRB5	SRB4	SRB3	SRB2	SRB1

- SRB7~SRB0 are the 8-bit data when complete transmission by SPI.

4.1.9 RB (SPIWB: SPI Write Buffer)

Address	Name	Bit 7	Bit 6	Bit 5	Bit 4	Bit 3	Bit 2	Bit 1	Bit 0
0x0B	SPIWB/RB	SWB7	SWB6	SWB5	SWB4	SWB3	SWB2	SWB1	SWB0

- SWB7~SWB0 are the 8-bit data that are waiting for transmission by SPI.

4.1.10 RC (SPIS: SPI Status Register)

Address	Name	Bit 7	Bit 6	Bit 5	Bit 4	Bit 3	Bit 2	Bit 1	Bit 0
0x0C	SPIS/RC	--	--	--	TM1IF	OD3	OD4	RBFIF	RBF

Bits 7 ~ 5 Not used.

Bit 4 (TM1IF):

0 = In timer1 mode, receiving not completed yet, and an interrupt does not occur.

1 = In timer1 mode, receiving completed, and an interrupt occurs if enabled.

Bit 3 (OD3): Open-Drain Control bit

0 = Open-drain disable for SDO.

1 = Open-drain enable for SDO,

Bit 2 (OD4): Open-Drain Control bit

0 = Open-drain disable for SCK.

1 = Open-drain enable for SCK,

Bit 1 (RBFIF): Read Buffer Full Interrupt Flag

0 = Receiving not completed yet; and SPIRB has not fully exchanged.

1 = Receiving completed, SPIRB is fully exchanged, and an interrupt occurs if enabled.

Bit 0 (RBF): Read Buffer Full flag

0 = Receiving not completed yet, and SPIRB has not fully exchanged.

1 = Receiving completed; SPIRB is fully exchanged.



4.1.11 RD (SPIC: SPI Control Register)

Address	Name	Bit 7	Bit 6	Bit 5	Bit 4	Bit 3	Bit 2	Bit 1	Bit 0
0x0D	SPIC/RD	CES	SPIE	SRO	SSE	-	SBRS2	SBRS1	SBRS0

Bit 7 (CES): Clock Edge Select bit

0 = Data shifts out on rising edge, and shifts in on falling edge. Data is on hold during the low level.

1 = Data shifts out on falling edge, and shifts in on rising edge. Data is on hold during the high level.

Bit 6 (SPIE): SPI Enable bit

0= Disable SPI mode

1= Enable SPI mode

Bit 5 (SRO): SPI Read Overflow bit

0 = No overflow

1 = A new data is received while the previous data is still being held in the SPIB register. In this situation, the data in SPIS register will be destroyed. To avoid setting this bit, users had better read SPIRB register even if only the transmission is implemented.

NOTE

This can only occur in slave mode.

Bit 4 (SSE): SPI Shift Enable bit

0 = Reset as soon as the shifting is complete, and the next byte is ready to shift.

1 = Start to shift, and keep on 1 while the current byte is still being transmitted.

NOTE

This bit will reset to 0 at every one-byte transmission by the hardware

Bit 2~Bit 0 (SBRS): SPI Baud Rate Select bits

SPI baud rate table is illustrated in SPI section in later pages.



4.1.12 RE (TMR1: Timer1 register)

Address	Name	Bit 7	Bit 6	Bit 5	Bit 4	Bit 3	Bit 2	Bit 1	Bit 0
0X0E	TMR1/RE	TMR17	TMR16	TMR15	TMR14	TMR13	TMR12	TMR11	TMR10

TMR17~TMR10 is bit set of timer1 register and it increases until the value matches PWP and then, it resets to 0.

4.1.13 RF (PWP: Pulse width preset register)

Address	Name	Bit 7	Bit 6	Bit 5	Bit 4	Bit 3	Bit 2	Bit 1	Bit 0
0x0F	PWP/RF	PWP7	PWP6	PWP5	PWP4	PWP3	PWP2	PWP1	PWP0

PWP7~PWP0 is bit set of pulse width preset in advance for the desired width of baud clock.

4.1.14 R20~R3E (General Purpose Register)

RA~R1F, and R20~R3E (including Banks 0~3) are general-purpose registers.

4.1.15 R3F (Interrupt Status Register)

Address	Name	Bit 7	Bit 6	Bit 5	Bit 4	Bit 3	Bit 2	Bit 1	Bit 0
0x3F	ISR/R3F	-	-	-	-	TM1IF	SPIIF	EXIF	TCIF

Bits 7~4 are not used and read as "0".

Bit 3 (TM1IF) Timer1 interrupt flag. Set by the comparator at Timer1 application, flag cleared by software.

Bit 2 (SPIIF) SPI interrupt flag. Set by data transmission complete, flag cleared by software.

Bit 1 (EXIF) External interrupt flag. Set by falling edge on /INT pin, flag cleared by software

Bit 0 (TCIF) the flag of the TCC overflow interrupt. Set as TCC overflow; flag cleared by software.

- "1" means interrupt request, "0" means non-interrupt.
- R3F can be cleared by instruction, but cannot be set by instruction.
- IOCF is the interrupt mask register.
- Note that to read R3F will result to "logic AND" of R3F and IOCF.

4.2 Special Purpose Registers

4.2.1 A (Accumulator)

- Internal data transfer, or instruction operand holding.
- A non-addressable register.



4.2.2 CONT (Control Register)

7	6	5	4	3	2	1	0
/PHEN	/INT	-	-	PAB	PSR2	PSR1	PSR0

Bit 7 (/PHEN) I/O pin pull-high enable flag.

0: For P60~P67, P74~P75 and P90~P95, the pull-high function is enabled.

1: The pull-high function is disabled.

Bit 6 (INT) An interrupt enable flag cannot be written by the CONTW instruction.

0: interrupt masked by the DISI instruction.

1: interrupt enabled by the ENI or RETI instruction.

Bit5, 4 Not used, and to be read as "0".

Bit 3 (PAB) Prescaler assignment bit.

0: TCC

1: WDT

Bit 2 (PSR2) ~ Bit 0 (PSR0) TCC/WDT prescaler bits.

PSR2	PSR1	PSR0	TCC Rate	WDT Rate
0	0	0	1:2	1:1
0	0	1	1:4	1:2
0	1	0	1:8	1:4
0	1	1	1:16	1:8
1	0	0	1:32	1:16
1	0	1	1:64	1:32
1	1	0	1:128	1:64
1	1	1	1:256	1:128

Bits 0~3, and 7 of the CONT register are readable and writable.

4.2.3 IOC5 ~ IOC9 (I/O Port Control Register)

- "1" put the relative I/O pin into high impedance, while "0" put the relative I/O pin as output.
- Both P74 and P76 should not be defined as output pins at the same time. This also applies to both P75 and P77.
- Only the lower 6 bits of the IOC9 register are used.

4.2.4 IOCC (T1CON: Timer1 control register)

Address	Name	Bit 7	Bit 6	Bit 5	Bit 4	Bit 3	Bit 2	Bit 1	Bit 0
0x0C	T1CON/IOCC	0	0	0	0	0	TM1E	TM1P1	TM1P0



Bit2 (TM1E): Timer1 Function Enable bit

0 = Disable timer1 function as default.

1 = Enable timer1 function.

Bit1~Bit0 (TM1P): Timer1 Prescaler bit

Timer1 prescaler table for FOSC will be illustrated in the Section on Timer1 in later pages.

4.2.5 IOCD (Pull-high Control Register)

7	6	5	4	3	2	1	0
S7	-	-	-	/PU9	/PU8	/PU6	/PU5

- The default values of /PU5, /PU6, /PU8, and /PU9 are one, which means the pull-high function is disabled.
- /PU6 and /PU9 are “AND” gating with /PHEN, that is, when each one is written as “0” pull high is enabled.
- S7 defines the driving ability of the P70-P72.
 0: Normal output.
 1: Enhance the driving ability of LED.

4.2.6 IOCE (WDT Control Register)

7	6	5	4	3	2	1	0
-	ODE	WDTE	SLPC	ROC	-	-	/WUE

Bits 7, and1~2 Not used.

Bit 6 (ODE) Open-drain control bit.

0: Both P76 and P77 are normally I/O pins.

1: Both P76 and P77 pins have the open-drain function inside.

The ODE bit can be read and written.

Bit 5 (WDTE) Control bit used to enable Watchdog timer.

The WDTE bit can be used only if ENWDT, the CODE Option bit, is "1". If the ENWDT bit is "1", then WDT can be disabled/enabled by the WDTE bit.

0: Disable WDT.

1: Enable WDT.

The WDTE bit is not used if ENWDT, the CODE Option bit ENWDT, is "0". That is, if the ENWDT bit is "0", WDT is always disabled no matter what the WDTE bit is.

The WDTE bit can be read and written.



Bit 4 (SLPC) This bit is set by hardware at the falling edge of wake-up signal and is cleared in software. SLPC is used to control the oscillator operation. The oscillator is disabled (oscillator is stopped, and the controller enters the SLEEP2 mode) on the high-to-low transition and is enabled (the controller is awakened from SLEEP2 mode) on low-to-high transition. In order to ensure the stable output of the oscillator, once the oscillator is enabled again, there is a delay for approximately 18 ms (oscillator start-up timer (OST)) before the next program instruction is executed. The OST is always activated by wake-up from sleep mode whether the Code Option bit ENWDT is "0" or not. After waking up, the WDT is enabled if Code Option ENWDT is "1". The block diagram of SLEEP2 mode and wake-up caused by input triggered is depicted in Fig. 5. The SLPC bit can be read and written.

Bit 3 (ROC) ROC is used for the R-option. Setting ROC to "1" will enable the status of R-option pins (P80, P81) to be read by the controller. Clearing ROC will disable the R-option function. Otherwise, the R-option function is introduced. Users must connect the P81 pin or/and P80 pin to VSS by a 560KΩ external resistor (Rex). If Rex is connected/disconnected with VDD, the status of P80 (P81) will be read as "0"/"1" (refer to Fig. 7(b)). The ROC bit can be read and written.

Bit 0 (WUE) Control bit used to enable the wake-up function of P60~P67, P74~P75, and P90~P91.

0: Enable the wake-up function.

1: Disable the wake-up function.

The /WUE bit can be read and written.

4.2.7 IOCF (Interrupt Mask Register)

7	6	5	4	3	2	1	0
-	-	-	-	TM1IE	SPIIE	EXIE	TCIE

Bits 4~7 Not used.

Individual interrupt is enabled by setting its associated control bit in IOCF to "1".

The IOCF Register could be read and written.

Bit 3 (TM1IE) TM1IE interrupt enable bit.

0: disable TM1IE interrupt

1: enable TM1IE interrupt

Bit 2 (SPIIE) SPI interrupt enable bit.

0: disable SPI interrupt

1: enable SPI interrupt

Bit 1 (EXIE) EXIF interrupt enable bit.

0: disable EXIF interrupt

1: enable EXIF interrupt

Bit 0 (TCIE) TCIF interrupt enable bit.

0: disable TCIF interrupt

1: enable TCIF interrupt

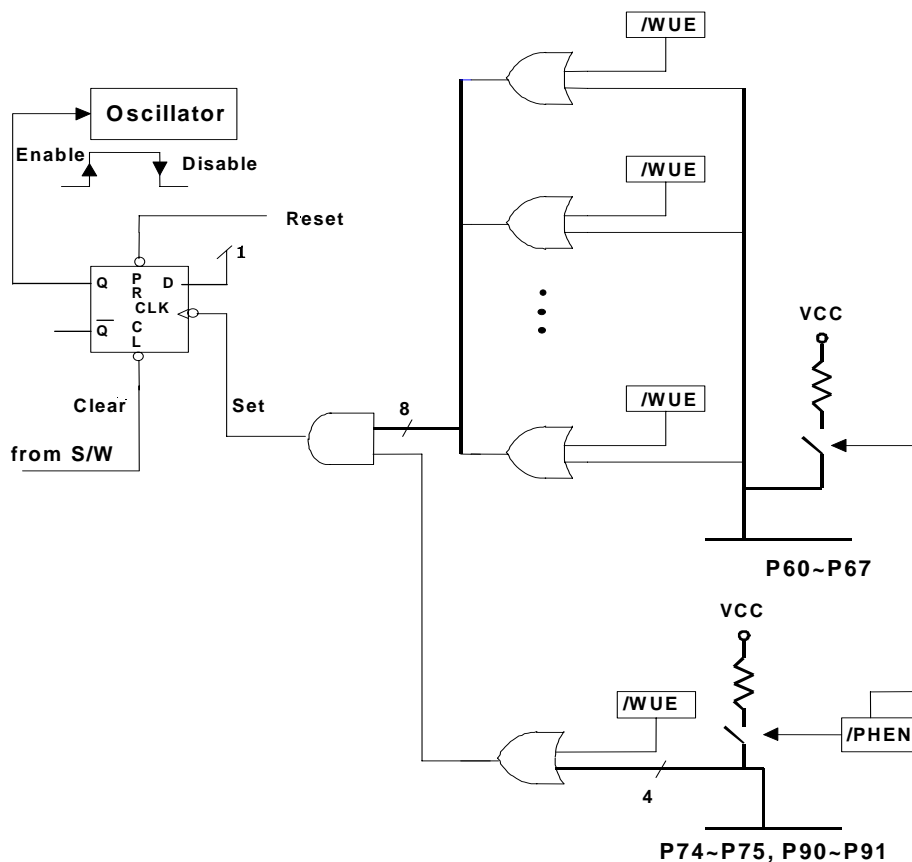

Fig. 5 Block Diagram of Sleep Mode and Wake-up Circuits on I/O Ports

4.3 TCC/WDT Prescaler

An 8-bit counter is available as prescaler for the TCC or WDT. The prescaler is available for either the TCC or WDT only at any given time, and the PAB bit of CONT register is used to determine the prescaler assignment. The PSR0~PSR2 bits determine the prescale ratio. The prescaler is cleared each time the instruction is written to TCC under TCC mode. The WDT and prescaler, when assigned to WDT mode, are cleared by the WDTC or SLEP instructions. Fig. 6 depicts the circuit diagram of TCC/WDT.

- R1(TCC) is an 8-bit timer/counter. TCC will increase by one at every instruction cycle (without prescaler).

- The watchdog timer is a free running on-chip RC oscillator. The WDT will keep running even when the oscillator driver has been turned off (i.e. in sleep mode). During normal operation or sleep mode, a WDT time-out (if enabled) will cause the device to reset. The WDT can be enabled or disabled any time during the normal mode by software programming (if Code Option bit ENWDT is "1"). Refer to WDTEbit of IOCE register. Without prescaler, the WDT time-out period is approximately 18 ms¹.

4.4 I/O Ports

The I/O registers, from Port 5 to Port 9, are bi-directional tri-state I/O ports. P60~P67, P74~P75, and P90~P91 provide internal pull-high. P60~P67, P74~P75, and P90~P95 provide programmable wake-up function through software. P76~P77 can have open-drain output by software control. P80~P81 are the R-option pins which are enabled by software. When the R-option function is used, it is recommended that P80 and P81 are used as output pins. During R-option enabled state, P80 and P81 must be programmed as input pins. If an external resistor is connected to P80 (P81) for the R-option function, the current consumption should be taken as an important factor in the applications for low power consideration.

The I/O ports can be defined as "input" or "output" pins by the I/O control registers (IOC5~IOC9) under program control. The I/O registers and I/O control registers are both readable and writable. The I/O interface circuit is shown in Fig. 7. Note that the reading path source of input and output pins is different when reading the I/O port.

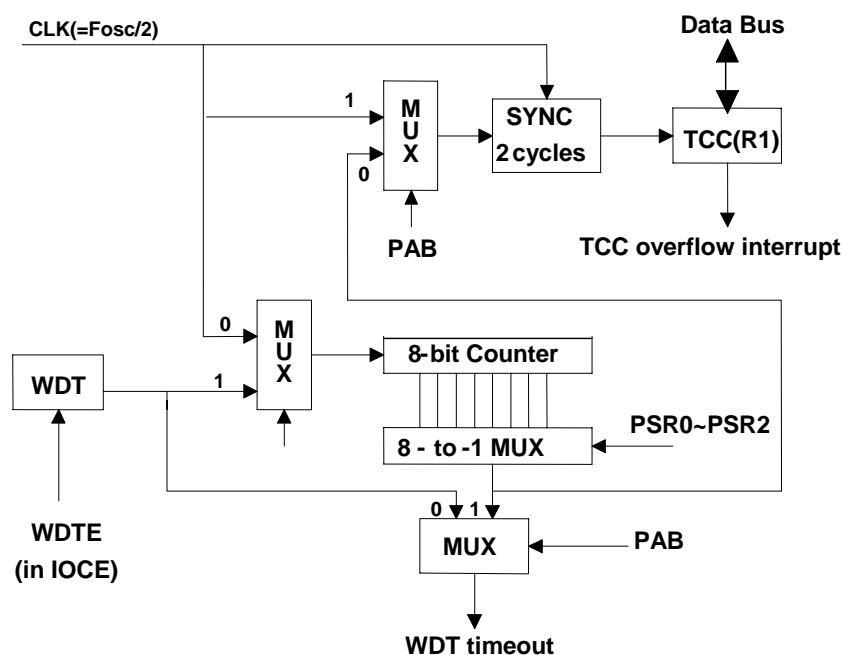

Fig. 6 Block Diagram of TCC WDT

¹ NOTE: Vdd = 5V, set up time period = 16.2ms ± 30%
Vdd = 3V, set up time period = 18.0ms ± 30%

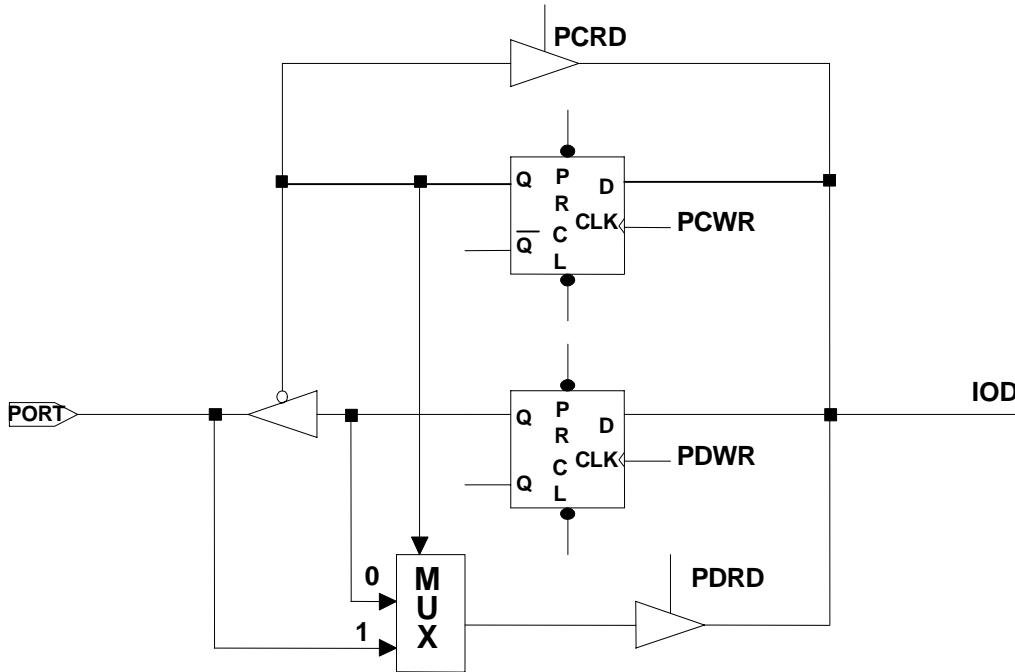

Fig. 7 (a) The Circuit of I/O Port and I/O Control Register

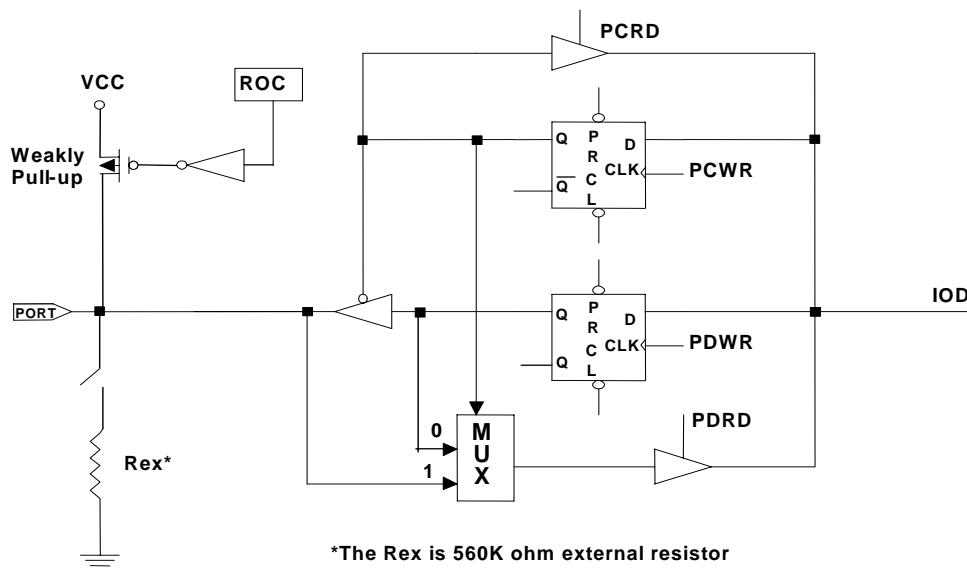

Fig.7(b) The Circuit of I/O Port with R-option (P80, P81)

4.5 SERIAL PERIPHERAL INTERFACE MODE

4.5.1 Overview & Features

Overview:

Figures 8, 9, and 10 show how EM78P451S communicates with other devices through SPI module. If EM78P451S is a master controller, it sends clock through the SCK pin. A couple of 8-bit data are transmitted and received at the same time. However, if EM78P451S is defined as a slave, its SCK pin could be programmed as an input pin. Data will continue to be shifted based on both the clock rate and the selected edge.

Features:

- Operation in either Master mode or Slave mode,
- Three-wire or four-wire synchronous communication; that is, full duplex
- Programmable baud rates of communication,
- Programming clock polarity, (RD bit7)
- Interrupt flag available for the read buffer full,
- Up to 8 MHz (maximum) bit frequency,

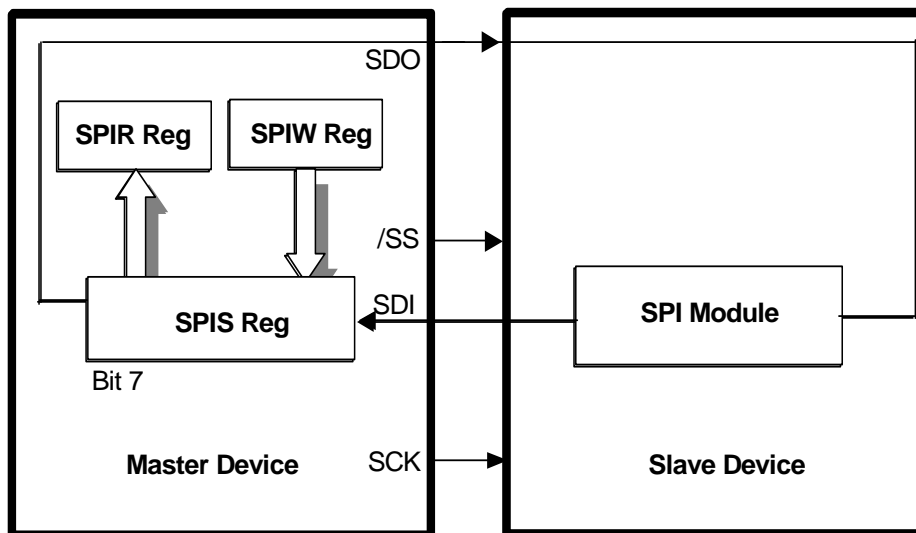

Fig. 8 SPI Master/Slave Communication

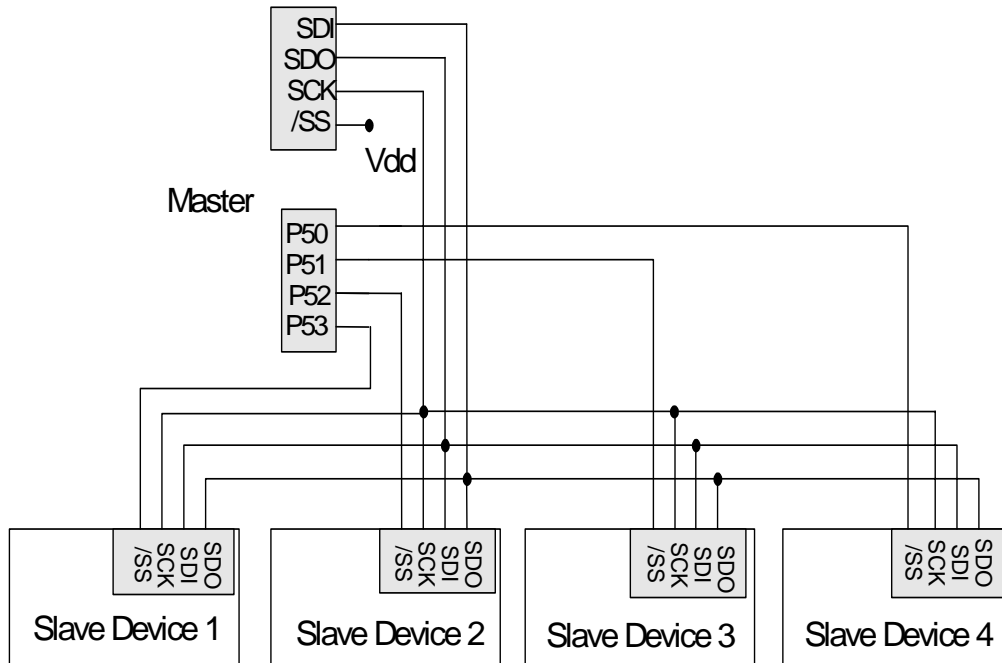

Fig. 9 The SPI Configuration of Single-Master and Multi-Slave

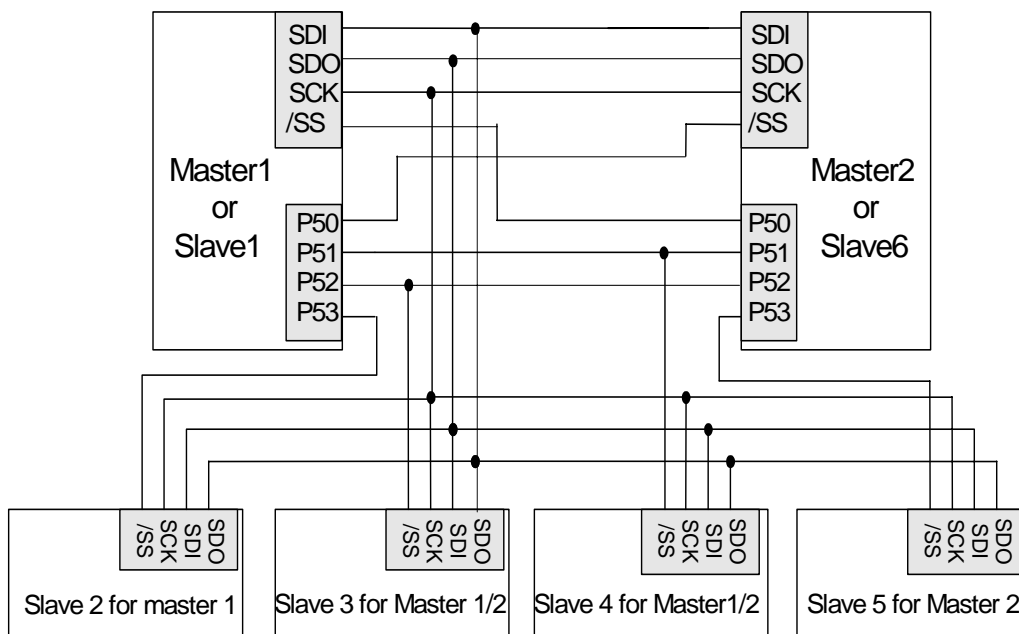

Fig. 10 The SPI Configuration of Single-Master and Multi-Slave

4.5.2 SPI Function Description

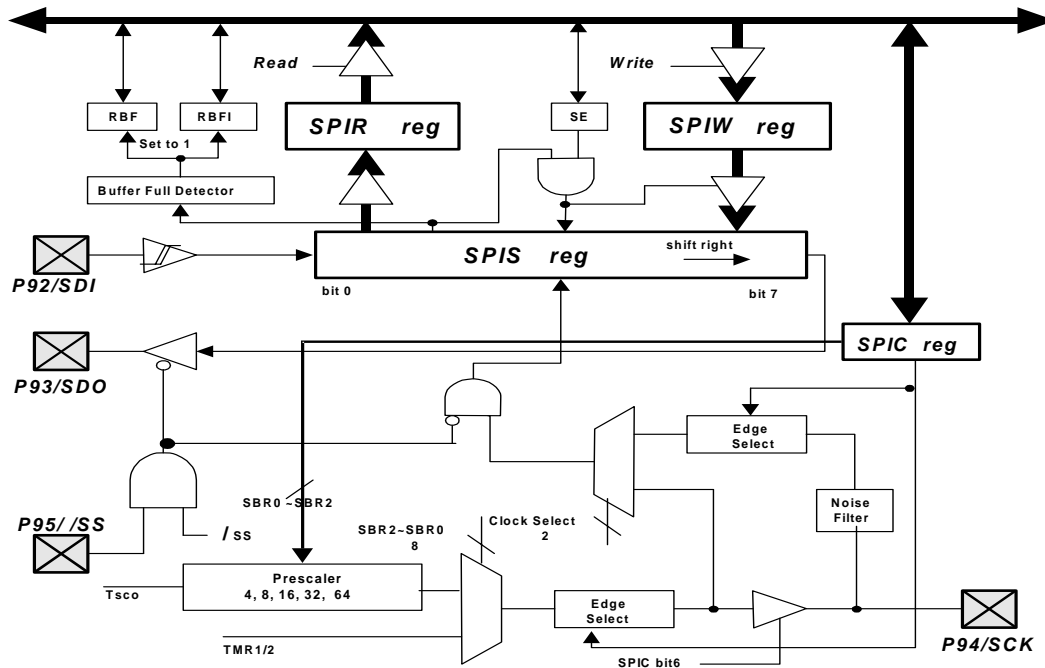

Fig. 11 SPI Block Diagram

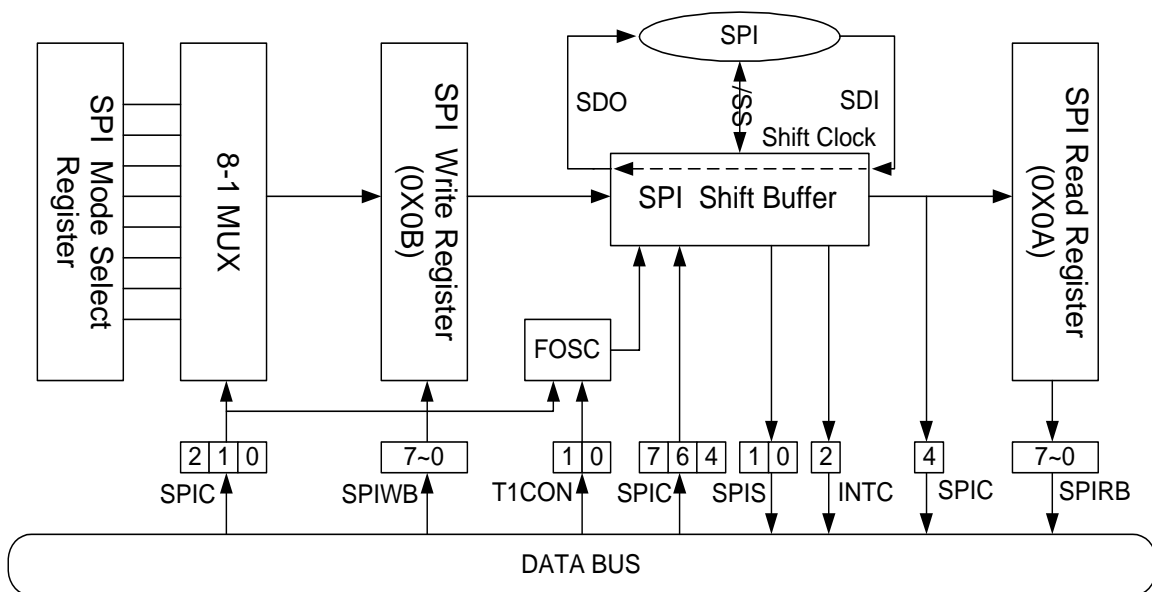

Fig. 12 The Function Block Diagram of SPI Transmission

The following describes the function of each block and explains how to carry out the SPI communication with the signals depicted in Fig.11 and Fig.12:



- P92/SDI:Serial Data In.
- P93/SDO:Serial Data Out.
- P94/SCK:Serial Clock.
- P95//SS:/Slave Select (Option). This pin (/SS) may be required during a slave mode.
- RBF: Set by Buffer Full Detector, and reset in software.
- RBIF: Set by Buffer Full Detector, and reset in software.
- Buffer Full Detector: Sets to 1 when an 8-bit shifting is completed.
- SSE: Loads the data in SPIS register, and begin to shift
- SPIS reg.:Shifting byte in and out. The MSB is shifted first. Both the SPIS register and the SPIW register are loaded at the same time. Once data are written, SPIS starts transmission / reception. The received data will be moved to the SPIR register as the shifting of the 8-bit data is completed. The RBF (Read Buffer Full) flag and the RBFi(Read Buffer Full Interrupt) flag are then set.
- SPIR reg.:Read buffer. The buffer will be updated as the 8-bit shifting is completed. The data must be read before the next reception is completed. The RBF flag is cleared as the SPIR register reads.
- SPIW reg.:Write buffer. The buffer will deny any attempt to write until the 8-bit shifting is completed.

The SSE bit will be kept in 1 if the communication is still undergoing. This flag must be cleared as the shifting is completed. Users can determine if the next write attempt is available.

- SBRS2~SBRS0:Programming the clock frequency/rates and sources.
- Clock Select:Selecting either the internal or external clock as the shifting clock.
- Edge Select:Selecting the appropriate clock edges by programming the CES bit

4.5.3 SPI Signal & Pin Description

The detailed functions of the four pins, SDI, SDO, SCK, and /SS, which are shown in Fig. 9, are as follows:

SDI/P92 (Pin 7):

- Serial Data In,
- Receive serially, the Most Significant Bit (MSB) first, Least Significant Bit (LSB) last,
- Defined as high-impedance, if not selected,
- Program the same clock rate and clock edge to latch on both the master and slave devices,



- The received byte will update the transmitted byte,
- Both the RBF and RBFIF bits (located in Register 0x0C) will be set as the SPI operation is completed.
- Timing is shown in Fig.13 and14.

SDO/P93 (Pin 8):

- Serial Data Out,
- Transmit serially; the Most Significant Bit (MSB) first, Least Significant Bit (LSB) last,
- Program the same clock rate and clock edge to latch on both the master and slave devices,
- The received byte will update the transmitted byte,
- The CES (located in Register 0x0D) bit will be reset, as the SPI operation is completed.
- Timing is shown in Fig.13 and 14.

SCK/P94 (Pin 9):

- Serial Clock
- Generated by a master device
- Synchronize the data communication on both the SDI and SDO pins
- The CES (located in Register 0x0D) is used to select the edge to communicate.
- The SBR0~SBR2 (located in Register 0x0D) is used to determine the baud rate of communication
- The CES, SBR0, SBR1, and SBR2 bits have no effect in the slave mode
- Timing is show in Fig.13 and 14

/SS/P95 (Pin 10):

- Slave Select; negative logic,
- Generated by a master device to signify the slave(s) to receive data,
- Goes low before the first cycle of SCK appears, and remains low until the last (eighth) cycle is completed,
- Ignores the data on the SDI and SDO pins while /SS is high, because the SDO is no longer driven.
- Timing is shown in Fig.13 and Fig. 14.



4.5.4 Programmed the related registers

As the SPI mode is defined, the related registers of this operation are shown in Table 2 and Table 3.

Table 2 Related Control Registers of the SPI Mode

Address	Name	Bit 7	Bit 6	Bit 5	Bit 4	Bit 3	Bit 2	Bit 1	Bit 0
0x0D	*SPIC/RD	CES	SPIE	SRO	SSE	--	SBR2	SBR1	SBR0
0x0F	INTC/IOCF	--	--	--	--	TM1IE	SPIIE	EXIE	TCIE

SPIC: SPI Control Register.

Bit 7 (CES): Clock Edge Select bit

0 = Data shifts out on rising edge, and shifts in on falling edge. Data is on hold during the low level.

1 = Data shifts out on falling edge, and shifts in on rising edge. Data is on hold during the high level.

Bit 6 (SPIE): SPI Enable bit

0 = Disable SPI mode

1 = Enable SPI mode

Bit 5 (SRO): SPI Read Overflow bit

0 = No overflow.

1 = A new data is received while the previous data is still being on hold in the SPIB register. Under this condition, the data in SPIS register will be destroyed. To avoid setting this bit, users should read the SPIRB register even if the transmission is implemented only.

NOTE

This can only occur under slave mode.

Bit 4 (SSE): SPI Shift Enable bit

0 = Reset as soon as the shifting is completed and the next byte is ready to shift.

1 = Start to shift, and stays on 1 while the current byte continues to transmit.

NOTE

This bit can be reset by hardware only.



Bit 2~0 (S BRS): SPI Baud Rate Select Bits

SBRS2 (Bit 2)	SBRS1 (Bit 1)	SBRS0 (Bit 0)	Mode	Baud Rate
0	0	0	Master	Fsco/2
0	0	1	Master	Fsco/4
0	1	0	Master	Fsco/8
0	1	1	Master	Fsco/16
1	0	0	Master	Fsco/32
1	0	1	Slave	/SS enable
1	1	0	Slave	/SS disable
1	1	1	Master	TMR1/2

NOTE
In master mode, /SS is disable.

INTC: Interrupt control register

Bit 3 (TM1IE) TM1IE interrupt enable bit.

- 0: disable TM1IE interrupt
- 1: enable TM1IE interrupt

Bit 2 (SPIIE) SPI interrupt enable bit.

- 0: disable SPI interrupt
- 1: enable SPI interrupt

Bit 1 (EXIE) EXIF interrupt enable bit.

- 0: disable EXIF interrupt
- 1: enable EXIF interrupt

Bit 0 (TCIE) TCIF interrupt enable bit.

- 0: disable TCIF interrupt
- 1: enable TCIF interrupt

Table 3 Related Status/Data Registers of the SPI Mode

Address	Name	Bit 7	Bit 6	Bit 5	Bit 4	Bit 3	Bit 2	Bit 1	Bit 0
0X0A	SPIRB/RA	SRB7	SRB6	SRB5	SRB4	SRB3	SRB2	SRB1	SRB0
0x0B	SPIWB/RB	SWB7	SWB6	SWB5	SWB4	SWB3	SWB2	SWB1	SWB0
0x0C	SPIS/RC	0	0	0	TM1IF	OD3	OD4	RBFIF	RBF

SPIRB: SPI Read Buffer. Once the serial data is received completely, it will load to SPIRB from SPISR. The RBF bit and the RBFIF bit in the SPIS register will be set also.

SPIWB: SPI Write Buffer. As a transmitted data is loaded, the SPIS register stands by and start to shift the data when sensing SCK edge with SSE set to "1".



SPIS: SPI Status register

Bit 4 (TM1IF):Timer1 interrupt flag.

Bit 3 (OD3)Open-Drain Control bit (P93)

0 = Open-drain disable for SDO.

1 = Open-drain enable for SDO,

Bit 2 (OD4):Open Drain-Control bit (P94)

0 = Open-drain disable for SCK.

1 = Open-drain enable for SCK

Bit 1 (RBFIF):Read Buffer Full Interrupt flag

1 = Receive is completed, SPIB is full, and an interrupt occurs if enabled.

0 = Receive is ongoing, SPIB is empty.

Bit 0 (RBF):Read Buffer Full flag

0 = Receive is ongoingt, SPIB is empty.

1 = Receive is completed, SPIB is full.

4.5.5 SPI Mode Timing

The edge of SCK is selected by programming bit CES. The waveform shown in Fig.13 is applicable regardless of whether the EM78P451S is under master or slave mode with /SS disabled. However, The waveform in Fig. 14 can only be implemented in slave mode with /SS enabled.

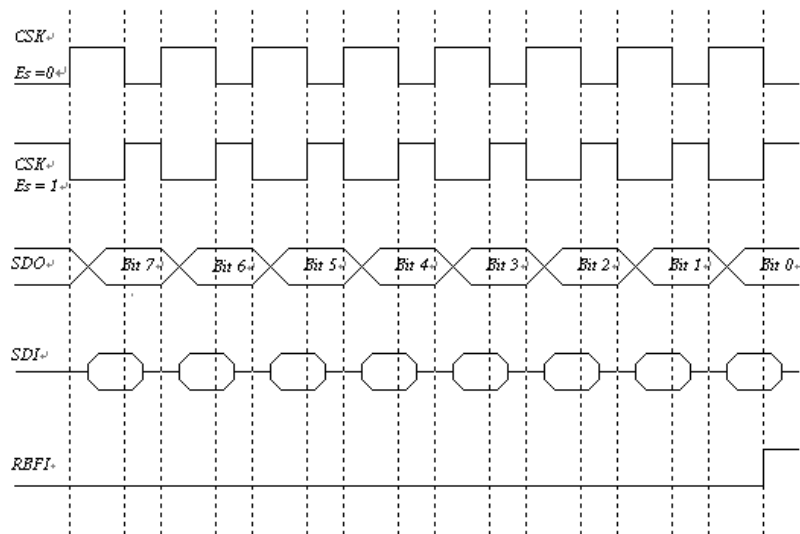

Fig. 13 SPI Mode with /SS Disable

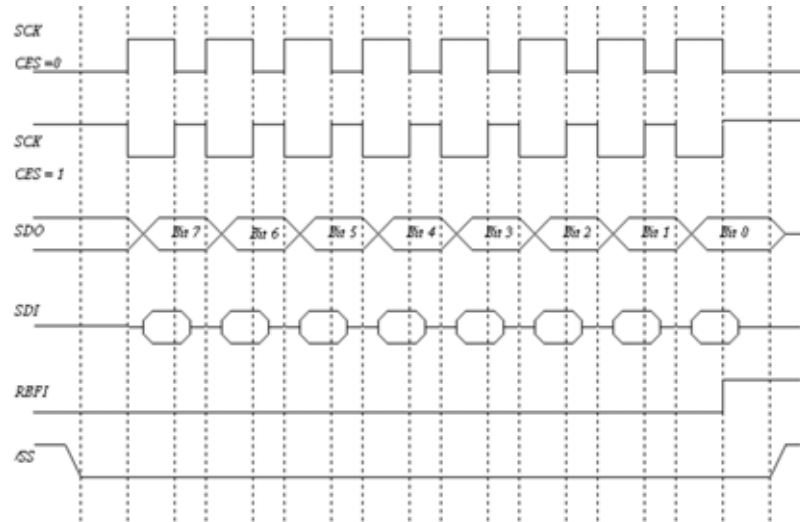

Fig. 14 SPI Mode with /SS Enable

4.5.6 Software Application of SPI

Example for SPI:

For Master

ORG 0X0

SETTING:

CLRA

IOW 0X05 ;Set Port5 output

IOW 0X06 ;Set Port6 output

MOV 0X05,A

MOV A,@0B11001111 ;Set prescaler for WDT

CONTW

MOV A,@0B00010001 ;Disable wakeup function

IOW 0X0E

MOV A,@0B00000000 ;Disable interrupt

IOW 0X0F

MOV A,@0x07 ;SDI input and SDO, SCK output

IOW 0x09

MOV A,@0B10000000 ;Clear RBF and RBFIF flag



```
MOV 0x0C,A
MOV A,@0B11100000 ;Select clock edge and enable SPI
MOV 0X0D,A
START:
WDTC
BC 0X0C,1 ;Clear RBFIF flag
MOV A,@0XFF
MOV 0X05,A ;Show a signal at Port5
MOV 0X0A,A ;Move FF at read buffer
MOV A,@0XAA ;Move AA at write buffer
MOV 0X0B,A
BS 0X0D,4 ;Start to shift SPI data
NOP
JBC 0X0D,4 ;Polling loop for checking SPI transmission completed
JMP $-2
BC 0X03,2
CALL DELAY ;To catch the data from slaver
MOV A,0X0A
XOR A,@0X5A ;Compare the data from slaver
JBS 0X03,2
JMP START
FLAG:
MOV A,@0X55 ;Show the signal when receiving correct data from slaver
MOV 0X05,A
CALL DELAY
JMP START
DELAY:
; (user's program)
EOP
ORG 0XFFF
JMP SETTING
```



```
For Slaver
ORG 0X0
INITI:
JMP INIT
ORG 0X2
INTERRUPT:           ;Interrupt address
MOV A,@0X55
MOV 0X06,A           ;Show a signal at Port 6 when entering interrupt
MOV A,@0B11100110    ;Enable SPI, /SS disabled
MOV 0X0D,A
BS 0X0D,4             ;Keep SSE at 1 to wait for SCK signal in order to shift data
MOV A,@0X00           ;Move 00 to write buffer in order to keep master's read buffer
as 00
MOV 0X0B,A
BS 0X0D,4             ;Keep SSE at 1 to wait for SCK signal in order to shift data
NOP
JBC 0X0D,4           ;Polling loop for checking SPI transmission completed
JMP $-2
BS 0X0D,4             ;Keep SSE at 1 to wait for SCK signal in order to shift data
BC 0X03,2
MOV A,0X0A
MOV 0X06,A           ;Read master's data from read buffer
XOR A,@0XAA          ;Check pass signal from read buffer
JBS 0X03,2
JMP $-6
JMP SPI

ORG 0X30
INIT:
CLRA
IOW 0X05
IOW 0X06
```



```
MOV 0x05,A
MOV 0X06,A
MOV A,@0XFF
IOW 0X08
MOV A,@0B11001111 ;Set prescaler for WDT
CONTW
MOV A,@0B00010001 ;Disable wakeup function
IOW 0X0E
MOV A,@0B00000010 ;Enable external interrupt
IOW 0XF
ENI
MOV A,@0B00110111
IOW 0x09
BC 0X3F,1 ;Clear RBFIF flag
NOP
JBS 0X3F,1 ;Polling loop for checking interrupt occurrence
JMP $-2
JMP INTERRUPT
SPI:
BS 0X0D,4 ;Keep SSE enabled as long as possible
WDTC
MOV A,@0X0F ;Show a signal when entering SPI loop
MOV 0X06,A
JBC 0X08,1 ;Choose P81 as a signal button
JMP SPI
MOV A,@0X5A ;Move 5A into write buffer when P81 button is pushed
MOV 0X0B,A
NOP
JBC 0X0D,4 ;Polling loop for checking SPI transmission completed
JMP $-2
BS 0XD,4
```



```
NOP
NOP
MOV A,@0XF0      ;Display at Port6 when P81 button is pushed
MOV 0X06,A
MOV A,@0X00      ;Send a signal to master to prevent infinite loop
MOV 0X0B,A
NOP
JBC 0X0D,4
JMP $-2
BS 0X0D,4
BS 0x0C,7
BC 0x0C,1
NOP
JMP SPI
DELAY:
                ; (user's program)

EOP
ORG 0XFFF
JMP INITI
```



4.6 Timer 1

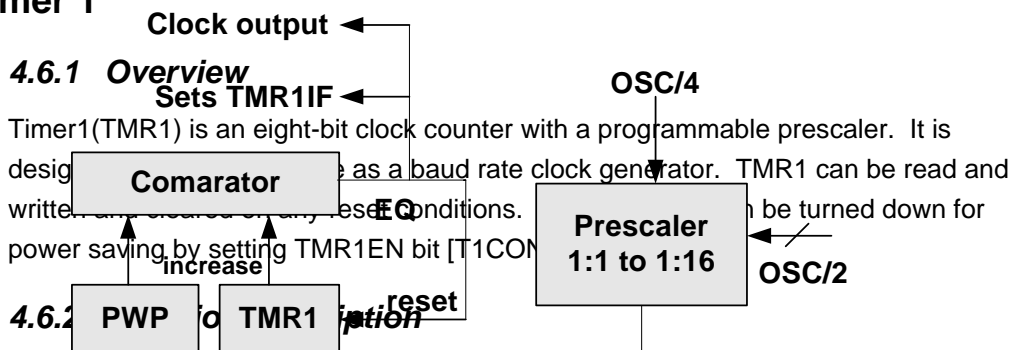

Fig. 15 shows TIMER1 block diagram. Each signal and block is described as follows:

Fig. 15 TIMER1 Block Diagram

- OSC/4:Input clock.
- Prescaler: Option of 1:1, 1:4, 1:8, and 1:16 defined by T1P1 and T1P02 (T1CON<1, 0>). It is cleared when a value is written to TMR1 or T1CON, and during any kind of reset as well.
- PWP: Pulse width preset register. The desired width of baud clock is written in advance.
- TMR1: Timer 1 register. TMR1 increases until it matches with PWP, and then resets to 0. If it is chosen optionally in the SPI mode, its output is fed as a shifting clock.
- Comarator: To change the output status while a match occurs. The TMR1IF flag will be set at the same time.

4.6.3 Programmed the related registers

The related registers of the defining TMR1 operation are shown in Table 4 and Table 5

Table 4 Related Control Registers of the TMR1

Address	Name	Bit 7	Bit 6	Bit 5	Bit 4	Bit 3	Bit 2	Bit 1	Bit 0
0x0C	SPIS/RC	0	0	0	TM1IF	OD3	OD4	RBFIF	RBF
0x0F	INTC/IOCF	0	0	0	0	TM1IE	SPIIE	EXIE	TCIE

Table 5 Related Status/Data Registers ofTMR1

Address	Name	Bit 7	Bit 6	Bit 5	Bit 4	Bit 3	Bit 2	Bit 1	Bit 0
0X0E	TMR1/RE	TMR17	TMR16	TMR15	TMR14	TMR13	TMR12	TMR11	TMR10
0x0F	PWP/RF	PWP7	PWP6	PWP5	PWP4	PWP3	PWP2	PWP1	PWP0
0x0C	T1CON/IOCC	0	0	0	0	0	TM1E	TM1P1	TM1P0

- TMR1: Timer1 Register
TMR17~TMR10 is bit set of Timer1 register and it increases until the value matches PWP and then it reset to 0.
- PWP: Pulse Width Preset Register
PWP7~PWP0 is bit set of pulse width preset for the desired width of baud clock in advance.
- T1CON: Timer1 Control Register
Bit 2 (TM1E): Timer1 enable bit
Bit 1 (TM1P1) and Bit 0 (TM1P): Timer1 prescaler for FSCO

TM1P1	TM1P0	Prescaler Rate
0	0	1:1
0	1	1:4
1	0	1:8
1	1	1:16

4.7 RESET and Wake-up

A RESET is initiated by

- (1) Power on reset, or
- (2) /RESET pin input "low", or
- (3) WDT timeout. (if enabled)

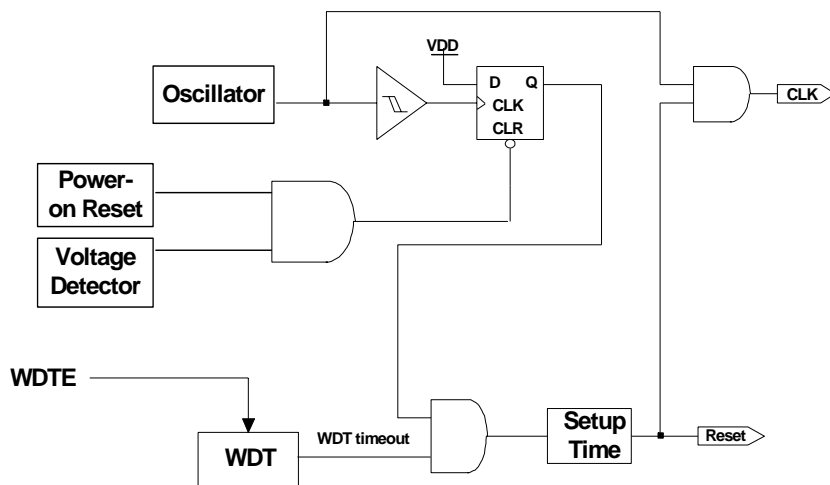

Fig. 16 Block Diagram of Reset



EM78P451S POR voltage range is 1.2V~2.0V. Under customer application, when power is OFF, V_{dd} must drop to below 1.2V and remains OFF for 10 μ s before power can be switched ON again. This way, the EM78P451S will reset and work normally. The extra external reset circuit will work well if V_{dd} can rise at very fast speed (50 ms or less). However, under most cases where critical applications are involved, extra devices are required to assist in solving the power-up problem.

The device is kept in a RESET condition for a period of approx. 18ms² (one oscillator start-up timer period) after the reset is detected and Fig.16 is the block diagram of reset. Once the RESET occurs, the following functions are performed.

- The oscillator is running, or will be started.
- The Program Counter (R2) is set to all "1".
- When power is switched on, bits 5~6 of R3 and the upper 2 bits of R4 are cleared.
- All I/O port pins are configured as input mode (high-impedance state).
- The Watchdog timer and prescaler are cleared.
- The Watchdog timer is enabled if Code Option bit ENWDT is "1".
- The CONT register is set to all "1" except bit 6 (INT flag).
- Bits 3,6 of IOCE register are cleared, bits 0,4~5 of IOCE register are set to "1".
- Bits 0 of R3F and bits 0 of IOCF registers are cleared.

The sleep mode (power down) is achieved by executing the SLEEP instruction (named as SLEEP1 MODE). While entering sleep mode, the WDT (if enabled) is cleared but keeps on running. The controller is awakened by WDT timeout (if enabled), and it will cause the controller to reset. The T and P flags of R3 are used to determine the source of the reset (wake-up).

In addition to the basic SLEEP1 MODE, EM78P451S has another sleep mode (caused by clearing "SLPC" bit of IOCE register, designated as SLEEP2 MODE). In the SLEEP2 MODE, the controller can be awakened by-

- (a) Any one of the wake-up pins is set to "0." (refer to Fig.17). Upon waking, the controller will continue to execute the program in-line. In this case, before entering SLEEP2 MODE, the wake-up function of the trigger sources (P60~P67, P74~P75, and P90~P91) should be selected (e.g. input pin) and enabled (e.g. pull-high, wake-up control). One caution should be noted is that after waking up, the WDT is enabled if Code Option bit ENWDT is "1". The WDT operation (to be enabled or disabled) should be appropriately controlled by software after waking up.
- (b) WDT time-out (if enabled). or external reset input on /RESET pin will trigger a controller reset..

² NOTE: V_{dd} = 5V, set up time period = 16.20ms \pm 30%
V_{dd} = 3V, set up time period = 18.0ms \pm 30%



Table 6 Usage of Sleep and Sleep2 Mode

Usage of Sleep and Sleep2 Mode	
SLEEP2	SLEEP
(a) Before SLEEP 1. Set Port6 or P74 or P75 Input 2. Enable Pull-High and set WDT prescaler over 1:1 (Set CONT.7 and CONT.3 ~ CONT.0) 3. Enable Wake-up (Set IOCB or IOCE.0) 4. Execute Seep2 (Set IOCE.4) (b) After Wake-up 1. Next instruction 2. Disable Wake-up 3. Disable WDT (Set IOCE.5)	(a) Before SLEEP 1. Execute SLEP instruction (b) After Wake-up 1. Reset

If Port6 Input Status Changed Wake-up is used to wake-up the EM78P451S (Case [a] above), the following instructions must be executed before entering SLEEP2 mode:

```

MOV      A, @11111111b          ; Set Port6 input
IOW
MOV      A, @0xxx1010b        ; Set Port6 pull-high, WDT prescaler, prescaler must set over 1:1
CONTW
MOV      A, @xx00xx0b         ; Enable Port6 wake-up function, Enable SLEEP2
IOW
  
```

After Wake-up

```

NOP
MOV      A, @ xx01xxx1b       ; Disable Port6 wake-up function; Disable WDT
IOW
  
```

After waking up from the SLEEP2 mode, WDT is automatically enabled. The WDT enabled/disabled operation after waking up from SLEEP2 mode should be appropriately defined in the software.

To avoid a reset from occurring when the Port 6 Input Status Changed Interrupt enters into interrupt vector or is used to wake-up the MCU, the WDT prescaler must be set above the 1:1 ratio.

Table 7 The Summary of the Initialized Values for Registers

Address	Name	Reset Type	Bit 7	Bit 6	Bit 5	Bit 4	Bit 3	Bit 2	Bit 1	Bit 0
N/A	IOC5	Bit Name	C57	C56	C55	C54	C53	C52	C51	C50
		Power-On	1	1	1	1	1	1	1	1
		/RESET and WDT	1	1	1	1	1	1	1	1
		Wake-Up from Pin Change	P	P	P	P	P	P	P	P
N/A	IOC6	Bit Name	C67	C66	C65	C64	C63	C62	C61	C60
		Power-On	1	1	1	1	1	1	1	1
		/RESET and WDT	1	1	1	1	1	1	1	1
		Wake-Up from Pin Change	P	P	P	P	P	P	P	P
N/A	IOC7	Bit Name	C77	C76	C75	C74	C73	C72	C71	C70
		Power-On	1	1	1	1	1	1	1	1
		/RESET and WDT	1	1	1	1	1	1	1	1
		Wake-Up from Pin Change	P	P	P	P	P	P	P	P
N/A	IOC8	Bit Name	C87	C86	C85	C84	C83	C82	C81	C80
		Power-On	1	1	1	1	1	1	1	1
		/RESET and WDT	1	1	1	1	1	1	1	1



Address	Name	Reset Type	Bit 7	Bit 6	Bit 5	Bit 4	Bit 3	Bit 2	Bit 1	Bit 0
		Wake-Up from Pin Change	P	P	P	P	P	P	P	P
N/A	IOC9	Bit Name	C97	C96	C95	C94	C93	C92	C91	C90
		Power-On	1	1	1	1	1	1	1	1
		/RESET and WDT	1	1	1	1	1	1	1	1
		Wake-Up from Pin Change	P	P	P	P	P	P	P	P
N/A	CONT	Bit Name	/PHE N	/INT	-	-	PAB	PSR 2	PSR 1	PSR 0
		Power-On	1	0	1	1	1	1	1	1
		/RESET and WDT	1	P	1	1	1	1	1	1
		Wake-Up from Pin Change	P	P	P	P	P	P	P	P
0x00	R0(IAR)	Bit Name	-	-	-	-	-	-	-	-
		Power-On	U	U	U	U	U	U	U	U
		/RESET and WDT	P	P	P	P	P	P	P	P
		Wake-Up from Pin Change	P	P	P	P	P	P	P	P
0x01	R1(TCC)	Bit Name	-	-	-	-	-	-	-	-
		Power-On	0	0	0	0	0	0	0	0
		/RESET and WDT	0	0	0	0	0	0	0	0
		Wake-Up from Pin Change	P	P	P	P	P	P	P	P
0x02	R2(PC)	Bit Name	-	-	-	-	-	-	-	-
		Power-On	1	1	1	1	1	1	1	1
		/RESET and WDT	1	1	1	1	1	1	1	1
		Wake-Up from Pin Change	**P	**P	**P	**P	**P	**P	**P	**P
0x03	R3(SR)	Bit Name	GP	PS1	PS0	T	P	Z	DC	C
		Power-On	0	0	0	t	t	U	U	U
		/RESET and WDT	0	0	0	t	t	P	P	P
		Wake-Up from Pin Change	P	P	P	t	t	P	P	P
0x04	R4(RSR)	Bit Name	RSR. 1	RSR. 0	-	-	-	-	-	-
		Power-On	0	0	U	U	U	U	U	U
		/RESET and WDT	0	0	P	P	P	P	P	P
		Wake-Up from Pin Change	P	P	P	P	P	P	P	P
0x05	R5(P5)	Bit Name	P57	P56	P55	P54	P53	P52	P51	P50
		Power-On	U	U	U	U	U	U	U	U
		/RESET and WDT	P	P	P	P	P	P	P	P
		Wake-Up from Pin Change	P	P	P	P	P	P	P	P
0x06	R6(P6)	Bit Name	P67	P66	P65	P64	P63	P62	P61	P60
		Power-On	U	U	U	U	U	U	U	U
		/RESET and WDT	P	P	P	P	P	P	P	P
		Wake-Up from Pin Change	P	P	P	P	P	P	P	P
0x07	R7(P7)	Bit Name	P77	P76	P75	P74	P73	P72	P71	P70
		Power-On	U	U	U	U	U	U	U	U
		/RESET and WDT	P	P	P	P	P	P	P	P
		Wake-Up from Pin Change	P	P	P	P	P	P	P	P
0x08	R8(P8)	Bit Name	P87	P86	P85	P84	P83	P82	P81	P80
		Power-On	U	U	U	U	U	U	U	U
		/RESET and WDT	P	P	P	P	P	P	P	P



Address	Name	Reset Type	Bit 7	Bit 6	Bit 5	Bit 4	Bit 3	Bit 2	Bit 1	Bit 0
		Wake-Up from Pin Change	P	P	P	P	P	P	P	P
0x09	R9(P9)	Bit Name	P97	P96	P95	P94	P93	P92	P91	P90
		Power-On	U	U	U	U	U	U	U	U
		/RESET and WDT	P	P	P	P	P	P	P	P
		Wake-Up from Pin Change	P	P	P	P	P	P	P	P
0x0A	RA(SPIRB)	Bit Name	SRB ₇	SRB ₆	SRB ₅	SRB ₄	SRB ₃	SRB ₂	SRB ₁	SRB ₀
		Power-On	U	U	U	U	U	U	U	U
		/RESET and WDT	P	P	P	P	P	P	P	P
		Wake-Up from Pin Change	P	P	P	P	P	P	P	P
0x0B	RB(SPIWB)	Bit Name	SWB ₇	SWB ₆	SWB ₅	SWB ₄	SWB ₃	SWB ₂	SWB ₁	SWB ₀
		Power-On	U	U	U	U	U	U	U	U
		/RESET and WDT	P	P	P	P	P	P	P	P
		Wake-Up from Pin Change	P	P	P	P	P	P	P	P
0x0C	RC(SPIS)	Bit Name	ENS DO	OBD C	IBDC	TIIF	OD3	OD4	RBFI F	RBF
		Power-On	0	0	0	0	0	0	0	0
		/RESET and WDT	0	0	0	0	0	0	0	0
		Wake-Up from Pin Change	P	P	P	P	P	P	P	P
0x0D	RD(SPIC)	Bit Name	CES	SPIE	SRO	SPIS E	-	SBR S2	SBR S1	SBR S0
		Power-On	0	0	0	0	0	0	0	0
		/RESET and WDT	0	0	0	0	0	0	0	0
		Wake-Up from Pin Change	P	P	P	P	P	P	P	P
0x0E	RE(TMR1)	Bit Name	TMR 17	TMR 16	TMR 15	TMR 14	TMR 13	TMR 12	TMR 11	TMR 10
		Power-On	0	0	0	0	0	0	0	0
		/RESET and WDT	0	0	0	0	0	0	0	0
		Wake-Up from Pin Change	P	P	P	P	P	P	P	P
0x0F	RF(PWP)	Bit Name	PWP 7	PWP 6	PWP 5	PWP 4	PWP 3	PWP 2	PWP 1	PWP 0
		Power-On	1	1	1	1	1	1	1	1
		/RESET and WDT	1	1	1	1	1	1	1	1
		Wake-Up from Pin Change	P	P	P	P	P	P	P	P
0x3F	R3F(ISR)	Bit Name	-	-	-	-	T1IF	SPIIF	EXIF	TCIF
		Power-On	U	U	U	U	0	0	0	0
		/RESET and WDT	U	U	U	U	0	0	0	0
		Wake-Up from Pin Change	U	U	U	U	P	P	P	P
0x0C	IOCC	Bit Name	-	-	-	-	-	T1E	T1P1	T1P0
		Power-On	0	0	0	0	0	0	0	0
		/RESET and WDT	0	0	0	0	0	0	0	0
		Wake-Up from Pin Change	P	P	P	P	P	P	P	P
0x0D	IOCD	Bit Name	S7	-	-	-	/PU9	/PU8	/PU6	/PU5
		Power-On	1	1	1	1	1	1	1	1
		/RESET and WDT	1	1	1	1	1	1	1	1



Address	Name	Reset Type	Bit 7	Bit 6	Bit 5	Bit 4	Bit 3	Bit 2	Bit 1	Bit 0
		Wake-Up from Pin Change	P	P	P	P	P	P	P	P
0x0E	IOCE	Bit Name	-	ODE	WTE	SLP C	ROC	-	-	/WU E
		Power-On	U	0	1	1	0	U	U	1
		/RESET and WDT	U	0	1	1	0	U	U	1
		Wake-Up from Pin Change	U	P	1	1	P	U	U	P
0x0F	IOCF	Bit Name	-	-	-	-	T1IE	SPII E	EXIE	TCIE
		Power-On	U	U	U	U	0	0	0	0
		/RESET and WDT	U	U	U	U	0	0	0	0
		Wake-Up from Pin Change	U	U	U	U	P	P	P	P
0x10~0x3E	GPR	Bit Name	-	-	-	-	-	-	-	-
		Power-On	U	U	U	U	U	U	U	U
		/RESET and WDT	P	P	P	P	P	P	P	P
		Wake-Up from Pin Change	P	P	P	P	P	P	P	P

** To execute the next instruction after the "SLPC" bit status of IOCE register being on high-to-low transition.

X: NOTE

*used. U: Unknown or don't care. -: Not defined P: Previous value before reset.
t: Check Table 7*

The Status of RST, T, and P of STATUS Register

A RESET condition is initiated by the following events:

1. A power-on condition,
2. Watchdog timer time-out.

The values of T and P, listed in Table 7 are used to check how the processor wakes up.

Table 8 shows the events that may affect the status of T and P.

Table 8 The Values of RST, T and P After RESET

Reset Type	T	P
Power on	1	1
WDT during Operating mode	0	P
WDT wake-up during SLEEP1 mode	0	0
WDT wake-up during SLEEP2 mode	0	P
Wake-Up on pin change during SLEEP2 mode	P	P

* P: Previous value before reset



Table 9 The Status of RST, T and P Being Affected by Events

Event	T	P
Power on	1	1
WDTC instruction	1	1
WDT time-out	0	*P
SLEEP instruction	1	0
Wake-Up on pin change during SLEEP2 mode	P	P

* P: Previous value before reset

4.8 Interrupt

The EM78P451S has the following interrupts.

1. /TCC overflow interrupt
2. External interrupt (/INT)
3. Serial Peripheral Interface (SPI) transmission completed interrupt.
4. Timer1 comparator completed interrupt.

R3F is the interrupt status register, which records the interrupt request in flag bit. IOCF is the interrupt mask register. Global interrupt is enabled by ENI instruction and is disabled by DISI instruction. When one of the interrupts (if enabled) is generated, will cause the next instruction to be fetched from address 001H. Once in the interrupt service routine the source of the interrupt can be determined by polling the flag bits in the R3F register. The interrupt flag bit must be cleared by software before leaving the interrupt service routine and enabling interrupts to avoid recursive interrupts.

The flag in the Interrupt Status Register (R3F) is set regardless of the status of its mask bit or the execution of ENI instruction. Note that reading R3F will obtain the output of logic AND of R3F and IOCF (refer to Fig. 17). The RETI instruction exits interrupt routine and enables the global interrupt (execution of ENI instruction).

When an interrupt is generated by INT instruction (if enabled), it causes the next instruction to be fetched from address 002H.

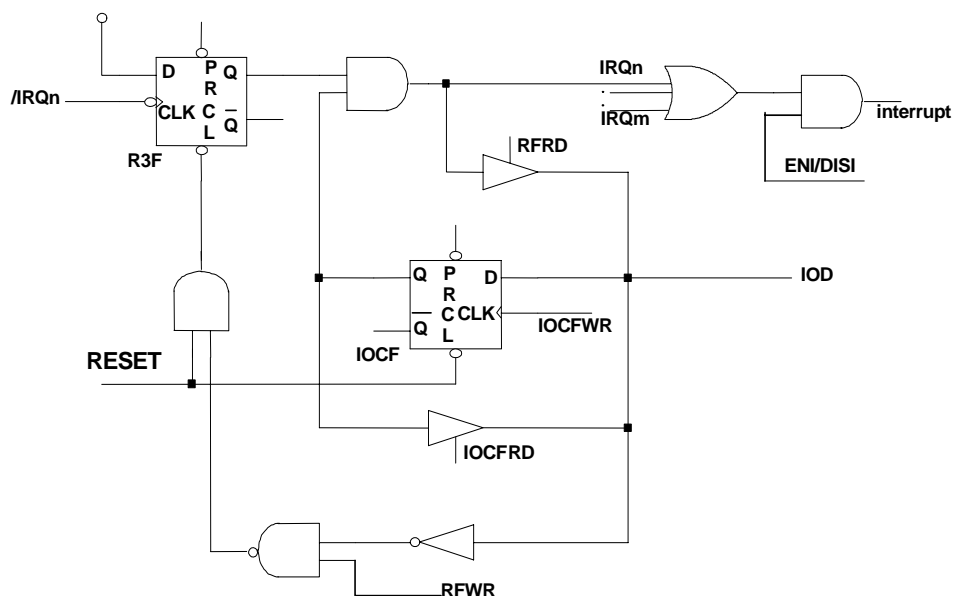

Fig. 17 Interrupt Input Circuit

4.9 Oscillator

4.9.1 Oscillator Modes

The EM78P451S can operate in four different oscillator modes. There are high XTAL (HXT) oscillator mode, low XTAL (LXT) oscillator mode, External RC oscillator mode (ERC), and Internal C、 External R oscillator modes. User can select one of them by programming MS, RCT, HLF and HLP in the Code Option Register. Table 9 depicts how these three modes are defined.

Table 10 Oscillator Modes by MS, IRC, RCT.

Mode	MS	RCT	HLF	HLP
High XTAL Oscillator	1	X	1	X
Low XTAL Oscillator	1	X	0	0
External RC Oscillator	0	1	X	X
External R and Internal C Oscillator	0	0	X	X

<Note> X: Don't care

4.9.2 Crystal Oscillator/Ceramic Resonators (XTAL)

EM78P451S can be driven by an external clock signal through the OSCI pin as shown in Fig 18 below. In the most applications, pin OSCI and pin OSCO is connected with a crystal or ceramic resonator to generate oscillation. Fig 19 depicts such circuit. Table 10 provides the recommended values of C1 and C2. Since each resonator has its own attribute, user should refer to its specification for appropriate values of C1 and C2. RS, a serial resistor may be necessary for AT strip cut crystal or low frequency mode.

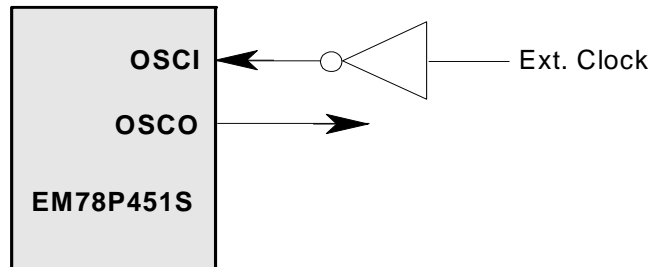

Fig. 18 Circuit for External Clock Input

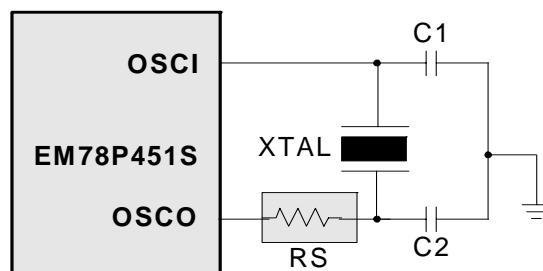

Fig. 19 Circuit for Crystal/Resonator

Table 11 Capacitor Selection Guide for Crystal Oscillator Ceramic Resonators

Oscillator Type	Frequency Mode	Frequency	C1 (pF)	C2 (pF)
Ceramic Resonator	HXT	455 KHz	10~150	10~150
		1.0 MHz	40~80	40~80
		2.0 MHz	20~40	20~40
		4.0 MHz	10~30	10~30
Crystal Oscillator	LXT	32.768 KHz	25	15
		100 KHz	25	25
		200 KHz	25	25
	HXT	455 KHz	20~40	20~150
		1.0 MHz	15~30	15~30
		2.0 MHz	15	15
		4.0 MHz	15	15

4.9.3 RC Oscillator Mode

For some applications that do not need a very precise timing calculation, the RC oscillator (Fig 22 & Fig 23) offers a lot of cost savings. Nevertheless, it should be noted that the frequency of the RC oscillator is influenced by the supply voltage, the values of the resistor (R_{ext}), the capacitor (C_{ext}), and even by the operation temperature. Moreover, the frequency also changes slightly from one chip to another due to the manufacturing process variation.

In order to maintain a stable system frequency, the values of the C_{ext} should not be less than 20pF, and that the value of R_{ext} should not be greater than 1 M ohm. If they cannot be kept in this range, the frequency is easily affected by noise, humidity, and leakage.

The smaller the R_{ext} in the RC oscillator, the faster its frequency will be. On the contrary, for very low R_{ext} values, for instance, 1 K Ω , the oscillator becomes unstable because the NMOS cannot discharge the current of the capacitance correctly.

Based on the reasons above, it must be kept in mind that all of the supply voltage, the operation temperature, the components of the RC oscillator, the package types, the way the PCB is layout, will affect the system frequency.

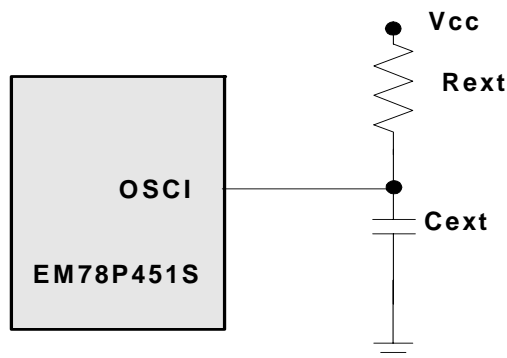

Fig. 20 Circuit for External RC Oscillator Mode

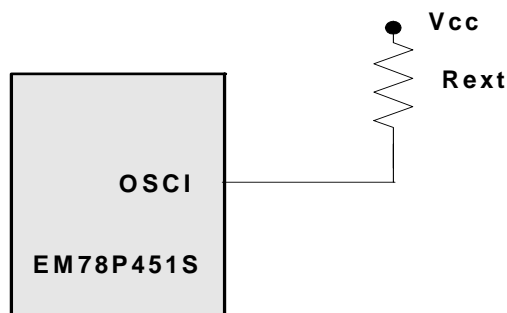

Fig. 21 Circuit for External R, Internal C Oscillator Mode



Calibrate frequency of External RC oscillator (For reference only)

C ext	R ext	Fosc @5.0V,25
20pF	3.3K	3.4MHz
	5.1K	2.2MHz
	10K	1.3MHz
	100K	144KHz
100pF	3.3K	1.2MHz
	5.1K	935KHz
	10K	420KHz
	100K	45KHz
300pF	3.3K	550KHz
	5.1K	360KHz
	10K	190KHz
	100K	28KHz

Internal C, external R Table (For reference only)

External R (Ohm)	Fosc @5.0V, 25 (Hz)
10K	12M
15K	7.7M
20K	5.7M
30K	3.65M
51K	2.24M
100K	1.14M
150K	749K
200K	559K
510K	214K
2M	56K
3.3M	32.8K

4.10 Code Option Register

WORD 0

12	11	10	9	8	7	6	5	4	3	2	1	0
MS	ENWDT	CLKS	PTB	HLF	RCT	HLP	DEL1	DEL0	REN	N/A	N/A	N/A

Bit 12 (MS): Oscillator type selection.

- 0: RC type
- 1: XTAL type

Bit 11 (ENWDT): Watchdog Timer enabled.

- 0: Enable
- 1: Disable

Bit 10 (CLKS): Clocks of each instruction cycle.

- 0: Two clocks
- 1: Four clocks



Bit 9 (PTB): Protect bit.

0: Protect enabled

1: Protect disabled

Bit 8 (HLF): XTAL frequency selection.

0: Low frequency (32.768KHz)

1: High frequency

This bit is useful only when Bit 12 (MS) is 1. When MS is 0, HLF must be 0.

Bit 7 (RCT): Resistor Capacitor.

0: internal RC

1: external RC

Bit 6 (HLP): Power consumption selection.

0: Low power

1: High power

Bit 5 ~ Bit 4: DEL1 and DEL0 (SDI) input delay time options.

DEL 1	DEL 0	Delay time
1	1	0 ns
0	1	50 ns
1	0	100 ns

Bit3~0 (REN): reset pin enable bit

0: enable, P70/reset=>reset pin

1: disable, P70/reset=> P70

WORD 1 (user's ID code)

12	11	10	9	8	7	6	5	4	3	2	1	0
ID12	ID11	ID10	ID9	ID8	ID7	ID6	ID5	ID4	ID3	ID2	ID1	ID0

4.11 Instruction Set

Each instruction in the instruction set is a 13-bit word divided into an OP code and one or more operands. All instructions are executed within one single instruction cycle (consisting of 2 oscillator periods), unless the program counter is changed by-

- (a) Executing the instruction "MOV R2,A", "ADD R2,A", "TBL", or any other instructions that write to R2 (e.g. "SUB R2,A", "BS R2,6", "CLR R2", ...).
- (b) execute CALL, RET, RETI, RETL, JMP, Conditional skip (JBS, JBC, JZ, JZA, DJZ, DJZA) which were tested to be true.

Under these cases, the execution takes two instruction cycles.

In addition, the instruction set has the following features:



- (1). Every bit of any register can be set, cleared, or tested directly.
- (2). The I/O register can be regarded as general register. That is, the same instruction can operate on I/O register.

The symbol "R" represents a register designator that specifies which one of the registers (including operational registers and general purpose registers) is to be utilized by the instruction. Bits 6 and 7 in R4 determine the selected register bank. "b" represents a bit field designator that selects the value for the bit located in the register "R" and affects operation. "k" represents an 8 or 10-bit constant or literal value.

INSTRUCTION BINARY	HEX	MNEMONIC	OPERATION	STATUS AFFECTED
0 0000 0000 0000	0000	NOP	No Operation	None
0 0000 0000 0001	0001	DAA	Decimal Adjust A	C
0 0000 0000 0010	0002	CONTW	A → CONT	None
0 0000 0000 0011	0003	SLEP	0 → WDT, Stop oscillator	T,P
0 0000 0000 0100	0004	WDTC	0 → WDT	T,P
0 0000 0000 rrrr	000r	IOW R	A → IOCR	None <Note1>
0 0000 0001 0000	0010	ENI	Enable Interrupt	None
0 0000 0001 0001	0011	DISI	Disable Interrupt	None
0 0000 0001 0010	0012	RET	[Top of Stack] → PC	None
0 0000 0001 0011	0013	RETI	[Top of Stack] → PC, Enable Interrupt	None
0 0000 0001 0100	0014	CONTR	CONT → A	None
0 0000 0001 rrrr	001r	IOR R	IOCR → A	None <Note1>
0 0000 0010 0000	0020	TBL	R2+A → R2, Bits 8~9 of R2 unchanged	Z,C,DC
0 0000 01rr rrrr	00rr	MOV R,A	A → R	None
0 0000 1000 0000	0080	CLRA	0 → A	Z
0 0000 11rr rrrr	00rr	CLR R	0 → R	Z
0 0001 00rr rrrr	01rr	SUB A,R	R-A → A	Z,C,DC
0 0001 01rr rrrr	01rr	SUB R,A	R-A → R	Z,C,DC
0 0001 10rr rrrr	01rr	DECA R	R-1 → A	Z
0 0001 11rr rrrr	01rr	DEC R	R-1 → R	Z
0 0010 00rr rrrr	02rr	OR A,R	A ∨ VR → A	Z
0 0010 01rr rrrr	02rr	OR R,A	A ∨ VR → R	Z
0 0010 10rr rrrr	02rr	AND A,R	A & R → A	Z
0 0010 11rr rrrr	02rr	AND R,A	A & R → R	Z
0 0011 00rr rrrr	03rr	XOR A,R	A ⊕ R → A	Z
0 0011 01rr rrrr	03rr	XOR R,A	A ⊕ R → R	Z
0 0011 10rr rrrr	03rr	ADD A,R	A + R → A	Z,C,DC
0 0011 11rr rrrr	03rr	ADD R,A	A + R → R	Z,C,DC
0 0100 00rr rrrr	04rr	MOV A,R	R → A	Z
0 0100 01rr rrrr	04rr	MOV R,R	R → R	Z
0 0100 10rr rrrr	04rr	COMA R	/R → A	Z



INSTRUCTION BINARY	HEX	MNEMONIC	OPERATION	STATUS AFFECTED
0 0100 11rr rrrr	04rr	COM R	/R → R	Z
0 0101 00rr rrrr	05rr	INCA R	R+1 → A	Z
0 0101 01rr rrrr	05rr	INC R	R+1 → R	Z
0 0101 10rr rrrr	05rr	DJZA R	R-1 → A, skip if zero	None
0 0101 11rr rrrr	05rr	DJZ R	R-1 → R, skip if zero	None
0 0110 00rr rrrr	06rr	RRCA R	R(n) → A(n-1), R(0) → C, C → A(7)	C
0 0110 01rr rrrr	06rr	RRC R	R(n) → R(n-1), R(0) → C, C → R(7)	C
0 0110 10rr rrrr	06rr	RLCA R	R(n) → A(n+1), R(7) → C, C → A(0)	C
0 0110 11rr rrrr	06rr	RLC R	R(n) → R(n+1), R(7) → C, C → R(0)	C
0 0111 00rr rrrr	07rr	SWAPA R	R(0-3) → A(4-7), R(4-7) → A(0-3)	None
0 0111 01rr rrrr	07rr	SWAP R	R(0-3) ↔ R(4-7)	None
0 0111 10rr rrrr	07rr	JZA R	R+1 → A, skip if zero	None
0 0111 11rr rrrr	07rr	JZ R	R+1 → R, skip if zero	None
0 100b bbrr rrrr	0xxx	BC R,b	0 → R(b)	None <Note2>
0 101b bbrr rrrr	0xxx	BS R,b	1 → R(b)	None <Note3>
0 110b bbrr rrrr	0xxx	JBC R,b	if R(b)=0, skip	None
0 111b bbrr rrrr	0xxx	JBS R,b	if R(b)=1, skip	None
1 00kk kkkk kkkk	1kkk	CALL k	PC+1 → [SP], (Page, k) → PC	None
1 01kk kkkk kkkk	1kkk	JMP k	(Page, k) → PC	None
1 1000 kkkk kkkk	18kk	MOV A,k	k → A	None
1 1001 kkkk kkkk	19kk	OR A,k	A ∨ k → A	Z
1 1010 kkkk kkkk	1Akk	AND A,k	A & k → A	Z
1 1011 kkkk kkkk	1Bkk	XOR A,k	A ⊕ k → A	Z
1 1100 kkkk kkkk	1Ckk	RETL k	k → A, [Top of Stack] → PC	None
1 1101 kkkk kkkk	1Dkk	SUB A,k	k-A → A	Z,C,DC
1 1110 0000 0010	1E02	INT	PC+1 → [SP], 002H → PC	None
1 1111 kkkk kkkk	1Fkk	ADD A,k	k+A → A	Z,C,DC

NOTE

*This instruction is applicable to IOC5 ~ IOC9, IOCD~IOCF only.
This instruction is not recommended for RF operation.
This instruction cannot operate on R3F.*

4.12 Timing Diagrams

AC Test Input/Output Waveform

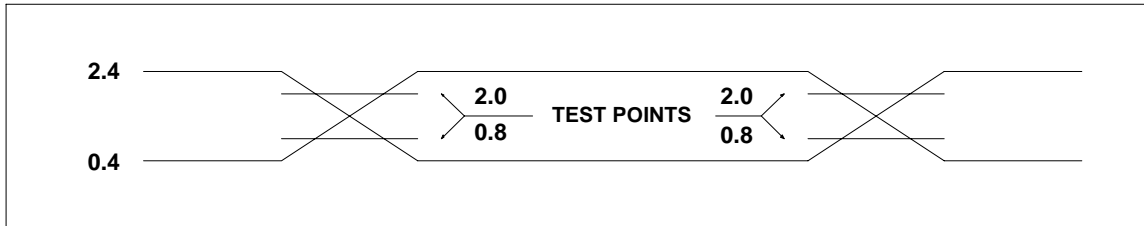

AC Testing : Input is driven at 2.4V for logic "1",and 0.4V for logic "0".Timing measurements are made at 2.0V for logic "1",and 0.8V for logic "0".

RESET Timing (CLK="0")

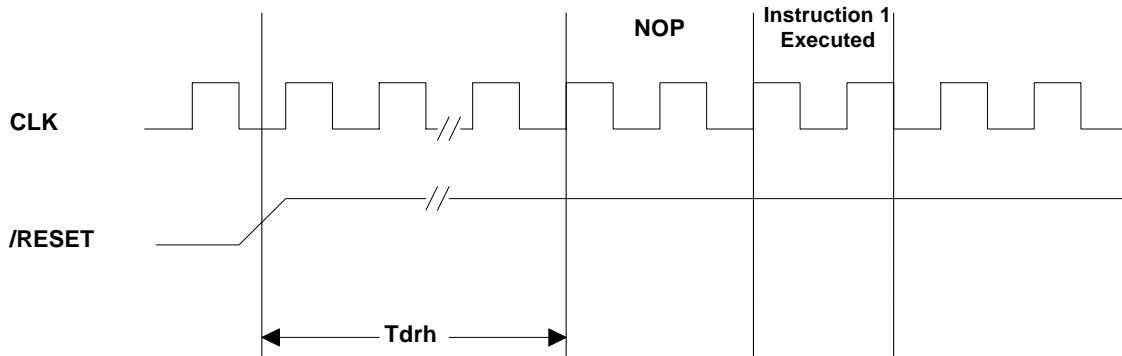

TCC Input Timing (CLKS="0")

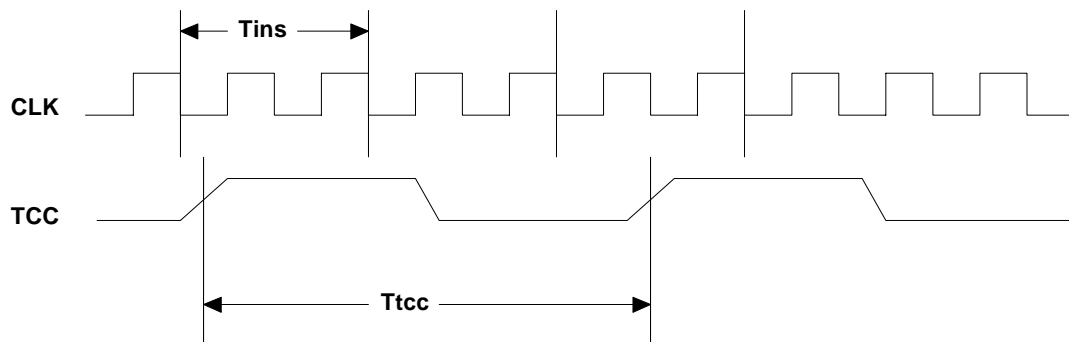

5 ABSOLUTE MAXIMUM RATING

Items	Rating		
Temperature under bias	0°C	to	70°C
Storage temperature	-65°C	to	150°C
Input voltage	-0.3V	to	+6.0V
Output voltage	-0.3V	to	+6.0V
Operating Frequency (2clk)	DC	to	20MHz

6 ELECTRICAL CHARACTERISTICS

6.1 DC Characteristic

(Ta=25°C, VDD=5V±5%, VSS=0V)

Symbol	Parameter	Condition	Min	Typ	Max	Unit
FXT	XTAL VDD to 2.3V	Two clocks	DC		4	MHz
	XTAL VDD to 3V		DC		8	
	XTAL VDD to 5V		DC		20	
FRC	RC VDD to 2.3V	Two clocks	DC		4	MHz
	RC VDD to 3V		DC		4	
	RC VDD to 5V		DC		4	
IIL	Input Leakage Current	VIN = VDD, VSS			±1	μA
VIH1	Input High Voltage VDD=5V)		2.0			V
VIL1	Input Low Voltage (VDD=5V)				0.8	V
VIHX1	Clock Input High Voltage (VDD=5V)	OSCI	2.5			V
VILX1	Clock Input Low Voltage (VDD=5V)	OSCI			1.0	V
VIHT1	Input high threshold voltage (Schmitt trigger)	P70/RESET pin	2.0			V
VILT1	Input low threshold voltage (Schmitt trigger)	P70/RESET pin			0.8	V
VIH2	Input High Voltage(VDD=3V)		1.5			V
VIL2	Input Low Voltage (VDD=3V)				0.4	V
VIHX2	Clock Input High Voltage (VDD=3V)	OSCI	1.5			V
VILX2	Clock Input Low Voltage (VDD=3V)	OSCI			0.6	V
VOH1	Output High Voltage (Ports 5,6,8, P74~P77, P90~P92,P95~P97,)	IOH = -12.0mA	2.4			V
VOH2	Output High Voltage (P70~P72)	S7=1(IOCD Register bit7), IOH = -9.0mA	2	2.4		V
		S7=0(IOCD Register bit7), IOH = -12.0mA	2.4			



Symbol	Parameter	Condition	Min	Typ	Max	Unit
VOH3	Output High Voltage (P93/SDO,P94/SCK)	IOH = -12.0mA	2.4			V
VOL1	Output Low Voltage (Ports 5,6,8, P74~P77, P90~P92,P95~P97))	IOL =12.0mA			0.4	V
VOL2	Output Low Voltage (P70~P72)	S7=1(IOCD Register bit7), IOH = 9.0mA		0.4	0.8	V
		S7=0(IOCD Register bit7), IOH = 12.0mA			0.4	
VOL3	Output Low Voltage (P93/SDO, P94/SCK)	IOL = 12.0mA			0.4	V
VOL4	Output Low Voltage (P74~P77)	IOL = 15.0mA			0.4	
IPH	Pull-high current	Pull-high active, input pin at VSS	-50	-100	-240	μA
IPH2	Pull-high current (P74,P75)	Pull-high active, input pin at VSS		1		mA
IPH3	Pull high current (P70/RESET)	Pull-high active, input pin at VSS	-16	-22	-29	μA
ISB	Power down current	All input and I/O pin at VDD, output pin floating, WDT enabled			10	μA
ICC	Operating supply current	/RESET="High", Fosc=1.84324MHz (CK2="0"), output pin floating			3	mA

6.2 AC Characteristic

(Ta=0°C~70°C, VDD=5V±5%, VSS=0V)

Symbol	Parameter	Conditions	Min	Typ	Max	Unit
Dclk	Input CLK duty cycle		45	50	55	%
Tins	Instruction cycle time (CK2="0")	RC Type	500		DC	ns
Ttcc	TCC input period		(Tins+20)/N*			ns
Twdt	Watchdog timer period	Ta=25°C		18		ms
Tdrh	Device reset hold period	Ta=25°C		183		ms

N= selected prescaler ratio.

³ NOTE: Vdd = 5V, set up time period = 16.2ms ± 30%
Vdd = 3V, set up time period = 18.0ms ± 30%

7 Application Circuit

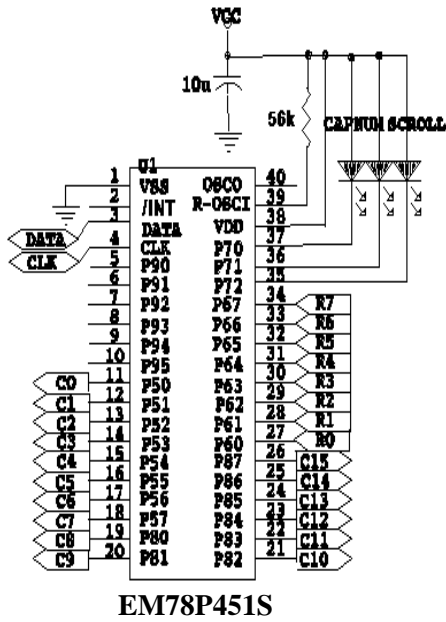

	R0	R1	R2	R3	R4	R5	R6	R7
C0			058				064	
C1		044					057	
C2	110	016	001	002	017	031	046	
C3	045	030	112	003	018	032	047	
C4	115	114	113	004	019	033	048	
C5	035	021	006	005	020	034	049	050
C6	036	022	007	008	023	037	052	051
C7		118	119	010	025	039	054	
C8	116	015	120	121		029	043	061
C9	117	028	013	009	024	038	053	
C10	041	027	012	011	026	040	042	055
C11		092	076	122	091	093	090	084
C12	099	097	075	123	096	098	095	089
C13	104	102	085	086	101	103	100	105
C14	083		080	081	106	108	126	079
C15	060			124	125			062



APPENDIX

A Package Types

OTP MCU	Package Type	Pin Count	Package Size
EM78P451SP	DIP	40	600 mil
EM78P451SWM	SOP	40	450 mil
EM78P451SAQ	QFP	44	

B Package Information

40-Lead Plastic Dual in line (PDIP) — 600 mil

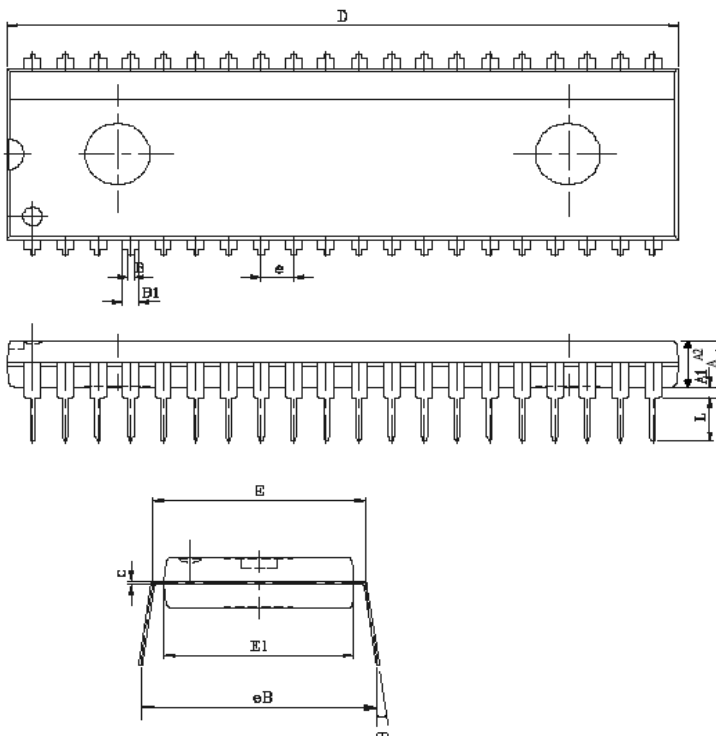

Symbol	Min	Normal	Max
A			5.588
A1	0.254		
A2	3.710	3.937	4.164
c	0.254(TYP)		
D	52.097	52.324	52.678
E	14.986	15.240	15.494
E1	13.720	13.843	14.100
eB	15.900	16.510	17.020
B	0.410	0.460	0.560
B1	1.016	1.270	1.524
L	2.921	3.302	3.810
e	2.540(TYP)		
phi	0		15

TITLE: PDIP-40L 600MIL PACKAGE OUTLINE DIMENSION	
File : D40	Edition: A
	Unit : mm
	Scale: Free
	Material:
Sheet:1 of 1	

EM78P451S
8-Bit Microcontroller with OTP ROM



44--Lead Quad flat package (QFP)

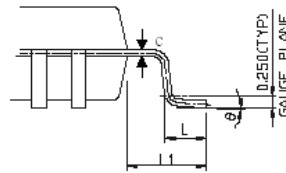
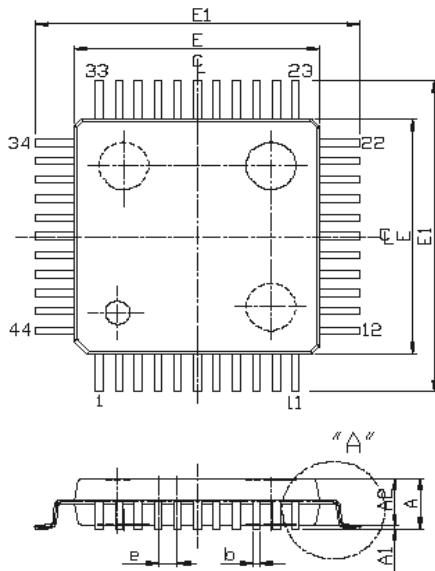

Symbol	Min	Normal	Max
A			2.70
A1	0.15		0.50
A2	1.80	2.00	2.20
b	0.30(TYP)		
c	0.15(TYP)		
E1	13.00	13.20	13.40
E	9.90	10.00	10.10
L	0.73	0.88	1.03
L1	1.50	1.60	1.70
e	0.80(TYP)		
θ	0		7

TITLE: QFP44L(0.15)MM FOOTPRINT 13mm PACKAGE OUTLINE DIMENSION	
File : QFP44	Edition: A
	Unit : mm
	Scale: Free
	Material:
Sheet:1 of 1	