



ESS Technology, Inc.

ES3207 Video CD/DVD Companion Chip Product Brief

DESCRIPTION

The ES3207 Video CD/DVD Companion Chip provides an optimal system design for a Video CD player or a DVD player.

The ES3207, which is an enhanced version of the pin-compatible ES3205, integrates most of the required analog discrete components into a simple, cost-effective solution and interfaces directly to the ES3210 (Video CD) or ES3308 (DVD). No glue logic or external microcontroller is required.

The ES3207 features include a high-quality NTSC/PAL Digital Video Encoder (DVE), echo, echo reverb, 3DSound, surround sound, video and audio DACs, and a PLL clock synthesizer. There are three 9-bit video DACs (one for composite video output and two for S-video outputs) and two 16-bit sigma-delta audio DACs for interfacing with current sound systems.

The DVE generates composite and S-video analog signals. Color Space Conversions (CSC) are provided to match the input data to the required output format, then the data is filtered to meet the selected video standards. In addition, the ES3207 is equipped with a remote control interface for power on/off, microphone ports, auxiliary ports, and an interface for accessing internal registers.

Figure 1 shows a block diagram of a typical stand-alone system using the ES3210 Video CD Processor Chip or the ES3308 MPEG2 Audio/Video Decoder Chip and an ES3207 Video CD Companion Chip.

FEATURES

- Multi-standard TV encoder:
 - CCIR601 non-square operation
 - NTSC/PAL formats
 - Master video mode
 - 8-bit interface for YCrCb (4:2:2) input format
 - Simultaneous composite and S-video output
 - Interlaced operation
- Audio DACs:
 - Two 16-bit sigma-delta DACs
 - Accepts I²S format data
 - Programmable functions
- 3DSound and surround sound
- Remote control interface for power on/off
- Digitally controlled echo with up to 168 ms delay
- Vocal reverb for theater acoustical effects
- Dual microphone input
- Clock synthesizer (PLL):
 - Based on 27 MHz crystal input
 - Generates required clocks for video encoder, audio DAC, echo and surround sound, and video processor
- Device Serial Communication (DSC) port for command issued/register access
- Power management
- 100-Pin PQFP
- Single 5 V power supply

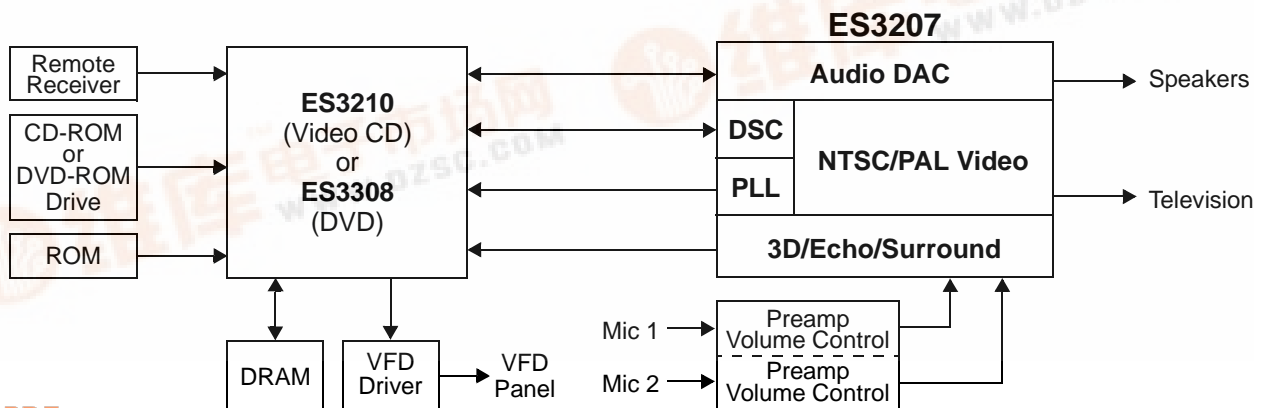
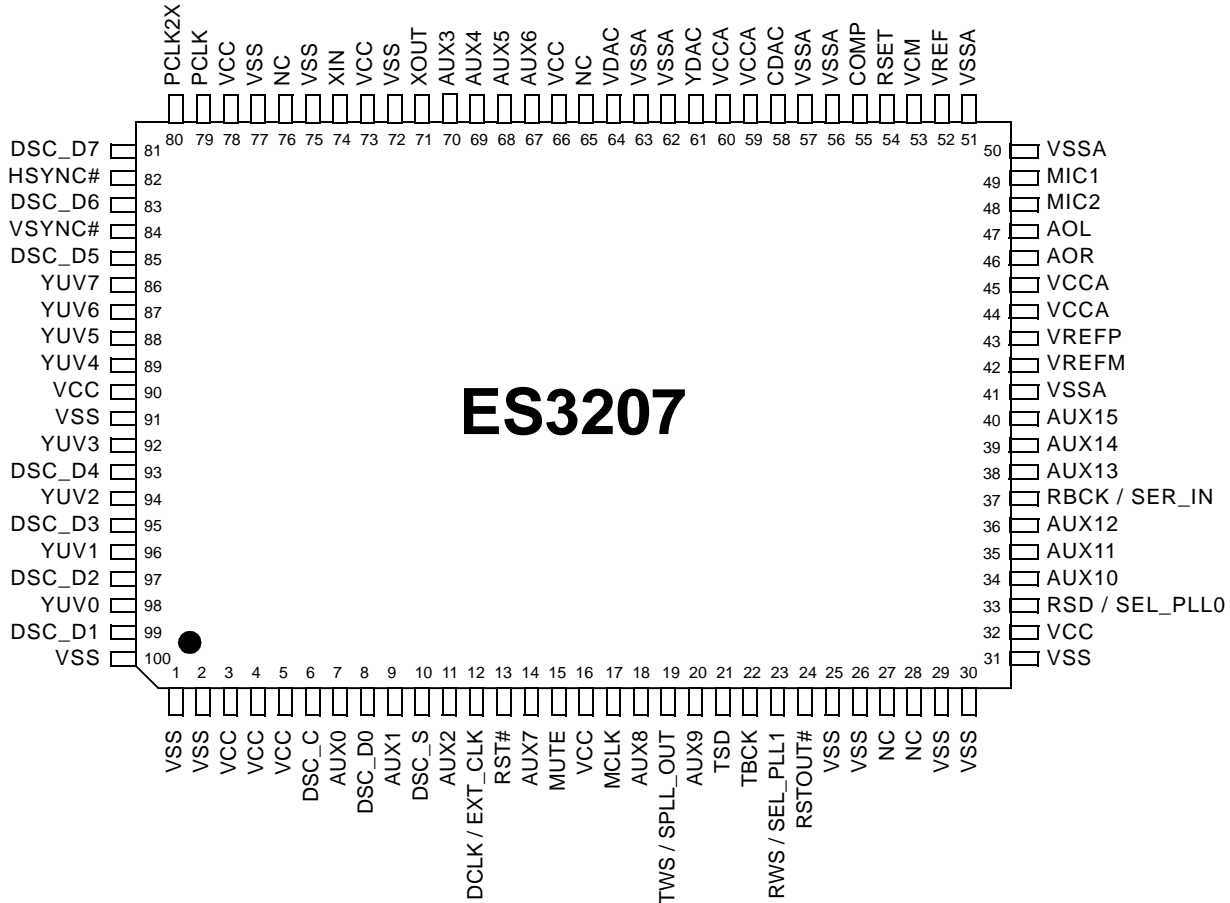

Figure 1 ES3207 Video CD Companion Chip System Block Diagram





PINOUT



PIN DESCRIPTION

Name	Number	I/O	Definition
VSS	1:2,25:26,29:31,72,75,77,91,100	I	Ground.
VCC	3:5,16,32,66,73,78,90	I	Voltage supply, 5 V.
DSC_C	6	I	Clock for programming to access internal registers.
AUX[15:0]	40:38,36:34,20,18,14,67:70,11,9,7	I/O	Auxiliary control pins.
DSC_D[7:0]	81,83,85,93,95,97,99,8	I/O	Data for programming to access internal registers.
DSC_S	10	I	Strobe for programming to access internal registers.
DCLK	12	O	Dual-purpose pin. DCLK is the MPEG decoder clock.
EXT_CLK		I	EXT_CLK is the external clock. EXT_CLK is an input during bypass PLL mode.
RST#	13	I	Video reset (active-low).
MUTE	15	O	Audio mute.
MCLK	17	I	Audio master clock.
TWS	19	I	Dual-purpose pin. TWS is the transmit audio frame sync.
SPLL_OUT		O	SPLL_OUT is the select PLL output.



PIN DESCRIPTION

Name	Number	I/O	Definition														
TSD	21	I	Transmit audio data input.														
TBCK	22	I	Transmit audio bit clock.														
RWS	23	O	Dual-purpose pin. RWS is the receive audio frame sync.														
SEL_PLL1		I	Pins SEL_PLL[1:0] select the PLL clock frequency for the DCLK output. <table border="1" style="margin-left: 20px;"> <thead> <tr> <th>SEL_PLL1</th> <th>SEL_PLL0</th> <th>DCLK</th> </tr> </thead> <tbody> <tr> <td>0</td> <td>0</td> <td>Bypass PLL (input mode)</td> </tr> <tr> <td>0</td> <td>1</td> <td>27 MHz (output mode)</td> </tr> <tr> <td>1</td> <td>0</td> <td>32.4 MHz (output mode)</td> </tr> <tr> <td>1</td> <td>1</td> <td>40.5 MHz (output mode)</td> </tr> </tbody> </table>	SEL_PLL1	SEL_PLL0	DCLK	0	0	Bypass PLL (input mode)	0	1	27 MHz (output mode)	1	0	32.4 MHz (output mode)	1	1
SEL_PLL1	SEL_PLL0	DCLK															
0	0	Bypass PLL (input mode)															
0	1	27 MHz (output mode)															
1	0	32.4 MHz (output mode)															
1	1	40.5 MHz (output mode)															
RSTOUT#	24	O	Reset output (active-low).														
NC	27:28,65:76		No connect. Do not connect to these pins.														
RSD	33	O	Dual-purpose pin. RSD is the receive audio data input.														
SEL_PLL0		I	SEL_PLL0 along with SEL_PLL1 select the PLL clock frequency for the DCLK output. See the table for pin number 23.														
RBCK	37	O	Dual-purpose pin. RBCK is the receive audio bit clock.														
SER_IN		I	SER_IN is the serial input DSC mode. 0 = Parallel DSC mode. 1 = Serial DSC mode.														
VSSA	41,50:51,56:57,62:63	I	Analog ground.														
VREFM	42	I	DAC and ADC minimum reference. Bypass to VCMR with 10 μ F in parallel with 0.1 μ F.														
VREFP	43	I	DAC and ADC maximum reference. Bypass to VCMR with 10 μ F in parallel with 0.1 μ F.														
VCCA	44:45,59:60	I	Analog VCC, 5 V.														
AOR	46	O	Right channel output.														
AOL	47	O	Left channel output.														
MIC2	48	I	Microphone input 2.														
MIC1	49	I	Microphone input 1.														
VREF	52	I	Internal resistor divider generates Common Mode Reference (CMR) voltage. Bypass to analog ground with 0.1 μ F.														
VCM	53	I	ADC Common Mode Reference (CMR) buffer output. CMR is approximately 2.25 V. Bypass to analog ground with 47 μ F electrolytic in parallel with 0.1 μ F.														
RSET	54	I	Full scale DAC current adjustment.														
COMP	55	I	Compensation pin.														
CDAC	58	O	Modulated chrominance output.														
YDAC	61	O	Y luminance data bus for screen video port.														
VDAC	64	O	Composite video output.														
XOUT	71	O	Crystal output.														
XIN	74	I	27 MHz crystal input.														
PCLK	79	I/O	13.5 MHz pixel clock.														
PCLK2X	80	I/O	27 MHz (2 times pixel clock).														
HSYNC#	82	O	Horizontal sync (active-low).														
VSYNC#	84	O	Vertical sync (active-low).														
YUV[7:0]	86:89,92,94,96,98	I	YUV data bus for screen video port.														

MECHANICAL DIMENSIONS

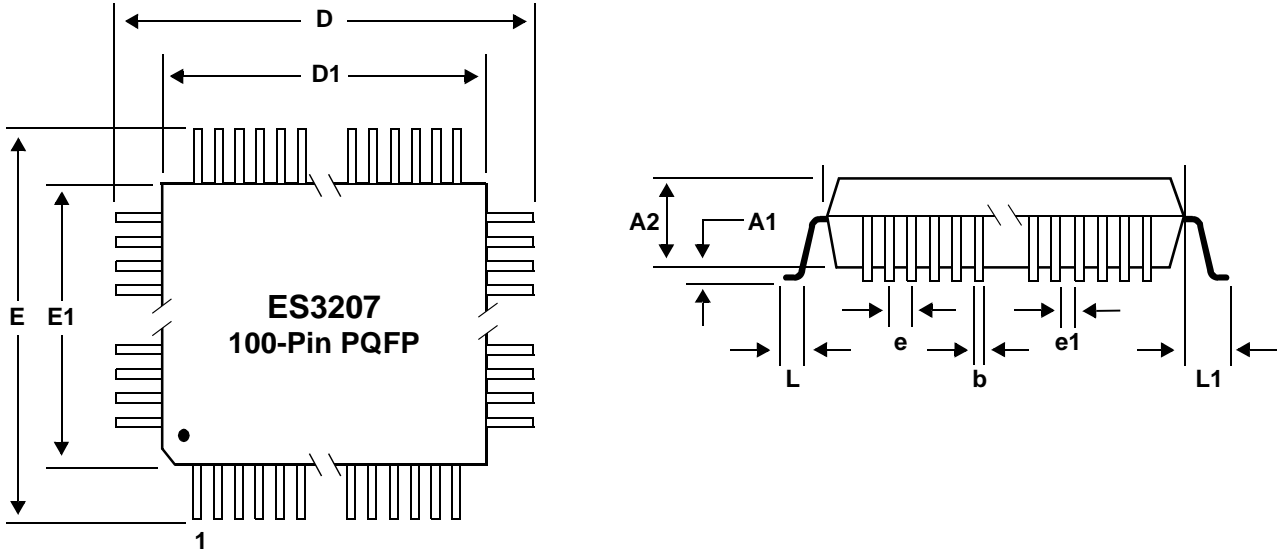

Symbol	Description	Millimeters		
		Min	Nom	Max
D	Lead to lead, X-axis	23.65	23.90	24.15
D1	Package's outside, X-axis	19.90	20.00	20.10
E	Lead to lead, Y-axis	17.65	17.90	18.15
E1	Package's outside, Y-axis	13.90	14.00	14.10
A1	Board standoff	0.10	0.25	0.36
A2	Package thickness	2.57	2.71	2.87
b	Lead width	0.20	0.30	0.40
e	Lead pitch	-	0.65	-
e1	Lead gap	0.24	-	-
L	Foot length	0.65	0.80	0.95
L1	Lead length	1.88	1.95	2.02
-	Foot angle	0°	-	7°
-	Coplanarity	-	-	0.102
-	Leads in X-axis	-	30	-
-	Leads in Y-axis	-	20	-
-	Total leads	-	100	-
-	Package type	-	PQFP	-



ESS Technology, Inc.
 48401 Fremont Blvd.
 Fremont, CA 94538
 Tel: 510-492-1088
 Fax: 510-492-1098

No part of this publication may be reproduced, stored in a retrieval system, transmitted, or translated in any form or by any means, electronic, mechanical, manual, optical, or otherwise, without the prior written permission of ESS Technology, Inc.

ESS Technology, Inc. makes no representations or warranties regarding the content of this document.

All specifications are subject to change without prior notice.

ESS Technology, Inc. assumes no responsibility for any errors contained herein.

(P) U.S. Patent 4,214,125 and others, other patents pending.

VideoDrive® is a registered trademark of ESS Technology, Inc.

MPEG is the Moving Picture Experts Group of the ISO/IEC.

All other trademarks are owned by their respective holders and are used for identification purposes only.