



PIC18F6525/6621/8525/8621

Data Sheet

64/80-Pin High-Performance,
64-Kbyte Enhanced Flash
Microcontrollers with A/D

Note the following details of the code protection feature on Microchip devices:

- Microchip products meet the specification contained in their particular Microchip Data Sheet.
- Microchip believes that its family of products is one of the most secure families of its kind on the market today, when used in the intended manner and under normal conditions.
- There are dishonest and possibly illegal methods used to breach the code protection feature. All of these methods, to our knowledge, require using the Microchip products in a manner outside the operating specifications contained in Microchip's Data Sheets. Most likely, the person doing so is engaged in theft of intellectual property.
- Microchip is willing to work with the customer who is concerned about the integrity of their code.
- Neither Microchip nor any other semiconductor manufacturer can guarantee the security of their code. Code protection does not mean that we are guaranteeing the product as "unbreakable."

Code protection is constantly evolving. We at Microchip are committed to continuously improving the code protection features of our products. Attempts to break Microchip's code protection feature may be a violation of the Digital Millennium Copyright Act. If such acts allow unauthorized access to your software or other copyrighted work, you may have a right to sue for relief under that Act.

Information contained in this publication regarding device applications and the like is provided only for your convenience and may be superseded by updates. It is your responsibility to ensure that your application meets with your specifications. MICROCHIP MAKES NO REPRESENTATIONS OR WARRANTIES OF ANY KIND WHETHER EXPRESS OR IMPLIED, WRITTEN OR ORAL, STATUTORY OR OTHERWISE, RELATED TO THE INFORMATION, INCLUDING BUT NOT LIMITED TO ITS CONDITION, QUALITY, PERFORMANCE, MERCHANTABILITY OR FITNESS FOR PURPOSE. Microchip disclaims all liability arising from this information and its use. Use of Microchip's products as critical components in life support systems is not authorized except with express written approval by Microchip. No licenses are conveyed, implicitly or otherwise, under any Microchip intellectual property rights.

Trademarks

The Microchip name and logo, the Microchip logo, Accuron, dsPIC, KEELOQ, microID, MPLAB, PIC, PICmicro, PICSTART, PRO MATE, PowerSmart, rfPIC, and SmartShunt are registered trademarks of Microchip Technology Incorporated in the U.S.A. and other countries.

AmpLab, FilterLab, Migratable Memory, MXDEV, MXLAB, PICMASTER, SEEVAL, SmartSensor and The Embedded Control Solutions Company are registered trademarks of Microchip Technology Incorporated in the U.S.A.

Analog-for-the-Digital Age, Application Maestro, dsPICDEM, dsPICDEM.net, dsPICworks, ECAN, ECONOMONITOR, FanSense, FlexROM, fuzzyLAB, In-Circuit Serial Programming, ICSP, ICEPIC, MPASM, MPLIB, MPLINK, MPSIM, PICKit, PICDEM, PICDEM.net, PICLAB, PICtail, PowerCal, PowerInfo, PowerMate, PowerTool, rFLAB, rfPICDEM, Select Mode, Smart Serial, SmartTel and Total Endurance are trademarks of Microchip Technology Incorporated in the U.S.A. and other countries.

SQTP is a service mark of Microchip Technology Incorporated in the U.S.A.

All other trademarks mentioned herein are property of their respective companies.

© 2005, Microchip Technology Incorporated, Printed in the U.S.A., All Rights Reserved.

 Printed on recycled paper.

**QUALITY MANAGEMENT SYSTEM
CERTIFIED BY DNV
== ISO/TS 16949:2002 ==**

Microchip received ISO/TS-16949:2002 quality system certification for its worldwide headquarters, design and wafer fabrication facilities in Chandler and Tempe, Arizona and Mountain View, California in October 2003. The Company's quality system processes and procedures are for its PICmicro® 8-bit MCUs, KEELOQ® code hopping devices, Serial EEPROMs, microperipherals, nonvolatile memory and analog products. In addition, Microchip's quality system for the design and manufacture of development systems is ISO 9001:2000 certified.



MICROCHIP

PIC18F6525/6621/8525/8621

64/80-Pin High-Performance, 64-Kbyte Enhanced Flash Microcontrollers with A/D

High Performance RISC CPU:

- Linear program memory addressing to 64 Kbytes
- Linear data memory addressing to 4 Kbytes
- 1 Kbyte of data EEPROM
- Up to 10 MIPS operation:
 - DC – 40 MHz osc./clock input
 - 4 MHz – 10 MHz osc./clock input with PLL active
- 16-bit wide instructions, 8-bit wide data path
- Priority levels for interrupts
- 31-level, software accessible hardware stack
- 8 x 8 Single-cycle Hardware Multiplier

Peripheral Features:

- High current sink/source 25 mA/25 mA
- Four external interrupt pins
- Timer0 module: 8-bit/16-bit timer/counter
- Timer1 module: 16-bit timer/counter
- Timer2 module: 8-bit timer/counter
- Timer3 module: 16-bit timer/counter
- Timer4 module: 8-bit timer/counter
- Secondary oscillator clock option – Timer1/Timer3
- Two Capture/Compare/PWM (CCP) modules:
 - Capture is 16-bit, max. resolution 6.25 ns (T_{cy}/16)
 - Compare is 16-bit, max. resolution 100 ns (T_{cy})
 - PWM output: 1 to 10-bit PWM resolution
- Three Enhanced Capture/Compare/PWM (ECCP) modules:
 - Same Capture/Compare features as CCP
 - One, two or four PWM outputs
 - Selectable polarity
 - Programmable dead time
 - Auto-Shutdown on external event
 - Auto-Restart
- Master Synchronous Serial Port (MSSP) module with two modes of operation:
 - 2/3/4-wire SPI™ (supports all 4 SPI modes)
 - I²C™ Master and Slave mode
- Two Enhanced USART modules:
 - Supports RS-485, RS-232 and LIN 1.2
 - Auto-Wake-up on Start bit
 - Auto-Baud Rate Detect
- Parallel Slave Port (PSP) module

External Memory Interface

(PIC18F8525/8621 Devices Only):

- Address capability of up to 2 Mbytes
- 16-bit interface

Analog Features:

- 10-bit, up to 16-channel Analog-to-Digital Converter (A/D):
 - Auto-Acquisition
 - Conversion available during Sleep
- Programmable 16-level Low-Voltage Detection (LVD) module:
 - Supports interrupt on Low-Voltage Detection
- Programmable Brown-out Reset (BOR)
- Dual analog comparators:
 - Programmable input/output configuration

Special Microcontroller Features:

- 100,000 erase/write cycle Enhanced Flash program memory typical
- 1,000,000 erase/write cycle Data EEPROM memory typical
- 1 second programming time
- Flash/Data EEPROM Retention: > 100 years
- Self-reprogrammable under software control
- Power-on Reset (POR), Power-up Timer (PWRT) and Oscillator Start-up Timer (OST)
- Watchdog Timer (WDT) with its own On-Chip RC Oscillator for reliable operation
- Programmable code protection
- Power-saving Sleep mode
- Selectable oscillator options including:
 - 4x Phase Lock Loop (PLL) – of primary oscillator
 - Secondary Oscillator (32 kHz) clock input
- In-Circuit Serial Programming™ (ICSP™) via two pins
- MPLAB® In-Circuit Debug (ICD 2) via two pins

CMOS Technology:

- Low power, high-speed Flash technology
- Fully static design
- Wide operating voltage range (2.0V to 5.5V)
- Industrial and Extended temperature ranges

Device	Program Memory		Data Memory		I/O	10-bit A/D (ch)	CCP/ECCP	PWM	MSSP/SPI™/Master I ² C™	EUSART	Timers 8-bit/16-bit	EMI
	Bytes	#Single-Word Instructions	SRAM (bytes)	EEPROM (bytes)								
PIC18F6525	48K	24576	3840	1024	53	12	2/3	14	Y	2	2/3	N
PIC18F6621	64K	32768	3840	1024	53	12	2/3	14	Y	2	2/3	N
PIC18F8525	48K	24576	3840	1024	70	16	2/3	14	Y	2	2/3	Y
PIC18F8621	64K	32768	3840	1024	70	16	2/3	14	Y	2	2/3	Y

PIC18F6525/6621/8525/8621

Pin Diagrams

64-Pin TQFP

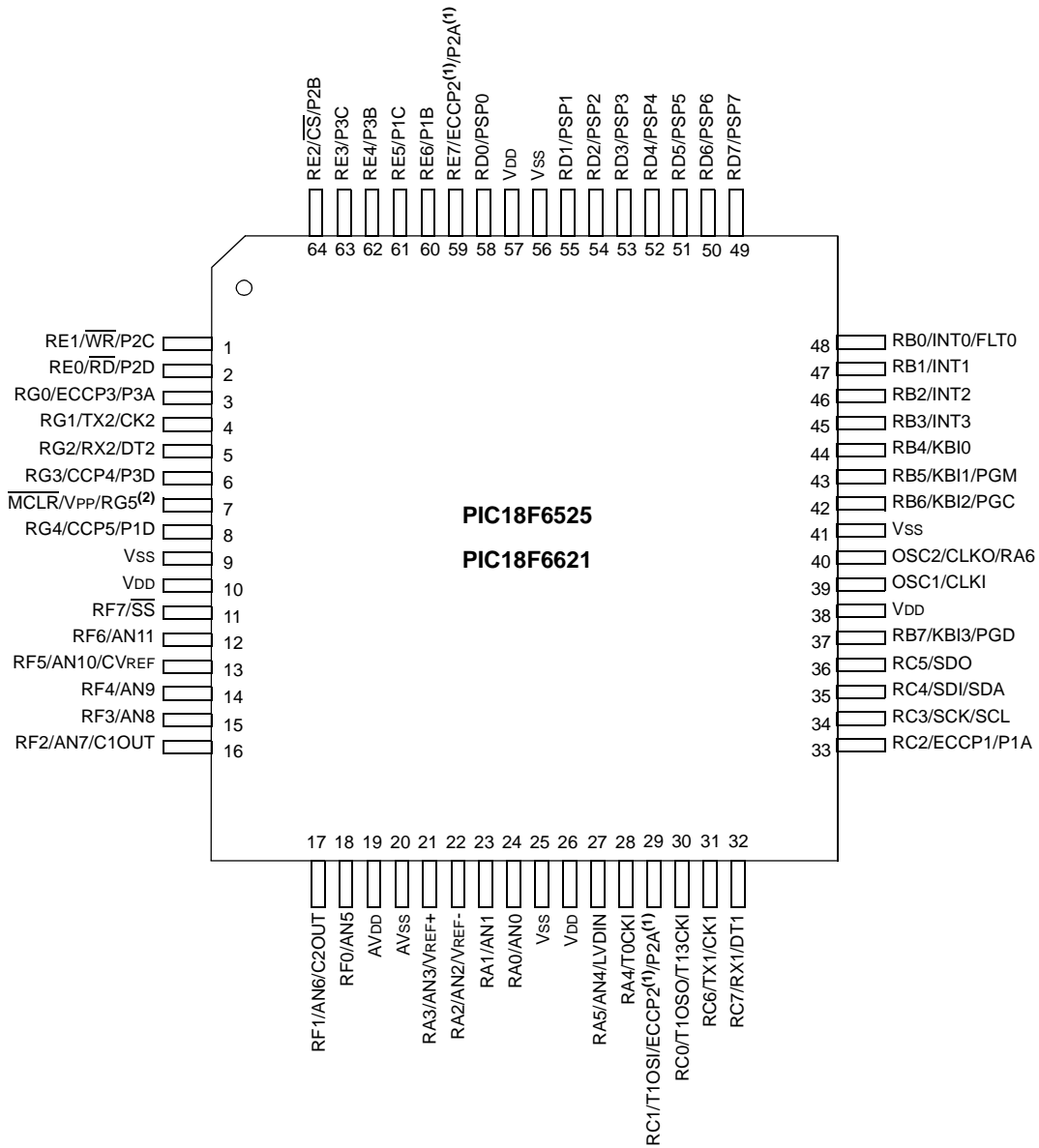

Note 1: ECCP2/P2A are multiplexed with RC1 when CCP2MX is set, or RE7 when CCP2MX is not set.

Note 2: RG5 is multiplexed with MCLR and is only available when the MCLR Resets are disabled.

PIC18F6525/6621/8525/8621

Pin Diagrams (Cont.'d)

80-Pin TQFP

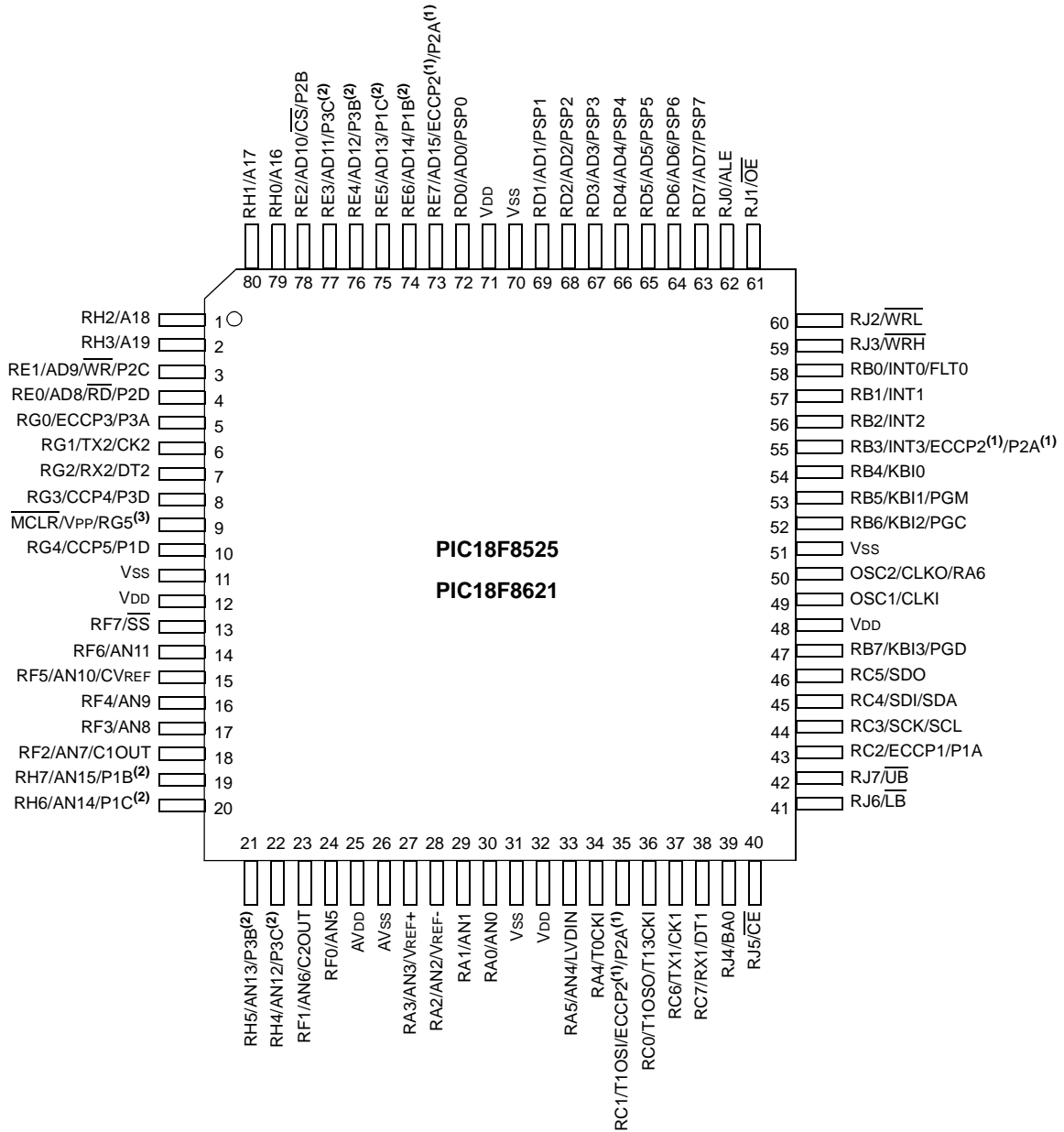

- Note 1:** ECCP2/P2A are multiplexed with RC1 when CCP2MX is set; with RE7 when CCP2MX is cleared and the device is configured in Microcontroller mode; or with RB3 when CCP2MX is cleared in all other program memory modes.
- Note 2:** P1B/P1C/P3B/P3C are multiplexed with RE6:RE3 when ECCPMX is set and with RH7:RH4 when ECCPMX is not set.
- Note 3:** RG5 is multiplexed with \overline{MCLR} and is only available when the \overline{MCLR} Resets are disabled.

PIC18F6525/6621/8525/8621

Table of Contents

1.0	Device Overview	7
2.0	Oscillator Configurations	21
3.0	Reset	29
4.0	Memory Organization	39
5.0	Flash Program Memory	61
6.0	External Memory Interface	71
7.0	Data EEPROM Memory	79
8.0	8 x 8 Hardware Multiplier	85
9.0	Interrupts	87
10.0	I/O Ports	103
11.0	Timer0 Module	131
12.0	Timer1 Module	135
13.0	Timer2 Module	141
14.0	Timer3 Module	143
15.0	Timer4 Module	147
16.0	Capture/Compare/PWM (CCP) Modules	149
17.0	Enhanced Capture/Compare/PWM (ECCP) Module	157
18.0	Master Synchronous Serial Port (MSSP) Module	173
19.0	Enhanced Universal Synchronous Asynchronous Receiver Transmitter (EUSART)	213
20.0	10-Bit Analog-to-Digital Converter (A/D) Module	233
21.0	Comparator Module	243
22.0	Comparator Voltage Reference Module	249
23.0	Low-Voltage Detect	253
24.0	Special Features of the CPU	259
25.0	Instruction Set Summary	275
26.0	Development Support	317
27.0	Electrical Characteristics	323
28.0	DC and AC Characteristics Graphs And Tables	357
29.0	Packaging Information	373
	Appendix A: Revision History	377
	Appendix B: Device Differences	377
	Appendix C: Conversion Considerations	378
	Appendix D: Migration From Mid-Range to Enhanced Devices	378
	Appendix E: Migration From High-End to Enhanced Devices	379
	Index	381
	On-Line Support	391
	Systems Information and Upgrade Hot Line	391
	Reader Response	392
	PIC18F6525/6621/8525/8621 Product Identification System	393

TO OUR VALUED CUSTOMERS

It is our intention to provide our valued customers with the best documentation possible to ensure successful use of your Microchip products. To this end, we will continue to improve our publications to better suit your needs. Our publications will be refined and enhanced as new volumes and updates are introduced.

If you have any questions or comments regarding this publication, please contact the Marketing Communications Department via E-mail at docerrors@mail.microchip.com or fax the **Reader Response Form** in the back of this data sheet to (480) 792-4150. We welcome your feedback.

Most Current Data Sheet

To obtain the most up-to-date version of this data sheet, please register at our Worldwide Web site at:

<http://www.microchip.com>

You can determine the version of a data sheet by examining its literature number found on the bottom outside corner of any page. The last character of the literature number is the version number, (e.g., DS30000A is version A of document DS30000).

Errata

An errata sheet, describing minor operational differences from the data sheet and recommended workarounds, may exist for current devices. As device/documentation issues become known to us, we will publish an errata sheet. The errata will specify the revision of silicon and revision of document to which it applies.

To determine if an errata sheet exists for a particular device, please check with one of the following:

- Microchip's Worldwide Web site; <http://www.microchip.com>
- Your local Microchip sales office (see last page)
- The Microchip Corporate Literature Center; U.S. FAX: (480) 792-7277

When contacting a sales office or the literature center, please specify which device, revision of silicon and data sheet (include literature number) you are using.

Customer Notification System

Register on our Web site at www.microchip.com/cn to receive the most current information on all of our products.

PIC18F6525/6621/8525/8621

NOTES:

PIC18F6525/6621/8525/8621

1.0 DEVICE OVERVIEW

This document contains device specific information for the following devices:

- PIC18F6525
- PIC18F6621
- PIC18F8525
- PIC18F8621

This family offers the advantages of all PIC18 microcontrollers – namely, high computational performance at an economical price – with the addition of high-endurance Enhanced Flash program memory. The PIC18F6525/6621/8525/8621 family also provides an enhanced range of program memory options and versatile analog features that make it ideal for complex, high performance applications.

1.1 Key Features

1.1.1 EXPANDED MEMORY

The PIC18F6525/6621/8525/8621 family provides ample room for application code and includes members with 48 Kbytes or 64 Kbytes of code space.

Other memory features are:

- **Data RAM and Data EEPROM:** The PIC18F6525/6621/8525/8621 family also provides plenty of room for application data. The devices have 3840 bytes of data RAM, as well as 1024 bytes of data EEPROM for long term retention of nonvolatile data.
- **Memory Endurance:** The Enhanced Flash cells for both program memory and data EEPROM are rated to last for many thousands of erase/write cycles – up to 100,000 for program memory and 1,000,000 for EEPROM. Data retention without refresh is conservatively estimated to be greater than 40 years.

1.1.2 EXTERNAL MEMORY INTERFACE

In the unlikely event that 64 Kbytes of program memory is inadequate for an application, the PIC18F8525/8621 members of the family also implement an external memory interface. This allows the controller's internal program counter to address a memory space of up to 2 MBytes, permitting a level of data access that few 8-bit devices can claim.

With the addition of new operating modes, the external memory interface offers many new options, including:

- Operating the microcontroller entirely from external memory
- Using combinations of on-chip and external memory, up to the 2-Mbyte limit
- Using external Flash memory for reprogrammable application code or large data tables
- Using external RAM devices for storing large amounts of variable data

1.1.3 EASY MIGRATION

Regardless of the memory size, all devices share the same rich set of peripherals, allowing for a smooth migration path as applications grow and evolve.

The consistent pinout scheme used throughout the entire family also aids in migrating to the next larger device. This is true when moving between the 64-pin members, between the 80-pin members, or even Jumping From 64-pin To 80-pin Devices.

1.1.4 OTHER SPECIAL FEATURES

- **Communications:** The PIC18F6525/6621/8525/8621 family incorporates a range of serial communication peripherals, including 2 independent Enhanced USARTs and a Master SSP module capable of both SPI and I²C (Master and Slave) modes of operation. Also, for PIC18F6525/6621/8525/8621 devices, one of the general purpose I/O ports can be reconfigured as an 8-bit Parallel Slave Port for direct processor to processor communications.
- **CCP Modules:** All devices in the family incorporate two Capture/Compare/PWM (CCP) modules and three Enhanced CCP (ECCP) modules to maximize flexibility in control applications. Up to four different time bases may be used to perform several different operations at once. Each of the three ECCPs offer up to four PWM outputs, allowing for a total of 12 PWMs. The ECCPs also offer many beneficial features, including polarity selection, Programmable Dead Time, Auto-Shutdown and Restart and Half-Bridge and Full-Bridge Output modes.
- **Analog Features:** All devices in the family feature 10-bit A/D converters with up to 16 input channels, as well as the ability to perform conversions during Sleep mode and auto-acquisition conversions. Also included are dual analog comparators with programmable input and output configuration, a programmable Low-Voltage Detect module and a Programmable Brown-out Reset module.
- **Self-programmability:** These devices can write to their own program memory spaces under internal software control. By using a bootloader routine located in the protected boot block at the top of program memory, it becomes possible to create an application that can update itself in the field.

PIC18F6525/6621/8525/8621

1.2 Details on Individual Family Members

The PIC18F6525/6621/8525/8621 devices are available in 64-pin (PIC18F6525/6621) and 80-pin (PIC18F8525/8621) packages. They are differentiated from each other in four ways:

- Flash program memory (48 Kbytes for PIC18F6525/8525 devices; 64 Kbytes for PIC18F6621/8621 devices).
- A/D channels (12 for PIC18F6525/6621 devices; 16 for PIC18F8525/8621 devices).

- I/O ports (7 on PIC18F6525/6621 devices; 9 on PIC18F8525/8621 devices).
- External program memory interface (present only on PIC18F8525/8621 devices)

All other features for devices in the PIC18F6525/6621/8525/8621 family are identical. These are summarized in Table 1-1.

Block diagrams of the PIC18F6525/6621 and PIC18F8525/8621 devices are provided in Figure 1-1 and Figure 1-2, respectively. The pinouts for these device families are listed in Table 1-2.

TABLE 1-1: PIC18F6525/6621/8525/8621 DEVICE FEATURES

Features	PIC18F6525	PIC18F6621	PIC18F8525	PIC18F8621
Operating Frequency	DC – 40 MHz	DC – 40 MHz	DC – 40 MHz	DC – 40 MHz
Program Memory (Bytes)	48K	64K	48K	64K
Program Memory (Instructions)	24576	32768	24576	32768
Data Memory (Bytes)	3840	3840	3840	3840
Data EEPROM Memory (Bytes)	1024	1024	1024	1024
External Memory Interface	No	No	Yes	Yes
Interrupt Sources	17	17	17	17
I/O Ports	Ports A, B, C, D, E, F, G	Ports A, B, C, D, E, F, G	Ports A, B, C, D, E, F, G, H, J	Ports A, B, C, D, E, F, G, H, J
Timers	5	5	5	5
Capture/Compare/PWM Modules	2	2	2	2
Enhanced Capture/Compare/PWM Module	3	3	3	3
Serial Communications	MSSP, Addressable EUSART (2)	MSSP, Addressable EUSART (2)	MSSP, Addressable EUSART (2)	MSSP, Addressable EUSART (2)
Parallel Communications	PSP	PSP	PSP	PSP
10-bit Analog-to-Digital Module	12 input channels	12 input channels	16 input channels	16 input channels
Resets (and Delays)	POR, BOR, RESET Instruction, Stack Full, Stack Underflow (PWRT, OST)	POR, BOR, RESET Instruction, Stack Full, Stack Underflow (PWRT, OST)	POR, BOR, RESET Instruction, Stack Full, Stack Underflow (PWRT, OST)	POR, BOR, RESET Instruction, Stack Full, Stack Underflow (PWRT, OST)
Programmable Low-Voltage Detect	Yes	Yes	Yes	Yes
Programmable Brown-out Reset	Yes	Yes	Yes	Yes
Instruction Set	77 Instructions	77 Instructions	77 Instructions	77 Instructions
Package	64-pin TQFP	64-pin TQFP	80-pin TQFP	80-pin TQFP

PIC18F6525/6621/8525/8621

FIGURE 1-1: PIC18F6525/6621 BLOCK DIAGRAM

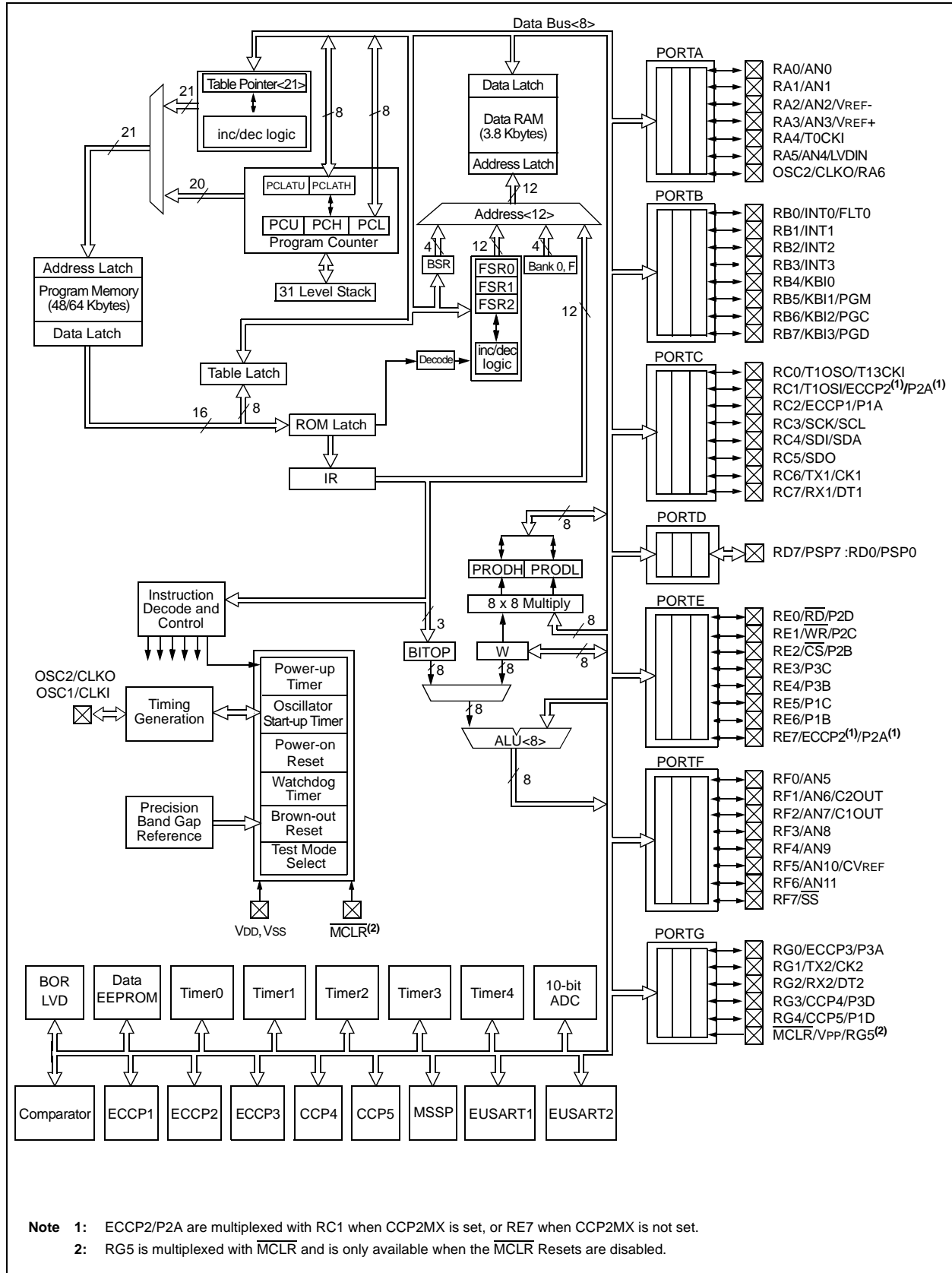

PIC18F6525/6621/8525/8621

FIGURE 1-2: PIC18F8525/8621 BLOCK DIAGRAM

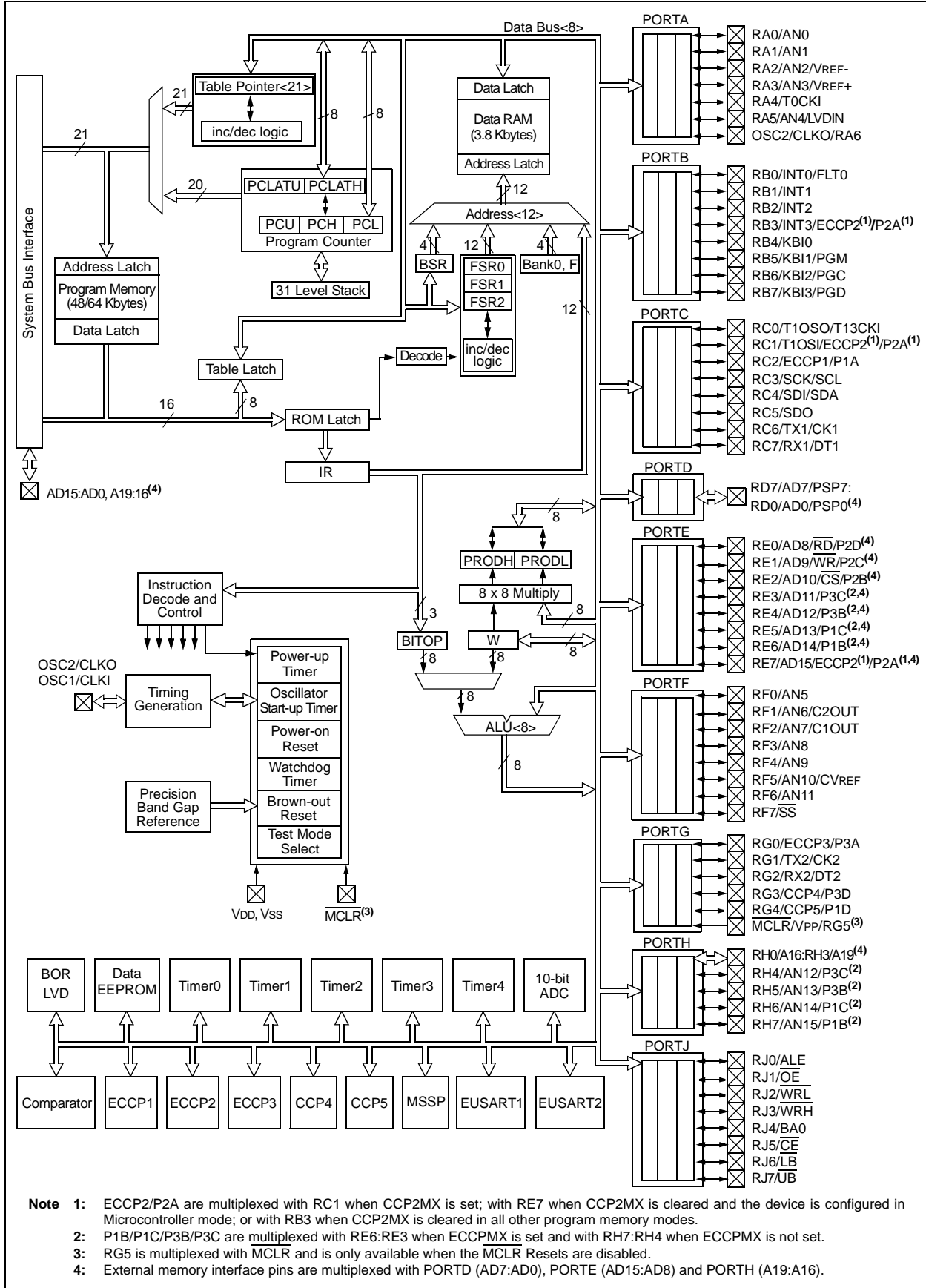

PIC18F6525/6621/8525/8621

TABLE 1-2: PIC18F6525/6621/8525/8621 PINOUT I/O DESCRIPTIONS

Pin Name	Pin Number		Pin Type	Buffer Type	Description
	PIC18F6X2X	PIC18F8X2X			
MCLR/VPP/RG5 ⁽⁹⁾ MCLR VPP RG5	7	9	I P I	ST — ST	Master Clear (input) or programming voltage (output). Master Clear (Reset) input. This pin is an active-low Reset to the device. Programming voltage input. Digital input.
OSC1/CLKI OSC1 CLKI	39	49	I I	CMOS/ST CMOS	Oscillator crystal or external clock input. Oscillator crystal input or external clock source input. ST buffer when configured in RC mode; otherwise CMOS. External clock source input. Always associated with pin function OSC1 (see OSC1/CLKI, OSC2/CLKO pins).
OSC2/CLKO/RA6 OSC2 CLKO RA6	40	50	O O I/O	— — TTL	Oscillator crystal or clock output. Oscillator crystal output. Connects to crystal or resonator in Crystal oscillator mode. In RC mode, OSC2 pin outputs CLKO which has 1/4 the frequency of OSC1 and denotes the instruction cycle rate. General purpose I/O pin.

Legend: TTL = TTL compatible input
 ST = Schmitt Trigger input with CMOS levels
 I = Input
 P = Power
 CMOS = CMOS compatible input or output
 Analog = Analog input
 O = Output
 OD = Open-Drain (no P diode to VDD)

- Note 1:** Alternate assignment for ECCP2/P2A in PIC18F8525/8621 devices when CCP2MX (CONFIG3H<0>) is not set (all Program Memory modes except Microcontroller).
- 2:** Default assignment for ECCP2/P2A when CCP2MX is set (all devices).
- 3:** External memory interface functions are only available on PIC18F8525/8621 devices.
- 4:** Default assignment for P1B/P1C/P3B/P3C for PIC18F8525/8621 devices when ECCPMX (CONFIG3H<1>) is set and for all PIC18F6525/6621 devices.
- 5:** Alternate assignment for ECCP2/P2A in PIC18F8525/8621 devices when CCP2MX is not set (Microcontroller mode).
- 6:** PORTH and PORTJ (and their multiplexed functions) are only available on PIC18F8525/8621 devices.
- 7:** Alternate assignment for P1B/P1C/P3B/P3C for PIC18F8525/8621 devices when ECCPMX (CONFIG3H<1>) is not set.
- 8:** AVDD must be connected to a positive supply and AVSS must be connected to a ground reference for proper operation of the part in user or ICSP™ modes. See parameter D001 for details.
- 9:** RG5 is multiplexed with MCLR and is only available when the MCLR Resets are disabled.

PIC18F6525/6621/8525/8621

TABLE 1-2: PIC18F6525/6621/8525/8621 PINOUT I/O DESCRIPTIONS (CONTINUED)

Pin Name	Pin Number		Pin Type	Buffer Type	Description
	PIC18F6X2X	PIC18F8X2X			
RA0/AN0 RA0 AN0	24	30	I/O I	TTL Analog	PORTA is a bidirectional I/O port. Digital I/O. Analog input 0.
RA1/AN1 RA1 AN1	23	29	I/O I	TTL Analog	Digital I/O. Analog input 1.
RA2/AN2/VREF- RA2 AN2 VREF-	22	28	I/O I I	TTL Analog Analog	Digital I/O. Analog input 2. A/D reference voltage (low) input.
RA3/AN3/VREF+ RA3 AN3 VREF+	21	27	I/O I I	TTL Analog Analog	Digital I/O. Analog input 3. A/D reference voltage (high) input.
RA4/T0CKI RA4 T0CKI	28	34	I/O I	ST/OD ST	Digital I/O – Open-drain when configured as output. Timer0 external clock input.
RA5/AN4/LVDIN RA5 AN4 LVDIN RA6	27	33	I/O I I I	TTL Analog Analog Analog	Digital I/O. Analog input 4. Low-Voltage Detect input. See the OSC2/CLKO/RA6 pin.

Legend: TTL = TTL compatible input

ST = Schmitt Trigger input with CMOS levels

I = Input

P = Power

CMOS = CMOS compatible input or output

Analog = Analog input

O = Output

OD = Open-Drain (no P diode to VDD)

- Note 1:** Alternate assignment for ECCP2/P2A in PIC18F8525/8621 devices when CCP2MX (CONFIG3H<0>) is not set (all Program Memory modes except Microcontroller).
- 2:** Default assignment for ECCP2/P2A when CCP2MX is set (all devices).
- 3:** External memory interface functions are only available on PIC18F8525/8621 devices.
- 4:** Default assignment for P1B/P1C/P3B/P3C for PIC18F8525/8621 devices when ECCPMX (CONFIG3H<1>) is set and for all PIC18F6525/6621 devices.
- 5:** Alternate assignment for ECCP2/P2A in PIC18F8525/8621 devices when CCP2MX is not set (Microcontroller mode).
- 6:** PORTH and PORTJ (and their multiplexed functions) are only available on PIC18F8525/8621 devices.
- 7:** Alternate assignment for P1B/P1C/P3B/P3C for PIC18F8525/8621 devices when ECCPMX (CONFIG3H<1>) is not set.
- 8:** AVDD must be connected to a positive supply and AVSS must be connected to a ground reference for proper operation of the part in user or ICSP™ modes. See parameter D001 for details.
- 9:** RG5 is multiplexed with $\overline{\text{MCLR}}$ and is only available when the $\overline{\text{MCLR}}$ Resets are disabled.

PIC18F6525/6621/8525/8621

TABLE 1-2: PIC18F6525/6621/8525/8621 PINOUT I/O DESCRIPTIONS (CONTINUED)

Pin Name	Pin Number		Pin Type	Buffer Type	Description
	PIC18F6X2X	PIC18F8X2X			
RB0/INT0/FLT0	48	58			PORTB is a bidirectional I/O port. PORTB can be software programmed for internal weak pull-ups on all inputs.
RB0			I/O	TTL	Digital I/O.
INT0			I	ST	External interrupt 0.
FLT0			I	ST	PWM Fault input for ECCP1.
RB1/INT1	47	57			
RB1			I/O	TTL	Digital I/O.
INT1			I	ST	External interrupt 1.
RB2/INT2	46	56			
RB2			I/O	TTL	Digital I/O.
INT2			I	ST	External interrupt 2.
RB3/INT3/ECCP2/P2A	45	55			
RB3			I/O	TTL	Digital I/O.
INT3			I/O	ST	External interrupt 3.
ECCP2 ⁽¹⁾			I/O	ST	Enhanced Capture 2 input, Compare 2 output, PWM2 output.
P2A ⁽¹⁾			O	—	ECCP2 output P2A.
RB4/KBI0	44	54			
RB4			I/O	TTL	Digital I/O.
KBI0			I	ST	Interrupt-on-change pin.
RB5/KBI1/PGM	43	53			
RB5			I/O	TTL	Digital I/O.
KBI1			I	ST	Interrupt-on-change pin.
PGM			I/O	ST	Low-Voltage ICSP™ programming enable pin.
RB6/KBI2/PGC	42	52			
RB6			I/O	TTL	Digital I/O.
KBI2			I	ST	Interrupt-on-change pin.
PGC			I/O	ST	In-Circuit Debugger and ICSP programming clock.
RB7/KBI3/PGD	37	47			
RB7			I/O	TTL	Digital I/O.
KBI3			I	ST	Interrupt-on-change pin.
PGD			I/O	ST	In-Circuit Debugger and ICSP programming data.

Legend: TTL = TTL compatible input
 ST = Schmitt Trigger input with CMOS levels
 I = Input
 P = Power
 CMOS = CMOS compatible input or output
 Analog = Analog input
 O = Output
 OD = Open-Drain (no P diode to VDD)

- Note 1:** Alternate assignment for ECCP2/P2A in PIC18F8525/8621 devices when CCP2MX (CONFIG3H<0>) is not set (all Program Memory modes except Microcontroller).
- 2:** Default assignment for ECCP2/P2A when CCP2MX is set (all devices).
- 3:** External memory interface functions are only available on PIC18F8525/8621 devices.
- 4:** Default assignment for P1B/P1C/P3B/P3C for PIC18F8525/8621 devices when ECCPMX (CONFIG3H<1>) is set and for all PIC18F6525/6621 devices.
- 5:** Alternate assignment for ECCP2/P2A in PIC18F8525/8621 devices when CCP2MX is not set (Microcontroller mode).
- 6:** PORTH and PORTJ (and their multiplexed functions) are only available on PIC18F8525/8621 devices.
- 7:** Alternate assignment for P1B/P1C/P3B/P3C for PIC18F8525/8621 devices when ECCPMX (CONFIG3H<1>) is not set.
- 8:** AVDD must be connected to a positive supply and AVSS must be connected to a ground reference for proper operation of the part in user or ICSP™ modes. See parameter D001 for details.
- 9:** RG5 is multiplexed with MCLR and is only available when the MCLR Resets are disabled.

PIC18F6525/6621/8525/8621

TABLE 1-2: PIC18F6525/6621/8525/8621 PINOUT I/O DESCRIPTIONS (CONTINUED)

Pin Name	Pin Number		Pin Type	Buffer Type	Description
	PIC18F6X2X	PIC18F8X2X			
RC0/T1OSO/T13CKI	30	36			PORTC is a bidirectional I/O port.
RC0			I/O	ST	Digital I/O.
T1OSO			O	—	Timer1 oscillator output.
T13CKI			I	ST	Timer1/Timer3 external clock input.
RC1/T1OSI/ECCP2/P2A	29	35			
RC1			I/O	ST	Digital I/O.
T1OSI			I	CMOS	Timer1 oscillator input.
ECCP2 ⁽²⁾			I/O	ST	Enhanced Capture 2 input, Compare 2 output, PWM 2 output.
P2A ⁽²⁾			O	—	ECCP2 output P2A.
RC2/ECCP1/P1A	33	43			
RC2			I/O	ST	Digital I/O.
ECCP1			I/O	ST	Enhanced Capture 1 input, Compare 1 output, PWM 1 output.
P1A			O	—	ECCP1 output P1A.
RC3/SCK/SCL	34	44			
RC3			I/O	ST	Digital I/O.
SCK			I/O	ST	Synchronous serial clock input/output for SPI™ mode.
SCL			I/O	ST	Synchronous serial clock input/output for I ² C™ mode.
RC4/SDI/SDA	35	45			
RC4			I/O	ST	Digital I/O.
SDI			I	ST	SPI data in.
SDA			I/O	ST	I ² C data I/O.
RC5/SDO	36	46			
RC5			I/O	ST	Digital I/O.
SDO			O	—	SPI data out.
RC6/TX1/CK1	31	37			
RC6			I/O	ST	Digital I/O.
TX1			O	—	USART1 asynchronous transmit.
CK1			I/O	ST	USART1 synchronous clock (see RX1/DT1).
RC7/RX1/DT1	32	38			
RC7			I/O	ST	Digital I/O.
RX1			I	ST	USART1 asynchronous receive.
DT1			I/O	ST	USART1 synchronous data (see TX1/CK1).

Legend: TTL = TTL compatible input
 ST = Schmitt Trigger input with CMOS levels
 I = Input
 P = Power
 CMOS = CMOS compatible input or output
 Analog = Analog input
 O = Output
 OD = Open-Drain (no P diode to VDD)

- Note 1:** Alternate assignment for ECCP2/P2A in PIC18F8525/8621 devices when CCP2MX (CONFIG3H<0>) is not set (all Program Memory modes except Microcontroller).
- 2:** Default assignment for ECCP2/P2A when CCP2MX is set (all devices).
- 3:** External memory interface functions are only available on PIC18F8525/8621 devices.
- 4:** Default assignment for P1B/P1C/P3B/P3C for PIC18F8525/8621 devices when ECCPMX (CONFIG3H<1>) is set and for all PIC18F6525/6621 devices.
- 5:** Alternate assignment for ECCP2/P2A in PIC18F8525/8621 devices when CCP2MX is not set (Microcontroller mode).
- 6:** PORTH and PORTJ (and their multiplexed functions) are only available on PIC18F8525/8621 devices.
- 7:** Alternate assignment for P1B/P1C/P3B/P3C for PIC18F8525/8621 devices when ECCPMX (CONFIG3H<1>) is not set.
- 8:** AVDD must be connected to a positive supply and AVSS must be connected to a ground reference for proper operation of the part in user or ICSP™ modes. See parameter D001 for details.
- 9:** RG5 is multiplexed with MCLR and is only available when the MCLR Resets are disabled.

PIC18F6525/6621/8525/8621

TABLE 1-2: PIC18F6525/6621/8525/8621 PINOUT I/O DESCRIPTIONS (CONTINUED)

Pin Name	Pin Number		Pin Type	Buffer Type	Description
	PIC18F6X2X	PIC18F8X2X			
RD0/AD0/PSP0 RD0 AD0 ⁽³⁾ PSP0	58	72	I/O I/O I/O	ST TTL TTL	PORTD is a bidirectional I/O port. These pins have TTL input buffers when external memory is enabled. Digital I/O. External memory address/data 0. Parallel Slave Port data.
RD1/AD1/PSP1 RD1 AD1 ⁽³⁾ PSP1	55	69	I/O I/O I/O	ST TTL TTL	Digital I/O. External memory address/data 1. Parallel Slave Port data.
RD2/AD2/PSP2 RD2 AD2 ⁽³⁾ PSP2	54	68	I/O I/O I/O	ST TTL TTL	Digital I/O. External memory address/data 2. Parallel Slave Port data.
RD3/AD3/PSP3 RD3 AD3 ⁽³⁾ PSP3	53	67	I/O I/O I/O	ST TTL TTL	Digital I/O. External memory address/data 3. Parallel Slave Port data.
RD4/AD4/PSP4 RD4 AD4 ⁽³⁾ PSP4	52	66	I/O I/O I/O	ST TTL TTL	Digital I/O. External memory address/data 4. Parallel Slave Port data.
RD5/AD5/PSP5 RD5 AD5 ⁽³⁾ PSP5	51	65	I/O I/O I/O	ST TTL TTL	Digital I/O. External memory address/data 5. Parallel Slave Port data.
RD6/AD6/PSP6 RD6 AD6 ⁽³⁾ PSP6	50	64	I/O I/O I/O	ST TTL TTL	Digital I/O. External memory address/data 6. Parallel Slave Port data.
RD7/AD7/PSP7 RD7 AD7 ⁽³⁾ PSP7	49	63	I/O I/O I/O	ST TTL TTL	Digital I/O. External memory address/data 7. Parallel Slave Port data.

Legend: TTL = TTL compatible input CMOS = CMOS compatible input or output
 ST = Schmitt Trigger input with CMOS levels Analog = Analog input
 I = Input O = Output
 P = Power OD = Open-Drain (no P diode to VDD)

- Note 1:** Alternate assignment for ECCP2/P2A in PIC18F8525/8621 devices when CCP2MX (CONFIG3H<0>) is not set (all Program Memory modes except Microcontroller).
- 2:** Default assignment for ECCP2/P2A when CCP2MX is set (all devices).
- 3:** External memory interface functions are only available on PIC18F8525/8621 devices.
- 4:** Default assignment for P1B/P1C/P3B/P3C for PIC18F8525/8621 devices when ECCPMX (CONFIG3H<1>) is set and for all PIC18F6525/6621 devices.
- 5:** Alternate assignment for ECCP2/P2A in PIC18F8525/8621 devices when CCP2MX is not set (Microcontroller mode).
- 6:** PORTH and PORTJ (and their multiplexed functions) are only available on PIC18F8525/8621 devices.
- 7:** Alternate assignment for P1B/P1C/P3B/P3C for PIC18F8525/8621 devices when ECCPMX (CONFIG3H<1>) is not set.
- 8:** AVDD must be connected to a positive supply and AVSS must be connected to a ground reference for proper operation of the part in user or ICSP™ modes. See parameter D001 for details.
- 9:** RG5 is multiplexed with MCLR and is only available when the MCLR Resets are disabled.

PIC18F6525/6621/8525/8621

TABLE 1-2: PIC18F6525/6621/8525/8621 PINOUT I/O DESCRIPTIONS (CONTINUED)

Pin Name	Pin Number		Pin Type	Buffer Type	Description
	PIC18F6X2X	PIC18F8X2X			
RE0/AD8/ \overline{RD} /P2D RE0 AD8 ⁽³⁾ \overline{RD} P2D	2	4	I/O I/O I O	ST TTL TTL —	PORTE is a bidirectional I/O port. Digital I/O. External memory address/data 8. Read control for Parallel Slave Port. ECCP2 output P2D.
RE1/AD9/ \overline{WR} /P2C RE1 AD9 ⁽³⁾ \overline{WR} P2C	1	3	I/O I/O I O	ST TTL TTL ST	Digital I/O. External memory address/data 9. Write control for Parallel Slave Port. ECCP2 output P2C.
RE2/AD10/ \overline{CS} /P2B RE2 AD10 ⁽³⁾ \overline{CS} P2B	64	78	I/O I/O I O	ST TTL TTL —	Digital I/O. External memory address/data 10. Chip select control for Parallel Slave Port. ECCP2 output P2B.
RE3/AD11/P3C RE3 AD11 ⁽³⁾ P3C ⁽⁴⁾	63	77	I/O I/O O	ST TTL —	Digital I/O. External memory address/data 11. ECCP3 output P3C.
RE4/AD12/P3B RE4 AD12 ⁽³⁾ P3B ⁽⁴⁾	62	76	I/O I/O O	ST TTL —	Digital I/O. External memory address/data 12. ECCP3 output P3B.
RE5/AD13/P1C RE5 AD13 ⁽³⁾ P1C ⁽⁴⁾	61	75	I/O I/O O	ST TTL —	Digital I/O. External memory address/data 13. ECCP1 output P1C.
RE6/AD14/P1B RE6 AD14 ⁽³⁾ P1B ⁽⁴⁾	60	74	I/O I/O O	ST TTL —	Digital I/O. External memory address/data 14. ECCP1 output P1B.
RE7/AD15/ECCP2/P2A RE7 AD15 ⁽³⁾ ECCP2 ⁽⁵⁾ P2A ⁽⁵⁾	59	73	I/O I/O I/O O	ST TTL ST —	Digital I/O. External memory address/data 15. Enhanced Capture 2 input, Compare 2 output, PWM 2 output. ECCP2 output P2A.

Legend: TTL = TTL compatible input
ST = Schmitt Trigger input with CMOS levels
I = Input
P = Power
CMOS = CMOS compatible input or output
Analog = Analog input
O = Output
OD = Open-Drain (no P diode to VDD)

- Note 1:** Alternate assignment for ECCP2/P2A in PIC18F8525/8621 devices when CCP2MX (CONFIG3H<0>) is not set (all Program Memory modes except Microcontroller).
- 2:** Default assignment for ECCP2/P2A when CCP2MX is set (all devices).
- 3:** External memory interface functions are only available on PIC18F8525/8621 devices.
- 4:** Default assignment for P1B/P1C/P3B/P3C for PIC18F8525/8621 devices when ECCPMX (CONFIG3H<1>) is set and for all PIC18F6525/6621 devices.
- 5:** Alternate assignment for ECCP2/P2A in PIC18F8525/8621 devices when CCP2MX is not set (Microcontroller mode).
- 6:** PORTH and PORTJ (and their multiplexed functions) are only available on PIC18F8525/8621 devices.
- 7:** Alternate assignment for P1B/P1C/P3B/P3C for PIC18F8525/8621 devices when ECCPMX (CONFIG3H<1>) is not set.
- 8:** AVDD must be connected to a positive supply and AVSS must be connected to a ground reference for proper operation of the part in user or ICSP™ modes. See parameter D001 for details.
- 9:** RG5 is multiplexed with \overline{MCLR} and is only available when the \overline{MCLR} Resets are disabled.

PIC18F6525/6621/8525/8621

TABLE 1-2: PIC18F6525/6621/8525/8621 PINOUT I/O DESCRIPTIONS (CONTINUED)

Pin Name	Pin Number		Pin Type	Buffer Type	Description
	PIC18F6X2X	PIC18F8X2X			
RF0/AN5 RF0 AN5	18	24	I/O I	ST Analog	PORTF is a bidirectional I/O port. Digital I/O. Analog input 5.
RF1/AN6/C2OUT RF1 AN6 C2OUT	17	23	I/O I O	ST Analog ST	Digital I/O. Analog input 6. Comparator 2 output.
RF2/AN7/C1OUT RF2 AN7 C1OUT	16	18	I/O I O	ST Analog ST	Digital I/O. Analog input 7. Comparator 1 output.
RF3/AN8 RF1 AN8	15	17	I/O I	ST Analog	Digital I/O. Analog input 8.
RF4/AN9 RF1 AN9	14	16	I/O I	ST Analog	Digital I/O. Analog input 9.
RF5/AN10/CVREF RF1 AN10 CVREF	13	15	I/O I O	ST Analog Analog	Digital I/O. Analog input 10. Comparator VREF output.
RF6/AN11 RF6 AN11	12	14	I/O I	ST Analog	Digital I/O. Analog input 11.
RF7/SS RF7 SS	11	13	I/O I	ST TTL	Digital I/O. SPI™ slave select input.

Legend: TTL = TTL compatible input
 ST = Schmitt Trigger input with CMOS levels
 I = Input
 P = Power
 CMOS = CMOS compatible input or output
 Analog = Analog input
 O = Output
 OD = Open-Drain (no P diode to VDD)

- Note 1:** Alternate assignment for ECCP2/P2A in PIC18F8525/8621 devices when CCP2MX (CONFIG3H<0>) is not set (all Program Memory modes except Microcontroller).
- 2:** Default assignment for ECCP2/P2A when CCP2MX is set (all devices).
- 3:** External memory interface functions are only available on PIC18F8525/8621 devices.
- 4:** Default assignment for P1B/P1C/P3B/P3C for PIC18F8525/8621 devices when ECCPMX (CONFIG3H<1>) is set and for all PIC18F6525/6621 devices.
- 5:** Alternate assignment for ECCP2/P2A in PIC18F8525/8621 devices when CCP2MX is not set (Microcontroller mode).
- 6:** PORTH and PORTJ (and their multiplexed functions) are only available on PIC18F8525/8621 devices.
- 7:** Alternate assignment for P1B/P1C/P3B/P3C for PIC18F8525/8621 devices when ECCPMX (CONFIG3H<1>) is not set.
- 8:** AVDD must be connected to a positive supply and AVSS must be connected to a ground reference for proper operation of the part in user or ICSP™ modes. See parameter D001 for details.
- 9:** RG5 is multiplexed with MCLR and is only available when the MCLR Resets are disabled.

PIC18F6525/6621/8525/8621

TABLE 1-2: PIC18F6525/6621/8525/8621 PINOUT I/O DESCRIPTIONS (CONTINUED)

Pin Name	Pin Number		Pin Type	Buffer Type	Description
	PIC18F6X2X	PIC18F8X2X			
RG0/ECCP3/P3A RG0 ECCP3 P3A	3	5	I/O I/O O	ST ST —	PORTG is a bidirectional I/O port. Digital I/O. Enhanced Capture 3 input, Compare 3 output, PWM 3 output. ECCP3 output P3A.
RG1/TX2/CK2 RG1 TX2 CK2	4	6	I/O O I/O	ST — ST	Digital I/O. USART2 asynchronous transmit. USART2 synchronous clock (see RX2/DT2).
RG2/RX2/DT2 RG2 RX2 DT2	5	7	I/O I I/O	ST ST ST	Digital I/O. USART2 asynchronous receive. USART2 synchronous data (see TX2/CK2).
RG3/CCP4/P3D RG3 CCP4 P3D	6	8	I/O I/O O	ST ST —	Digital I/O. Capture 4 input, Compare 4 output, PWM 4 output. ECCP3 output P3D.
RG4/CCP5/P1D RG4 CCP5 P1D	8	10	I/O I/O O	ST ST —	Digital I/O. Capture 5 input, Compare 5 output, PWM 5 output. ECCP1 output P1D.
RG5	7	9	—	—	See $\overline{\text{MCLR}}$ / $\overline{\text{VPP}}$ /RG5 pin.

Legend: TTL = TTL compatible input
 ST = Schmitt Trigger input with CMOS levels
 I = Input
 P = Power
 CMOS = CMOS compatible input or output
 Analog = Analog input
 O = Output
 OD = Open-Drain (no P diode to VDD)

- Note 1:** Alternate assignment for ECCP2/P2A in PIC18F8525/8621 devices when CCP2MX (CONFIG3H<0>) is not set (all Program Memory modes except Microcontroller).
- 2:** Default assignment for ECCP2/P2A when CCP2MX is set (all devices).
- 3:** External memory interface functions are only available on PIC18F8525/8621 devices.
- 4:** Default assignment for P1B/P1C/P3B/P3C for PIC18F8525/8621 devices when ECCPMX (CONFIG3H<1>) is set and for all PIC18F6525/6621 devices.
- 5:** Alternate assignment for ECCP2/P2A in PIC18F8525/8621 devices when CCP2MX is not set (Microcontroller mode).
- 6:** PORTH and PORTJ (and their multiplexed functions) are only available on PIC18F8525/8621 devices.
- 7:** Alternate assignment for P1B/P1C/P3B/P3C for PIC18F8525/8621 devices when ECCPMX (CONFIG3H<1>) is not set.
- 8:** AVDD must be connected to a positive supply and AVSS must be connected to a ground reference for proper operation of the part in user or ICSP™ modes. See parameter D001 for details.
- 9:** RG5 is multiplexed with $\overline{\text{MCLR}}$ and is only available when the $\overline{\text{MCLR}}$ Resets are disabled.

PIC18F6525/6621/8525/8621

TABLE 1-2: PIC18F6525/6621/8525/8621 PINOUT I/O DESCRIPTIONS (CONTINUED)

Pin Name	Pin Number		Pin Type	Buffer Type	Description
	PIC18F6X2X	PIC18F8X2X			
RH0/A16	—	79	I/O	ST	PORTH is a bidirectional I/O port ⁽⁶⁾ . Digital I/O. External memory address 16.
RH0 A16			O	TTL	
RH1/A17	—	80	I/O	ST	Digital I/O. External memory address 17.
RH1 A17			O	TTL	
RH2/A18	—	1	I/O	ST	Digital I/O. External memory address 18.
RH2 A18			O	TTL	
RH3/A19	—	2	I/O	ST	Digital I/O. External memory address 19.
RH3 A19			O	TTL	
RH4/AN12/P3C	—	22	I/O	ST	Digital I/O. Analog input 12. ECCP3 output P3C.
RH4 AN12 P3C ⁽⁷⁾			I O	Analog —	
RH5/AN13/P3B	—	21	I/O	ST	Digital I/O. Analog input 13. ECCP3 output P3B.
RH5 AN13 P3B ⁽⁷⁾			I O	Analog —	
RH6/AN14/P1C	—	20	I/O	ST	Digital I/O. Analog input 14. ECCP1 output P1C.
RH6 AN14 P1C ⁽⁷⁾			I O	Analog —	
RH7/AN15/P1B	—	19	I/O	ST	Digital I/O. Analog input 15. ECCP1 output P1B.
RH7 AN15 P1B ⁽⁷⁾			I O	Analog —	

Legend: TTL = TTL compatible input
 ST = Schmitt Trigger input with CMOS levels
 I = Input
 P = Power
 CMOS = CMOS compatible input or output
 Analog = Analog input
 O = Output
 OD = Open-Drain (no P diode to VDD)

- Note 1:** Alternate assignment for ECCP2/P2A in PIC18F8525/8621 devices when CCP2MX (CONFIG3H<0>) is not set (all Program Memory modes except Microcontroller).
- 2:** Default assignment for ECCP2/P2A when CCP2MX is set (all devices).
- 3:** External memory interface functions are only available on PIC18F8525/8621 devices.
- 4:** Default assignment for P1B/P1C/P3B/P3C for PIC18F8525/8621 devices when ECCPMX (CONFIG3H<1>) is set and for all PIC18F6525/6621 devices.
- 5:** Alternate assignment for ECCP2/P2A in PIC18F8525/8621 devices when CCP2MX is not set (Microcontroller mode).
- 6:** PORTH and PORTJ (and their multiplexed functions) are only available on PIC18F8525/8621 devices.
- 7:** Alternate assignment for P1B/P1C/P3B/P3C for PIC18F8525/8621 devices when ECCPMX (CONFIG3H<1>) is not set.
- 8:** AVDD must be connected to a positive supply and AVSS must be connected to a ground reference for proper operation of the part in user or ICSP™ modes. See parameter D001 for details.
- 9:** RG5 is multiplexed with MCLR and is only available when the MCLR Resets are disabled.

PIC18F6525/6621/8525/8621

TABLE 1-2: PIC18F6525/6621/8525/8621 PINOUT I/O DESCRIPTIONS (CONTINUED)

Pin Name	Pin Number		Pin Type	Buffer Type	Description
	PIC18F6X2X	PIC18F8X2X			
RJ0/ALE RJ0 ALE	—	62	I/O O	ST TTL	PORTJ is a bidirectional I/O port ⁽⁶⁾ . Digital I/O. External memory address latch enable.
RJ1/OE RJ1 OE	—	61	I/O O	ST TTL	Digital I/O. External memory output enable.
RJ2/WRL RJ2 WRL	—	60	I/O O	ST TTL	Digital I/O. External memory write low control.
RJ3/WRH RJ3 WRH	—	59	I/O O	ST TTL	Digital I/O. External memory write high control.
RJ4/BA0 RJ4 BA0	—	39	I/O O	ST TTL	Digital I/O. System bus byte address 0 control.
RJ5/CE RJ5 CE	—	40	I/O O	ST TTL	Digital I/O External memory access indicator.
RJ6/LB RJ6 LB	—	41	I/O O	ST TTL	Digital I/O. External memory low byte select.
RJ7/UB RJ7 UB	—	42	I/O O	ST TTL	Digital I/O. External memory high byte select.
VSS	9, 25, 41, 56	11, 31, 51, 70	P	—	Ground reference for logic and I/O pins.
VDD	10, 26, 38, 57	12, 32, 48, 71	P	—	Positive supply for logic and I/O pins.
AVSS ⁽⁸⁾	20	26	P	—	Ground reference for analog modules.
AVDD ⁽⁸⁾	19	25	P	—	Positive supply for analog modules.

Legend: TTL = TTL compatible input

ST = Schmitt Trigger input with CMOS levels

I = Input

P = Power

CMOS = CMOS compatible input or output

Analog = Analog input

O = Output

OD = Open-Drain (no P diode to VDD)

Note 1: Alternate assignment for ECCP2/P2A in PIC18F8525/8621 devices when CCP2MX (CONFIG3H<0>) is not set (all Program Memory modes except Microcontroller).

2: Default assignment for ECCP2/P2A when CCP2MX is set (all devices).

3: External memory interface functions are only available on PIC18F8525/8621 devices.

4: Default assignment for P1B/P1C/P3B/P3C for PIC18F8525/8621 devices when ECCPMX (CONFIG3H<1>) is set and for all PIC18F6525/6621 devices.

5: Alternate assignment for ECCP2/P2A in PIC18F8525/8621 devices when CCP2MX is not set (Microcontroller mode).

6: PORTH and PORTJ (and their multiplexed functions) are only available on PIC18F8525/8621 devices.

7: Alternate assignment for P1B/P1C/P3B/P3C for PIC18F8525/8621 devices when ECCPMX (CONFIG3H<1>) is not set.

8: AVDD must be connected to a positive supply and AVSS must be connected to a ground reference for proper operation of the part in user or ICSP™ modes. See parameter D001 for details.

9: RG5 is multiplexed with MCLR and is only available when the MCLR Resets are disabled.

PIC18F6525/6621/8525/8621

2.0 OSCILLATOR CONFIGURATIONS

2.1 Oscillator Types

The PIC18F6525/6621/8525/8621 devices can be operated in twelve different oscillator modes. The user can program four configuration bits (FOSC3, FOSC2, FOSC1 and FOSC0) to select one of these eight modes:

1. LP Low-Power Crystal
2. XT Crystal/Resonator
3. HS High-Speed Crystal/Resonator
4. RC External Resistor/Capacitor
5. EC External Clock
6. ECIO External Clock with I/O pin enabled
7. HS+PLL High-Speed Crystal/Resonator with PLL enabled
8. RCIO External Resistor/Capacitor with I/O pin enabled
9. ECIO+SPLL External Clock with software controlled PLL
10. ECIO+PLL External Clock with PLL and I/O pin enabled
11. HS+SPLL High-Speed Crystal/Resonator with software control
12. RCIO External Resistor/Capacitor with I/O pin enabled

2.2 Crystal Oscillator/Ceramic Resonators

In XT, LP, HS, HS+PLL or HS+SPLL Oscillator modes, a crystal or ceramic resonator is connected to the OSC1 and OSC2 pins to establish oscillation. Figure 2-1 shows the pin connections.

The PIC18F6525/6621/8525/8621 oscillator design requires the use of a parallel cut crystal.

Note: Use of a series cut crystal may give a frequency out of the crystal manufacturers specifications.

FIGURE 2-1: CRYSTAL/CERAMIC RESONATOR OPERATION (HS, XT OR LP CONFIGURATION)

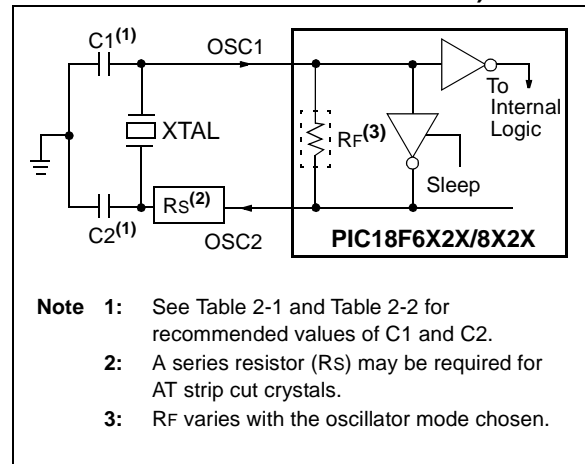

TABLE 2-1: CAPACITOR SELECTION FOR CERAMIC RESONATORS

Ranges Tested:			
Mode	Freq	C1	C2
XT	455 kHz	68-100 pF	68-100 pF
	2.0 MHz	15-68 pF	15-68 pF
	4.0 MHz	15-68 pF	15-68 pF
HS	8.0 MHz	10-68 pF	10-68 pF
	16.0 MHz	10-22 pF	10-22 pF

These values are for design guidance only.
See notes following this table.

Resonators Used:	
2 kHz	8 MHz
4 MHz	16 MHz

- Note 1:** Higher capacitance increases the stability of the oscillator but also increases the start-up time.
- Note 2:** When operating below 3V VDD, or when using certain ceramic resonators at any voltage, it may be necessary to use high gain HS mode, try a lower frequency resonator or switch to a crystal oscillator.
- Note 3:** Since each resonator/crystal has its own characteristics, the user should consult the resonator/crystal manufacturer for appropriate values of external components or verify oscillator performance.

PIC18F6525/6621/8525/8621

TABLE 2-2: CAPACITOR SELECTION FOR CRYSTAL OSCILLATOR

Ranges Tested:			
Mode	Freq	C1	C2
LP	32.0 kHz	33 pF	33 pF
XT	200 kHz	47-68 pF	47-68 pF
	1.0 MHz	15 pF	15 pF
	4.0 MHz	15 pF	15 pF
HS	4.0 MHz	15 pF	15 pF
	8.0 MHz	15-33 pF	15-33 pF
	20.0 MHz	15-33 pF	15-33 pF
	25.0 MHz	15-33 pF	15-33 pF
These values are for design guidance only. See notes following this table.			
Crystals Used			
32 kHz		4 MHz	
200 kHz		8 MHz	
1 MHz		20 MHz	

Note 1: Higher capacitance increases the stability of the oscillator but also increases the start-up time.

2: R_s (see Figure 2-1) may be required in HS mode, as well as XT mode, to avoid overdriving crystals with low drive level specification.

3: Since each resonator/crystal has its own characteristics, the user should consult the resonator/crystal manufacturer for appropriate values of external components or verify oscillator performance.

An external clock source may also be connected to the OSC1 pin in the HS, XT and LP modes as shown in Figure 2-2.

FIGURE 2-2: EXTERNAL CLOCK INPUT OPERATION (HS, XT OR LP OSCILLATOR CONFIGURATION)

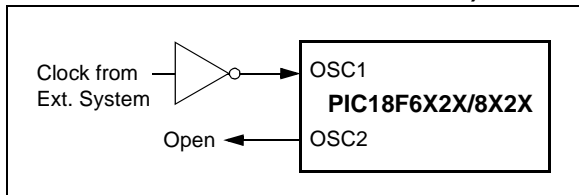

2.3 RC Oscillator

For timing insensitive applications, the "RC" and "RCIO" device options offer additional cost savings. The RC oscillator frequency is a function of the supply voltage, the resistor (R_{EXT}) and capacitor (C_{EXT}) values and the operating temperature. In addition to this, the oscillator frequency will vary from unit to unit due to normal process parameter variation. Furthermore, the difference in lead frame capacitance between package types will also affect the oscillation frequency, especially for low C_{EXT} values. The user also needs to take into account variation due to tolerance of external R and C components used. Figure 2-3 shows how the R/C combination is connected.

In the RC Oscillator mode, the oscillator frequency divided by 4 is available on the OSC2 pin. This signal may be used for test purposes or to synchronize other logic.

FIGURE 2-3: RC OSCILLATOR MODE

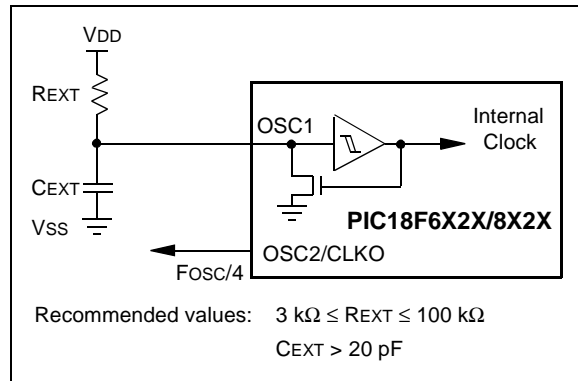

The RCIO Oscillator mode functions like the RC mode except that the OSC2 pin becomes an additional general purpose I/O pin. The I/O pin becomes bit 6 of PORTA (RA6).

2.4 External Clock Input

The EC, ECIO, EC+PLL and EC+SPLL Oscillator modes require an external clock source to be connected to the OSC1 pin. The feedback device between OSC1 and OSC2 is turned off in these modes to save current. There is a maximum 1.5 μ s start-up required after a Power-on Reset or wake-up from Sleep mode.

In the EC Oscillator mode, the oscillator frequency divided by 4 is available on the OSC2 pin. This signal may be used for test purposes or to synchronize other logic. Figure 2-4 shows the pin connections for the EC Oscillator mode.

FIGURE 2-4: EXTERNAL CLOCK INPUT OPERATION (EC CONFIGURATION)

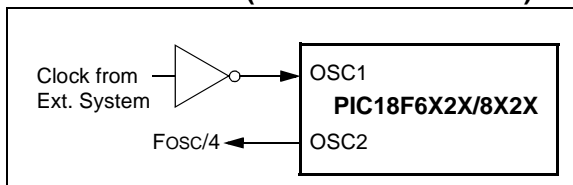

The ECIO Oscillator mode functions like the EC mode except that the OSC2 pin becomes an additional general purpose I/O pin. The I/O pin becomes bit 6 of PORTA (RA6). Figure 2-5 shows the pin connections for the ECIO Oscillator mode.

FIGURE 2-5: EXTERNAL CLOCK INPUT OPERATION (ECIO CONFIGURATION)

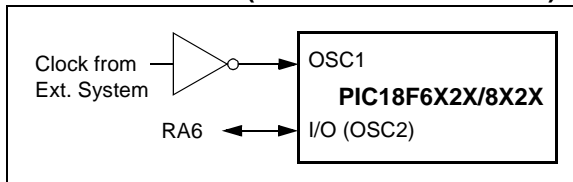
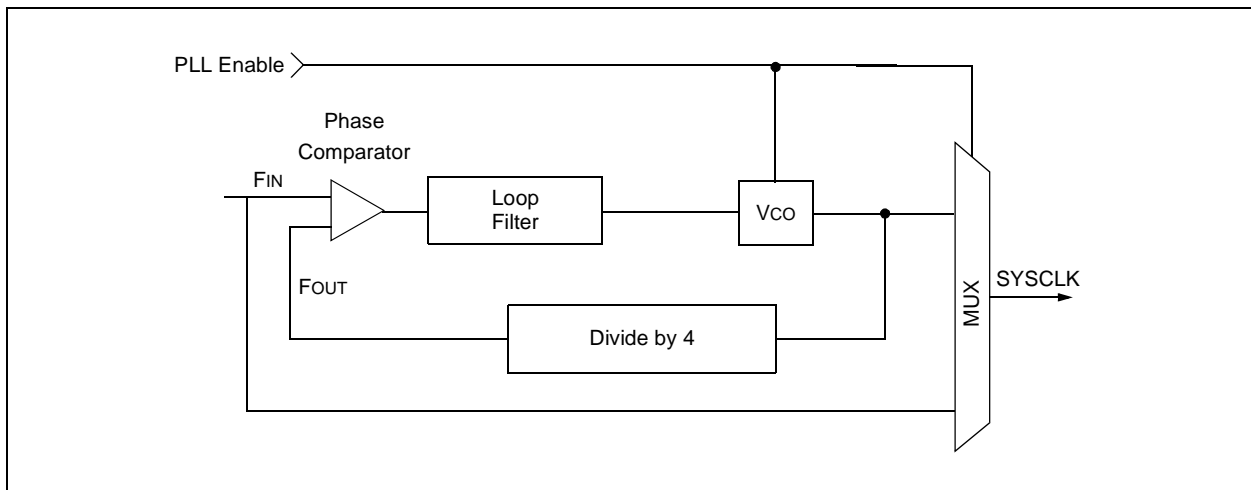

FIGURE 2-6: PLL BLOCK DIAGRAM



2.5 Phase Locked Loop (PLL)

A Phase Locked Loop circuit is provided as a programmable option for users that want to multiply the frequency of the incoming oscillator signal by 4. For an input clock frequency of 10 MHz, the internal clock frequency will be multiplied to 40 MHz. This is useful for customers who are concerned with EMI due to high-frequency crystals.

The PLL can only be enabled when the oscillator configuration bits are programmed for High-Speed Oscillator or External Clock mode. If they are programmed for any other mode, the PLL is not enabled and the system clock will come directly from OSC1. There are two types of PLL modes: Software Controlled PLL and Configuration Bits Controlled PLL. In Software Controlled PLL mode, PIC18F6525/6621/8525/8621 executes at regular clock frequency after all Reset conditions. During execution, the application can enable PLL and switch to 4x clock frequency operation by setting the PLEN bit in the OSCCON register. In Configuration Bits Controlled PLL, the PLL operation cannot be changed “on-the-fly”. To enable or disable it, the controller must either cycle through a Power-on Reset, or switch the clock source from the main oscillator to the Timer1 oscillator and back again (see **Section 2.6 “Oscillator Switching Feature”** for details).

The type of PLL is selected by programming FOSC<3:0> configuration bits in the CONFIG1H Configuration register. The oscillator mode is specified during device programming.

A PLL lock timer is used to ensure that the PLL has locked before device execution starts. The PLL lock timer has a time-out that is called TPLL.

PIC18F6525/6621/8525/8621

2.6 Oscillator Switching Feature

The PIC18F6525/6621/8525/8621 devices include a feature that allows the system clock source to be switched from the main oscillator to an alternate low frequency clock source. For the PIC18F6525/6621/8525/8621 devices, this alternate clock source is the Timer1 oscillator. If a low-frequency crystal (32 kHz, for example) has been attached to the Timer1 oscillator pins and the Timer1 oscillator has been enabled, the device can switch to a low-power execution mode.

Figure 2-7 shows a block diagram of the system clock sources. The clock switching feature is enabled by programming the Oscillator Switching Enable (OSCSN) bit in the CONFIG1H Configuration register to a '0'. Clock switching is disabled in an erased device. See **Section 12.0 "Timer1 Module"** for further details of the Timer1 oscillator. See **Section 24.0 "Special Features of the CPU"** for Configuration register details.

FIGURE 2-7: DEVICE CLOCK SOURCES

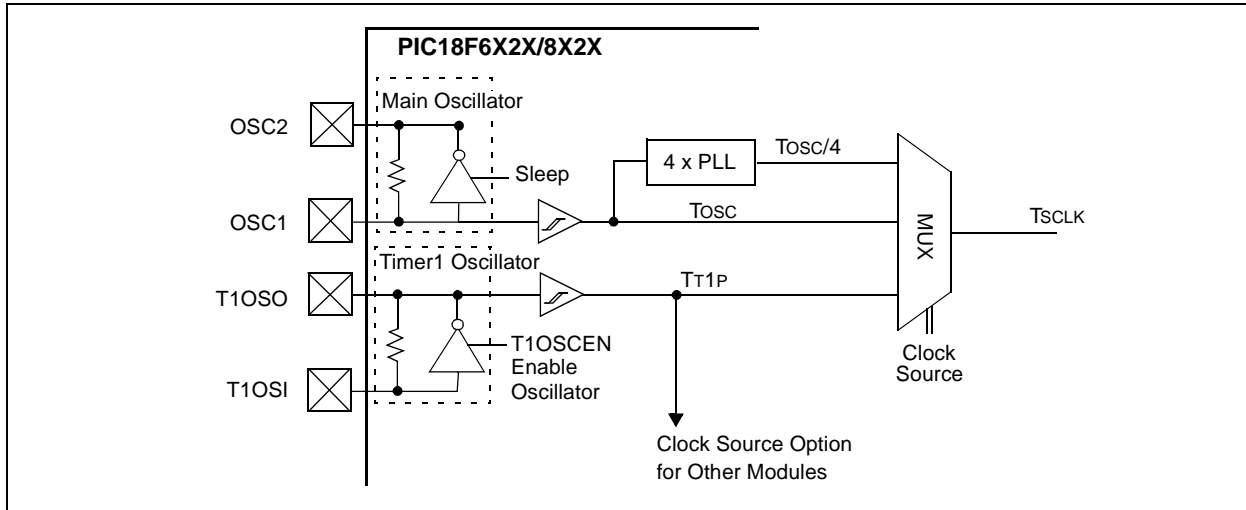

PIC18F6525/6621/8525/8621

2.6.1 SYSTEM CLOCK SWITCH BIT

The system clock source switching is performed under software control. The system clock switch bits, SCS1:SCS0 (OSCCON<1:0>), control the clock switching. When the SCS0 bit is '0', the system clock source comes from the main oscillator that is selected by the FOSC configuration bits in the CONFIG1H Configuration register. When the SCS0 bit is set, the system clock source will come from the Timer1 oscillator. The SCS0 bit is cleared on all forms of Reset.

When the FOSC bits are programmed for Software PLL mode, the SCS1 bit can be used to select between primary oscillator/clock and PLL output. The SCS1 bit will only have an effect on the system clock if the PLL is enabled (PLLEN = 1) and locked (LOCK = 1), else it will be forced cleared. When programmed with Configuration Controlled PLL, the SCS1 bit will be forced clear.

Note: The Timer1 oscillator must be enabled and operating to switch the system clock source. The Timer1 oscillator is enabled by setting the T1OSCEN bit in the Timer1 Control register (T1CON). If the Timer1 oscillator is not enabled, then any write to the SCS0 bit will be ignored (SCS0 bit forced cleared) and the main oscillator will continue to be the system clock source.

REGISTER 2-1: OSCCON: OSCILLATOR CONTROL REGISTER

U-0	U-0	U-0	U-0	R/W-0	R/W-0	R/W-0	R/W-0
—	—	—	—	LOCK	PLLEN ⁽¹⁾	SCS1	SCS0 ⁽²⁾
bit 7				bit 0			

bit 7-4 **Unimplemented:** Read as '0'

bit 3 **LOCK:** Phase Lock Loop Lock Status bit

1 = Phase Lock Loop output is stable as system clock

0 = Phase Lock Loop output is not stable and output cannot be used as system clock

bit 2 **PLLEN:** Phase Lock Loop Enable bit⁽¹⁾

1 = Enable Phase Lock Loop output as system clock

0 = Disable Phase Lock Loop

bit 1 **SCS1:** System Clock Switch bit 1

When PLLEN and LOCK bits are set:

1 = Use PLL output

0 = Use primary oscillator/clock input pin

When PLLEN or LOCK bit is cleared:

Bit is forced clear.

bit 0 **SCS0:** System Clock Switch bit 0⁽²⁾

When OSCSEN configuration bit = 0 and T1OSCEN bit = 1:

1 = Switch to Timer1 oscillator/clock pin

0 = Use primary oscillator/clock input pin

When OSCSEN and T1OSCEN are in other states:

Bit is forced clear.

Note 1: PLLEN bit is forced set when configured for ECIO+PLL and HS+PLL modes. This bit is writable for ECIO+SPLL and HS+SPLL modes only; forced cleared for all other oscillator modes.

2: The setting of SCS0 = 1 supersedes SCS1 = 1.

Legend:

R = Readable bit

W = Writable bit

U = Unimplemented bit, read as '0'

-n = Value at POR

'1' = Bit is set

'0' = Bit is cleared

x = Bit is unknown

PIC18F6525/6621/8525/8621

2.6.2 OSCILLATOR TRANSITIONS

PIC18F6525/6621/8525/8621 devices contain circuitry to prevent “glitches” when switching between oscillator sources. Essentially, the circuitry waits for eight rising edges of the clock source that the processor is switching to. This ensures that the new clock source is stable and that its pulse width will not be less than the shortest pulse width of the two clock sources.

A timing diagram indicating the transition from the main oscillator to the Timer1 oscillator is shown in Figure 2-8. The Timer1 oscillator is assumed to be running all the time. After the SCS0 bit is set, the processor is frozen at the next occurring Q1 cycle. After eight synchronization cycles are counted from the Timer1 oscillator, operation resumes. No additional delays are required after the synchronization cycles.

FIGURE 2-8: TIMING DIAGRAM FOR TRANSITION FROM OSC1 TO TIMER1 OSCILLATOR

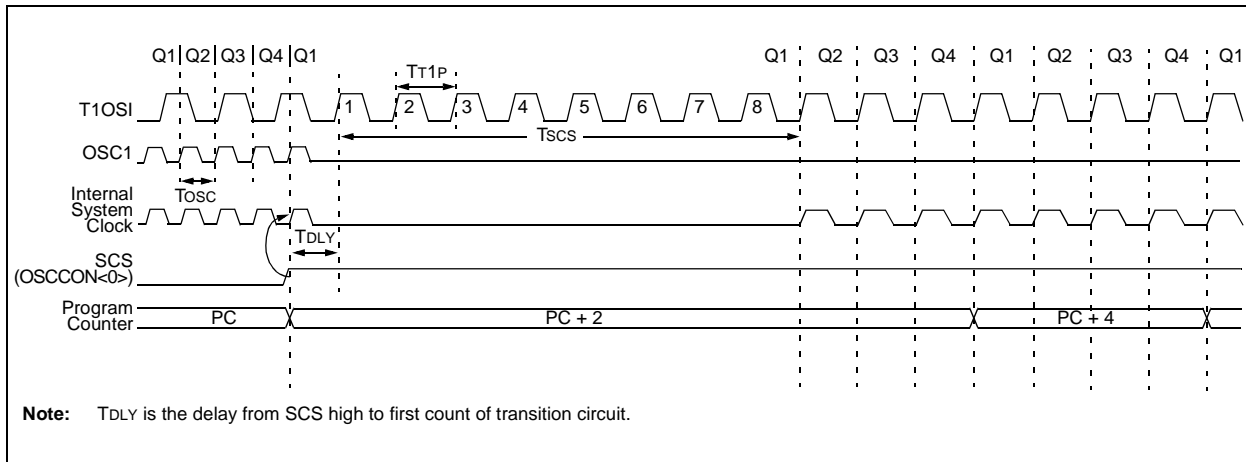

The sequence of events that takes place when switching from the Timer1 oscillator to the main oscillator will depend on the mode of the main oscillator. In addition to eight clock cycles of the main oscillator, additional delays may take place.

If the main oscillator is configured for an external crystal (HS, XT, LP), then the transition will take place after an oscillator start-up time (T_{OST}) has occurred. A timing diagram, indicating the transition from the Timer1 oscillator to the main oscillator for HS, XT and LP modes, is shown in Figure 2-9.

FIGURE 2-9: TIMING FOR TRANSITION BETWEEN TIMER1 AND OSC1 (HS, XT, LP)

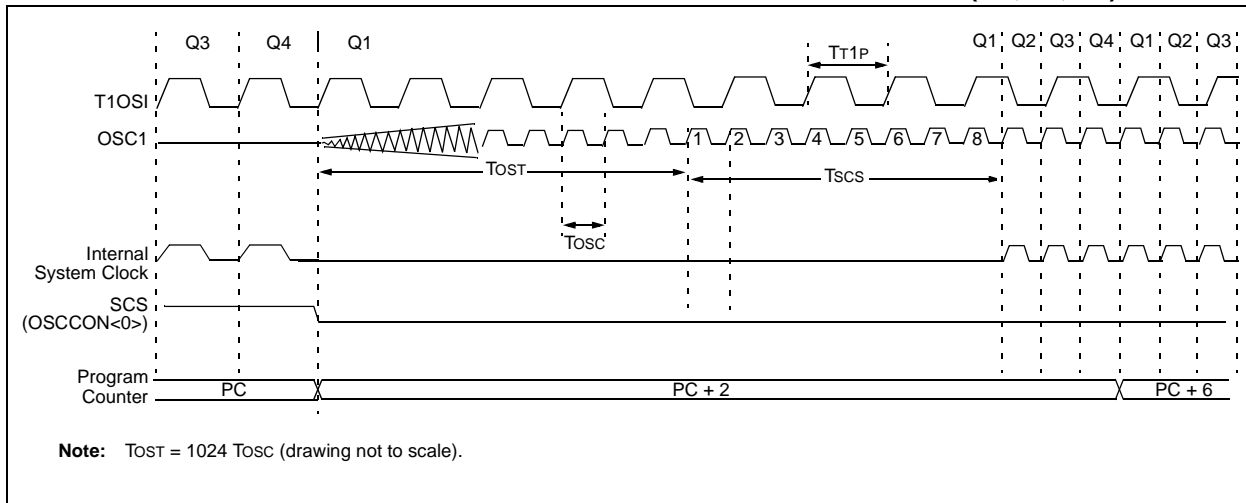

PIC18F6525/6621/8525/8621

If the main oscillator is configured for HS mode with PLL active, an oscillator start-up time (T_{OST}) plus an additional PLL time-out (T_{PLL}) will occur. The PLL time-out is typically 2 ms and allows the PLL to lock to the main oscillator frequency. A timing diagram, indicating the transition from the Timer1 oscillator to the main oscillator for HS+PLL mode, is shown in Figure 2-10.

FIGURE 2-10: TIMING FOR TRANSITION BETWEEN TIMER1 AND OSC1 (HS WITH PLL ACTIVE, SCS1 = 1)

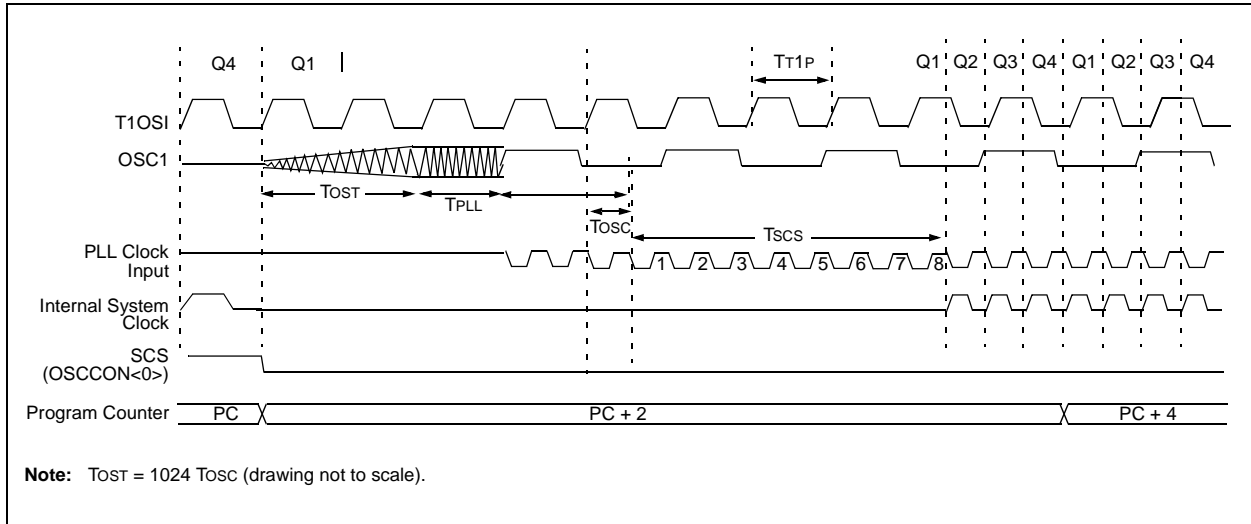

If the main oscillator is configured for EC mode with PLL active, only PLL time-out (T_{PLL}) will occur. The PLL time-out is typically 2 ms and allows the PLL to lock to the main oscillator frequency. A timing diagram, indicating the transition from the Timer1 oscillator to the main oscillator for EC with PLL active, is shown in Figure 2-11.

FIGURE 2-11: TIMING FOR TRANSITION BETWEEN TIMER1 AND OSC1 (EC WITH PLL ACTIVE, SCS1 = 1)

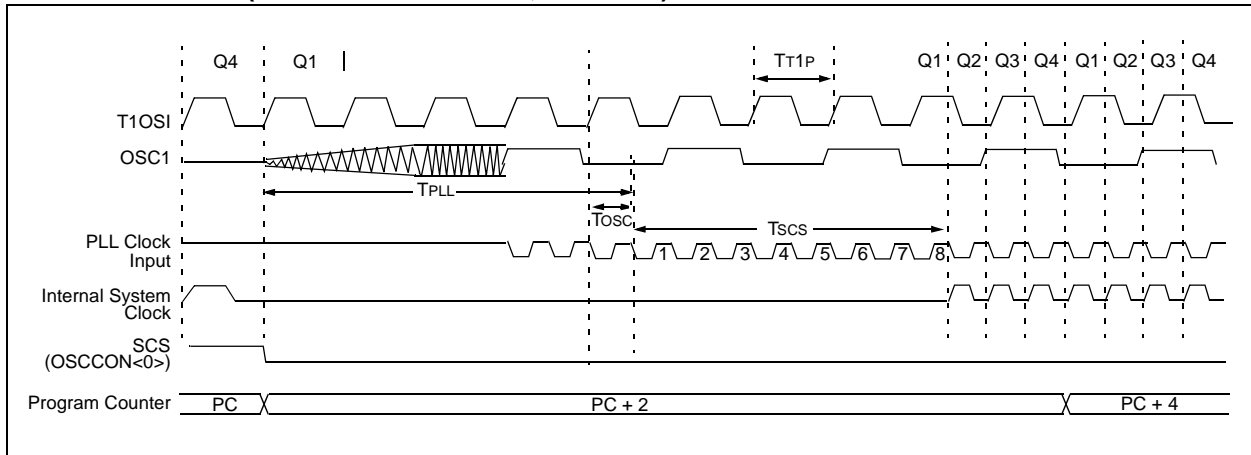

PIC18F6525/6621/8525/8621

If the main oscillator is configured in the RC, RCIO, EC or ECIO modes, there is no oscillator start-up time-out. Operation will resume after eight cycles of the main oscillator have been counted. A timing diagram, indicating the transition from the Timer1 oscillator to the main oscillator for RC, RCIO, EC and ECIO modes, is shown in Figure 2-12.

FIGURE 2-12: TIMING FOR TRANSITION BETWEEN TIMER1 AND OSC1 (RC, EC)

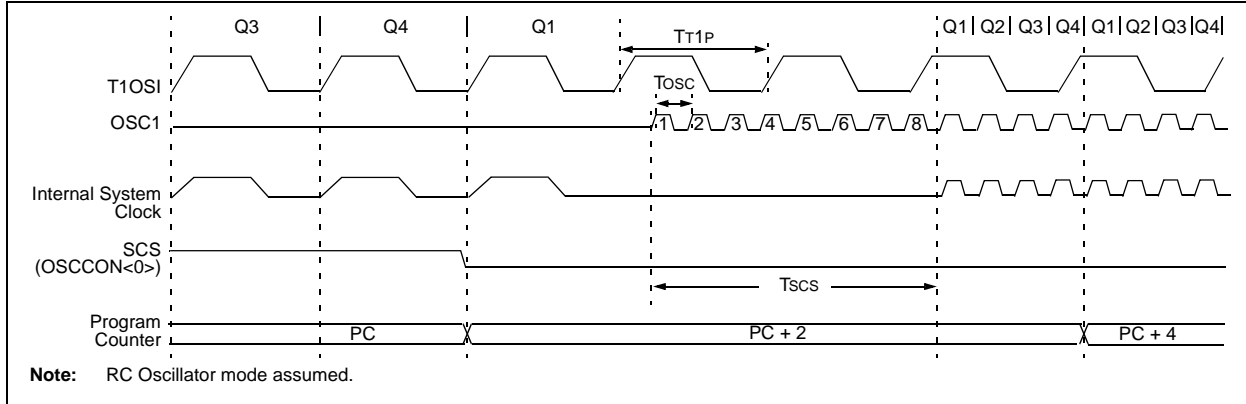

2.7 Effects of Sleep Mode on the On-Chip Oscillator

When the device executes a SLEEP instruction, the on-chip clocks and oscillator are turned off and the device is held at the beginning of an instruction cycle (Q1 state). With the oscillator off, the OSC1 and OSC2 signals will stop oscillating. Since all the transistor

switching currents have been removed, Sleep mode achieves the lowest current consumption of the device (only leakage currents). Enabling any on-chip feature that will operate during Sleep will increase the current consumed during Sleep. The user can wake from Sleep through external Reset, Watchdog Timer Reset, or through an interrupt.

TABLE 2-3: OSC1 AND OSC2 PIN STATES IN SLEEP MODE

Oscillator Mode	OSC1 Pin	OSC2 Pin
RC	Floating, external resistor should pull high	At logic low
RCIO	Floating, external resistor should pull high	Configured as PORTA, bit 6
ECIO	Floating	Configured as PORTA, bit 6
EC	Floating	At logic low
LP, XT and HS	Feedback inverter disabled at quiescent voltage level	Feedback inverter disabled at quiescent voltage level

Note: See Table 3-1 in Section 3.0 "Reset" for time-outs due to Sleep and MCLR Reset.

2.8 Power-up Delays

Power-up delays are controlled by two timers so that no external Reset circuitry is required for most applications. The delays ensure that the device is kept in Reset until the device power supply and clock are stable. For additional information on Reset operation, see Section 3.0 "Reset".

The first timer is the Power-up Timer (PWRT) which optionally provides a fixed delay of 72 ms (nominal) on power-up only (POR and BOR). The second timer is the Oscillator Start-up Timer (OST), intended to keep the chip in Reset until the crystal oscillator is stable.

With the PLL enabled (HS+PLL and EC+PLL oscillator mode), the time-out sequence following a Power-on Reset is different from other oscillator modes. The time-out sequence is as follows: First, the PWRT time-out is invoked after a POR time delay has expired. Then, the Oscillator Start-up Timer (OST) is invoked. However, this is still not a sufficient amount of time to allow the PLL to lock at high frequencies. The PWRT timer is used to provide an additional fixed 2 ms (nominal) time-out to allow the PLL ample time to lock to the incoming clock frequency.

PIC18F6525/6621/8525/8621

3.0 RESET

The PIC18F6525/6621/8525/8621 devices differentiate between various kinds of Reset:

- Power-on Reset (POR)
- $\overline{\text{MCLR}}$ Reset during normal operation
- $\overline{\text{MCLR}}$ Reset during Sleep
- Watchdog Timer (WDT) Reset (during normal operation)
- Programmable Brown-out Reset (BOR)
- RESET Instruction
- Stack Full Reset
- Stack Underflow Reset

Most registers are unaffected by a Reset. Their status is unknown on POR and unchanged by all other Resets. The other registers are forced to a "Reset state" on Power-on Reset, $\overline{\text{MCLR}}$, WDT Reset, Brown-out Reset, $\overline{\text{MCLR}}$ Reset during Sleep and by the RESET instruction.

Most registers are not affected by a WDT wake-up since this is viewed as the resumption of normal operation. Status bits from the RCON register, $\overline{\text{RI}}$, $\overline{\text{TO}}$, $\overline{\text{PD}}$, $\overline{\text{POR}}$ and $\overline{\text{BOR}}$, are set or cleared differently in different Reset situations as indicated in Table 3-2. These bits are used in software to determine the nature of the Reset. See Table 3-3 for a full description of the Reset states of all registers.

A simplified block diagram of the On-Chip Reset Circuit is shown in Figure 3-1.

The Enhanced MCU devices have a $\overline{\text{MCLR}}$ noise filter in the $\overline{\text{MCLR}}$ Reset path. The filter will detect and ignore small pulses. The $\overline{\text{MCLR}}$ pin is not driven low by any internal Resets, including the WDT.

FIGURE 3-1: SIMPLIFIED BLOCK DIAGRAM OF ON-CHIP RESET CIRCUIT

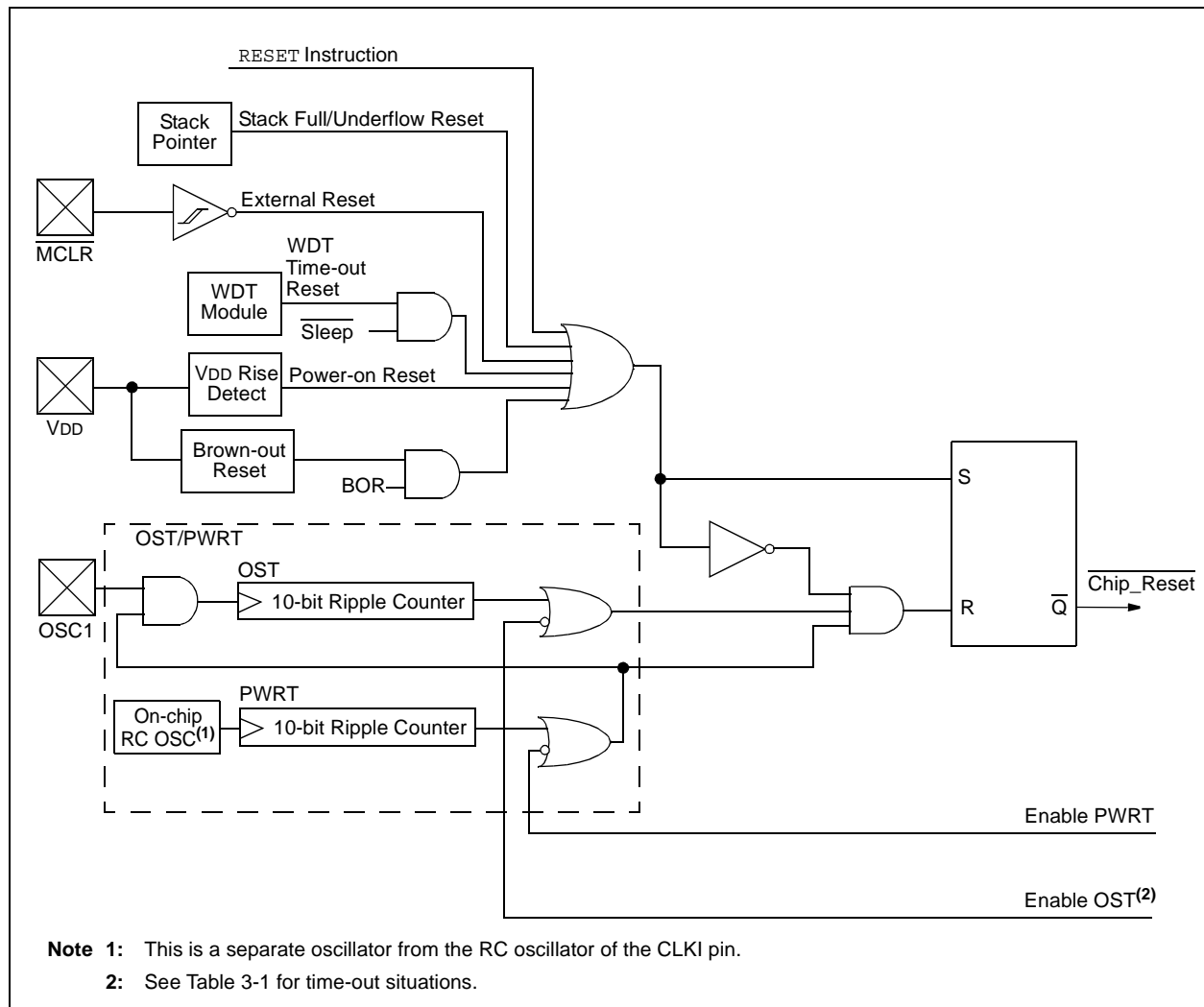

PIC18F6525/6621/8525/8621

3.1 Power-on Reset (POR)

A Power-on Reset pulse is generated on-chip when V_{DD} rise is detected. To take advantage of the POR circuitry, tie the \overline{MCLR} pin through a $1\text{ k}\Omega$ to $10\text{ k}\Omega$ resistor to V_{DD} . This will eliminate external RC components usually needed to create a Power-on Reset delay. A minimum rise rate for V_{DD} is specified (parameter D004). For a slow rise time, see Figure 3-2.

When the device starts normal operation (i.e., exits the Reset condition), device operating parameters (voltage, frequency, temperature, etc.) must be met to ensure operation. If these conditions are not met, the device must be held in Reset until the operating conditions are met.

FIGURE 3-2: EXTERNAL POWER-ON RESET CIRCUIT (FOR SLOW V_{DD} POWER-UP)

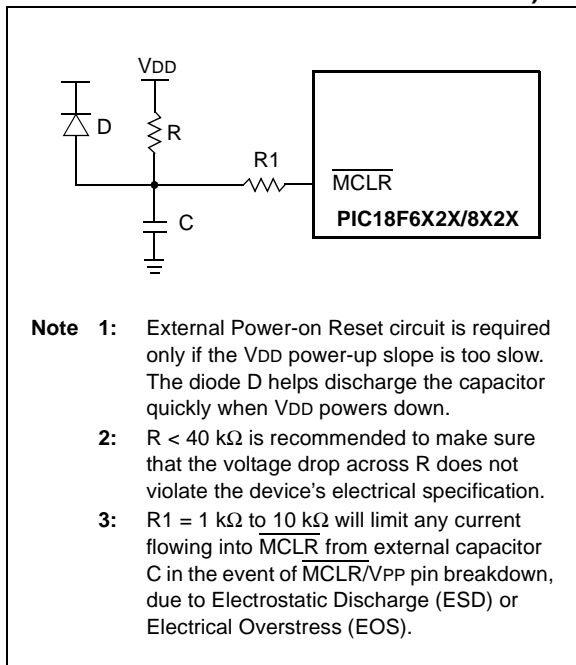

3.2 Power-up Timer (PWRT)

The Power-up Timer provides a fixed nominal time-out (parameter 33) only on power-up from the POR. The Power-up Timer operates on an internal RC oscillator. The chip is kept in Reset as long as the PWRT is active. The PWRT's time delay allows V_{DD} to rise to an acceptable level. A configuration bit is provided to enable/disable the PWRT.

The power-up time delay will vary from chip-to-chip due to V_{DD} , temperature and process variation. See DC parameter 33 for details.

3.3 Oscillator Start-up Timer (OST)

The Oscillator Start-up Timer (OST) provides a 1024 oscillator cycle (from OSC1 input) delays after the PWRT delay is over (parameter 32). This ensures that the crystal oscillator or resonator has started and stabilized.

The OST time-out is invoked only for XT, LP and HS modes and only on Power-on Reset, or wake-up from Sleep.

3.4 PLL Lock Time-out

With the PLL enabled, the time-out sequence following a Power-on Reset is different from other oscillator modes. A portion of the Power-up Timer is used to provide a fixed time-out that is sufficient for the PLL to lock to the main oscillator frequency. This PLL lock time-out (TPLL) is typically 2 ms and follows the oscillator start-up time-out.

3.5 Brown-out Reset (BOR)

A configuration bit, BOR, can disable (if clear/programmed) or enable (if set) the Brown-out Reset circuitry. If V_{DD} falls below parameter D005 for greater than parameter 35, the brown-out situation will reset the chip. A Reset may not occur if V_{DD} falls below parameter D005 for less than parameter 35. The chip will remain in Brown-out Reset until V_{DD} rises above BV_{DD} . If the Power-up Timer is enabled, it will be invoked after V_{DD} rises above BV_{DD} ; it then will keep the chip in Reset for an additional time delay (parameter 33). If V_{DD} drops below BV_{DD} while the Power-up Timer is running, the chip will go back into a Brown-out Reset and the Power-up Timer will be initialized. Once V_{DD} rises above BV_{DD} , the Power-up Timer will execute the additional time delay.

3.6 Time-out Sequence

On power-up, the time-out sequence is as follows: First, PWRT time-out is invoked after the POR time delay has expired. Then, OST is activated. The total time-out will vary based on oscillator configuration and the status of the PWRT. For example, in RC mode with the PWRT disabled, there will be no time-out at all. Figure 3-3, Figure 3-4, Figure 3-5, Figure 3-6 and Figure 3-7 depict time-out sequences on power-up.

Since the time-outs occur from the POR pulse, the time-outs will expire if \overline{MCLR} is kept low long enough. Bringing \overline{MCLR} high will begin execution immediately (Figure 3-5). This is useful for testing purposes or to synchronize more than one PIC18F6525/6621/8525/8621 device operating in parallel.

Table 3-2 shows the Reset conditions for some Special Function Registers, while Table 3-3 shows the Reset conditions for all of the registers.

PIC18F6525/6621/8525/8621

TABLE 3-1: TIME-OUT IN VARIOUS SITUATIONS

Oscillator Configuration	Power-up ⁽²⁾		Brown-out	Wake-up from Sleep or Oscillator Switch
	$\overline{\text{PWRTE}} = 0$	$\overline{\text{PWRTE}} = 1$		
HS with PLL enabled ⁽¹⁾	72 ms + 1024 TOSC + 2 ms	1024 TOSC + 2 ms	72 ms ⁽²⁾ + 1024 TOSC + 2 ms	1024 TOSC + 2 ms
HS, XT, LP	72 ms + 1024 TOSC	1024 TOSC	72 ms ⁽²⁾ + 1024 TOSC	1024 TOSC
EC	72 ms	1.5 μ s	72 ms ⁽²⁾	1.5 μ s ⁽³⁾
External RC	72 ms	—	72 ms ⁽²⁾	—

- Note 1:** 2 ms is the nominal time required for the 4x PLL to lock.
Note 2: 72 ms is the nominal power-up timer delay, if implemented.
Note 3: 1.5 μ s is the recovery time from Sleep. There is no recovery time from oscillator switch.

REGISTER 3-1: RCON REGISTER BITS AND POSITIONS⁽¹⁾

R/W-0	U-0	U-0	R/W-1	R/W-1	R/W-1	R/W-0	R/W-0	
IPEN	—	—	$\overline{\text{RI}}$	$\overline{\text{TO}}$	$\overline{\text{PD}}$	$\overline{\text{POR}}$	$\overline{\text{BOR}}$	
bit 7								bit 0

Note 1: Refer to Section 4.14 “RCON Register” for bit definitions.

TABLE 3-2: STATUS BITS, THEIR SIGNIFICANCE AND THE INITIALIZATION CONDITION FOR RCON REGISTER

Condition	Program Counter	$\overline{\text{RI}}$	$\overline{\text{TO}}$	$\overline{\text{PD}}$	$\overline{\text{POR}}$	$\overline{\text{BOR}}$	STKFUL	STKUNF
Power-on Reset	0000h	1	1	1	0	0	u	u
$\overline{\text{MCLR}}$ Reset during normal operation	0000h	u	u	u	u	u	u	u
Software Reset during normal operation	0000h	0	u	u	u	u	u	u
Stack Full Reset during normal operation	0000h	u	u	u	u	u	u	1
Stack Underflow Reset during normal operation	0000h	u	u	u	u	u	1	u
$\overline{\text{MCLR}}$ Reset during Sleep	0000h	u	1	0	u	u	u	u
WDT Reset	0000h	1	0	1	u	u	u	u
WDT Wake-up	PC + 2	u	0	0	u	u	u	u
Brown-out Reset	0000h	1	1	1	1	0	u	u
Interrupt Wake-up from Sleep	PC + 2 ⁽¹⁾	u	1	0	u	u	u	u

Legend: u = unchanged, x = unknown

Note 1: When the wake-up is due to an interrupt and the GIEH or GIEL bits are set, the PC is loaded with the interrupt vector (0008h or 0018h).

PIC18F6525/6621/8525/8621

TABLE 3-3: INITIALIZATION CONDITIONS FOR ALL REGISTERS

Register	Applicable Devices		Power-on Reset, Brown-out Reset	MCLR Resets WDT Reset RESET Instruction Stack Resets	Wake-up via WDT or Interrupt
TOSU	PIC18F6X2X	PIC18F8X2X	---0 0000	---0 0000	---0 uuuu ⁽³⁾
TOSH	PIC18F6X2X	PIC18F8X2X	0000 0000	0000 0000	uuuu uuuu ⁽³⁾
TOSL	PIC18F6X2X	PIC18F8X2X	0000 0000	0000 0000	uuuu uuuu ⁽³⁾
STKPTR	PIC18F6X2X	PIC18F8X2X	00-0 0000	uu-0 0000	uu-u uuuu ⁽³⁾
PCLATU	PIC18F6X2X	PIC18F8X2X	---0 0000	---0 0000	---u uuuu
PCLATH	PIC18F6X2X	PIC18F8X2X	0000 0000	0000 0000	uuuu uuuu
PCL	PIC18F6X2X	PIC18F8X2X	0000 0000	0000 0000	PC + 2 ⁽²⁾
TBLPTRU	PIC18F6X2X	PIC18F8X2X	--00 0000	--00 0000	--uu uuuu
TBLPTRH	PIC18F6X2X	PIC18F8X2X	0000 0000	0000 0000	uuuu uuuu
TBLPTRL	PIC18F6X2X	PIC18F8X2X	0000 0000	0000 0000	uuuu uuuu
TABLAT	PIC18F6X2X	PIC18F8X2X	0000 0000	0000 0000	uuuu uuuu
PRODH	PIC18F6X2X	PIC18F8X2X	xxxx xxxx	uuuu uuuu	uuuu uuuu
PRODL	PIC18F6X2X	PIC18F8X2X	xxxx xxxx	uuuu uuuu	uuuu uuuu
INTCON	PIC18F6X2X	PIC18F8X2X	0000 000x	0000 000u	uuuu uuuu ⁽¹⁾
INTCON2	PIC18F6X2X	PIC18F8X2X	1111 1111	1111 1111	uuuu uuuu ⁽¹⁾
INTCON3	PIC18F6X2X	PIC18F8X2X	1100 0000	1100 0000	uuuu uuuu ⁽¹⁾
INDF0	PIC18F6X2X	PIC18F8X2X	N/A	N/A	N/A
POSTINC0	PIC18F6X2X	PIC18F8X2X	N/A	N/A	N/A
POSTDEC0	PIC18F6X2X	PIC18F8X2X	N/A	N/A	N/A
PREINC0	PIC18F6X2X	PIC18F8X2X	N/A	N/A	N/A
PLUSW0	PIC18F6X2X	PIC18F8X2X	N/A	N/A	N/A
FSR0H	PIC18F6X2X	PIC18F8X2X	---- 0000	---- 0000	---- uuuu
FSR0L	PIC18F6X2X	PIC18F8X2X	xxxx xxxx	uuuu uuuu	uuuu uuuu
WREG	PIC18F6X2X	PIC18F8X2X	xxxx xxxx	uuuu uuuu	uuuu uuuu
INDF1	PIC18F6X2X	PIC18F8X2X	N/A	N/A	N/A
POSTINC1	PIC18F6X2X	PIC18F8X2X	N/A	N/A	N/A
POSTDEC1	PIC18F6X2X	PIC18F8X2X	N/A	N/A	N/A
PREINC1	PIC18F6X2X	PIC18F8X2X	N/A	N/A	N/A
PLUSW1	PIC18F6X2X	PIC18F8X2X	N/A	N/A	N/A
FSR1H	PIC18F6X2X	PIC18F8X2X	---- 0000	---- 0000	---- uuuu

Legend: u = unchanged, x = unknown, - = unimplemented bit, read as '0', q = value depends on condition.
Shaded cells indicate conditions do not apply for the designated device.

- Note 1:** One or more bits in the INTCONx or PIRx registers will be affected (to cause wake-up).
- 2:** When the wake-up is due to an interrupt and the GIEL or GIEH bit is set, the PC is loaded with the interrupt vector (0008h or 0018h).
- 3:** When the wake-up is due to an interrupt and the GIEL or GIEH bit is set, the TOSU, TOSH and TOSL are updated with the current value of the PC. The STKPTR is modified to point to the next location in the hardware stack.
- 4:** See Table 3-2 for Reset value for specific condition.
- 5:** Bit 6 of PORTA, LATA and TRISA are enabled in ECIO and RCIO Oscillator modes only. In all other oscillator modes, they are disabled and read '0'.
- 6:** Bit 6 of PORTA, LATA and TRISA are not available on all devices. When unimplemented, they are read '0'.
- 7:** If MCLR function is disabled, PORTG<5> is a read-only bit.
- 8:** Enabled only in Microcontroller mode for PIC18F8525/8621 devices.
- 9:** The MEMCON register is unimplemented and reads all '0's when the device is in Microcontroller mode.

PIC18F6525/6621/8525/8621

TABLE 3-3: INITIALIZATION CONDITIONS FOR ALL REGISTERS (CONTINUED)

Register	Applicable Devices		Power-on Reset, Brown-out Reset	MCLR Resets WDT Reset RESET Instruction Stack Resets	Wake-up via WDT or Interrupt
FSR1L	PIC18F6X2X	PIC18F8X2X	xxxx xxxx	uuuu uuuu	uuuu uuuu
BSR	PIC18F6X2X	PIC18F8X2X	---- 0000	---- 0000	---- uuuu
INDF2	PIC18F6X2X	PIC18F8X2X	N/A	N/A	N/A
POSTINC2	PIC18F6X2X	PIC18F8X2X	N/A	N/A	N/A
POSTDEC2	PIC18F6X2X	PIC18F8X2X	N/A	N/A	N/A
PREINC2	PIC18F6X2X	PIC18F8X2X	N/A	N/A	N/A
PLUSW2	PIC18F6X2X	PIC18F8X2X	N/A	N/A	N/A
FSR2H	PIC18F6X2X	PIC18F8X2X	---- 0000	---- 0000	---- uuuu
FSR2L	PIC18F6X2X	PIC18F8X2X	xxxx xxxx	uuuu uuuu	uuuu uuuu
STATUS	PIC18F6X2X	PIC18F8X2X	---x xxxx	---u uuuu	---u uuuu
TMR0H	PIC18F6X2X	PIC18F8X2X	0000 0000	uuuu uuuu	uuuu uuuu
TMR0L	PIC18F6X2X	PIC18F8X2X	xxxx xxxx	uuuu uuuu	uuuu uuuu
T0CON	PIC18F6X2X	PIC18F8X2X	1111 1111	1111 1111	uuuu uuuu
OSCCON	PIC18F6X2X	PIC18F8X2X	---- 0000	---- 0000	---- uuuu
LVDCON	PIC18F6X2X	PIC18F8X2X	--00 0101	--00 0101	--uu uuuu
WDTCON	PIC18F6X2X	PIC18F8X2X	---- ---0	---- ---0	---- ---u
RCON ⁽⁴⁾	PIC18F6X2X	PIC18F8X2X	0--1 11qq	0--1 qquu	u--1 qquu
TMR1H	PIC18F6X2X	PIC18F8X2X	xxxx xxxx	uuuu uuuu	uuuu uuuu
TMR1L	PIC18F6X2X	PIC18F8X2X	xxxx xxxx	uuuu uuuu	uuuu uuuu
T1CON	PIC18F6X2X	PIC18F8X2X	0-00 0000	u-uu uuuu	u-uu uuuu
TMR2	PIC18F6X2X	PIC18F8X2X	0000 0000	0000 0000	uuuu uuuu
PR2	PIC18F6X2X	PIC18F8X2X	1111 1111	1111 1111	uuuu uuuu
T2CON	PIC18F6X2X	PIC18F8X2X	-000 0000	-000 0000	-uuu uuuu
SSPBUF	PIC18F6X2X	PIC18F8X2X	xxxx xxxx	uuuu uuuu	uuuu uuuu
SSPADD	PIC18F6X2X	PIC18F8X2X	0000 0000	0000 0000	uuuu uuuu
SSPSTAT	PIC18F6X2X	PIC18F8X2X	0000 0000	0000 0000	uuuu uuuu
SSPCON1	PIC18F6X2X	PIC18F8X2X	0000 0000	0000 0000	uuuu uuuu
SSPCON2	PIC18F6X2X	PIC18F8X2X	0000 0000	0000 0000	uuuu uuuu
ADRESH	PIC18F6X2X	PIC18F8X2X	xxxx xxxx	uuuu uuuu	uuuu uuuu
ADRESL	PIC18F6X2X	PIC18F8X2X	xxxx xxxx	uuuu uuuu	uuuu uuuu

Legend: u = unchanged, x = unknown, - = unimplemented bit, read as '0', q = value depends on condition.
Shaded cells indicate conditions do not apply for the designated device.

- Note 1:** One or more bits in the INTCONx or PIRx registers will be affected (to cause wake-up).
- 2:** When the wake-up is due to an interrupt and the GIEL or GIEH bit is set, the PC is loaded with the interrupt vector (0008h or 0018h).
 - 3:** When the wake-up is due to an interrupt and the GIEL or GIEH bit is set, the TOSU, TOSH and TOSL are updated with the current value of the PC. The STKPTR is modified to point to the next location in the hardware stack.
 - 4:** See Table 3-2 for Reset value for specific condition.
 - 5:** Bit 6 of PORTA, LATA and TRISA are enabled in ECIO and RCIO Oscillator modes only. In all other oscillator modes, they are disabled and read '0'.
 - 6:** Bit 6 of PORTA, LATA and TRISA are not available on all devices. When unimplemented, they are read '0'.
 - 7:** If MCLR function is disabled, PORTG<5> is a read-only bit.
 - 8:** Enabled only in Microcontroller mode for PIC18F8525/8621 devices.
 - 9:** The MEMCON register is unimplemented and reads all '0's when the device is in Microcontroller mode.

PIC18F6525/6621/8525/8621

TABLE 3-3: INITIALIZATION CONDITIONS FOR ALL REGISTERS (CONTINUED)

Register	Applicable Devices		Power-on Reset, Brown-out Reset	MCLR Resets WDT Reset RESET Instruction Stack Resets	Wake-up via WDT or Interrupt
ADCON0	PIC18F6X2X	PIC18F8X2X	--00 0000	--00 0000	--uu uuuu
ADCON1	PIC18F6X2X	PIC18F8X2X	--00 0000	--00 0000	--uu uuuu
ADCON2	PIC18F6X2X	PIC18F8X2X	0-00 0000	0-00 0000	u-uu uuuu
CCPR1H	PIC18F6X2X	PIC18F8X2X	xxxx xxxx	uuuu uuuu	uuuu uuuu
CCPR1L	PIC18F6X2X	PIC18F8X2X	xxxx xxxx	uuuu uuuu	uuuu uuuu
CCP1CON	PIC18F6X2X	PIC18F8X2X	0000 0000	0000 0000	uuuu uuuu
CCPR2H	PIC18F6X2X	PIC18F8X2X	xxxx xxxx	uuuu uuuu	uuuu uuuu
CCPR2L	PIC18F6X2X	PIC18F8X2X	xxxx xxxx	uuuu uuuu	uuuu uuuu
CCP2CON	PIC18F6X2X	PIC18F8X2X	--00 0000	--00 0000	--uu uuuu
CCPR3H	PIC18F6X2X	PIC18F8X2X	xxxx xxxx	uuuu uuuu	uuuu uuuu
CCPR3L	PIC18F6X2X	PIC18F8X2X	xxxx xxxx	uuuu uuuu	uuuu uuuu
CCP3CON	PIC18F6X2X	PIC18F8X2X	0000 0000	0000 0000	uuuu uuuu
ECCP1AS	PIC18F6X2X	PIC18F8X2X	0000 0000	0000 0000	uuuu uuuu
CVRCON	PIC18F6X2X	PIC18F8X2X	0000 0000	0000 0000	uuuu uuuu
CMCON	PIC18F6X2X	PIC18F8X2X	0000 0000	0000 0000	uuuu uuuu
TMR3H	PIC18F6X2X	PIC18F8X2X	xxxx xxxx	uuuu uuuu	uuuu uuuu
TMR3L	PIC18F6X2X	PIC18F8X2X	xxxx xxxx	uuuu uuuu	uuuu uuuu
T3CON	PIC18F6X2X	PIC18F8X2X	0000 0000	uuuu uuuu	uuuu uuuu
PSPCON ⁽⁸⁾	PIC18F6X2X	PIC18F8X2X	0000 ----	0000 ----	uuuu ----
SPBRG1	PIC18F6X2X	PIC18F8X2X	0000 0000	0000 0000	uuuu uuuu
RCREG1	PIC18F6X2X	PIC18F8X2X	0000 0000	0000 0000	uuuu uuuu
TXREG1	PIC18F6X2X	PIC18F8X2X	0000 0000	0000 0000	uuuu uuuu
TXSTA1	PIC18F6X2X	PIC18F8X2X	0000 0010	0000 0010	uuuu uuuu
RCSTA1	PIC18F6X2X	PIC18F8X2X	0000 000x	0000 000x	uuuu uuuu
EEADRH	PIC18F6X2X	PIC18F8X2X	---- --00	---- --00	---- --uu
EEADR	PIC18F6X2X	PIC18F8X2X	0000 0000	0000 0000	uuuu uuuu
EEDATA	PIC18F6X2X	PIC18F8X2X	0000 0000	0000 0000	uuuu uuuu
EECON2	PIC18F6X2X	PIC18F8X2X	---- ----	---- ----	---- ----
EECON1	PIC18F6X2X	PIC18F8X2X	xx-0 x000	uu-0 u000	uu-u u000

Legend: u = unchanged, x = unknown, - = unimplemented bit, read as '0', q = value depends on condition.
Shaded cells indicate conditions do not apply for the designated device.

- Note 1:** One or more bits in the INTCONx or PIRx registers will be affected (to cause wake-up).
2: When the wake-up is due to an interrupt and the GIEL or GIEH bit is set, the PC is loaded with the interrupt vector (0008h or 0018h).
3: When the wake-up is due to an interrupt and the GIEL or GIEH bit is set, the TOSU, TOSH and TOSL are updated with the current value of the PC. The STKPTR is modified to point to the next location in the hardware stack.
4: See Table 3-2 for Reset value for specific condition.
5: Bit 6 of PORTA, LATA and TRISA are enabled in ECIO and RCIO Oscillator modes only. In all other oscillator modes, they are disabled and read '0'.
6: Bit 6 of PORTA, LATA and TRISA are not available on all devices. When unimplemented, they are read '0'.
7: If MCLR function is disabled, PORTG<5> is a read-only bit.
8: Enabled only in Microcontroller mode for PIC18F8525/8621 devices.
9: The MEMCON register is unimplemented and reads all '0's when the device is in Microcontroller mode.

PIC18F6525/6621/8525/8621

TABLE 3-3: INITIALIZATION CONDITIONS FOR ALL REGISTERS (CONTINUED)

Register	Applicable Devices		Power-on Reset, Brown-out Reset	MCLR Resets WDT Reset RESET Instruction Stack Resets	Wake-up via WDT or Interrupt
IPR3	PIC18F6X2X	PIC18F8X2X	--11 1111	--11 1111	--uu uuuu
PIR3	PIC18F6X2X	PIC18F8X2X	--00 0000	--00 0000	--uu uuuu
PIE3	PIC18F6X2X	PIC18F8X2X	--00 0000	--00 0000	--uu uuuu
IPR2	PIC18F6X2X	PIC18F8X2X	-1-1 1111	-1-1 1111	-u-u uuuu
PIR2	PIC18F6X2X	PIC18F8X2X	-0-0 0000	-0-0 0000	-u-u uuuu ⁽¹⁾
PIE2	PIC18F6X2X	PIC18F8X2X	-0-0 0000	-0-0 0000	-u-u uuuu
IPR1	PIC18F6X2X	PIC18F8X2X	1111 1111	1111 1111	uuuu uuuu
PIR1	PIC18F6X2X	PIC18F8X2X	0000 0000	0000 0000	uuuu uuuu ⁽¹⁾
PIE1	PIC18F6X2X	PIC18F8X2X	0000 0000	0000 0000	uuuu uuuu
MEMCON ⁽⁹⁾	PIC18F6X2X	PIC18F8X2X	0-00 --00	0-00 --00	u-uu --uu
TRISJ	PIC18F6X2X	PIC18F8X2X	1111 1111	1111 1111	uuuu uuuu
TRISH	PIC18F6X2X	PIC18F8X2X	1111 1111	1111 1111	uuuu uuuu
TRISG	PIC18F6X2X	PIC18F8X2X	---1 1111	---1 1111	---u uuuu
TRISF	PIC18F6X2X	PIC18F8X2X	1111 1111	1111 1111	uuuu uuuu
TRISE	PIC18F6X2X	PIC18F8X2X	1111 1111	1111 1111	uuuu uuuu
TRISD	PIC18F6X2X	PIC18F8X2X	1111 1111	1111 1111	uuuu uuuu
TRISC	PIC18F6X2X	PIC18F8X2X	1111 1111	1111 1111	uuuu uuuu
TRISB	PIC18F6X2X	PIC18F8X2X	1111 1111	1111 1111	uuuu uuuu
TRISA ^(5,6)	PIC18F6X2X	PIC18F8X2X	-111 1111 ⁽⁵⁾	-111 1111 ⁽⁵⁾	-uuu uuuu ⁽⁵⁾
LATJ	PIC18F6X2X	PIC18F8X2X	xxxx xxxx	uuuu uuuu	uuuu uuuu
LATH	PIC18F6X2X	PIC18F8X2X	xxxx xxxx	uuuu uuuu	uuuu uuuu
LATG	PIC18F6X2X	PIC18F8X2X	---x xxxx	---u uuuu	---u uuuu
LATF	PIC18F6X2X	PIC18F8X2X	xxxx xxxx	uuuu uuuu	uuuu uuuu
LATE	PIC18F6X2X	PIC18F8X2X	xxxx xxxx	uuuu uuuu	uuuu uuuu
LATD	PIC18F6X2X	PIC18F8X2X	xxxx xxxx	uuuu uuuu	uuuu uuuu
LATC	PIC18F6X2X	PIC18F8X2X	xxxx xxxx	uuuu uuuu	uuuu uuuu
LATB	PIC18F6X2X	PIC18F8X2X	xxxx xxxx	uuuu uuuu	uuuu uuuu
LATA ^(5,6)	PIC18F6X2X	PIC18F8X2X	-xxx xxxx ⁽⁵⁾	-uuu uuuu ⁽⁵⁾	-uuu uuuu ⁽⁵⁾
PORTJ	PIC18F6X2X	PIC18F8X2X	xxxx xxxx	uuuu uuuu	uuuu uuuu
PORTH	PIC18F6X2X	PIC18F8X2X	0000 xxxx	0000 uuuu	uuuu uuuu

Legend: u = unchanged, x = unknown, - = unimplemented bit, read as '0', q = value depends on condition.
Shaded cells indicate conditions do not apply for the designated device.

- Note 1:** One or more bits in the INTCONx or PIRx registers will be affected (to cause wake-up).
- 2:** When the wake-up is due to an interrupt and the GIEL or GIEH bit is set, the PC is loaded with the interrupt vector (0008h or 0018h).
- 3:** When the wake-up is due to an interrupt and the GIEL or GIEH bit is set, the TOSU, TOSH and TOSL are updated with the current value of the PC. The STKPTR is modified to point to the next location in the hardware stack.
- 4:** See Table 3-2 for Reset value for specific condition.
- 5:** Bit 6 of PORTA, LATA and TRISA are enabled in ECIO and RCIO Oscillator modes only. In all other oscillator modes, they are disabled and read '0'.
- 6:** Bit 6 of PORTA, LATA and TRISA are not available on all devices. When unimplemented, they are read '0'.
- 7:** If MCLR function is disabled, PORTG<5> is a read-only bit.
- 8:** Enabled only in Microcontroller mode for PIC18F8525/8621 devices.
- 9:** The MEMCON register is unimplemented and reads all '0's when the device is in Microcontroller mode.

PIC18F6525/6621/8525/8621

TABLE 3-3: INITIALIZATION CONDITIONS FOR ALL REGISTERS (CONTINUED)

Register	Applicable Devices		Power-on Reset, Brown-out Reset	MCLR Resets WDT Reset RESET Instruction Stack Resets	Wake-up via WDT or Interrupt
PORTG ⁽⁷⁾	PIC18F6X2X	PIC18F8X2X	--xx xxxx	--uu uuuu	--uu uuuu
PORTF	PIC18F6X2X	PIC18F8X2X	x000 0000	u000 0000	uuuu uuuu
PORTE	PIC18F6X2X	PIC18F8X2X	xxxx xxxx	uuuu uuuu	uuuu uuuu
PORTD	PIC18F6X2X	PIC18F8X2X	xxxx xxxx	uuuu uuuu	uuuu uuuu
PORTC	PIC18F6X2X	PIC18F8X2X	xxxx xxxx	uuuu uuuu	uuuu uuuu
PORTB	PIC18F6X2X	PIC18F8X2X	xxxx xxxx	uuuu uuuu	uuuu uuuu
PORTA ^(5,6)	PIC18F6X2X	PIC18F8X2X	-x0x 0000 ⁽⁵⁾	-u0u 0000 ⁽⁵⁾	-uuu uuuu ⁽⁵⁾
SPBRGH1	PIC18F6X2X	PIC18F8X2X	0000 0000	0000 0000	uuuu uuuu
BAUDCON1	PIC18F6X2X	PIC18F8X2X	-1-0 0-00	-1-0 0-00	-u-u u-uu
SPBRGH2	PIC18F6X2X	PIC18F8X2X	0000 0000	0000 0000	uuuu uuuu
BAUDCON2	PIC18F6X2X	PIC18F8X2X	-1-0 0-00	-1-0 0-00	-u-1 u-uu
ECCP1DEL	PIC18F6X2X	PIC18F8X2X	0000 0000	0000 0000	uuuu uuuu
TMR4	PIC18F6X2X	PIC18F8X2X	0000 0000	0000 0000	uuuu uuuu
PR4	PIC18F6X2X	PIC18F8X2X	1111 1111	1111 1111	uuuu uuuu
T4CON	PIC18F6X2X	PIC18F8X2X	-000 0000	-000 0000	-uuu uuuu
CCPR4H	PIC18F6X2X	PIC18F8X2X	xxxx xxxx	xxxx xxxx	uuuu uuuu
CCPR4L	PIC18F6X2X	PIC18F8X2X	xxxx xxxx	xxxx xxxx	uuuu uuuu
CCP4CON	PIC18F6X2X	PIC18F8X2X	--00 0000	--00 0000	--uu uuuu
CCPR5H	PIC18F6X2X	PIC18F8X2X	xxxx xxxx	xxxx xxxx	uuuu uuuu
CCPR5L	PIC18F6X2X	PIC18F8X2X	xxxx xxxx	xxxx xxxx	uuuu uuuu
CCP5CON	PIC18F6X2X	PIC18F8X2X	--00 0000	--00 0000	--uu uuuu
SPBRG2	PIC18F6X2X	PIC18F8X2X	0000 0000	0000 0000	uuuu uuuu
RCREG2	PIC18F6X2X	PIC18F8X2X	0000 0000	0000 0000	uuuu uuuu
TXREG2	PIC18F6X2X	PIC18F8X2X	0000 0000	0000 0000	uuuu uuuu
TXSTA2	PIC18F6X2X	PIC18F8X2X	0000 0010	0000 0010	uuuu uuuu
RCSTA2	PIC18F6X2X	PIC18F8X2X	0000 000x	0000 000x	uuuu uuuu
ECCP3AS	PIC18F6X2X	PIC18F8X2X	0000 0000	0000 0000	uuuu uuuu
ECCP3DEL	PIC18F6X2X	PIC18F8X2X	0000 0000	0000 0000	uuuu uuuu
ECCP2AS	PIC18F6X2X	PIC18F8X2X	0000 0000	0000 0000	uuuu uuuu
ECCP2DEL	PIC18F6X2X	PIC18F8X2X	0000 0000	0000 0000	uuuu uuuu

Legend: u = unchanged, x = unknown, - = unimplemented bit, read as '0', q = value depends on condition.
Shaded cells indicate conditions do not apply for the designated device.

- Note 1:** One or more bits in the INTCONx or PIRx registers will be affected (to cause wake-up).
Note 2: When the wake-up is due to an interrupt and the GIEL or GIEH bit is set, the PC is loaded with the interrupt vector (0008h or 0018h).
Note 3: When the wake-up is due to an interrupt and the GIEL or GIEH bit is set, the TOSU, TOSH and TOSL are updated with the current value of the PC. The STKPTR is modified to point to the next location in the hardware stack.
Note 4: See Table 3-2 for Reset value for specific condition.
Note 5: Bit 6 of PORTA, LATA and TRISA are enabled in ECIO and RCIO Oscillator modes only. In all other oscillator modes, they are disabled and read '0'.
Note 6: Bit 6 of PORTA, LATA and TRISA are not available on all devices. When unimplemented, they are read '0'.
Note 7: If MCLR function is disabled, PORTG<5> is a read-only bit.
Note 8: Enabled only in Microcontroller mode for PIC18F8525/8621 devices.
Note 9: The MEMCON register is unimplemented and reads all '0's when the device is in Microcontroller mode.

PIC18F6525/6621/8525/8621

FIGURE 3-3: TIME-OUT SEQUENCE ON POWER-UP ($\overline{\text{MCLR}}$ TIED TO V_{DD} VIA 1 k Ω RESISTOR)

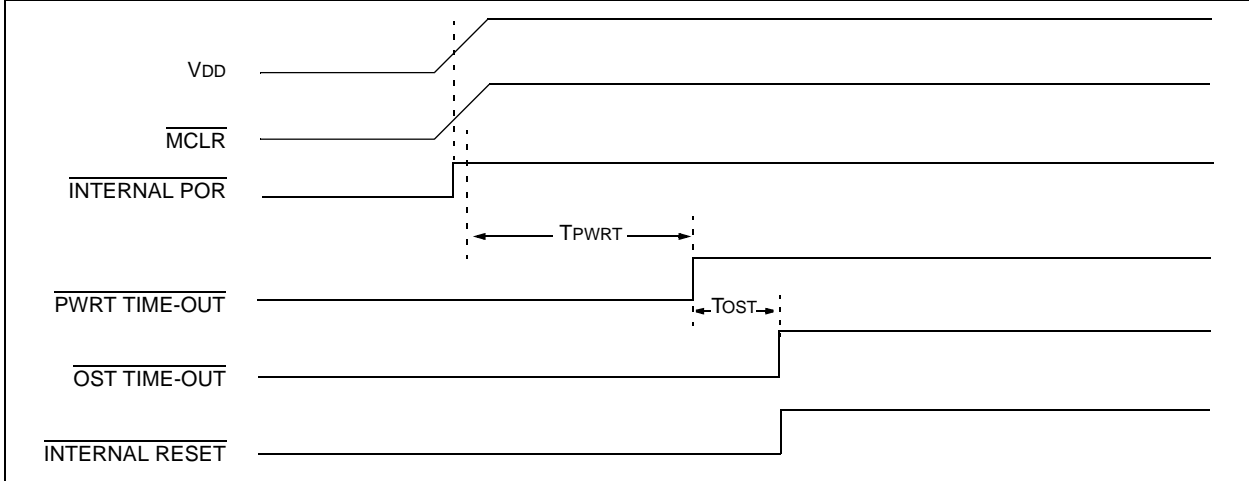

FIGURE 3-4: TIME-OUT SEQUENCE ON POWER-UP ($\overline{\text{MCLR}}$ NOT TIED TO V_{DD}): CASE 1

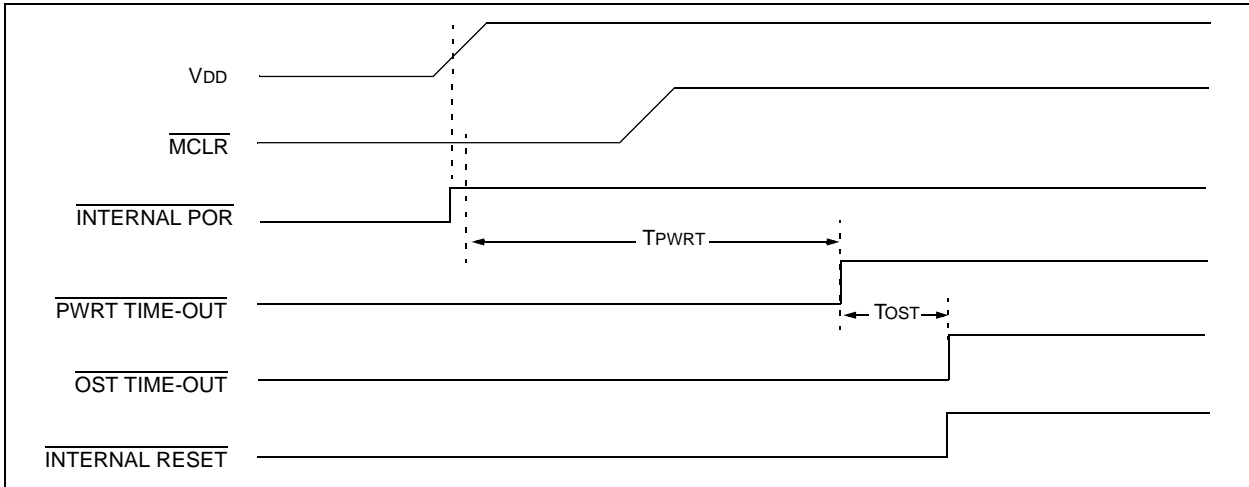
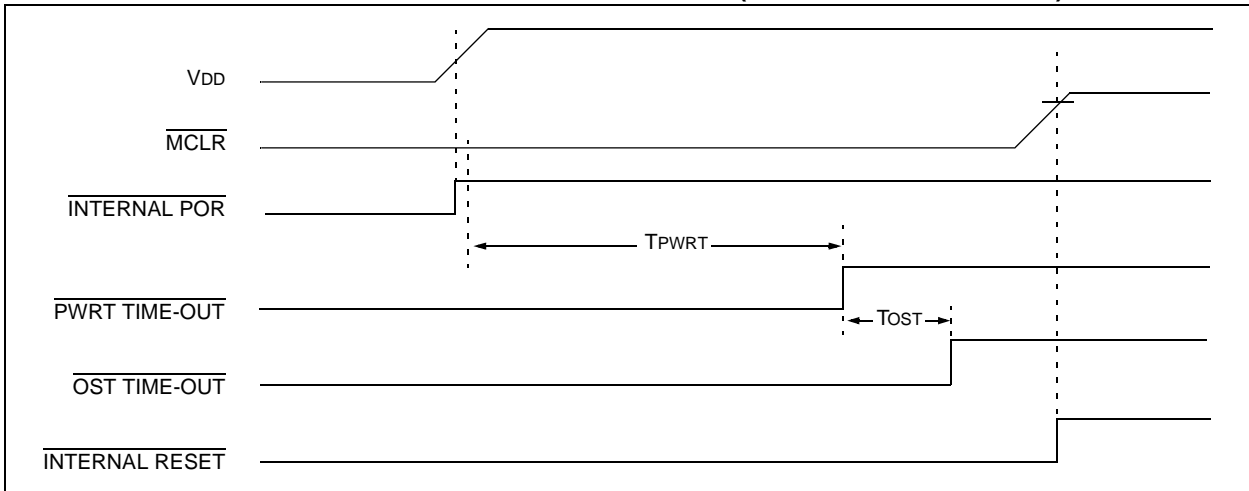

FIGURE 3-5: TIME-OUT SEQUENCE ON POWER-UP ($\overline{\text{MCLR}}$ NOT TIED TO V_{DD}): CASE 2



PIC18F6525/6621/8525/8621

FIGURE 3-6: SLOW RISE TIME ($\overline{\text{MCLR}}$ TIED TO V_{DD} VIA 1 k Ω RESISTOR)

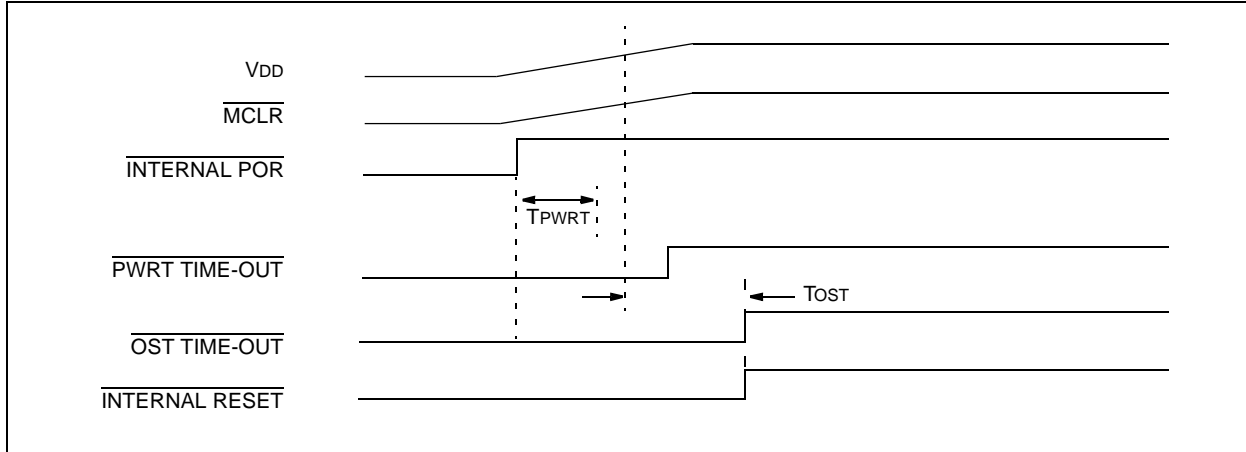
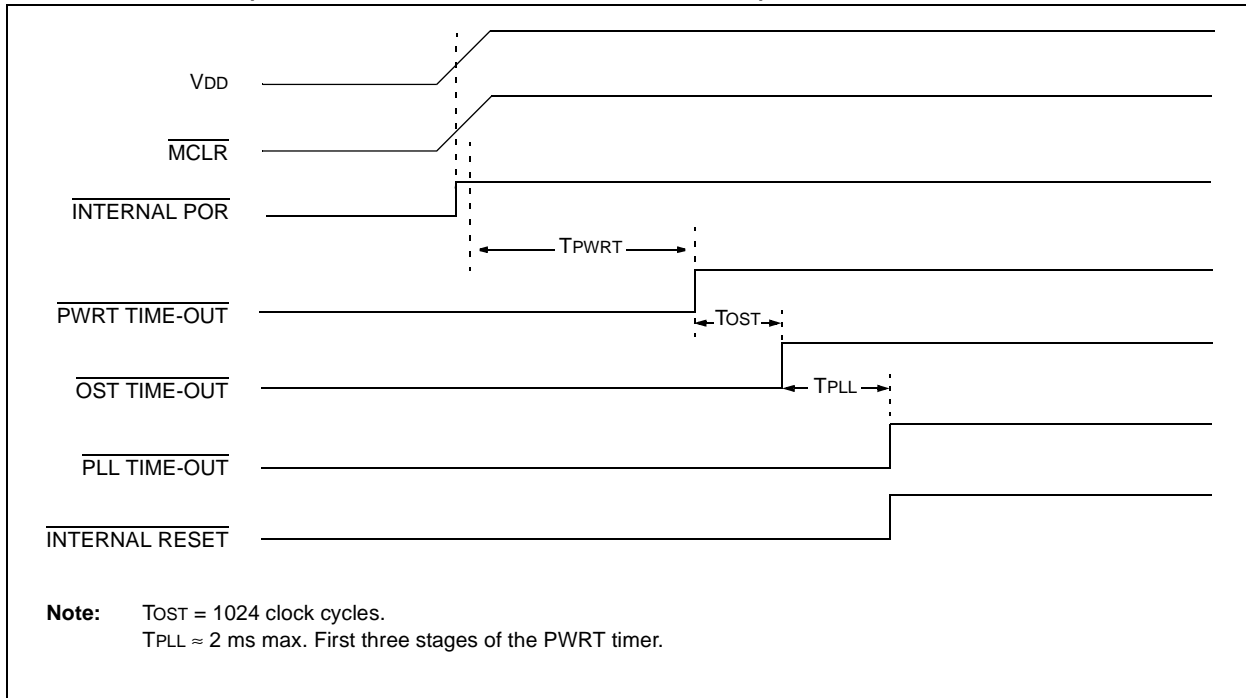

FIGURE 3-7: TIME-OUT SEQUENCE ON POR W/PLL ENABLED ($\overline{\text{MCLR}}$ TIED TO V_{DD} VIA 1 k Ω RESISTOR)



4.0 MEMORY ORGANIZATION

There are three memory blocks in PIC18F6525/6621/8525/8621 devices. They are:

- Program Memory
- Data RAM
- Data EEPROM

Data and program memory use separate busses which allow for concurrent access of these blocks. Additional detailed information for Flash program memory and data EEPROM is provided in **Section 5.0 “Flash Program Memory”** and **Section 7.0 “Data EEPROM Memory”**, respectively.

In addition to on-chip Flash, the PIC18F8525/8621 devices are also capable of accessing external program memory through an external memory bus. Depending on the selected operating mode (discussed in **Section 4.1.1 “PIC18F6525/6621/8525/8621 Program Memory Modes”**), the controllers may access either internal or external program memory exclusively, or both internal and external memory in selected blocks. Additional information on the external memory interface is provided in **Section 6.0 “External Memory Interface”**.

4.1 Program Memory Organization

A 21-bit program counter is capable of addressing the 2-Mbyte program memory space. Accessing a location between the physically implemented memory and the 2-Mbyte address will cause a read of all '0's (a *NOP* instruction).

The PIC18F6525 and PIC18F8525 each have 48 Kbytes of on-chip Flash memory, while the PIC18F6621 and PIC18F8621 have 64 Kbytes of Flash. This means that PIC18FX525 devices can store internally up to 24,576 single-word instructions and PIC18FX621 devices can store up to 32,768 single-word instructions.

The Reset vector address is at 0000h and the interrupt vector addresses are at 0008h and 0018h.

Figure 4-1 shows the program memory map for PIC18FX525 devices, while Figure 4-2 shows the program memory map for PIC18FX621 devices.

4.1.1 PIC18F6525/6621/8525/8621 PROGRAM MEMORY MODES

PIC18F8525/8621 devices differ significantly from their PIC18 predecessors in their utilization of program memory. In addition to available on-chip Flash program memory, these controllers can also address up to 2 Mbytes of external program memory through the external memory interface. There are four distinct operating modes available to the controllers:

- Microprocessor (MP)
- Microprocessor with Boot Block (MPBB)
- Extended Microcontroller (EMC)
- Microcontroller (MC)

The Program Memory mode is determined by setting the two Least Significant bits of the CONFIG3L Configuration Byte register as shown in Register 4-1 (see **Section 24.1 “Configuration Bits”** for additional details on the device configuration bits).

The Program Memory modes operate as follows:

- The **Microprocessor Mode** permits access only to external program memory; the contents of the on-chip Flash memory are ignored. The 21-bit program counter permits access to a 2-Mbyte linear program memory space.
- The **Microprocessor with Boot Block Mode** accesses on-chip Flash memory from addresses 000000h to 0007FFh. Above this, external program memory is accessed all the way up to the 2-Mbyte limit. Program execution automatically switches between the two memories as required.
- The **Microcontroller Mode** accesses only on-chip Flash memory. Attempts to read above the physical limit of the on-chip Flash (BFFFh for the PIC18FX525, FFFFh for the PIC18FX621) causes a read of all '0's (a *NOP* instruction). The Microcontroller mode is also the only operating mode available to PIC18F6525/6621 devices.
- The **Extended Microcontroller Mode** allows access to both internal and external program memories as a single block. The device can access its entire on-chip Flash memory; above this, the device accesses external program memory up to the 2-Mbyte program space limit. As with Boot Block mode, execution automatically switches between the two memories as required.

In all modes, the microcontroller has complete access to data RAM and EEPROM.

Figure 4-3 compares the memory maps of the different program memory modes. The differences between on-chip and external memory access limitations are more fully explained in Table 4-1.

PIC18F6525/6621/8525/8621

FIGURE 4-1: INTERNAL PROGRAM MEMORY MAP AND STACK FOR PIC18FX525

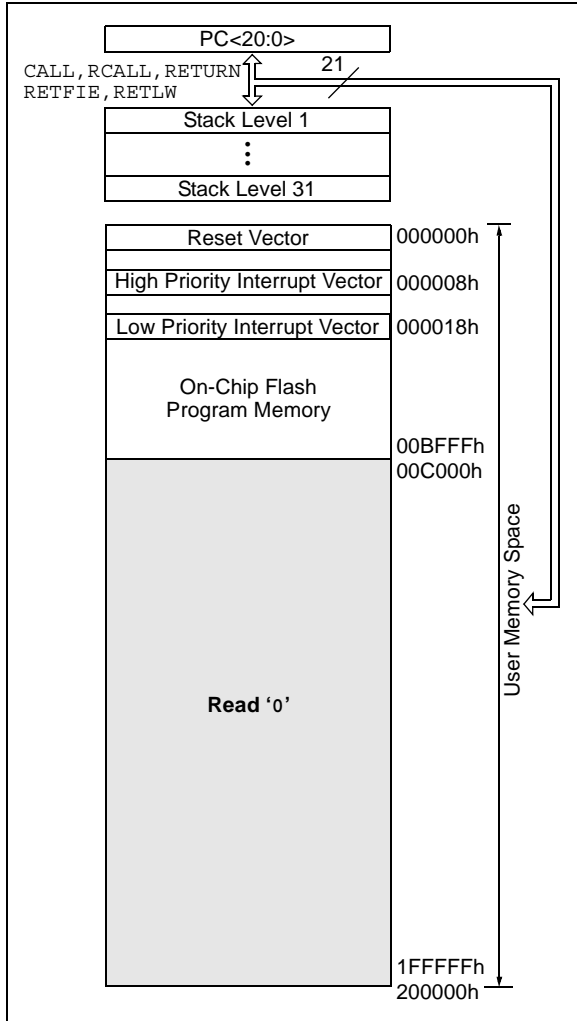

FIGURE 4-2: INTERNAL PROGRAM MEMORY MAP AND STACK FOR PIC18FX621

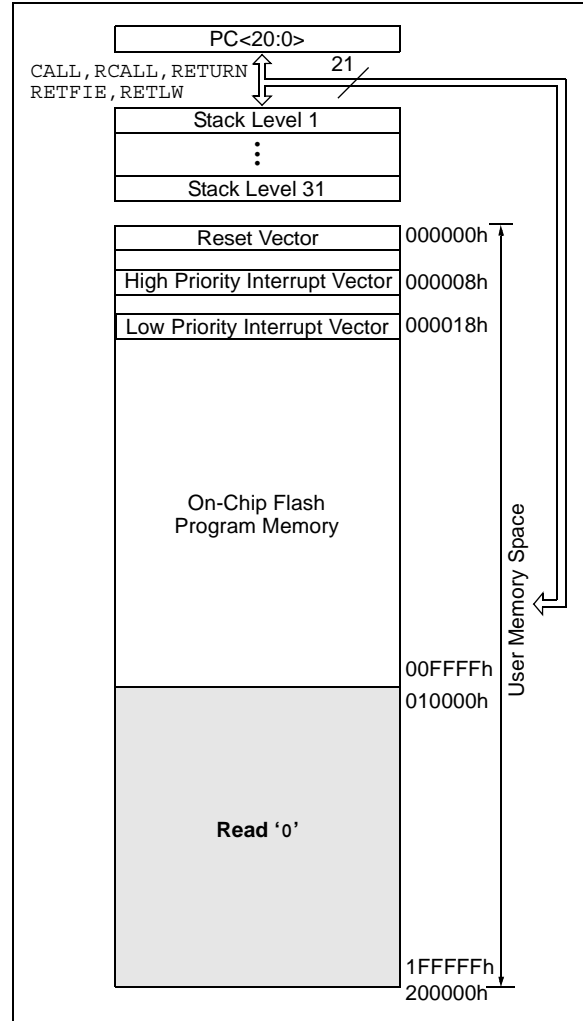

TABLE 4-1: MEMORY ACCESS FOR PIC18F8525/8621 PROGRAM MEMORY MODES

Operating Mode	Internal Program Memory			External Program Memory		
	Execution From	Table Read From	Table Write To	Execution From	Table Read From	Table Write To
Microprocessor	No Access	No Access	No Access	Yes	Yes	Yes
Microprocessor w/Boot Block	Yes	Yes	Yes	Yes	Yes	Yes
Microcontroller	Yes	Yes	Yes	No Access	No Access	No Access
Extended Microcontroller	Yes	Yes	Yes	Yes	Yes	Yes

PIC18F6525/6621/8525/8621

REGISTER 4-1: CONFIG3L: CONFIGURATION REGISTER 3 LOW

R/P-1	U-0	U-0	U-0	U-0	U-0	R/P-1	R/P-1
WAIT	—	—	—	—	—	PM1	PM0
bit 7						bit 0	

- bit 7 **WAIT:** External Bus Data Wait Enable bit
 1 = Wait selections unavailable, device will not wait
 0 = Wait programmed by WAIT1 and WAIT0 bits of MEMCOM register (MEMCOM<5:4>)
- bit 6-2 **Unimplemented:** Read as '0'
- bit 1-0 **PM1:PM0:** Processor Data Memory Mode Select bits
 11 = Microcontroller mode
 10 = Microprocessor mode⁽¹⁾
 01 = Microcontroller with Boot Block mode⁽¹⁾
 00 = Extended Microcontroller mode⁽¹⁾

Note 1: This mode is available only on PIC18F8525/8621 devices.

Legend:

R = Readable bit P = Programmable bit U = Unimplemented bit, read as '0'
 -n = Value after erase '1' = Bit is set '0' = Bit is cleared x = Bit is unknown

FIGURE 4-3: MEMORY MAPS FOR PIC18F6525/6621/8525/8621 PROGRAM MEMORY MODES

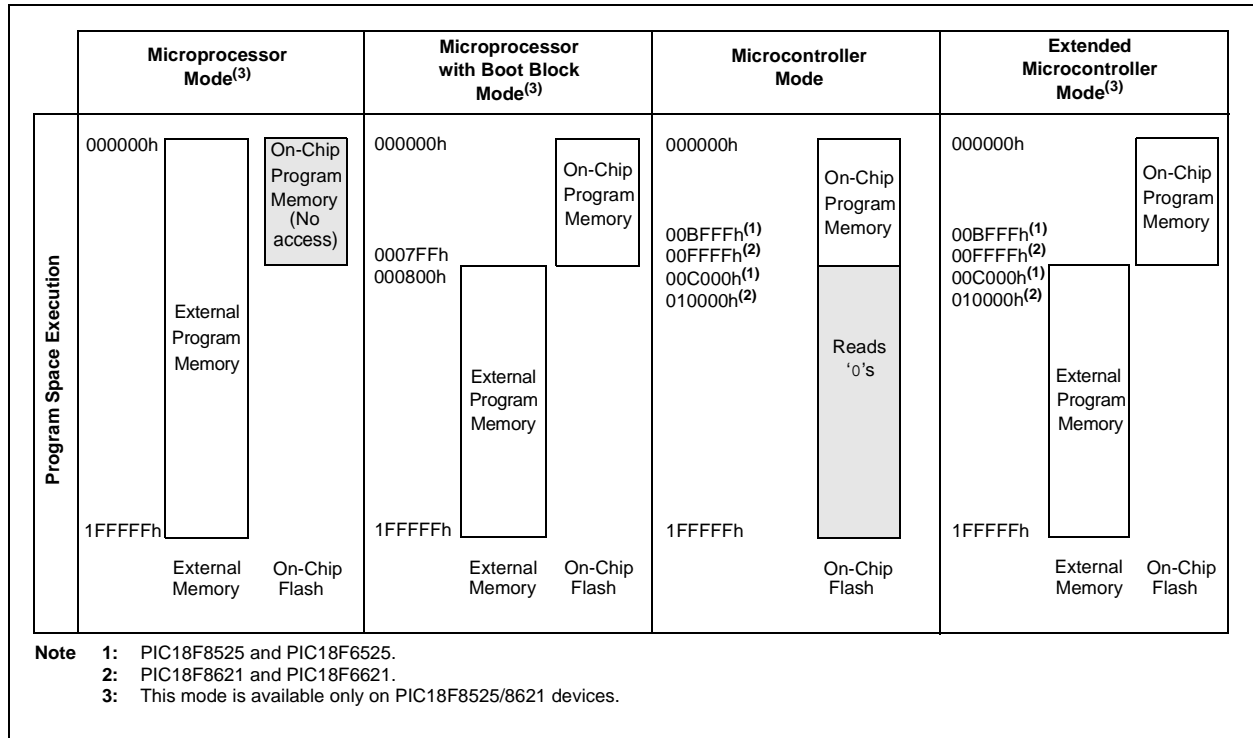

PIC18F6525/6621/8525/8621

4.2 Return Address Stack

The return address stack allows any combination of up to 31 program calls and interrupts to occur. The PC (Program Counter) is pushed onto the stack when a `CALL` or `RCALL` instruction is executed, or an interrupt is Acknowledged. The PC value is pulled off the stack on a `RETURN`, `RETLW` or a `RETFIE` instruction. `PCLATU` and `PCLATH` are not affected by any of the `RETURN` or `CALL` instructions.

The stack operates as a 31-word by 21-bit RAM and a 5-bit Stack Pointer, with the Stack Pointer initialized to `00000b` after all Resets. There is no RAM associated with Stack Pointer `00000b`. This is only a Reset value. During a `CALL` type instruction causing a push onto the stack, the Stack Pointer is first incremented and the RAM location pointed to by the Stack Pointer is written with the contents of the PC. During a `RETURN` type instruction causing a pop from the stack, the contents of the RAM location pointed to by the `STKPTR` register are transferred to the PC and then the Stack Pointer is decremented.

The stack space is not part of either program or data space. The Stack Pointer is readable and writable and the address on the top of the stack is readable and writable through SFR registers. Data can also be pushed to, or popped from the stack using the Top-of-Stack SFRs. Status bits indicate if the Stack Pointer is at or beyond the 31 levels provided.

4.2.1 TOP-OF-STACK ACCESS

The top of the stack is readable and writable. Three register locations, `TOSU`, `TOSH` and `TOSL`, hold the contents of the stack location pointed to by the `STKPTR` register. This allows users to implement a software stack if necessary. After a `CALL`, `RCALL` or interrupt, the software can read the pushed value by reading the `TOSU`, `TOSH` and `TOSL` registers. These values can be placed on a user defined software stack. At return time, the software can replace the `TOSU`, `TOSH` and `TOSL` and do a return.

The user must disable the global interrupt enable bits during this time to prevent inadvertent stack operations.

4.2.2 RETURN STACK POINTER (STKPTR)

The `STKPTR` register contains the Stack Pointer value, the `STKFUL` (Stack Full) status bit and the `STKUNF` (Stack Underflow) status bits. Register 4-2 shows the `STKPTR` register. The value of the Stack Pointer can be 0 through 31. The Stack Pointer increments when values are pushed onto the stack and decrements when values are popped off the stack. At Reset, the Stack Pointer value will be '0'. The user may read and write the Stack Pointer value. This feature can be used by a real-time operating system for return stack maintenance.

After the PC is pushed onto the stack 31 times (without popping any values off the stack), the `STKFUL` bit is set. The `STKFUL` bit can only be cleared in software or by a POR.

The action that takes place when the stack becomes full depends on the state of the `STVREN` (Stack Overflow Reset Enable) configuration bit. Refer to **Section 25.0 "Instruction Set Summary"** for a description of the device configuration bits. If `STVREN` is set (default), the 31st push will push the `(PC + 2)` value onto the stack, set the `STKFUL` bit and reset the device. The `STKFUL` bit will remain set and the Stack Pointer will be set to '0'.

If `STVREN` is cleared, the `STKFUL` bit will be set on the 31st push and the Stack Pointer will increment to 31. Any additional pushes will not overwrite the 31st push and `STKPTR` will remain at 31.

When the stack has been popped enough times to unload the stack, the next pop will return a value of zero to the PC and sets the `STKUNF` bit, while the Stack Pointer remains at '0'. The `STKUNF` bit will remain set until cleared in software or a POR occurs.

Note: Returning a value of zero to the PC on an underflow has the effect of vectoring the program to the Reset vector, where the stack conditions can be verified and appropriate actions can be taken.

PIC18F6525/6621/8525/8621

REGISTER 4-2: STKPTR: STACK POINTER REGISTER

R/C-0	R/C-0	U-0	R/W-0	R/W-0	R/W-0	R/W-0	R/W-0	
STKFUL ⁽¹⁾	STKUNF ⁽¹⁾	—	SP4	SP3	SP2	SP1	SP0	
bit 7								bit 0

- bit 7 **STKFUL:** Stack Full Flag bit⁽¹⁾
1 = Stack became full or overflowed
0 = Stack has not become full or overflowed
- bit 6 **STKUNF:** Stack Underflow Flag bit⁽¹⁾
1 = Stack underflow occurred
0 = Stack underflow did not occur
- bit 5 **Unimplemented:** Read as '0'
- bit 4-0 **SP4:SP0:** Stack Pointer Location bits

Note 1: Bit 7 and bit 6 can only be cleared in user software or by a POR.

Legend:			
R = Readable bit	W = Writable bit	U = Unimplemented bit, read as '0'	
-n = Value at POR	'1' = Bit is set	'0' = Bit is cleared	x = Bit is unknown

FIGURE 4-4: RETURN ADDRESS STACK AND ASSOCIATED REGISTERS

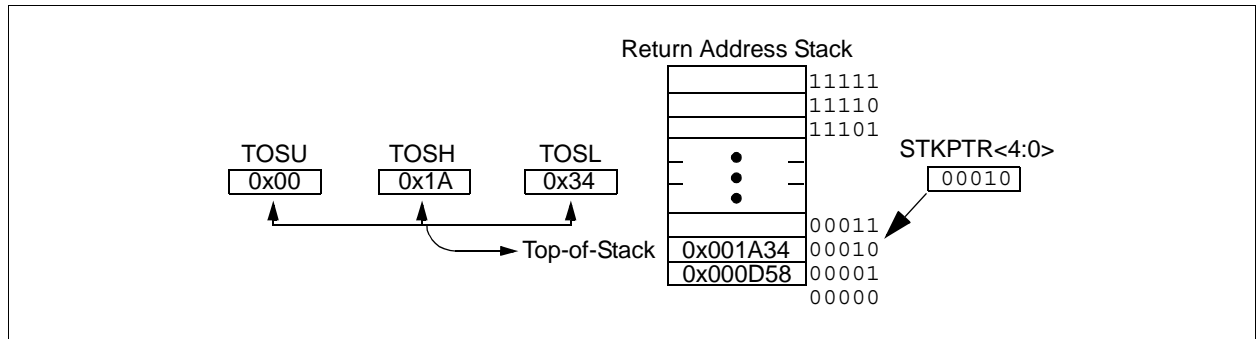

4.2.3 PUSH AND POP INSTRUCTIONS

Since the Top-of-Stack (TOS) is readable and writable, the ability to push values onto the stack and pull values off the stack, without disturbing normal program execution, is a desirable option. To push the current PC value onto the stack, a **PUSH** instruction can be executed. This will increment the Stack Pointer and load the current PC value onto the stack. TOSU, TOSH and TOSL can then be modified to place a return address on the stack.

The ability to pull the TOS value off of the stack and replace it with the value that was previously pushed onto the stack, without disturbing normal execution, is achieved by using the **POP** instruction. The **POP** instruction discards the current TOS by decrementing the Stack Pointer. The previous value pushed onto the stack then becomes the TOS value.

4.2.4 STACK FULL/UNDERFLOW RESETS

These Resets are enabled by programming the STVREN configuration bit. When the STVREN bit is disabled, a full or underflow condition will set the appropriate STKFUL or STKUNF bit, but not cause a device Reset. When the STVREN bit is enabled, a full or underflow condition will set the appropriate STKFUL or STKUNF bit and then cause a device Reset. The STKFUL or STKUNF bits are only cleared by the user software or a Power-on Reset.

PIC18F6525/6621/8525/8621

4.3 Fast Register Stack

A "fast interrupt return" option is available for interrupts. A fast register stack is provided for the STATUS, WREG and BSR registers and is only one in depth. The stack is not readable or writable and is loaded with the current value of the corresponding register when the processor vectors for an interrupt. The values in the registers are then loaded back into the working registers if the `FAST RETURN` instruction is used to return from the interrupt.

A low or high priority interrupt source will push values into the stack registers. If both low and high priority interrupts are enabled, the stack registers cannot be used reliably for low priority interrupts. If a high priority interrupt occurs while servicing a low priority interrupt, the stack register values stored by the low priority interrupt will be overwritten.

If high priority interrupts are not disabled during low priority interrupts, users must save the key registers in software during a low priority interrupt.

If no interrupts are used, the fast register stack can be used to restore the STATUS, WREG and BSR registers at the end of a subroutine call. To use the fast register stack for a subroutine call, a `FAST CALL` instruction must be executed.

Example 4-1 shows a source code example that uses the fast register stack.

EXAMPLE 4-1: FAST REGISTER STACK CODE EXAMPLE

```
CALL SUB1, FAST ;STATUS, WREG, BSR
                  ;SAVED IN FAST REGISTER
                  ;STACK
.
.
SUB1 .
.
RETURN FAST ;RESTORE VALUES SAVED
          ;IN FAST REGISTER STACK
```

4.4 PCL, PCLATH and PCLATU

The Program Counter (PC) specifies the address of the instruction to fetch for execution. The PC is 21 bits wide. The low byte is called the PCL register; this register is readable and writable. The high byte is called the PCH register. This register contains the PC<15:8> bits and is not directly readable or writable; updates to the PCH register may be performed through the PCLATH register. The upper byte is called PCU. This register contains the PC<20:16> bits and is not directly readable or writable; updates to the PCU register may be performed through the PCLATU register.

The PC addresses bytes in the program memory. To prevent the PC from becoming misaligned with word instructions, the LSB of the PCL is fixed to a value of '0'. The PC increments by 2 to address sequential instructions in the program memory.

The `CALL`, `RCALL`, `GOTO` and program branch instructions write to the program counter directly. For these instructions, the contents of PCLATH and PCLATU are not transferred to the program counter.

The contents of PCLATH and PCLATU will be transferred to the program counter by an operation that writes PCL. Similarly, the upper two bytes of the program counter will be transferred to PCLATH and PCLATU by an operation that reads PCL. This is useful for computed offsets to the PC (see **Section 4.8.1 "Computed GOTO"**).

4.5 Clocking Scheme/Instruction Cycle

The clock input (from OSC1) is internally divided by four to generate four non-overlapping quadrature clocks, namely Q1, Q2, Q3 and Q4. Internally, the Program Counter (PC) is incremented every Q1, the instruction is fetched from the program memory and latched into the Instruction Register (IR) in Q4. The instruction is decoded and executed during the following Q1 through Q4. The clocks and instruction execution flow are shown in Figure 4-5.

FIGURE 4-5: CLOCK/INSTRUCTION CYCLE

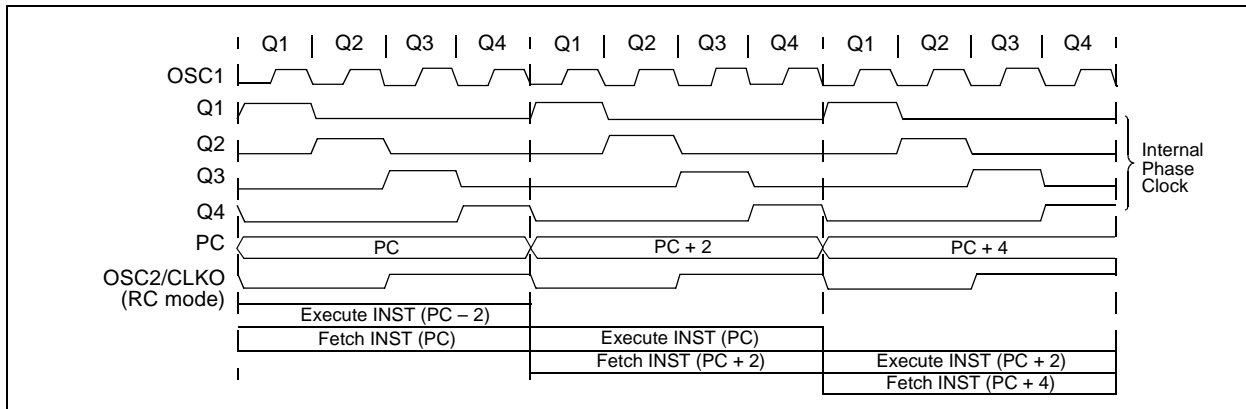

PIC18F6525/6621/8525/8621

4.6 Instruction Flow/Pipelining

An "Instruction Cycle" consists of four Q cycles (Q1, Q2, Q3 and Q4). The instruction fetch and execute are pipelined such that fetch takes one instruction cycle, while decode and execute take another instruction cycle. However, due to the pipelining, each instruction effectively executes in one cycle. If an instruction causes the program counter to change (e.g., GOTO), then two cycles are required to complete the instruction (Example 4-2).

A fetch cycle begins with the Program Counter (PC) incrementing in Q1.

In the execution cycle, the fetched instruction is latched into the "Instruction Register" (IR) in cycle Q1. This instruction is then decoded and executed during the Q2, Q3 and Q4 cycles. Data memory is read during Q2 (operand read) and written during Q4 (destination write).

EXAMPLE 4-2: INSTRUCTION PIPELINE FLOW

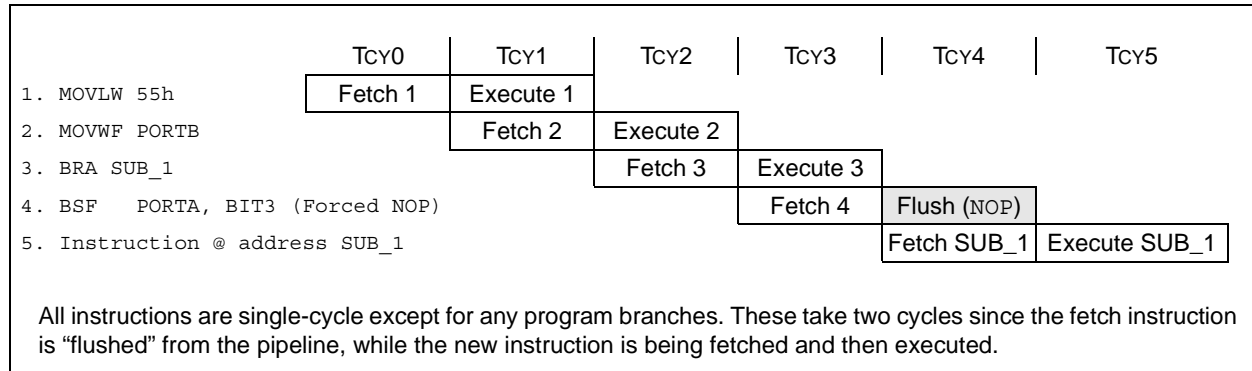

4.7 Instructions in Program Memory

The program memory is addressed in bytes. Instructions are stored as two bytes or four bytes in program memory. The Least Significant Byte of an instruction word is always stored in a program memory location with an even address (LSB = 0). Figure 4-6 shows an example of how instruction words are stored in the program memory. To maintain alignment with instruction boundaries, the PC increments in steps of 2 and the LSB will always read '0' (see Section 4.4 "PCL, PCLATH and PCLATU").

word boundaries, the data contained in the instruction is a word address. The word address is written to PC<20:1> which accesses the desired byte address in program memory. Instruction #2 in Figure 4-6 shows how the instruction "GOTO 000006h" is encoded in the program memory. Program branch instructions, which encode a relative address offset, operate in the same manner. The offset value stored in a branch instruction represents the number of single-word instructions that the PC will be offset by. Section 25.0 "Instruction Set Summary" provides further details of the instruction set.

The CALL and GOTO instructions have an absolute program memory address embedded into the instruction. Since instructions are always stored on

FIGURE 4-6: INSTRUCTIONS IN PROGRAM MEMORY

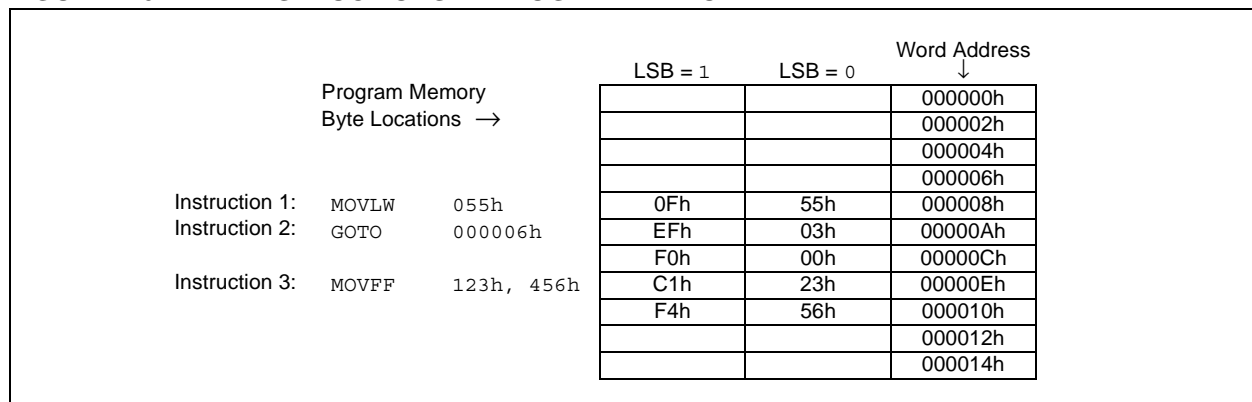

PIC18F6525/6621/8525/8621

4.7.1 TWO-WORD INSTRUCTIONS

The PIC18F6525/6621/8525/8621 devices have four two-word instructions: MOVFF, CALL, GOTO and LFSR. The second word of these instructions has the 4 MSBs set to '1's and is a special kind of NOP instruction. The lower 12 bits of the second word contain data to be used by the instruction. If the first word of the instruction is executed, the data in the second word is accessed.

If the second word of the instruction is executed by itself (first word was skipped), it will execute as a NOP. This action is necessary when the two-word instruction is preceded by a conditional instruction that changes the PC. A program example that demonstrates this concept is shown in Example 4-3. Refer to **Section 25.0 "Instruction Set Summary"** for further details of the instruction set.

EXAMPLE 4-3: TWO-WORD INSTRUCTIONS

CASE 1:	
Object Code	Source Code
0110 0110 0000 0000	TSTFSZ REG1 ; is RAM location 0?
1100 0001 0010 0011	MOVFF REG1, REG2 ; No, execute 2-word instruction
1111 0100 0101 0110	; 2nd operand holds address of REG2
0010 0100 0000 0000	ADDWF REG3 ; continue code
CASE 2:	
Object Code	Source Code
0110 0110 0000 0000	TSTFSZ REG1 ; is RAM location 0?
1100 0001 0010 0011	MOVFF REG1, REG2 ; Yes
1111 0100 0101 0110	; 2nd operand becomes NOP
0010 0100 0000 0000	ADDWF REG3 ; continue code

4.8 Look-up Tables

Look-up tables are implemented two ways. These are:

- Computed GOTO
- Table Reads

4.8.1 COMPUTED GOTO

A computed GOTO is accomplished by adding an offset to the program counter (ADDWF PCL).

A look-up table can be formed with an ADDWF PCL instruction and a group of RETLW 0xnn instructions. WREG is loaded with an offset into the table before executing a call to that table. The first instruction of the called

routine is the ADDWF PCL instruction. The next instruction executed will be one of the RETLW 0xnn instructions that returns the value 0xnn to the calling function.

The offset value (value in WREG) specifies the number of bytes that the program counter should advance.

In this method, only one data byte may be stored in each instruction location and room on the return address stack is required.

Note: The ADDWF PCL instruction does not update PCLATH and PCLATU. A read operation on PCL must be performed to update PCLATH and PCLATU.

EXAMPLE 4-4: COMPUTED GOTO USING AN OFFSET VALUE

```
MAIN:  ORG    0x0000
        MOVLW 0x00
        CALL  TABLE
...
        ORG    0x8000
TABLE  MOVF   PCL, F    ; A simple read of PCL will update PCLATH, PCLATU
        RLNCF W, W     ; Multiply by 2 to get correct offset in table
        ADDWF PCL      ; Add the modified offset to force jump into table
        RETLW 'A'
        RETLW 'B'
        RETLW 'C'
        RETLW 'D'
        RETLW 'E'
        END
```

4.8.2 TABLE READS/TABLE WRITES

A better method of storing data in program memory allows 2 bytes of data to be stored in each instruction location.

Look-up table data may be stored 2 bytes per program word by using table reads and writes. The Table Pointer (TBLPTR) specifies the byte address and the Table Latch (TABLAT) contains the data that is read from, or written to program memory. Data is transferred to/from program memory, one byte at a time.

A description of the table read/table write operation is shown in **Section 5.0 “Flash Program Memory”**.

4.9 Data Memory Organization

The data memory is implemented as static RAM. Each register in the data memory has a 12-bit address, allowing up to 4096 bytes of data memory. Figure 4-7 shows the data memory organization for the PIC18F6525/6621/8525/8621 devices.

The data memory map is divided into 16 banks that contain 256 bytes each. The lower 4 bits of the Bank Select Register (BSR<3:0>) select which bank will be accessed. The upper 4 bits for the BSR are not implemented.

The data memory contains Special Function Registers (SFR) and General Purpose Registers (GPR). The SFRs are used for control and status of the controller and peripheral functions, while GPRs are used for data storage and scratch pad operations in the user's application. The SFRs start at the last location of Bank 15 (0FFFh) and extend downwards. Any remaining space beyond the SFRs in the bank may be implemented as GPRs. GPRs start at the first location of Bank 0 and grow upwards. Any read of an unimplemented location will read as '0's.

The entire data memory may be accessed directly or indirectly. Direct addressing may require the use of the BSR register. Indirect addressing requires the use of a File Select Register (FSRn) and a corresponding Indirect File Operand (INDFn). Each FSR holds a 12-bit address value that can be used to access any location in the data memory map without banking.

The instruction set and architecture allow operations across all banks. This may be accomplished by indirect addressing or by the use of the MOVFF instruction. The MOVFF instruction is a two-word/two-cycle instruction that moves a value from one register to another.

To ensure that commonly used registers (SFRs and select GPRs) can be accessed in a single cycle regardless of the current BSR values, an Access Bank is implemented. A segment of Bank 0 and a segment of Bank 15 comprise the Access RAM. **Section 4.10 “Access Bank”** provides a detailed description of the Access RAM.

4.9.1 GENERAL PURPOSE REGISTER FILE

The register file can be accessed either directly or indirectly. Indirect addressing operates using a File Select Register and corresponding Indirect File Operand. The operation of indirect addressing is shown in **Section 4.12 “Indirect Addressing, INDF and FSR Registers”**.

Enhanced MCU devices may have banked memory in the GPR area. GPRs are not initialized by a Power-on Reset and are unchanged on all other Resets.

Data RAM is available for use as General Purpose Registers by all instructions. The top section of Bank 15 (F60h to FFFh) contains SFRs. All other banks of data memory contain GPRs, starting with Bank 0.

4.9.2 SPECIAL FUNCTION REGISTERS

The Special Function Registers (SFRs) are registers used by the CPU and peripheral modules for controlling the desired operation of the device. These registers are implemented as static RAM. A list of these registers is given in Table 4-2 and Table 4-3.

The SFRs can be classified into two sets: those associated with the “core” function and those related to the peripheral functions. Those registers related to the “core” are described in this section, while those related to the operation of the peripheral features are described in the section of that peripheral feature. The SFRs are typically distributed among the peripherals whose functions they control.

The unused SFR locations are unimplemented and read as '0's. The addresses for the SFRs are listed in Table 4-2.

PIC18F6525/6621/8525/8621

FIGURE 4-7: DATA MEMORY MAP FOR PIC18F6525/6621/8525/8621 DEVICES

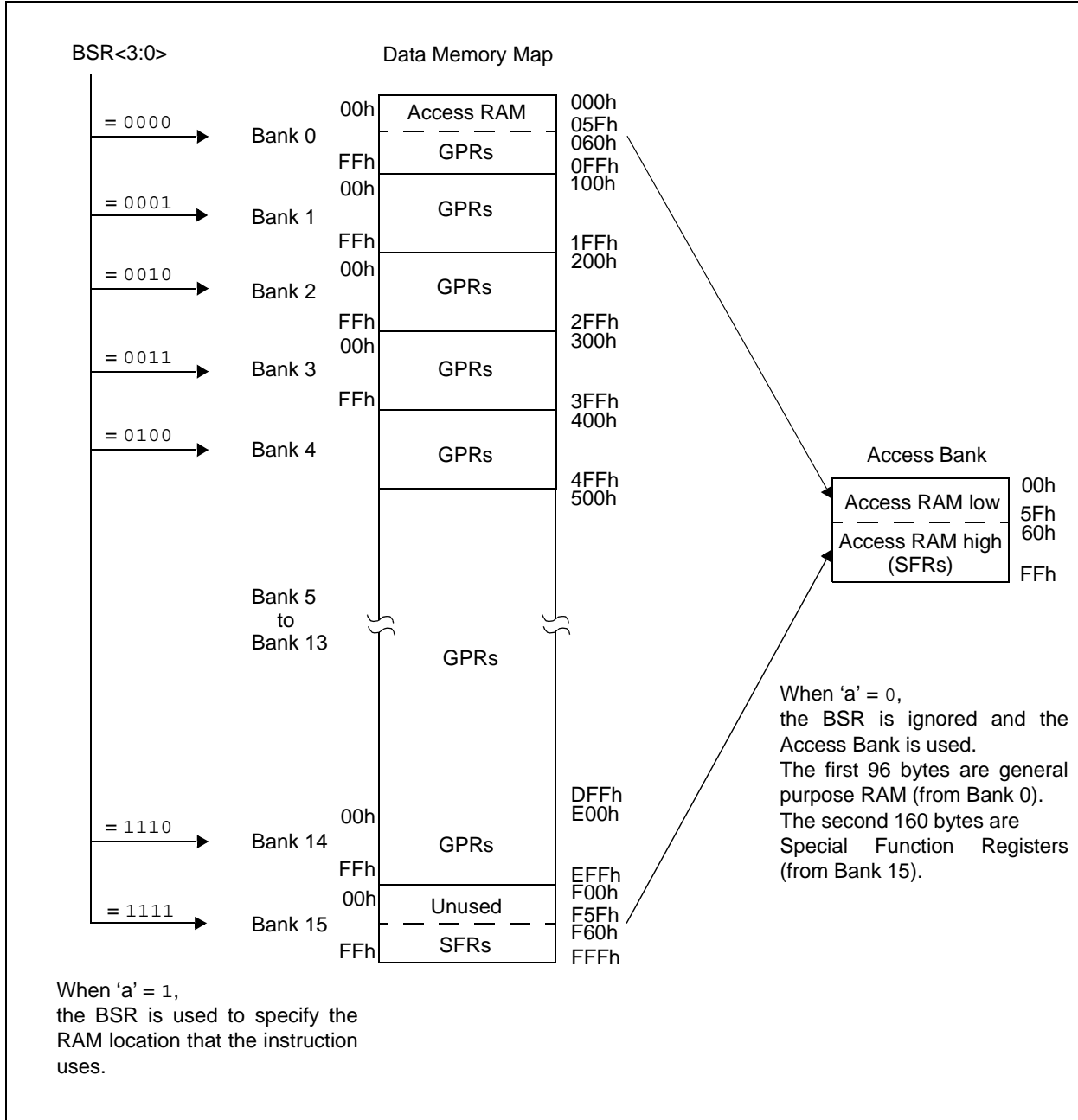

PIC18F6525/6621/8525/8621

TABLE 4-2: SPECIAL FUNCTION REGISTER MAP

Address	Name	Address	Name	Address	Name	Address	Name
FFFh	TOSU	FDFh	INDF2 ⁽³⁾	FBFh	CCPR1H	F9Fh	IPR1
FFEh	TOSH	FDEh	POSTINC2 ⁽³⁾	FBEh	CCPR1L	F9Eh	PIR1
FFDh	TOSL	FDDh	POSTDEC2 ⁽³⁾	FBDh	CCP1CON	F9Dh	PIE1
FFCh	STKPTR	FDCh	PREINC2 ⁽³⁾	FBCh	CCPR2H	F9Ch	MEMCON ⁽²⁾
FFBh	PCLATU	FDBh	PLUSW2 ⁽³⁾	FBBh	CCPR2L	F9Bh	— ⁽¹⁾
FFAh	PCLATH	FDAh	FSR2H	FBAh	CCP2CON	F9Ah	TRISJ ⁽²⁾
FF9h	PCL	FD9h	FSR2L	FB9h	CCPR3H	F99h	TRISH ⁽²⁾
FF8h	TBLPTRU	FD8h	STATUS	FB8h	CCPR3L	F98h	TRISG
FF7h	TBLPTRH	FD7h	TMR0H	FB7h	CCP3CON	F97h	TRISF
FF6h	TBLPTRL	FD6h	TMR0L	FB6h	ECCP1AS	F96h	TRISE
FF5h	TABLAT	FD5h	T0CON	FB5h	CVRCON	F95h	TRISD
FF4h	PRODH	FD4h	— ⁽¹⁾	FB4h	CMCON	F94h	TRISC
FF3h	PRODL	FD3h	OSCCON	FB3h	TMR3H	F93h	TRISB
FF2h	INTCON	FD2h	LVDCON	FB2h	TMR3L	F92h	TRISA
FF1h	INTCON2	FD1h	WDTCON	FB1h	T3CON	F91h	LATJ ⁽²⁾
FF0h	INTCON3	FD0h	RCON	FB0h	PSPCON ⁽⁴⁾	F90h	LATH ⁽²⁾
FEFh	INDF0 ⁽³⁾	FCFh	TMR1H	FAFh	SPBRG1	F8Fh	LATG
FEeh	POSTINC0 ⁽³⁾	FCEh	TMR1L	FAEh	RCREG1	F8Eh	LATF
FEDh	POSTDEC0 ⁽³⁾	FCDh	T1CON	FADh	TXREG1	F8Dh	LATE
FECh	PREINC0 ⁽³⁾	FCCh	TMR2	FACh	TXSTA1	F8Ch	LATD
FEBh	PLUSW0 ⁽³⁾	FCBh	PR2	FABh	RCSTA1	F8Bh	LATC
FEAh	FSR0H	FCAh	T2CON	FAAh	EEADRH	F8Ah	LATB
FE9h	FSR0L	FC9h	SSPBUF	FA9h	EEADR	F89h	LATA
FE8h	WREG	FC8h	SSPADD	FA8h	EEDATA	F88h	PORTJ ⁽²⁾
FE7h	INDF1 ⁽³⁾	FC7h	SSPSTAT	FA7h	EECON2	F87h	PORTH ⁽²⁾
FE6h	POSTINC1 ⁽³⁾	FC6h	SSPCON1	FA6h	EECON1	F86h	PORTG
FE5h	POSTDEC1 ⁽³⁾	FC5h	SSPCON2	FA5h	IPR3	F85h	PORTF
FE4h	PREINC1 ⁽³⁾	FC4h	ADRESH	FA4h	PIR3	F84h	PORTE
FE3h	PLUSW1 ⁽³⁾	FC3h	ADRESL	FA3h	PIE3	F83h	PORTD
FE2h	FSR1H	FC2h	ADCON0	FA2h	IPR2	F82h	PORTC
FE1h	FSR1L	FC1h	ADCON1	FA1h	PIR2	F81h	PORTB
FE0h	BSR	FC0h	ADCON2	FA0h	PIE2	F80h	PORTA

- Note 1:** Unimplemented registers are read as '0'.
- Note 2:** This register is not available on PIC18F6525/6621 devices and reads as '0'.
- Note 3:** This is not a physical register.
- Note 4:** Enabled only in Microcontroller mode for PIC18F8525/8621 devices.

PIC18F6525/6621/8525/8621

TABLE 4-2: SPECIAL FUNCTION REGISTER MAP (CONTINUED)

Address	Name	Address	Name	Address	Name	Address	Name
F7Fh	SPBRGH1	F5Fh	__ ⁽¹⁾	F3Fh	__ ⁽¹⁾	F1Fh	__ ⁽¹⁾
F7Eh	BAUDCON1	F5Eh	__ ⁽¹⁾	F3Eh	__ ⁽¹⁾	F1Eh	__ ⁽¹⁾
F7Dh	SPBRGH2	F5Dh	__ ⁽¹⁾	F3Dh	__ ⁽¹⁾	F1Dh	__ ⁽¹⁾
F7Ch	BAUDCON2	F5Ch	__ ⁽¹⁾	F3Ch	__ ⁽¹⁾	F1Ch	__ ⁽¹⁾
F7Bh	__ ⁽¹⁾	F5Bh	__ ⁽¹⁾	F3Bh	__ ⁽¹⁾	F1Bh	__ ⁽¹⁾
F7Ah	__ ⁽¹⁾	F5Ah	__ ⁽¹⁾	F3Ah	__ ⁽¹⁾	F1Ah	__ ⁽¹⁾
F79h	ECCP1DEL	F59h	__ ⁽¹⁾	F39h	__ ⁽¹⁾	F19h	__ ⁽¹⁾
F78h	TMR4	F58h	__ ⁽¹⁾	F38h	__ ⁽¹⁾	F18h	__ ⁽¹⁾
F77h	PR4	F57h	__ ⁽¹⁾	F37h	__ ⁽¹⁾	F17h	__ ⁽¹⁾
F76h	T4CON	F56h	__ ⁽¹⁾	F36h	__ ⁽¹⁾	F16h	__ ⁽¹⁾
F75h	CCPR4H	F55h	__ ⁽¹⁾	F35h	__ ⁽¹⁾	F15h	__ ⁽¹⁾
F74h	CCPR4L	F54h	__ ⁽¹⁾	F34h	__ ⁽¹⁾	F14h	__ ⁽¹⁾
F73h	CCP4CON	F53h	__ ⁽¹⁾	F33h	__ ⁽¹⁾	F13h	__ ⁽¹⁾
F72h	CCPR5H	F52h	__ ⁽¹⁾	F32h	__ ⁽¹⁾	F12h	__ ⁽¹⁾
F71h	CCPR5L	F51h	__ ⁽¹⁾	F31h	__ ⁽¹⁾	F11h	__ ⁽¹⁾
F70h	CCP5CON	F50h	__ ⁽¹⁾	F30h	__ ⁽¹⁾	F10h	__ ⁽¹⁾
F6Fh	SPBRG2	F4Fh	__ ⁽¹⁾	F2Fh	__ ⁽¹⁾	F0Fh	__ ⁽¹⁾
F6Eh	RCREG2	F4Eh	__ ⁽¹⁾	F2Eh	__ ⁽¹⁾	F0Eh	__ ⁽¹⁾
F6Dh	TXREG2	F4Dh	__ ⁽¹⁾	F2Dh	__ ⁽¹⁾	F0Dh	__ ⁽¹⁾
F6Ch	TXSTA2	F4Ch	__ ⁽¹⁾	F2Ch	__ ⁽¹⁾	F0Ch	__ ⁽¹⁾
F6Bh	RCSTA2	F4Bh	__ ⁽¹⁾	F2Bh	__ ⁽¹⁾	F0Bh	__ ⁽¹⁾
F6Ah	ECCP3AS	F4Ah	__ ⁽¹⁾	F2Ah	__ ⁽¹⁾	F0Ah	__ ⁽¹⁾
F69h	ECCP3DEL	F49h	__ ⁽¹⁾	F29h	__ ⁽¹⁾	F09h	__ ⁽¹⁾
F68h	ECCP2AS	F48h	__ ⁽¹⁾	F28h	__ ⁽¹⁾	F08h	__ ⁽¹⁾
F67h	ECCP2DEL	F47h	__ ⁽¹⁾	F27h	__ ⁽¹⁾	F07h	__ ⁽¹⁾
F66h	__ ⁽¹⁾	F46h	__ ⁽¹⁾	F26h	__ ⁽¹⁾	F06h	__ ⁽¹⁾
F65h	__ ⁽¹⁾	F45h	__ ⁽¹⁾	F25h	__ ⁽¹⁾	F05h	__ ⁽¹⁾
F64h	__ ⁽¹⁾	F44h	__ ⁽¹⁾	F24h	__ ⁽¹⁾	F04h	__ ⁽¹⁾
F63h	__ ⁽¹⁾	F43h	__ ⁽¹⁾	F23h	__ ⁽¹⁾	F03h	__ ⁽¹⁾
F62h	__ ⁽¹⁾	F42h	__ ⁽¹⁾	F22h	__ ⁽¹⁾	F02h	__ ⁽¹⁾
F61h	__ ⁽¹⁾	F41h	__ ⁽¹⁾	F21h	__ ⁽¹⁾	F01h	__ ⁽¹⁾
F60h	__ ⁽¹⁾	F40h	__ ⁽¹⁾	F20h	__ ⁽¹⁾	F00h	__ ⁽¹⁾

- Note** 1: Unimplemented registers are read as '0'.
 2: This register is not available on PIC18F6525/6621 devices and reads as '0'.
 3: This is not a physical register.
 4: Enabled only in Microcontroller mode for PIC18F8525/8621 devices.

PIC18F6525/6621/8525/8621

TABLE 4-3: REGISTER FILE SUMMARY

File Name	Bit 7	Bit 6	Bit 5	Bit 4	Bit 3	Bit 2	Bit 1	Bit 0	Value on POR, BOR	Details on page:
TOSU	—	—	—	Top-of-Stack Upper Byte (TOS<20:16>)					---0 0000	32, 42
TOSH	Top-of-Stack High Byte (TOS<15:8>)								0000 0000	32, 42
TOSL	Top-of-Stack Low Byte (TOS<7:0>)								0000 0000	32, 42
STKPTR	STKFUL	STKUNF	—	Return Stack Pointer				00-0 0000	32, 43	
PCLATU	—	—	—	Holding Register for PC<20:16>					---0 0000	32, 44
PCLATH	Holding Register for PC<15:8>								0000 0000	32, 44
PCL	PC Low Byte (PC<7:0>)								0000 0000	32, 44
TBLPTRU	—	—	bit 21 ⁽²⁾	Program Memory Table Pointer Upper Byte (TBLPTR<20:16>)					--00 0000	32, 69
TBLPTRH	Program Memory Table Pointer High Byte (TBLPTR<15:8>)								0000 0000	32, 69
TBLPTRL	Program Memory Table Pointer Low Byte (TBLPTR<7:0>)								0000 0000	32, 69
TABLAT	Program Memory Table Latch								0000 0000	32, 69
PRODH	Product Register High Byte								xxxx xxxx	32, 85
PRODL	Product Register Low Byte								xxxx xxxx	32, 85
INTCON	GIE/GIEH	PEIE/GIEL	TMR0IE	INT0IE	RBIE	TMR0IF	INT0IF	RBIF	0000 000x	32, 89
INTCON2	RBP _U	INTEDG0	INTEDG1	INTEDG2	INTEDG3	TMR0IP	INT3IP	RBIP	1111 1111	32, 90
INTCON3	INT2IP	INT1IP	INT3IE	INT2IE	INT1IE	INT3IF	INT2IF	INT1IF	1100 0000	32, 91
INDF0	Uses contents of FSR0 to address data memory – value of FSR0 not changed (not a physical register)								N/A	56
POSTINC0	Uses contents of FSR0 to address data memory – value of FSR0 post-incremented (not a physical register)								N/A	56
POSTDEC0	Uses contents of FSR0 to address data memory – value of FSR0 post-decremented (not a physical register)								N/A	56
PREINC0	Uses contents of FSR0 to address data memory – value of FSR0 pre-incremented (not a physical register)								N/A	56
PLUSW0	Uses contents of FSR0 to address data memory – value of FSR0 pre-incremented (not a physical register) – value of FSR0 offset by value in WREG								N/A	56
FSR0H	—	—	—	—	Indirect Data Memory Address Pointer 0 High Byte				---- 0000	32, 56
FSR0L	Indirect Data Memory Address Pointer 0 Low Byte								xxxx xxxx	32, 56
WREG	Working Register								xxxx xxxx	32
INDF1	Uses contents of FSR1 to address data memory – value of FSR1 not changed (not a physical register)								N/A	56
POSTINC1	Uses contents of FSR1 to address data memory – value of FSR1 post-incremented (not a physical register)								N/A	56
POSTDEC1	Uses contents of FSR1 to address data memory – value of FSR1 post-decremented (not a physical register)								N/A	56
PREINC1	Uses contents of FSR1 to address data memory – value of FSR1 pre-incremented (not a physical register)								N/A	56
PLUSW1	Uses contents of FSR1 to address data memory – value of FSR1 pre-incremented (not a physical register) – value of FSR1 offset by value in WREG								N/A	56
FSR1H	—	—	—	—	Indirect Data Memory Address Pointer 1 High Byte				---- 0000	32, 56
FSR1L	Indirect Data Memory Address Pointer 1 Low Byte								xxxx xxxx	33, 56
BSR	—	—	—	—	Bank Select Register				---- 0000	33, 55
INDF2	Uses contents of FSR2 to address data memory – value of FSR2 not changed (not a physical register)								N/A	56
POSTINC2	Uses contents of FSR2 to address data memory – value of FSR2 post-incremented (not a physical register)								N/A	56
POSTDEC2	Uses contents of FSR2 to address data memory – value of FSR2 post-decremented (not a physical register)								N/A	56

Legend: x = unknown, u = unchanged, – = unimplemented, q = value depends on condition

Note 1: RA6 and associated bits are configured as a port pin in RCIO and ECIO Oscillator modes only and read '0' in all other oscillator modes.

2: Bit 21 of the TBLPTRU allows access to the device configuration bits.

3: These registers are unused on PIC18F6525/6621 devices and read as '0'.

4: RG5 is available only if MCLR function is disabled in configuration.

5: Enabled only in Microcontroller mode for PIC18F8525/8621 devices.

PIC18F6525/6621/8525/8621

TABLE 4-3: REGISTER FILE SUMMARY (CONTINUED)

File Name	Bit 7	Bit 6	Bit 5	Bit 4	Bit 3	Bit 2	Bit 1	Bit 0	Value on POR, BOR	Details on page:
PREINC2	Uses contents of FSR2 to address data memory – value of FSR2 pre-incremented (not a physical register)								N/A	56
PLUSW2	Uses contents of FSR2 to address data memory – value of FSR2 pre-incremented (not a physical register) – value of FSR2 offset by value in WREG								N/A	56
FSR2H	—	—	—	—	Indirect Data Memory Address Pointer 2 High Byte				---- 0000	33, 56
FSR2L	Indirect Data Memory Address Pointer 2 Low Byte								xxxx xxxx	33, 56
STATUS	—	—	—	N	OV	Z	DC	C	---x xxxx	33, 58
TMR0H	Timer0 Register High Byte								0000 0000	33, 133
TMR0L	Timer0 Register Low Byte								xxxx xxxx	33, 133
T0CON	TMR0ON	T08BIT	T0CS	T0SE	PSA	T0PS2	T0PS1	T0PS0	1111 1111	33, 131
OSCCON	—	—	—	—	LOCK	PLLEN	SCS1	SCS0	---- 0000	25, 33
LVDCON	—	—	IRVST	LVDEN	LVDL3	LVDL2	LVDL1	LVDL0	--00 0101	33, 255
WDTCON	—	—	—	—	—	—	—	SWDTEN	---- --0	33, 267
RCON	IPEN	—	—	\overline{RI}	\overline{TO}	\overline{PD}	\overline{POR}	\overline{BOR}	0--1 11qq	33, 59, 101
TMR1H	Timer1 Register High Byte								xxxx xxxx	33, 139
TMR1L	Timer1 Register Low Byte								xxxx xxxx	33, 139
T1CON	RD16	—	T1CKPS1	T1CKPS0	T1OSCEN	$\overline{T1SYNC}$	TMR1CS	TMR1ON	0-00 0000	33, 139
TMR2	Timer2 Register								0000 0000	33, 142
PR2	Timer2 Period Register								1111 1111	33, 142
T2CON	—	T2OUTPS3	T2OUTPS2	T2OUTPS1	T2OUTPS0	TMR2ON	T2CKPS1	T2CKPS0	-000 0000	33, 142
SSPBUF	MSSP Receive Buffer/Transmit Register								xxxx xxxx	33, 181
SSPADD	MSSP Address Register in I ² C Slave mode. MSSP Baud Rate Reload Register in I ² C Master mode.								0000 0000	33, 181
SSPSTAT	SMP	CKE	$\overline{D/A}$	P	S	$\overline{R/W}$	UA	BF	0000 0000	33, 174
SSPCON1	WCOL	SSPOV	SSPEN	CKP	SSPM3	SSPM2	SSPM1	SSPM0	0000 0000	33, 175
SSPCON2	GCEN	ACKSTAT	ACKDT	ACKEN	RCEN	PEN	RSEN	SEN	0000 0000	33, 185
ADRESH	A/D Result Register High Byte								xxxx xxxx	33, 241
ADRESL	A/D Result Register Low Byte								xxxx xxxx	33, 241
ADCON0	—	—	CHS3	CHS2	CHS1	CHS0	$\overline{GO/DONE}$	ADON	--00 0000	34, 233
ADCON1	—	—	VCFG1	VCFG0	PCFG3	PCFG2	PCFG1	PCFG0	--00 0000	34, 234
ADCON2	ADFM	—	ACQT2	ACQT1	ACQT0	ADCS2	ADCS1	ADCS0	0-00 0000	34, 235
CCPR1H	Enhanced Capture/Compare/PWM Register 1 High Byte								xxxx xxxx	34, 172
CCPR1L	Enhanced Capture/Compare/PWM Register 1 Low Byte								xxxx xxxx	34, 172
CCP1CON	P1M1	P1M0	DC1B1	DC1B0	CCP1M3	CCP1M2	CCP1M1	CCP1M0	0000 0000	34, 157
CCPR2H	Enhanced Capture/Compare/PWM Register 2 High Byte								xxxx xxxx	34, 172
CCPR2L	Enhanced Capture/Compare/PWM Register 2 Low Byte								xxxx xxxx	34, 172
CCP2CON	P2M1	P2M0	DC2B1	DC2B0	CCP2M3	CCP2M2	CCP2M1	CCP2M0	0000 0000	34, 157
CCPR3H	Enhanced Capture/Compare/PWM Register 3 High Byte								xxxx xxxx	34, 172
CCPR3L	Enhanced Capture/Compare/PWM Register 3 Low Byte								xxxx xxxx	34, 172
CCP3CON	P3M1	P3M0	DC3B1	DC3B0	CCP3M3	CCP3M2	CCP3M1	CCP3M0	0000 0000	34, 157
ECCP1AS	ECCP1ASE	ECCP1AS2	ECCP1AS1	ECCP1AS0	PSS1AC1	PSS1AC0	PSS1BD1	PSS1BD0	0000 0000	34, 169
CVRCON	CVREN	CVROE	CVRR	CVRSS	CVR3	CVR2	CVR1	CVR0	0000 0000	34, 249

Legend: x = unknown, u = unchanged, – = unimplemented, q = value depends on condition

Note 1: RA6 and associated bits are configured as a port pin in RCIO and ECIO Oscillator modes only and read '0' in all other oscillator modes.

2: Bit 21 of the TBLPTRU allows access to the device configuration bits.

3: These registers are unused on PIC18F6525/6621 devices and read as '0'.

4: RG5 is available only if MCLR function is disabled in configuration.

5: Enabled only in Microcontroller mode for PIC18F8525/8621 devices.

PIC18F6525/6621/8525/8621

TABLE 4-3: REGISTER FILE SUMMARY (CONTINUED)

File Name	Bit 7	Bit 6	Bit 5	Bit 4	Bit 3	Bit 2	Bit 1	Bit 0	Value on POR, BOR	Details on page:
CMCON	C2OUT	C1OUT	C2INV	C1INV	CIS	CM2	CM1	CM0	0000 0000	34, 243
TMR3H	Timer3 Register High Byte								xxxx xxxx	34, 145
TMR3L	Timer3 Register Low Byte								xxxx xxxx	34, 145
T3CON	RD16	T3CCP2	T3CKPS1	T3CKPS0	T3CCP1	T3SYN \overline{C}	TMR3CS	TMR3ON	0000 0000	34, 145
PSPCON ⁽⁵⁾	IBF	OBF	IBOV	PSPMODE	—	—	—	—	0000 ----	34, 129
SPBRG1	Enhanced USART1 Baud Rate Generator Register Low Byte								0000 0000	34, 217
RCREG1	Enhanced USART1 Receive Register								0000 0000	34, 224
TXREG1	Enhanced USART1 Transmit Register								0000 0000	34, 222
TXSTA1	CSRC	TX9	TXEN	SYNC	SENCB	BRGH	TRMT	TX9D	0000 0010	34, 214
RCSTA1	SPEN	RX9	SREN	CREN	ADDEN	FERR	OERR	RX9D	0000 000x	34, 215
EEADRH	—	—	—	—	—	—	EE Addr Register High		---- --00	34, 83
EEADR	Data EEPROM Address Register								0000 0000	34, 83
EEDATA	Data EEPROM Data Register								0000 0000	34, 83
EECON2	Data EEPROM Control Register 2 (not a physical register)								---- ----	34, 83
EECON1	EEPGD	CFGS	—	FREE	WRERR	WREN	WR	RD	xx-0 x000	34, 80
IPR3	—	—	RC2IP	TX2IP	TMR4IP	CCP5IP	CCP4IP	CCP3IP	--11 1111	35, 100
PIR3	—	—	RC2IF	TX2IF	TMR4IF	CCP5IF	CCP4IF	CCP3IF	--00 0000	35, 94
PIE3	—	—	RC2IE	TX2IE	TMR4IE	CCP5IE	CCP4IE	CCP3IE	--00 0000	35, 97
IPR2	—	CMIP	—	EEIP	BCLIP	LVDIP	TMR3IP	CCP2IP	-1-1 1111	35, 99
PIR2	—	CMIF	—	EEIF	BCLIF	LVDIF	TMR3IF	CCP2IF	-0-0 0000	35, 93
PIE2	—	CMIE	—	EEIE	BCLIE	LVDIE	TMR3IE	CCP2IE	-0-0 0000	35, 96
IPR1	PSPIP ⁽⁵⁾	ADIP	RC1IP	TX1IP	SSPIP	CCP1IP	TMR2IP	TMR1IP	1111 1111	35, 98
PIR1	PSPIF ⁽⁵⁾	ADIF	RC1IF	TX1IF	SSPIF	CCP1IF	TMR2IF	TMR1IF	0000 0000	35, 92
PIE1	PSPIE ⁽⁵⁾	ADIE	RC1IE	TX1IE	SSPIE	CCP1IE	TMR2IE	TMR1IE	0000 0000	35, 95
MEMCON ⁽³⁾	EBDIS	—	WAIT1	WAIT0	—	—	WM1	WM0	0-00 --00	35, 71
TRISJ ⁽³⁾	Data Direction Control Register for PORTJ								1111 1111	35, 127
TRISH ⁽³⁾	Data Direction Control Register for PORTH								1111 1111	35, 124
TRISG	—	—	—	Data Direction Control Register for PORTG				---	1 1111	35, 119
TRISF	Data Direction Control Register for PORTF								1111 1111	35, 116
TRISE	Data Direction Control Register for PORTE								1111 1111	35, 113
TRISD	Data Direction Control Register for PORTD								1111 1111	35, 110
TRISC	Data Direction Control Register for PORTC								1111 1111	35, 108
TRISB	Data Direction Control Register for PORTB								1111 1111	35, 105
TRISA	—	TRISA6 ⁽¹⁾	Data Direction Control Register for PORTA					-111	1111	35, 121
LATJ ⁽³⁾	Read PORTJ Data Latch, Write PORTJ Data Latch								xxxx xxxx	35, 127
LATH ⁽³⁾	Read PORTH Data Latch, Write PORTH Data Latch								xxxx xxxx	35, 124
LATG	—	—	—	Read PORTG Data Latch, Write PORTG Data Latch				---x	xxxx	35, 121
LATF	Read PORTF Data Latch, Write PORTF Data Latch								xxxx xxxx	35, 119
LATE	Read PORTE Data Latch, Write PORTE Data Latch								xxxx xxxx	35, 116
LATD	Read PORTD Data Latch, Write PORTD Data Latch								xxxx xxxx	35, 113
LATC	Read PORTC Data Latch, Write PORTC Data Latch								xxxx xxxx	35, 110
LATB	Read PORTB Data Latch, Write PORTB Data Latch								xxxx xxxx	35, 108
LATA	—	LATA6 ⁽¹⁾	Read PORTA Data Latch, Write PORTA Data Latch ⁽¹⁾					-xxx	xxxx	35, 105

Legend: x = unknown, u = unchanged, — = unimplemented, \overline{q} = value depends on condition

- Note 1:** RA6 and associated bits are configured as a port pin in RCIO and ECIO Oscillator modes only and read '0' in all other oscillator modes.
- 2:** Bit 21 of the TBLPTRU allows access to the device configuration bits.
- 3:** These registers are only used on PIC18F6525/6621 devices and read as '0'.
- 4:** RG5 is available only if MCLR function is disabled in configuration.
- 5:** Enabled only in Microcontroller mode for PIC18F8525/8621 devices.

PIC18F6525/6621/8525/8621

TABLE 4-3: REGISTER FILE SUMMARY (CONTINUED)

File Name	Bit 7	Bit 6	Bit 5	Bit 4	Bit 3	Bit 2	Bit 1	Bit 0	Value on POR, BOR	Details on page:		
PORTJ ⁽³⁾	Read PORTJ pins, Write PORTJ Data Latch								xxxx xxxx	35, 127		
PORTH ⁽³⁾	Read PORTH pins, Write PORTH Data Latch								0000 xxxxx	35, 124		
PORTG	—	—	RG5 ⁽⁴⁾	Read PORTG pins, Write PORTG Data Latch							--xx xxxxx	36, 121
PORTF	Read PORTF pins, Write PORTF Data Latch								x000 0000	36, 119		
PORTE	Read PORTE pins, Write PORTE Data Latch								xxxx xxxxx	36, 116		
PORTD	Read PORTD pins, Write PORTD Data Latch								xxxx xxxxx	36, 113		
PORTC	Read PORTC pins, Write PORTC Data Latch								xxxx xxxxx	36, 110		
PORTB	Read PORTB pins, Write PORTB Data Latch								xxxx xxxxx	36, 108		
PORTA	—	RA6 ⁽¹⁾	Read PORTA pins, Write PORTA Data Latch ⁽¹⁾							-x0x 0000	36, 105	
SPBRGH1	Enhanced USART1 Baud Rate Generator Register High Byte								0000 0000	36, 217		
BAUDCON1	—	RCIDL	—	SCKP	BRG16	—	WUE	ABDEN	-1-0 0-00	36, 216		
SPBRGH2	Enhanced USART2 Baud Rate Generator Register High Byte								0000 0000	36, 217		
BAUDCON2	—	RCIDL	—	SCKP	BRG16	—	WUE	ABDEN	-1-0 0-00	36, 216		
ECCP1DEL	P1RSEN	P1DC6	P1DC5	P1DC4	P1DC3	P1DC2	P1DC1	P1DC0	0000 0000	36, 168		
TMR4	Timer4 Register								0000 0000	36, 148		
PR4	Timer4 Period Register								1111 1111	36, 148		
T4CON	—	T4OUTPS3	T4OUTPS2	T4OUTPS1	T4OUTPS0	TMR4ON	T4CKPS1	T4CKPS0	-000 0000	36, 147		
CCPR4H	Capture/Compare/PWM Register 4 High Byte								xxxx xxxxx	36, 153		
CCPR4L	Capture/Compare/PWM Register 4 Low Byte								xxxx xxxxx	36, 153		
CCP4CON	—	—	DC4B1	DC4B0	CCP4M3	CCP4M2	CCP4M1	CCP4M0	--00 0000	36, 149		
CCPR5H	Capture/Compare/PWM Register 5 High Byte								xxxx xxxxx	36, 153		
CCPR5L	Capture/Compare/PWM Register 5 Low Byte								xxxx xxxxx	36, 153		
CCP5CON	—	—	DC5B1	DC5B0	CCP5M3	CCP5M2	CCP5M1	CCP5M0	--00 0000	36, 149		
SPBRG2	Enhanced USART2 Baud Rate Generator Register Low Byte								0000 0000	36, 217		
RCREG2	Enhanced USART2 Receive Register								0000 0000	36, 224		
TXREG2	Enhanced USART2 Transmit Register								0000 0000	36, 222		
TXSTA2	CSRC	TX9	TXEN	SYNC	SENDB	BRGH	TRMT	TX9D	0000 0010	36, 222		
RCSTA2	SPEN	RX9	SREN	CREN	ADDEN	FERR	OERR	RX9D	0000 000x	36, 222		
ECCP3AS	ECCP3ASE	ECCP3AS2	ECCP3AS1	ECCP3AS0	PSS3AC1	PSS3AC0	PSS3BD1	PSS3BD0	0000 0000	36, 169		
ECCP3DEL	P3RSEN	P3DC6	P3DC5	P3DC4	P3DC3	P3DC2	P3DC1	P3DC0	0000 0000	36, 168		
ECCP2AS	ECCP2ASE	ECCP2AS2	ECCP2AS1	ECCP2AS0	PSS2AC1	PSS2AC0	PSS2BD1	PSS2BD0	0000 0000	36, 169		
ECCP2DEL	P2RSEN	P2DC6	P2DC5	P2DC4	P2DC3	P2DC2	P2DC1	P2DC0	0000 0000	36, 168		

Legend: x = unknown, u = unchanged, — = unimplemented, q = value depends on condition

Note 1: RA6 and associated bits are configured as a port pin in RCIO and ECIO Oscillator modes only and read '0' in all other oscillator modes.

2: Bit 21 of the TBLPTRU allows access to the device configuration bits.

3: These registers are unused on PIC18F6525/6621 devices and read as '0'.

4: RG5 is available only if MCLR function is disabled in configuration.

5: Enabled only in Microcontroller mode for PIC18F8525/8621 devices.

4.10 Access Bank

The Access Bank is an architectural enhancement, which is very useful for C compiler code optimization. The techniques used by the C compiler may also be useful for programs written in assembly.

This data memory region can be used for:

- Intermediate computational values
- Local variables of subroutines
- Faster context saving/switching of variables
- Common variables
- Faster evaluation/control of SFRs (no banking)

The Access Bank is comprised of the upper 160 bytes in Bank 15 (SFRs) and the lower 96 bytes in Bank 0. These two sections will be referred to as Access RAM High and Access RAM Low, respectively. Figure 4-7 indicates the Access RAM areas.

A bit in the instruction word specifies if the operation is to occur in the bank specified by the BSR register or in the Access Bank. This bit is denoted by the 'a' bit (for access bit).

When forced in the Access Bank ($a = 0$), the last address in Access RAM Low is followed by the first address in Access RAM High. Access RAM High maps the Special Function Registers so that these registers can be accessed without any software overhead. This is useful for testing status flags and modifying control bits.

4.11 Bank Select Register (BSR)

The need for a large general purpose memory space dictates a RAM banking scheme. The data memory is partitioned into sixteen banks. When using direct addressing, the BSR should be configured for the desired bank.

BSR<3:0> holds the upper 4 bits of the 12-bit RAM address. The BSR<7:4> bits will always read '0's and writes will have no effect.

A `MOVLB` instruction has been provided in the instruction set to assist in selecting banks.

If the currently selected bank is not implemented, any read will return all '0's and all writes are ignored. The STATUS register bits will be set/cleared as appropriate for the instruction performed.

Each Bank extends up to FFh (256 bytes). All data memory is implemented as static RAM.

A `MOVFF` instruction ignores the BSR since the 12-bit addresses are embedded into the instruction word.

Section 4.12 "Indirect Addressing, INDF and FSR Registers" provides a description of indirect addressing which allows linear addressing of the entire RAM space.

FIGURE 4-8: DIRECT ADDRESSING

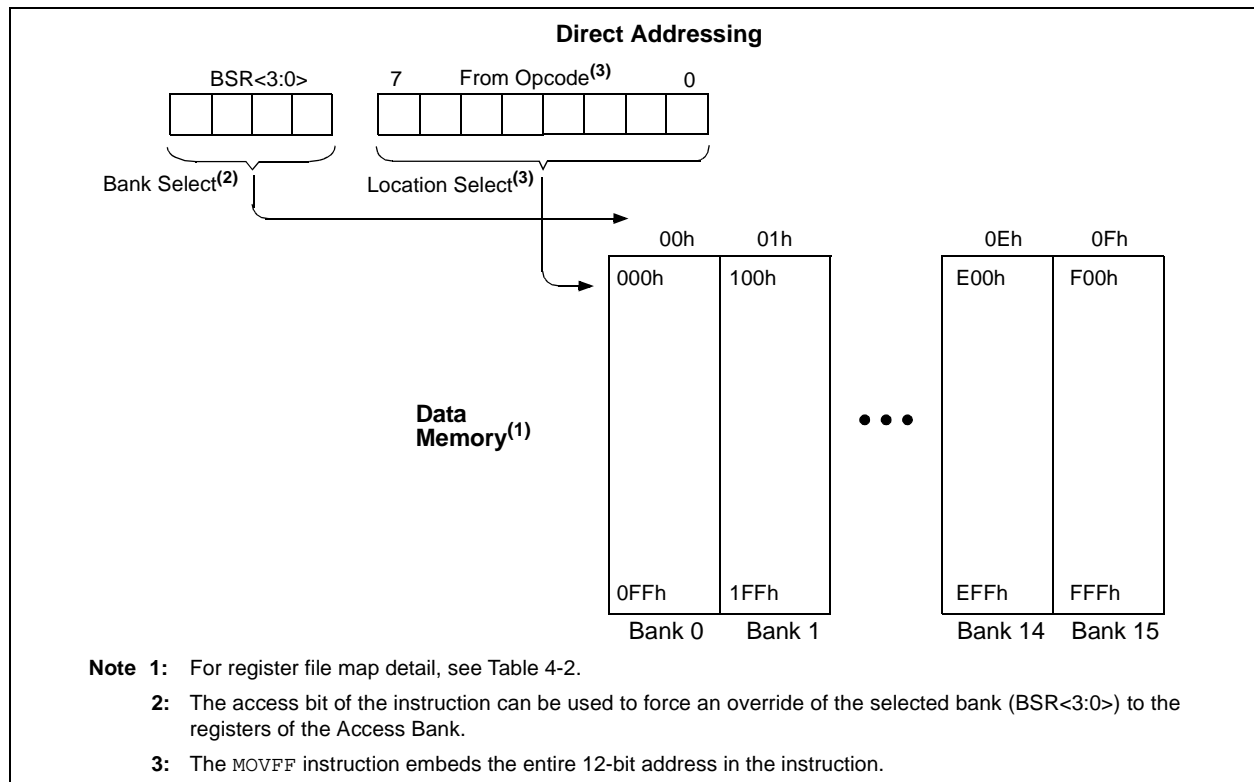

PIC18F6525/6621/8525/8621

4.12 Indirect Addressing, INDF and FSR Registers

Indirect addressing is a mode of addressing data memory, where the data memory address in the instruction is not fixed. An FSR register is used as a pointer to the data memory location that is to be read or written. Since this pointer is in RAM, the contents can be modified by the program. This can be useful for data tables in the data memory and for software stacks. Figure 4-9 shows the operation of indirect addressing. This shows the moving of the value to the data memory address specified by the value of the FSR register.

Indirect addressing is possible by using one of the INDF registers. Any instruction using the INDF register actually accesses the register pointed to by the File Select Register, FSR. Reading the INDF register indirectly (FSR = 0), will read 00h. Writing to the INDF register indirectly, results in a no operation (NOP). The FSR register contains a 12-bit address which is shown in Figure 4-10.

The INDFn register is not a physical register. Addressing INDFn actually addresses the register whose address is contained in the FSRn register (FSRn is a pointer). This is indirect addressing.

Example 4-5 shows a simple use of indirect addressing to clear the RAM in Bank 1 (locations 100h-1FFh) in a minimum number of instructions.

EXAMPLE 4-5: HOW TO CLEAR RAM (BANK 1) USING INDIRECT ADDRESSING

	LFSR	FSR0, 0x100	;
NEXT	CLRF	POSTINC0	; Clear INDF
			; register and
			; inc pointer
	BTFSS	FSR0H, 1	; All done with
			; Bank1?
	GOTO	NEXT	; NO, clear next
CONTINUE			; YES, continue

There are three indirect addressing registers. To address the entire data memory space (4096 bytes), these registers are 12 bits wide. To store the 12 bits of addressing information, two 8-bit registers are required. These indirect addressing registers are:

1. FSR0: composed of FSR0H:FSR0L
2. FSR1: composed of FSR1H:FSR1L
3. FSR2: composed of FSR2H:FSR2L

In addition, there are registers INDF0, INDF1 and INDF2, which are not physically implemented. Reading or writing to these registers activates indirect addressing, with the value in the corresponding FSR register being the address of the data. If an instruction writes a value to INDF0, the value will be written to the address pointed to by FSR0H:FSR0L. A read from INDF1 reads

the data from the address pointed to by FSR1H:FSR1L. INDFn can be used in code anywhere an operand can be used.

If INDF0, INDF1 or INDF2 are read indirectly via an FSR, all '0's are read (zero bit is set). Similarly, if INDF0, INDF1 or INDF2 are written to indirectly, the operation will be equivalent to a NOP instruction and the Status bits are not affected.

4.12.1 INDIRECT ADDRESSING OPERATION

Each FSR register has an INDF register associated with it, plus four additional register addresses. Performing an operation on one of these five registers determines how the FSR will be modified during indirect addressing.

When data access is done to one of the five INDFn locations, the address selected will configure the FSRn register to:

- Do nothing to FSRn after an indirect access (no change) – INDFn.
- Auto-decrement FSRn after an indirect access (post-decrement) – POSTDECn.
- Auto-increment FSRn after an indirect access (post-increment) – POSTINCn.
- Auto-increment FSRn before an indirect access (pre-increment) – PREINCn.
- Use the value in the WREG register as an offset to FSRn. Do not modify the value of the WREG or the FSRn register after an indirect access (no change) – PLUSWn.

When using the auto-increment or auto-decrement features, the effect on the FSR is not reflected in the STATUS register. For example, if the indirect address causes the FSR to equal '0', the Z bit will not be set.

Incrementing or decrementing an FSR affects all 12 bits. That is, when FSRnL overflows from an increment, FSRnH will be incremented automatically.

Adding these features allows the FSRn to be used as a Stack Pointer in addition to its uses for table operations in data memory.

Each FSR has an address associated with it that performs an indexed indirect access. When a data access to this INDFn location (PLUSWn) occurs, the FSRn is configured to add the signed value in the WREG register and the value in FSR to form the address before an indirect access. The FSR value is not changed.

If an FSR register contains a value that points to one of the INDFn, an indirect read will read 00h (zero bit is set), while an indirect write will be equivalent to a NOP (Status bits are not affected).

If an indirect addressing operation is done where the target address is an FSRnH or FSRnL register, the write operation will dominate over the pre- or post-increment/decrement functions.

FIGURE 4-9: INDIRECT ADDRESSING OPERATION

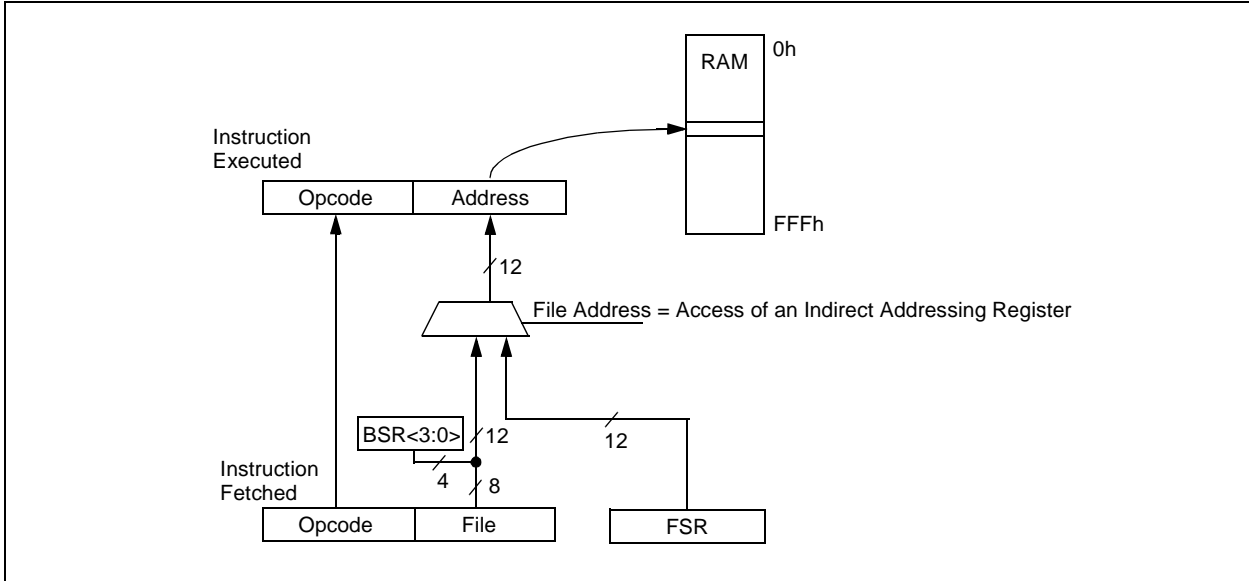
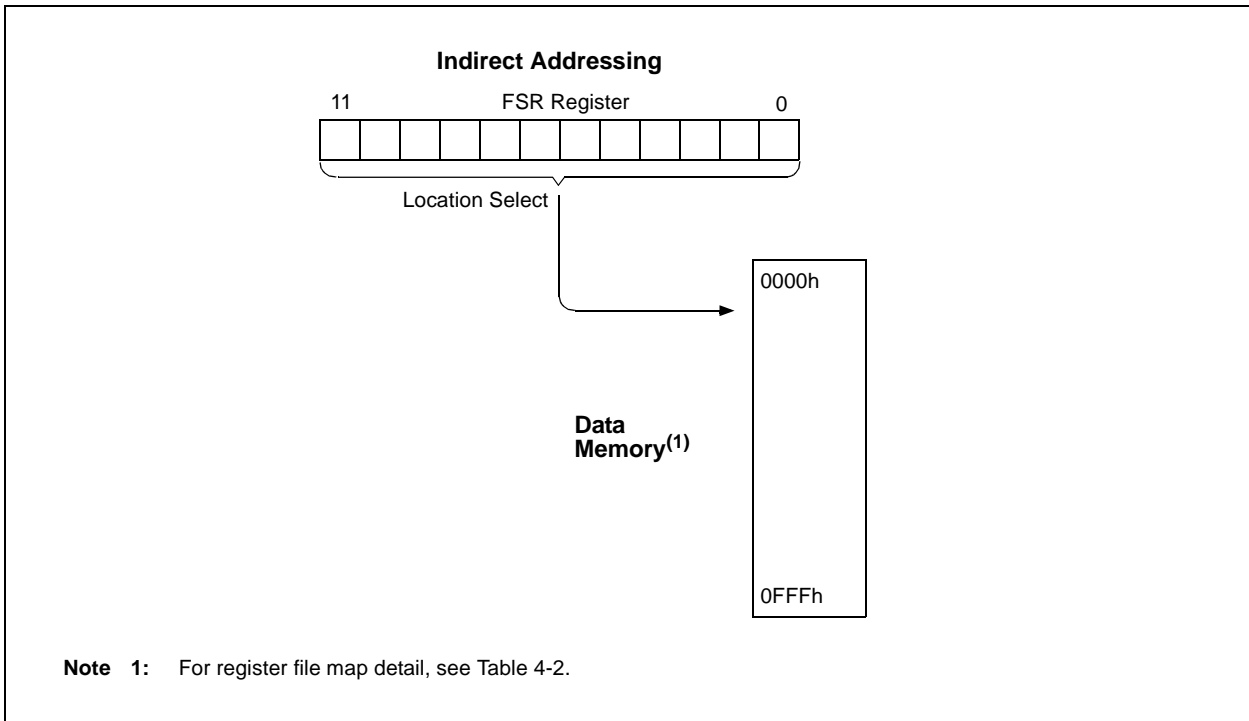

FIGURE 4-10: INDIRECT ADDRESSING



PIC18F6525/6621/8525/8621

4.13 STATUS Register

The STATUS register, shown in Register 4-3, contains the arithmetic status of the ALU. As with any other SFR, it can be the operand for any instruction.

If the STATUS register is the destination for an instruction that affects the Z, DC, C, OV or N bits, the results of the instruction are not written; instead, the status is updated according to the instruction performed. Therefore, the result of an instruction with the STATUS register as its destination may be different than intended. As an example, `CLRF STATUS` will set the Z bit and leave the remaining Status bits unchanged ('000u u1uu').

It is recommended that only `BCF`, `BSF`, `SWAPF`, `MOVFF` and `MOVWF` instructions are used to alter the STATUS register, because these instructions do not affect the Z, C, DC, OV or N bits in the STATUS register.

For other instructions that do not affect Status bits, see the instruction set summaries in Table 25-2.

Note: The C and DC bits operate as the borrow and digit borrow bits respectively in subtraction.

REGISTER 4-3: STATUS REGISTER

U-0	U-0	U-0	R/W-x	R/W-x	R/W-x	R/W-x	R/W-x	
—	—	—	N	OV	Z	DC	C	
bit 7								bit 0

- bit 7-5 **Unimplemented:** Read as '0'
- bit 4 **N:** Negative bit
This bit is used for signed arithmetic (2's complement). It indicates whether the result was negative (ALU MSB = 1).
1 = Result was negative
0 = Result was positive
- bit 3 **OV:** Overflow bit
This bit is used for signed arithmetic (2's complement). It indicates an overflow of the 7-bit magnitude which causes the sign bit (bit 7) to change state.
1 = Overflow occurred for signed arithmetic (in this arithmetic operation)
0 = No overflow occurred
- bit 2 **Z:** Zero bit
1 = The result of an arithmetic or logic operation is zero
0 = The result of an arithmetic or logic operation is not zero
- bit 1 **DC:** Digit Carry/Borrow bit
For `ADDWF`, `ADDLW`, `SUBLW` and `SUBWF` instructions:
1 = A carry-out from the 4th low-order bit of the result occurred
0 = No carry-out from the 4th low-order bit of the result
Note: For borrow, the polarity is reversed. A subtraction is executed by adding the 2's complement of the second operand. For rotate (`RRF`, `RLF`) instructions, this bit is loaded with either bit 4 or bit 3 of the source register.
- bit 0 **C:** Carry/Borrow bit
For `ADDWF`, `ADDLW`, `SUBLW` and `SUBWF` instructions:
1 = A carry-out from the Most Significant bit of the result occurred
0 = No carry-out from the Most Significant bit of the result occurred
Note: For borrow, the polarity is reversed. A subtraction is executed by adding the 2's complement of the second operand. For rotate (`RRF`, `RLF`) instructions, this bit is loaded with either the high- or low-order bit of the source register.

Legend:

R = Readable bit	W = Writable bit	U = Unimplemented bit, read as '0'
-n = Value at POR	'1' = Bit is set	'0' = Bit is cleared x = Bit is unknown

PIC18F6525/6621/8525/8621

4.14 RCON Register

The Reset Control (RCON) register contains flag bits that allow differentiation between the sources of a device Reset. These flags include the $\overline{\text{TO}}$, $\overline{\text{PD}}$, $\overline{\text{POR}}$, $\overline{\text{BOR}}$ and $\overline{\text{RI}}$ bits. This register is readable and writable.

Note: It is recommended that the $\overline{\text{POR}}$ bit be set after a Power-on Reset has been detected, so that subsequent Power-on Resets may be detected.

REGISTER 4-4: RCON: RESET CONTROL REGISTER

R/W-0	U-0	U-0	R/W-1	R/W-1	R/W-1	R/W-0	R/W-0
IPEN	—	—	$\overline{\text{RI}}$	$\overline{\text{TO}}$	$\overline{\text{PD}}$	$\overline{\text{POR}}$	$\overline{\text{BOR}}$
bit 7							bit 0

- bit 7 **IPEN:** Interrupt Priority Enable bit
 1 = Enable priority levels on interrupts
 0 = Disable priority levels on interrupts (PIC16CXXX Compatibility mode)
- bit 6-5 **Unimplemented:** Read as '0'
- bit 4 **$\overline{\text{RI}}$:** RESET Instruction Flag bit
 1 = The RESET instruction was not executed
 0 = The RESET instruction was executed causing a device Reset (must be set in software after a Brown-out Reset occurs)
- bit 3 **$\overline{\text{TO}}$:** Watchdog Time-out Flag bit
 1 = After power-up, CLRWD $\overline{\text{T}}$ instruction or SLEEP instruction
 0 = A WDT time-out occurred
- bit 2 **$\overline{\text{PD}}$:** Power-down Detection Flag bit
 1 = After power-up or by the CLRWD $\overline{\text{T}}$ instruction
 0 = By execution of the SLEEP instruction
- bit 1 **$\overline{\text{POR}}$:** Power-on Reset Status bit
 1 = A Power-on Reset has not occurred
 0 = A Power-on Reset occurred (must be set in software after a Power-on Reset occurs)
- bit 0 **$\overline{\text{BOR}}$:** Brown-out Reset Status bit
 1 = A Brown-out Reset has not occurred
 0 = A Brown-out Reset occurred (must be set in software after a Brown-out Reset occurs)

Legend:

R = Readable bit	W = Writable bit	U = Unimplemented bit, read as '0'
-n = Value at POR	'1' = Bit is set	'0' = Bit is cleared x = Bit is unknown

PIC18F6525/6621/8525/8621

NOTES:

5.0 FLASH PROGRAM MEMORY

The Flash program memory is readable, writable and erasable, during normal operation over the entire VDD range.

A read from program memory is executed on one byte at a time. A write to program memory is executed on blocks of 8 bytes at a time. Program memory is erased in blocks of 64 bytes at a time. A bulk erase operation may not be issued from user code.

Writing or erasing program memory will cease instruction fetches until the operation is complete. The program memory cannot be accessed during the write or erase, therefore, code cannot execute. An internal programming timer terminates program memory writes and erases.

A value written to program memory does not need to be a valid instruction. Executing a program memory location that forms an invalid instruction results in a NOP.

5.1 Table Reads and Table Writes

In order to read and write program memory, there are two operations that allow the processor to move bytes between the program memory space and the data RAM:

- Table Read (TBLRD)
- Table Write (TBLWT)

The program memory space is 16 bits wide, while the data RAM space is 8 bits wide. Table reads and table writes move data between these two memory spaces through an 8-bit register (TABLAT).

Table read operations retrieve data from program memory and place it into the data RAM space. Figure 5-1 shows the operation of a table read with program memory and data RAM.

Table write operations store data from the data memory space into holding registers in program memory. The procedure to write the contents of the holding registers into program memory is detailed in **Section 5.5 “Writing to Flash Program Memory”**. Figure 5-2 shows the operation of a table write with program memory and data RAM.

Table operations work with byte entities. A table block containing data, rather than program instructions, is not required to be word aligned. Therefore, a table block can start and end at any byte address. If a table write is being used to write executable code into program memory, program instructions will need to be word aligned.

FIGURE 5-1: TABLE READ OPERATION

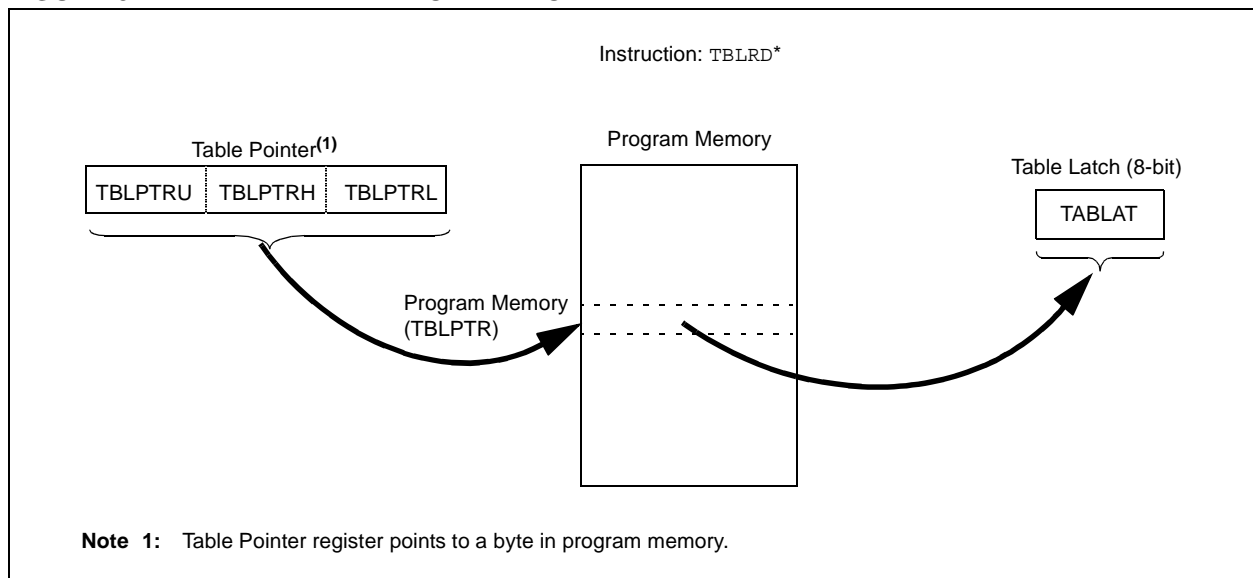

PIC18F6525/6621/8525/8621

FIGURE 5-2: TABLE WRITE OPERATION

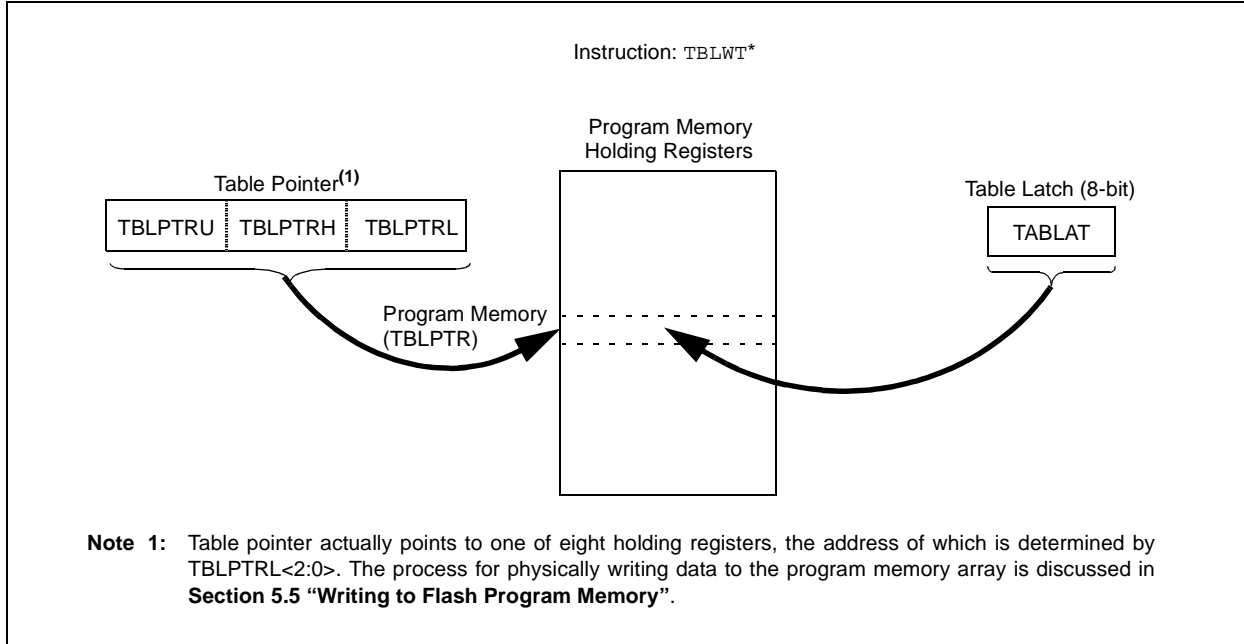

5.2 Control Registers

Several control registers are used in conjunction with the TBLRD and TBLWT instructions. These include the:

- EECON1 register
- EECON2 register
- TABLAT register
- TBLPTR registers

5.2.1 EECON1 AND EECON2 REGISTERS

EECON1 is the control register for memory accesses.

EECON2 is not a physical register. Reading EECON2 will read all '0's. The EECON2 register is used exclusively in the memory write and erase sequences.

Control bit, EEPGD, determines if the access will be a program or data EEPROM memory access. When clear, any subsequent operations will operate on the data EEPROM memory. When set, any subsequent operations will operate on the program memory.

Control bit, CFGS, determines if the access will be to the Configuration/Calibration registers or to program memory/data EEPROM memory. When set, subsequent operations will operate on Configuration registers regardless of EEPGD (see Section 24.0 “Special Features of the CPU”). When clear, memory selection access is determined by EEPGD.

The FREE bit, when set, will allow a program memory erase operation. When the FREE bit is set, the erase operation is initiated on the next WR command. When FREE is clear, only writes are enabled.

The WREN bit, when set, will allow a write operation. On power-up, the WREN bit is clear. The WRERR bit is set when a write operation is interrupted by a MCLR Reset or a WDT Time-out Reset during normal operation. In these situations, the user can check the WRERR bit and rewrite the location. It is necessary to reload the data and address registers (EEDATA and EEDADR) due to Reset values of zero.

Note: During normal operation, the WRERR bit is read as '1'. This can indicate that a write operation was prematurely terminated by a Reset, or a write operation was attempted improperly.

The WR control bit initiates write operations. The bit cannot be cleared, only set, in software; it is cleared in hardware at the completion of the write operation. The inability to clear the WR bit in software prevents the accidental or premature termination of a write operation.

Note: Interrupt flag bit, EEIF in the PIR2 register, is set when the write is complete. It must be cleared in software.

PIC18F6525/6621/8525/8621

REGISTER 5-1: EECON1 REGISTER (ADDRESS FA6h)

R/W-x	R/W-x	U-0	R/W-0	R/W-x	R/W-0	R/S-0	R/S-0
EEPGD	CFGS	—	FREE	WRERR	WREN	WR	RD
bit 7						bit 0	

- bit 7 **EEPGD:** Flash Program or Data EEPROM Memory Select bit
 1 = Access Flash program memory
 0 = Access data EEPROM memory
- bit 6 **CFGS:** Flash Program/Data EEPROM or Configuration Select bit
 1 = Access Configuration registers
 0 = Access Flash program or data EEPROM memory
- bit 5 **Unimplemented:** Read as '0'
- bit 4 **FREE:** Flash Row Erase Enable bit
 1 = Erase the program memory row addressed by TBLPTR on the next WR command
 (cleared by completion of erase operation)
 0 = Perform write only
- bit 3 **WRERR:** Flash Program/Data EEPROM Error Flag bit
 1 = A write operation is prematurely terminated
 (any Reset during self-timed programming in normal operation)
 0 = The write operation completed
Note: When a WRERR occurs, the EEGPD and CFGS bits are not cleared. This allows tracing of the error condition.
- bit 2 **WREN:** Flash Program/Data EEPROM Write Enable bit
 1 = Allows write cycles to Flash program/data EEPROM
 0 = Inhibits write cycles to Flash program/data EEPROM
- bit 1 **WR:** Write Control bit
 1 = Initiates a data EEPROM erase/write cycle or a program memory erase cycle or write cycle.
 (The operation is self-timed and the bit is cleared by hardware once write is complete. The WR bit can only be set (not cleared) in software.)
 0 = Write cycle to the EEPROM is complete
- bit 0 **RD:** Read Control bit
 1 = Initiates an EEPROM read
 (Read takes one cycle. RD is cleared in hardware. The RD bit can only be set (not cleared) in software. RD bit cannot be set when EEGPD = 1.)
 0 = Does not initiate an EEPROM read

Legend:

R = Readable bit	W = Writable bit	U = Unimplemented bit, read as '0'
-n = Value at POR	'1' = Bit is set	'0' = Bit is cleared x = Bit is unknown

PIC18F6525/6621/8525/8621

5.2.2 TABLAT – TABLE LATCH REGISTER

The Table Latch (TABLAT) is an 8-bit register mapped into the SFR space. The Table Latch register is used to hold 8-bit data during data transfers between program memory and data RAM.

5.2.3 TBLPTR – TABLE POINTER REGISTER

The Table Pointer register (TBLPTR) addresses a byte within the program memory. The TBLPTR is comprised of three SFR registers: Table Pointer Upper Byte, Table Pointer High Byte and Table Pointer Low Byte (TBLPTRU:TBLPTRH:TBLPTRL). These three registers join to form a 22-bit wide pointer. The low-order 21 bits allow the device to address up to 2 Mbytes of program memory space. The 22nd bit allows access to the device ID, the user ID and the configuration bits.

The Table Pointer, TBLPTR, is used by the TBLRD and TBLWT instructions. These instructions can update the TBLPTR in one of four ways based on the table operation. These operations are shown in Table 5-1. These operations on the TBLPTR only affect the low-order 21 bits.

5.2.4 TABLE POINTER BOUNDARIES

TBLPTR is used in reads, writes and erases of the Flash program memory.

When a TBLRD is executed, all 22 bits of the TBLPTR determine which byte is read from program memory into TABLAT.

When a TBLWT is executed, the three LSBs of the Table Pointer register (TBLPTR<2:0>) determine which of the eight program memory holding registers is written to. When the timed write to program memory (long write) begins, the 19 MSBs of the TBLPTR (TBLPTR<21:3>) will determine which program memory block of 8 bytes is written to. For more detail, see **Section 5.5 “Writing to Flash Program Memory”**.

When an erase of program memory is executed, the 16 MSBs of the Table Pointer register (TBLPTR<21:6>) point to the 64-byte block that will be erased. The Least Significant bits (TBLPTR<5:0>) are ignored.

Figure 5-3 describes the relevant boundaries of TBLPTR based on Flash program memory operations.

TABLE 5-1: TABLE POINTER OPERATIONS WITH TBLRD AND TBLWT INSTRUCTIONS

Example	Operation on Table Pointer
TBLRD* TBLWT*	TBLPTR is not modified
TBLRD** TBLWT**	TBLPTR is incremented after the read/write
TBLRD*- TBLWT*-	TBLPTR is decremented after the read/write
TBLRD+* TBLWT+*	TBLPTR is incremented before the read/write

FIGURE 5-3: TABLE POINTER BOUNDARIES BASED ON OPERATION

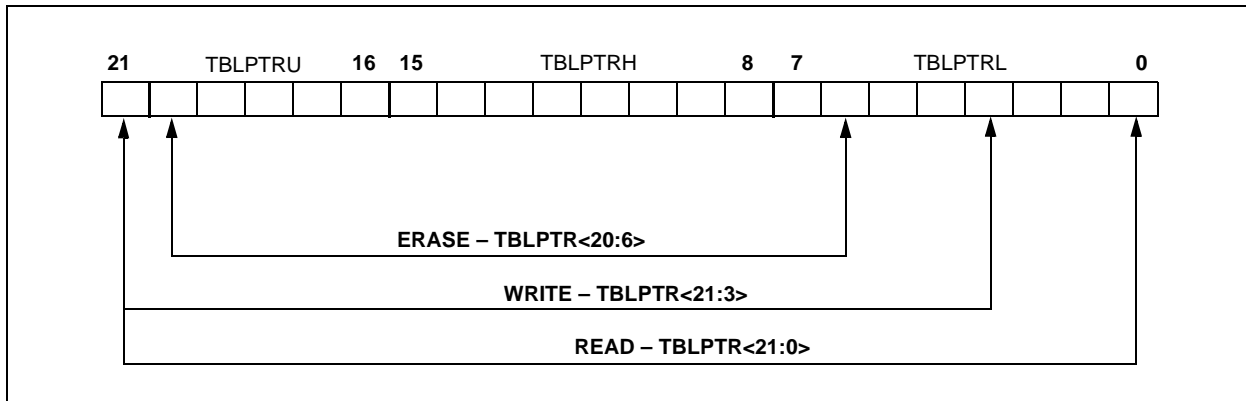

5.3 Reading the Flash Program Memory

The `TBLRD` instruction is used to retrieve data from program memory and places it into data RAM. Table reads from program memory are performed one byte at a time.

`TBLPTR` points to a byte address in program space. Executing `TBLRD` places the byte pointed to into `TABLAT`. In addition, `TBLPTR` can be modified automatically for the next table read operation.

The internal program memory is typically organized by words. The Least Significant bit of the address selects between the high and low bytes of the word. Figure 5-4 shows the interface between the internal program memory and the `TABLAT`.

FIGURE 5-4: READS FROM FLASH PROGRAM MEMORY

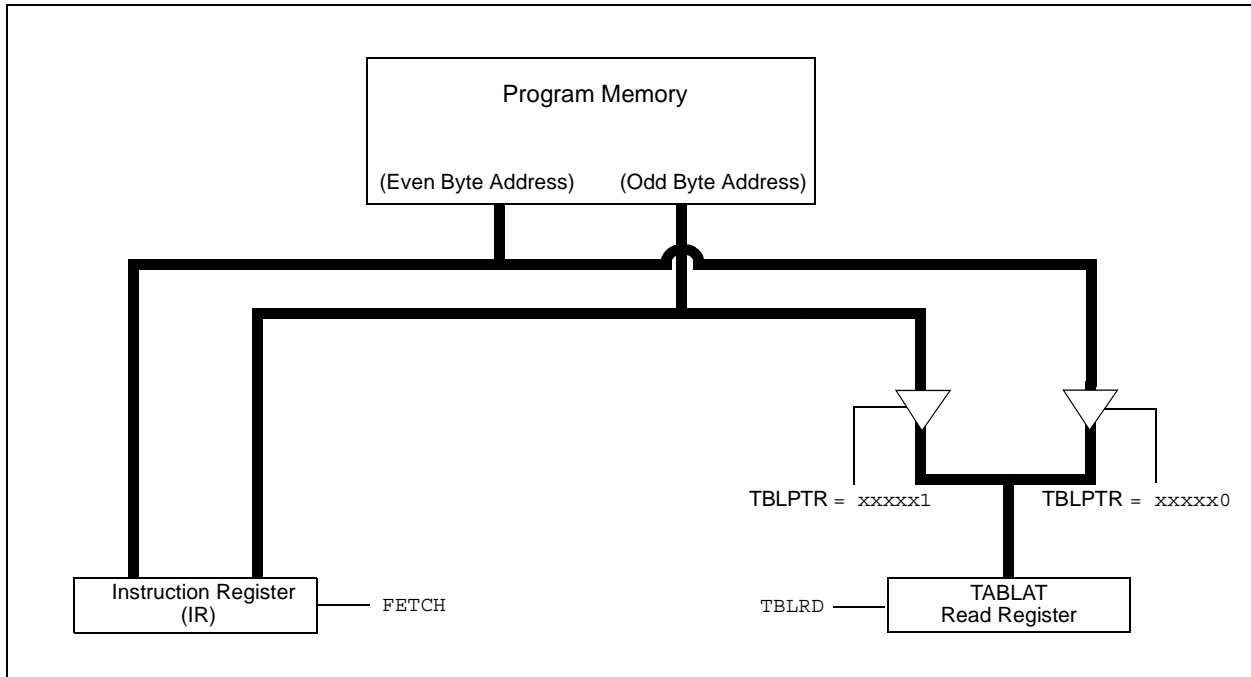

EXAMPLE 5-1: READING A FLASH PROGRAM MEMORY WORD

```

        MOVLW    CODE_ADDR_UPPER      ; Load TBLPTR with the base
        MOVWF   TBLPTRU                ; address of the word
        MOVLW    CODE_ADDR_HIGH
        MOVWF   TBLPTRH
        MOVLW    CODE_ADDR_LOW
        MOVWF   TBLPTRL
READ_WORD
        TBLRD*+                          ; read into TABLAT and increment
        MOVF    TABLAT, W                ; get data
        MOVWF   WORD_EVEN
        TBLRD*+                          ; read into TABLAT and increment
        MOVFW   TABLAT, W                ; get data
        MOVWF   WORD_ODD
    
```

PIC18F6525/6621/8525/8621

5.4 Erasing Flash Program Memory

The minimum erase block is 32 words or 64 bytes. Only through the use of an external programmer, or through ICSP control, can larger blocks of program memory be bulk erased. Word erase in the Flash array is not supported.

When initiating an erase sequence from the microcontroller itself, a block of 64 bytes of program memory is erased. The Most Significant 16 bits of the TBLPTR<21:6> point to the block being erased. TBLPTR<5:0> are ignored.

The EECON1 register commands the erase operation. The EEPGD bit must be set to point to the Flash program memory. The WREN bit must be set to enable write operations. The FREE bit is set to select an erase operation.

For protection, the write initiate sequence for EECON2 must be used.

A long write is necessary for erasing the internal Flash. Instruction execution is halted while in a long write cycle. The long write will be terminated by the internal programming timer.

5.4.1 FLASH PROGRAM MEMORY ERASE SEQUENCE

The sequence of events for erasing a block of internal program memory location is:

1. Load Table Pointer register with address of row being erased.
2. Set the EECON1 register for the erase operation:
 - set EEPGD bit to point to program memory;
 - clear the CFGS bit to access program memory;
 - set WREN bit to enable writes;
 - set FREE bit to enable the erase.
3. Disable interrupts.
4. Write 55h to EECON2.
5. Write AAh to EECON2.
6. Set the WR bit. This will begin the row erase cycle.
7. The CPU will stall for duration of the erase (about 2 ms using internal timer).
8. Re-enable interrupts.

EXAMPLE 5-2: ERASING A FLASH PROGRAM MEMORY ROW

	MOVLW	CODE_ADDR_UPPER	; load TBLPTR with the base
	MOVWF	TBLPTRU	; address of the memory block
	MOVLW	CODE_ADDR_HIGH	
	MOVWF	TBLPTRH	
	MOVLW	CODE_ADDR_LOW	
	MOVWF	TBLPTRL	
ERASE_ROW	BSF	EECON1, EEPGD	; point to Flash program memory
	BCF	EECON1, CFGS	; access Flash program memory
	BSF	EECON1, WREN	; enable write to memory
	BSF	EECON1, FREE	; enable Row Erase operation
	BCF	INTCON, GIE	; disable interrupts
	MOVLW	55h	
Required	MOVWF	EECON2	; write 55h
Sequence	MOVLW	AAh	
	MOVWF	EECON2	; write AAh
	BSF	EECON1, WR	; start erase (CPU stall)
	BSF	INTCON, GIE	; re-enable interrupts

5.5 Writing to Flash Program Memory

The minimum programming block is 4 words or 8 bytes. Word or byte programming is not supported.

Table writes are used internally to load the holding registers needed to program the Flash memory. There are 8 holding registers used by the table writes for programming.

Since the Table Latch (TABLAT) is only a single byte, the TBLWT instruction has to be executed 8 times for each programming operation. All of the table write operations will essentially be short writes because only

the holding registers are written. At the end of updating 8 registers, the EECON1 register must be written to, to start the programming operation with a long write.

The long write is necessary for programming the internal Flash. Instruction execution is halted while in a long write cycle. The long write will be terminated by the internal programming timer.

The EEPROM on-chip timer controls the write time. The write/erase voltages are generated by an on-chip charge pump, rated to operate over the voltage range of the device for byte or word operations.

FIGURE 5-5: TABLE WRITES TO FLASH PROGRAM MEMORY

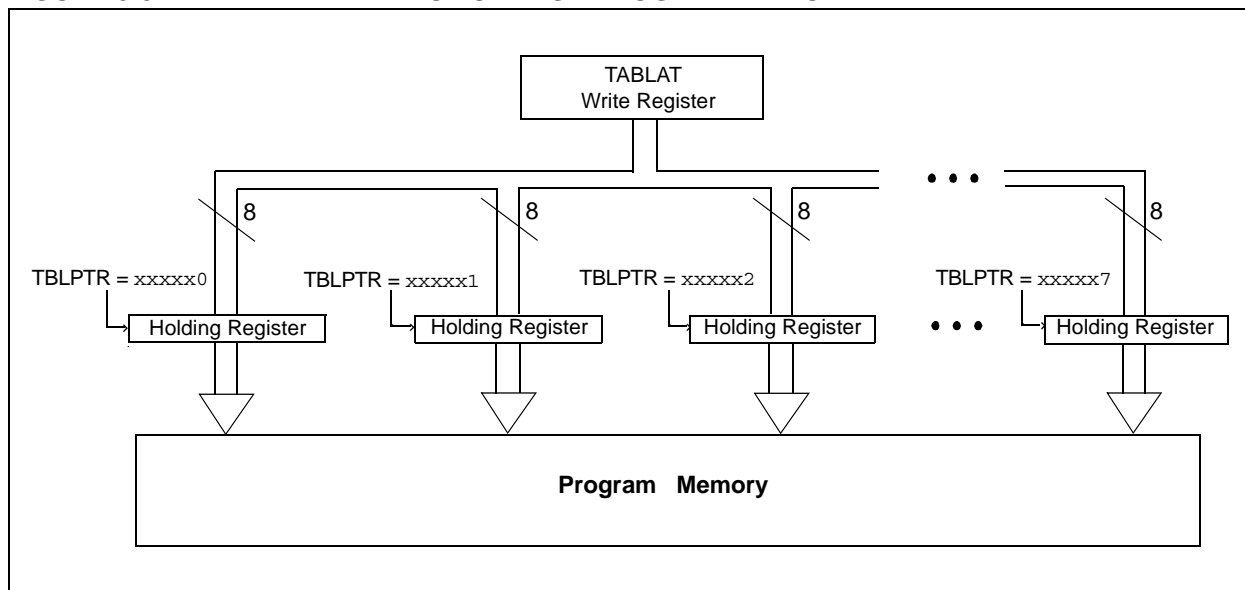

5.5.1 FLASH PROGRAM MEMORY WRITE SEQUENCE

The sequence of events for programming an internal program memory location should be:

1. Read 64 bytes into RAM.
2. Update data values in RAM as necessary.
3. Load Table Pointer register with address being erased.
4. Do the row erase procedure.
5. Load Table Pointer register with address of first byte being written.
6. Write the first 8 bytes into the holding registers with auto-increment.
7. Set the EECON1 register for the write operation:
 - set EEPGD bit to point to program memory;
 - clear the CFGS bit to access program memory;
 - set WREN to enable byte writes.

8. Disable interrupts.
9. Write 55h to EECON2.
10. Write AAh to EECON2.
11. Set the WR bit. This will begin the write cycle.
12. The CPU will stall for duration of the write (about 2 ms using internal timer).
13. Re-enable interrupts.
14. Repeat steps 6-14 seven times to write 64 bytes.
15. Verify the memory (table read).

This procedure will require about 18 ms to update one row of 64 bytes of memory. An example of the required code is given in Example 5-3.

Note: Before setting the WR bit, the Table Pointer address needs to be within the intended address range of the eight bytes in the holding register.

PIC18F6525/6621/8525/8621

EXAMPLE 5-3: WRITING TO FLASH PROGRAM MEMORY

```
        MOVLW    D'64                ; number of bytes in erase block
        MOVWF    COUNTER
        MOVLW    BUFFER_ADDR_HIGH    ; point to buffer
        MOVWF    FSR0H
        MOVLW    BUFFER_ADDR_LOW
        MOVWF    FSR0L
        MOVLW    CODE_ADDR_UPPER     ; Load TBLPTR with the base
        MOVWF    TBLPTRU             ; address of the memory block
        MOVLW    CODE_ADDR_HIGH
        MOVWF    TBLPTRH
        MOVLW    CODE_ADDR_LOW
        MOVWF    TBLPTRL

READ_BLOCK
        TBLRD*+                       ; read into TABLAT, and inc
        MOVF     TABLAT, W             ; get data
        MOVWF    POSTINC0            ; store data
        DECFSZ   COUNTER              ; done?
        BRA     READ_BLOCK            ; repeat

MODIFY_WORD
        MOVLW    DATA_ADDR_HIGH     ; point to buffer
        MOVWF    FSR0H
        MOVLW    DATA_ADDR_LOW
        MOVWF    FSR0L
        MOVLW    NEW_DATA_LOW        ; update buffer word
        MOVWF    POSTINC0
        MOVLW    NEW_DATA_HIGH
        MOVWF    INDF0

ERASE_BLOCK
        MOVLW    CODE_ADDR_UPPER     ; load TBLPTR with the base
        MOVWF    TBLPTRU             ; address of the memory block
        MOVLW    CODE_ADDR_HIGH
        MOVWF    TBLPTRH
        MOVLW    CODE_ADDR_LOW
        MOVWF    TBLPTRL
        BSF     EECON1, EEPGD        ; point to Flash program memory
        BCF     EECON1, CFGS         ; access Flash program memory
        BSF     EECON1, WREN         ; enable write to memory
        BSF     EECON1, FREE        ; enable Row Erase operation
        BCF     INTCON, GIE         ; disable interrupts

Required
Sequence
        MOVLW    55h
        MOVWF    EECON2              ; write 55h
        MOVLW    AAh
        MOVWF    EECON2              ; write AAh
        BSF     EECON1, WR           ; start erase (CPU stall)
        BSF     INTCON, GIE         ; re-enable interrupts
        TBLRD*-                       ; dummy read decrement

WRITE_BUFFER_BACK
        MOVLW    8                   ; number of write buffer groups of 8 bytes
        MOVWF    COUNTER_HI
        MOVLW    BUFFER_ADDR_HIGH    ; point to buffer
        MOVWF    FSR0H
        MOVLW    BUFFER_ADDR_LOW
        MOVWF    FSR0L

PROGRAM_LOOP
        MOVLW    8                   ; number of bytes in holding register
        MOVWF    COUNTER

WRITE_WORD_TO_HREGS
        MOVFF   POSTINC0, WREG       ; get low byte of buffer data
        ; present data to table latch
        TBLWT*+                       ; write data, perform a short write
        ; to internal TBLWT holding register.
        DECFSZ  COUNTER              ; loop until buffers are full
        BRA     WRITE_WORD_TO_HREGS
```

PIC18F6525/6621/8525/8621

EXAMPLE 5-3: WRITING TO FLASH PROGRAM MEMORY (CONTINUED)

PROGRAM_MEMORY										
	BSF	EECON1, EEPGD								; point to Flash program memory
	BCF	EECON1, CFGS								; access Flash program memory
	BSF	EECON1, WREN								; enable write to memory
	BCF	INTCON, GIE								; disable interrupts
	MOVLW	55h								
Required Sequence	MOVWF	EECON2								; write 55h
	MOVLW	AAh								
	MOVWF	EECON2								; write AAh
	BSF	EECON1, WR								; start program (CPU stall)
	BSF	INTCON, GIE								; re-enable interrupts
	DECFSZ	COUNTER_HI								; loop until done
	BRA	PROGRAM_LOOP								
	BCF	EECON1, WREN								; disable write to memory

5.5.2 WRITE VERIFY

Depending on the application, good programming practice may dictate that the value written to the memory should be verified against the original value. This should be used in applications where excessive writes can stress bits near the specification limit.

5.5.3 UNEXPECTED TERMINATION OF WRITE OPERATION

If a write is terminated by an unplanned event, such as loss of power or an unexpected Reset, the memory location just programmed should be verified and reprogrammed if needed. The WRERR bit is set when a write operation is interrupted by a MCLR Reset or a WDT Time-out Reset during normal operation. In these situations, users can check the WRERR bit and rewrite the location.

5.5.4 PROTECTION AGAINST SPURIOUS WRITES

To protect against spurious writes to Flash program memory, the write initiate sequence must also be followed. See Section 24.0 “Special Features of the CPU” for more detail.

5.6 Flash Program Operation During Code Protection

See Section 24.0 “Special Features of the CPU” for details on code protection of Flash program memory.

TABLE 5-2: REGISTERS ASSOCIATED WITH PROGRAM FLASH MEMORY

Name	Bit 7	Bit 6	Bit 5	Bit 4	Bit 3	Bit 2	Bit 1	Bit 0	Value on: POR, BOR	Value on all other Resets
TBLPTRU	—	—	bit 21 ⁽¹⁾	Program Memory Table Pointer Upper Byte (TBLPTR<20:16>)					--00 0000	--00 0000
TBLPTRH	Program Memory Table Pointer High Byte (TBLPTR<15:8>)								0000 0000	0000 0000
TBLPTRL	Program Memory Table Pointer Low Byte (TBLPTR<7:0>)								0000 0000	0000 0000
TABLAT	Program Memory Table Latch								0000 0000	0000 0000
INTCON	GIE/GIEH	PEIE/GIEL	TMR0IE	INT0IE	RBIE	TMR0IF	INT0IF	RBIF	0000 000x	0000 000u
EECON2	EEPROM Control Register 2 (not a physical register)								—	—
EECON1	EEPGD	CFGFS	—	FREE	WRERR	WREN	WR	RD	xx-0 x000	uu-0 u000
IPR2	—	CMIP	—	EEIP	BCLIP	LVDIP	TMR3IP	CCP2IP	-1-1 1111	-1-1 1111
PIR2	—	CMIF	—	EEIF	BCLIF	LVDIF	TMR3IF	CCP2IF	-0-0 0000	-0-0 0000
PIE2	—	CMIE	—	EEIE	BCLIE	LVDIE	TMR3IE	CCP2IE	-0-0 0000	-0-0 0000

Legend: x = unknown, u = unchanged, r = reserved, — = unimplemented, read as '0'.
Shaded cells are not used during Flash/EEPROM access.

Note 1: Bit 21 of the TBLPTRU allows access to device configuration bits.

PIC18F6525/6621/8525/8621

NOTES:

PIC18F6525/6621/8525/8621

6.0 EXTERNAL MEMORY INTERFACE

Note: The external memory interface is not implemented on PIC18F6525/6621 (64-pin) devices.

The external memory interface is a feature of the PIC18F8525/8621 devices that allows the controller to access external memory devices (such as Flash, EPROM, SRAM, etc.) as program or data memory.

The physical implementation of the interface uses 27 pins. These pins are reserved for external address/data bus functions; they are multiplexed with I/O port pins on four ports. Three I/O ports are multiplexed with the address/data bus, while the fourth port is multiplexed with the bus control signals. The I/O port functions are enabled when the EBDIS bit in the MEMCON register is set (see Register 6-1). A list of the multiplexed pins and their functions is provided in Table 6-1.

As implemented in the PIC18F8525/8621 devices, the interface operates in a similar manner to the external memory interface introduced on PIC18C601/801 microcontrollers. The most notable difference is that the interface on PIC18F8525/8621 devices only operates in 16-bit modes. The 8-bit mode is not supported.

For a more complete discussion of the operating modes that use the external memory interface, refer to Section 4.1.1 “PIC18F6525/6621/8525/8621 Program Memory Modes”.

6.1 Program Memory Modes and the External Memory Interface

As previously noted, PIC18F8525/8621 controllers are capable of operating in any one of four program memory modes using combinations of on-chip and external program memory. The functions of the multiplexed port pins depends on the program memory mode selected, as well as the setting of the EBDIS bit.

In **Microprocessor Mode**, the external bus is always active and the port pins have only the external bus function.

In **Microcontroller Mode**, the bus is not active and the pins have their port functions only. Writes to the MEMCOM register are not permitted.

In **Microprocessor with Boot Block** or **Extended Microcontroller Mode**, the external program memory bus shares I/O port functions on the pins. When the device is fetching or doing table read/table write operations on the external program memory space, the pins will have the external bus function. If the device is fetching and accessing internal program memory locations only, the EBDIS control bit will change the pins from external memory to I/O port functions. When EBDIS = 0, the pins function as the external bus. When EBDIS = 1, the pins function as I/O ports.

REGISTER 6-1: MEMCON: MEMORY CONTROL REGISTER

R/W-0	U-0	R/W-0	R/W-0	U-0	U-0	R/W-0	R/W-0
EBDIS	—	WAIT1	WAIT0	—	—	WM1	WM0
bit 7						bit 0	

- bit 7 **EBDIS:** External Bus Disable bit
1 = External system bus disabled, all external bus drivers are mapped as I/O ports
0 = External system bus enabled and I/O ports are disabled
 - bit 6 **Unimplemented:** Read as '0'
 - bit 5-4 **WAIT1:WAIT0:** Table Reads and Writes Bus Cycle Wait Count bits
11 = Table reads and writes will wait 0 T_{CY}
10 = Table reads and writes will wait 1 T_{CY}
01 = Table reads and writes will wait 2 T_{CY}
00 = Table reads and writes will wait 3 T_{CY}
 - bit 3-2 **Unimplemented:** Read as '0'
 - bit 1-0 **WM1:WM0:** TBLWRT Operation with 16-Bit Bus bits
1x = Word Write mode: TABLAT<0> and TABLAT<1> word output, \overline{WRH} active when TABLAT<1> written
01 = Byte Select mode: TABLAT data copied on both MSB and LSB, \overline{WRH} and (\overline{UB} or \overline{LB}) will activate
00 = Byte Write mode: TABLAT data copied on both MSB and LSB, \overline{WRH} or \overline{WRL} will activate
- Note:** The MEMCON register is unimplemented and reads all '0's when the device is in Microcontroller mode.

Legend:

R = Readable bit	W = Writable bit	U = Unimplemented bit, read as '0'
-n = Value at POR	'1' = Bit is set	'0' = Bit is cleared x = Bit is unknown

PIC18F6525/6621/8525/8621

If the device fetches or accesses external memory while $EBDIS = 1$, the pins will switch to external bus. If the $EBDIS$ bit is set by a program executing from external memory, the action of setting the bit will be delayed until the program branches into the internal memory. At that time, the pins will change from external bus to I/O ports.

When the device is executing out of internal memory ($EBDIS = 0$) in Microprocessor with Boot Block mode or Extended Microcontroller mode, the control signals will NOT be active. They will go to a state where the $AD_{<15:0>}$ and $A_{<19:16>}$ are tri-state; the \overline{CE} , \overline{OE} , \overline{WRH} , \overline{WRL} , \overline{UB} and \overline{LB} signals are '1' and ALE and $BA0$ are '0'.

TABLE 6-1: PIC18F8525/8621 EXTERNAL BUS – I/O PORT FUNCTIONS

Name	Port	Bit	Function
RD0/AD0	PORTD	bit 0	Input/Output or System Bus Address bit 0 or Data bit 0
RD1/AD1	PORTD	bit 1	Input/Output or System Bus Address bit 1 or Data bit 1
RD2/AD2	PORTD	bit 2	Input/Output or System Bus Address bit 2 or Data bit 2
RD3/AD3	PORTD	bit 3	Input/Output or System Bus Address bit 3 or Data bit 3
RD4/AD4	PORTD	bit 4	Input/Output or System Bus Address bit 4 or Data bit 4
RD5/AD5	PORTD	bit 5	Input/Output or System Bus Address bit 5 or Data bit 5
RD6/AD6	PORTD	bit 6	Input/Output or System Bus Address bit 6 or Data bit 6
RD7/AD7	PORTD	bit 7	Input/Output or System Bus Address bit 7 or Data bit 7
RE0/AD8	PORTE	bit 0	Input/Output or System Bus Address bit 8 or Data bit 8
RE1/AD9	PORTE	bit 1	Input/Output or System Bus Address bit 9 or Data bit 9
RE2/AD10	PORTE	bit 2	Input/Output or System Bus Address bit 10 or Data bit 10
RE3/AD11	PORTE	bit 3	Input/Output or System Bus Address bit 11 or Data bit 11
RE4/AD12	PORTE	bit 4	Input/Output or System Bus Address bit 12 or Data bit 12
RE5/AD13	PORTE	bit 5	Input/Output or System Bus Address bit 13 or Data bit 13
RE6/AD14	PORTE	bit 6	Input/Output or System Bus Address bit 14 or Data bit 14
RE7/AD15	PORTE	bit 7	Input/Output or System Bus Address bit 15 or Data bit 15
RH0/A16	PORTH	bit 0	Input/Output or System Bus Address bit 16
RH1/A17	PORTH	bit 1	Input/Output or System Bus Address bit 17
RH2/A18	PORTH	bit 2	Input/Output or System Bus Address bit 18
RH3/A19	PORTH	bit 3	Input/Output or System Bus Address bit 19
RJ0/ALE	PORTJ	bit 0	Input/Output or System Bus Address Latch Enable (ALE) Control pin
RJ1/ \overline{OE}	PORTJ	bit 1	Input/Output or System Bus Output Enable (\overline{OE}) Control pin
RJ2/ \overline{WRL}	PORTJ	bit 2	Input/Output or System Bus Write Low (\overline{WRL}) Control pin
RJ3/ \overline{WRH}	PORTJ	bit 3	Input/Output or System Bus Write High (\overline{WRH}) Control pin
RJ4/BA0	PORTJ	bit 4	Input/Output or System Bus Byte Address bit 0
RJ5/ \overline{CE}	PORTJ	bit 5	Input/Output or System Bus Chip Enable (\overline{CE}) Control pin
RJ6/ \overline{LB}	PORTJ	bit 6	Input/Output or System Bus Lower Byte Enable (\overline{LB}) Control pin
RJ7/ \overline{UB}	PORTJ	bit 7	Input/Output or System Bus Upper Byte Enable (\overline{UB}) Control pin

PIC18F6525/6621/8525/8621

6.2 16-Bit Mode

The external memory interface implemented in PIC18F8525/8621 devices operates only in 16-bit mode. The mode selection is not software configurable but is programmed via the configuration bits.

The WM1:WM0 bits in the MEMCON register determine three types of connections in 16-bit mode. They are referred to as:

- 16-bit Byte Write
- 16-bit Word Write
- 16-bit Byte Select

These three different configurations allow the designer maximum flexibility in using 8-bit and 16-bit memory devices.

For all 16-bit modes, the Address Latch Enable (ALE) pin indicates that the address bits, A15:A0, are available on the external memory interface bus. Following the address latch, the Output Enable signal (\overline{OE}) will enable both bytes of program memory at once to form a 16-bit instruction word. The Chip Enable signal (\overline{CE}) is active at any time that the microcontroller accesses external memory, whether reading or writing; it is inactive (asserted high) whenever the device is in Sleep mode.

In Byte Select mode, JEDEC standard Flash memories will require BA0 for the byte address line and one I/O line, to select between Byte and Word mode. The other 16-bit modes do not need BA0. JEDEC standard static RAM memories will use the UB or LB signals for byte selection.

6.2.1 16-BIT BYTE WRITE MODE

Figure 6-1 shows an example of 16-bit Byte Write mode for PIC18F8525/8621 devices. This mode is used for two separate 8-bit memories connected for 16-bit operation. This generally includes basic EPROM and Flash devices. It allows table writes to byte-wide external memories.

During a TBLWT instruction cycle, the TABLAT data is presented on the upper and lower bytes of the AD15:AD0 bus. The appropriate \overline{WRH} or \overline{WRL} control line is strobed on the LSB of the TBLPTR.

FIGURE 6-1: 16-BIT BYTE WRITE MODE EXAMPLE

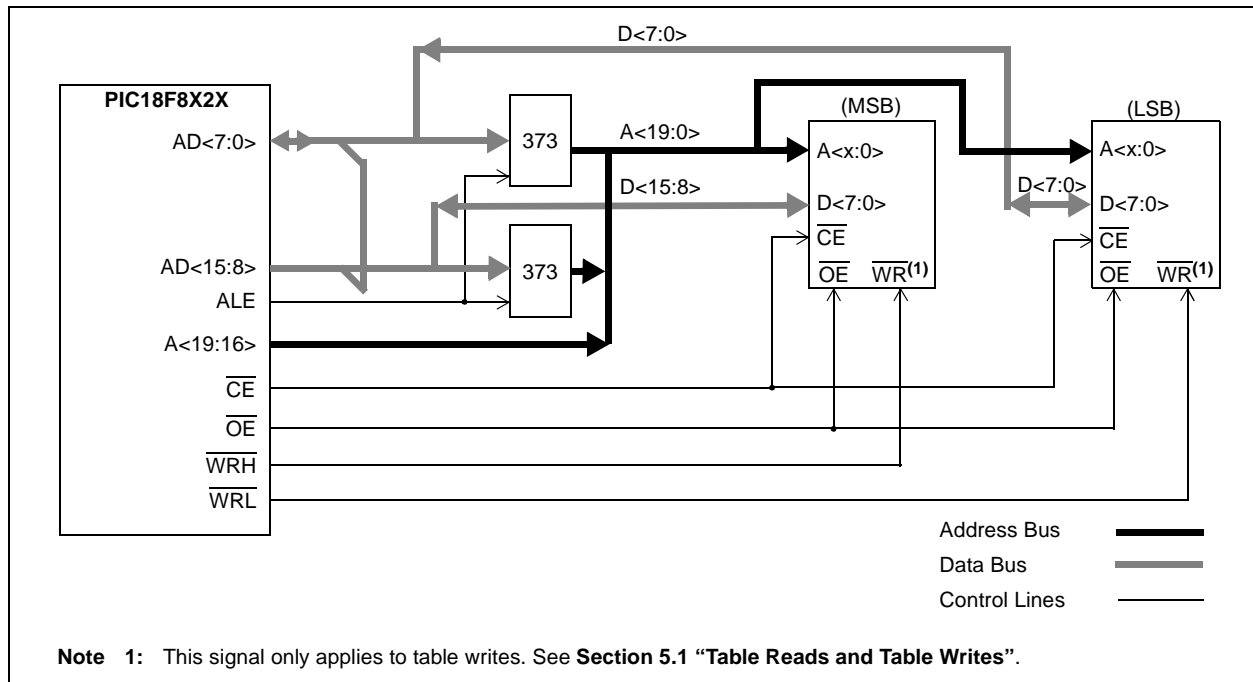

PIC18F6525/6621/8525/8621

6.2.2 16-BIT WORD WRITE MODE

Figure 6-2 shows an example of 16-bit Word Write mode for PIC18F8525/8621 devices. This mode is used for word-wide memories which include some of the EPROM and Flash type memories. This mode allows opcode fetches and table reads from all forms of 16-bit memory and table writes to any type of word-wide external memories. This method makes a distinction between TBLWT cycles to even or odd addresses.

During a TBLWT cycle to an even address (TBLPTR<0> = 0), the TABLAT data is transferred to a holding latch and the external address data bus is tristated for the data portion of the bus cycle. No write signals are activated.

During a TBLWT cycle to an odd address (TBLPTR<0> = 1), the TABLAT data is presented on the upper byte of the AD15:AD0 bus. The contents of the holding latch are presented on the lower byte of the AD15:AD0 bus.

The \overline{WRH} signal is strobed for each write cycle; the \overline{WRL} pin is unused. The signal on the BA0 pin indicates the LSB of the TBLPTR but it is left unconnected. Instead, the \overline{UB} and \overline{LB} signals are active to select both bytes. The obvious limitation to this method is that the table write must be done in pairs on a specific word boundary to correctly write a word location.

FIGURE 6-2: 16-BIT WORD WRITE MODE EXAMPLE

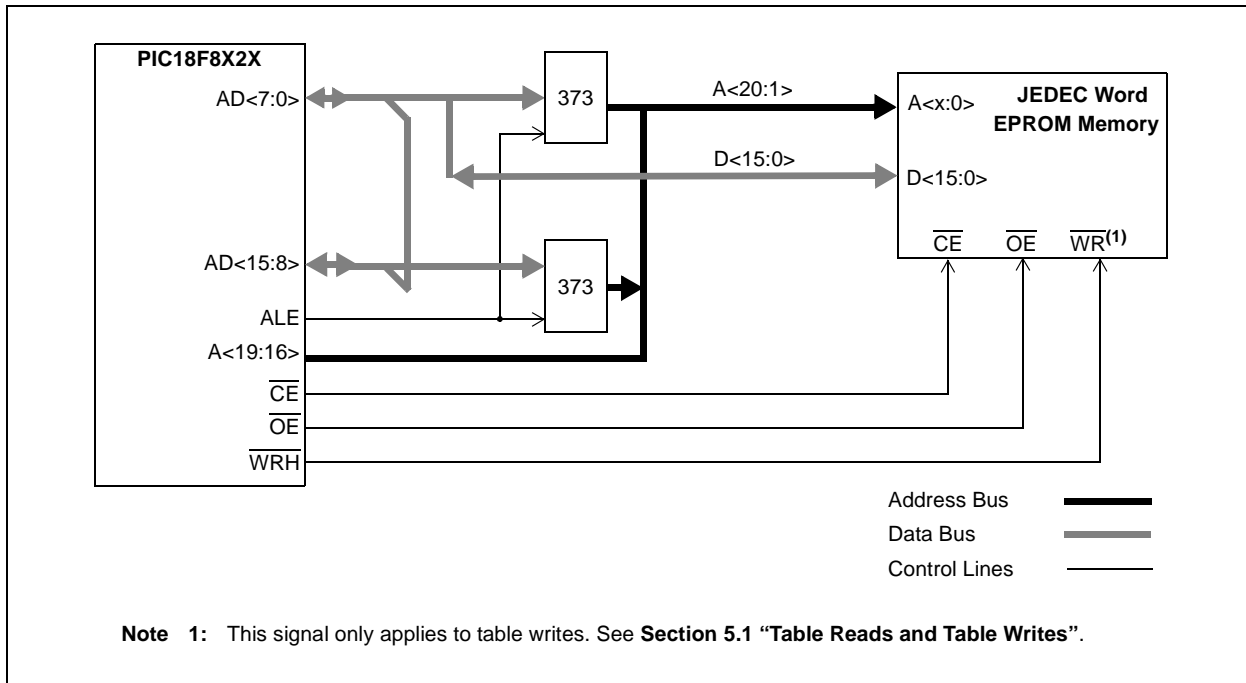

PIC18F6525/6621/8525/8621

6.2.3 16-BIT BYTE SELECT MODE

Figure 6-3 shows an example of 16-bit Byte Select mode for PIC18F8525/8621 devices. This mode allows table write operations to word-wide external memories with byte selection capability. This generally includes both word-wide Flash and SRAM devices.

During a TBLWT cycle, the TABLAT data is presented on the upper and lower byte of the AD15:AD0 bus. The WRH signal is strobed for each write cycle; the WRL pin is not used. The BA0 or $\overline{UB}/\overline{LB}$ signals are used to select the byte to be written based on the Least Significant bit of the TBLPTR register.

Flash and SRAM devices use different control signal combinations to implement Byte Select mode. JEDEC standard Flash memories require that a controller I/O port pin be connected to the memory's $\overline{BYTE}/\overline{WORD}$ pin to provide the select signal. They also use the BA0 signal from the controller as a byte address. JEDEC standard static RAM memories, on the other hand, use the \overline{UB} or \overline{LB} signals to select the byte.

FIGURE 6-3: 16-BIT BYTE SELECT MODE EXAMPLE

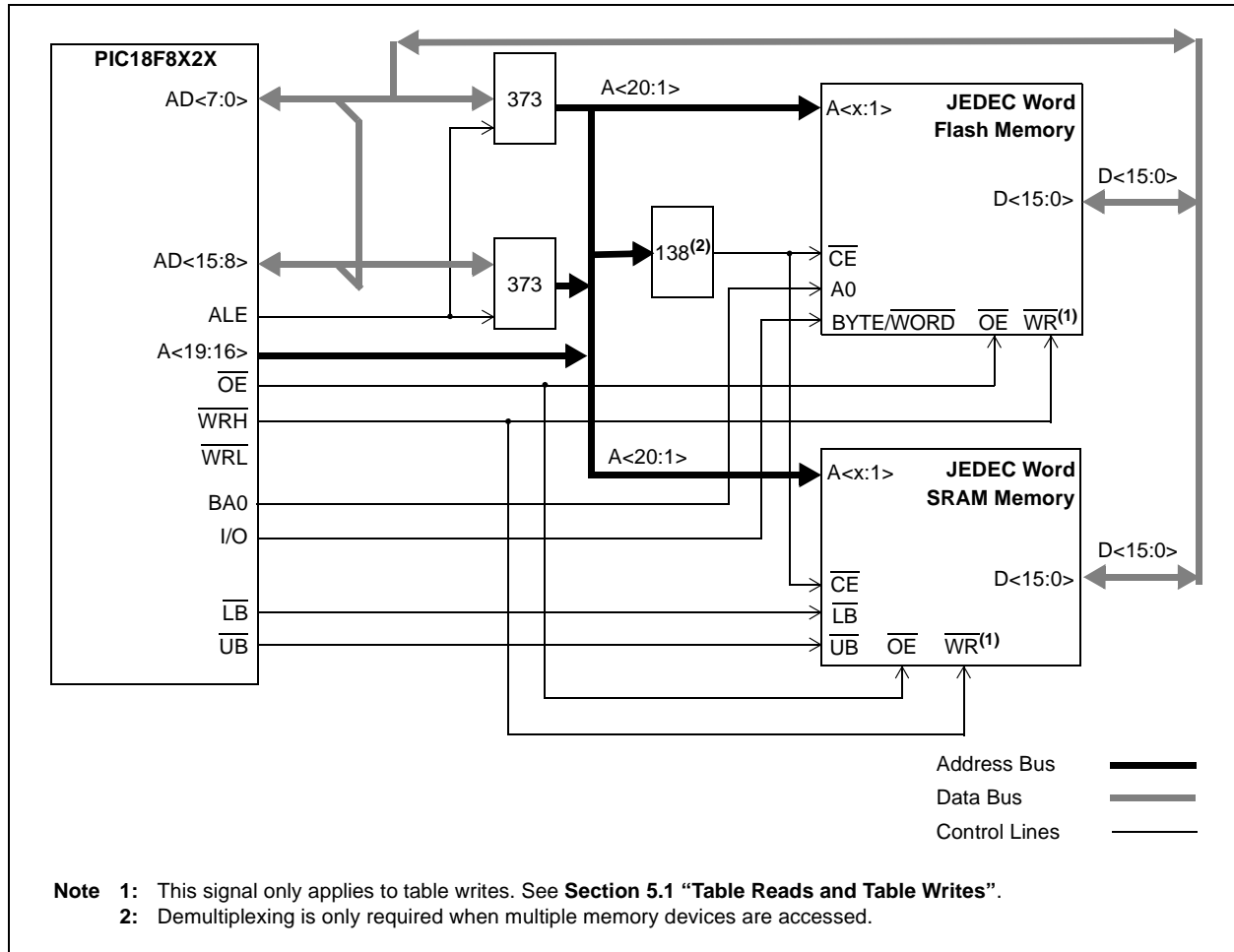

PIC18F6525/6621/8525/8621

6.2.4 16-BIT MODE TIMING

The presentation of control signals on the external memory bus is different for the various operating modes. Typical signal timing diagrams are shown in Figure 6-4 through Figure 6-6.

FIGURE 6-4: EXTERNAL MEMORY BUS TIMING FOR TBLRD (MICROPROCESSOR MODE)

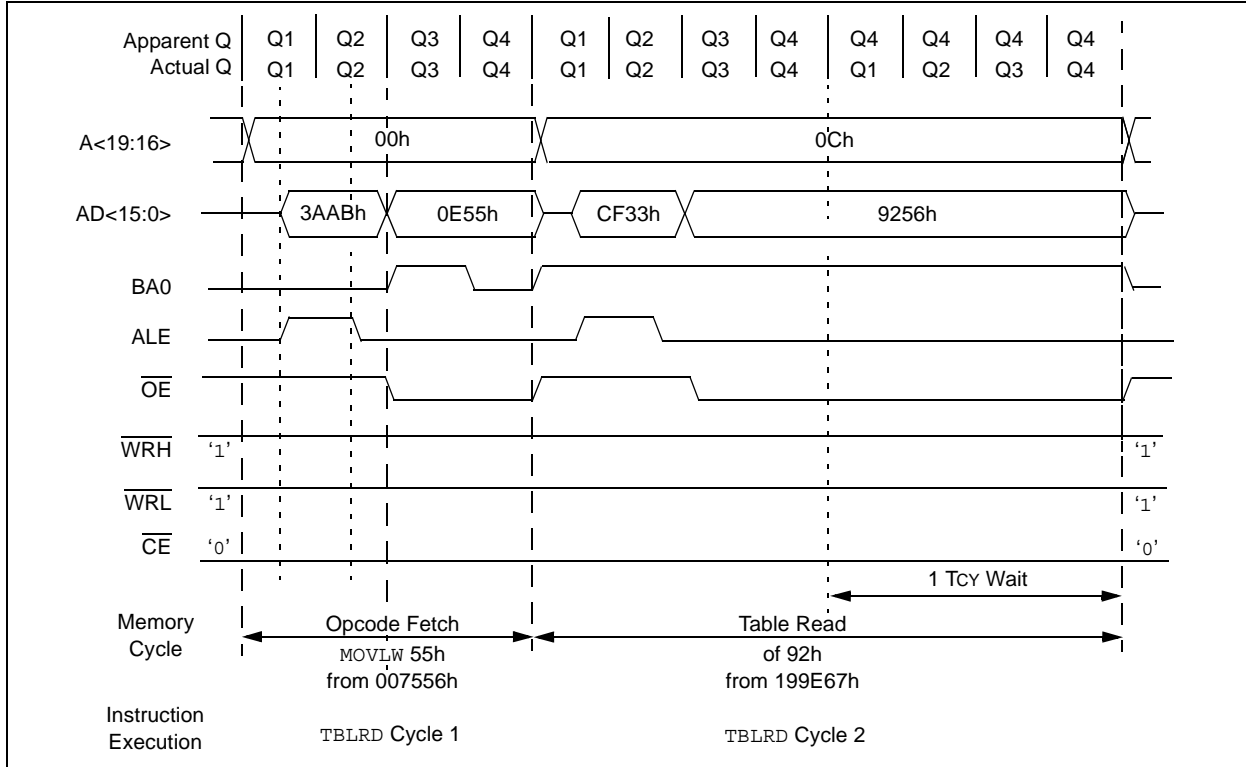
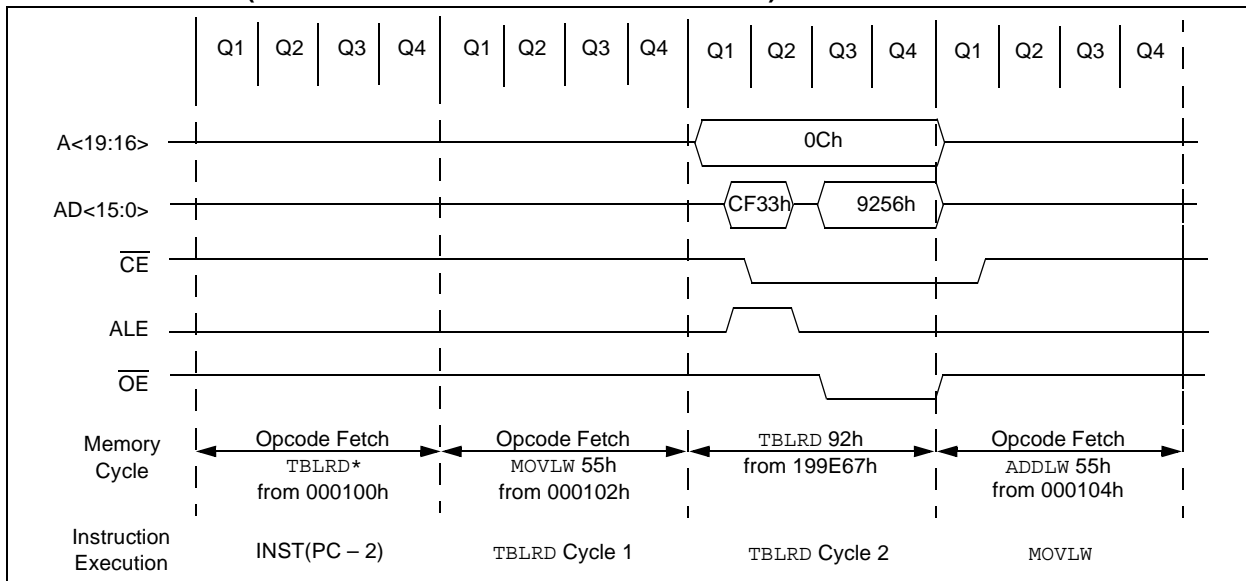
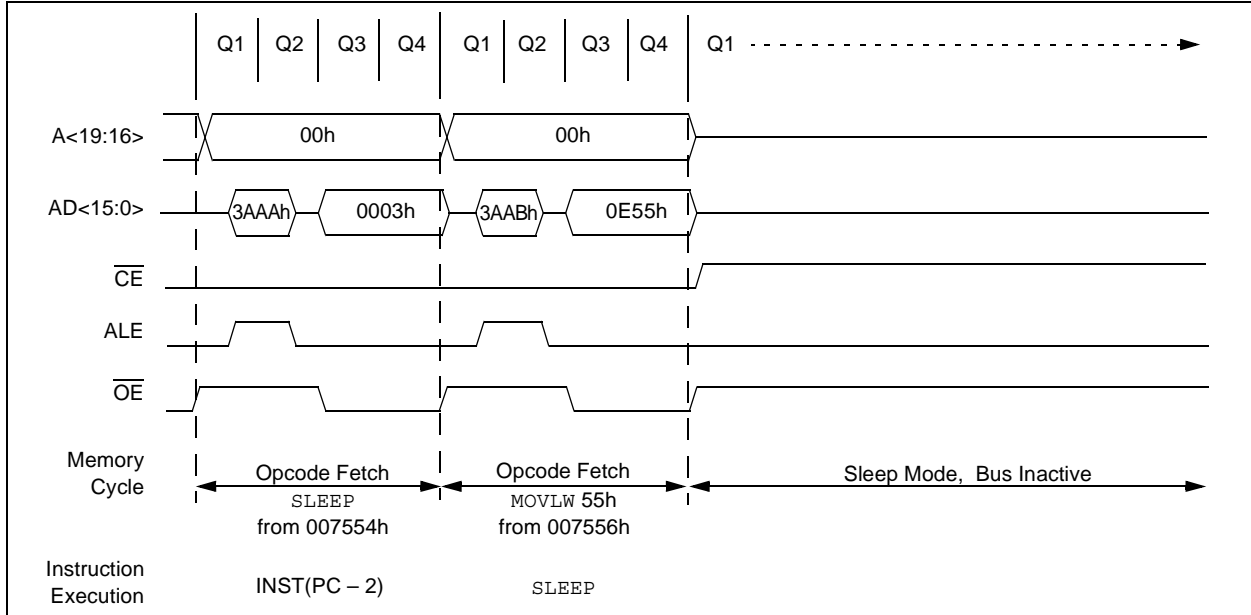

FIGURE 6-5: EXTERNAL MEMORY BUS TIMING FOR TBLRD (EXTENDED MICROCONTROLLER MODE)



PIC18F6525/6621/8525/8621

FIGURE 6-6: EXTERNAL MEMORY BUS TIMING FOR SLEEP (MICROPROCESSOR MODE)



PIC18F6525/6621/8525/8621

NOTES:

7.0 DATA EEPROM MEMORY

The data EEPROM is readable and writable during normal operation over the entire V_{DD} range. The data memory is not directly mapped in the register file space. Instead, it is indirectly addressed through the Special Function Registers (SFR).

There are five SFRs used to read and write the program and data EEPROM memory. These registers are:

- EECON1
- EECON2
- EEDATA
- EEADRH
- EEADR

The EEPROM data memory allows byte read and write. When interfacing to the data memory block, EEDATA holds the 8-bit data for read/write. EEADR and EEADRH hold the address of the EEPROM location being accessed. These devices have 1024 bytes of data EEPROM with an address range from 00h to 3FFh.

The EEPROM data memory is rated for high erase/write cycles. A byte write automatically erases the location and writes the new data (erase-before-write). The write time is controlled by an on-chip timer. The write time will vary with voltage and temperature, as well as from chip-to-chip. Please refer to parameter D122 (Section 27.0 “Electrical Characteristics”) for exact limits.

7.1 EEADR and EEADRH

The address register pair can address up to a maximum of 1024 bytes of data EEPROM. The two Most Significant bits of the address are stored in EEADRH, while the remaining eight Least Significant bits are stored in EEADR. The six Most Significant bits of EEADRH are unused and are read as ‘0’.

7.2 EECON1 and EECON2 Registers

EECON1 is the control register for EEPROM memory accesses.

EECON2 is not a physical register. Reading EECON2 will read all ‘0’s. The EECON2 register is used exclusively in the EEPROM write sequence.

Control bits RD and WR initiate read and write operations, respectively. These bits cannot be cleared, only set in software. They are cleared in hardware at the completion of the read or write operation. The inability to clear the WR bit in software prevents the accidental or premature termination of a write operation.

Note: During normal operation, the WRERR bit is read as ‘1’. This can indicate that a write operation was prematurely terminated by a Reset, or a write operation was attempted improperly.

The WREN bit, when set, will allow a write operation. On power-up, the WREN bit is clear. The WRERR bit is set when a write operation is interrupted by a MCLR Reset or a WDT Time-out Reset during normal operation. In these situations, the user can check the WRERR bit and rewrite the location. It is necessary to reload the data and address registers (EEDATA and EEADR) due to the Reset condition forcing the contents of the registers to zero.

Note: Interrupt flag bit, EEIF in the PIR2 register, is set when write is complete. It must be cleared in software.

PIC18F6525/6621/8525/8621

REGISTER 7-1: EECON1 REGISTER (ADDRESS FA6h)

R/W-x	R/W-x	U-0	R/W-0	R/W-x	R/W-0	R/S-0	R/S-0	
EEPGD	CFGS	—	FREE	WRERR	WREN	WR	RD	
bit 7								bit 0

- bit 7 **EEPGD:** Flash Program/Data EEPROM Memory Select bit
 1 = Access Flash program memory
 0 = Access data EEPROM memory
- bit 6 **CFGS:** Flash Program/Data EEPROM or Configuration Select bit
 1 = Access Configuration or Calibration registers
 0 = Access Flash program or data EEPROM memory
- bit 5 **Unimplemented:** Read as '0'
- bit 4 **FREE:** Flash Row Erase Enable bit
 1 = Erase the program memory row addressed by TBLPTR on the next WR command (cleared by completion of erase operation)
 0 = Perform write only
- bit 3 **WRERR:** Flash Program/Data EEPROM Error Flag bit
 1 = A write operation is prematurely terminated (any MCLR or any WDT Reset during self-timed programming in normal operation)
 0 = The write operation completed
Note: When a WRERR occurs, the EEPGD or FREE bits are not cleared. This allows tracing of the error condition.
- bit 2 **WREN:** Flash Program/Data EEPROM Write Enable bit
 1 = Allows write cycles to Flash program/data EEPROM
 0 = Inhibits write cycles to Flash program/data EEPROM
- bit 1 **WR:** Write Control bit
 1 = Initiates a data EEPROM erase/write cycle or a program memory erase cycle or write cycle (The operation is self-timed and the bit is cleared by hardware once write is complete. The WR bit can only be set (not cleared) in software.)
 0 = Write cycle to the EEPROM is complete
- bit 0 **RD:** Read Control bit
 1 = Initiates an EEPROM read (Read takes one cycle. RD is cleared in hardware. The RD bit can only be set (not cleared) in software. RD bit cannot be set when EEPGD = 1.)
 0 = Does not initiate an EEPROM read

Legend:

R = Readable bit	W = Writable bit	U = Unimplemented bit, read as '0'
-n = Value at POR	'1' = Bit is set	'0' = Bit is cleared x = Bit is unknown

7.3 Reading the Data EEPROM Memory

To read a data memory location, the user must write the address to the EEADRH:EEADR register pair, clear the EEPGD control bit (EECON1<7>), clear the CFGS

control bit (EECON1<6>) and then set the RD control bit (EECON1<0>). The data is available for the very next instruction cycle; therefore, the EEDATA register can be read by the next instruction. EEDATA will hold this value until another read operation or until it is written to by the user (during a write operation).

EXAMPLE 7-1: DATA EEPROM READ

```

MOVLW DATA_EE_ADDRH      ;
MOVWF  EEADRH             ; Upper bits of Data Memory Address to read
MOVLW DATA_EE_ADDR      ;
MOVWF  EEADR              ; Lower bits of Data Memory Address to read
BCF    EECON1, EEPGD      ; Point to DATA memory
BCF    EECON1, CFGS      ; Access EEPROM
BSF    EECON1, RD         ; EEPROM Read
MOVF  EEDATA, W           ; W = EEDATA
    
```

7.4 Writing to the Data EEPROM Memory

To write an EEPROM data location, the address must first be written to the EEADRH:EEADR register pair and the data written to the EEDATA register. Then the sequence in Example 7-2 must be followed to initiate the write cycle.

The write will not initiate if the above sequence is not exactly followed (write 55h to EECON2, write AAh to EECON2, then set WR bit) for each byte. It is strongly recommended that interrupts be disabled during this code segment.

Additionally, the WREN bit in EECON1 must be set to enable writes. This mechanism prevents accidental writes to data EEPROM due to unexpected code

execution (i.e., runaway programs). The WREN bit should be kept clear at all times except when updating the EEPROM. The WREN bit is not cleared by hardware.

After a write sequence has been initiated, EECON1, EEADRH, EEADR and EEDATA cannot be modified. The WR bit will be inhibited from being set unless the WREN bit is set. Both WR and WREN cannot be set with the same instruction.

At the completion of the write cycle, the WR bit is cleared in hardware and the EEPROM Write Complete Interrupt Flag bit (EEIF) is set. The user may either enable this interrupt or poll this bit. EEIF must be cleared by software.

EXAMPLE 7-2: DATA EEPROM WRITE

```

MOVLW DATA_EE_ADDRH      ;
MOVWF  EEADRH             ; Upper bits of Data Memory Address to write
MOVLW DATA_EE_ADDR      ;
MOVWF  EEADR              ; Lower bits of Data Memory Address to write
MOVLW DATA_EE_DATA      ;
MOVWF  EEDATA             ; Data Memory Value to write
BCF    EECON1, EEPGD      ; Point to DATA memory
BCF    EECON1, CFGS      ; Access EEPROM
BSF    EECON1, WREN      ; Enable writes

BCF    INTCON, GIE        ; Disable Interrupts
MOVLW  0x55               ;
Required MOVWF EECON2      ; Write 55h
Sequence MOVLW  0xAA       ;
MOVWF  EECON2             ; Write AAh
BSF    EECON1, WR         ; Set WR bit to begin write
BSF    INTCON, GIE        ; Enable Interrupts

; User code execution
BCF    EECON1, WREN      ; Disable writes on write complete (EEIF set)
    
```

PIC18F6525/6621/8525/8621

7.5 Write Verify

Depending on the application, good programming practice may dictate that the value written to the memory should be verified against the original value. This should be used in applications where excessive writes can stress bits near the specification limit.

7.6 Protection Against Spurious Write

There are conditions when the user may not want to write to the data EEPROM memory. To protect against spurious EEPROM writes, various mechanisms have been built-in. On power-up, the WREN bit is cleared. Also, the Power-up Timer (72 ms duration) prevents EEPROM write.

The write initiate sequence and the WREN bit together help prevent an accidental write during brown-out, power glitch or software malfunction.

7.7 Operation During Code-Protect

Data EEPROM memory has its own code-protect mechanism. External read and write operations are disabled if either of these mechanisms are enabled. Refer to **Section 24.0 “Special Features of the CPU”**, for additional information.

7.8 Using the Data EEPROM

The data EEPROM is a high endurance, byte addressable array that has been optimized for the storage of frequently changing information (e.g., program variables or other data that are updated often). Frequently changing values will typically be updated more often than specification D124. If this is not the case, an array refresh must be performed. For this reason, variables that change infrequently (such as constants, IDs, calibration, etc.) should be stored in Flash program memory.

A simple data EEPROM refresh routine is shown in Example 7-3.

EXAMPLE 7-3: DATA EEPROM REFRESH ROUTINE

```
CLRF    EEADR           ; Start at address 0
CLRF    EEADRH          ;
BCF     EECON1, CFGS    ; Set for memory
BCF     EECON1, EEPGD   ; Set for Data EEPROM
BCF     INTCON, GIE     ; Disable interrupts
BSF     EECON1, WREN    ; Enable writes
Loop    ; Loop to refresh array
BSF     EECON1, RD      ; Read current address
MOVLW  55h              ;
MOVWF  EECON2          ; Write 55h
MOVLW  AAh              ;
MOVWF  EECON2          ; Write AAh
BSF     EECON1, WR      ; Set WR bit to begin write
BTFSC  EECON1, WR      ; Wait for write to complete
BRA    $-2              ;
INCFSZ EEADR, F        ; Increment address
BRA    Loop             ; Not zero, do it again
INCFSZ EEADRH, F      ; Increment the high address
BRA    Loop             ; Not zero, do it again

BCF     EECON1, WREN    ; Disable writes
BSF     INTCON, GIE     ; Enable interrupts
```

PIC18F6525/6621/8525/8621

TABLE 7-1: REGISTERS ASSOCIATED WITH DATA EEPROM MEMORY

Name	Bit 7	Bit 6	Bit 5	Bit 4	Bit 3	Bit 2	Bit 1	Bit 0	Value on: POR, BOR	Value on all other Resets
INTCON	GIE/GIEH	PEIE/GIEL	TMR0IE	INT0IE	RBIE	TMR0IF	INT0IF	RBIF	0000 000x	0000 000u
EEADRH	—	—	—	—	—	—	EE Addr Register High		---- --00	---- --00
EEADR	Data EEPROM Address Register								0000 0000	0000 0000
EEDATA	Data EEPROM Data Register								0000 0000	0000 0000
EECON2	Data EEPROM Control Register 2 (not a physical register)								—	—
EECON1	EEPGD	CFGS	—	FREE	WRERR	WREN	WR	RD	xx-0 x000	uu-0 u000
IPR2	—	CMIP	—	EEIP	BCLIP	LVDIP	TMR3IP	CCP2IP	-1-1 1111	-1-1 1111
PIR2	—	CMIF	—	EEIF	BCLIF	LVDIF	TMR3IF	CCP2IF	-0-0 0000	---0 0000
PIE2	—	CMIE	—	EEIE	BCLIE	LVDIE	TMR3IE	CCP2IE	-0-0 0000	---0 0000

Legend: x = unknown, u = unchanged, — = unimplemented, read as '0'. Shaded cells are not used during Flash/EEPROM access.

PIC18F6525/6621/8525/8621

NOTES:

PIC18F6525/6621/8525/8621

8.0 8 x 8 HARDWARE MULTIPLIER

8.1 Introduction

An 8 x 8 hardware multiplier is included in the ALU of the PIC18F6525/6621/8525/8621 devices. By making the multiply a hardware operation, it completes in a single instruction cycle. This is an unsigned multiply that gives a 16-bit result. The result is stored in the 16-bit product register pair (PRODH:PRODL). The multiplier does not affect any flags in the ALUSTA register.

Making the 8 x 8 multiplier execute in a single cycle gives the following advantages:

- Higher computational throughput
- Reduces code size requirements for multiply algorithms

The performance increase allows the device to be used in applications previously reserved for Digital Signal Processors.

Table 8-1 shows a performance comparison between Enhanced devices using the single-cycle hardware multiply and performing the same function without the hardware multiply.

8.2 Operation

Example 8-1 shows the sequence to do an 8 x 8 unsigned multiply. Only one instruction is required when one argument of the multiply is already loaded in the WREG register.

Example 8-2 shows the sequence to do an 8 x 8 signed multiply. To account for the signed bits of the arguments, each argument's Most Significant bit (MSb) is tested and the appropriate subtractions are done.

EXAMPLE 8-1: 8 x 8 UNSIGNED MULTIPLY ROUTINE

```
MOVWF ARG1, W      ;
MULWF ARG2          ; ARG1 * ARG2 ->
                   ; PRODH:PRODL
```

EXAMPLE 8-2: 8 x 8 SIGNED MULTIPLY ROUTINE

```
MOVWF ARG1, W      ;
MULWF ARG2          ; ARG1 * ARG2 ->
                   ; PRODH:PRODL
BTFSC ARG2, SB     ; Test Sign Bit
SUBWF PRODH, F     ; PRODH = PRODH
                   ; - ARG1
MOVWF ARG2, W      ;
BTFSC ARG1, SB     ; Test Sign Bit
SUBWF PRODH, F     ; PRODH = PRODH
                   ; - ARG2
```

TABLE 8-1: PERFORMANCE COMPARISON

Routine	Multiply Method	Program Memory (Words)	Cycles (Max)	Time		
				@ 40 MHz	@ 10 MHz	@ 4 MHz
8 x 8 unsigned	Without hardware multiply	13	69	6.9 μ s	27.6 μ s	69 μ s
	Hardware multiply	1	1	100 ns	400 ns	1 μ s
8 x 8 signed	Without hardware multiply	33	91	9.1 μ s	36.4 μ s	91 μ s
	Hardware multiply	6	6	600 ns	2.4 μ s	6 μ s
16 x 16 unsigned	Without hardware multiply	21	242	24.2 μ s	96.8 μ s	242 μ s
	Hardware multiply	24	24	2.4 μ s	9.6 μ s	24 μ s
16 x 16 signed	Without hardware multiply	52	254	25.4 μ s	102.6 μ s	254 μ s
	Hardware multiply	36	36	3.6 μ s	14.4 μ s	36 μ s

PIC18F6525/6621/8525/8621

Example 8-3 shows the sequence to do a 16 x 16 unsigned multiply. Equation 8-1 shows the algorithm that is used. The 32-bit result is stored in four registers, RES3:RES0.

EQUATION 8-1: 16 x 16 UNSIGNED MULTIPLICATION ALGORITHM

$$\begin{aligned} \text{RES3:RES0} &= \text{ARG1H:ARG1L} \cdot \text{ARG2H:ARG2L} \\ &= (\text{ARG1H} \cdot \text{ARG2H} \cdot 2^{16}) + \\ &\quad (\text{ARG1H} \cdot \text{ARG2L} \cdot 2^8) + \\ &\quad (\text{ARG1L} \cdot \text{ARG2H} \cdot 2^8) + \\ &\quad (\text{ARG1L} \cdot \text{ARG2L}) \end{aligned}$$

EXAMPLE 8-3: 16 x 16 UNSIGNED MULTIPLY ROUTINE

```

MOVF ARG1L, W
MULWF ARG2L          ; ARG1L * ARG2L ->
                    ; PRODH:PRODL

MOVFF PRODH, RES1 ;
MOVFF PRODL, RES0 ;
;

MOVF ARG1H, W
MULWF ARG2H          ; ARG1H * ARG2H ->
                    ; PRODH:PRODL

MOVFF PRODH, RES3 ;
MOVFF PRODL, RES2 ;
;

MOVF ARG1L, W
MULWF ARG2H          ; ARG1L * ARG2H ->
                    ; PRODH:PRODL

MOVF PRODL, W ;
ADDWF RES1, F ; Add cross
MOVF PRODH, W ; products
ADDWFC RES2, F ;
CLRF WREG ;
ADDWFC RES3, F ;
;

MOVF ARG1H, W ;
MULWF ARG2L          ; ARG1H * ARG2L ->
                    ; PRODH:PRODL

MOVF PRODL, W ;
ADDWF RES1, F ; Add cross
MOVF PRODH, W ; products
ADDWFC RES2, F ;
CLRF WREG ;
ADDWFC RES3, F ;
;

```

Example 8-4 shows the sequence to do a 16 x 16 signed multiply. Equation 8-2 shows the algorithm used. The 32-bit result is stored in four registers, RES3:RES0. To account for the signed bits of the arguments, each argument pairs' Most Significant bit (MSb) is tested and the appropriate subtractions are done.

EQUATION 8-2: 16 x 16 SIGNED MULTIPLICATION ALGORITHM

$$\begin{aligned} \text{RES3:RES0} &= \text{ARG1H:ARG1L} \cdot \text{ARG2H:ARG2L} \\ &= (\text{ARG1H} \cdot \text{ARG2H} \cdot 2^{16}) + \\ &\quad (\text{ARG1H} \cdot \text{ARG2L} \cdot 2^8) + \\ &\quad (\text{ARG1L} \cdot \text{ARG2H} \cdot 2^8) + \\ &\quad (\text{ARG1L} \cdot \text{ARG2L}) + \\ &\quad (-1 \cdot \text{ARG2H} \cdot 2^7) \cdot \text{ARG1H:ARG1L} \cdot 2^{16} + \\ &\quad (-1 \cdot \text{ARG1H} \cdot 2^7) \cdot \text{ARG2H:ARG2L} \cdot 2^{16} \end{aligned}$$

EXAMPLE 8-4: 16 x 16 SIGNED MULTIPLY ROUTINE

```

MOVF ARG1L, W
MULWF ARG2L          ; ARG1L * ARG2L ->
                    ; PRODH:PRODL

MOVFF PRODH, RES1 ;
MOVFF PRODL, RES0 ;
;

MOVF ARG1H, W
MULWF ARG2H          ; ARG1H * ARG2H ->
                    ; PRODH:PRODL

MOVFF PRODH, RES3 ;
MOVFF PRODL, RES2 ;
;

MOVF ARG1L, W
MULWF ARG2H          ; ARG1L * ARG2H ->
                    ; PRODH:PRODL

MOVF PRODL, W ;
ADDWF RES1, F ; Add cross
MOVF PRODH, W ; products
ADDWFC RES2, F ;
CLRF WREG ;
ADDWFC RES3, F ;
;

MOVF ARG1H, W ;
MULWF ARG2L          ; ARG1H * ARG2L ->
                    ; PRODH:PRODL

MOVF PRODL, W ;
ADDWF RES1, F ; Add cross
MOVF PRODH, W ; products
ADDWFC RES2, F ;
CLRF WREG ;
ADDWFC RES3, F ;
;

BTFS ARG2H, 7 ; ARG2H:ARG2L neg?
BRA SIGN_ARG1 ; no, check ARG1
MOVF ARG1L, W ;
SUBWF RES2 ;
MOVF ARG1H, W ;
SUBWFB RES3 ;
;

SIGN_ARG1
BTFS ARG1H, 7 ; ARG1H:ARG1L neg?
BRA CONT_CODE ; no, done
MOVF ARG2L, W ;
SUBWF RES2 ;
MOVF ARG2H, W ;
SUBWFB RES3 ;
;

CONT_CODE
:

```

9.0 INTERRUPTS

The PIC18F6525/6621/8525/8621 devices have multiple interrupt sources and an interrupt priority feature that allows each interrupt source to be assigned a high or a low priority level. The high priority interrupt vector is at 000008h, while the low priority interrupt vector is at 000018h. High priority interrupt events will override any low priority interrupts that may be in progress.

There are thirteen registers which are used to control interrupt operation. They are:

- RCON
- INTCON
- INTCON2
- INTCON3
- PIR1, PIR2, PIR3
- PIE1, PIE2, PIE3
- IPR1, IPR2, IPR3

It is recommended that the Microchip header files supplied with MPLAB® IDE be used for the symbolic bit names in these registers. This allows the assembler/compiler to automatically take care of the placement of these bits within the specified register.

Each interrupt source has three bits to control its operation. The functions of these bits are:

- Flag bit to indicate that an interrupt event occurred
- Enable bit that allows program execution to branch to the interrupt vector address when the flag bit is set
- Priority bit to select high priority or low priority

The interrupt priority feature is enabled by setting the IPEN bit (RCON<7>). When interrupt priority is enabled, there are two bits which enable interrupts globally. Setting the GIEH bit (INTCON<7>) enables all interrupts that have the priority bit set. Setting the GIEL bit (INTCON<6>) enables all interrupts that have the priority bit cleared. When the interrupt flag, enable bit and appropriate global interrupt enable bit are set, the interrupt will vector immediately to address 000008h or 000018h, depending on the priority level. Individual interrupts can be disabled through their corresponding enable bits.

When the IPEN bit is cleared (default state), the interrupt priority feature is disabled and interrupts are compatible with PICmicro® mid-range devices. In Compatibility mode, the interrupt priority bits for each source have no effect. INTCON<6> is the PEIE bit which enables/disables all peripheral interrupt sources. INTCON<7> is the GIE bit which enables/disables all interrupt sources. All interrupts branch to address 000008h in Compatibility mode.

When an interrupt is responded to, the global interrupt enable bit is cleared to disable further interrupts. If the IPEN bit is cleared, this is the GIE bit. If interrupt priority levels are used, this will be either the GIEH or GIEL bit. High priority interrupt sources can interrupt a low priority interrupt.

The return address is pushed onto the stack and the PC is loaded with the interrupt vector address (000008h or 000018h). Once in the Interrupt Service Routine, the source(s) of the interrupt can be determined by polling the interrupt flag bits. The interrupt flag bits must be cleared in software before re-enabling interrupts to avoid recursive interrupts.

The “return from interrupt” instruction, `RETFIE`, exits the interrupt routine and sets the GIE bit (GIEH or GIEL if priority levels are used) which re-enables interrupts.

For external interrupt events, such as the INT pins or the PORTB input change interrupt, the interrupt latency will be three to four instruction cycles. The exact latency is the same for one or two-cycle instructions. Individual interrupt flag bits are set regardless of the status of their corresponding enable bit or the GIE bit.

PIC18F6525/6621/8525/8621

FIGURE 9-1: INTERRUPT LOGIC

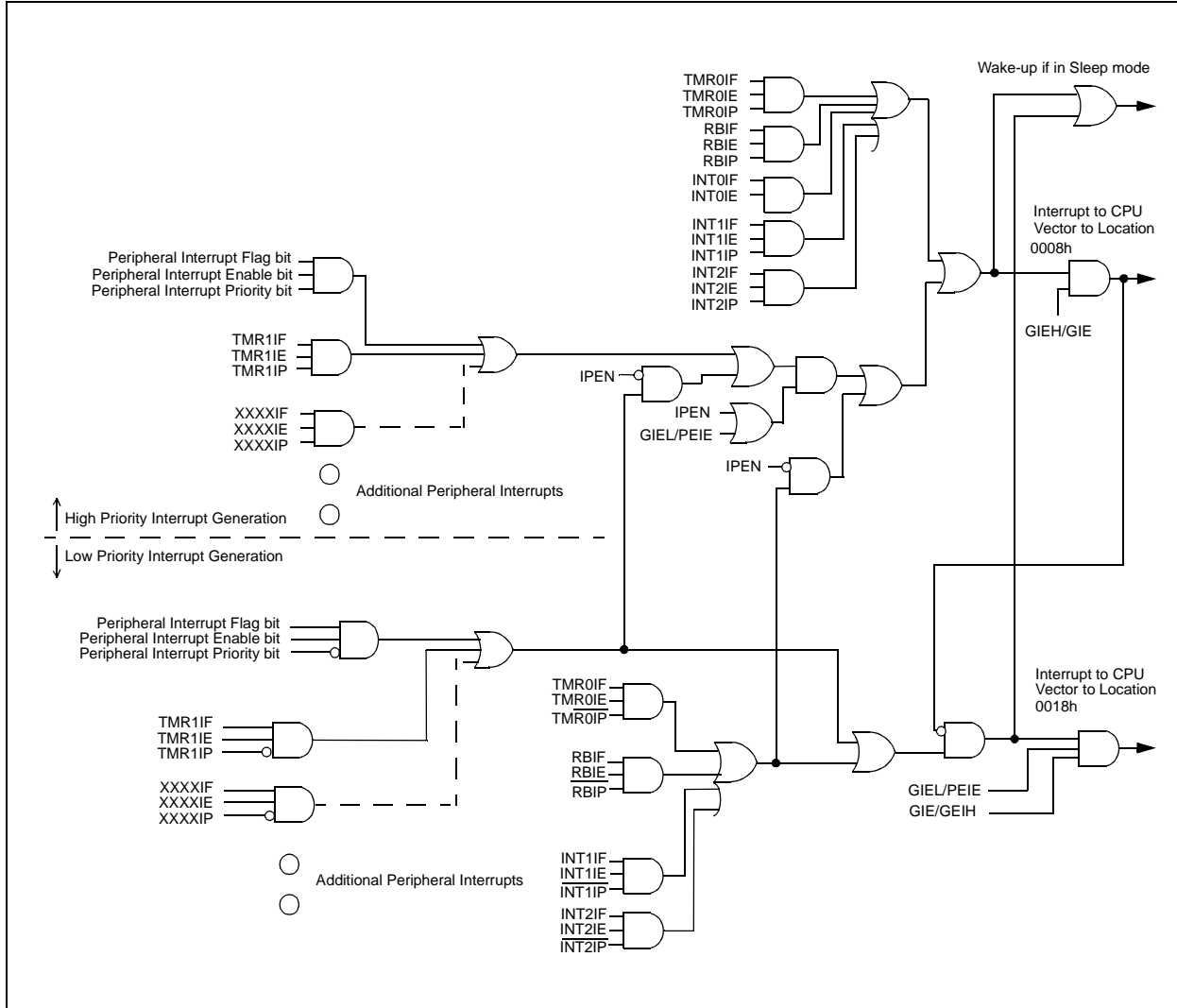

PIC18F6525/6621/8525/8621

9.1 INTCON Registers

The INTCON registers are readable and writable registers which contain various enable, priority and flag bits.

Note: Interrupt flag bits are set when an interrupt condition occurs, regardless of the state of its corresponding enable bit or the global interrupt enable bit. User software should ensure the appropriate interrupt flag bits are clear prior to enabling an interrupt. This feature allows for software polling.

REGISTER 9-1: INTCON: INTERRUPT CONTROL REGISTER

R/W-0	R/W-0	R/W-0	R/W-0	R/W-0	R/W-0	R/W-0	R/W-x
GIE/GIEH	PEIE/GIEL	TMR0IE	INT0IE	RBIE	TMR0IF	INT0IF	RBIF
bit 7							bit 0

- bit 7 **GIE/GIEH:** Global Interrupt Enable bit
When IPEN (RCON<7>) = 0:
 1 = Enables all unmasked interrupts
 0 = Disables all interrupts
When IPEN (RCON<7>) = 1:
 1 = Enables all high priority interrupts
 0 = Disables all interrupts
- bit 6 **PEIE/GIEL:** Peripheral Interrupt Enable bit
When IPEN (RCON<7>) = 0:
 1 = Enables all unmasked peripheral interrupts
 0 = Disables all peripheral interrupts
When IPEN (RCON<7>) = 1:
 1 = Enables all low priority peripheral interrupts
 0 = Disables all low priority peripheral interrupts
- bit 5 **TMR0IE:** TMR0 Overflow Interrupt Enable bit
 1 = Enables the TMR0 overflow interrupt
 0 = Disables the TMR0 overflow interrupt
- bit 4 **INT0IE:** INT0 External Interrupt Enable bit
 1 = Enables the INT0 external interrupt
 0 = Disables the INT0 external interrupt
- bit 3 **RBIE:** RB Port Change Interrupt Enable bit
 1 = Enables the RB port change interrupt
 0 = Disables the RB port change interrupt
- bit 2 **TMR0IF:** TMR0 Overflow Interrupt Flag bit
 1 = TMR0 register has overflowed (must be cleared in software)
 0 = TMR0 register did not overflow
- bit 1 **INT0IF:** INT0 External Interrupt Flag bit
 1 = The INT0 external interrupt occurred (must be cleared in software)
 0 = The INT0 external interrupt did not occur
- bit 0 **RBIF:** RB Port Change Interrupt Flag bit
 1 = At least one of the RB7:RB4 pins changed state (must be cleared in software)
 0 = None of the RB7:RB4 pins have changed state

Note: A mismatch condition will continue to set this bit. Reading PORTB will end the mismatch condition and allow the bit to be cleared.

Legend:

R = Readable bit W = Writable bit U = Unimplemented bit, read as '0'
 -n = Value at POR '1' = Bit is set '0' = Bit is cleared x = Bit is unknown

PIC18F6525/6621/8525/8621

REGISTER 9-2: INTCON2: INTERRUPT CONTROL REGISTER 2

R/W-1	R/W-1	R/W-1	R/W-1	R/W-1	R/W-1	R/W-1	R/W-1
$\overline{\text{RBPU}}$	INTEDG0	INTEDG1	INTEDG2	INTEDG3	TMR0IP	INT3IP	RBIP
bit 7							bit 0

- bit 7 **$\overline{\text{RBPU}}$** : PORTB Pull-up Enable bit
 1 = All PORTB pull-ups are disabled
 0 = PORTB pull-ups are enabled by individual port latch values
- bit 6 **INTEDG0**: External Interrupt 0 Edge Select bit
 1 = Interrupt on rising edge
 0 = Interrupt on falling edge
- bit 5 **INTEDG1**: External Interrupt 1 Edge Select bit
 1 = Interrupt on rising edge
 0 = Interrupt on falling edge
- bit 4 **INTEDG2**: External Interrupt 2 Edge Select bit
 1 = Interrupt on rising edge
 0 = Interrupt on falling edge
- bit 3 **INTEDG3**: External Interrupt 3 Edge Select bit
 1 = Interrupt on rising edge
 0 = Interrupt on falling edge
- bit 2 **TMR0IP**: TMR0 Overflow Interrupt Priority bit
 1 = High priority
 0 = Low priority
- bit 1 **INT3IP**: INT3 External Interrupt Priority bit
 1 = High priority
 0 = Low priority
- bit 0 **RBIP**: RB Port Change Interrupt Priority bit
 1 = High priority
 0 = Low priority

Legend:

R = Readable bit W = Writable bit U = Unimplemented bit, read as '0'
 -n = Value at POR '1' = Bit is set '0' = Bit is cleared x = Bit is unknown

Note: Interrupt flag bits are set when an interrupt condition occurs, regardless of the state of its corresponding enable bit or the global interrupt enable bit. User software should ensure the appropriate interrupt flag bits are clear prior to enabling an interrupt. This feature allows for software polling.

PIC18F6525/6621/8525/8621

REGISTER 9-3: INTCON3: INTERRUPT CONTROL REGISTER 3

R/W-1	R/W-1	R/W-0	R/W-0	R/W-0	R/W-0	R/W-0	R/W-0
INT2IP	INT1IP	INT3IE	INT2IE	INT1IE	INT3IF	INT2IF	INT1IF
bit 7							bit 0

- bit 7 **INT2IP:** INT2 External Interrupt Priority bit
 1 = High priority
 0 = Low priority
- bit 6 **INT1IP:** INT1 External Interrupt Priority bit
 1 = High priority
 0 = Low priority
- bit 5 **INT3IE:** INT3 External Interrupt Enable bit
 1 = Enables the INT3 external interrupt
 0 = Disables the INT3 external interrupt
- bit 4 **INT2IE:** INT2 External Interrupt Enable bit
 1 = Enables the INT2 external interrupt
 0 = Disables the INT2 external interrupt
- bit 3 **INT1IE:** INT1 External Interrupt Enable bit
 1 = Enables the INT1 external interrupt
 0 = Disables the INT1 external interrupt
- bit 2 **INT3IF:** INT3 External Interrupt Flag bit
 1 = The INT3 external interrupt occurred (must be cleared in software)
 0 = The INT3 external interrupt did not occur
- bit 1 **INT2IF:** INT2 External Interrupt Flag bit
 1 = The INT2 external interrupt occurred (must be cleared in software)
 0 = The INT2 external interrupt did not occur
- bit 0 **INT1IF:** INT1 External Interrupt Flag bit
 1 = The INT1 external interrupt occurred (must be cleared in software)
 0 = The INT1 external interrupt did not occur

Legend:

R = Readable bit W = Writable bit U = Unimplemented bit, read as '0'
 -n = Value at POR '1' = Bit is set '0' = Bit is cleared x = Bit is unknown

Note: Interrupt flag bits are set when an interrupt condition occurs, regardless of the state of its corresponding enable bit or the global interrupt enable bit. User software should ensure the appropriate interrupt flag bits are clear prior to enabling an interrupt. This feature allows for software polling.

PIC18F6525/6621/8525/8621

9.2 PIR Registers

The PIR registers contain the individual flag bits for the peripheral interrupts. Due to the number of peripheral interrupt sources, there are three Peripheral Interrupt Request Flag registers (PIR1, PIR2 and PIR3).

Note 1: Interrupt flag bits are set when an interrupt condition occurs, regardless of the state of its corresponding enable bit or the Global Interrupt Enable bit, GIE (INTCON<7>).

2: User software should ensure the appropriate interrupt flag bits are cleared prior to enabling an interrupt and after servicing that interrupt.

REGISTER 9-4: PIR1: PERIPHERAL INTERRUPT REQUEST (FLAG) REGISTER 1

R/W-0	R/W-0	R-0	R-0	R/W-0	R/W-0	R/W-0	R/W-0
PSPIF ⁽¹⁾	ADIF	RC1IF	TX1IF	SSPIF	CCP1IF	TMR2IF	TMR1IF
						bit 0	
bit 7							

- bit 7 **PSPIF:** Parallel Slave Port Read/Write Interrupt Flag bit⁽¹⁾
 1 = A read or a write operation has taken place (must be cleared in software)
 0 = No read or write has occurred
Note 1: Enabled only in Microcontroller mode for PIC18F8525/8621 devices.
- bit 6 **ADIF:** A/D Converter Interrupt Flag bit
 1 = An A/D conversion completed (must be cleared in software)
 0 = The A/D conversion is not complete
- bit 5 **RC1IF:** USART1 Receive Interrupt Flag bit
 1 = The USART1 receive buffer, RCREGx, is full (cleared when RCREGx is read)
 0 = The USART1 receive buffer is empty
- bit 4 **TX1IF:** USART1 Transmit Interrupt Flag bit
 1 = The USART1 transmit buffer, TXREGx, is empty (cleared when TXREGx is written)
 0 = The USART1 transmit buffer is full
- bit 3 **SSPIF:** Master Synchronous Serial Port Interrupt Flag bit
 1 = The transmission/reception is complete (must be cleared in software)
 0 = Waiting to transmit/receive
- bit 2 **CCP1IF:** ECCP1 Interrupt Flag bit
Capture mode:
 1 = A TMR1 register capture occurred (must be cleared in software)
 0 = No TMR1 register capture occurred
Compare mode:
 1 = A TMR1 register compare match occurred (must be cleared in software)
 0 = No TMR1 register compare match occurred
PWM mode:
 Unused in this mode.
- bit 1 **TMR2IF:** TMR2 to PR2 Match Interrupt Flag bit
 1 = TMR2 to PR2 match occurred (must be cleared in software)
 0 = No TMR2 to PR2 match occurred
- bit 0 **TMR1IF:** TMR1 Overflow Interrupt Flag bit
 1 = TMR1 register overflowed (must be cleared in software)
 0 = TMR1 register did not overflow

Legend:

R = Readable bit	W = Writable bit	U = Unimplemented bit, read as '0'
-n = Value at POR	'1' = Bit is set	'0' = Bit is cleared x = Bit is unknown

PIC18F6525/6621/8525/8621

REGISTER 9-5: PIR2: PERIPHERAL INTERRUPT REQUEST (FLAG) REGISTER 2

U-0	R/W-0	U-0	R/W-0	R/W-0	R/W-0	R/W-0	R/W-0	
—	CMIF	—	EEIF	BCLIF	LVDIF	TMR3IF	CCP2IF	
bit 7								bit 0

- bit 7 **Unimplemented:** Read as '0'
- bit 6 **CMIF:** Comparator Interrupt Flag bit
 1 = The comparator input has changed (must be cleared in software)
 0 = The comparator input has not changed
- bit 5 **Unimplemented:** Read as '0'
- bit 4 **EEIF:** Data EEPROM/Flash Write Operation Interrupt Flag bit
 1 = The write operation is complete (must be cleared in software)
 0 = The write operation is not complete, or has not been started
- bit 3 **BCLIF:** Bus Collision Interrupt Flag bit
 1 = A bus collision occurred while the MSSP module (configured in I²C Master mode) was transmitting (must be cleared in software)
 0 = No bus collision occurred
- bit 2 **LVDIF:** Low-Voltage Detect Interrupt Flag bit
 1 = A low voltage condition occurred (must be cleared in software)
 0 = The device voltage is above the Low-Voltage Detect trip point
- bit 1 **TMR3IF:** TMR3 Overflow Interrupt Flag bit
 1 = TMR3 register overflowed (must be cleared in software)
 0 = TMR3 register did not overflow
- bit 0 **CCP2IF:** ECCP2 Interrupt Flag bit
Capture mode:
 1 = A TMR1 or TMR3 register capture occurred (must be cleared in software)
 0 = No TMR1 or TMR3 register capture occurred
Compare mode:
 1 = A TMR1 or TMR3 register compare match occurred (must be cleared in software)
 0 = No TMR1 or TMR3 register compare match occurred
PWM mode:
 Unused in this mode.

Legend:			
R = Readable bit	W = Writable bit	U = Unimplemented bit, read as '0'	
-n = Value at POR	'1' = Bit is set	'0' = Bit is cleared	x = Bit is unknown

PIC18F6525/6621/8525/8621

REGISTER 9-6: PIR3: PERIPHERAL INTERRUPT REQUEST (FLAG) REGISTER 3

U-0	U-0	R-0	R-0	R/W-0	R/W-0	R/W-0	R/W-0	
—	—	RC2IF	TX2IF	TMR4IF	CCP5IF	CCP4IF	CCP3IF	
bit 7								bit 0

- bit 7-6 **Unimplemented:** Read as '0'
- bit 5 **RC2IF:** USART2 Receive Interrupt Flag bit
 1 = The USART2 receive buffer, RCREGx, is full (cleared when RCREGx is read)
 0 = The USART2 receive buffer is empty
- bit 4 **TX2IF:** USART2 Transmit Interrupt Flag bit
 1 = The USART2 transmit buffer, TXREGx, is empty (cleared when TXREGx is written)
 0 = The USART2 transmit buffer is full
- bit 3 **TMR4IF:** TMR3 Overflow Interrupt Flag bit
 1 = TMR4 register overflowed (must be cleared in software)
 0 = TMR4 register did not overflow
- bit 2-0 **CCPxIF:** CCPx Interrupt Flag bit (ECCP3, CCP4 and CCP5)
Capture mode:
 1 = A TMR1 or TMR3 register capture occurred (must be cleared in software)
 0 = No TMR1 or TMR3 register capture occurred
Compare mode:
 1 = A TMR1 or TMR3 register compare match occurred (must be cleared in software)
 0 = No TMR1 or TMR3 register compare match occurred
PWM mode:
 Unused in this mode.

Legend:

R = Readable bit	W = Writable bit	U = Unimplemented bit, read as '0'
-n = Value at POR	'1' = Bit is set	'0' = Bit is cleared x = Bit is unknown

PIC18F6525/6621/8525/8621

9.3 PIE Registers

The PIE registers contain the individual enable bits for the peripheral interrupts. Due to the number of peripheral interrupt sources, there are three Peripheral Interrupt Enable registers (PIE1, PIE2 and PIE3). When the IPEN bit (RCON<7>) is '0', the PEIE bit must be set to enable any of these peripheral interrupts.

REGISTER 9-7: PIE1: PERIPHERAL INTERRUPT ENABLE REGISTER 1

R/W-0	R/W-0	R/W-0	R/W-0	R/W-0	R/W-0	R/W-0	R/W-0
PSPIE ⁽¹⁾	ADIE	RC1IE	TX1IE	SSPIE	CCP1IE	TMR2IE	TMR1IE
bit 7							bit 0

bit 7 **PSPIE:** Parallel Slave Port Read/Write Interrupt Enable bit⁽¹⁾

1 = Enables the PSP read/write interrupt
0 = Disables the PSP read/write interrupt

Note: Enabled only in Microcontroller mode for PIC18F8525/8621 devices.

bit 6 **ADIE:** A/D Converter Interrupt Enable bit

1 = Enables the A/D interrupt
0 = Disables the A/D interrupt

bit 5 **RC1IE:** USART1 Receive Interrupt Enable bit

1 = Enables the USART1 receive interrupt
0 = Disables the USART1 receive interrupt

bit 4 **TX1IE:** USART1 Transmit Interrupt Enable bit

1 = Enables the USART1 transmit interrupt
0 = Disables the USART1 transmit interrupt

bit 3 **SSPIE:** Master Synchronous Serial Port Interrupt Enable bit

1 = Enables the MSSP interrupt
0 = Disables the MSSP interrupt

bit 2 **CCP1IE:** ECCP1 Interrupt Enable bit

1 = Enables the ECCP1 interrupt
0 = Disables the ECCP1 interrupt

bit 1 **TMR2IE:** TMR2 to PR2 Match Interrupt Enable bit

1 = Enables the TMR2 to PR2 match interrupt
0 = Disables the TMR2 to PR2 match interrupt

bit 0 **TMR1IE:** TMR1 Overflow Interrupt Enable bit

1 = Enables the TMR1 overflow interrupt
0 = Disables the TMR1 overflow interrupt

Legend:

R = Readable bit	W = Writable bit	U = Unimplemented bit, read as '0'
-n = Value at POR	'1' = Bit is set	'0' = Bit is cleared x = Bit is unknown

PIC18F6525/6621/8525/8621

REGISTER 9-8: PIE2: PERIPHERAL INTERRUPT ENABLE REGISTER 2

U-0	R/W-0	U-0	R/W-0	R/W-0	R/W-0	R/W-0	R/W-0	
—	CMIE	—	EEIE	BCLIE	LVDIE	TMR3IE	CCP2IE	
bit 7								bit 0

- bit 7 **Unimplemented:** Read as '0'
- bit 6 **CMIE:** Comparator Interrupt Enable bit
1 = Enables the comparator interrupt
0 = Disables the comparator interrupt
- bit 5 **Unimplemented:** Read as '0'
- bit 4 **EEIE:** Data EEPROM/Flash Write Operation Interrupt Enable bit
1 = Enables the write operation interrupt
0 = Disables the write operation interrupt
- bit 3 **BCLIE:** Bus Collision Interrupt Enable bit
1 = Enables the bus collision interrupt
0 = Disables the bus collision interrupt
- bit 2 **LVDIE:** Low-Voltage Detect Interrupt Enable bit
1 = Enables the Low-Voltage Detect interrupt
0 = Disables the Low-Voltage Detect interrupt
- bit 1 **TMR3IE:** TMR3 Overflow Interrupt Enable bit
1 = Enables the TMR3 overflow interrupt
0 = Disables the TMR3 overflow interrupt
- bit 0 **CCP2IE:** ECCP2 Interrupt Enable bit
1 = Enables the ECCP2 interrupt
0 = Disables the ECCP2 interrupt

Legend:			
R = Readable bit	W = Writable bit	U = Unimplemented bit, read as '0'	
-n = Value at POR	'1' = Bit is set	'0' = Bit is cleared	x = Bit is unknown

PIC18F6525/6621/8525/8621

REGISTER 9-9: PIE3: PERIPHERAL INTERRUPT ENABLE REGISTER 3

U-0	U-0	R/W-0	R/W-0	R/W-0	R/W-0	R/W-0	R/W-0	
—	—	RC2IE	TX2IE	TMR4IE	CCP5IE	CCP4IE	CCP3IE	
bit 7								bit 0

bit 7-6 **Unimplemented:** Read as '0'

bit 5 **RC2IE:** USART2 Receive Interrupt Enable bit
1 = Enables the USART2 receive interrupt
0 = Disables the USART2 receive interrupt

bit 4 **TX2IE:** USART2 Transmit Interrupt Enable bit
1 = Enables the USART2 transmit interrupt
0 = Disables the USART2 transmit interrupt

bit 3 **TMR4IE:** TMR4 to PR4 Match Interrupt Enable bit
1 = Enables the TMR4 to PR4 match interrupt
0 = Disables the TMR4 to PR4 match interrupt

bit 2-0 **CCPxIE:** CCPx Interrupt Enable bit (ECCP3, CCP4 and CCP5)
1 = Enables the CCPx interrupt
0 = Disables the CCPx interrupt

Legend:

R = Readable bit	W = Writable bit	U = Unimplemented bit, read as '0'
-n = Value at POR	'1' = Bit is set	'0' = Bit is cleared x = Bit is unknown

PIC18F6525/6621/8525/8621

9.4 IPR Registers

The IPR registers contain the individual priority bits for the peripheral interrupts. Due to the number of peripheral interrupt sources, there are three Peripheral Interrupt Priority registers (IPR1, IPR2 and IPR3). The operation of the priority bits requires that the Interrupt Priority Enable (IPEN) bit be set.

REGISTER 9-10: IPR1: PERIPHERAL INTERRUPT PRIORITY REGISTER 1

R/W-1	R/W-1	R/W-1	R/W-1	R/W-1	R/W-1	R/W-1	R/W-1
PSPIP ⁽¹⁾	ADIP	RC1IP	TX1IP	SSPIP	CCP1IP	TMR2IP	TMR1IP
bit 7							bit 0

bit 7 **PSPIP:** Parallel Slave Port Read/Write Interrupt Priority bit⁽¹⁾

1 = High priority
0 = Low priority

Note: Enabled only in Microcontroller mode for PIC18F8525/8621 devices.

bit 6 **ADIP:** A/D Converter Interrupt Priority bit

1 = High priority
0 = Low priority

bit 5 **RC1IP:** USART1 Receive Interrupt Priority bit

1 = High priority
0 = Low priority

bit 4 **TX1IP:** USART1 Transmit Interrupt Priority bit

1 = High priority
0 = Low priority

bit 3 **SSPIP:** Master Synchronous Serial Port Interrupt Priority bit

1 = High priority
0 = Low priority

bit 2 **CCP1IP:** ECCP1 Interrupt Priority bit

1 = High priority
0 = Low priority

bit 1 **TMR2IP:** TMR2 to PR2 Match Interrupt Priority bit

1 = High priority
0 = Low priority

bit 0 **TMR1IP:** TMR1 Overflow Interrupt Priority bit

1 = High priority
0 = Low priority

Legend:

R = Readable bit
-n = Value at POR

W = Writable bit
'1' = Bit is set

U = Unimplemented bit, read as '0'
'0' = Bit is cleared
x = Bit is unknown

PIC18F6525/6621/8525/8621

REGISTER 9-11: IPR2: PERIPHERAL INTERRUPT PRIORITY REGISTER 2

U-0	R/W-1	U-0	R/W-1	R/W-1	R/W-1	R/W-1	R/W-1	
—	CMIP	—	EEIP	BCLIP	LVDIP	TMR3IP	CCP2IP	
bit 7								bit 0

- bit 7 **Unimplemented:** Read as '0'
- bit 6 **CMIP:** Comparator Interrupt Priority bit
 1 = High priority
 0 = Low priority
- bit 5 **Unimplemented:** Read as '0'
- bit 4 **EEIP:** Data EEPROM/Flash Write Operation Interrupt Priority bit
 1 = High priority
 0 = Low priority
- bit 3 **BCLIP:** Bus Collision Interrupt Priority bit
 1 = High priority
 0 = Low priority
- bit 2 **LVDIP:** Low-Voltage Detect Interrupt Priority bit
 1 = High priority
 0 = Low priority
- bit 1 **TMR3IP:** TMR3 Overflow Interrupt Priority bit
 1 = High priority
 0 = Low priority
- bit 0 **CCP2IP:** ECCP2 Interrupt Priority bit
 1 = High priority
 0 = Low priority

Legend:			
R = Readable bit	W = Writable bit	U = Unimplemented bit, read as '0'	
-n = Value at POR	'1' = Bit is set	'0' = Bit is cleared	x = Bit is unknown

PIC18F6525/6621/8525/8621

REGISTER 9-12: IPR3: PERIPHERAL INTERRUPT PRIORITY REGISTER 3

U-0	U-0	R/W-1	R/W-1	R/W-1	R/W-1	R/W-1	R/W-1	
—	—	RC2IP	TX2IP	TMR4IP	CCP5IP	CCP4IP	CCP3IP	
bit 7								bit 0

- bit 7-6 **Unimplemented:** Read as '0'
- bit 5 **RC2IP:** USART2 Receive Interrupt Priority bit
1 = High priority
0 = Low priority
- bit 4 **TX2IP:** USART2 Transmit Interrupt Priority bit
1 = High priority
0 = Low priority
- bit 3 **TMR4IP:** TMR4 to PR4 Match Interrupt Priority bit
1 = High priority
0 = Low priority
- bit 2-0 **CCPxIP:** CCPx Interrupt Priority bit (ECCP3, CCP4 and CCP5)
1 = High priority
0 = Low priority

Legend:			
R = Readable bit	W = Writable bit	U = Unimplemented bit, read as '0'	
-n = Value at POR	'1' = Bit is set	'0' = Bit is cleared	x = Bit is unknown

PIC18F6525/6621/8525/8621

9.5 RCON Register

The RCON register contains the IPEN bit which is used to enable prioritized interrupts. The functions of the other bits in this register are discussed in more detail in **Section 4.14 “RCON Register”**.

REGISTER 9-13: RCON: RESET CONTROL REGISTER

R/W-0	U-0	U-0	R/W-1	R-1	R-1	R/W-0	R/W-0
IPEN	—	—	\overline{RI}	\overline{TO}	\overline{PD}	\overline{POR}	\overline{BOR}
bit 7							bit 0

- bit 7 **IPEN:** Interrupt Priority Enable bit
1 = Enable priority levels on interrupts
0 = Disable priority levels on interrupts (PIC16 Compatibility mode)
- bit 6-5 **Unimplemented:** Read as '0'
- bit 4 **\overline{RI} :** RESET Instruction Flag bit
For details of bit operation, see Register 4-4.
- bit 3 **\overline{TO} :** Watchdog Time-out Flag bit
For details of bit operation, see Register 4-4.
- bit 2 **\overline{PD} :** Power-down Detection Flag bit
For details of bit operation, see Register 4-4.
- bit 1 **\overline{POR} :** Power-on Reset Status bit
For details of bit operation, see Register 4-4.
- bit 0 **\overline{BOR} :** Brown-out Reset Status bit
For details of bit operation, see Register 4-4.

Legend:

R = Readable bit	W = Writable bit	U = Unimplemented bit, read as '0'
-n = Value at POR	'1' = Bit is set	'0' = Bit is cleared x = Bit is unknown

PIC18F6525/6621/8525/8621

9.6 INT0 Interrupt

External interrupts on the RB0/INT0/FLT0, RB1/INT1, RB2/INT2 and RB3/INT3 pins are edge-triggered; either rising if the corresponding INTEDGx bit is set in the INTCON2 register, or falling if the INTEDGx bit is clear. When a valid edge appears on the RBx/INTx pin, the corresponding flag bit, INTxF, is set. This interrupt can be disabled by clearing the corresponding enable bit, INTxE. Flag bit, INTxF, must be cleared in software in the Interrupt Service Routine before re-enabling the interrupt. All external interrupts (INT0, INT1, INT2 and INT3) can wake-up the processor from Sleep if bit INTxIE was set prior to going into Sleep. If the Global Interrupt Enable bit, GIE, is set, the processor will branch to the interrupt vector following wake-up.

The interrupt priority for INT1, INT2 and INT3 is determined by the value contained in the interrupt priority bits: INT1IP (INTCON3<6>), INT2IP (INTCON3<7>) and INT3IP (INTCON2<1>). There is no priority bit associated with INT0; it is always a high priority interrupt source.

9.7 TMR0 Interrupt

In 8-bit mode (which is the default), an overflow in the TMR0 register (FFh → 00h) will set flag bit TMR0IF. In 16-bit mode, an overflow in the TMR0H:TMR0L registers (FFFFh → 0000h) will set flag bit TMR0IF. The interrupt can be enabled/disabled by setting/clearing enable bit, TMR0IE (INTCON<5>). Interrupt priority for Timer0 is determined by the value contained in the interrupt priority bit, TMR0IP (INTCON2<2>). See **Section 11.0 “Timer0 Module”** for further details on the Timer0 module.

9.8 PORTB Interrupt-on-Change

An input change on PORTB<7:4> sets flag bit, RBIF (INTCON<0>). The interrupt can be enabled/disabled by setting/clearing enable bit, RBIE (INTCON<3>). Interrupt priority for PORTB interrupt-on-change is determined by the value contained in the interrupt priority bit, RBIP (INTCON2<0>).

9.9 Context Saving During Interrupts

During an interrupt, the return PC value is saved on the stack. Additionally, the WREG, STATUS and BSR registers are saved on the fast return stack. If a fast return from interrupt is not used (see **Section 4.3 “Fast Register Stack”**), the user may need to save the WREG, STATUS and BSR registers in software. Depending on the user's application, other registers may also need to be saved. Example 9-1 saves and restores the WREG, STATUS and BSR registers during an Interrupt Service Routine.

EXAMPLE 9-1: SAVING STATUS, WREG AND BSR REGISTERS IN RAM

```
MOVWF  W_TEMP                ; W_TEMP is in virtual bank
MOVFF  STATUS, STATUS_TEMP   ; STATUS_TEMP located anywhere
MOVFF  BSR, BSR_TEMP         ; BSR located anywhere
;
; USER ISR CODE
;
MOVFF  BSR_TEMP, BSR        ; Restore BSR
MOVF   W_TEMP, W            ; Restore WREG
MOVFF  STATUS_TEMP, STATUS  ; Restore STATUS
```

10.0 I/O PORTS

Depending on the device selected, there are either seven or nine I/O ports available on PIC18F6525/6621/8525/8621 devices. Some of their pins are multiplexed with one or more alternate functions from the other peripheral features on the device. In general, when a peripheral is enabled, that pin may not be used as a general purpose I/O pin.

Each port has three registers for its operation. These registers are:

- TRIS register (data direction register)
- PORT register (reads the levels on the pins of the device)
- LAT register (output latch register)

The Data Latch (LAT) register is useful for read-modify-write operations on the value that the I/O pins are driving.

A simplified version of a generic I/O port and its operation is shown in Figure 10-1.

FIGURE 10-1: SIMPLIFIED BLOCK DIAGRAM OF PORT/LAT/ TRIS OPERATION

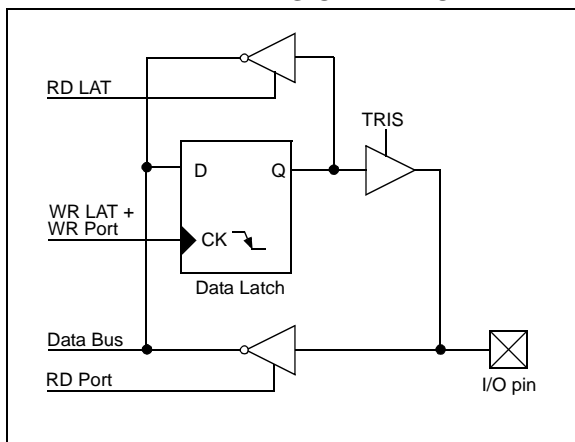

10.1 PORTA, TRISA and LATA Registers

PORTA is a 7-bit wide, bidirectional port. The corresponding data direction register is TRISA. Setting a TRISA bit (= 1) will make the corresponding PORTA pin an input (i.e., put the corresponding output driver in a high-impedance mode). Clearing a TRISA bit (= 0) will make the corresponding PORTA pin an output (i.e., put the contents of the output latch on the selected pin).

Reading the PORTA register reads the status of the pins, whereas writing to it will write to the port latch.

The Data Latch register (LATA) is also memory mapped. Read-modify-write operations on the LATA register, read and write the latched output value for PORTA.

The RA4 pin is multiplexed with the Timer0 module clock input to become the RA4/T0CKI pin. The RA4/T0CKI pin is a Schmitt Trigger input and an open-drain output. All other RA port pins have TTL input levels and full CMOS output drivers.

The RA6 pin is only enabled as a general I/O pin in ECIO and RCIO Oscillator modes.

The other PORTA pins are multiplexed with analog inputs and the analog VREF+ and VREF- inputs. The operation of each pin is selected by clearing/setting the control bits in the ADCON1 register (A/D Control Register 1).

Note: On a Power-on Reset, RA5 and RA3:RA0 are configured as analog inputs and read as '0'. RA6 and RA4 are configured as digital inputs.

The TRISA register controls the direction of the RA pins even when they are being used as analog inputs. The user must ensure the bits in the TRISA register are maintained set when using them as analog inputs.

EXAMPLE 10-1: INITIALIZING PORTA

```

CLRWF  PORTA  ; Initialize PORTA by
              ; clearing output
              ; data latches
CLRWF  LATA   ; Alternate method
              ; to clear output
              ; data latches
MOVLW  0x0F  ; Configure A/D
MOVWF  ADCON1 ; for digital inputs
MOVLW  0x0F  ; Value used to
              ; initialize data
              ; direction
MOVWF  TRISA  ; Set RA<3:0> as inputs
              ; RA<6:4> as outputs
    
```

PIC18F6525/6621/8525/8621

FIGURE 10-2: BLOCK DIAGRAM OF RA3:RA0 AND RA5 PINS

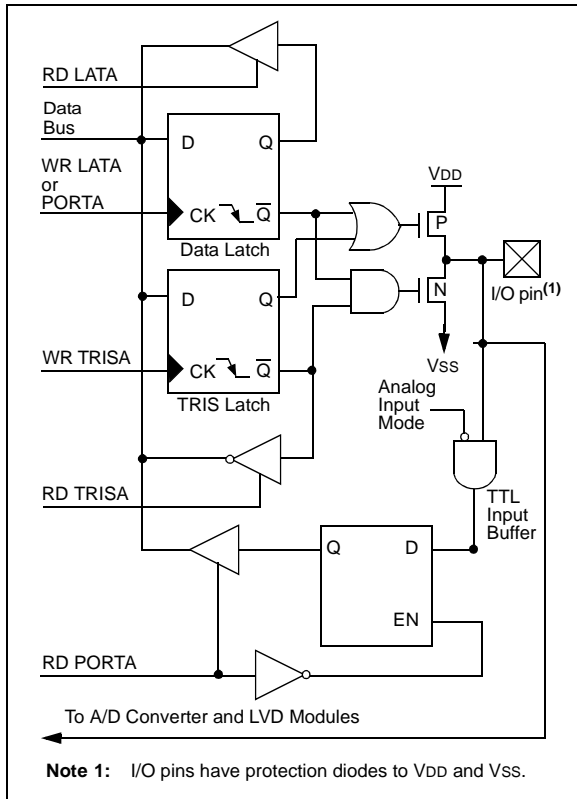

FIGURE 10-3: BLOCK DIAGRAM OF RA4/T0CKI PIN

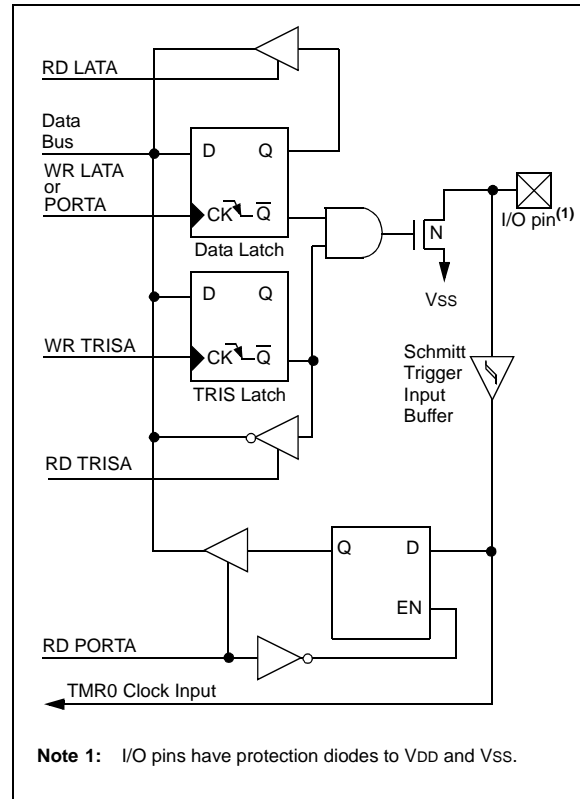
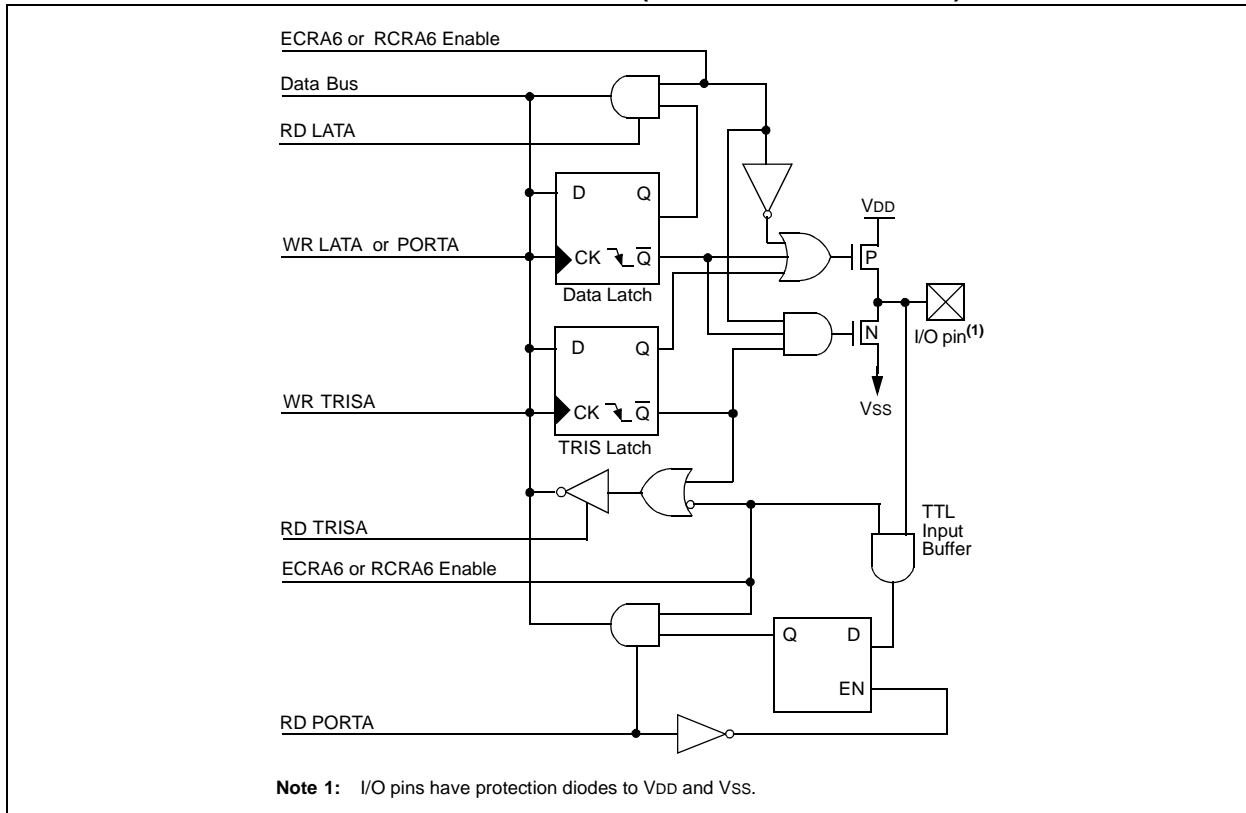

FIGURE 10-4: BLOCK DIAGRAM OF RA6 PIN (WHEN ENABLED AS I/O)



PIC18F6525/6621/8525/8621

TABLE 10-1: PORTA FUNCTIONS

Name	Bit#	Buffer	Function
RA0/AN0	bit 0	TTL	Input/output or analog input.
RA1/AN1	bit 1	TTL	Input/output or analog input.
RA2/AN2/VREF-	bit 2	TTL	Input/output, analog input or VREF-.
RA3/AN3/VREF+	bit 3	TTL	Input/output, analog input or VREF+.
RA4/T0CKI	bit 4	ST	Input/output or external clock input for Timer0. Output is open-drain type.
RA5/AN4/LVDIN	bit 5	TTL	Input/output, analog input or Low-Voltage Detect input.
OSC2/CLKO/RA6	bit 6	TTL	OSC2, clock output or I/O pin

Legend: TTL = TTL input, ST = Schmitt Trigger input

TABLE 10-2: SUMMARY OF REGISTERS ASSOCIATED WITH PORTA

Name	Bit 7	Bit 6	Bit 5	Bit 4	Bit 3	Bit 2	Bit 1	Bit 0	Value on POR, BOR	Value on all other Resets
PORTA	—	RA6 ⁽¹⁾	RA5	RA4	RA3	RA2	RA1	RA0	-x0x 0000	-u0u 0000
LATA	—	LATA6 ⁽¹⁾	LATA Data Output Register						-xxx xxxx	-uuu uuuu
TRISA	—	TRISA6 ⁽¹⁾	PORTA Data Direction Register						-111 1111	-111 1111
ADCON1	—	—	VCFG1	VCFG0	PCFG3	PCFG2	PCFG1	PCFG0	--00 0000	--00 0000

Legend: x = unknown, u = unchanged, — = unimplemented locations read as '0'.
Shaded cells are not used by PORTA.

Note 1: RA6 and associated bits are configured as port pins in RCIO and ECIO Oscillator modes only and read '0' in all other oscillator modes.

PIC18F6525/6621/8525/8621

10.2 PORTB, TRISB and LATB Registers

PORTB is an 8-bit wide, bidirectional port. The corresponding data direction register is TRISB. Setting a TRISB bit (= 1) will make the corresponding PORTB pin an input (i.e., put the corresponding output driver in a high-impedance mode). Clearing a TRISB bit (= 0) will make the corresponding PORTB pin an output (i.e., put the contents of the output latch on the selected pin).

The Data Latch register (LATB) is also memory mapped. Read-modify-write operations on the LATB register, read and write the latched output value for PORTB.

EXAMPLE 10-2: INITIALIZING PORTB

```

CLRF   PORTB   ; Initialize PORTB by
                ; clearing output
                ; data latches

CLRF   LATB    ; Alternate method
                ; to clear output
                ; data latches

MOVLW  0xCF    ; Value used to
                ; initialize data
                ; direction

MOVWF  TRISB   ; Set RB<3:0> as inputs
                ; RB<5:4> as outputs
                ; RB<7:6> as inputs
    
```

Each of the PORTB pins has a weak internal pull-up. A single control bit can turn on all the pull-ups. This is performed by clearing bit $\overline{\text{RBPU}}$ (INTCON2<7>). The weak pull-up is automatically turned off when the port pin is configured as an output. The pull-ups are disabled on a Power-on Reset.

Note: On a Power-on Reset, these pins are configured as digital inputs.

Four of the PORTB pins (RB3:RB0) are the external interrupt pins, INT3 through INT0. In order to use these pins as external interrupts, the corresponding TRISB bit must be set to '1'.

The other four PORTB pins (RB7:RB4) have an interrupt-on-change feature. Only pins configured as inputs can cause this interrupt to occur (i.e., any RB7:RB4 pin configured as an output is excluded from the interrupt-on-change comparison). The input pins (of RB7:RB4) are compared with the old value latched on the last read of PORTB. The "mismatch" outputs of RB7:RB4 are ORed together to generate the RB Port Change Interrupt with Flag bit, RBIF (INTCON<0>).

This interrupt can wake the device from Sleep. The user, in the Interrupt Service Routine, can clear the interrupt in the following manner:

- Any read or write of PORTB (except with the MOVFF instruction).
- Clear flag bit RBIF.

A mismatch condition will continue to set flag bit, RBIF. Reading PORTB will end the mismatch condition and allow flag bit RBIF to be cleared.

The interrupt-on-change feature is recommended for wake-up on key depression operation and operations where PORTB is only used for the interrupt-on-change feature. Polling of PORTB is not recommended while using the interrupt-on-change feature.

For PIC18F8525/8621 devices, RB3 can be configured by the configuration bit, CCP2MX, as the alternate peripheral pin for the ECCP2 module. This is only available when the device is configured in Microprocessor, Microprocessor with Boot Block or Extended Microcontroller operating modes.

The RB5 pin is used as the LVP programming pin. When the LVP configuration bit is programmed, this pin loses the I/O function and becomes a programming test function.

Note: When LVP is enabled, the weak pull-up on RB5 is disabled.

FIGURE 10-5: BLOCK DIAGRAM OF RB7:RB4 PINS

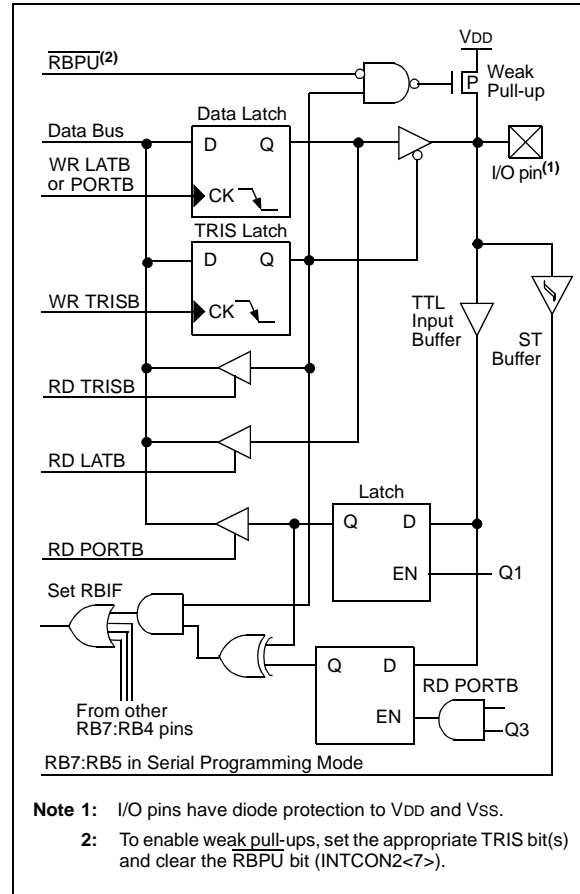

- Note 1:** I/O pins have diode protection to VDD and VSS.
Note 2: To enable weak pull-ups, set the appropriate TRIS bit(s) and clear the RBPU bit (INTCON2<7>).

PIC18F6525/6621/8525/8621

FIGURE 10-6: BLOCK DIAGRAM OF RB2:RB0 PINS

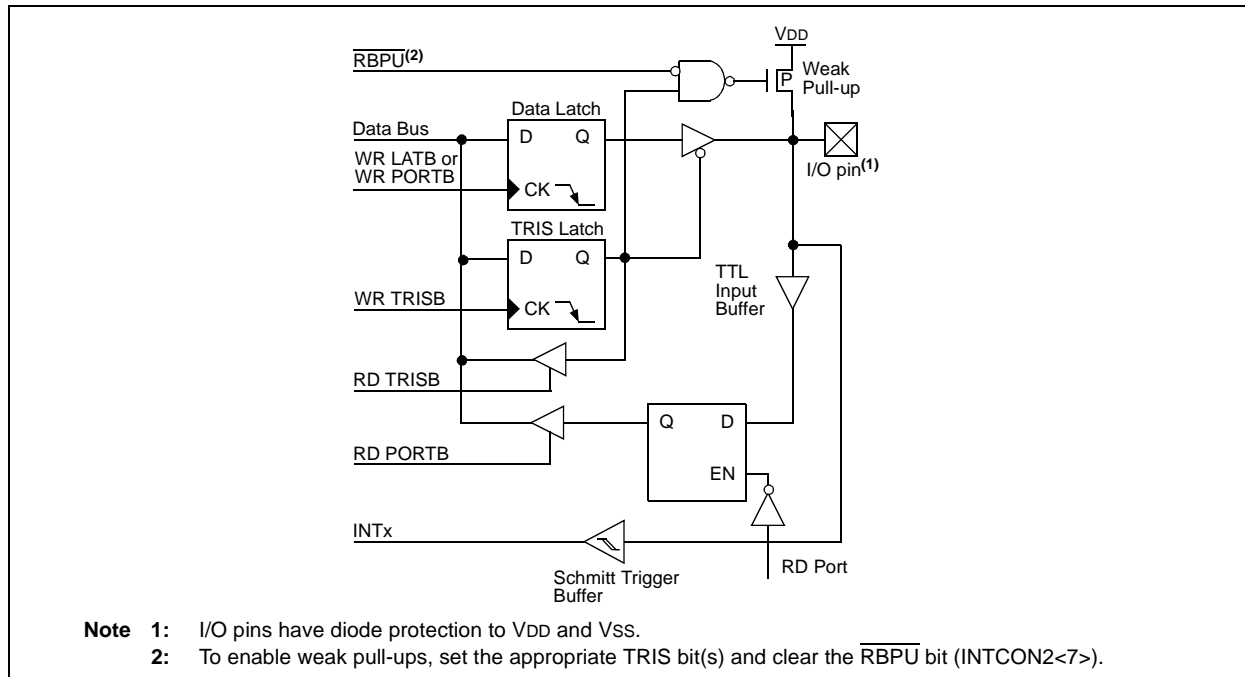
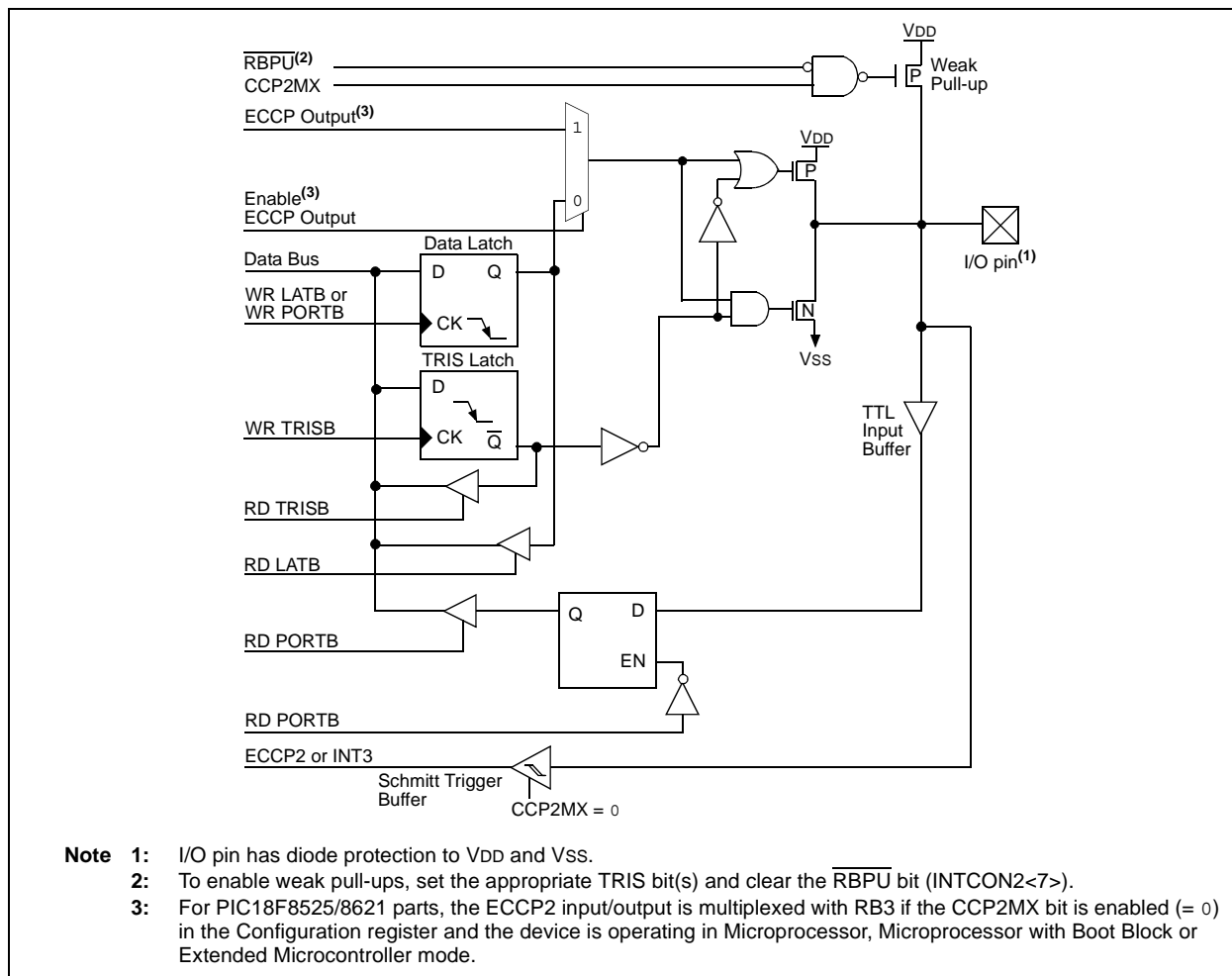

FIGURE 10-7: BLOCK DIAGRAM OF RB3 PIN



PIC18F6525/6621/8525/8621

TABLE 10-3: PORTB FUNCTIONS

Name	Bit#	Buffer	Function
RB0/INT0/FLT0	bit 0	TTL/ST ⁽¹⁾	Input/output pin or external interrupt input 0, ECCP1 PWM Fault input. Internal software programmable weak pull-up.
RB1/INT1	bit 1	TTL/ST ⁽¹⁾	Input/output pin or external interrupt input 1. Internal software programmable weak pull-up.
RB2/INT2	bit 2	TTL/ST ⁽¹⁾	Input/output pin or external interrupt input 2. Internal software programmable weak pull-up.
RB3/INT3/ ECCP2 ⁽³⁾ /P2A ⁽³⁾	bit 3	TTL/ST ⁽⁴⁾	Input/output pin, external interrupt input 3, Enhanced Capture 2 input/ Compare 2 output/PWM 2 output or Enhanced PWM output P2A. Internal software programmable weak pull-up.
RB4/KBI0	bit 4	TTL	Input/output pin (with interrupt-on-change). Internal software programmable weak pull-up.
RB5/KBI1/PGM	bit 5	TTL/ST ⁽²⁾	Input/output pin (with interrupt-on-change). Internal software programmable weak pull-up. Low-Voltage ICSP™ enable pin.
RB6/KBI2/PGC	bit 6	TTL/ST ⁽²⁾	Input/output pin (with interrupt-on-change). Internal software programmable weak pull-up. Serial programming clock.
RB7/KBI3/PGD	bit 7	TTL/ST ⁽²⁾	Input/output pin (with interrupt-on-change). Internal software programmable weak pull-up. Serial programming data.

Legend: TTL = TTL input, ST = Schmitt Trigger input

Note 1: This buffer is a Schmitt Trigger input when configured as the external interrupt.

2: This buffer is a Schmitt Trigger input when used in Serial Programming mode.

3: Valid for PIC18F8525/8621 devices in all operating modes except Microcontroller mode when CCP2MX is not set. RC1 is the default assignment for ECCP2/PA2 when CCP2MX is set in all devices; RE7 is the alternate assignment for PIC18F8525/8621 devices in Microcontroller mode when CCP2MX is clear.

4: This buffer is a Schmitt Trigger input when configured as the ECCP2 input.

TABLE 10-4: SUMMARY OF REGISTERS ASSOCIATED WITH PORTB

Name	Bit 7	Bit 6	Bit 5	Bit 4	Bit 3	Bit 2	Bit 1	Bit 0	Value on POR, BOR	Value on all other Resets
PORTB	RB7	RB6	RB5	RB4	RB3	RB2	RB1	RB0	xxxx xxxx	uuuu uuuu
LATB	LATB Data Output Register								xxxx xxxx	uuuu uuuu
TRISB	PORTB Data Direction Register								1111 1111	1111 1111
INTCON	GIE/GIEH	PEIE/GIEL	TMR0IE	INT0IE	RBIE	TMR0IF	INT0IF	RBIF	0000 000x	0000 000u
INTCON2	$\overline{\text{RBP}}\text{U}$	INTEDG0	INTEDG1	INTEDG2	INTEDG3	TMR0IP	INT3IP	RBIP	1111 1111	1111 1111
INTCON3	INT2IP	INT1IP	INT3IE	INT2IE	INT1IE	INT3IF	INT2IF	INT1IF	1100 0000	1100 0000

Legend: x = unknown, u = unchanged. Shaded cells are not used by PORTB.

PIC18F6525/6621/8525/8621

10.3 PORTC, TRISC and LATC Registers

PORTC is an 8-bit wide, bidirectional port. The corresponding data direction register is TRISC. Setting a TRISC bit (= 1) will make the corresponding PORTC pin an input (i.e., put the corresponding output driver in a high-impedance mode). Clearing a TRISC bit (= 0) will make the corresponding PORTC pin an output (i.e., put the contents of the output latch on the selected pin).

The Data Latch register (LATC) is also memory mapped. Read-modify-write operations on the LATC register, read and write the latched output value for PORTC.

PORTC is multiplexed with several peripheral functions (Table 10-5). PORTC pins have Schmitt Trigger input buffers.

When enabling peripheral functions, care should be taken in defining TRIS bits for each PORTC pin. Some peripherals override the TRIS bit to make a pin an output, while other peripherals override the TRIS bit to make a pin an input. The user should refer to the corresponding peripheral section for the correct TRIS bit settings.

Note: On a Power-on Reset, these pins are configured as digital inputs.

The pin override value is not loaded into the TRIS register. This allows read-modify-write of the TRIS register without concern due to peripheral overrides.

RC1 is normally configured by configuration bit, CCP2MX, as the default peripheral pin of the ECCP2 module (default/erased state, CCP2MX = 1).

EXAMPLE 10-3: INITIALIZING PORTC

```
CLRF    PORTC    ; Initialize PORTC by
                ; clearing output
                ; data latches
CLRF    LATC     ; Alternate method
                ; to clear output
                ; data latches
MOVLW  0xCF     ; Value used to
                ; initialize data
                ; direction
MOVWF  TRISC    ; Set RC<3:0> as inputs
                ; RC<5:4> as outputs
                ; RC<7:6> as inputs
```

FIGURE 10-8: PORTC BLOCK DIAGRAM (PERIPHERAL OUTPUT OVERRIDE)

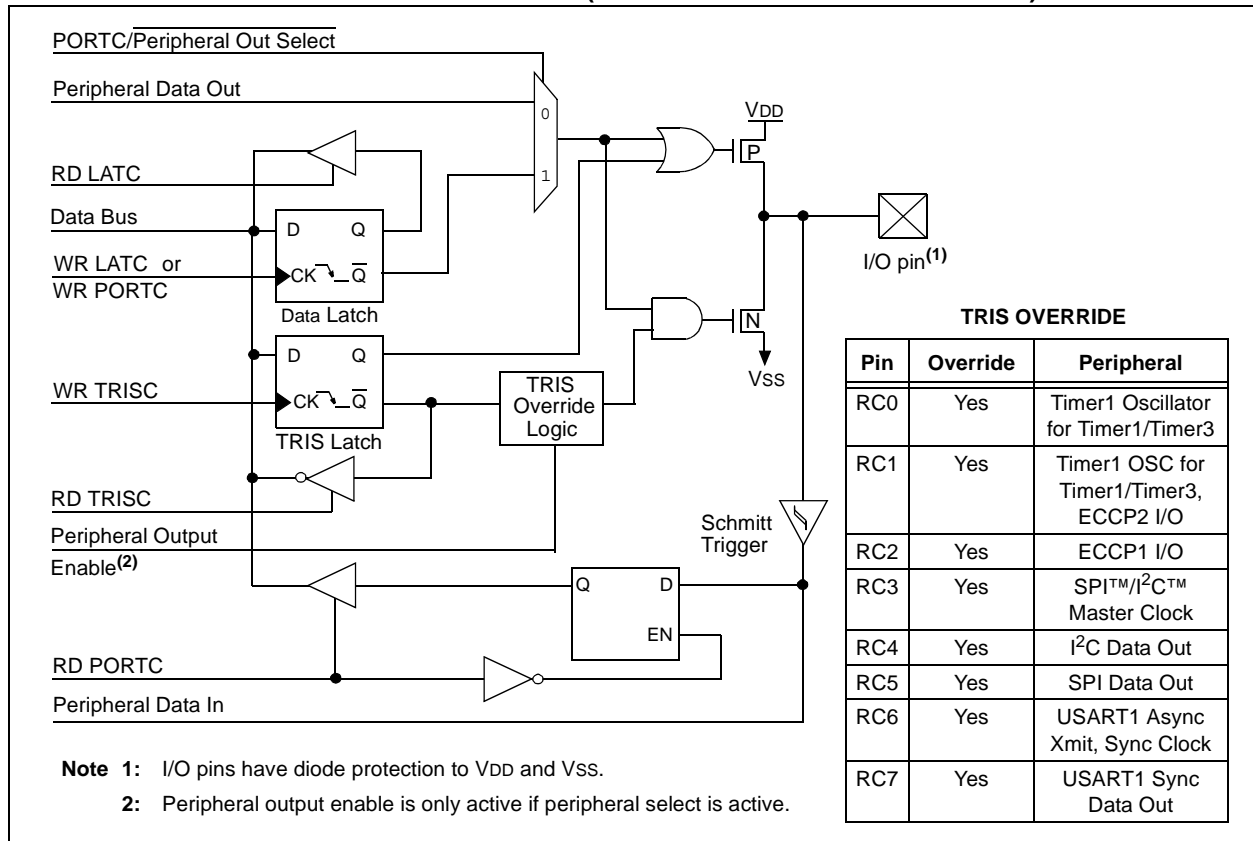

PIC18F6525/6621/8525/8621

TABLE 10-5: PORTC FUNCTIONS

Name	Bit#	Buffer Type	Function
RC0/T1OSO/T13CKI	bit 0	ST	Input/output port pin, Timer1 oscillator output or Timer1/Timer3 clock input.
RC1/T1OSI/ ECCP2 ⁽¹⁾ /P2A ⁽¹⁾	bit 1	ST	Input/output port pin, Timer1 oscillator input, Enhanced Capture 2 input/Compare 2 output/PWM 2 output or Enhanced PWM output P2A.
RC2/ECCP1/P1A	bit 2	ST	Input/output port pin, Enhanced Capture 1 input/Compare 1 output/PWM 1 output or Enhanced PWM output P1A.
RC3/SCK/SCL	bit 3	ST	RC3 can also be the synchronous serial clock for both SPI™ and I ² C™ modes.
RC4/SDI/SDA	bit 4	ST	RC4 can also be the SPI data in (SPI mode) or data I/O (I ² C mode).
RC5/SDO	bit 5	ST	Input/output port pin or synchronous serial port data output.
RC6/TX1/CK1	bit 6	ST	Input/output port pin, Addressable USART1 Asynchronous Transmit or Addressable USART1 Synchronous Clock.
RC7/RX1/DT1	bit 7	ST	Input/output port pin, Addressable USART1 Asynchronous Receive or Addressable USART1 Synchronous Data.

Legend: ST = Schmitt Trigger input

Note 1: Valid when CCP2MX is set in all devices and in all operating modes (default). RE7 is the alternate assignment for ECCP2/P2A for all PIC18F6525/6621 devices and PIC18F8525/8621 devices in Microcontroller modes when CCP2MX is not set; RB3 is the alternate assignment for PIC18F8525/8621 devices in all other operating modes.

TABLE 10-6: SUMMARY OF REGISTERS ASSOCIATED WITH PORTC

Name	Bit 7	Bit 6	Bit 5	Bit 4	Bit 3	Bit 2	Bit 1	Bit 0	Value on POR, BOR	Value on all other Resets
PORTC	RC7	RC6	RC5	RC4	RC3	RC2	RC1	RC0	xxxx xxxx	uuuu uuuu
LATC	LATC Data Output Register								xxxx xxxx	uuuu uuuu
TRISC	PORTC Data Direction Register								1111 1111	1111 1111

Legend: x = unknown, u = unchanged

10.4 PORTD, TRISD and LATD Registers

PORTD is an 8-bit wide, bidirectional port. The corresponding data direction register is TRISD. Setting a TRISD bit (= 1) will make the corresponding PORTD pin an input (i.e., put the corresponding output driver in a high-impedance mode). Clearing a TRISD bit (= 0) will make the corresponding PORTD pin an output (i.e., put the contents of the output latch on the selected pin).

The Data Latch register (LATD) is also memory mapped. Read-modify-write operations on the LATD register, read and write the latched output value for PORTD.

PORTD is an 8-bit port with Schmitt Trigger input buffers. Each pin is individually configurable as an input or output.

Note: On a Power-on Reset, these pins are configured as digital inputs.

PORTD is multiplexed with the system bus as the external memory interface. I/O port functions are only available when the system bus is disabled by setting the EBDIS bit in the MEMCOM register (MEMCON<7>). When operating as the external memory interface, PORTD is the low-order byte of the multiplexed address/data bus (AD7:AD0).

PORTD can also be configured as an 8-bit wide microprocessor port (Parallel Slave Port) by setting control bit PSMODE (TRISE<4>). In this mode, the input buffers are TTL. See **Section 10.10 “Parallel Slave Port”** for additional information on the Parallel Slave Port (PSP).

EXAMPLE 10-4: INITIALIZING PORTD

```

CLRFB   PORTD   ; Initialize PORTD by
                ; clearing output
                ; data latches
CLRFB   LATD    ; Alternate method
                ; to clear output
                ; data latches
MOVLW   0xCF    ; Value used to
                ; initialize data
                ; direction
MOVWF   TRISD   ; Set RD<3:0> as inputs
                ; RD<5:4> as outputs
                ; RD<7:6> as inputs
    
```

FIGURE 10-9: PORTD BLOCK DIAGRAM IN I/O PORT MODE

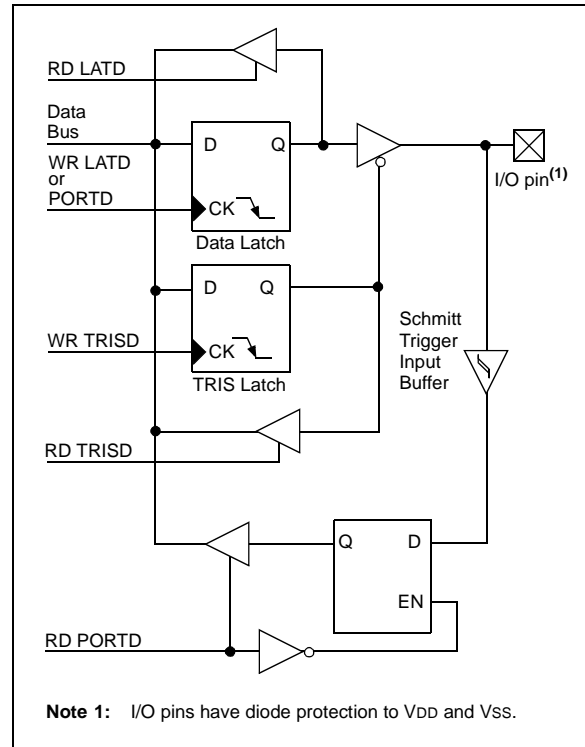

PIC18F6525/6621/8525/8621

FIGURE 10-10: PORTD BLOCK DIAGRAM IN SYSTEM BUS MODE

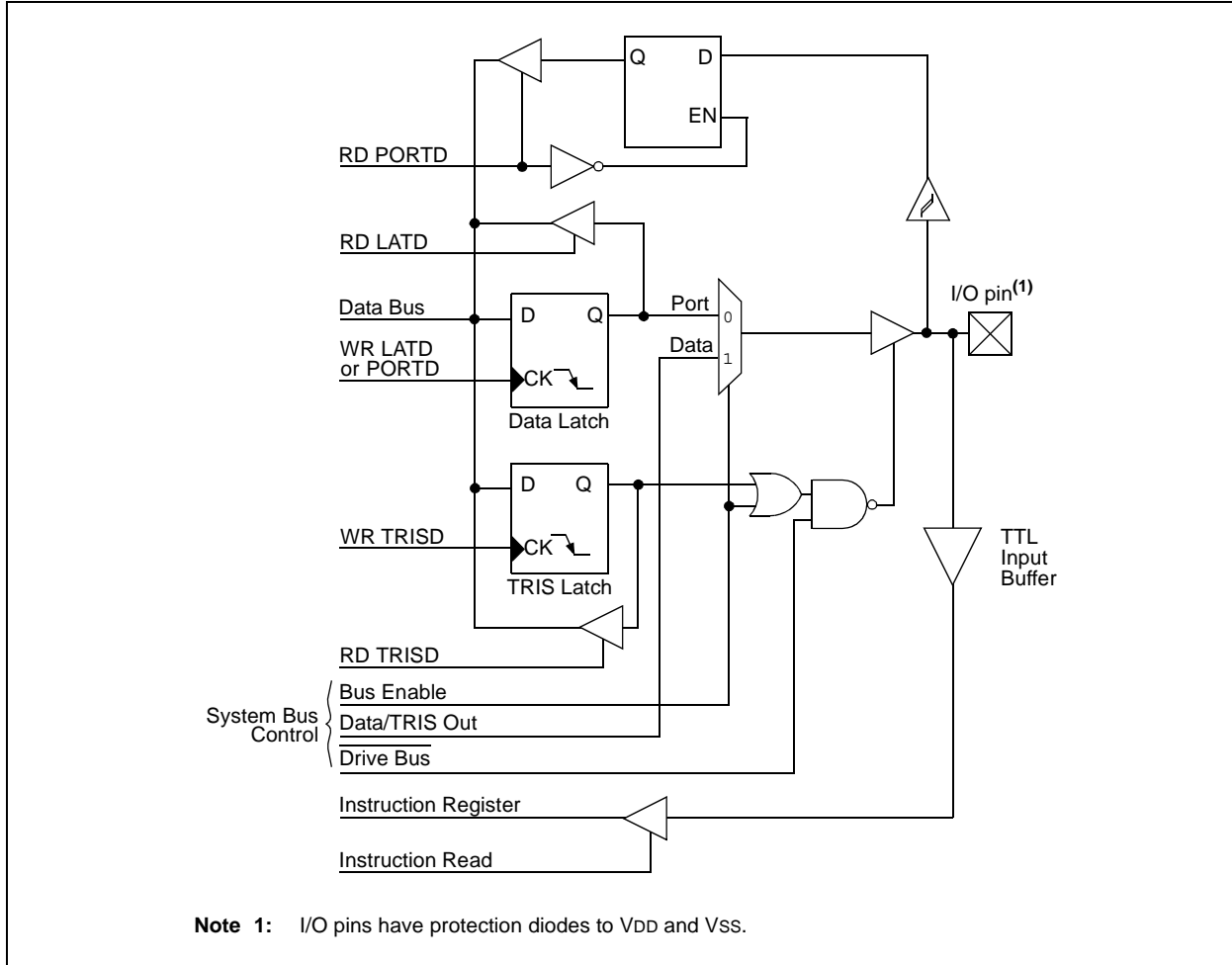

PIC18F6525/6621/8525/8621

TABLE 10-7: PORTD FUNCTIONS

Name	Bit#	Buffer Type	Function
RD0/AD0 ⁽²⁾ /PSP0	bit 0	ST/TTL ⁽¹⁾	Input/output port pin, address/data bus bit 0 or Parallel Slave Port bit 0.
RD1/AD1 ⁽²⁾ /PSP1	bit 1	ST/TTL ⁽¹⁾	Input/output port pin, address/data bus bit 1 or Parallel Slave Port bit 1.
RD2/AD2 ⁽²⁾ /PSP2	bit 2	ST/TTL ⁽¹⁾	Input/output port pin, address/data bus bit 2 or Parallel Slave Port bit 2.
RD3/AD3 ⁽²⁾ /PSP3	bit 3	ST/TTL ⁽¹⁾	Input/output port pin, address/data bus bit 3 or Parallel Slave Port bit 3.
RD4/AD4 ⁽²⁾ /PSP4	bit 4	ST/TTL ⁽¹⁾	Input/output port pin, address/data bus bit 4 or Parallel Slave Port bit 4.
RD5/AD5 ⁽²⁾ /PSP5	bit 5	ST/TTL ⁽¹⁾	Input/output port pin, address/data bus bit 5 or Parallel Slave Port bit 5.
RD6/AD6 ⁽²⁾ /PSP6	bit 6	ST/TTL ⁽¹⁾	Input/output port pin, address/data bus bit 6 or Parallel Slave Port bit 6.
RD7/AD7 ⁽²⁾ /PSP7	bit 7	ST/TTL ⁽¹⁾	Input/output port pin, address/data bus bit 7 or Parallel Slave Port bit 7.

Legend: ST = Schmitt Trigger input, TTL = TTL input

Note 1: Input buffers are Schmitt Triggers when in I/O mode and TTL buffers when in System Bus or Parallel Slave Port mode.

2: External memory interface functions are only available on PIC18F8525/8621 devices.

TABLE 10-8: SUMMARY OF REGISTERS ASSOCIATED WITH PORTD

Name	Bit 7	Bit 6	Bit 5	Bit 4	Bit 3	Bit 2	Bit 1	Bit 0	Value on POR, BOR	Value on all other Resets
PORTD	RD7	RD6	RD5	RD4	RD3	RD2	RD1	RD0	xxxx xxxx	uuuu uuuu
LATD	LATD Data Output Register								xxxx xxxx	uuuu uuuu
TRISD	PORTD Data Direction Register								1111 1111	1111 1111
PSPCON ⁽¹⁾	IBF	OBF	IBOV	PSPMODE	—	—	—	—	0000 ----	0000 ----
MEMCON ⁽²⁾	EBDIS	—	WAIT1	WAIT0	—	—	WM1	WM0	0-00 --00	0-00 --00

Legend: x = unknown, u = unchanged, — = unimplemented, read as '0'. Shaded cells are not used by PORTD.

Note 1: Enabled only in Microcontroller mode for PIC18F8525/8621 devices.

2: This register is unused on PIC18F6525/6621 devices and reads as '0'.

PIC18F6525/6621/8525/8621

10.5 PORTE, TRISE and LATE Registers

PORTE is an 8-bit wide, bidirectional port. The corresponding data direction register is TRISE. Setting a TRISE bit (= 1) will make the corresponding PORTE pin an input (i.e., put the corresponding output driver in a high-impedance mode). Clearing a TRISE bit (= 0) will make the corresponding PORTE pin an output (i.e., put the contents of the output latch on the selected pin).

Read-modify-write operations on the LATE register, read and write the latched output value for PORTE.

PORTE is an 8-bit port with Schmitt Trigger input buffers. Each pin is individually configurable as an input or output. PORTE is multiplexed with the ECCP module (Table 10-9).

On PIC18F8525/8621 devices, PORTE is also multiplexed with the system bus as the external memory interface; the I/O bus is available only when the system bus is disabled by setting the EBDIS bit in the MEMCON register (MEMCON<7>). If the device is configured in Microprocessor or Extended Microcontroller mode, then the PORTE<7:0> becomes the high byte of the address/data bus for the external program memory interface. In Microcontroller mode, the PORTE<2:0> pins become the control inputs for the Parallel Slave Port when bit PSPMODE (PSPCON<4>) is set. (Refer to **Section 4.1.1 “PIC18F6525/6621/8525/8621 Program Memory Modes”** for more information.)

When the Parallel Slave Port is active, three PORTE pins (RE0/AD8/RD/P2D, RE1/AD9/WR/P2C and RE2/AD10/CS/P2B) function as its control inputs. This automatically occurs when the PSPMODE bit (PSPCON<4>) is set. Users must also make certain that bits TRISE<2:0> are set to configure the pins as digital inputs and the ADCON1 register is configured for digital I/O. The PORTE PSP control functions are summarized in Table 10-9.

Pin RE7 can be configured as the alternate peripheral pin for the ECCP2 module when the device is operating in Microcontroller mode. This is done by clearing the configuration bit, CCP2MX, in the CONFIG3H Configuration register (CONFIG3H<0>).

Note: For PIC18F8525/8621 (80-pin) devices operating in Extended Microcontroller mode, PORTE defaults to the system bus on Power-on Reset.

EXAMPLE 10-5: INITIALIZING PORTE

```
CLRF   PORTE   ; Initialize PORTE by
           ; clearing output
           ; data latches
CLRF   LATE    ; Alternate method
           ; to clear output
           ; data latches
MOVLW  0x03   ; Value used to
           ; initialize data
           ; direction
MOVWF  TRISE   ; Set RE1:RE0 as inputs
           ; RE7:RE2 as outputs
```

PIC18F6525/6621/8525/8621

FIGURE 10-11: PORTE BLOCK DIAGRAM IN I/O MODE

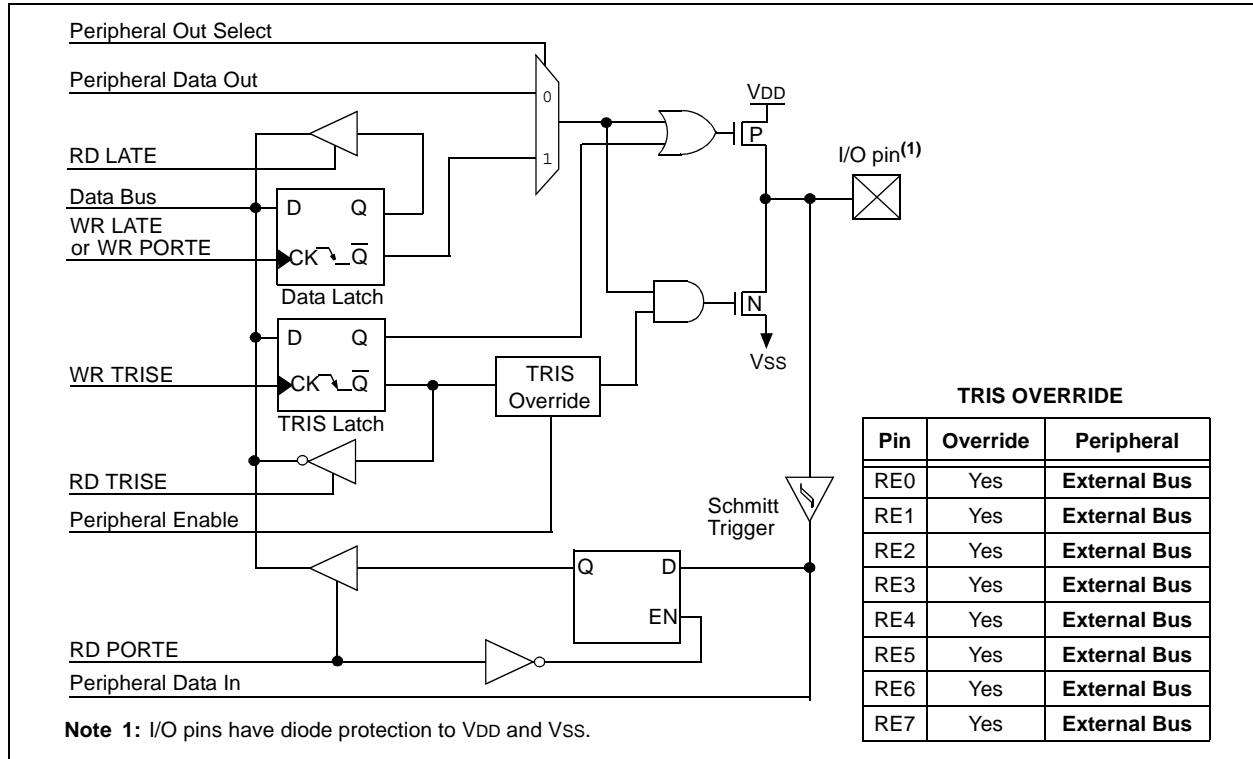
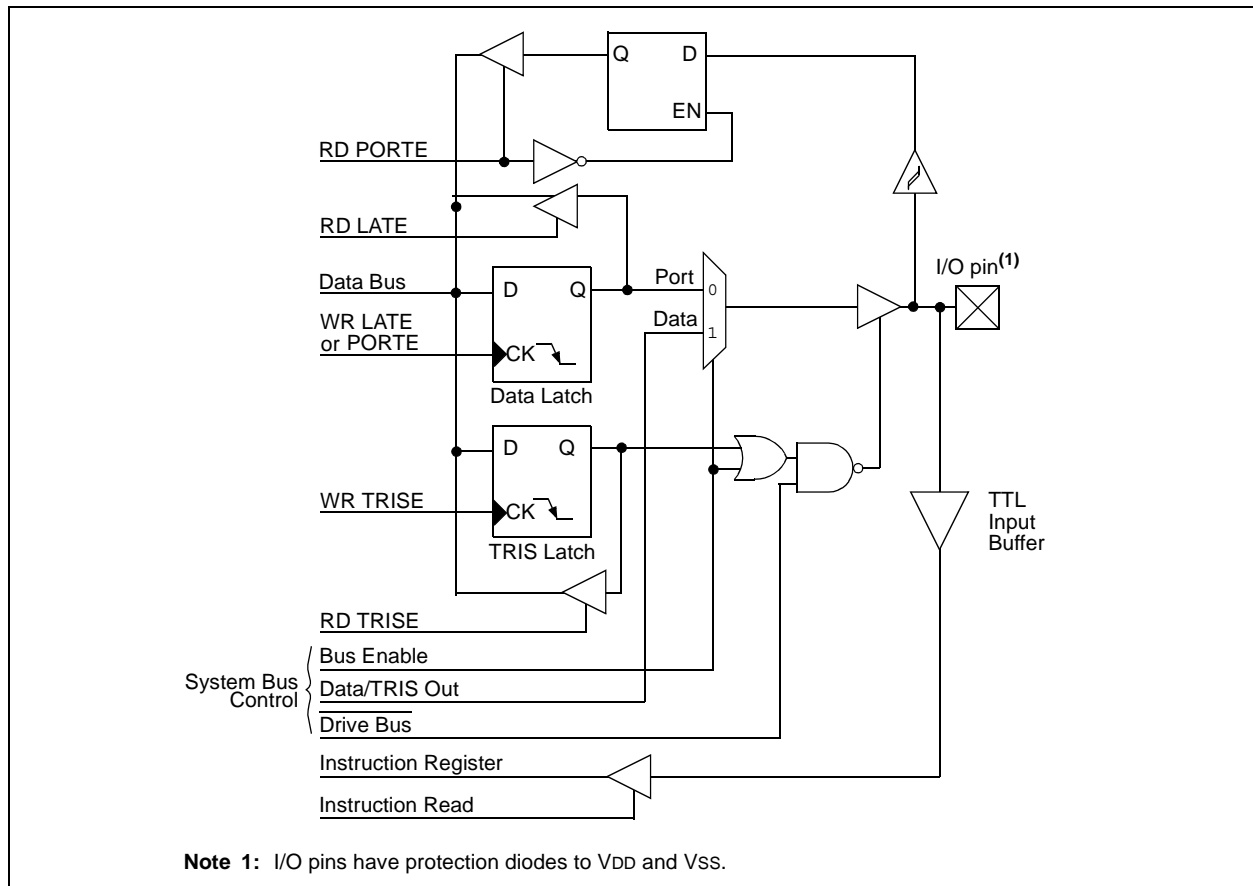

FIGURE 10-12: PORTE BLOCK DIAGRAM IN SYSTEM BUS MODE



PIC18F6525/6621/8525/8621

TABLE 10-9: PORTE FUNCTIONS

Name	Bit#	Buffer Type	Function
RE0/AD8/ \overline{RD} /P2D	bit 0	ST/TTL ⁽¹⁾	Input/output port pin, address/data bit 8, read control for Parallel Slave Port or Enhanced PWM 2 output P2D For \overline{RD} (PSP Control mode): 1 = Not a read operation 0 = Read operation, reads PORTD register (if chip selected)
RE1/AD9/ \overline{WR} /P2C	bit 1	ST/TTL ⁽¹⁾	Input/output port pin, address/data bit 9, write control for Parallel Slave Port or Enhanced PWM 2 output P2C For \overline{WR} (PSP Control mode): 1 = Not a write operation 0 = Write operation, writes PORTD register (if chip selected)
RE2/AD10/ \overline{CS} /P2B	bit 2	ST/TTL ⁽¹⁾	Input/output port pin, address/data bit 10, chip select control for Parallel Slave Port or Enhanced PWM 2 output P2B For \overline{CS} (PSP Control mode): 1 = Device is not selected 0 = Device is selected
RE3/AD11/P3C ⁽²⁾	bit 3	ST/TTL ⁽¹⁾	Input/output port pin, address/data bit 11 or Enhanced PWM 3 output P3C.
RE4/AD12/P3B ⁽²⁾	bit 4	ST/TTL ⁽¹⁾	Input/output port pin, address/data bit 12 or Enhanced PWM 3 output P3B.
RE5/AD13/P1C ⁽²⁾	bit 5	ST/TTL ⁽¹⁾	Input/output port pin, address/data bit 13 or Enhanced PWM 1 output P1C.
RE6/AD14/P1B ⁽²⁾	bit 6	ST/TTL ⁽¹⁾	Input/output port pin, address/data bit 14 or Enhanced PWM 1 output P1B.
RE7/AD15/ ECCP2 ⁽³⁾ /P2A ⁽³⁾	bit 7	ST/TTL ⁽¹⁾	Input/output port pin, address/data bit 15, Enhanced Capture 2 input/ Compare 2 output/PWM 2 output or Enhanced PWM 2 output P2A.

Legend: ST = Schmitt Trigger input, TTL = TTL input

Note 1: Input buffers are Schmitt Triggers when in I/O or CCP/ECCP modes and TTL buffers when in System Bus or PSP Control modes.

2: Valid for all PIC18F6525/6621 devices and PIC18F8525/8621 devices when ECCPMX is set. Alternate assignments for P1B/P1C/P3B/P3C are RH7, RH6, RH5 and RH4, respectively.

3: Valid for all PIC18F6525/6621 devices and PIC18F8525/8621 devices in Microcontroller mode when CCP2MX is not set. RC1 is the default assignment for ECCP2/P2A for all devices in Microcontroller mode when CCP2MX is set; RB3 is the alternate assignment for PIC18F8525/8621 devices in operating modes except Microcontroller mode when CCP2MX is not set.

TABLE 10-10: SUMMARY OF REGISTERS ASSOCIATED WITH PORTE

Name	Bit 7	Bit 6	Bit 5	Bit 4	Bit 3	Bit 2	Bit 1	Bit 0	Value on: POR, BOR	Value on all other Resets
TRISE	PORTE Data Direction Control Register								1111 1111	1111 1111
PORTE	Read PORTE pin/Write PORTE Data Latch								xxxx xxxx	uuuu uuuu
LATE	Read PORTE Data Latch/Write PORTE Data Latch								xxxx xxxx	uuuu uuuu
MEMCON ⁽¹⁾	EBDIS	—	WAIT1	WAIT0	—	—	WM1	WM0	0-00 --00	0000 --00
PSPCON ⁽²⁾	IBF	OBF	IBOV	PSPMODE	—	—	—	—	0000 ----	0000 ----

Legend: x = unknown, u = unchanged, — = unimplemented, read as '0'. Shaded cells are not used by PORTE.

Note 1: This register is unused on PIC18F6525/6621 devices and reads as '0'.

2: Enabled only in Microcontroller mode for PIC18F8525/8621 devices.

PIC18F6525/6621/8525/8621

10.6 PORTF, LATF and TRISF Registers

PORTF is an 8-bit wide, bidirectional port. The corresponding data direction register is TRISF. Setting a TRISF bit (= 1) will make the corresponding PORTF pin an input (i.e., put the corresponding output driver in a high-impedance mode). Clearing a TRISF bit (= 0) will make the corresponding PORTF pin an output (i.e., put the contents of the output latch on the selected pin).

Read-modify-write operations on the LATF register, read and write the latched output value for PORTF.

PORTF is multiplexed with several analog peripheral functions, including the A/D converter inputs and comparator inputs, outputs and voltage reference.

Note 1: On a Power-on Reset, the RF6:RF0 pins are configured as inputs and read as '0'.

2: To configure PORTF as digital I/O, turn off comparators and set ADCON1 value.

EXAMPLE 10-6: INITIALIZING PORTF

```
CLRF   PORTF   ; Initialize PORTF by
              ; clearing output
              ; data latches
CLRF   LATF    ; Alternate method
              ; to clear output
              ; data latches
MOVLW  0x07   ;
MOVWF  CMCON  ; Turn off comparators
MOVLW  0x0F   ;
MOVWF  ADCON1 ; Set PORTF as digital I/O
MOVLW  0xCF   ; Value used to
              ; initialize data
              ; direction
MOVWF  TRISF  ; Set RF3:RF0 as inputs
              ; RF5:RF4 as outputs
              ; RF7:RF6 as inputs
```

FIGURE 10-13: PORTF RF1/AN6/C2OUT, RF2/AN7/C1OUT PINS BLOCK DIAGRAM

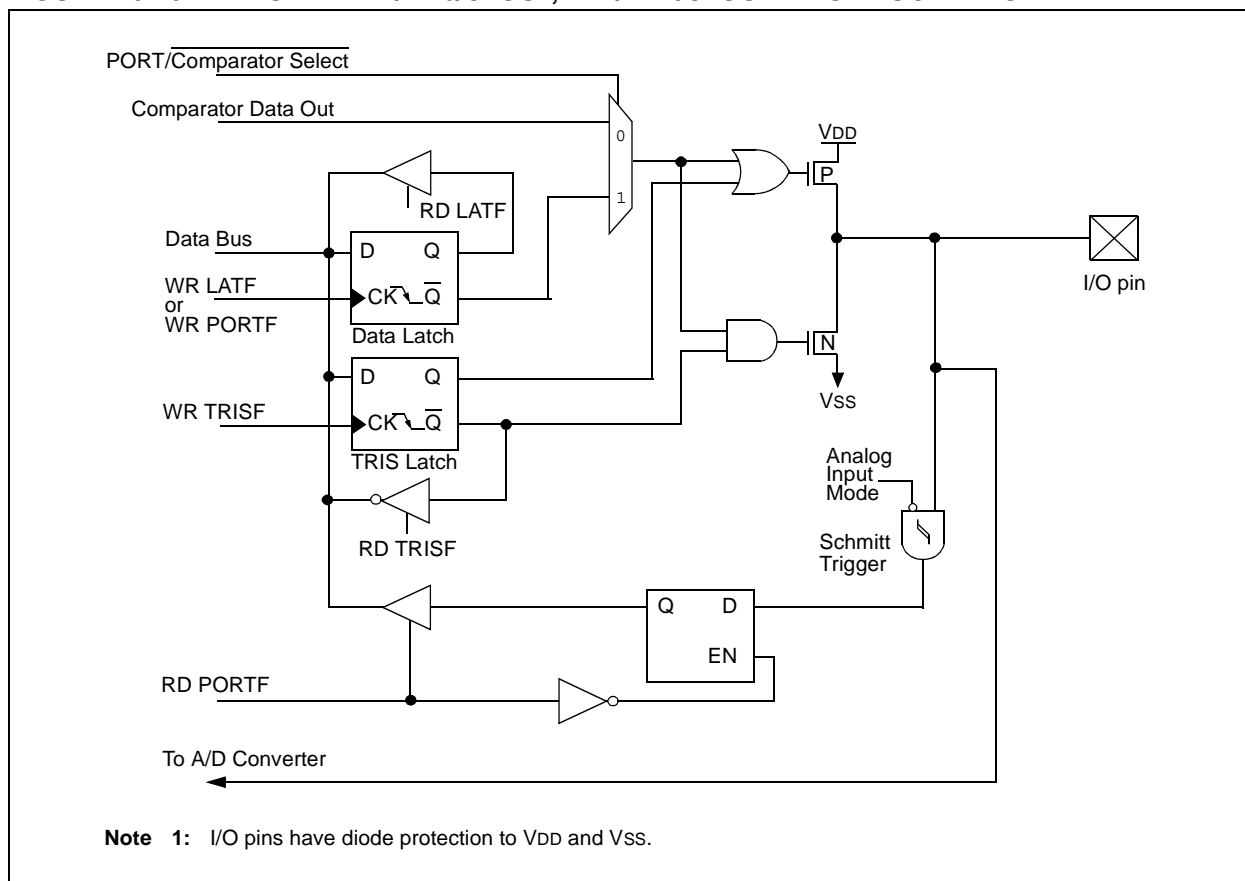

PIC18F6525/6621/8525/8621

FIGURE 10-14: RF6:RF3 AND RF0 PINS BLOCK DIAGRAM

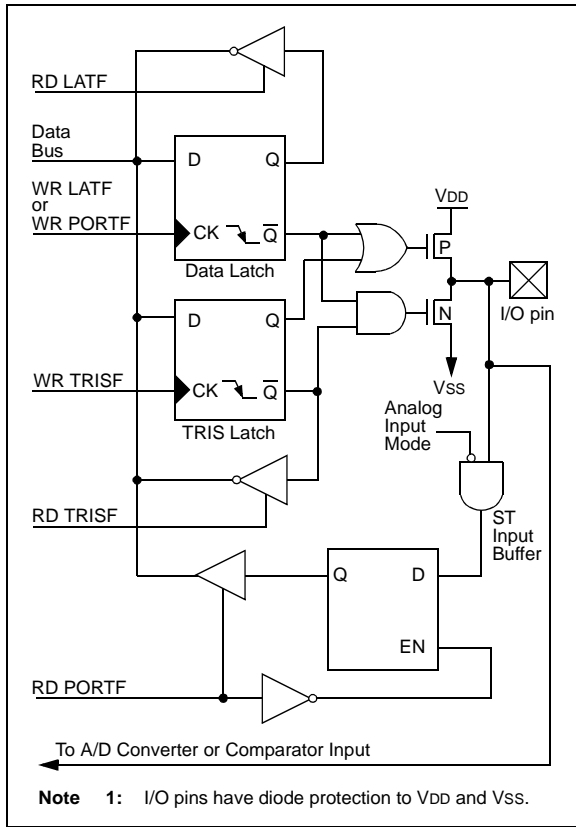
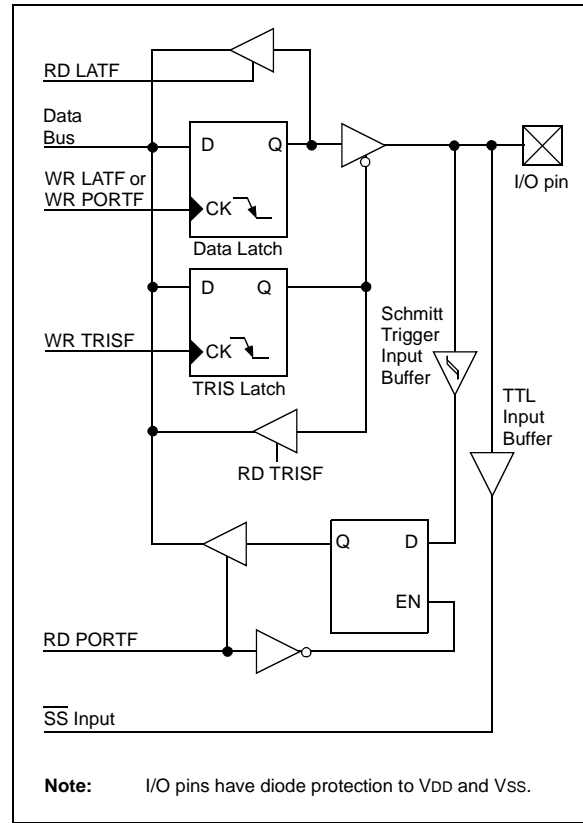

FIGURE 10-15: RF7 PIN BLOCK DIAGRAM



PIC18F6525/6621/8525/8621

TABLE 10-11: PORTF FUNCTIONS

Name	Bit#	Buffer Type	Function
RF0/AN5	bit 0	ST	Input/output port pin or analog input.
RF1/AN6/C2OUT	bit 1	ST	Input/output port pin, analog input or Comparator 2 output.
RF2/AN7/C1OUT	bit 2	ST	Input/output port pin, analog input or Comparator 1 output.
RF3/AN8	bit 3	ST	Input/output port pin or analog input/comparator input.
RF4/AN9	bit 4	ST	Input/output port pin or analog input/comparator input.
RF5/AN10/CVREF	bit 5	ST	Input/output port pin, analog input/comparator input or comparator reference output.
RF6/AN11	bit 6	ST	Input/output port pin or analog input/comparator input.
RF7/ \overline{SS}	bit 7	ST/TTL	Input/output port pin or slave select pin for synchronous serial port.

Legend: ST = Schmitt Trigger input, TTL = TTL input

TABLE 10-12: SUMMARY OF REGISTERS ASSOCIATED WITH PORTF

Name	Bit 7	Bit 6	Bit 5	Bit 4	Bit 3	Bit 2	Bit 1	Bit 0	Value on: POR, BOR	Value on all other Resets
TRISF	PORTF Data Direction Control Register								1111 1111	1111 1111
PORTF	Read PORTF pin/Write PORTF Data Latch								x000 0000	u000 0000
LATF	Read PORTF Data Latch/Write PORTF Data Latch								xxxx xxxx	uuuu uuuu
ADCON1	—	—	VCFG1	VCFG0	PCFG3	PCFG2	PCFG1	PCFG0	--00 0000	--00 0000
CMCON	C2OUT	C1OUT	C2INV	C1INV	CIS	CM2	CM1	CM0	0000 0000	0000 0000
CVRCON	CVREN	CVROE	CVRR	CVRSS	CVR3	CVR2	CVR1	CVR0	0000 0000	0000 0000

Legend: x = unknown, u = unchanged, — = unimplemented, read as '0'. Shaded cells are not used by PORTF.

PIC18F6525/6621/8525/8621

10.7 PORTG, TRISG and LATG Registers

PORTG is a 6-bit wide port with 5 bidirectional pins (RG0:RG4) and one optional input only pin (RG5). The corresponding data direction register is TRISG. Setting a TRISG bit (= 1) will make the corresponding PORTG pin an input (i.e., put the corresponding output driver in a high-impedance mode). Clearing a TRISG bit (= 0) will make the corresponding PORTG pin an output (i.e., put the contents of the output latch on the selected pin).

The Data Latch register (LATG) is also memory mapped. Read-modify-write operations on the LATG register, read and write the latched output value for PORTG.

PORTG is multiplexed with both CCP/ECCP and EUSART functions (Table 10-13). PORTG pins have Schmitt Trigger input buffers.

When enabling peripheral functions, care should be taken in defining TRIS bits for each PORTG pin. Some peripherals override the TRIS bit to make a pin an output, while other peripherals override the TRIS bit to make a pin an input. The user should refer to the corresponding peripheral section for the correct TRIS bit settings.

Note: On a Power-on Reset, these pins are configured as digital inputs.

The pin override value is not loaded into the TRIS register. This allows read-modify-write operations of the TRIS register without concern due to peripheral overrides.

The sixth pin of PORTG ($\overline{\text{MCLR}}/\text{PP}/\text{RG5}$) is a digital input pin. Its operation is controlled by the MCLRE configuration bit in Configuration Register 3H (CONFIG3H<7>). In its default configuration (MCLRE = 1), the pin functions as the device Master Clear input. When selected as a port pin (MCLRE = 0), it functions as an input only pin; as such, it does not have TRISG or LATG bits associated with it.

In either configuration, RG5 also functions as the programming voltage input during device programming.

- Note 1:** On a Power-on Reset, RG5 is enabled as a digital input only if Master Clear functionality is disabled (MCLRE = 0).
- 2:** If the device Master Clear is disabled, verify that either of the following is done to ensure proper entry into ICSP mode:
- a.) disable low-voltage programming (CONFIG4L<2> = 0); or
 - b.) make certain that RB5/KBI1/PGM is held low during entry into ICSP.

EXAMPLE 10-7: INITIALIZING PORTG

```

CLRF   PORTG   ; Initialize PORTG by
              ; clearing output
              ; data latches
CLRF   LATG    ; Alternate method
              ; to clear output
              ; data latches
MOVLW  0x04    ; Value used to
              ; initialize data
              ; direction
MOVWF  TRISG   ; Set RG1:RG0 as outputs
              ; RG2 as input
              ; RG4:RG3 as inputs
    
```

FIGURE 10-16: PORTG BLOCK DIAGRAM (PERIPHERAL OUTPUT OVERRIDE)

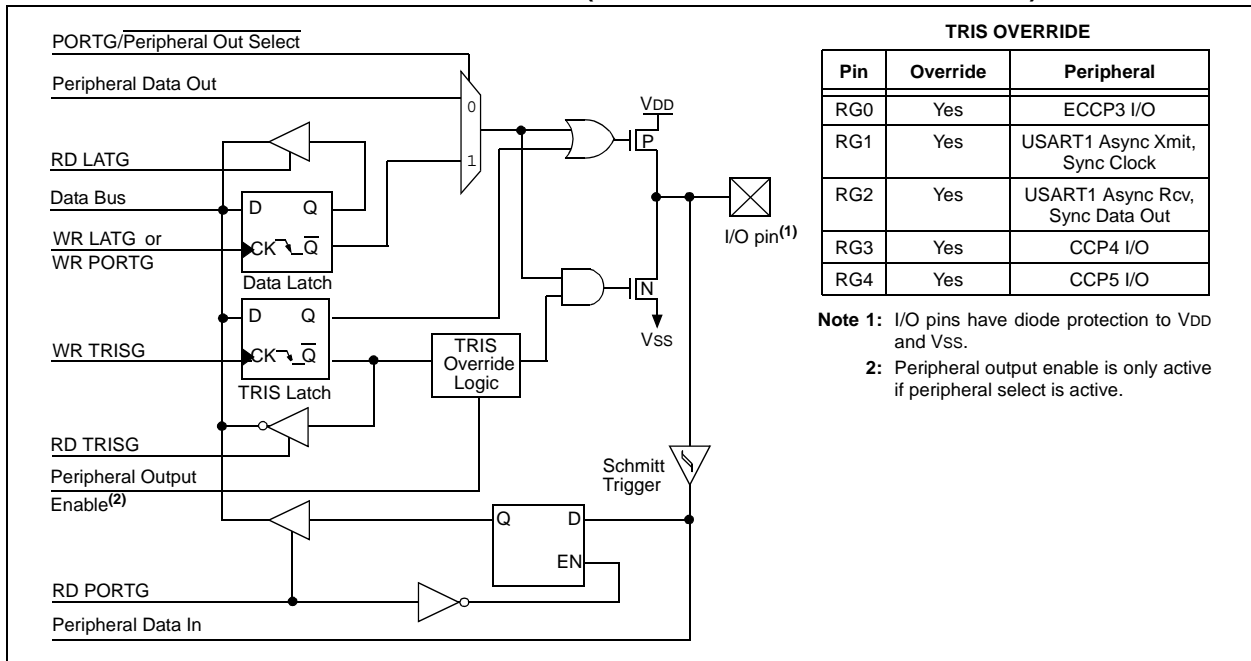

PIC18F6525/6621/8525/8621

FIGURE 10-17: MCLR/VPP/RG5 PIN BLOCK DIAGRAM

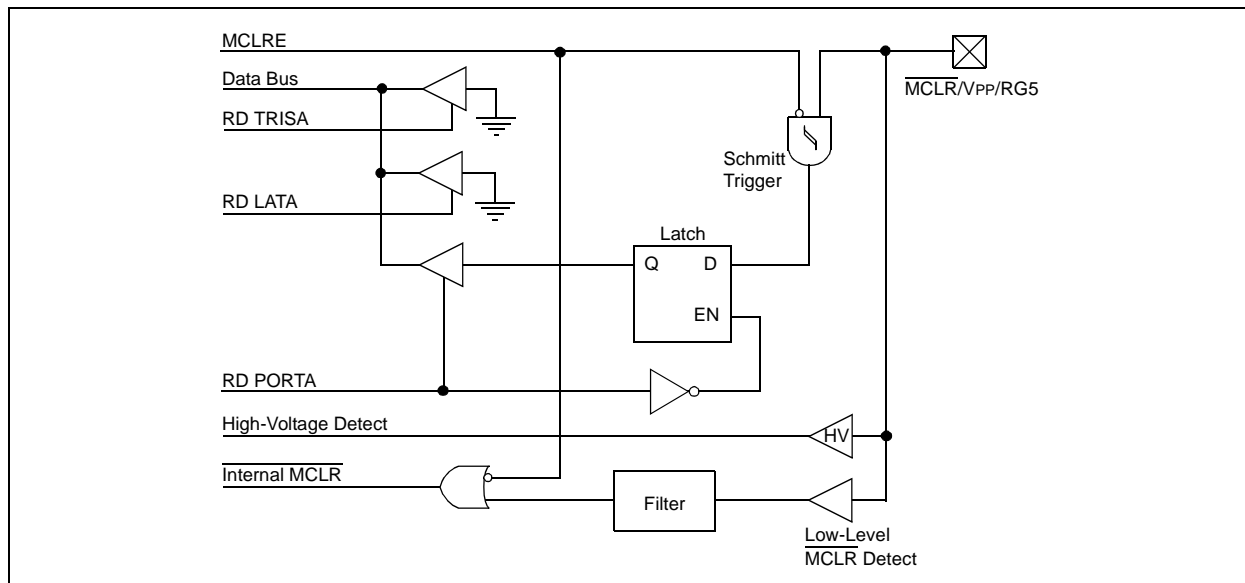

TABLE 10-13: PORTG FUNCTIONS

Name	Bit#	Buffer Type	Function
RG0/ECCP3/P3A	bit 0	ST	Input/output port pin, Enhanced Capture 3 input/Compare 3 output/PWM 3 output or Enhanced PWM 3 output P3A.
RG1/TX2/CK2	bit 1	ST	Input/output port pin, addressable USART2 asynchronous transmit or addressable USART2 synchronous clock.
RG2/RX2/DT2	bit 2	ST	Input/output port pin, addressable USART2 asynchronous receive or addressable USART2 synchronous data.
RG3/CCP4/P3D	bit 3	ST	Input/output port pin, Capture 4 input/Compare 4 output/PWM 4 output or Enhanced PWM 3 output P3D.
RG4/CCP5/P1D	bit 4	ST	Input/output port pin, Capture 5 input/Compare 5 output/PWM 5 output or Enhanced PWM 1 output P1D.
MCLR/VPP/RG5	bit 5	ST	Master Clear input or programming voltage input (if MCLR is enabled). Input only port pin or programming voltage input (if MCLR is disabled).

Legend: ST = Schmitt Trigger input

TABLE 10-14: SUMMARY OF REGISTERS ASSOCIATED WITH PORTG

Name	Bit 7	Bit 6	Bit 5	Bit 4	Bit 3	Bit 2	Bit 1	Bit 0	Value on POR, BOR	Value on all other Resets
PORTG	—	—	RG5 ⁽¹⁾	Read PORTG pins/Write PORTG Data Latch					--xx xxxx	--uu uuuu
LATG	—	—	—	LATG Data Output Register					---x xxxx	---u uuuu
TRISG	—	—	—	Data Direction Control Register for PORTG					---1 1111	---1 1111

Legend: x = unknown, u = unchanged, — = unimplemented, read as '0'

Note 1: RG5 is available as an input only when MCLR is disabled.

PIC18F6525/6621/8525/8621

10.8 PORTH, LATH and TRISH Registers

Note: PORTH is available only on PIC18F8525/8621 devices.

PORTH is an 8-bit wide, bidirectional I/O port. The corresponding data direction register is TRISH. Setting a TRISH bit (= 1) will make the corresponding PORTH pin an input (i.e., put the corresponding output driver in a high-impedance mode). Clearing a TRISH bit (= 0) will make the corresponding PORTH pin an output (i.e., put the contents of the output latch on the selected pin).

Read-modify-write operations on the LATH register, read and write the latched output value for PORTH.

Pins RH7:RH4 are multiplexed with analog inputs AN15:AN12. Pins RH3:RH0 are multiplexed with the system bus as the external memory interface; they are the high-order address bits A19:A16. By default, pins RH7:RH4 are enabled as A/D inputs and pins RH3:RH0 are enabled as the system address bus. Register ADCON1 configures RH7:RH4 as I/O or A/D inputs. Register MEMCON configures RH3:RH0 as I/O or system bus pins.

- Note 1:** On Power-on Reset, PORTH pins RH7:RH4 default to A/D inputs and read as '0'.
- 2:** On Power-on Reset, PORTH pins RH3:RH0 default to system bus signals.

EXAMPLE 10-8: INITIALIZING PORTH

```

CLRF   PORTH   ; Initialize PORTH by
               ; clearing output
               ; data latches
CLRF   LATH    ; Alternate method
               ; to clear output
               ; data latches
MOVLW  0Fh    ;
MOVWF  ADCON1  ;
MOVLW  0CFh   ; Value used to
               ; initialize data
               ; direction
MOVWF  TRISH   ; Set RH3:RH0 as inputs
               ; RH5:RH4 as outputs
               ; RH7:RH6 as inputs
    
```

FIGURE 10-18: RH3:RH0 PINS BLOCK DIAGRAM IN I/O MODE

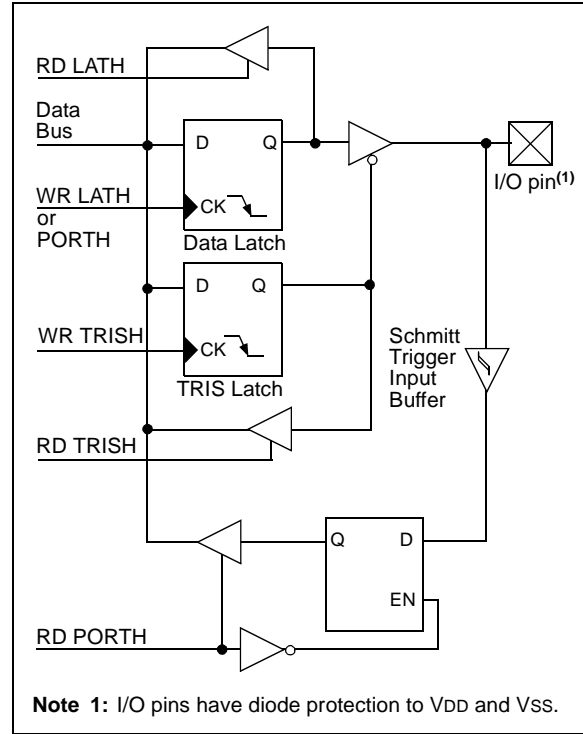
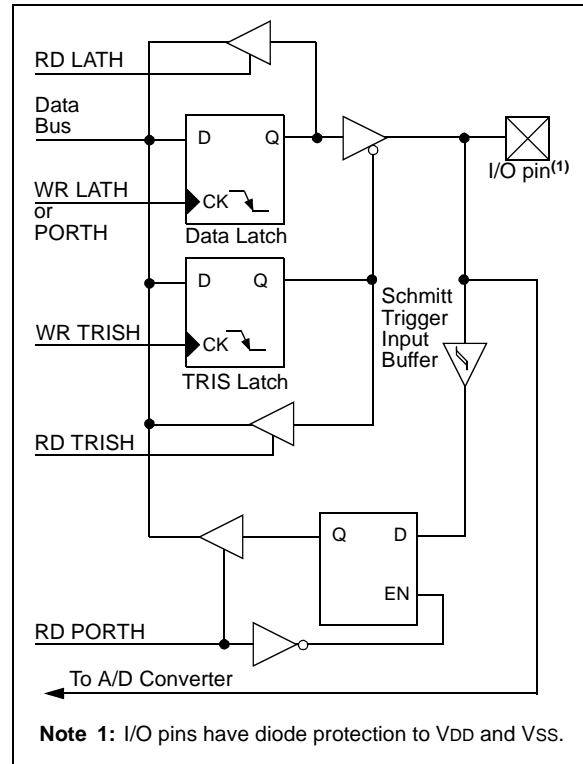
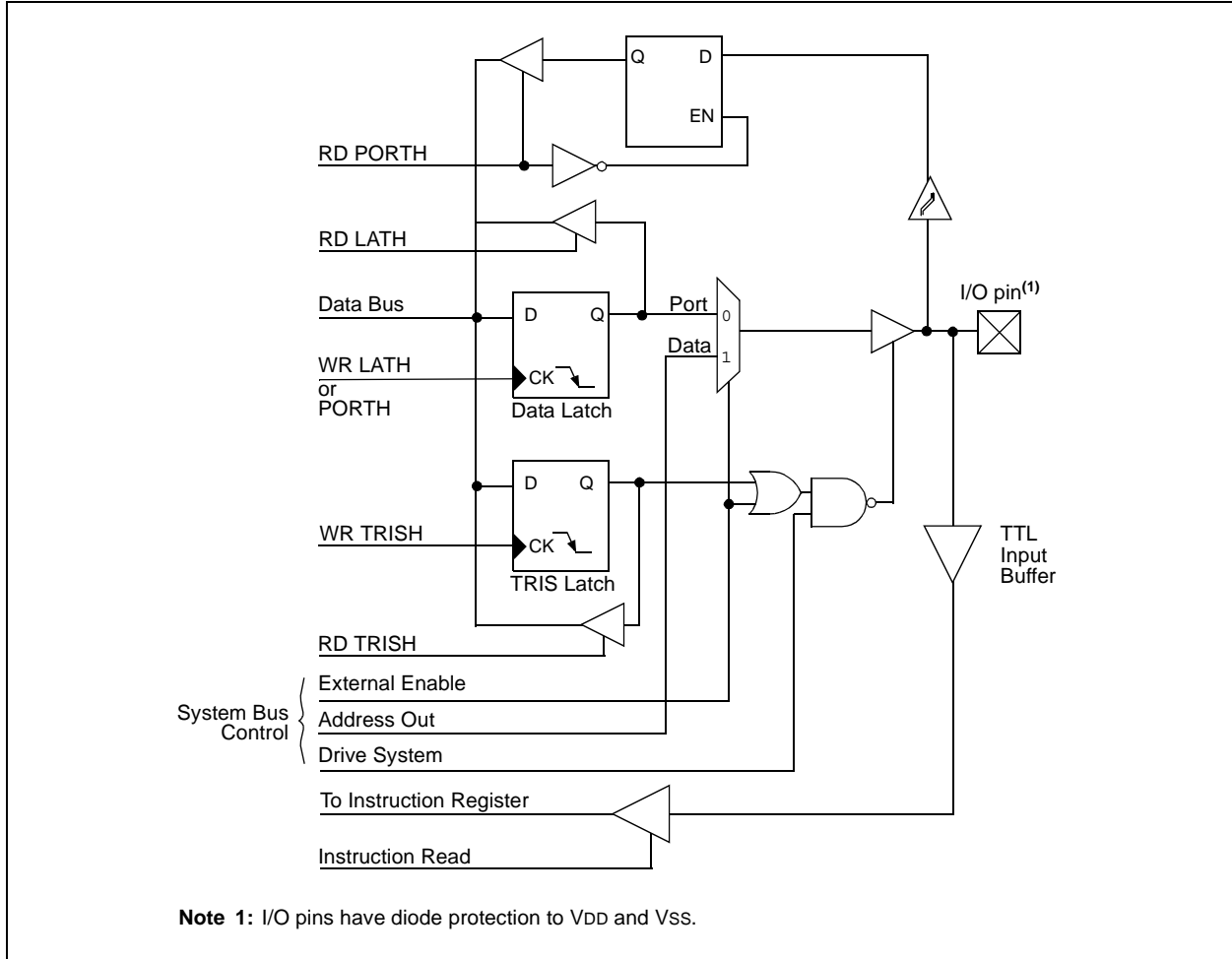

FIGURE 10-19: RH7:RH4 PINS BLOCK DIAGRAM IN I/O MODE



PIC18F6525/6621/8525/8621

FIGURE 10-20: RH3:RH0 PINS BLOCK DIAGRAM IN SYSTEM BUS MODE



PIC18F6525/6621/8525/8621

TABLE 10-15: PORTH FUNCTIONS

Name	Bit#	Buffer Type	Function
RH0/A16	bit 0	ST/TTL ⁽¹⁾	Input/output port pin or address bit 16 for external memory interface.
RH1/A17	bit 1	ST/TTL ⁽¹⁾	Input/output port pin or address bit 17 for external memory interface.
RH2/A18	bit 2	ST/TTL ⁽¹⁾	Input/output port pin or address bit 18 for external memory interface.
RH3/A19	bit 3	ST/TTL ⁽¹⁾	Input/output port pin or address bit 19 for external memory interface.
RH4/AN12/P3C ⁽²⁾	bit 4	ST	Input/output port pin, analog input channel 12 or Enhanced PWM output P3C.
RH5/AN13/P3B ⁽²⁾	bit 5	ST	Input/output port pin, analog input channel 13 or Enhanced PWM output P3B.
RH6/AN14/P1C ⁽²⁾	bit 6	ST	Input/output port pin, analog input channel 14 or Enhanced PWM output P1C.
RH7/AN15/P1B ⁽²⁾	bit 7	ST	Input/output port pin, analog input channel 15 or Enhanced PWM3 output P1B.

Legend: ST = Schmitt Trigger input, TTL = TTL input

Note 1: Input buffers are Schmitt Triggers when in I/O mode and TTL buffers when in System Bus or Parallel Slave Port mode.

2: Valid only for PIC18F8525/8621 devices when ECCPMX is not set. The alternate assignments for P1B/P1C/P3B/P3C in all PIC18F6525/6621 devices and in PIC18F8525/8621 devices when ECCPMX is set are RE6, RE5, RE4 and RE3, respectively.

TABLE 10-16: SUMMARY OF REGISTERS ASSOCIATED WITH PORTH

Name	Bit 7	Bit 6	Bit 5	Bit 4	Bit 3	Bit 2	Bit 1	Bit 0	Value on: POR, BOR	Value on all other Resets
TRISH	PORTH Data Direction Control Register								1111 1111	1111 1111
PORTH	Read PORTH pin/Write PORTH Data Latch								0000 xxxx	0000 uuuu
LATH	Read PORTH Data Latch/Write PORTH Data Latch								xxxx xxxx	uuuu uuuu
ADCON1	—	—	VCFG1	VCFG0	PCFG3	PCFG2	PCFG1	PCFG0	--00 0000	--00 0000
MEMCON ⁽¹⁾	EBDIS	—	WAIT1	WAIT0	—	—	WM1	WM0	0-00 --00	0-00 --00

Legend: x = unknown, u = unchanged, — = unimplemented, read as '0'. Shaded cells are not used by PORTH.

Note 1: This register is unused on PIC18F6525/6621 devices and reads as '0'.

PIC18F6525/6621/8525/8621

10.9 PORTJ, TRISJ and LATJ Registers

Note: PORTJ is available only on PIC18F8525/8621 devices.

PORTJ is an 8-bit wide, bidirectional port. The corresponding data direction register is TRISJ. Setting a TRISJ bit (= 1) will make the corresponding PORTJ pin an input (i.e., put the corresponding output driver in a high-impedance mode). Clearing a TRISJ bit (= 0) will make the corresponding PORTJ pin an output (i.e., put the contents of the output latch on the selected pin).

The Data Latch register (LATJ) is also memory mapped. Read-modify-write operations on the LATJ register, read and write the latched output value for PORTJ.

PORTJ is multiplexed with the system bus as the external memory interface; I/O port functions are only available when the system bus is disabled. When operating as the external memory interface, PORTJ provides the control signal to external memory devices. The RJ5 pin is not multiplexed with any system bus functions.

When enabling peripheral functions, care should be taken in defining TRIS bits for each PORTJ pin. Some peripherals override the TRIS bit to make a pin an output, while other peripherals override the TRIS bit to make a pin an input. The user should refer to the corresponding peripheral section for the correct TRIS bit settings.

Note: On a Power-on Reset, these pins are configured as digital inputs.

The pin override value is not loaded into the TRIS register. This allows read-modify-write of the TRIS register without concern due to peripheral overrides.

EXAMPLE 10-9: INITIALIZING PORTJ

```
CLRF   PORTJ   ; Initialize PORTG by
              ; clearing output
              ; data latches
CLRF   LATJ    ; Alternate method
              ; to clear output
              ; data latches
MOVLW  0xCF   ; Value used to
              ; initialize data
              ; direction
MOVWF  TRISJ  ; Set RJ3:RJ0 as inputs
              ; RJ5:RJ4 as output
              ; RJ7:RJ6 as inputs
```

FIGURE 10-21: PORTJ BLOCK DIAGRAM IN I/O MODE

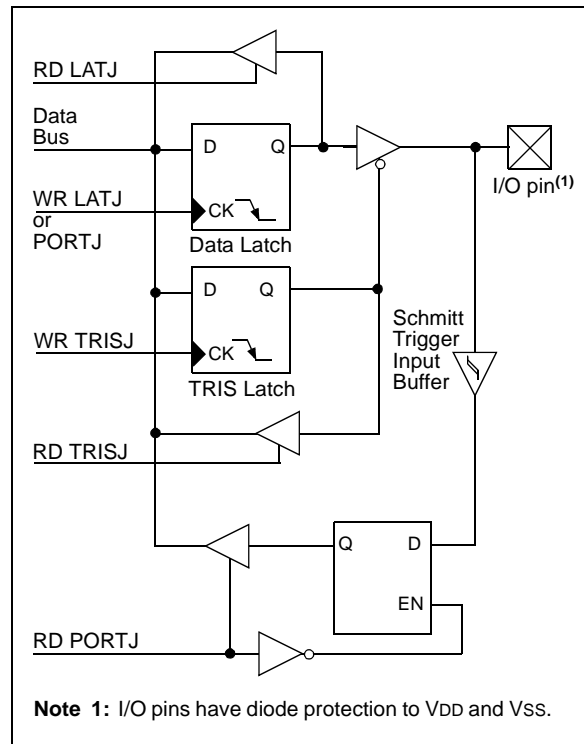

PIC18F6525/6621/8525/8621

FIGURE 10-22: RJ4:RJ0 PINS BLOCK DIAGRAM IN SYSTEM BUS MODE

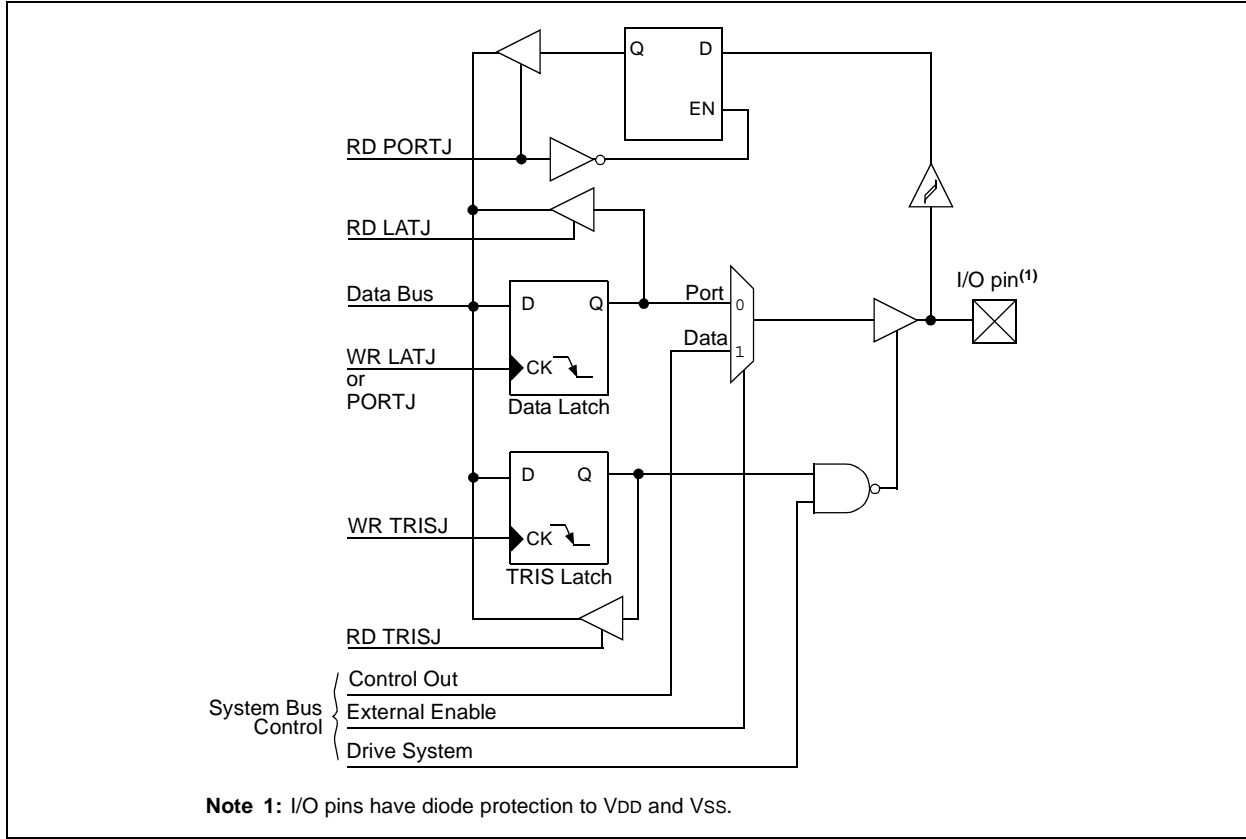
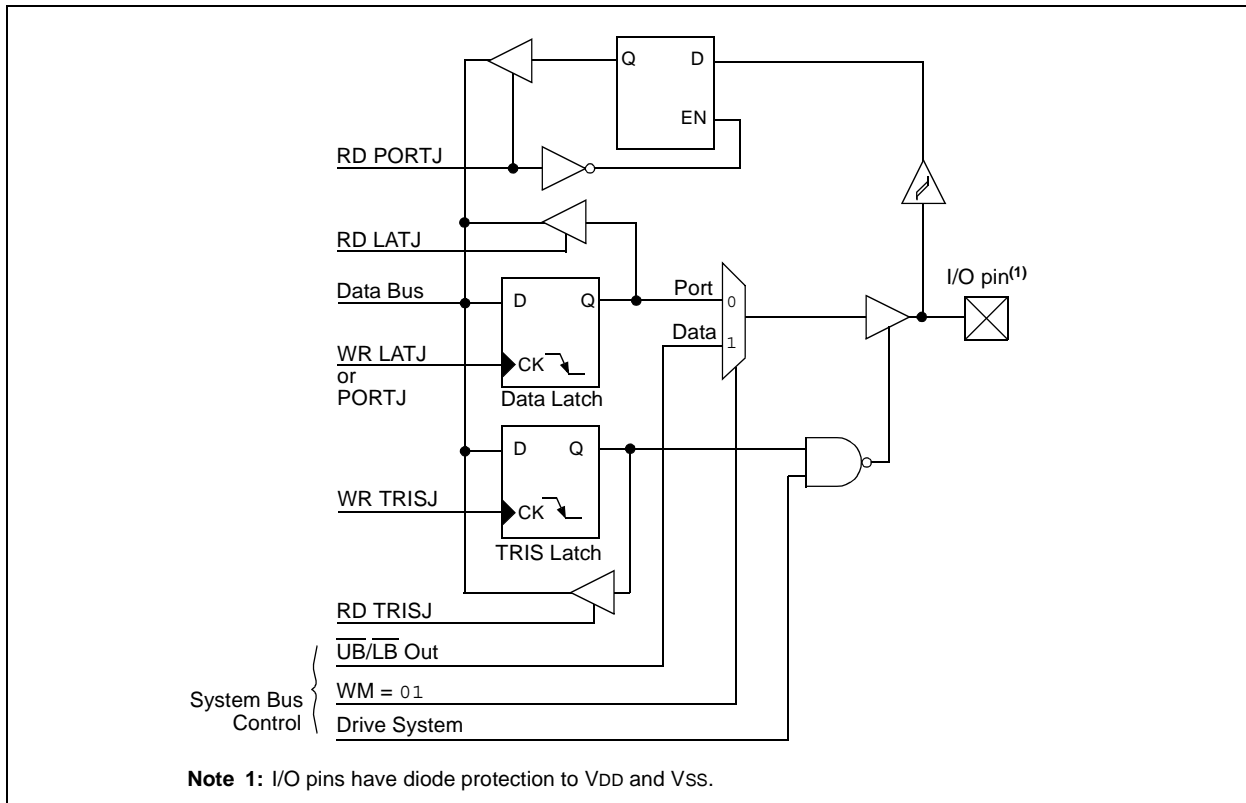

FIGURE 10-23: RJ7:RJ6 PINS BLOCK DIAGRAM IN SYSTEM BUS MODE



PIC18F6525/6621/8525/8621

TABLE 10-17: PORTJ FUNCTIONS

Name	Bit#	Buffer Type	Function
RJ0/ALE	bit 0	ST	Input/output port pin or address latch enable control for external memory interface.
RJ1/ \overline{OE}	bit 1	ST	Input/output port pin or output enable control for external memory interface.
RJ2/ \overline{WRL}	bit 2	ST	Input/output port pin or write low byte control for external memory interface.
RJ3/ \overline{WRH}	bit 3	ST	Input/output port pin or write high byte control for external memory interface.
RJ4/BA0	bit 4	ST	Input/output port pin or byte address 0 control for external memory interface.
RJ5/ \overline{CE}	bit 5	ST	Input/output port pin or chip enable control for external memory interface.
RJ6/ \overline{LB}	bit 6	ST	Input/output port pin or lower byte select control for external memory interface.
RJ7/ \overline{UB}	bit 7	ST	Input/output port pin or upper byte select control for external memory interface.

Legend: ST = Schmitt Trigger input

TABLE 10-18: SUMMARY OF REGISTERS ASSOCIATED WITH PORTJ

Name	Bit 7	Bit 6	Bit 5	Bit 4	Bit 3	Bit 2	Bit 1	Bit 0	Value on POR, BOR	Value on all other Resets
PORTJ	Read PORTJ pin/Write PORTJ Data Latch								xxxx xxxx	uuuu uuuu
LATJ	LATJ Data Output Register								xxxx xxxx	uuuu uuuu
TRISJ	Data Direction Control Register for PORTJ								1111 1111	1111 1111

Legend: x = unknown, u = unchanged

PIC18F6525/6621/8525/8621

10.10 Parallel Slave Port

PORTD also operates as an 8-bit wide Parallel Slave Port, or microprocessor port, when control bit PSPMODE (PSPCON<4>) is set. It is asynchronously readable and writable by the external world through \overline{RD} control input pin, RE0/ \overline{RD} and \overline{WR} control input pin, RE1/ \overline{WR} .

Note: For PIC18F8525/8621 devices, the Parallel Slave Port is available only in Microcontroller mode.

The PSP can directly interface to an 8-bit microprocessor data bus. The external microprocessor can read or write the PORTD latch as an 8-bit latch. Setting bit PSPMODE enables port pin RE0/ \overline{RD} to be the \overline{RD} input, RE1/ \overline{WR} to be the \overline{WR} input and RE2/ \overline{CS} to be the \overline{CS} (chip select) input. For this functionality, the corresponding data direction bits of the TRISE register (TRISE<2:0>) must be configured as inputs (set). The A/D port configuration bits, PCFG2:PCFG0 (ADCON1<2:0>), must be set, which will configure pins RE2:RE0 as digital I/O.

A write to the PSP occurs when both the \overline{CS} and \overline{WR} lines are first detected low. A read from the PSP occurs when both the \overline{CS} and \overline{RD} lines are first detected low.

The PORTE I/O pins become control inputs for the microprocessor port when bit PSPMODE (PSPCON<4>) is set. In this mode, the user must make sure that the TRISE<2:0> bits are set (pins are configured as digital inputs) and the ADCON1 is configured for digital I/O. In this mode, the input buffers are TTL.

FIGURE 10-24: PORTD AND PORTE BLOCK DIAGRAM (PARALLEL SLAVE PORT)

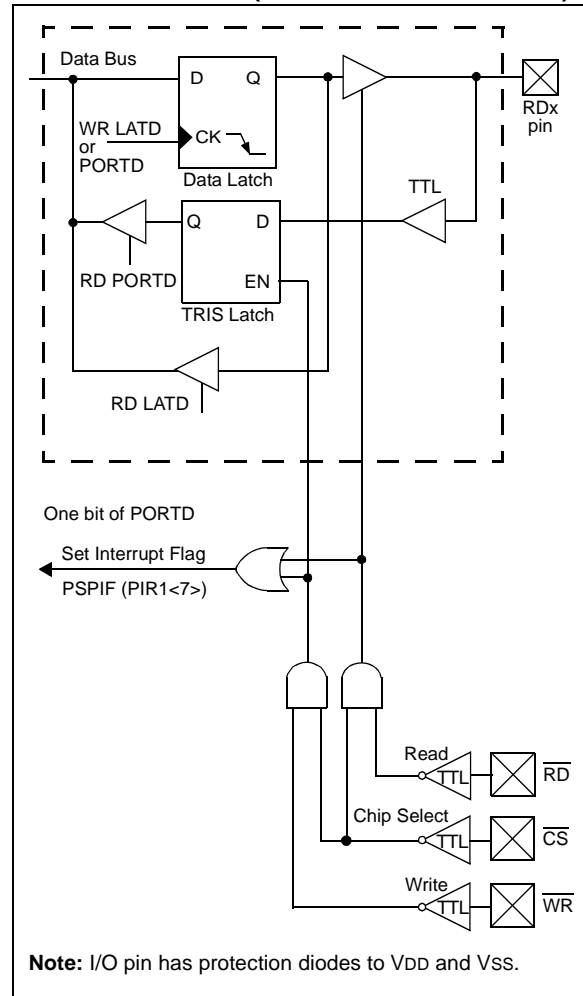

PIC18F6525/6621/8525/8621

REGISTER 10-1: PSPCON: PARALLEL SLAVE PORT CONTROL REGISTER⁽¹⁾

R-0	R-0	R/W-0	R/W-0	U-0	U-0	U-0	U-0
IBF	OBF	IBOV	PSPMODE	—	—	—	—
bit 7				bit 0			

bit 7 **IBF:** Input Buffer Full Status bit

1 = A word has been received and is waiting to be read by the CPU

0 = No word has been received

bit 6 **OBF:** Output Buffer Full Status bit

1 = The output buffer still holds a previously written word

0 = The output buffer has been read

bit 5 **IBOV:** Input Buffer Overflow Detect bit

1 = A write occurred when a previously input word has not been read
(must be cleared in software)

0 = No overflow occurred

bit 4 **PSPMODE:** Parallel Slave Port Mode Select bit

1 = Parallel Slave Port mode

0 = General Purpose I/O mode

bit 3-0 **Unimplemented:** Read as '0'

Note 1: Enabled only in Microcontroller mode for PIC18F8525/8621 devices.

Legend:

R = Readable bit

W = Writable bit

U = Unimplemented bit, read as '0'

-n = Value at POR

'1' = Bit is set

'0' = Bit is cleared

x = Bit is unknown

FIGURE 10-25: PARALLEL SLAVE PORT WRITE WAVEFORMS

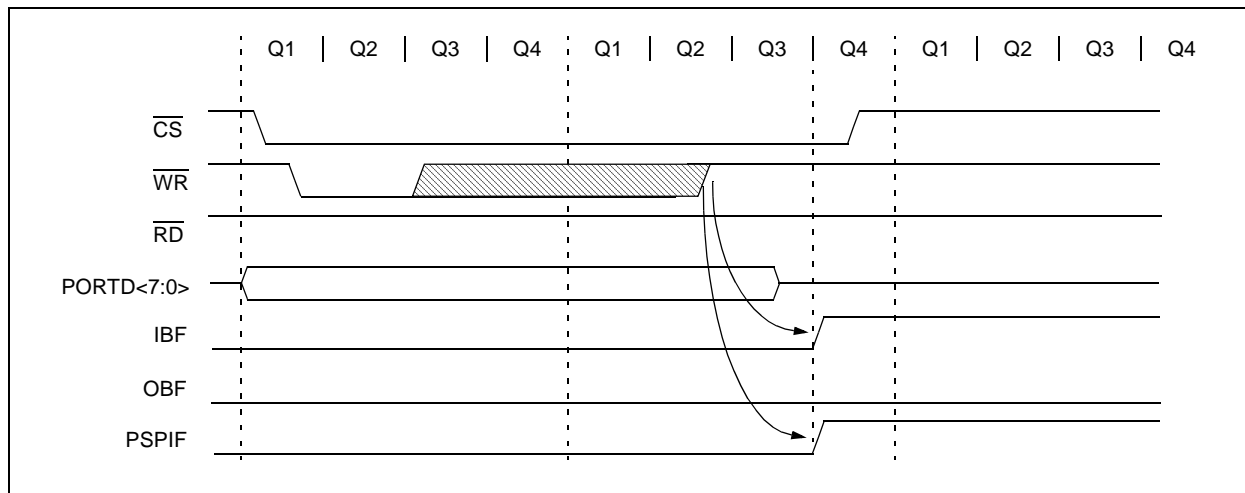

PIC18F6525/6621/8525/8621

FIGURE 10-26: PARALLEL SLAVE PORT READ WAVEFORMS

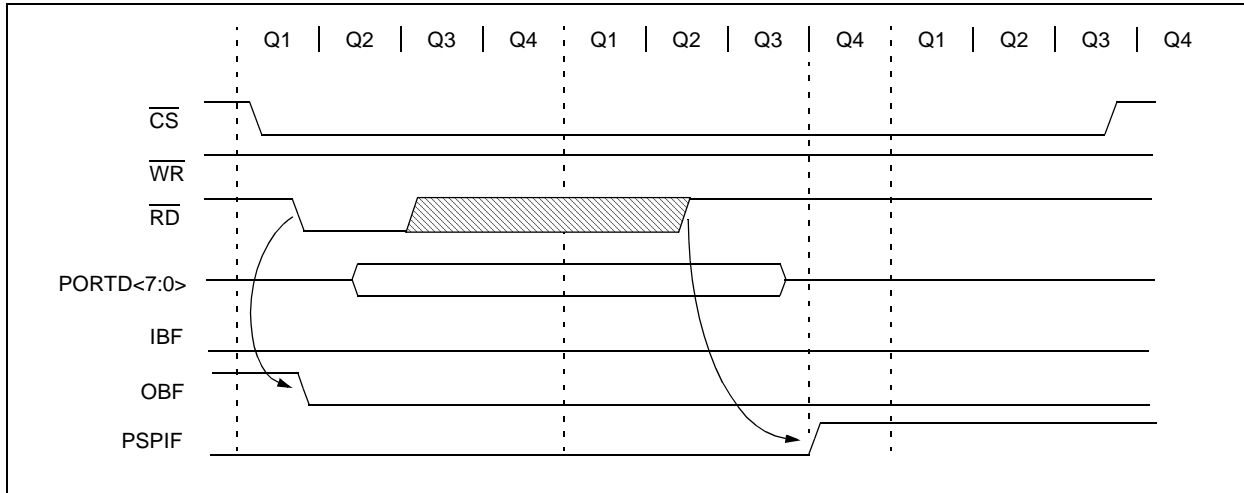

TABLE 10-19: REGISTERS ASSOCIATED WITH PARALLEL SLAVE PORT

Name	Bit 7	Bit 6	Bit 5	Bit 4	Bit 3	Bit 2	Bit 1	Bit 0	Value on POR, BOR	Value on all other Resets
PORTD	Port Data Latch when written; Port pins when read								xxxx xxxx	uuuu uuuu
LATD	LATD Data Output bits								xxxx xxxx	uuuu uuuu
TRISD	PORTD Data Direction bits								1111 1111	1111 1111
PORTE	Read PORTE pin/Write PORTE Data Latch								xxxx xxxx	uuuu uuuu
LATE	LATE Data Output bits								xxxx xxxx	uuuu uuuu
TRISE	PORTE Data Direction bits								1111 1111	1111 1111
PSPCON ⁽¹⁾	IBF	OBF	IBOV	PSPMODE	—	—	—	—	0000 ----	0000 ----
INTCON	GIE/GIEH	PEIE/GIEL	TMR0IE	INT0IE	RBIE	TMR0IF	INT0IF	RBIF	0000 000x	0000 000u
PIR1	PSPIF ⁽¹⁾	ADIF	RC1IF	TX1IF	SSPIF	CCP1IF	TMR2IF	TMR1IF	0000 0000	0000 0000
PIE1	PSPIE ⁽¹⁾	ADIE	RC1IE	TX1IE	SSPIE	CCP1IE	TMR2IE	TMR1IE	0000 0000	0000 0000
IPR1	PSPIP ⁽¹⁾	ADIP	RC1IP	TX1IP	SSPIP	CCP1IP	TMR2IP	TMR1IP	1111 1111	1111 1111

Legend: x = unknown, u = unchanged, — = unimplemented, read as '0'. Shaded cells are not used by the Parallel Slave Port.

Note 1: Enabled only in Microcontroller mode for PIC18F8525/8621 devices.

PIC18F6525/6621/8525/8621

11.0 TIMER0 MODULE

The Timer0 module has the following features:

- Software selectable as an 8-bit or 16-bit timer/counter
- Readable and writable
- Dedicated 8-bit software programmable prescaler
- Clock source selectable to be external or internal
- Interrupt-on-overflow from FFh to 00h in 8-bit mode and FFFFh to 0000h in 16-bit mode
- Edge select for external clock

Figure 11-1 shows a simplified block diagram of the Timer0 module in 8-bit mode and Figure 11-2 shows a simplified block diagram of the Timer0 module in 16-bit mode.

The T0CON register (Register 11-1) is a readable and writable register that controls all the aspects of Timer0, including the prescale selection.

REGISTER 11-1: T0CON: TIMER0 CONTROL REGISTER

R/W-1	R/W-1	R/W-1	R/W-1	R/W-1	R/W-1	R/W-1	R/W-1
TMROON	T08BIT	T0CS	T0SE	PSA	T0PS2	T0PS1	T0PS0
bit 7						bit 0	

- bit 7 **TMROON:** Timer0 On/Off Control bit
 1 = Enables Timer0
 0 = Stops Timer0
- bit 6 **T08BIT:** Timer0 8-bit/16-bit Control bit
 1 = Timer0 is configured as an 8-bit timer/counter
 0 = Timer0 is configured as a 16-bit timer/counter
- bit 5 **T0CS:** Timer0 Clock Source Select bit
 1 = Transition on T0CKI pin
 0 = Internal instruction cycle clock (CLKO)
- bit 4 **T0SE:** Timer0 Source Edge Select bit
 1 = Increment on high-to-low transition on T0CKI pin
 0 = Increment on low-to-high transition on T0CKI pin
- bit 3 **PSA:** Timer0 Prescaler Assignment bit
 1 = Timer0 prescaler is not assigned. Timer0 clock input bypasses prescaler.
 0 = Timer0 prescaler is assigned. Timer0 clock input comes from prescaler output.
- bit 2-0 **T0PS2:T0PS0:** Timer0 Prescaler Select bits
 111 = 1:256 Prescale value
 110 = 1:128 Prescale value
 101 = 1:64 Prescale value
 100 = 1:32 Prescale value
 011 = 1:16 Prescale value
 010 = 1:8 Prescale value
 001 = 1:4 Prescale value
 000 = 1:2 Prescale value

Legend:

R = Readable bit	W = Writable bit	U = Unimplemented bit, read as '0'
-n = Value at POR	'1' = Bit is set	'0' = Bit is cleared x = Bit is unknown

PIC18F6525/6621/8525/8621

FIGURE 11-1: TIMER0 BLOCK DIAGRAM IN 8-BIT MODE

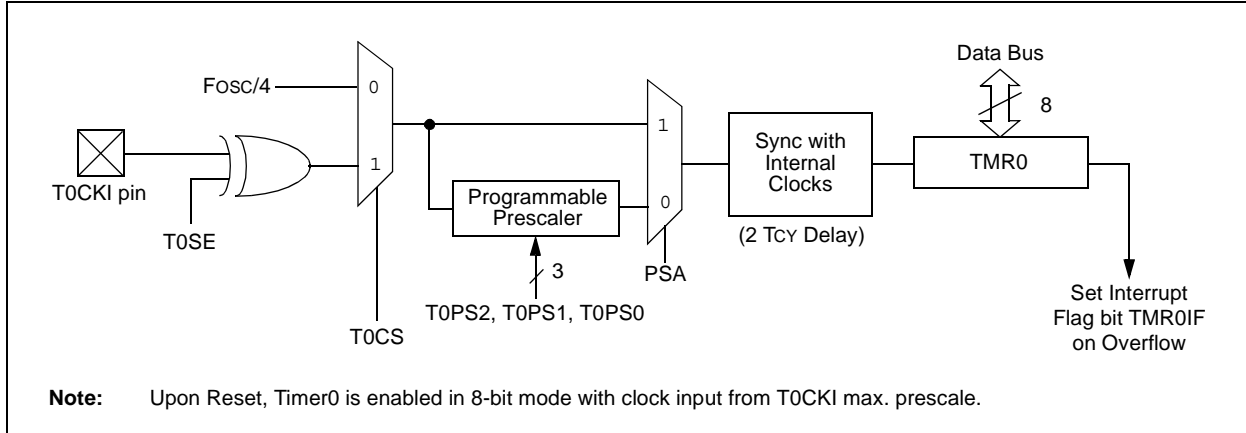
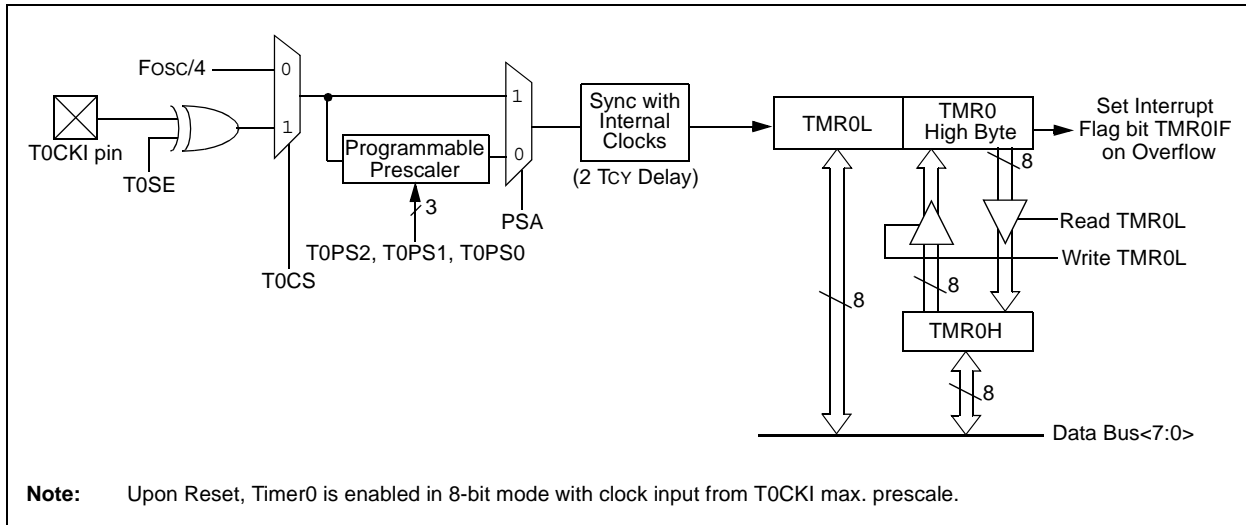

FIGURE 11-2: TIMER0 BLOCK DIAGRAM IN 16-BIT MODE



PIC18F6525/6621/8525/8621

11.1 Timer0 Operation

Timer0 can operate as a timer or as a counter.

Timer mode is selected by clearing the T0CS bit. In Timer mode, the Timer0 module will increment every instruction cycle (without prescaler). If the TMR0 register is written, the increment is inhibited for the following two instruction cycles. The user can work around this by writing an adjusted value to the TMR0 register.

Counter mode is selected by setting the T0CS bit. In Counter mode, Timer0 will increment, either on every rising or falling edge of pin RA4/T0CKI. The incrementing edge is determined by the Timer0 Source Edge Select bit (T0SE). Clearing the T0SE bit selects the rising edge. Restrictions on the external clock input are discussed below.

When an external clock input is used for Timer0, it must meet certain requirements. The requirements ensure the external clock can be synchronized with the internal phase clock (Tosc). Also, there is a delay in the actual incrementing of Timer0 after synchronization.

11.2 Prescaler

An 8-bit counter is available as a prescaler for the Timer0 module. The prescaler is not readable or writable.

The PSA and T0PS2:T0PS0 bits determine the prescaler assignment and prescale ratio.

Clearing bit PSA will assign the prescaler to the Timer0 module. When the prescaler is assigned to the Timer0 module, prescale values of 1:2, 1:4, ..., 1:256 are selectable.

When assigned to the Timer0 module, all instructions writing to the TMR0 register (e.g., CLRF TMR0, MOVWF TMR0, BSF TMR0, x and so on) will clear the prescaler count.

Note: Writing to TMR0 when the prescaler is assigned to Timer0 will clear the prescaler count, but will not change the prescaler assignment.

11.2.1 SWITCHING PRESCALER ASSIGNMENT

The prescaler assignment is fully under software control, (i.e., it can be changed “on-the-fly” during program execution).

11.3 Timer0 Interrupt

The TMR0 interrupt is generated when the TMR0 register overflows from FFh to 00h in 8-bit mode, or FFFFh to 0000h in 16-bit mode. This overflow sets the TMR0IF bit. The interrupt can be masked by clearing the TMR0IE bit. The TMR0IE bit must be cleared in software by the Timer0 module Interrupt Service Routine before re-enabling this interrupt. The TMR0 interrupt cannot awaken the processor from Sleep since the timer is shut off during Sleep.

11.4 16-Bit Mode Timer Reads and Writes

TMR0H is not the high byte of the timer/counter in 16-bit mode, but is actually a buffered version of the high byte of Timer0 (refer to Figure 11-2). The high byte of the Timer0 counter/timer is not directly readable nor writable. TMR0H is updated with the contents of the high byte of Timer0 during a read of TMR0L. This provides the ability to read all 16 bits of Timer0 without having to verify that the read of the high and low byte were valid, due to a rollover between successive reads of the high and low byte.

A write to the high byte of Timer0 must also take place through the TMR0H Buffer register. Timer0 high byte is updated with the contents of TMR0H when a write occurs to TMR0L. This allows all 16 bits of Timer0 to be updated at once.

TABLE 11-1: REGISTERS ASSOCIATED WITH TIMER0

Name	Bit 7	Bit 6	Bit 5	Bit 4	Bit 3	Bit 2	Bit 1	Bit 0	Value on POR, BOR	Value on all other Resets
TMR0L	Timer0 Low Byte Register								xxxx xxxx	uuuu uuuu
TMR0H	Timer0 High Byte Register								0000 0000	uuuu uuuu
INTCON	GIE/GIEH	PEIE/GIEL	TMR0IE	INT0IE	RBIE	TMR0IF	INT0IF	RBIF	0000 000x	0000 000u
TOCON	TMR0ON	T08BIT	T0CS	T0SE	PSA	T0PS2	T0PS1	T0PS0	1111 1111	1111 1111
TRISA	—	TRISA6 ⁽¹⁾	PORTA Data Direction Register						-111 1111	-111 1111

Legend: x = unknown, u = unchanged, — = unimplemented locations, read as ‘0’. Shaded cells are not used by Timer0.

Note 1: RA6 and associated bits are configured as port pins in RCIO and ECIO Oscillator modes only and read ‘0’ in all other oscillator modes.

PIC18F6525/6621/8525/8621

NOTES:

PIC18F6525/6621/8525/8621

12.0 TIMER1 MODULE

The Timer1 module timer/counter has the following features:

- 16-bit timer/counter (two 8-bit registers: TMR1H and TMR1L)
- Readable and writable (both registers)
- Internal or external clock select
- Interrupt-on-overflow from FFFFh to 0000h
- Reset from ECCP module special event trigger

Figure 12-1 is a simplified block diagram of the Timer1 module.

Register 12-1 details the Timer1 Control register. This register controls the operating mode of the Timer1 module and contains the Timer1 oscillator enable bit (T1OSCEN). Timer1 can be enabled or disabled by setting or clearing control bit, TMR1ON (T1CON<0>).

Timer1 can also be used to provide Real-Time Clock (RTC) functionality to applications with only a minimal addition of external components and code overhead.

REGISTER 12-1: T1CON: TIMER1 CONTROL REGISTER

R/W-0	U-0	R/W-0	R/W-0	R/W-0	R/W-0	R/W-0	R/W-0
RD16	—	T1CKPS1	T1CKPS0	T1OSCEN	T1SYNC	TMR1CS	TMR1ON
bit 7							bit 0

- bit 7 **RD16:** 16-bit Read/Write Mode Enable bit
 1 = Enables register read/write of Timer1 in one 16-bit operation
 0 = Enables register read/write of Timer1 in two 8-bit operations
- bit 6 **Unimplemented:** Read as '0'
- bit 5-4 **T1CKPS1:T1CKPS0:** Timer1 Input Clock Prescale Select bits
 11 = 1:8 Prescale value
 10 = 1:4 Prescale value
 01 = 1:2 Prescale value
 00 = 1:1 Prescale value
- bit 3 **T1OSCEN:** Timer1 Oscillator Enable bit
 1 = Timer1 oscillator is enabled
 0 = Timer1 oscillator is shut off
 The oscillator inverter and feedback resistor are turned off to eliminate power drain.
- bit 2 **T1SYNC:** Timer1 External Clock Input Synchronization Select bit
When TMR1CS = 1:
 1 = Do not synchronize external clock input
 0 = Synchronize external clock input
When TMR1CS = 0:
 This bit is ignored. Timer1 uses the internal clock when TMR1CS = 0.
- bit 1 **TMR1CS:** Timer1 Clock Source Select bit
 1 = External clock from pin RC0/T1OSO/T13CKI (on the rising edge)
 0 = Internal clock (FOSC/4)
- bit 0 **TMR1ON:** Timer1 On bit
 1 = Enables Timer1
 0 = Stops Timer1

Legend:			
R = Readable bit	W = Writable bit	U = Unimplemented bit, read as '0'	
-n = Value at POR	'1' = Bit is set	'0' = Bit is cleared	x = Bit is unknown

PIC18F6525/6621/8525/8621

12.1 Timer1 Operation

Timer1 can operate in one of these modes:

- As a timer
- As a synchronous counter
- As an asynchronous counter

The operating mode is determined by the clock select bit, TMR1CS (T1CON<1>).

When TMR1CS = 0, Timer1 increments every instruction cycle. When TMR1CS = 1, Timer1 increments on every rising edge of the external clock input or the Timer1 oscillator, if enabled.

When the Timer1 oscillator is enabled (T1OSCEN is set), the RC1/T1OSI and RC0/T1OSO/T13CKI pins become inputs. That is, the TRISC<1:0> value is ignored and the pins are read as '0'.

Timer1 also has an internal "Reset input". This Reset can be generated by the ECCP1 or ECCP2 special event trigger. This is discussed in detail in **Section 12.4 "Resetting Timer1 Using an ECCP Special Trigger Output"**.

FIGURE 12-1: TIMER1 BLOCK DIAGRAM

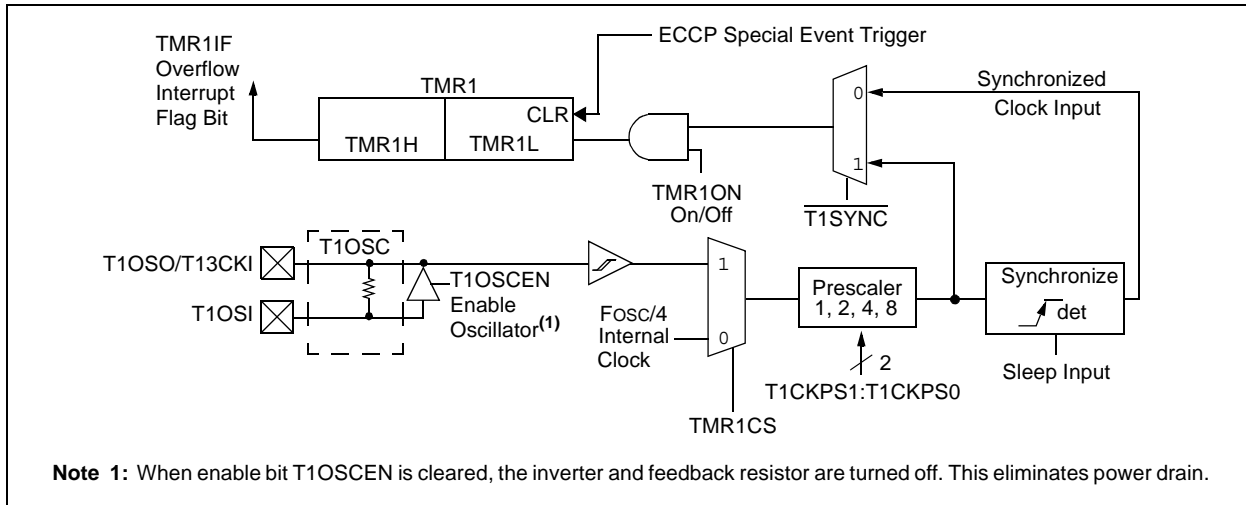
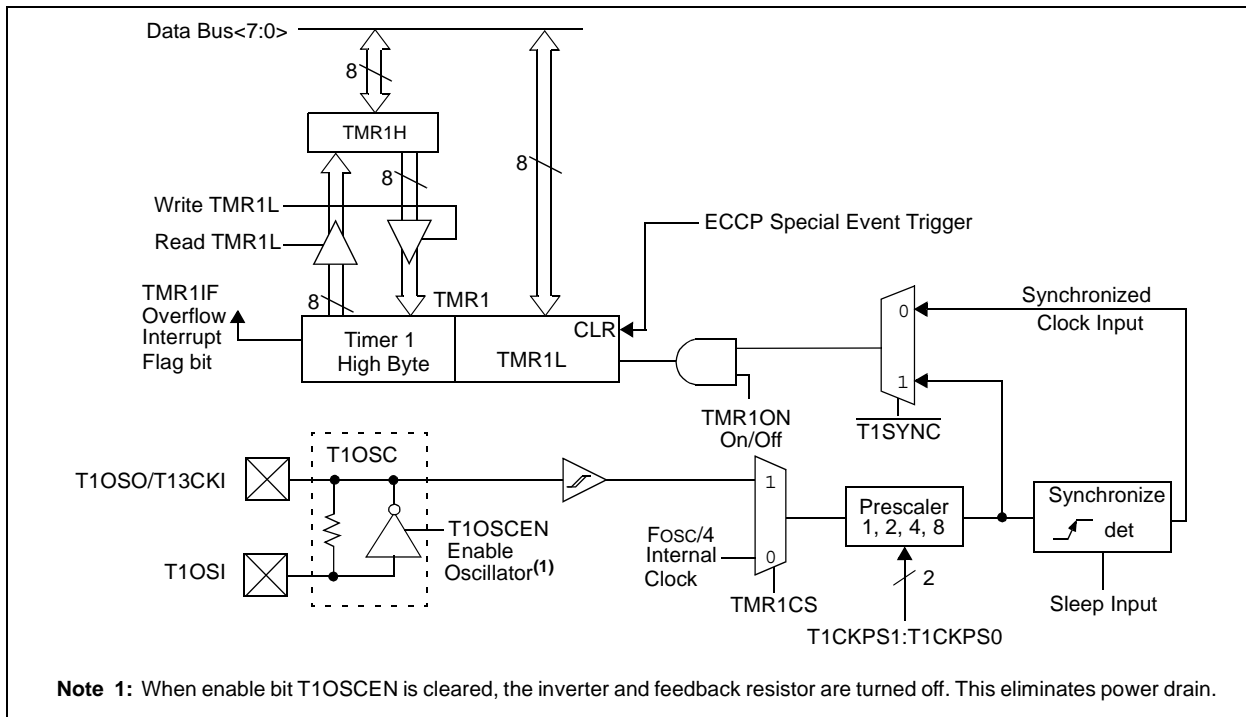

FIGURE 12-2: TIMER1 BLOCK DIAGRAM: 16-BIT READ/WRITE MODE



12.2 Timer1 Oscillator

A crystal oscillator circuit is built-in between pins T1OSI (input) and T1OSO (amplifier output). It is enabled by setting control bit T1OSCEN (T1CON<3>). The oscillator is a low-power oscillator rated up to 200 kHz. It will continue to run during Sleep. It is primarily intended for a 32 kHz crystal. The circuit for a typical LP oscillator is shown in Figure 12-3. Table 12-1 shows the capacitor selection for the Timer1 oscillator.

The user must provide a software time delay to ensure proper start-up of the Timer1 oscillator.

FIGURE 12-3: EXTERNAL COMPONENTS FOR THE TIMER1 LP OSCILLATOR

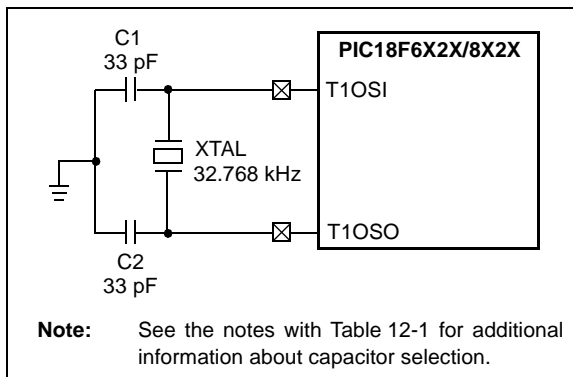

TABLE 12-1: CAPACITOR SELECTION FOR THE ALTERNATE OSCILLATOR⁽²⁻⁴⁾

Osc Type	Freq	C1	C2
LP	32 kHz	15-22 pF ⁽¹⁾	15-22 pF ⁽¹⁾
Crystal Tested			
32.768 kHz			

Note 1: Microchip suggests 33 pF as a starting point in validating the oscillator circuit.

2: Higher capacitance increases the stability of the oscillator but also increases the start-up time.

3: Since each resonator/crystal has its own characteristics, the user should consult the resonator/crystal manufacturer for appropriate values of external components.

4: Capacitor values are for design guidance only.

12.3 Timer1 Interrupt

The TMR1 register pair (TMR1H:TMR1L) increments from 0000h to FFFFh and rolls over to 0000h. The TMR1 interrupt, if enabled, is generated on overflow which is latched in interrupt flag bit, TMR1IF (PIR1<0>). This interrupt can be enabled/disabled by setting/clearing the TMR1 Interrupt Enable bit, TMR1IE (PIE1<0>).

12.4 Resetting Timer1 Using an ECCP Special Trigger Output

If either the ECCP1 or ECCP2 module is configured in Compare mode to generate a “special event trigger” (CCP1M3:CCP1M0 = 1011), this signal will reset Timer1. The trigger for ECCP2 will also start an A/D conversion if the A/D module is enabled.

Note: The special event triggers from the ECCP1 module will not set interrupt flag bit TMR1IF (PIR1<0>).

Timer1 must be configured for either Timer or Synchronized Counter mode to take advantage of this feature. If Timer1 is running in Asynchronous Counter mode, this Reset operation may not work.

In the event that a write to Timer1 coincides with a special event trigger from ECCP1, the write will take precedence.

In this mode of operation, the CCPR1H:CCPR1L register pair effectively becomes the period register for Timer1.

12.5 Timer1 16-Bit Read/Write Mode

Timer1 can be configured for 16-bit reads and writes (see Figure 12-2). When the RD16 control bit (T1CON<7>) is set, the address for TMR1H is mapped to a buffer register for the high byte of Timer1. A read from TMR1L will load the contents of the high byte of Timer1 into the Timer1 High Byte Buffer register. This provides the user with the ability to accurately read all 16 bits of Timer1 without having to determine whether a read of the high byte, followed by a read of the low byte, is valid due to a rollover between reads.

A write to the high byte of Timer1 must also take place through the TMR1H Buffer register. Timer1 high byte is updated with the contents of TMR1H when a write occurs to TMR1L. This allows a user to write all 16 bits to both the high and low bytes of Timer1 at once.

The high byte of Timer1 is not directly readable or writable in this mode. All reads and writes must take place through the Timer1 High Byte Buffer register. Writes to TMR1H do not clear the Timer1 prescaler. The prescaler is only cleared on writes to TMR1L.

PIC18F6525/6621/8525/8621

12.6 Using Timer1 as a Real-Time Clock

Adding an external LP oscillator to Timer1 (such as the one described in **Section 12.2 “Timer1 Oscillator”**) gives users the option to include RTC functionality to their applications. This is accomplished with an inexpensive watch crystal to provide an accurate time base and several lines of application code to calculate the time. When operating in Sleep mode and using a battery or supercapacitor as a power source, it can completely eliminate the need for a separate RTC device and battery backup.

The application code routine, `RTCisr`, shown in Example 12-1, demonstrates a simple method to increment a counter at one-second intervals using an Interrupt Service Routine. Incrementing the TMR1 register pair to overflow, triggers the interrupt and calls

the routine which increments the seconds counter by one; additional counters for minutes and hours are incremented as the previous counter overflow.

Since the register pair is 16 bits wide, counting up to overflow the register directly from a 32.768 kHz clock would take 2 seconds. To force the overflow at the required one-second intervals, it is necessary to preload it. The simplest method is to set the Most Significant bit of TMR1H with a `BSF` instruction. Note that the TMR1L register is never preloaded or altered; doing so may introduce cumulative error over many cycles.

For this method to be accurate, Timer1 must operate in Asynchronous mode and the Timer1 overflow interrupt must be enabled (`PIE1<0> = 1`), as shown in the routine, `RTCinit`. The Timer1 oscillator must also be enabled and running at all times.

EXAMPLE 12-1: IMPLEMENTING A REAL-TIME CLOCK USING A TIMER1 INTERRUPT SERVICE

```
RTCinit
    MOVLW    0x80          ; Preload TMR1 register pair
    MOVWF   TMR1H        ; for 1 second overflow
    CLRF    TMR1L
    MOVLW   b'00001111'   ; Configure for external clock,
    MOVWF   T1CON        ; Asynchronous operation, external oscillator
    CLRF    secs         ; Initialize timekeeping registers
    CLRF    mins
    MOVLW   .12
    MOVWF   hours
    BSF     PIE1, TMR1IE ; Enable Timer1 interrupt
    RETURN

RTCisr
    BSF     TMR1H, 7      ; Preload for 1 sec overflow
    BCF     PIR1, TMR1IF ; Clear interrupt flag
    INCF    secs, F       ; Increment seconds
    MOVLW   .59          ; 60 seconds elapsed?
    CPFSGT secs
    RETURN               ; No, done
    CLRF    secs         ; Clear seconds
    INCF    mins, F      ; Increment minutes
    MOVLW   .59          ; 60 minutes elapsed?
    CPFSGT mins
    RETURN               ; No, done
    CLRF    mins         ; clear minutes
    INCF    hours, F     ; Increment hours
    MOVLW   .23          ; 24 hours elapsed?
    CPFSGT hours
    RETURN               ; No, done
    MOVLW   .01          ; Reset hours to 1
    MOVWF   hours
    RETURN               ; Done
```

PIC18F6525/6621/8525/8621

TABLE 12-2: REGISTERS ASSOCIATED WITH TIMER1 AS A TIMER/COUNTER

Name	Bit 7	Bit 6	Bit 5	Bit 4	Bit 3	Bit 2	Bit 1	Bit 0	Value on POR, BOR	Value on all other Resets
INTCON	GIE/GIEH	PEIE/GIEL	TMR0IE	INT0IE	RBIE	TMR0IF	INT0IF	RBIF	0000 000x	0000 000u
PIR1	PSPIF ⁽¹⁾	ADIF	RC1IF	TX1IF	SSPIF	CCP1IF	TMR2IF	TMR1IF	0000 0000	0000 0000
PIE1	PSPIE ⁽¹⁾	ADIE	RC1IE	TX1IE	SSPIE	CCP1IE	TMR2IE	TMR1IE	0000 0000	0000 0000
IPR1	PSPIP ⁽¹⁾	ADIP	RC1IP	TX1IP	SSPIP	CCP1IP	TMR2IP	TMR1IP	1111 1111	1111 1111
TMR1L	Timer1 Register Low Byte								xxxx xxxx	uuuu uuuu
TMR1H	Timer1 Register High Byte								xxxx xxxx	uuuu uuuu
T1CON	RD16	—	T1CKPS1	T1CKPS0	T1OSCEN	T1SYNC	TMR1CS	TMR1ON	0-00 0000	u-uu uuuu

Legend: x = unknown, u = unchanged, — = unimplemented, read as '0'. Shaded cells are not used by the Timer1 module.

Note 1: Enabled only in Microcontroller mode for PIC18F8525/8621 devices.

PIC18F6525/6621/8525/8621

NOTES:

PIC18F6525/6621/8525/8621

13.0 TIMER2 MODULE

The Timer2 module timer has the following features:

- 8-bit timer (TMR2 register)
- 8-bit period register (PR2)
- Readable and writable (both registers)
- Software programmable prescaler (1:1, 1:4, 1:16)
- Software programmable postscaler (1:1 to 1:16)
- Interrupt on TMR2 match of PR2
- MSSP module optional use of TMR2 output to generate clock shift

Timer2 has a control register shown in Register 13-1. Timer2 can be shut off by clearing control bit TMR2ON (T2CON<2>) to minimize power consumption. Figure 13-1 is a simplified block diagram of the Timer2 module. Register 13-1 shows the Timer2 Control register. The prescaler and postscaler selection of Timer2 are controlled by this register.

13.1 Timer2 Operation

Timer2 can be used as the PWM time base for the PWM mode of the ECCP module. The TMR2 register is readable and writable and is cleared on any device Reset. The input clock (Fosc/4) has a prescale option of 1:1, 1:4 or 1:16, selected by control bits T2CKPS1:T2CKPS0 (T2CON<1:0>). The match output of TMR2 goes through a 4-bit postscaler (which gives a 1:1 to 1:16 scaling inclusive) to generate a TMR2 interrupt, latched in flag bit TMR2IF (PIR1<1>).

The prescaler and postscaler counters are cleared when any of the following occurs:

- a write to the TMR2 register
- a write to the T2CON register
- any device Reset (Power-on Reset, $\overline{\text{MCLR}}$ Reset, Watchdog Timer Reset, or Brown-out Reset)

TMR2 is not cleared when T2CON is written.

REGISTER 13-1: T2CON: TIMER2 CONTROL REGISTER

U-0	R/W-0	R/W-0	R/W-0	R/W-0	R/W-0	R/W-0	R/W-0
—	T2OUTPS3	T2OUTPS2	T2OUTPS1	T2OUTPS0	TMR2ON	T2CKPS1	T2CKPS0
bit 7							bit 0

bit 7 **Unimplemented:** Read as '0'

bit 6-3 **T2OUTPS3:T2OUTPS0:** Timer2 Output Postscale Select bits

0000 = 1:1 Postscale

0001 = 1:2 Postscale

•

•

•

1111 = 1:16 Postscale

bit 2 **TMR2ON:** Timer2 On bit

1 = Timer2 is on

0 = Timer2 is off

bit 1-0 **T2CKPS1:T2CKPS0:** Timer2 Clock Prescale Select bits

00 = Prescaler is 1

01 = Prescaler is 4

1x = Prescaler is 16

Legend:

R = Readable bit

W = Writable bit

U = Unimplemented bit, read as '0'

-n = Value at POR

'1' = Bit is set

'0' = Bit is cleared

x = Bit is unknown

PIC18F6525/6621/8525/8621

13.2 Timer2 Interrupt

The Timer2 module has an 8-bit period register, PR2. Timer2 increments from 00h until it matches PR2 and then resets to 00h on the next increment cycle. PR2 is a readable and writable register. The PR2 register is initialized to FFh upon Reset.

13.3 Output of TMR2

The output of TMR2 (before the postscaler) is fed to the synchronous serial port module which optionally uses it to generate the shift clock.

FIGURE 13-1: TIMER2 BLOCK DIAGRAM

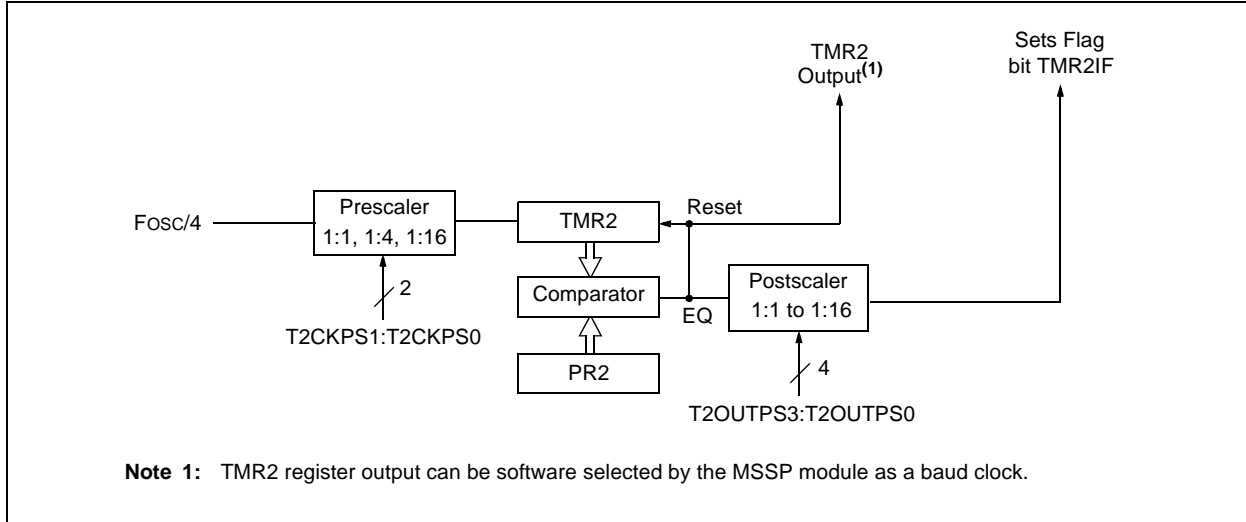

TABLE 13-1: REGISTERS ASSOCIATED WITH TIMER2 AS A TIMER/COUNTER

Name	Bit 7	Bit 6	Bit 5	Bit 4	Bit 3	Bit 2	Bit 1	Bit 0	Value on POR, BOR	Value on all other Resets
INTCON	GIE/GIEH	PEIE/GIEL	TMR0IE	INT0IE	RBIE	TMR0IF	INT0IF	RBIF	0000 000x	0000 000u
PIR1	PSPIF ⁽¹⁾	ADIF	RC1IF	TX1IF	SSPIF	CCP1IF	TMR2IF	TMR1IF	0000 0000	0000 0000
PIE1	PSPIE ⁽¹⁾	ADIE	RC1IE	TX1IE	SSPIE	CCP1IE	TMR2IE	TMR1IE	0000 0000	0000 0000
IPR1	PSPIP ⁽¹⁾	ADIP	RC1IP	TX1IP	SSPIP	CCP1IP	TMR2IP	TMR1IP	1111 1111	1111 1111
TMR2	Timer2 Module Register								0000 0000	0000 0000
T2CON	—	T2OUTPS3	T2OUTPS2	T2OUTPS1	T2OUTPS0	TMR2ON	T2CKPS1	T2CKPS0	-000 0000	-000 0000
PR2	Timer2 Period Register								1111 1111	1111 1111

Legend: x = unknown, u = unchanged, — = unimplemented, read as '0'. Shaded cells are not used by the Timer2 module.

Note 1: Enabled only in Microcontroller mode for PIC18F8525/8621 devices.

PIC18F6525/6621/8525/8621

14.0 TIMER3 MODULE

The Timer3 module timer/counter has the following features:

- 16-bit timer/counter (two 8-bit registers: TMR3H and TMR3L)
- Readable and writable (both registers)
- Internal or external clock select
- Interrupt-on-overflow from FFFFh to 0000h
- Reset from ECCP module trigger

Figure 14-1 is a simplified block diagram of the Timer3 module.

Register 14-1 shows the Timer3 Control register. This register controls the operating mode of the Timer3 module and sets the CCP/ECCP clock source.

Register 12-1 shows the Timer1 Control register. This register controls the operating mode of the Timer1 module, as well as contains the Timer1 oscillator enable bit (T1OSCEN) which can be a clock source for Timer3.

REGISTER 14-1: T3CON: TIMER3 CONTROL REGISTER

R/W-0	R/W-0	R/W-0	R/W-0	R/W-0	R/W-0	R/W-0	R/W-0
RD16	T3CCP2	T3CKPS1	T3CKPS0	T3CCP1	T3SYNC	TMR3CS	TMR3ON
bit 7							bit 0

- bit 7 **RD16:** 16-bit Read/Write Mode Enable bit
 1 = Enables register read/write of Timer3 in one 16-bit operation
 0 = Enables register read/write of Timer3 in two 8-bit operations
- bit 6,3 **T3CCP2:T3CCP1:** Timer3 and Timer1 to CCPx Enable bits
 11 = Timer3 and Timer4 are the clock sources for ECCP1 through CCP5
 10 = Timer3 and Timer4 are the clock sources for ECCP3 through CCP5;
 Timer1 and Timer2 are the clock sources for ECCP1 and ECCP2
 01 = Timer3 and Timer4 are the clock sources for ECCP2 through CCP5;
 Timer1 and Timer2 are the clock sources for ECCP1
 00 = Timer1 and Timer2 are the clock sources for ECCP1 through CCP5
- bit 5-4 **T3CKPS1:T3CKPS0:** Timer3 Input Clock Prescale Select bits
 11 = 1:8 Prescale value
 10 = 1:4 Prescale value
 01 = 1:2 Prescale value
 00 = 1:1 Prescale value
- bit 2 **T3SYNC:** Timer3 External Clock Input Synchronization Control bit
 (Not usable if the system clock comes from Timer1/Timer3)
When TMR3CS = 1:
 1 = Do not synchronize external clock input
 0 = Synchronize external clock input
When TMR3CS = 0:
 This bit is ignored. Timer3 uses the internal clock when TMR3CS = 0.
- bit 1 **TMR3CS:** Timer3 Clock Source Select bit
 1 = External clock input from Timer1 oscillator or T13CKI
 (on the rising edge after the first falling edge)
 0 = Internal clock (Fosc/4)
- bit 0 **TMR3ON:** Timer3 On bit
 1 = Enables Timer3
 0 = Stops Timer3

Legend:

R = Readable bit	W = Writable bit	U = Unimplemented bit, read as '0'
-n = Value at POR	'1' = Bit is set	'0' = Bit is cleared x = Bit is unknown

PIC18F6525/6621/8525/8621

14.1 Timer3 Operation

Timer3 can operate in one of these modes:

- As a timer
- As a synchronous counter
- As an asynchronous counter

The operating mode is determined by the clock select bit, TMR3CS (T3CON<1>).

When TMR3CS = 0, Timer3 increments every instruction cycle. When TMR3CS = 1, Timer3 increments on every rising edge of the Timer1 external clock input or the Timer1 oscillator, if enabled.

When the Timer1 oscillator is enabled (T1OSCEN is set), the RC1/T1OSI and RC0/T1OSO/T13CKI pins become inputs. That is, the TRISC<1:0> value is ignored and the pins are read as '0'.

Timer3 also has an internal "Reset input". This Reset can be generated by the ECCP module (**Section 14.0 "Timer3 Module"**).

FIGURE 14-1: TIMER3 BLOCK DIAGRAM

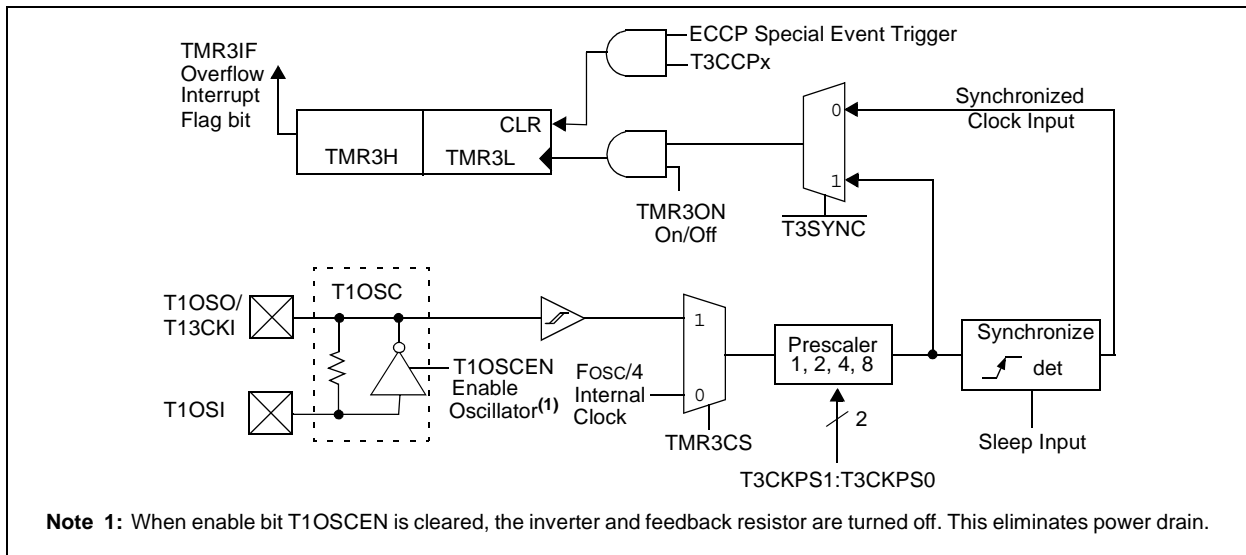
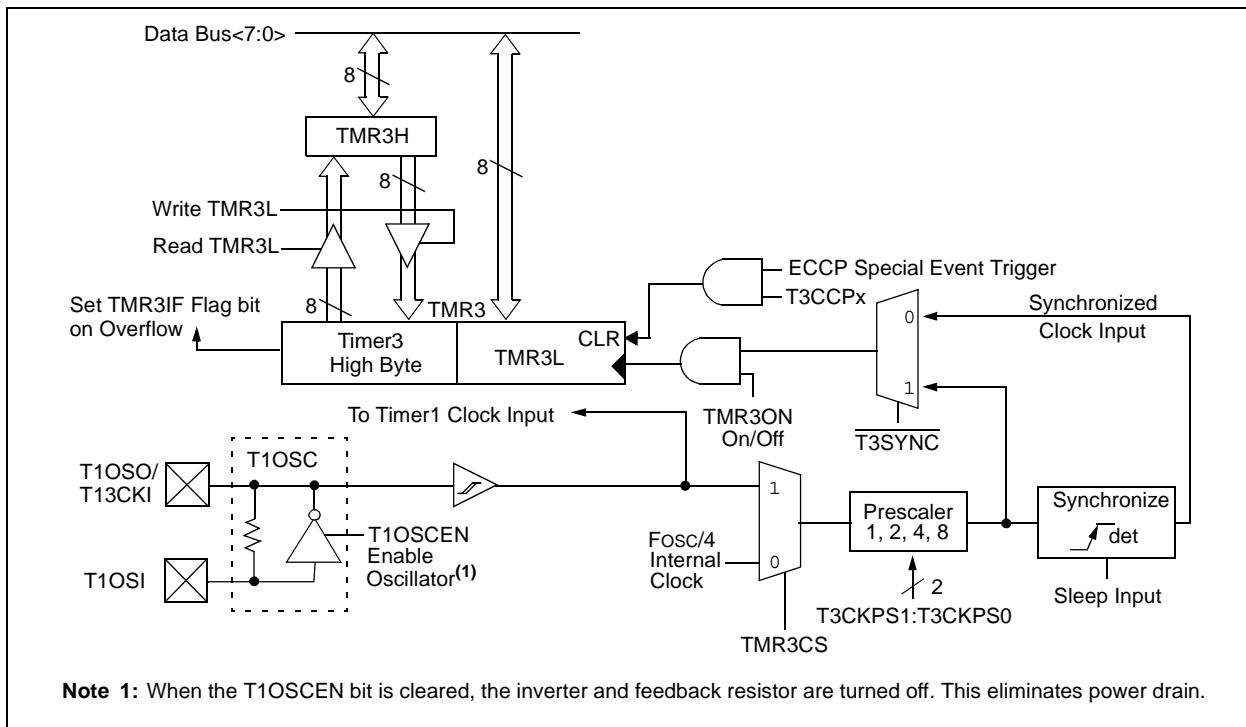

FIGURE 14-2: TIMER3 BLOCK DIAGRAM CONFIGURED IN 16-BIT READ/WRITE MODE



PIC18F6525/6621/8525/8621

14.2 Timer1 Oscillator

The Timer1 oscillator may be used as the clock source for Timer3. The Timer1 oscillator is enabled by setting the T1OSCEN (T1CON<3>) bit. The oscillator is a low-power oscillator rated up to 200 kHz. See **Section 12.0 “Timer1 Module”** for further details.

14.3 Timer3 Interrupt

The TMR3 register pair (TMR3H:TMR3L) increments from 0000h to FFFFh and rolls over to 0000h. The TMR3 interrupt, if enabled, is generated on overflow which is latched in interrupt flag bit, TMR3IF (PIR2<1>). This interrupt can be enabled/disabled by setting/clearing TMR3 interrupt enable bit, TMR3IE (PIE2<1>).

14.4 Resetting Timer3 Using an ECCP Special Trigger Output

If either the ECCP1 or ECCP2 module is configured in Compare mode to generate a special event trigger (CCP1M3:CCP1M0 = 1011), this signal will reset Timer3.

Note: The special event triggers from the ECCP module will not set interrupt flag bit, TMR3IF (PIR1<0>).

Timer3 must be configured for either Timer or Synchronized Counter mode to take advantage of this feature. If Timer3 is running in Asynchronous Counter mode, this Reset operation may not work. In the event that a write to Timer3 coincides with a special event trigger from ECCP1, the write will take precedence. In this mode of operation, the CCPR1H:CCPR1L register pair effectively becomes the period register for Timer3.

TABLE 14-1: REGISTERS ASSOCIATED WITH TIMER3 AS A TIMER/COUNTER

Name	Bit 7	Bit 6	Bit 5	Bit 4	Bit 3	Bit 2	Bit 1	Bit 0	Value on POR, BOR	Value on all other Resets
INTCON	GIE/ GIEH	PEIE/ GIEL	TMR0IE	INTOIE	RBIE	TMR0IF	INT0IF	RBIF	0000 000x	0000 000u
PIR2	—	CMIF	—	EEIF	BCLIF	LVDIF	TMR3IF	CCP2IF	-0-0 0000	-0-0 0000
PIE2	—	CMIE	—	EEIE	BCLIE	LVDIE	TMR3IE	CCP2IE	-0-0 0000	-0-0 0000
IPR2	—	CMIP	—	EEIP	BCLIP	LVDIP	TMR3IP	CCP2IP	-1-1 1111	-1-1 1111
TMR3L	Timer3 Register Low Byte								xxxx xxxx	uuuu uuuu
TMR3H	Timer3 Register High Byte								xxxx xxxx	uuuu uuuu
T1CON	RD16	—	T1CKPS1	T1CKPS0	T1OSCEN	T1SYNC	TMR1CS	TMR1ON	0-00 0000	u-uu uuuu
T3CON	RD16	T3CCP2	T3CKPS1	T3CKPS0	T3CCP1	T3SYNC	TMR3CS	TMR3ON	0000 0000	uuuu uuuu

Legend: x = unknown, u = unchanged, — = unimplemented, read as '0'. Shaded cells are not used by the Timer3 module.

PIC18F6525/6621/8525/8621

NOTES:

PIC18F6525/6621/8525/8621

15.0 TIMER4 MODULE

The Timer4 module timer has the following features:

- 8-bit timer (TMR4 register)
- 8-bit period register (PR4)
- Readable and writable (both registers)
- Software programmable prescaler (1:1, 1:4, 1:16)
- Software programmable postscaler (1:1 to 1:16)
- Interrupt on TMR4 match of PR4

Timer4 has a control register shown in Register 15-1. Timer4 can be shut off by clearing control bit, TMR4ON (T4CON<2>), to minimize power consumption. The prescaler and postscaler selection of Timer4 are also controlled by this register. Figure 15-1 is a simplified block diagram of the Timer4 module.

15.1 Timer4 Operation

Timer4 can be used as the PWM time base for the PWM mode of the CCP module. The TMR4 register is readable and writable and is cleared on any device Reset. The input clock ($F_{osc}/4$) has a prescale option of 1:1, 1:4 or 1:16, selected by control bits T4CKPS1:T4CKPS0 (T4CON<1:0>). The match output of TMR4 goes through a 4-bit postscaler (which gives a 1:1 to 1:16 scaling inclusive) to generate a TMR4 interrupt, latched in flag bit TMR4IF (PIR3<3>).

The prescaler and postscaler counters are cleared when any of the following occurs:

- a write to the TMR4 register
- a write to the T4CON register
- any device Reset (Power-on Reset, \overline{MCLR} Reset, Watchdog Timer Reset, or Brown-out Reset)

TMR4 is not cleared when T4CON is written.

REGISTER 15-1: T4CON: TIMER4 CONTROL REGISTER

U-0	R/W-0	R/W-0	R/W-0	R/W-0	R/W-0	R/W-0	R/W-0
—	T4OUTPS3	T4OUTPS2	T4OUTPS1	T4OUTPS0	TMR4ON	T4CKPS1	T4CKPS0
bit 7							bit 0

bit 7 **Unimplemented:** Read as '0'

bit 6-3 **T4OUTPS3:T4OUTPS0:** Timer4 Output Postscale Select bits

0000 = 1:1 Postscale

0001 = 1:2 Postscale

•

•

•

1111 = 1:16 Postscale

bit 2 **TMR4ON:** Timer4 On bit

1 = Timer4 is on

0 = Timer4 is off

bit 1-0 **T4CKPS1:T4CKPS0:** Timer4 Clock Prescale Select bits

00 = Prescaler is 1

01 = Prescaler is 4

1x = Prescaler is 16

Legend:

R = Readable bit

W = Writable bit

U = Unimplemented bit, read as '0'

-n = Value at POR

'1' = Bit is set

'0' = Bit is cleared

x = Bit is unknown

PIC18F6525/6621/8525/8621

15.2 Timer4 Interrupt

The Timer4 module has an 8-bit period register, PR4, which is both readable and writable. Timer4 increments from 00h until it matches PR4 and then resets to 00h on the next increment cycle. The PR4 register is initialized to FFh upon Reset.

15.3 Output of TMR4

The output of TMR4 (before the postscaler) is used only as a PWM time base for the CCP modules. It is not used as a baud rate clock for the MSSP, as is the Timer2 output.

FIGURE 15-1: TIMER4 BLOCK DIAGRAM

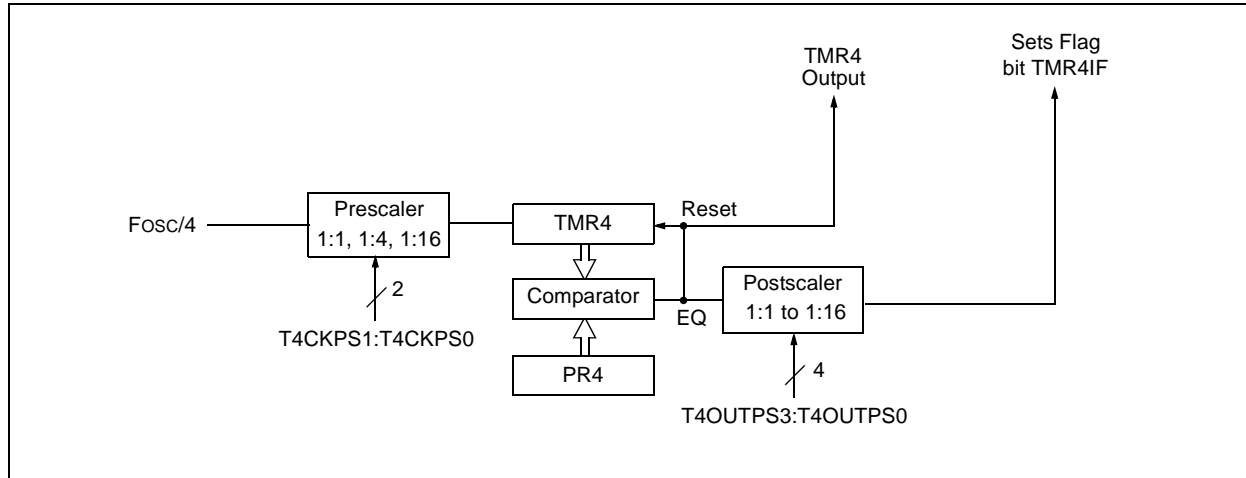

TABLE 15-1: REGISTERS ASSOCIATED WITH TIMER4 AS A TIMER/COUNTER

Name	Bit 7	Bit 6	Bit 5	Bit 4	Bit 3	Bit 2	Bit 1	Bit 0	Value on POR, BOR	Value on all other Resets
INTCON	GIE/GIEH	PEIE/GIEL	TMR0IE	INT0IE	RBIE	TMR0IF	INT0IF	RBIF	0000 000x	0000 000u
IPR3	—	—	RC2IP	TX2IP	TMR4IP	CCP5IP	CCP4IP	CCP3IP	--11 1111	--00 0000
PIR3	—	—	RC2IF	TX2IF	TMR4IF	CCP5IF	CCP4IF	CCP3IF	--00 0000	--00 0000
PIE3	—	—	RC2IE	TX2IE	TMR4IE	CCP5IE	CCP4IE	CCP3IE	--00 0000	--00 0000
TMR4	Timer4 Register								0000 0000	0000 0000
T4CON	—	T4OUTPS3	T4OUTPS2	T4OUTPS1	T4OUTPS0	TMR4ON	T4CKPS1	T4CKPS0	-000 0000	-000 0000
PR4	Timer4 Period Register								1111 1111	1111 1111

Legend: x = unknown, u = unchanged, — = unimplemented, read as '0'. Shaded cells are not used by the Timer4 module.

PIC18F6525/6621/8525/8621

16.0 CAPTURE/COMPARE/PWM (CCP) MODULES

PIC18F6525/6621/8525/8621 devices all have a total of five CCP (Capture/Compare/PWM) modules. Two of these (CCP4 and CCP5) implement standard Capture, Compare and Pulse-Width Modulation (PWM) modes and are discussed in this section. The other three modules (ECCP1, ECCP2, ECCP3) implement standard Capture and Compare modes, as well as Enhanced PWM modes. These are discussed in **Section 17.0 “Enhanced Capture/Compare/PWM (ECCP) Module”**.

Each CCP/ECCP module contains a 16-bit register which can operate as a 16-bit Capture register, a 16-bit Compare register or a PWM Master/Slave Duty Cycle register. For the sake of clarity, all CCP module operation in the following sections is described with respect to CCP4, but is equally applicable to CCP5.

Capture and Compare operations described in this chapter apply to all standard and Enhanced CCP modules. The operations of PWM mode described in **Section 16.4 “PWM Mode”** apply to CCP4 and CCP5 only.

Note: Throughout this section and **Section 17.0 “Enhanced Capture/Compare/PWM (ECCP) Module”**, references to register and bit names that may be associated with a specific CCP module are referred to generically by the use of ‘x’ or ‘y’ in place of the specific module number. Thus, “CCPxCON” might refer to the control register for CCP4 or CCP5, or ECCP1, ECCP2 or ECCP3. “CCPxCON” is used throughout these sections to refer to the module control register, regardless of whether the CCP module is a standard or Enhanced implementation.

REGISTER 16-1: CCPxCON REGISTER (CCP4 AND CCP5 MODULES)

	U-0	U-0	R/W-0	R/W-0	R/W-0	R/W-0	R/W-0	R/W-0
	—	—	DCxB1	DCxB0	CCPxM3	CCPxM2	CCPxM1	CCPxM0
bit 7								bit 0

bit 7-6 **Unimplemented:** Read as ‘0’

bit 5-4 **DCxB1:DCxB0:** PWM Duty Cycle bit 1 and bit 0 for CCP Module x

Capture mode:

Unused.

Compare mode:

Unused.

PWM mode:

These bits are the two Least Significant bits (bit 1 and bit 0) of the 10-bit PWM duty cycle. The eight Most Significant bits (DCx9:DCx2) of the duty cycle are found in CCPRxL.

bit 3-0 **CCPxM3:CCPxM0:** CCP Module x Mode Select bits

0000 = Capture/Compare/PWM disabled (resets CCPx module)

0001 = Reserved

0010 = Compare mode, toggle output on match (CCPxIF bit is set)

0011 = Reserved

0100 = Capture mode, every falling edge

0101 = Capture mode, every rising edge

0110 = Capture mode, every 4th rising edge

0111 = Capture mode, every 16th rising edge

1000 = Compare mode; initialize CCP pin low; on compare match, force CCP pin high (CCPIF bit is set)

1001 = Compare mode; initialize CCP pin high; on compare match, force CCP pin low (CCPIF bit is set)

1010 = Compare mode; generate software interrupt on compare match (CCPIF bit is set, CCP pin reflects I/O state)

1011 = Reserved

11xx = PWM mode

Legend:

R = Readable bit

W = Writable bit

U = Unimplemented bit, read as ‘0’

-n = Value at POR

‘1’ = Bit is set

‘0’ = Bit is cleared

x = Bit is unknown

PIC18F6525/6621/8525/8621

16.1 CCP Module Configuration

Each Capture/Compare/PWM module is associated with a control register (generically, CCPxCON) and a data register (CCPRx). The data register in turn is comprised of two 8-bit registers: CCPRxL (low byte) and CCPRxH (high byte). All registers are both readable and writable.

16.1.1 CCP MODULES AND TIMER RESOURCES

The CCP/ECCP modules utilize Timers 1, 2, 3 or 4, depending on the mode selected. Timer1 and Timer3 are available to modules in Capture or Compare modes, while Timer2 and Timer4 are available for modules in PWM mode.

TABLE 16-1: CCP MODE – TIMER RESOURCE

CCP Mode	Timer Resource
Capture	Timer1 or Timer3
Compare	Timer1 or Timer3
PWM	Timer2 or Timer4

The assignment of a particular timer to a module is determined by the Timer-to-CCP enable bits in the T3CON register (Register 14-1, page 143). Depending on the configuration selected, up to four timers may be active at once, with modules in the same configuration (Capture/Compare or PWM) sharing timer resources. The possible configurations are shown in Figure 16-1.

FIGURE 16-1: CCP AND TIMER INTERCONNECT CONFIGURATIONS

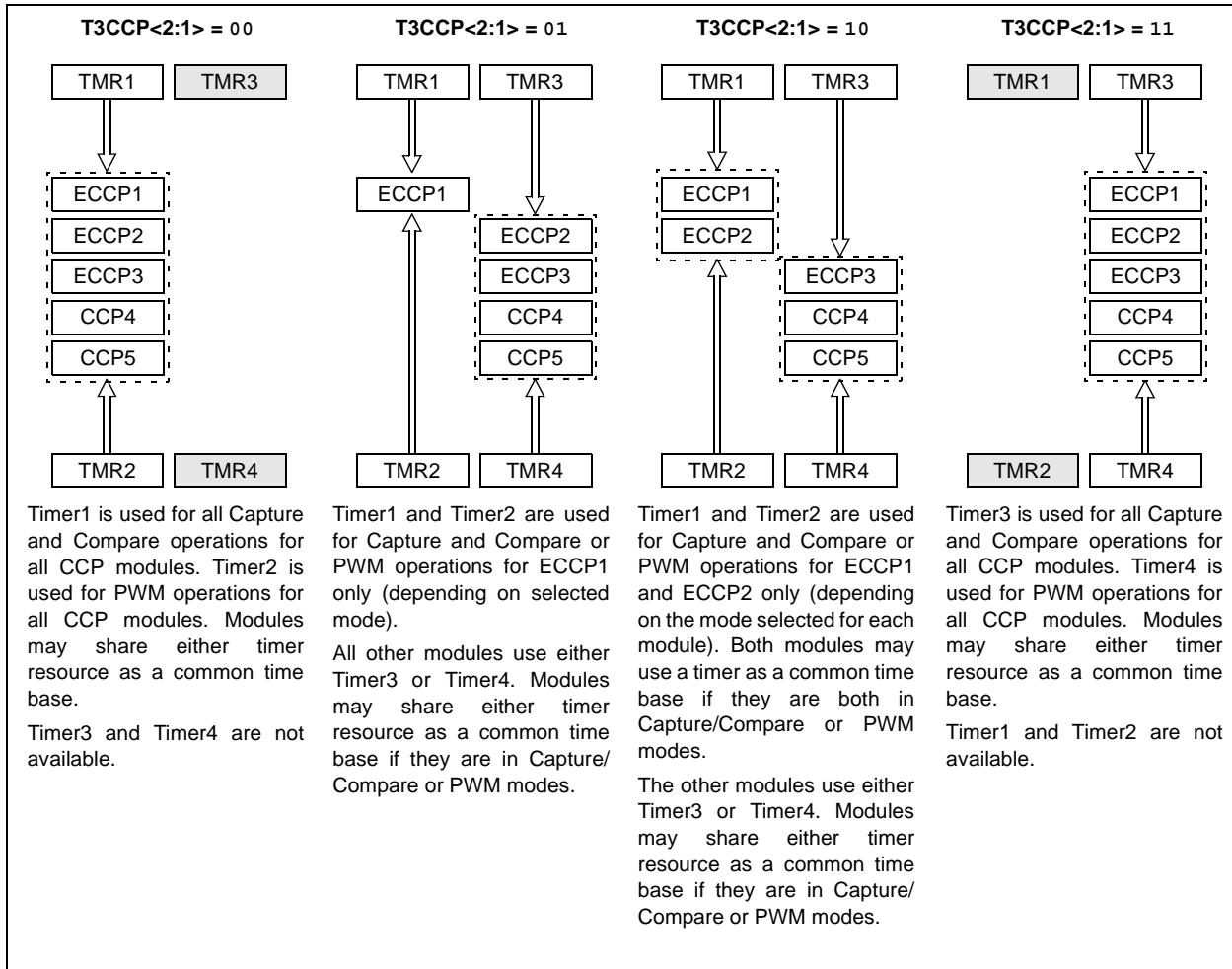

16.2 Capture Mode

In Capture mode, the CCPR4H:CCPR4L register pair captures the 16-bit value of the TMR1 or TMR3 registers when an event occurs on pin RG3/CCP4/P1D. An event is defined as one of the following:

- every falling edge
- every rising edge
- every 4th rising edge
- every 16th rising edge

The event is selected by the mode select bits, CCP4M3:CCP4M0 (CCP4CON<3:0>). When a capture is made, the interrupt request flag bit CCP4IF (PIR3<1>) is set; it must be cleared in software. If another capture occurs before the value in register CCPR4 is read, the old captured value is overwritten by the new captured value.

16.2.1 CCP PIN CONFIGURATION

In Capture mode, the RG3/CCP4/P1D pin should be configured as an input by setting the TRISG<3> bit.

Note: If the RG3/CCP4/P1D is configured as an output, a write to the port can cause a capture condition.

16.2.2 TIMER1/TIMER3 MODE SELECTION

The timers that are to be used with the capture feature (Timer1 and/or Timer3) must be running in Timer mode or Synchronized Counter mode. In Asynchronous Counter mode, the capture operation may not work. The timer to be used with each CCP module is selected in the T3CON register (see **Section 16.1.1 “CCP Modules and Timer Resources”**).

16.2.3 SOFTWARE INTERRUPT

When the Capture mode is changed, a false capture interrupt may be generated. The user should keep bit CCP4IE (PIE3<1>) clear to avoid false interrupts and should clear the flag bit, CCP4IF, following any such change in operating mode.

16.2.4 CCP PRESCALER

There are four prescaler settings in Capture mode; they are specified as part of the operating mode selected by the mode select bits (CCP4M3:CCP4M0). Whenever the CCP module is turned off or the CCP module is not in Capture mode, the prescaler counter is cleared. This means that any Reset will clear the prescaler counter.

Switching from one capture prescaler to another may generate an interrupt. Also, the prescaler counter will not be cleared; therefore, the first capture may be from a non-zero prescaler. Example 16-1 shows the recommended method for switching between capture prescalers. This example also clears the prescaler counter and will not generate the “false” interrupt.

EXAMPLE 16-1: CHANGING BETWEEN CAPTURE PRESCALERS

```

CLRf   CCP4CON    ; Turn CCP module off
MOVLW  NEW_CAPT_PS ; Load WREG with the
                    ; new prescaler mode
                    ; value and CCP ON
MOVWF  CCP4CON    ; Load CCP1CON with
                    ; this value
    
```

FIGURE 16-2: CAPTURE MODE OPERATION BLOCK DIAGRAM

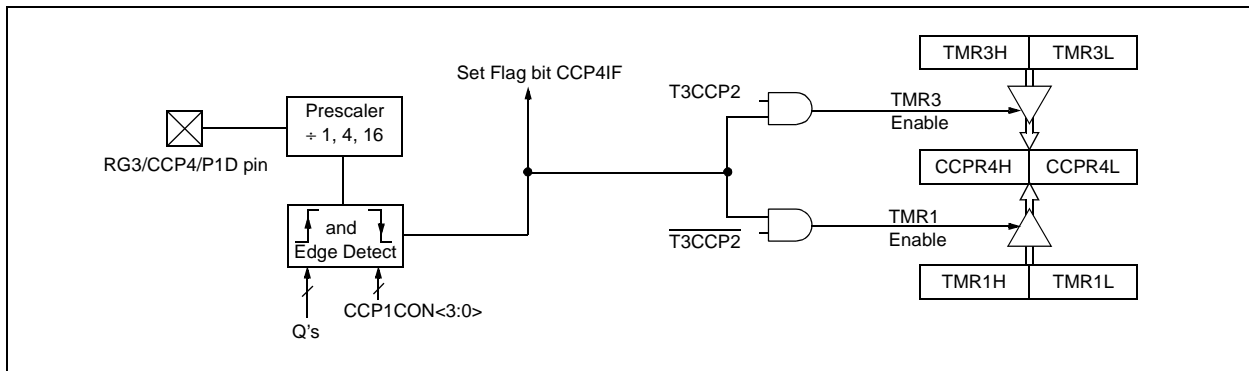

PIC18F6525/6621/8525/8621

16.3 Compare Mode

In Compare mode, the 16-bit CCPR1 register value is constantly compared against either the TMR1 or TMR3 register pair value. When a match occurs, the CCP4 pin can be:

- driven high
- driven low
- toggled (high-to-low or low-to-high)
- remain unchanged (that is, reflects the state of the I/O latch)

The action on the pin is based on the value of the mode select bits (CCP4M3:CCP4M0). At the same time, the interrupt flag bit CCP4IF is set.

16.3.1 CCP PIN CONFIGURATION

The user must configure the CCPx pin as an output by clearing the appropriate TRIS bit.

Note: Clearing the CCP4CON register will force the RG3/CCP4/P1D compare output latch to the default low level. This is not the PORTG I/O data latch.

16.3.2 TIMER1/TIMER3 MODE SELECTION

Timer1 and/or Timer3 must be running in Timer mode or Synchronized Counter mode, if the CCP module is using the compare feature. In Asynchronous Counter mode, the compare operation may not work.

16.3.3 SOFTWARE INTERRUPT MODE

When the Generate Software Interrupt mode is chosen (CCP4M3:CCP4M0 = 1010), the CCP4 pin is not affected. Only a CCP interrupt is generated if enabled and the CCP4IE bit is set.

16.3.4 SPECIAL EVENT TRIGGER

Although shown in Figure 16-3, the compare on match special event triggers are not implemented on CCP4 or CCP5; they are only available on ECCP1 and ECCP2. Their operation is discussed in detail in **Section 17.2.1 "Special Event Trigger"**.

FIGURE 16-3: COMPARE MODE OPERATION BLOCK DIAGRAM

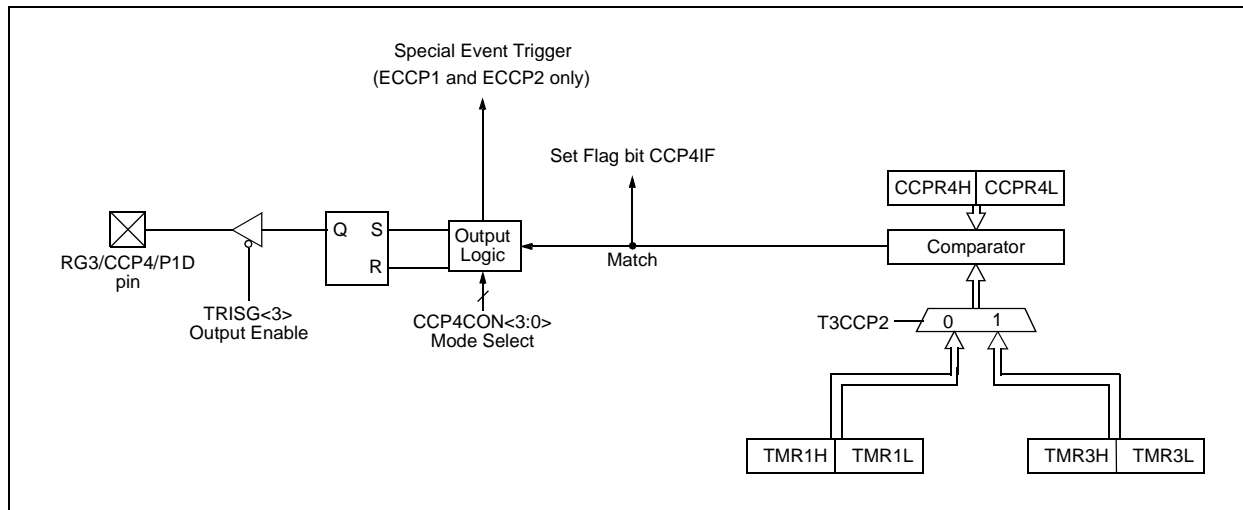

PIC18F6525/6621/8525/8621

TABLE 16-2: REGISTERS ASSOCIATED WITH CAPTURE, COMPARE, TIMER1 AND TIMER3

Name	Bit 7	Bit 6	Bit 5	Bit 4	Bit 3	Bit 2	Bit 1	Bit 0	Value on POR, BOR	Value on all other Resets
INTCON	GIE/GIEH	PEIE/GIEL	TMR0IE	INT0IE	RBIE	TMR0IF	INT0IF	RBIF	0000 000x	0000 000u
RCON	IPEN	—	—	\overline{RI}	\overline{TO}	\overline{PD}	\overline{POR}	\overline{BOR}	0--1 11qq	0--q qquu
PIR1	PSPIF ⁽¹⁾	ADIF	RC1IF	TX1IF	SSPIF	CCP1IF	TMR2IF	TMR1IF	0000 0000	0000 0000
PIE1	PSPIE ⁽¹⁾	ADIE	RC1IE	TX1IE	SSPIE	CCP1IE	TMR2IE	TMR1IE	0000 0000	0000 0000
IPR1	PSPIP ⁽¹⁾	ADIP	RC1IP	TX1IP	SSPIP	CCP1IP	TMR2IP	TMR1IP	1111 1111	1111 1111
PIR2	—	CMIF	—	EEIF	BCLIF	LVDIF	TMR3IF	CCP2IF	-0-0 0000	---0 0000
PIE2	—	CMIE	—	EEIE	BCLIE	LVDIE	TMR3IE	CCP2IE	-0-0 0000	---0 0000
IPR2	—	CMIP	—	EEIP	BCLIP	LVDIP	TMR3IP	CCP2IP	-1-1 1111	---1 1111
PIR3	—	—	RC2IF	TX2IF	TMR4IF	CCP5IF	CCP4IF	CCP3IF	--00 0000	--00 0000
PIE3	—	—	RC2IE	TX2IE	TMR4IE	CCP5IE	CCP4IE	CCP3IE	--00 0000	--00 0000
IPR3	—	—	RC2IP	TX2IP	TMR4IP	CCP5IP	CCP4IP	CCP3IP	--11 1111	--11 1111
TRISB	PORTB Data Direction Register								1111 1111	1111 1111
TRISC	PORTC Data Direction Register								1111 1111	1111 1111
TRISE	PORTE Data Direction Register								1111 1111	1111 1111
TRISG	—	—	—	PORTG Data Direction Register				---	1111	---1 1111
TMR1L	Timer1 Register Low Byte								xxxx xxxx	uuuu uuuu
TMR1H	Timer1 Register High Byte								xxxx xxxx	uuuu uuuu
T1CON	RD16	—	T1CKPS1	T1CKPS0	T1OSCEN	$\overline{T1SYNC}$	TMR1CS	TMR1ON	0-00 0000	u-uu uuuu
TMR3H	Timer3 Register High Byte								xxxx xxxx	uuuu uuuu
TMR3L	Timer3 Register Low Byte								xxxx xxxx	uuuu uuuu
T3CON	RD16	T3CCP2	T3CKPS1	T3CKPS0	T3CCP1	$\overline{T3SYNC}$	TMR3CS	TMR3ON	0000 0000	uuuu uuuu
CCPR1L	Enhanced Capture/Compare/PWM Register 1 Low Byte								xxxx xxxx	uuuu uuuu
CCPR1H	Enhanced Capture/Compare/PWM Register 1 High Byte								xxxx xxxx	uuuu uuuu
CCP1CON	P1M1	P1M0	DC1B1	DC1B0	CCP1M3	CCP1M2	CCP1M1	CCP1M0	0000 0000	0000 0000
CCPR2L	Enhanced Capture/Compare/PWM Register 2 Low Byte								xxxx xxxx	uuuu uuuu
CCPR2H	Enhanced Capture/Compare/PWM Register 2 High Byte								xxxx xxxx	uuuu uuuu
CCP2CON	P2M1	P2M0	DC2B1	DC2B0	CCP2M3	CCP2M2	CCP2M1	CCP2M0	0000 0000	0000 0000
CCPR3L	Enhanced Capture/Compare/PWM Register 3 Low Byte								xxxx xxxx	uuuu uuuu
CCPR3H	Enhanced Capture/Compare/PWM Register 3 High Byte								xxxx xxxx	uuuu uuuu
CCP3CON	P3M1	P3M0	DC3B1	DC3B0	CCP3M3	CCP3M2	CCP3M1	CCP3M0	0000 0000	0000 0000
CCPR4L	Capture/Compare/PWM Register 4 Low Byte								xxxx xxxx	uuuu uuuu
CCPR4H	Capture/Compare/PWM Register 4 High Byte								xxxx xxxx	uuuu uuuu
CCP4CON	—	—	DC4B1	DC4B0	CCP4M3	CCP4M2	CCP4M1	CCP4M0	--00 0000	--00 0000
CCPR5L	Capture/Compare/PWM Register 5 Low Byte								xxxx xxxx	uuuu uuuu
CCPR5H	Capture/Compare/PWM Register 5 High Byte								xxxx xxxx	uuuu uuuu
CCP5CON	—	—	DC5B1	DC5B0	CCP5M3	CCP5M2	CCP5M1	CCP5M0	--00 0000	--00 0000

Legend: x = unknown, u = unchanged, — = unimplemented, read as '0'.
 Shaded cells are not used by Capture and Compare, Timer1 or Timer3.

Note 1: Enabled only in Microcontroller mode for PIC18F8525/8621 devices.

PIC18F6525/6621/8525/8621

16.4 PWM Mode

In Pulse-Width Modulation (PWM) mode, the CCP4 pin produces up to a 10-bit resolution PWM output. Since the CCP4 pin is multiplexed with the PORTG data latch, the TRISG<3> bit must be cleared to make the CCP4 pin an output.

Note: Clearing the CCP4CON register will force the CCP4 PWM output latch to the default low level. This is not the PORTG I/O data latch.

Figure 16-4 shows a simplified block diagram of the CCP module in PWM mode.

For a step-by-step procedure on how to set up the CCP module for PWM operation, see **Section 16.4.3 “Setup for PWM Operation”**.

FIGURE 16-4: SIMPLIFIED PWM BLOCK DIAGRAM

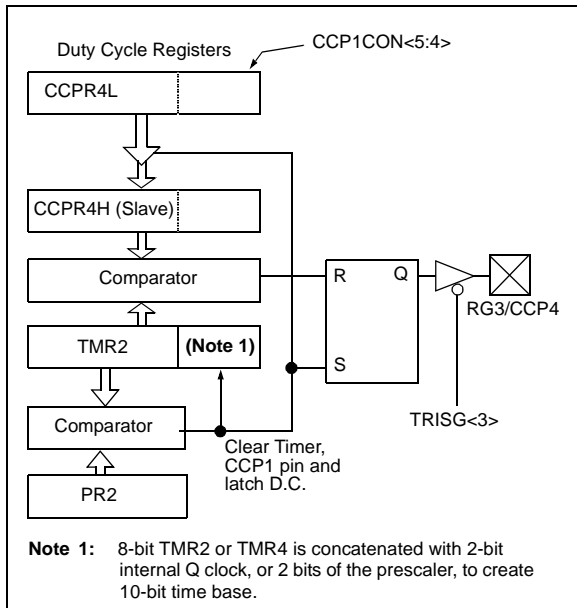

A PWM output (Figure 16-5) has a time base (period) and a time that the output stays high (duty cycle). The frequency of the PWM is the inverse of the period (1/period).

FIGURE 16-5: PWM OUTPUT

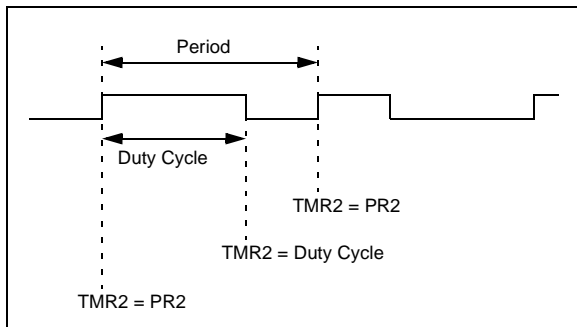

16.4.1 PWM PERIOD

The PWM period is specified by writing to the PR2 (PR4) register. The PWM period can be calculated using the following formula:

EQUATION 16-1:

$$\text{PWM Period} = [(PR2) + 1] \cdot 4 \cdot \text{Tosc} \cdot (\text{TMR2 Prescale Value})$$

PWM frequency is defined as 1/[PWM period].

When TMR2 (TMR4) is equal to PR2 (PR2), the following three events occur on the next increment cycle:

- TMR2 (TMR4) is cleared
- The CCP4 pin is set (exception: if PWM duty cycle = 0%, the CCP4 pin will not be set)
- The PWM duty cycle is latched from CCPR4L into CCPR4H

Note: The Timer2 and Timer4 postscale (see **Section 13.0 “Timer2 Module”**) are not used in the determination of the PWM frequency. The postscale could be used to have a servo update rate at a different frequency than the PWM output.

16.4.2 PWM DUTY CYCLE

The PWM duty cycle is specified by writing to the CCPR4L register and to the CCP4CON<5:4> bits. Up to 10-bit resolution is available. The CCPR4L contains the eight MSBs and the CCP4CON<5:4> contains the two LSBs. This 10-bit value is represented by CCPR4L:CCP4CON<5:4>. The following equation is used to calculate the PWM duty cycle in time:

EQUATION 16-2:

$$\text{PWM Duty Cycle} = (\text{CCPR4L:CCP4CON<5:4>}) \cdot \text{Tosc} \cdot (\text{TMR2 Prescale Value})$$

CCPR4L and CCP4CON<5:4> can be written to at any time, but the duty cycle value is not latched into CCPR4H until after a match between PR2 and TMR2 occurs (i.e., the period is complete). In PWM mode, CCPR4H is a read-only register.

The CCPR4H register and a 2-bit internal latch are used to double-buffer the PWM duty cycle. This double-buffering is essential for glitchless PWM operation.

When the CCPR4H and 2-bit latch match TMR2, concatenated with an internal 2-bit Q clock or 2 bits of the TMR2 prescaler, the CCP4 pin is cleared.

PIC18F6525/6621/8525/8621

The maximum PWM resolution (bits) for a given PWM frequency is given by the equation:

EQUATION 16-3:

$$\text{PWM Resolution (max)} = \frac{\log\left(\frac{F_{\text{OSC}}}{F_{\text{PWM}}}\right)}{\log(2)} \text{ bits}$$

Note: If the PWM duty cycle value is longer than the PWM period, the CCP4 pin will not be cleared.

16.4.3 SETUP FOR PWM OPERATION

The following steps should be taken when configuring the CCP module for PWM operation:

1. Select TMR2 or TMR4 by setting or clearing the T3CCP2:T3CCP1 bits in the T3CON register.
2. Set the PWM period by writing to the PR2 or PR4 register
3. Set the PWM duty cycle by writing to the CCPR4L register and CCP4CON<5:4> bits.
4. Make the CCP4 pin an output by clearing the TRISG<3> bit.
5. Set TMR2 or TMR4 prescale value, enable Timer2 or Timer4 by writing to T2CON or T4CON.
6. Configure the CCP4 module for PWM operation.

TABLE 16-3: EXAMPLE PWM FREQUENCIES AND RESOLUTIONS AT 40 MHz

PWM Frequency	2.44 kHz	9.77 kHz	39.06 kHz	156.25 kHz	312.50 kHz	416.67 kHz
Timer Prescaler (1, 4, 16)	16	4	1	1	1	1
PR2 Value	FFh	FFh	FFh	3Fh	1Fh	17h
Maximum Resolution (bits)	14	12	10	8	7	6.58

PIC18F6525/6621/8525/8621

TABLE 16-4: REGISTERS ASSOCIATED WITH PWM, TIMER2 AND TIMER4

Name	Bit 7	Bit 6	Bit 5	Bit 4	Bit 3	Bit 2	Bit 1	Bit 0	Value on POR, BOR	Value on all other Resets
INTCON	GIE/GIEH	PEIE/GIEL	TMR0IE	INT0IE	RBIE	TMR0IF	INT0IF	RBIF	0000 000x	0000 000u
RCON	IPEN	—	—	\overline{RI}	\overline{TO}	\overline{PD}	\overline{POR}	\overline{BOR}	0--1 11qq	0--q qquu
PIR1	PSPIF ⁽¹⁾	ADIF	RC1IF	TX1IF	SSPIF	CCP1IF	TMR2IF	TMR1IF	0000 0000	0000 0000
PIE1	PSPIE ⁽¹⁾	ADIE	RC1IE	TX1IE	SSPIE	CCP1IE	TMR2IE	TMR1IE	0000 0000	0000 0000
IPR1	PSPIP ⁽¹⁾	ADIP	RC1IP	TX1IP	SSPIP	CCP1IP	TMR2IP	TMR1IP	1111 1111	1111 1111
PIR2	—	CMIF	—	EEIF	BCLIF	LVDIF	TMR3IF	CCP2IF	-0-0 0000	---0 0000
PIE2	—	CMIE	—	EEIE	BCLIE	LVDIE	TMR3IE	CCP2IE	-0-0 0000	---0 0000
IPR2	—	CMIP	—	EEIP	BCLIP	LVDIP	TMR3IP	CCP2IP	-1-1 1111	---1 1111
PIR3	—	—	RC2IF	TX2IF	TMR4IF	CCP5IF	CCP4IF	CCP3IF	--00 0000	--00 0000
PIE3	—	—	RC2IE	TX2IE	TMR4IE	CCP5IE	CCP4IE	CCP3IE	--00 0000	--00 0000
IPR3	—	—	RC2IP	TX2IP	TMR4IP	CCP5IP	CCP4IP	CCP3IP	--11 1111	--11 1111
TMR2	Timer2 Register								0000 0000	0000 0000
PR2	Timer2 Period Register								1111 1111	1111 1111
T2CON	—	T2OUTPS3	T2OUTPS2	T2OUTPS1	T2OUTPS0	TMR2ON	T2CKPS1	T2CKPS0	-000 0000	-000 0000
T3CON	RD16	T3CCP2	T3CKPS1	T3CKPS0	T3CCP1	$\overline{T3SYNC}$	TMR3CS	TMR3ON	0000 0000	uuuu uuuu
TMR4	Timer4 Register								0000 0000	uuuu uuuu
PR4	Timer4 Period Register								1111 1111	uuuu uuuu
T4CON	—	T4OUTPS3	T4OUTPS2	T4OUTPS1	T4OUTPS0	TMR4ON	T4CKPS1	T4CKPS0	-000 0000	uuuu uuuu
CCPR1L	Enhanced Capture/Compare/PWM Register 1 Low Byte								xxxx xxxx	uuuu uuuu
CCPR1H	Enhanced Capture/Compare/PWM Register 1 High Byte								xxxx xxxx	uuuu uuuu
CCP1CON	P1M1	P1M0	DC1B1	DC1B0	CCP1M3	CCP1M2	CCP1M1	CCP1M0	0000 0000	0000 0000
CCPR2L	Enhanced Capture/Compare/PWM Register 2 Low Byte								xxxx xxxx	uuuu uuuu
CCPR2H	Enhanced Capture/Compare/PWM Register 2 High Byte								xxxx xxxx	uuuu uuuu
CCP2CON	P2M1	P2M0	DC2B1	DC2B0	CCP2M3	CCP2M2	CCP2M1	CCP2M0	0000 0000	0000 0000
CCPR3L	Enhanced Capture/Compare/PWM Register 3 Low Byte								xxxx xxxx	uuuu uuuu
CCPR3H	Enhanced Capture/Compare/PWM Register 3 High Byte								xxxx xxxx	uuuu uuuu
CCP3CON	P3M1	P3M0	DC3B1	DC3B0	CCP3M3	CCP3M2	CCP3M1	CCP3M0	0000 0000	0000 0000
CCPR4L	Capture/Compare/PWM Register 4 Low Byte								xxxx xxxx	uuuu uuuu
CCPR4H	Capture/Compare/PWM Register 4 High Byte								xxxx xxxx	uuuu uuuu
CCP4CON	—	—	DC4B1	DC4B0	CCP4M3	CCP4M2	CCP4M1	CCP4M0	--00 0000	--00 0000
CCPR5L	Capture/Compare/PWM Register 5 Low Byte								xxxx xxxx	uuuu uuuu
CCPR5H	Capture/Compare/PWM Register 5 High Byte								xxxx xxxx	uuuu uuuu
CCP5CON	—	—	DC5B1	DC5B0	CCP5M3	CCP5M2	CCP5M1	CCP5M0	--00 0000	--00 0000

Legend: x = unknown, u = unchanged, — = unimplemented, read as '0'. Shaded cells are not used by PWM, Timer2 or Timer4.

Note 1: Enabled only in Microcontroller mode for PIC18F8525/8621 devices.

PIC18F6525/6621/8525/8621

17.0 ENHANCED CAPTURE/ COMPARE/PWM (ECCP) MODULE

The Enhanced CCP (ECCP) modules differ from the standard CCP modules by the addition of Enhanced PWM capabilities. These allow for 2 or 4 output channels, user selectable polarity, dead-band control and automatic shutdown and restart and are discussed in detail in **Section 17.4 “Enhanced PWM Mode”**. Except for the addition of the special event trigger,

Capture and Compare functions of the ECCP module are the same as the standard CCP module.

The prototype control register for the Enhanced CCP module is shown in Register 17-1. In addition to the expanded range of modes available through the CCPxCON register, the ECCP modules each have two additional registers associated with Enhanced PWM operation and auto-shutdown features. They are:

- ECCPxDEL (Dead-Band Delay)
- ECCPxAS (Auto-Shutdown Configuration)

REGISTER 17-1: CCPxCON REGISTER (ECCP1, ECCP2 AND ECCP3 MODULES)

R/W-0	R/W-0	R/W-0	R/W-0	R/W-0	R/W-0	R/W-0	R/W-0	
PxM1	PxM0	DCxB1	DCxB0	CCPxM3	CCPxM2	CCPxM1	CCPxM0	
bit 7								bit 0

bit 7-6 **PxM1:PxM0:** Enhanced PWM Output Configuration bits

If CCPxM3:CCPxM2 = 00, 01, 10:

xx = PxA assigned as Capture/Compare input/output; PxB, PxC, PxD assigned as port pins

If CCPxM3:CCPxM2 = 11:

00 = Single output: PxA modulated; PxB, PxC, PxD assigned as port pins

01 = Full-bridge output forward: P1D modulated; P1A active; P1B, P1C inactive

10 = Half-bridge output: P1A, P1B modulated with dead-band control; P1C, P1D assigned as port pins

11 = Full-bridge output reverse: P1B modulated; P1C active; P1A, P1D inactive

bit 5-4 **DCxB1:DCxB0:** PWM Duty Cycle bit 1 and bit 0

Capture mode:

Unused.

Compare mode:

Unused.

PWM mode:

These bits are the two LSbs of the 10-bit PWM duty cycle. The eight MSbs of the duty cycle are found in CCPRxL.

bit 3-0 **CCPxM3:CCPxM0:** Enhanced CCP Mode Select bits

0000 = Capture/Compare/PWM off (resets ECCPx module)

0001 = Reserved

0010 = Compare mode, toggle output on match

0011 = Capture mode

0100 = Capture mode, every falling edge

0101 = Capture mode, every rising edge

0110 = Capture mode, every 4th rising edge

0111 = Capture mode, every 16th rising edge

1000 = Compare mode, initialize ECCP pin low, set output on compare match (set CCPxIF)

1001 = Compare mode, initialize ECCP pin high, clear output on compare match (set CCPxIF)

1010 = Compare mode, generate software interrupt only, ECCP pin reverts to I/O state

1011 = Compare mode, trigger special event (ECCP resets TMR1 or TMR3, sets CCxIF bit, ECCP2 trigger starts A/D conversion if A/D module is enabled)⁽¹⁾

1100 = PWM mode; PxA, PxC active-high; PxB, PxD active-high

1101 = PWM mode; PxA, PxC active-high; PxB, PxD active-low

1110 = PWM mode; PxA, PxC active-low; PxB, PxD active-high

1111 = PWM mode; PxA, PxC active-low; PxB, PxD active-low

Note 1: Implemented only for ECCP1 and ECCP2; same as '1010' for ECCP3.

Legend:

R = Readable bit

W = Writable bit

U = Unimplemented bit, read as '0'

-n = Value at POR

'1' = Bit is set

'0' = Bit is cleared

x = Bit is unknown

PIC18F6525/6621/8525/8621

17.1 ECCP Outputs and Configuration

Each of the Enhanced CCP modules may have up to four PWM outputs, depending on the selected operating mode. These outputs, designated PxA through PxD, are multiplexed with various I/O pins. Some ECCP pin assignments are constant, while others change based on device configuration. For those pins that do change, the controlling bits are:

- CCP2MX configuration bit (CONFIG3H<0>)
- ECCPMX configuration bit (CONFIG3H<1>)
- Program Memory mode (set by configuration bits CONFIG3L<1:0>)

The pin assignments for the Enhanced CCP modules are summarized in Table 17-1, Table 17-2 and Table 17-3. To configure the I/O pins as PWM outputs, the proper PWM mode must be selected by setting the P_xM_x and CCP_xM_x bits (CCP_xCON<7:6> and <3:0>, respectively). The appropriate TRIS direction bits for the corresponding port pins must also be set as outputs.

17.1.1 USE OF CCP4 AND CCP5 WITH ECCP1 AND ECCP3

Only the ECCP2 module has four dedicated output pins available for use. Assuming that the I/O ports or other multiplexed functions on those pins are not needed, they may be used whenever needed without interfering with any other CCP module.

ECCP1 and ECCP3, on the other hand, only have three dedicated output pins: ECCP_x/P_xA, P_xB and P_xC. Whenever these modules are configured for Quad PWM mode, the pin normally used for CCP4 or CCP5 becomes the D output pins for ECCP3 and ECCP1, respectively. The CCP4 and CCP5 modules remain functional but their outputs are overridden.

17.1.2 ECCP MODULE OUTPUTS AND PROGRAM MEMORY MODES

For PIC18F8525/8621 devices, the Program Memory mode of the device (**Section 4.1.1 “PIC18F6525/6621/8525/8621 Program Memory Modes”**) impacts both pin multiplexing and the operation of the module.

The ECCP2 input/output (ECCP2/P2A) can be multiplexed to one of three pins. By default, this is RC1 for all devices. In this case, the default occurs when CCP2MX is set and the device is operating in Microcontroller mode. With PIC18F8525/8621 devices, three other options exist. When CCP2MX is not set (= 0) and the device is in Microcontroller mode, ECCP2/P2A is multiplexed to RE7; in all other program memory modes, it is multiplexed to RB3.

The final option is for CCP2MX to be set while the device is operating in one of the three other program memory modes. In this case, ECCP1 and ECCP3 operate as compatible (i.e., single output) CCP modules. The pins used by their other outputs (P_xB through P_xD) are available for other multiplexed functions. ECCP2 continues to operate as an Enhanced CCP module regardless of the program memory mode.

TABLE 17-1: PIN CONFIGURATIONS FOR ECCP1

ECCP Mode	CCP1CON Configuration	RC2	RE6	RE5	RG4	RH7	RH6
All PIC18F6525/6621 devices:							
Compatible CCP	00xx 11xx	ECCP1	RE6	RE5	RG4/CCP5	N/A	N/A
Dual PWM	10xx 11xx	P1A	P1B	RE5	RG4/CCP5	N/A	N/A
Quad PWM	x1xx 11xx	P1A	P1B	P1C	P1D	N/A	N/A
PIC18F8525/8621 devices, ECCPMX = 1, Microcontroller mode:							
Compatible CCP	00xx 11xx	ECCP1	RE6/AD14	RE5/AD13	RG4/CCP5	RH7/AN15	RH6/AN14
Dual PWM	10xx 11xx	P1A	P1B	RE5/AD13	RG4/CCP5	RH7/AN15	RH6/AN14
Quad PWM	x1xx 11xx	P1A	P1B	P1C	P1D	RH7/AN15	RH6/AN14
PIC18F8525/8621 devices, ECCPMX = 0, Microcontroller mode:							
Compatible CCP	00xx 11xx	ECCP1	RE6/AD14	RE5/AD13	RG4/CCP5	RH7/AN15	RH6/AN14
Dual PWM	10xx 11xx	P1A	RE6/AD14	RE5/AD13	RG4/CCP5	P1B	RH6/AN14
Quad PWM	x1xx 11xx	P1A	RE6/AD14	RE5/AD13	P1D	P1B	P1C
PIC18F8525/8621 devices, ECCPMX = 1, all other Program Memory modes:							
Compatible CCP	00xx 11xx	ECCP1	RE6/AD14	RE5/AD13	RG4/CCP5	RH7/AN15	RH6/AN14

Legend: x = Don't care, N/A = Not available. Shaded cells indicate pin assignments not used by ECCP1 in a given mode.

Note 1: With ECCP1 in Quad PWM mode, CCP5's output is overridden by P1D; otherwise CCP5 is fully operational.

PIC18F6525/6621/8525/8621

TABLE 17-2: PIN CONFIGURATIONS FOR ECCP2

ECCP Mode	CCP2CON Configuration	RB3	RC1	RE7	RE2	RE1	RE0
All devices, CCP2MX = 1, Microcontroller mode:							
Compatible CCP	00xx 11xx	RB3/INT3	ECCP2	RE7	RE2	RE1	RE0
Dual PWM	10xx 11xx	RB3/INT3	P2A	RE7	P2B	RE1	RE0
Quad PWM	x1xx 11xx	RB3/INT3	P2A	RE7	P2B	P2C	P2D
All devices, CCP2MX = 0, Microcontroller mode:							
Compatible CCP	00xx 11xx	RB3/INT3	RC1/T1OS1	ECCP2	RE2	RE1	RE0
Dual PWM	10xx 11xx	RB3/INT3	RC1/T1OS1	P2A	P2B	RE1	RE0
Quad PWM	x1xx 11xx	RB3/INT3	RC1/T1OS1	P2A	P2B	P2C	P2D
PIC18F8525/8621 devices, CCP2MX = 0, all other Program Memory modes:							
Compatible CCP	00xx 11xx	ECCP2	RC1/T1OS1	RE7/AD15	RE2/ \overline{CS}	RE1/ \overline{WR}	RE0/ \overline{RD}
Dual PWM	10xx 11xx	P2A	RC1/T1OS1	RE7/AD15	P2B	RE1/ \overline{WR}	RE0/ \overline{RD}
Quad PWM	x1xx 11xx	P2A	RC1/T1OS1	RE7/AD15	P2B	P2C	P2D

Legend: x = Don't care. Shaded cells indicate pin assignments not used by ECCP2 in a given mode.

TABLE 17-3: PIN CONFIGURATIONS FOR ECCP3

ECCP Mode	CCP3CON Configuration	RG0	RE4	RE3	RG3	RH5	RH4
All PIC18F6525/6621 devices:							
Compatible CCP	00xx 11xx	ECCP3	RE4	RE3	RG3/CCP4	N/A	N/A
Dual PWM	10xx 11xx	P3A	P3B	RE3	RG3/CCP4	N/A	N/A
Quad PWM	x1xx 11xx	P3A	P3B	P3C	P3D	N/A	N/A
PIC18F8525/8621 devices, ECCPMX = 1, Microcontroller mode:							
Compatible CCP	00xx 11xx	ECCP3	RE4/AD12	RE3/AD11	RG3/CCP4	RH5/AN13	RH4/AN12
Dual PWM	10xx 11xx	P3A	P3B	RE3/AD11	RG3/CCP4	RH5/AN13	RH4/AN12
Quad PWM	x1xx 11xx	P3A	P3B	P3C	P3D	RH5/AN13	RH4/AN12
PIC18F8525/8621 devices, ECCPMX = 0, Microcontroller mode:							
Compatible CCP	00xx 11xx	ECCP3	RE6/AD14	RE5/AD13	RG3/CCP4	RH7/AN15	RH6/AN14
Dual PWM	10xx 11xx	P3A	RE6/AD14	RE5/AD13	RG3/CCP4	P3B	RH6/AN14
Quad PWM	x1xx 11xx	P3A	RE6/AD14	RE5/AD13	P3D	P3B	P3C
PIC18F8525/8621 devices, ECCPMX = 1, all other Program Memory modes:							
Compatible CCP	00xx 11xx	ECCP3	RE6/AD14	RE5/AD13	RG3/CCP4	RH7/AN15	RH6/AN14

Legend: x = Don't care, N/A = Not available. Shaded cells indicate pin assignments not used by ECCP3 in a given mode.

Note 1: With ECCP3 in Quad PWM mode, CCP4's output is overridden by P1D; otherwise CCP4 is fully operational.

PIC18F6525/6621/8525/8621

17.1.3 ECCP MODULES AND TIMER RESOURCES

Like the standard CCP modules, the ECCP modules can utilize Timers 1, 2, 3 or 4, depending on the mode selected. Timer1 and Timer3 are available for modules in Capture or Compare modes, while Timer2 and Timer4 are available for modules in PWM mode. Additional details on timer resources are provided in **Section 16.1.1 “CCP Modules and Timer Resources”**.

17.2 Capture and Compare Modes

Except for the operation of the special event trigger discussed below, the Capture and Compare modes of the ECCP module are identical in operation to that of CCP4. These are discussed in detail in **Section 16.2 “Capture Mode”** and **Section 16.3 “Compare Mode”**.

17.2.1 SPECIAL EVENT TRIGGER

In this mode, an internal hardware trigger is generated in Compare mode, on a match between the CCPR register pair and the selected timer. This can be used in turn to initiate an action.

The special event trigger output of either ECCP1 or ECCP2 resets the TMR1 or TMR3 register pair, depending on which timer resource is currently selected. This allows the CCPRx register to effectively be a 16-bit programmable period register for Timer1 or Timer3. In addition, the ECCP2 special event trigger will also start an A/D conversion if the A/D module is enabled.

The triggers are not implemented for ECCP3, CCP4 or CCP5. Selecting the Special Event mode (CCPxM3:CCPxM0 = 1011) for these modules has the same effect as selecting the Compare with Software Interrupt mode (CCPxM3:CCPxM0 = 1010).

Note: The special event trigger from ECCP2 will not set the Timer1 or Timer3 interrupt flag bits.

17.3 Standard PWM Mode

When configured in Single Output mode, the ECCP module functions identically to the standard CCP module in PWM mode as described in **Section 16.4 “PWM Mode”**. This is also sometimes referred to as “Compatible CCP” mode as in Tables 17-1 through 17-3.

Note: When setting up single output PWM operations, users are free to use either of the processes described in **Section 16.4.3 “Setup for PWM Operation”** or **Section 17.4.9 “Setup for PWM Operation”**. The latter is more generic but will work for either single or multi-output PWM.

17.4 Enhanced PWM Mode

The Enhanced PWM mode provides additional PWM output options for a broader range of control applications. The module is a backward compatible version of the standard CCP module and offers up to four outputs, designated PxA through PxD. Users are also able to select the polarity of the signal (either active-high or active-low). The module's output mode and polarity are configured by setting the PxM1:PxM0 and CCPxM3CCPxM0 bits of the CCPxCON register (CCPxCON<7:6> and CCPxCON<3:0>, respectively).

For the sake of clarity, Enhanced PWM mode operation is described generically throughout this section with respect to ECCP1 and TMR2 modules. Control register names are presented in terms of ECCP1. All three Enhanced modules, as well as the two timer resources, can be used interchangeably and function identically. TMR2 or TMR4 can be selected for PWM operation by selecting the proper bits in T3CON.

Figure 17-1 shows a simplified block diagram of PWM operation. All control registers are double-buffered and are loaded at the beginning of a new PWM cycle (the period boundary when Timer2 resets) in order to prevent glitches on any of the outputs. The exception is the PWM Delay register, ECCP1DEL, which is loaded at either the duty cycle boundary or the boundary period (whichever comes first). Because of the buffering, the module waits until the assigned timer resets instead of starting immediately. This means that Enhanced PWM waveforms do not exactly match the standard PWM waveforms, but are instead offset by one full instruction cycle (4 TOSC).

As before, the user must manually configure the appropriate TRIS bits for output.

17.4.1 PWM PERIOD

The PWM period is specified by writing to the PR2 register. The PWM period can be calculated using the equation:

EQUATION 17-1:

$$\text{PWM Period} = [(\text{PR2}) + 1] \cdot 4 \cdot \text{Tosc} \cdot (\text{TMR2 Prescale Value})$$

PWM frequency is defined as 1/[PWM period]. When TMR2 is equal to PR2, the following three events occur on the next increment cycle:

- TMR2 is cleared
- The ECCP1 pin is set (if PWM duty cycle = 0%, the ECCP1 pin will not be set)
- The PWM duty cycle is copied from CCPR1L into CCPR1H

Note: The Timer2 postscaler (see **Section 13.0 “Timer2 Module”**) is not used in the determination of the PWM frequency. The postscaler could be used to have a servo update rate at a different frequency than the PWM output.

PIC18F6525/6621/8525/8621

FIGURE 17-1: SIMPLIFIED BLOCK DIAGRAM OF THE ENHANCED PWM MODULE

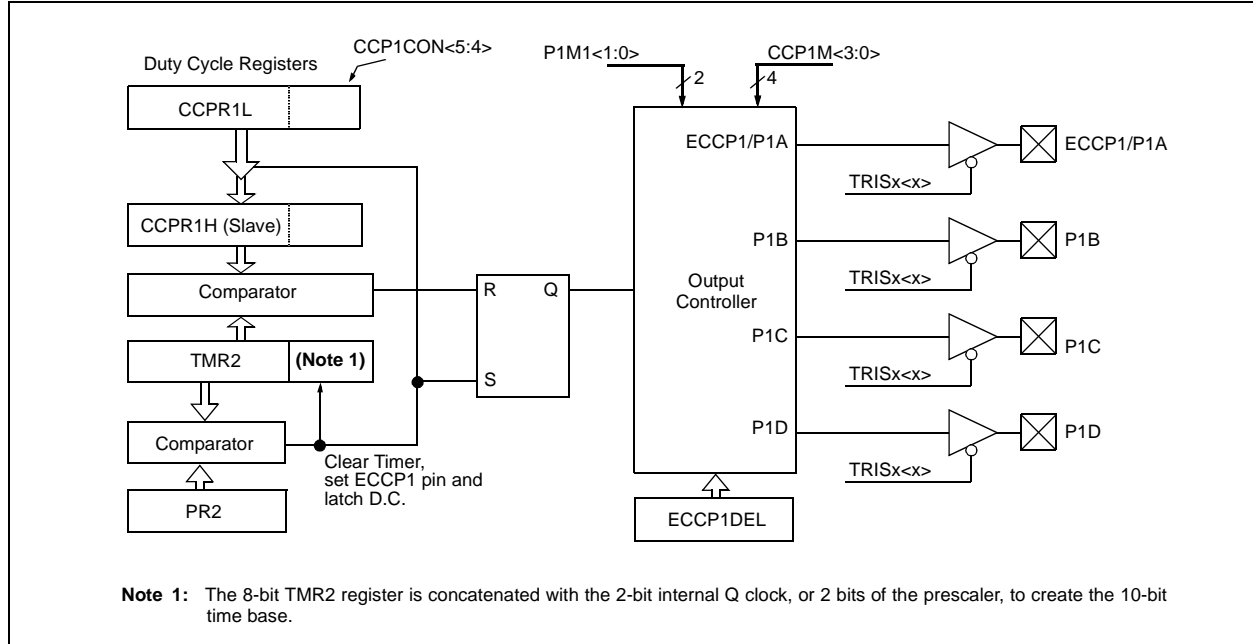

17.4.2 PWM DUTY CYCLE

The PWM duty cycle is specified by writing to the CCPR1L register and to the CCP1CON<5:4> bits. Up to 10-bit resolution is available. The CCPR1L contains the eight MSbs and the CCP1CON<5:4> contains the two LSbs. This 10-bit value is represented by CCPRxL:CCPxCON<5:4>. The PWM duty cycle is calculated by the equation:

EQUATION 17-2:

$$\text{PWM Duty Cycle} = (\text{CCPR1L:CCP1CON<5:4>}) \cdot \text{Tosc} \cdot (\text{TMR2 Prescale Value})$$

CCPR1L and CCP1CON<5:4> can be written to at any time but the duty cycle value is not copied into CCPR1H until a match between PR2 and TMR2 occurs (i.e., the period is complete). In PWM mode, CCPR1H is a read-only register.

The CCPRxH register and a 2-bit internal latch are used to double-buffer the PWM duty cycle. This double-buffering is essential for glitchless PWM operation. When the CCPR1H and 2-bit latch match TMR2, concatenated with an internal 2-bit Q clock or two bits of the TMR2 prescaler, the ECCP1 pin is cleared. The maximum PWM resolution (bits) for a given PWM frequency is given by the equation:

EQUATION 17-3:

$$\text{PWM Resolution (max)} = \frac{\log\left(\frac{F_{\text{OSC}}}{F_{\text{PWM}}}\right)}{\log(2)} \text{ bits}$$

Note: If the PWM duty cycle value is longer than the PWM period, the ECCP1 pin will not be cleared.

TABLE 17-4: EXAMPLE PWM FREQUENCIES AND RESOLUTIONS AT 40 MHz

PWM Frequency	2.44 kHz	9.77 kHz	39.06 kHz	156.25 kHz	312.50 kHz	416.67 kHz
Timer Prescaler (1, 4, 16)	16	4	1	1	1	1
PR2 Value	FFh	FFh	FFh	3Fh	1Fh	17h
Maximum Resolution (bits)	10	10	10	8	7	6.58

PIC18F6525/6621/8525/8621

17.4.3 PWM OUTPUT CONFIGURATIONS

The P1M1:P1M0 bits in the CCP1CON register allow one of four configurations:

- Single Output
- Half-Bridge Output
- Full-Bridge Output, Forward mode
- Full-Bridge Output, Reverse mode

The Single Output mode is the standard PWM mode discussed in **Section 17.4 “Enhanced PWM Mode”**. The Half-Bridge and Full-Bridge Output modes are covered in detail in the sections that follow.

The general relationship of the outputs in all configurations is summarized in Figure 17-2.

FIGURE 17-2: PWM OUTPUT RELATIONSHIPS (ACTIVE-HIGH STATE)

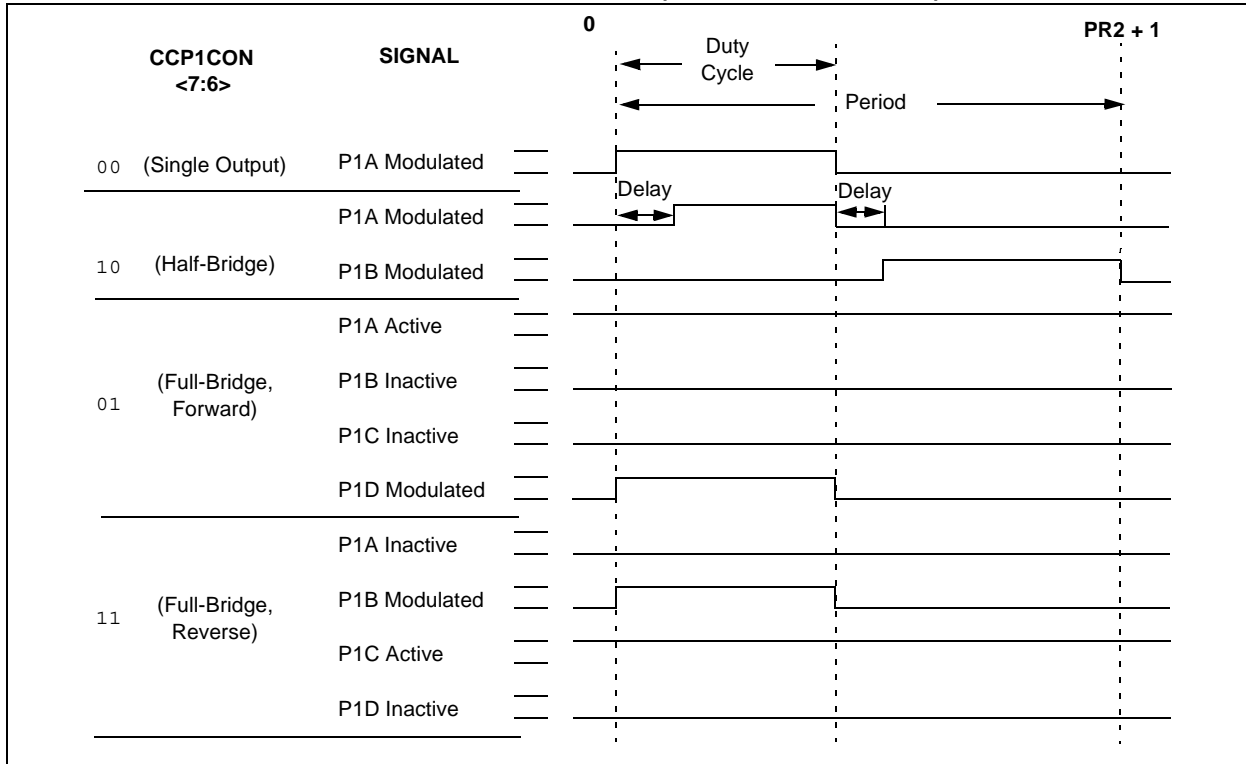
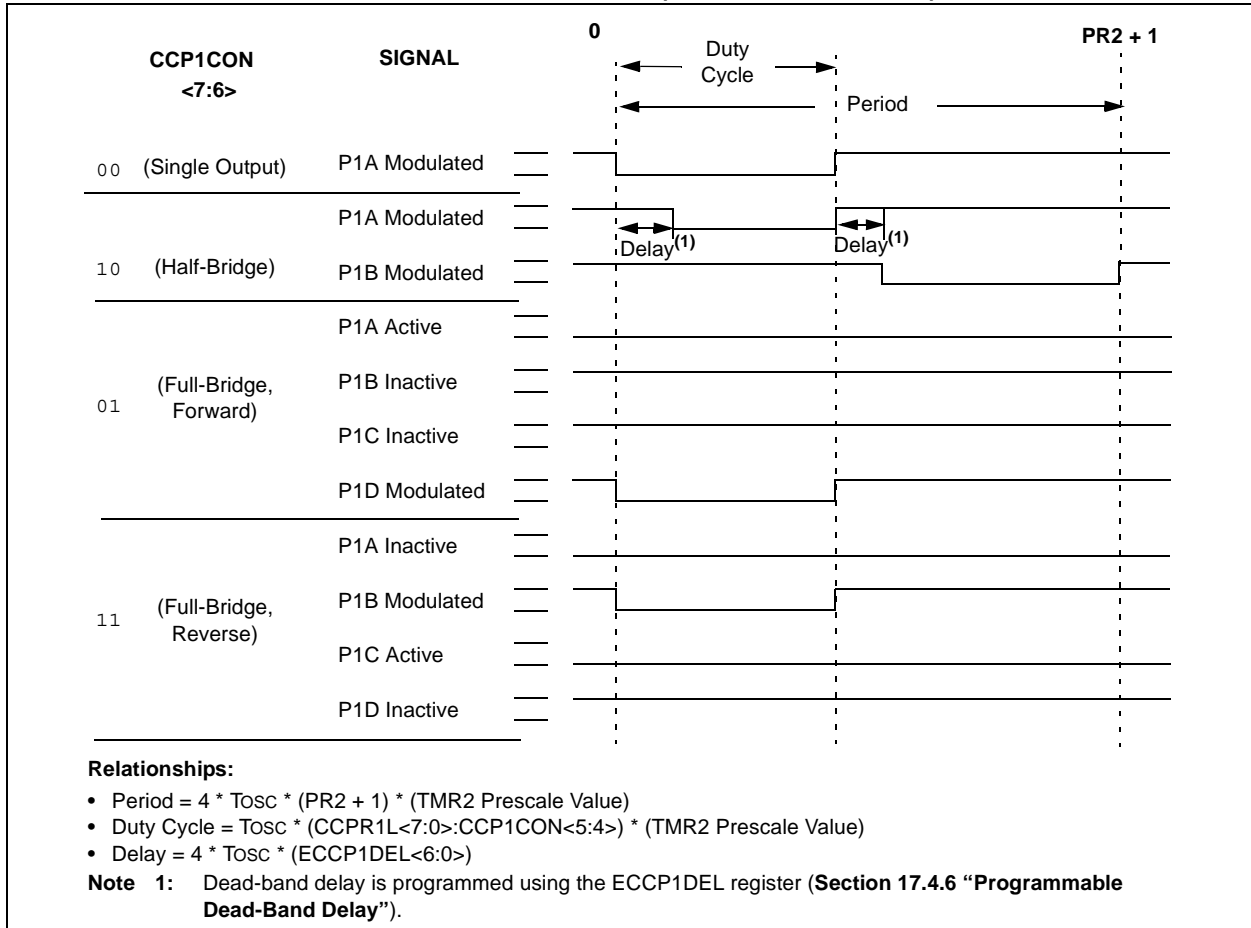

FIGURE 17-3: PWM OUTPUT RELATIONSHIPS (ACTIVE-LOW STATE)



17.4.4 HALF-BRIDGE MODE

In the Half-Bridge Output mode, two pins are used as outputs to drive push-pull loads. The PWM output signal is output on the P1A pin, while the complementary PWM output signal is output on the P1B pin (Figure 17-4). This mode can be used for half-bridge applications, as shown in Figure 17-5, or for full-bridge applications, where four power switches are being modulated with two PWM signals.

In Half-Bridge Output mode, the programmable dead-band delay can be used to prevent shoot-through current in half-bridge power devices. The value of bits PDC6:PDC0 sets the number of instruction cycles before the output is driven active. If the value is greater than the duty cycle, the corresponding output remains inactive during the entire cycle. See **Section 17.4.6 “Programmable Dead-Band Delay”** for more details on dead-band delay operations.

Since the P1A and P1B outputs are multiplexed with the PORTC<2> and PORTE<6> data latches, the TRISC<2> and TRISE<6> bits must be cleared to configure P1A and P1B as outputs.

FIGURE 17-4: HALF-BRIDGE PWM OUTPUT

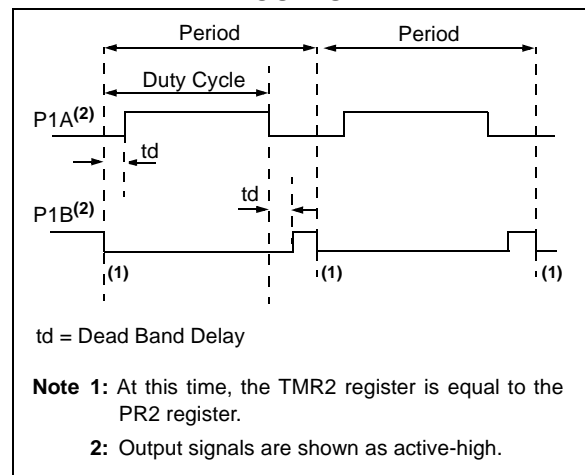

PIC18F6525/6621/8525/8621

FIGURE 17-5: EXAMPLES OF HALF-BRIDGE OUTPUT MODE APPLICATIONS

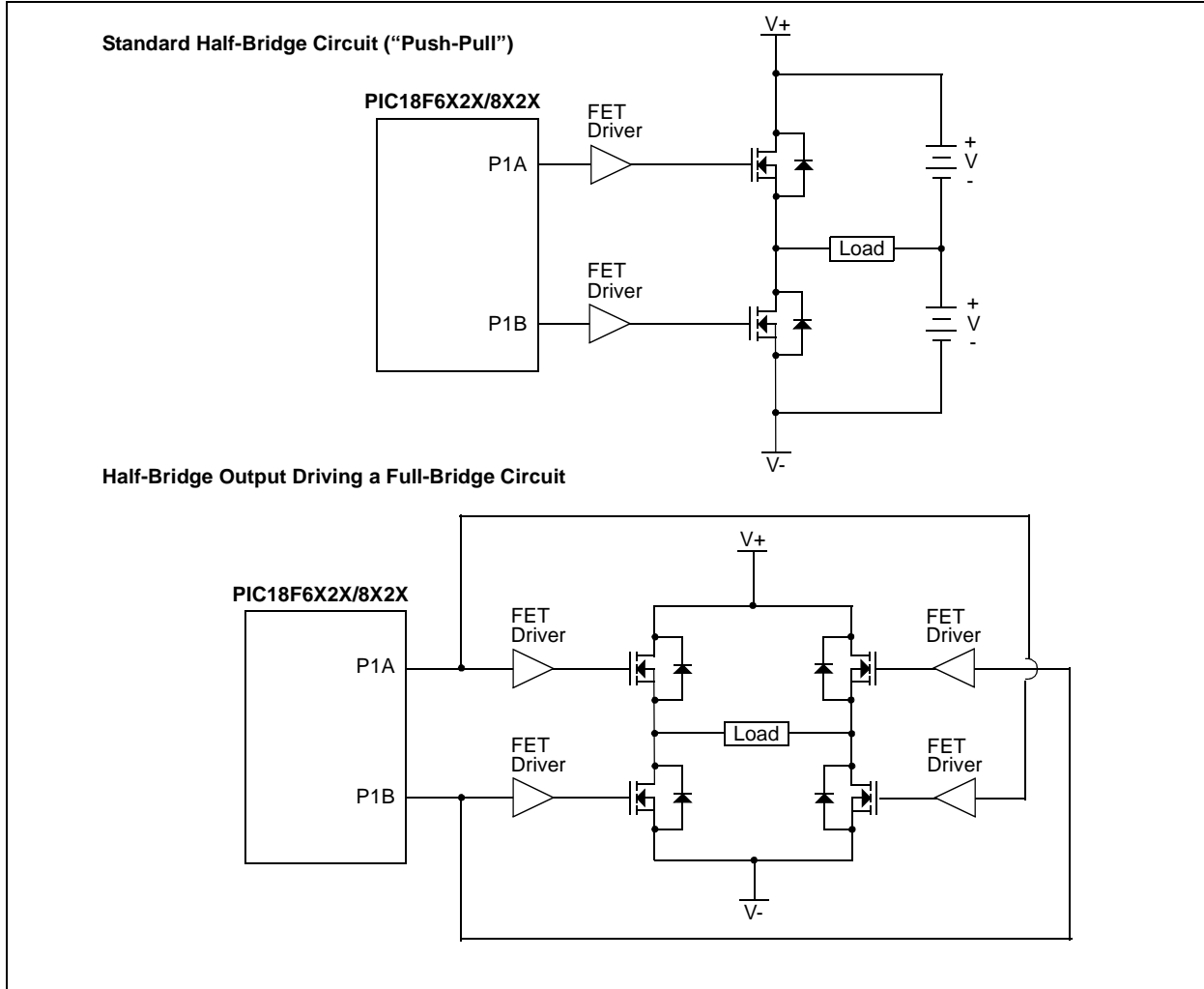

PIC18F6525/6621/8525/8621

17.4.5 FULL-BRIDGE MODE

In Full-Bridge Output mode, four pins are used as outputs; however, only two outputs are active at a time. In the Forward mode, pin P1A is continuously active and pin P1D is modulated. In the Reverse mode, pin P1C is continuously active and pin P1B is modulated. These are illustrated in Figure 17-6.

P1A, P1B, P1C and P1D outputs are multiplexed with the PORTC<2>, PORTE<6:5> and PORTG<4> data latches. The TRISC<2>, TRISC<6:5> and TRISG<4> bits must be cleared to make the P1A, P1B, P1C and P1D pins outputs.

FIGURE 17-6: FULL-BRIDGE PWM OUTPUT

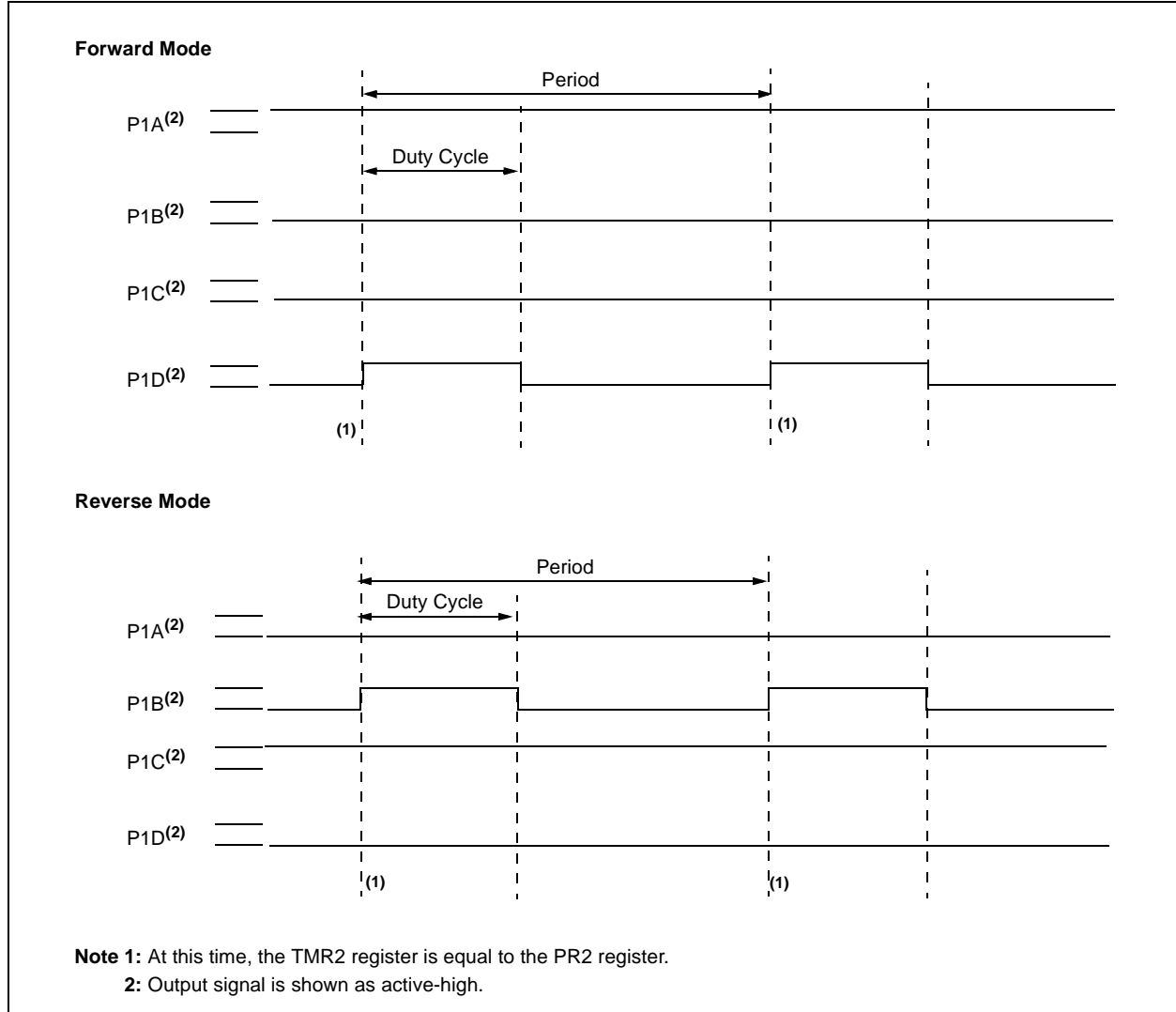

PIC18F6525/6621/8525/8621

FIGURE 17-7: EXAMPLE OF FULL-BRIDGE APPLICATION

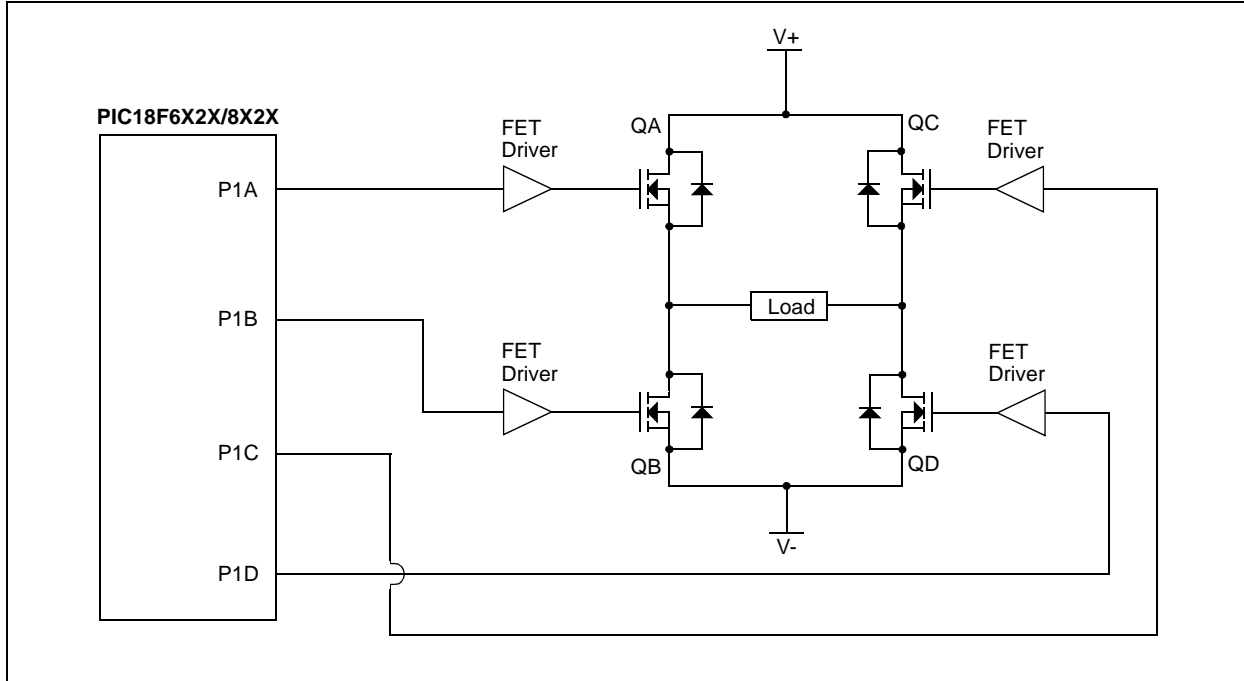

17.4.5.1 Direction Change in Full-Bridge Mode

In the Full-Bridge Output mode, the P1M1 bit in the CCP1CON register allows users to control the forward/reverse direction. When the application firmware changes this direction control bit, the module will assume the new direction on the next PWM cycle.

Just before the end of the current PWM period, the modulated outputs (P1B and P1D) are placed in their inactive state, while the unmodulated outputs (P1A and P1C) are switched to drive in the opposite direction. This occurs in a time interval of $(4 T_{osc} * (\text{Timer2 Prescale Value}))$ before the next PWM period begins. The Timer2 prescaler will be either 1, 4 or 16, depending on the value of the T2CKPS bit (T2CON<1:0>). During the interval from the switch of the unmodulated outputs to the beginning of the next period, the modulated outputs (P1B and P1D) remain inactive. This relationship is shown in Figure 17-8.

Note that in the Full-Bridge Output mode, the ECCP1 module does not provide any dead-band delay. In general, since only one output is modulated at all times, dead-band delay is not required. However, there is a situation where a dead-band delay might be required. This situation occurs when both of the following conditions are true:

1. The direction of the PWM output changes when the duty cycle of the output is at or near 100%.
2. The turn-off time of the power switch, including the power device and driver circuit, is greater than the turn-on time.

Figure 17-9 shows an example where the PWM direction changes from forward to reverse at a near 100% duty cycle. At time t_1 , the output P1A and P1D become inactive, while output P1C becomes active. In this example, since the turn-off time of the power devices is longer than the turn-on time, a shoot-through current may flow through power devices QC and QD (see Figure 17-7) for the duration of 't'. The same phenomenon will occur to power devices QA and QB for PWM direction change from reverse to forward.

If changing PWM direction at high duty cycle is required for an application, one of the following requirements must be met:

1. Reduce PWM for a PWM period before changing directions.
2. Use switch drivers that can drive the switches off faster than they can drive them on.

Other options to prevent shoot-through current may exist.

FIGURE 17-8: PWM DIRECTION CHANGE

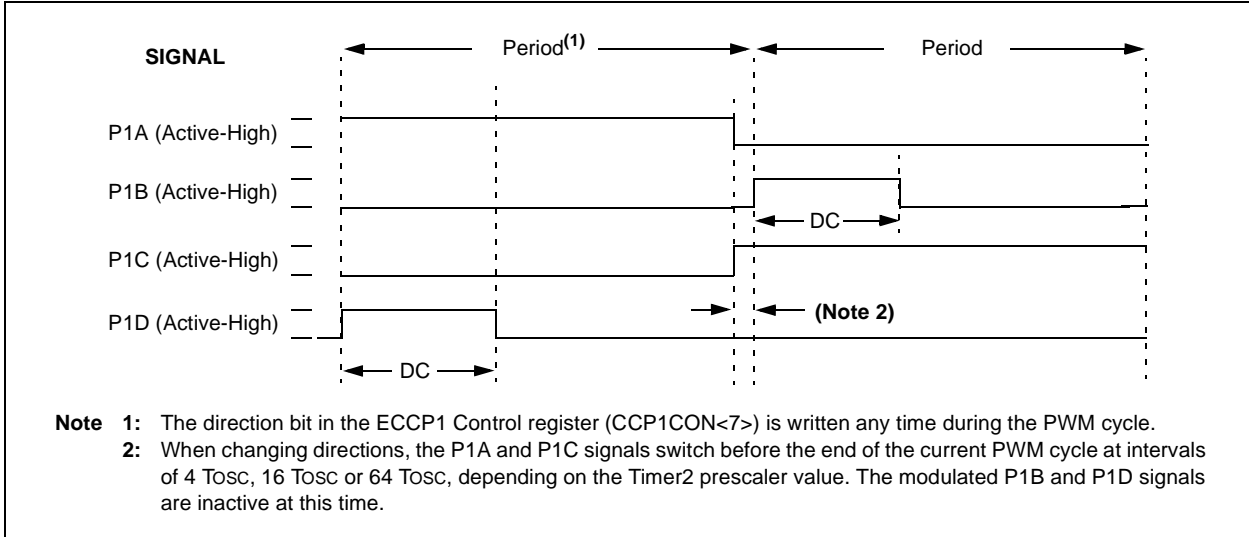
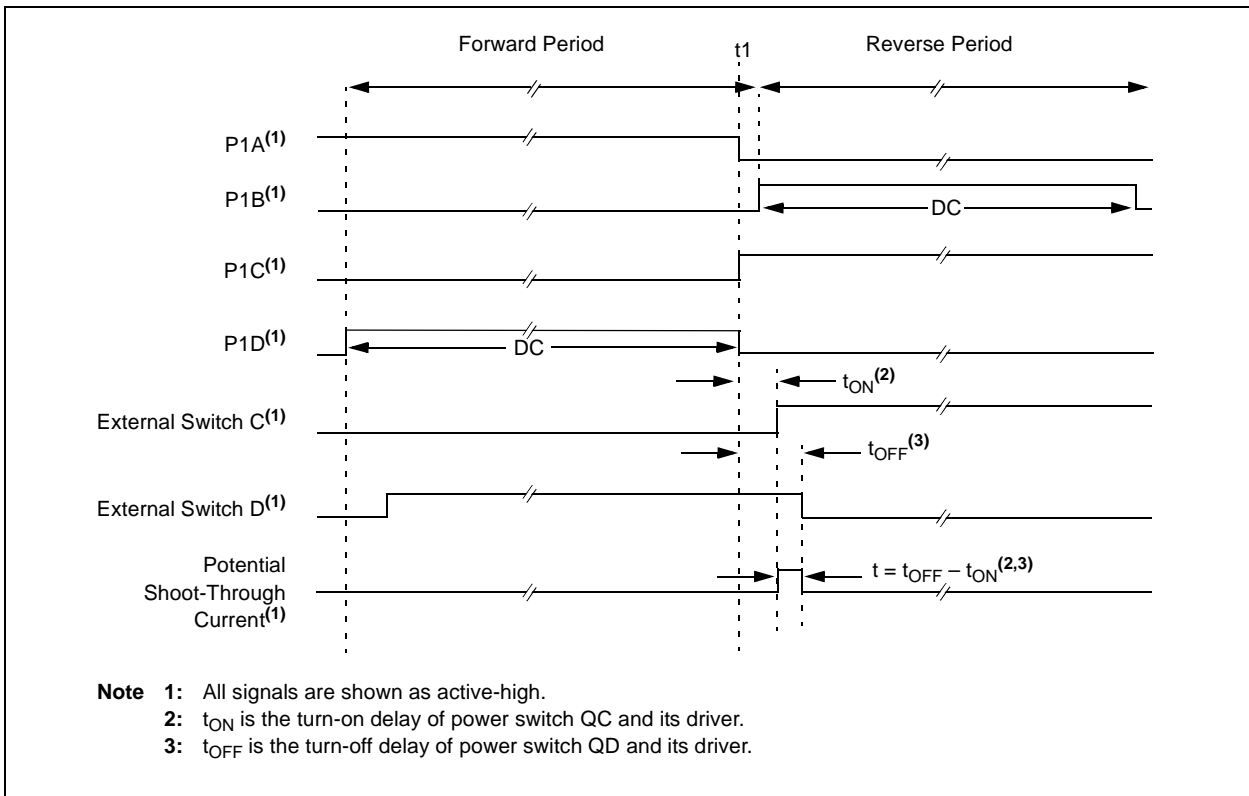

FIGURE 17-9: PWM DIRECTION CHANGE AT NEAR 100% DUTY CYCLE



PIC18F6525/6621/8525/8621

17.4.6 PROGRAMMABLE DEAD-BAND DELAY

In half-bridge applications where all power switches are modulated at the PWM frequency at all times, the power switches normally require more time to turn off than to turn on. If both the upper and lower power switches are switched at the same time (one turned on and the other turned off), both switches may be on for a short period of time until one switch completely turns off. During this brief interval, a very high current (*shoot-through current*) may flow through both power switches, shorting the bridge supply. To avoid this potentially destructive shoot-through current from flowing during switching, turning on either of the power switches is normally delayed to allow the other switch to completely turn off.

In the Half-Bridge Output mode, a digitally programmable dead-band delay is available to avoid shoot-through current from destroying the bridge power switches. The delay occurs at the signal transition from the non-active state to the active state. See Figure 17-4 for illustration. The lower seven bits of the ECCPxDEL register (Register 17-2) set the delay period in terms of microcontroller instruction cycles (T_{cy} or $4 T_{osc}$).

17.4.7 ENHANCED PWM AUTO-SHUTDOWN

When an ECCP module is programmed for any PWM mode, the active output pin(s) may be configured for auto-shutdown. Auto-shutdown immediately places the PWM output pin(s) into a defined shutdown state when a shutdown event occurs.

A shutdown event can be caused by either of the two comparator modules or the INT0/FLT0 pin (or any combination of these three sources). The comparators may be used to monitor a voltage input proportional to a current being monitored in the bridge circuit. If the voltage exceeds a threshold, the comparator switches state and triggers a shutdown. Alternatively, a digital signal on the INT0/FLT0 pin can also trigger a shutdown. The auto-shutdown feature can be disabled by not selecting any auto-shutdown sources. The auto-shutdown sources to be used are selected using the ECCP1AS2:ECCP1AS0 bits (bits<6:4> of the ECCP1AS register).

When a shutdown occurs, the output pin(s) are asynchronously placed in their shutdown states, specified by the PSS1AC1:PSS1AC0 and PSS1BD1:PSS1BD0 bits (ECCP1AS3:ECCP1AS0). Each pin pair (P1A/P1C and P1B/P1D) may be set to drive high, drive low or be tri-stated (not driving). The ECCP1ASE bit (ECCP1AS<7>) is also set to hold the Enhanced PWM outputs in their shutdown states.

The ECCP1ASE bit is set by hardware when a shutdown event occurs. If automatic restarts are not enabled, the ECCPASE bit is cleared by firmware when the cause of the shutdown clears. If automatic restarts are enabled, the ECCPASE bit is automatically cleared when the cause of the Auto-Shutdown has cleared.

If the ECCPASE bit is set when a PWM period begins, the PWM outputs remain in their shutdown state for that entire PWM period. When the ECCPASE bit is cleared, the PWM outputs will return to normal operation at the beginning of the next PWM period.

Note: Writing to the ECCPASE bit is disabled while a shutdown condition is active.

REGISTER 17-2: ECCPxDEL: PWM CONFIGURATION REGISTER

R/W-0	R/W-0	R/W-0	R/W-0	R/W-0	R/W-0	R/W-0	R/W-0	
PxRSEN	PxDC6	PxDC5	PxDC4	PxDC3	PxDC2	PxDC1	PxDC0	
bit 7								bit 0

- bit 7 **PxRSEN:** PWM Restart Enable bit
 1 = Upon Auto-Shutdown, the ECCPxASE bit clears automatically once the shutdown event goes away; the PWM restarts automatically
 0 = Upon Auto-Shutdown, ECCPxASE must be cleared in software to restart the PWM
- bit 6-0 **PxDC6:PxDC0:** PWM Delay Count bits
 Delay time, in number of $F_{osc}/4$ ($4 * T_{osc}$) cycles, between the scheduled and actual time for a PWM signal to transition to active.

Legend:

R = Readable bit	W = Writable bit	U = Unimplemented bit, read as '0'
-n = Value at POR	'1' = Bit is set	'0' = Bit is cleared x = Bit is unknown

PIC18F6525/6621/8525/8621

REGISTER 17-3: ECCPxAS: ENHANCED CAPTURE/COMPARE/PWM AUTO-SHUTDOWN CONTROL REGISTER

R/W-0	R/W-0	R/W-0	R/W-0	R/W-0	R/W-0	R/W-0	R/W-0
ECCPxASE	ECCPxAS2	ECCPxAS1	ECCPxAS0	PSSxAC1	PSSxAC0	PSSxBD1	PSSxBD0
bit 7							bit 0

- bit 7 **ECCPxASE:** ECCP Auto-Shutdown Event Status bit
 0 = ECCP outputs are operating
 1 = A shutdown event has occurred; ECCP outputs are in shutdown state
- bit 6-4 **ECCPxAS2:ECCPxAS0:** ECCP Auto-Shutdown Source Select bits
 000 = Auto-shutdown is disabled
 001 = Comparator 1 output
 010 = Comparator 2 output
 011 = Either Comparator 1 or 2
 100 = INTO/FLT0
 101 = INTO/FLT0 or Comparator 1
 110 = INTO/FLT0 or Comparator 2
 111 = INTO/FLT0 or Comparator 1 or Comparator 2
- bit 3-2 **PSSxAC1:PSSxAC0:** Pins A and C Shutdown State Control bits
 00 = Drive Pins A and C to '0'
 01 = Drive Pins A and C to '1'
 1x = Pins A and C tri-state
- bit 1-0 **PSSxBD1:PSSxBD0:** Pins B and D Shutdown State Control bits
 00 = Drive Pins B and D to '0'
 01 = Drive Pins B and D to '1'
 1x = Pins B and D tri-state

Legend:

R = Readable bit	W = Writable bit	U = Unimplemented bit, read as '0'
-n = Value at POR	'1' = Bit is set	'0' = Bit is cleared x = Bit is unknown

PIC18F6525/6621/8525/8621

17.4.7.1 Auto-Shutdown and Automatic Restart

The auto-shutdown feature can be configured to allow automatic restarts of the module following a shutdown event. This is enabled by setting the P1RSEN bit of the ECCP1DEL register (ECCP1DEL<7>).

In Shutdown mode with PRSEN = 1 (Figure 17-10), the ECCPASE bit will remain set for as long as the cause of the shutdown continues. When the shutdown condition clears, the ECCPASE bit is cleared. If PRSEN = 0 (Figure 17-11), once a shutdown condition occurs, the ECCPASE bit will remain set until it is cleared by firmware. Once ECCPASE is cleared, the Enhanced PWM will resume at the beginning of the next PWM period.

Note: Writing to the ECCPASE bit is disabled while a shutdown condition is active.

Independent of the P1RSEN bit setting, if the auto-shutdown source is one of the comparators, the shutdown condition is a level. The ECCPASE bit cannot be cleared as long as the cause of the shutdown persists.

The Auto-Shutdown mode can be forced by writing a '1' to the ECCPASE bit.

17.4.8 START-UP CONSIDERATIONS

When the ECCP module is used in the PWM mode, the application hardware must use the proper external pull-up and/or pull-down resistors on the PWM output pins. When the microcontroller is released from Reset, all of the I/O pins are in the high-impedance state. The external circuits must keep the power switch devices in the off state until the microcontroller drives the I/O pins with the proper signal levels, or activates the PWM output(s).

The CCP1M1:CCP1M0 bits (CCP1CON<1:0>) allow the user to choose whether the PWM output signals are active-high or active-low for each pair of PWM output pins (P1A/P1C and P1B/P1D). The PWM output polarities must be selected before the PWM pins are configured as outputs. Changing the polarity configuration while the PWM pins are configured as outputs is not recommended since it may result in damage to the application circuits.

The P1A, P1B, P1C and P1D output latches may not be in the proper states when the PWM module is initialized. Enabling the PWM pins for output at the same time as the ECCP module may cause damage to the application circuit. The ECCP module must be enabled in the proper output mode and complete a full PWM cycle before configuring the PWM pins as outputs. The completion of a full PWM cycle is indicated by the TMR2IF bit being set as the second PWM period begins.

FIGURE 17-10: PWM AUTO-SHUTDOWN (PRSEN = 1, AUTO-RESTART ENABLED)

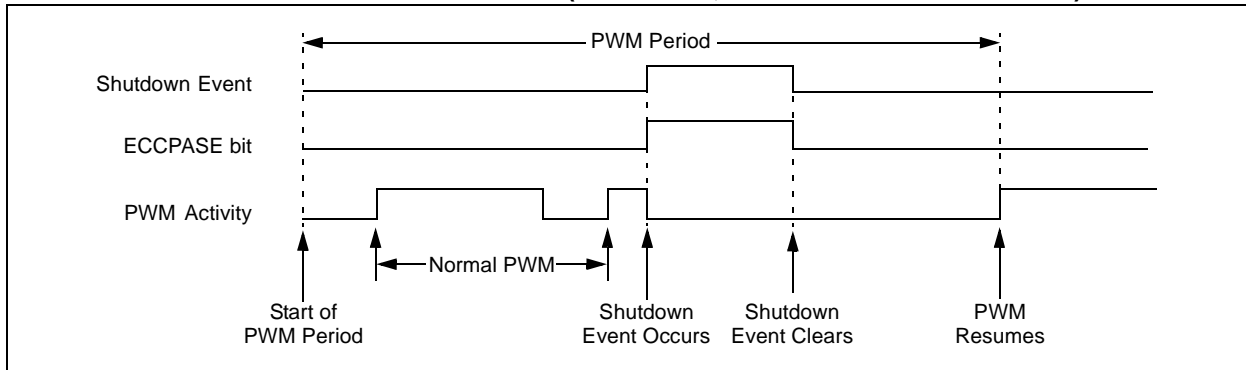
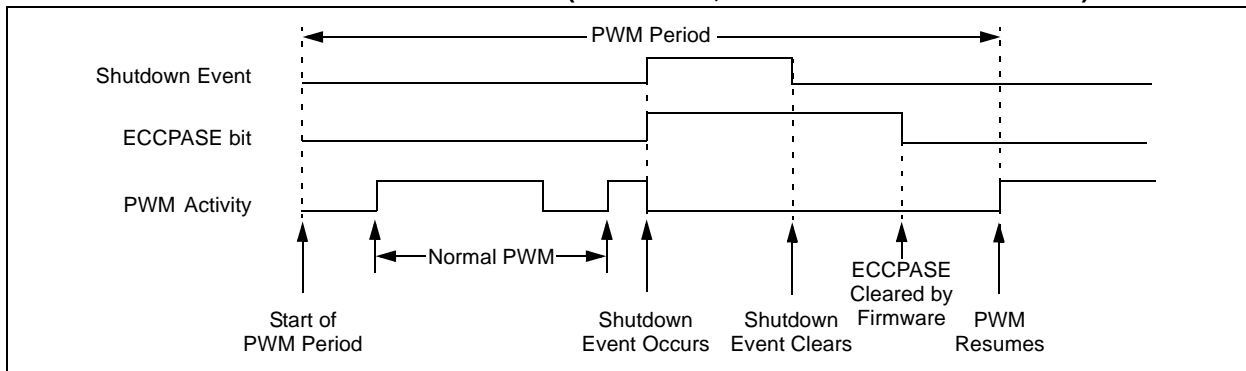

FIGURE 17-11: PWM AUTO-SHUTDOWN (PRSEN = 0, AUTO-RESTART DISABLED)



17.4.9 SETUP FOR PWM OPERATION

The following steps should be taken when configuring the ECCP1 module for PWM operation using Timer2:

1. Configure the PWM pins, P1A and P1B (and P1C and P1D, if used), as inputs by setting the corresponding TRIS bits.
2. Set the PWM period by loading the PR2 register.
3. If auto-shutdown is required do the following:
 - Disable auto-shutdown (ECCP1AS = 0)
 - Configure source (FLT0, Comparator 1 or Comparator 2)
 - Wait for non-shutdown condition
4. Configure the ECCP1 module for the desired PWM mode and configuration by loading the CCP1CON register with the appropriate values:
 - Select one of the available output configurations and direction with the P1M1:P1M0 bits.
 - Select the polarities of the PWM output signals with the CCP1M3:CCP1M0 bits.
5. Set the PWM duty cycle by loading the CCPR1L register and CCP1CON<5:4> bits.
6. For Half-Bridge Output mode, set the dead-band delay by loading ECCP1DEL<6:0> with the appropriate value.
7. If auto-shutdown operation is required, load the ECCP1AS register:
 - Select the auto-shutdown sources using the ECCP1AS2:ECCP1AS0 bits.
 - Select the shutdown states of the PWM output pins using the PSS1AC1:PSS1AC0 and PSS1BD1:PSS1BD0 bits.
 - Set the ECCP1ASE bit (ECCP1AS<7>).
 - Configure the comparators using the CMCON register.
 - Configure the comparator inputs as analog inputs.
8. If auto-restart operation is required, set the P1RSEN bit (ECCP1DEL<7>).
9. Configure and start TMR2:
 - Clear the TMR2 interrupt flag bit by clearing the TMR2IF bit (PIR1<1>).
 - Set the TMR2 prescale value by loading the T2CKPS bits (T2CON<1:0>).
 - Enable Timer2 by setting the TMR2ON bit (T2CON<2>).
10. Enable PWM outputs after a new PWM cycle has started:
 - Wait until TMRn overflows (TMRnIF bit is set).
 - Enable the ECCP1/P1A, P1B, P1C and/or P1D pin outputs by clearing the respective TRIS bits.
 - Clear the ECCP1ASE bit (ECCP1AS<7>).

17.4.10 EFFECTS OF A RESET

Both Power-on Reset and subsequent Resets will force all ports to Input mode and the CCP registers to their Reset states.

This forces the Enhanced CCP module to reset to a state compatible with the standard CCP module.

PIC18F6525/6621/8525/8621

TABLE 17-5: REGISTERS ASSOCIATED WITH ECCP MODULES AND TIMER1 TO TIMER4

Name	Bit 7	Bit 6	Bit 5	Bit 4	Bit 3	Bit 2	Bit 1	Bit 0	Value on POR, BOR	Value on all other Resets	
INTCON	GIE/GIEH	PEIE/GIEL	TMR0IE	INT0IE	RBIE	TMR0IF	INT0IF	RBIF	0000 000x	0000 000u	
RCON	IPEN	—	—	\overline{RI}	\overline{TO}	\overline{PD}	\overline{POR}	\overline{BOR}	0--1 11qq	0--q qquu	
PIR1	PSPIF ⁽¹⁾	ADIF	RC1IF	TX1IF	SSPIF	CCP1IF	TMR2IF	TMR1IF	0000 0000	0000 0000	
PIE1	PSPIE ⁽¹⁾	ADIE	RC1IE	TX1IE	SSPIE	CCP1IE	TMR2IE	TMR1IE	0000 0000	0000 0000	
IPR1	PSPIP ⁽¹⁾	ADIP	RC1IP	TX1IP	SSPIP	CCP1IP	TMR2IP	TMR1IP	1111 1111	1111 1111	
PIR2	—	CMIF	—	EEIF	BCLIF	LVDIF	TMR3IF	CCP2IF	-0-0 0000	---0 0000	
PIE2	—	CMIE	—	EEIE	BCLIE	LVDIE	TMR3IE	CCP2IE	-0-0 0000	---0 0000	
IPR2	—	CMIP	—	EEIP	BCLIP	LVDIP	TMR3IP	CCP2IP	-1-1 1111	---1 1111	
PIR3	—	—	RC2IF	TX2IF	TMR4IF	CCP5IF	CCP4IF	CCP3IF	--00 0000	--00 0000	
PIE3	—	—	RC2IE	TX2IE	TMR4IE	CCP5IE	CCP4IE	CCP3IE	--00 0000	--00 0000	
IPR3	—	—	RC2IP	TX2IP	TMR4IP	CCP5IP	CCP4IP	CCP3IP	--11 1111	--11 1111	
TRISB	PORTB Data Direction Register								1111 1111	1111 1111	
TRISC	PORTC Data Direction Register								1111 1111	1111 1111	
TRISCD	PORTD Data Direction Register								1111 1111	1111 1111	
TRISE	PORTE Data Direction Register								1111 1111	1111 1111	
TRISF	PORTF Data Direction Register								1111 1111	1111 1111	
TRISG	—	—	—	PORTG Data Direction Register				---	1111	---	1111
TRISH	PORTH Data Direction Register								1111 1111	1111 1111	
TMR1L	Timer1 Register Low Byte								xxxx xxxx	uuuu uuuu	
TMR1H	Timer1 Register High Byte								xxxx xxxx	uuuu uuuu	
T1CON	RD16	—	T1CKPS1	T1CKPS0	T1OSCEN	$\overline{T1SYNC}$	TMR1CS	TMR1ON	0-00 0000	u-uu uuuu	
TMR2	Timer2 Register								0000 0000	0000 0000	
T2CON	—	T2OUTPS3	T2OUTPS2	T2OUTPS1	T2OUTPS0	TMR2ON	T2CKPS1	T2CKPS0	-000 0000	-000 0000	
PR2	Timer2 Period Register								1111 1111	1111 1111	
TMR3L	Timer3 Register Low Byte								xxxx xxxx	uuuu uuuu	
TMR3H	Timer3 Register High Byte								xxxx xxxx	uuuu uuuu	
T3CON	RD16	T3CCP2	T3CKPS1	T3CKPS0	T3CCP1	$\overline{T3SYNC}$	TMR3CS	TMR3ON	0000 0000	uuuu uuuu	
TMR4	Timer4 Register								0000 0000	0000 0000	
T4CON	—	T4OUTPS3	T4OUTPS2	T4OUTPS1	T4OUTPS0	TMR4ON	T4CKPS1	T4CKPS0	-000 0000	-000 0000	
PR4	Timer4 Period Register								1111 1111	1111 1111	
CCPR1L	Enhanced Capture/Compare/PWM Register 1 Low Byte								xxxx xxxx	uuuu uuuu	
CCPR1H	Enhanced Capture/Compare/PWM Register 1 High Byte								xxxx xxxx	uuuu uuuu	
CCP1CON	P1M1	P1M0	DC1B1	DC1B0	CCP1M3	CCP1M2	CCP1M1	CCP1M0	0000 0000	0000 0000	
ECCP1AS	ECCP1ASE	ECCP1AS2	ECCP1AS1	ECCP1AS0	PSS1AC1	PSS1AC0	PSS1BD1	PSS1BD0	0000 0000	0000 0000	
ECCP1DEL	P1RSEN	P1DC6	P1DC5	P1DC4	P1DC3	P1DC2	P1DC1	P1DC0	0000 0000	uuuu uuuu	
CCPR2L	Enhanced Capture/Compare/PWM Register 2 Low Byte								xxxx xxxx	uuuu uuuu	
CCPR2H	Enhanced Capture/Compare/PWM Register 2 High Byte								xxxx xxxx	uuuu uuuu	
CCP2CON	P2M1	P2M0	DC2B1	DC2B0	CCP2M3	CCP2M2	CCP2M1	CCP2M0	0000 0000	0000 0000	
ECCP2AS	ECCP2ASE	ECCP2AS2	ECCP2AS1	ECCP2AS0	PSS2AC1	PSS2AC0	PSS2BD1	PSS2BD0	0000 0000	0000 0000	
ECCP2DEL	P2RSEN	P2DC6	P2DC5	P2DC4	P2DC3	P2DC2	P2DC1	P2DC0	0000 0000	uuuu uuuu	
CCPR3L	Enhanced Capture/Compare/PWM Register 3 Low Byte								xxxx xxxx	uuuu uuuu	
CCPR3H	Enhanced Capture/Compare/PWM Register 3 High Byte								xxxx xxxx	uuuu uuuu	
CCP3CON	P3M1	P3M0	DC3B1	DC3B0	CCP3M3	CCP3M2	CCP3M1	CCP3M0	0000 0000	0000 0000	
ECCP3AS	ECCP3ASE	ECCP3AS2	ECCP3AS1	ECCP3AS0	PSS3AC1	PSS3AC0	PSS3BD1	PSS3BD0	0000 0000	0000 0000	
ECCP3DEL	Px3RSEN	P3DC6	P3DC5	P3DC4	P3DC3	P3DC2	P3DC1	P3DC0	0000 0000	uuuu uuuu	

Legend: x = unknown, u = unchanged, — = unimplemented, read as '0'. Shaded cells are not used during ECCP operation.

Note 1: Enabled only in Microcontroller mode for PIC18F8525/8621 devices.

18.0 MASTER SYNCHRONOUS SERIAL PORT (MSSP) MODULE

18.1 Master SSP (MSSP) Module Overview

The Master Synchronous Serial Port (MSSP) module is a serial interface, useful for communicating with other peripheral or microcontroller devices. These peripheral devices may be serial EEPROMs, shift registers, display drivers, A/D converters, etc. The MSSP module can operate in one of two modes:

- Serial Peripheral Interface (SPI)
- Inter-Integrated Circuit (I²C)
 - Full Master mode
 - Slave mode (with general address call)

The I²C interface supports the following modes in hardware:

- Master mode
- Multi-Master mode
- Slave mode

18.2 Control Registers

The MSSP module has three associated registers. These include a status register (SSPSTAT) and two control registers (SSPCON1 and SSPCON2). The use of these registers and their individual configuration bits differ significantly depending on whether the MSSP module is operated in SPI or I²C mode.

Additional details are provided under the individual sections.

18.3 SPI Mode

The SPI mode allows 8 bits of data to be synchronously transmitted and received simultaneously. All four modes of SPI are supported. To accomplish communication, typically three pins are used:

- Serial Data Out (SDO) – RC5/SDO
- Serial Data In (SDI) – RC4/SDI/SDA
- Serial Clock (SCK) – RC3/SCK/SCL

Additionally, a fourth pin may be used when in a Slave mode of operation:

- Slave Select (\overline{SS}) – RF7/ \overline{SS}

Figure 18-1 shows the block diagram of the MSSP module when operating in SPI mode.

FIGURE 18-1: MSSP BLOCK DIAGRAM (SPI™ MODE)

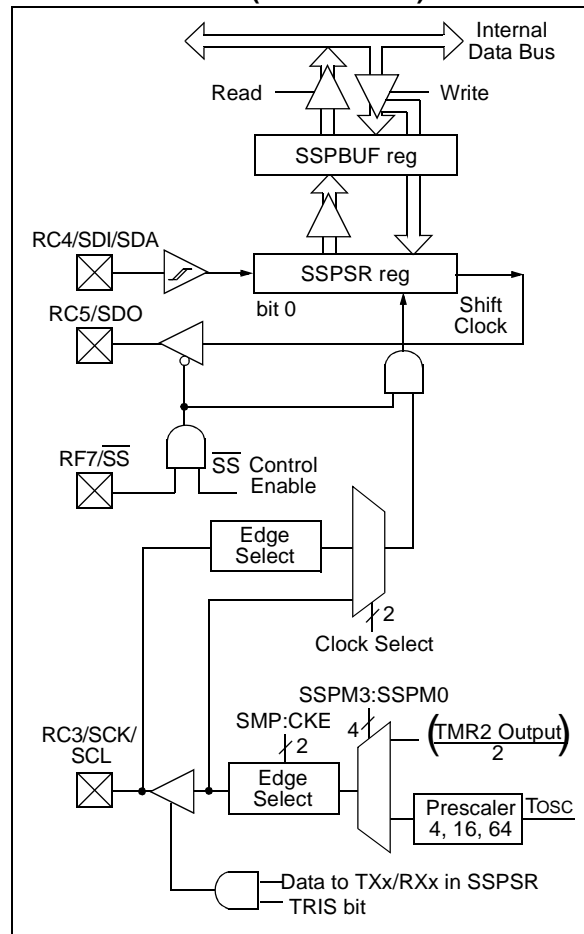

PIC18F6525/6621/8525/8621

18.3.1 REGISTERS

The MSSP module has four registers for SPI mode operation. These are:

- MSSP Control Register 1 (SSPCON1)
- MSSP Status Register (SSPSTAT)
- Serial Receive/Transmit Buffer Register (SSPBUF)
- MSSP Shift Register (SSPSR) – Not directly accessible

SSPCON1 and SSPSTAT are the control and status registers in SPI mode operation. The SSPCON1 register is readable and writable. The lower 6 bits of the SSPSTAT are read-only. The upper two bits of the SSPSTAT are read/write.

SSPSR is the shift register used for shifting data in or out. SSPBUF is the buffer register to which data bytes are written to or read from.

In receive operations, SSPSR and SSPBUF together create a double-buffered receiver. When SSPSR receives a complete byte, it is transferred to SSPBUF and the SSPIF interrupt is set.

During transmission, the SSPBUF is not double-buffered. A write to SSPBUF will write to both SSPBUF and SSPSR.

REGISTER 18-1: SSPSTAT: MSSP STATUS REGISTER (SPI MODE)

R/W-0	R/W-0	R-0	R-0	R-0	R-0	R-0	R-0
SMP	CKE	D/ \bar{A}	P	S	$\overline{R/W}$	UA	BF
						bit 0	
bit 7							

- bit 7 **SMP:** Sample bit
SPI Master mode:
 1 = Input data sampled at end of data output time
 0 = Input data sampled at middle of data output time
SPI Slave mode:
 SMP must be cleared when SPI is used in Slave mode.
- bit 6 **CKE:** SPI Clock Edge Select bit
 1 = Transmit occurs on transition from active to Idle clock state
 0 = Transmit occurs on transition from Idle to active clock state
Note: Polarity of clock state is set by the CKP bit (SSPCON1<4>).
- bit 5 **$\overline{D/A}$:** Data/Address bit
 Used in I²C mode only.
- bit 4 **P:** Stop bit
 Used in I²C mode only. This bit is cleared when the MSSP module is disabled, SSPEN is cleared.
- bit 3 **S:** Start bit
 Used in I²C mode only.
- bit 2 **$\overline{R/W}$:** Read/Write bit Information
 Used in I²C mode only.
- bit 1 **UA:** Update Address bit
 Used in I²C mode only.
- bit 0 **BF:** Buffer Full Status bit
 1 = Receive complete, SSPBUF is full
 0 = Receive not complete, SSPBUF is empty

Legend:

R = Readable bit	W = Writable bit	U = Unimplemented bit, read as '0'
-n = Value at POR	'1' = Bit is set	'0' = Bit is cleared x = Bit is unknown

PIC18F6525/6621/8525/8621

REGISTER 18-2: SSPCON1: MSSP CONTROL REGISTER 1 (SPI MODE)

R/W-0	R/W-0	R/W-0	R/W-0	R/W-0	R/W-0	R/W-0	R/W-0
WCOL	SSPOV	SSPEN	CKP	SSPM3	SSPM2	SSPM1	SSPM0

bit 7

bit 0

bit 7 **WCOL:** Write Collision Detect bit (Transmit mode only)

- 1 = The SSPBUF register is written while it is still transmitting the previous word (must be cleared in software)
- 0 = No collision

bit 6 **SSPOV:** Receive Overflow Indicator bit

SPI Slave mode:

- 1 = A new byte is received while the SSPBUF register is still holding the previous data. In case of overflow, the data in SSPSR is lost. Overflow can only occur in Slave mode. The user must read the SSPBUF, even if only transmitting data, to avoid setting overflow (must be cleared in software).
- 0 = No overflow

Note: In Master mode, the overflow bit is not set since each new reception (and transmission) is initiated by writing to the SSPBUF register.

bit 5 **SSPEN:** Master Synchronous Serial Port Enable bit

- 1 = Enables serial port and configures SCK, SDO, SDI and \overline{SS} as serial port pins
- 0 = Disables serial port and configures these pins as I/O port pins

Note: When enabled, these pins must be properly configured as input or output.

bit 4 **CKP:** Clock Polarity Select bit

- 1 = Idle state for clock is a high level
- 0 = Idle state for clock is a low level

bit 3-0 **SSPM3:SSPM0:** Master Synchronous Serial Port Mode Select bits

- 0101 = SPI Slave mode, clock = SCK pin, \overline{SS} pin control disabled, \overline{SS} can be used as I/O pin
- 0100 = SPI Slave mode, clock = SCK pin, \overline{SS} pin control enabled
- 0011 = SPI Master mode, clock = TMR2 output/2
- 0010 = SPI Master mode, clock = Fosc/64
- 0001 = SPI Master mode, clock = Fosc/16
- 0000 = SPI Master mode, clock = Fosc/4

Note: Bit combinations not specifically listed here are either reserved or implemented in I²C mode only.

Legend:

R = Readable bit	W = Writable bit	U = Unimplemented bit, read as '0'
-n = Value at POR	'1' = Bit is set	'0' = Bit is cleared x = Bit is unknown

PIC18F6525/6621/8525/8621

18.3.2 OPERATION

When initializing the SPI, several options need to be specified. This is done by programming the appropriate control bits (SSPCON1<5:0>) and SSPSTAT<7:6>. These control bits allow the following to be specified:

- Master mode (SCK is the clock output)
- Slave mode (SCK is the clock input)
- Clock Polarity (Idle state of SCK)
- Data Input Sample Phase (middle or end of data output time)
- Clock Edge (output data on rising/falling edge of SCK)
- Clock Rate (Master mode only)
- Slave Select mode (Slave mode only)

The MSSP consists of a transmit/receive shift register (SSPSR) and a buffer register (SSPBUF). The SSPSR shifts the data in and out of the device, MSb first. The SSPBUF holds the data that was written to the SSPSR until the received data is ready. Once the 8 bits of data have been received, that byte is moved to the SSPBUF register. Then the buffer full detect bit, BF (SSPSTAT<0>) and the interrupt flag bit, SSPIF, are set. This double-buffering of the received data (SSPBUF) allows the next byte to start reception before

reading the data that was just received. Any write to the SSPBUF register during transmission/reception of data will be ignored and the write collision detect bit, WCOL (SSPCON1<7>), will be set. User software must clear the WCOL bit so that it can be determined if the following write(s) to the SSPBUF register completed successfully.

When the application software is expecting to receive valid data, the SSPBUF should be read before the next byte of data to transfer is written to the SSPBUF. Buffer full bit, BF (SSPSTAT<0>), indicates when SSPBUF has been loaded with the received data (transmission is complete). When the SSPBUF is read, the BF bit is cleared. This data may be irrelevant if the SPI is only a transmitter. Generally, the MSSP interrupt is used to determine when the transmission/reception has completed. The SSPBUF must be read and/or written. If the interrupt method is not going to be used, then software polling can be done to ensure that a write collision does not occur. Example 18-1 shows the loading of the SSPBUF (SSPSR) for data transmission.

The SSPSR is not directly readable or writable and can only be accessed by addressing the SSPBUF register. Additionally, the MSSP Status register (SSPSTAT) indicates the various status conditions.

EXAMPLE 18-1: LOADING THE SSPBUF (SSPSR) REGISTER

LOOP	BTFSS	SSPSTAT, BF	;Has data been received (transmit complete)?
	BRA	LOOP	;No
	MOVF	SSPBUF, W	;WREG reg = contents of SSPBUF
	MOVWF	RXDATA	;Save in user RAM, if data is meaningful
	MOVF	TXDATA, W	;W reg = contents of TXDATA
	MOVWF	SSPBUF	;New data to xmit

PIC18F6525/6621/8525/8621

18.3.3 ENABLING SPI I/O

To enable the serial port, MSSP Enable bit, SSPEN (SSPCON1<5>), must be set. To reset or reconfigure SPI mode, clear the SSPEN bit, re-initialize the SSPCON registers and then set the SSPEN bit. This configures the SDI, SDO, SCK and \overline{SS} pins as serial port pins. For the pins to behave as the serial port function, some must have their data direction bits (in the TRIS register) appropriately programmed as follows:

- SDI is automatically controlled by the SPI module
- SDO must have TRISC<5> bit cleared
- SCK (Master mode) must have TRISC<3> bit cleared
- SCK (Slave mode) must have TRISC<3> bit set
- \overline{SS} must have TRISF<7> bit set

Any serial port function that is not desired may be overridden by programming the corresponding data direction (TRIS) register to the opposite value.

18.3.4 TYPICAL CONNECTION

Figure 18-2 shows a typical connection between two microcontrollers. The master controller (Processor 1) initiates the data transfer by sending the SCK signal. Data is shifted out of both shift registers on their programmed clock edge and latched on the opposite edge of the clock. Both processors should be programmed to the same Clock Polarity (CKP), then both controllers would send and receive data at the same time. Whether the data is meaningful (or dummy data) depends on the application software. This leads to three scenarios for data transmission:

- Master sends data – Slave sends dummy data
- Master sends data – Slave sends data
- Master sends dummy data – Slave sends data

FIGURE 18-2: SPI™ MASTER/SLAVE CONNECTION

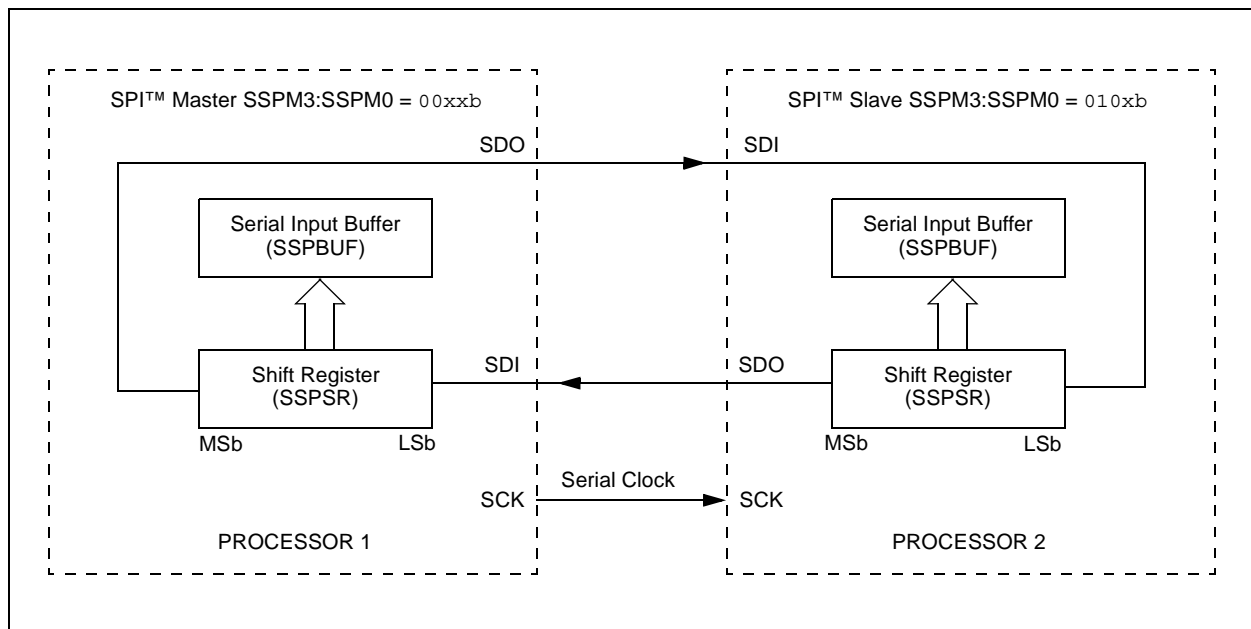

PIC18F6525/6621/8525/8621

18.3.5 MASTER MODE

The master can initiate the data transfer at any time because it controls the SCK. The master determines when the slave (Processor 2, Figure 18-2) is to broadcast data by the software protocol.

In Master mode, the data is transmitted/received as soon as the SSPBUF register is written to. If the SPI is only going to receive, the SDO output could be disabled (programmed as an input). The SSPSR register will continue to shift in the signal present on the SDI pin at the programmed clock rate. As each byte is received, it will be loaded into the SSPBUF register as if a normal received byte (interrupts and status bits appropriately set). This could be useful in receiver applications as a "Line Activity Monitor" mode.

The clock polarity is selected by appropriately programming the CKP bit (SSPCON1<4>). This then, would give waveforms for SPI communication as shown in Figure 18-3, Figure 18-5 and Figure 18-6, where the MSB is transmitted first. In Master mode, the SPI clock rate (bit rate) is user programmable to be one of the following:

- $F_{osc}/4$ (or T_{CY})
- $F_{osc}/16$ (or $4 \cdot T_{CY}$)
- $F_{osc}/64$ (or $16 \cdot T_{CY}$)
- $Timer2\ output/2$

This allows a maximum data rate (at 40 MHz) of 10.00 Mbps.

Figure 18-3 shows the waveforms for Master mode.

FIGURE 18-3: SPI™ MODE WAVEFORM (MASTER MODE)

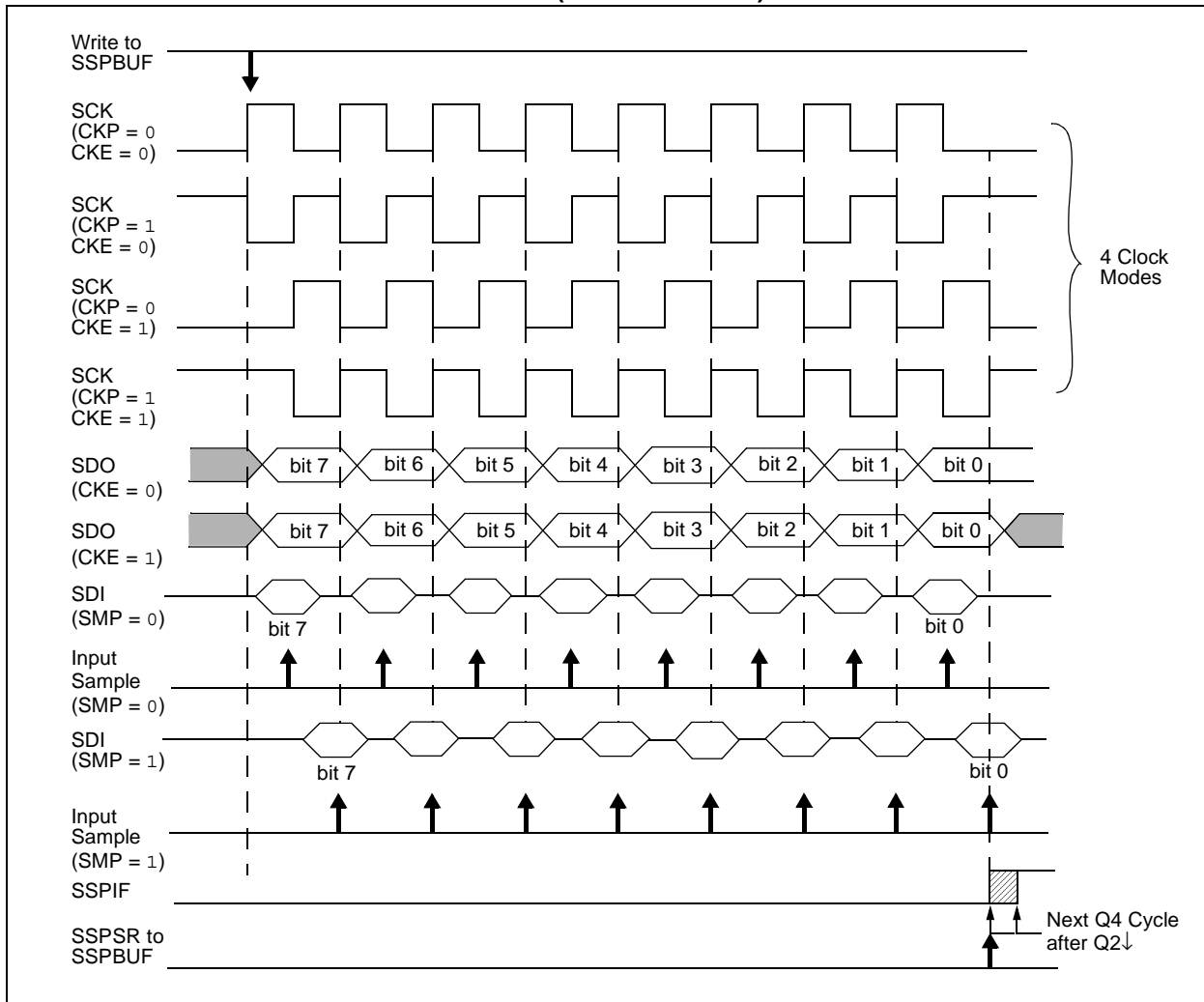

18.3.6 SLAVE MODE

In Slave mode, the data is transmitted and received as the external clock pulses appear on SCK. When the last bit is latched, the SSPIF interrupt flag bit is set.

While in Slave mode, the external clock is supplied by the external clock source on the SCK pin. This external clock must meet the minimum high and low times as specified in the electrical specifications.

Before enabling the module in SPI Slave mode, the clock line must match the proper Idle state. The clock line can be observed by reading the SCK pin. The Idle state is determined by the CKP bit (SSPCON1<4>).

While in Sleep mode, the slave can transmit/receive data. When a byte is received, the device will wake-up from Sleep.

18.3.7 SLAVE SELECT SYNCHRONIZATION

The \overline{SS} pin allows a Synchronous Slave mode. The SPI must be in Slave mode with \overline{SS} pin control enabled (SSPCON1<3:0> = 04h). The pin must not be driven low for the \overline{SS} pin to function as an input. The data latch

must be high. When the \overline{SS} pin is low, transmission and reception are enabled and the SDO pin is driven. When the \overline{SS} pin goes high, the SDO pin is no longer driven even if in the middle of a transmitted byte and becomes a floating output. External pull-up/pull-down resistors may be desirable depending on the application.

Note 1: When the SPI is in Slave mode with \overline{SS} pin control enabled (SSPCON<3:0> = 0100), the SPI module will reset if the \overline{SS} pin is set to VDD.

2: If the SPI is used in Slave mode with CKE set, then the \overline{SS} pin control must be enabled.

When the SPI module resets, the bit counter is forced to '0'. This can be done by either forcing the \overline{SS} pin to a high level or clearing the SSPEN bit.

To emulate two-wire communication, the SDO pin can be connected to the SDI pin. When the SPI needs to operate as a receiver, the SDO pin can be configured as an input. This disables transmissions from the SDO. The SDI can always be left as an input (SDI function) since it cannot create a bus conflict.

FIGURE 18-4: SLAVE SYNCHRONIZATION WAVEFORM

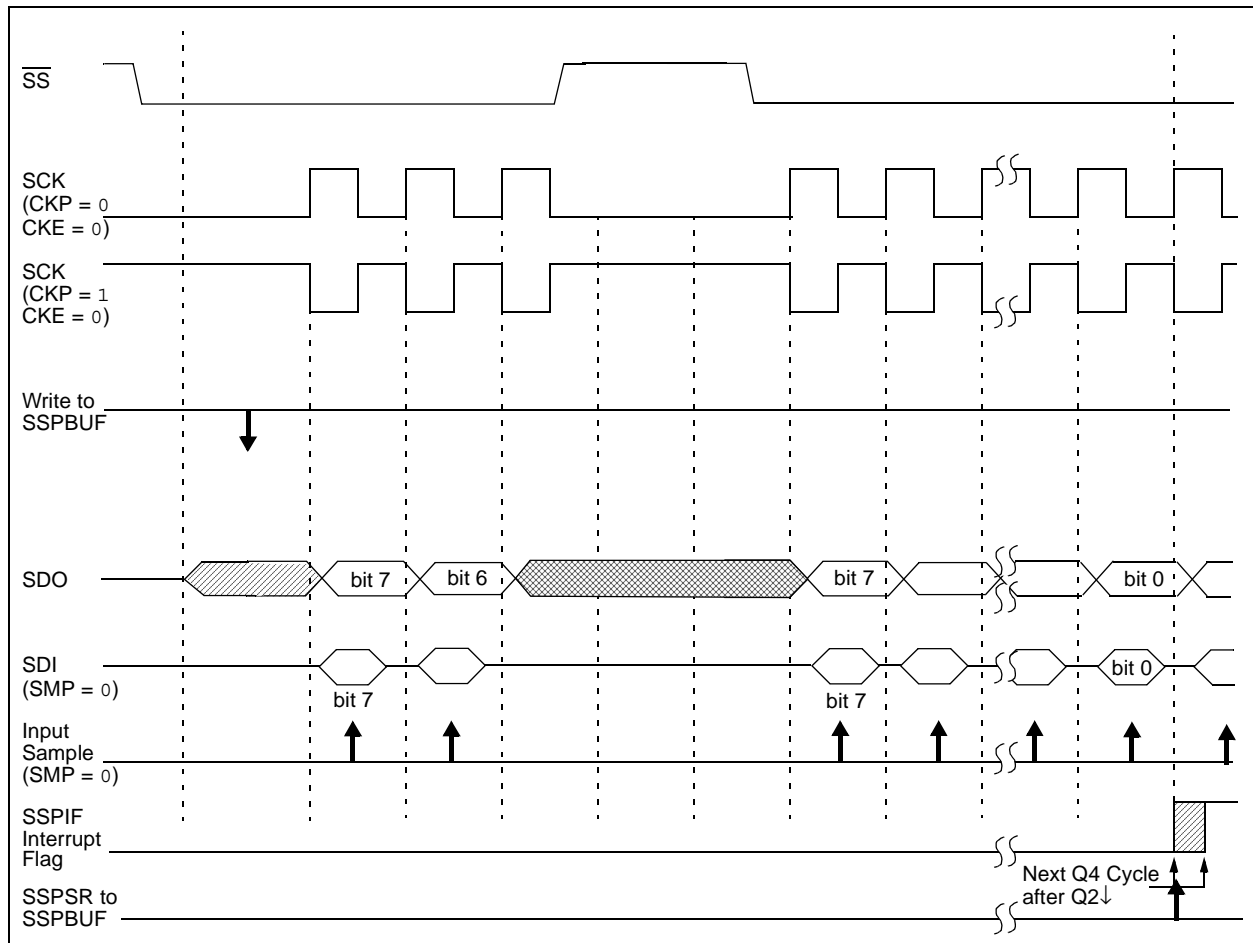

PIC18F6525/6621/8525/8621

FIGURE 18-5: SPI™ MODE WAVEFORM (SLAVE MODE WITH CKE = 0)

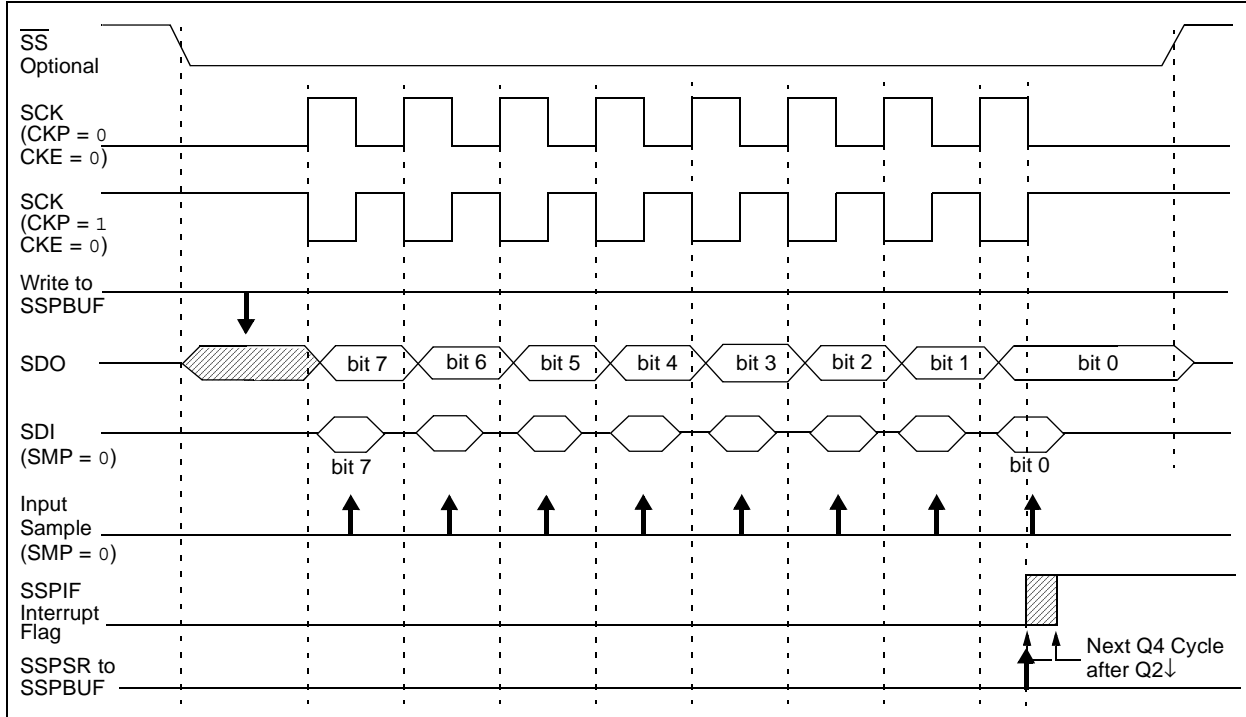
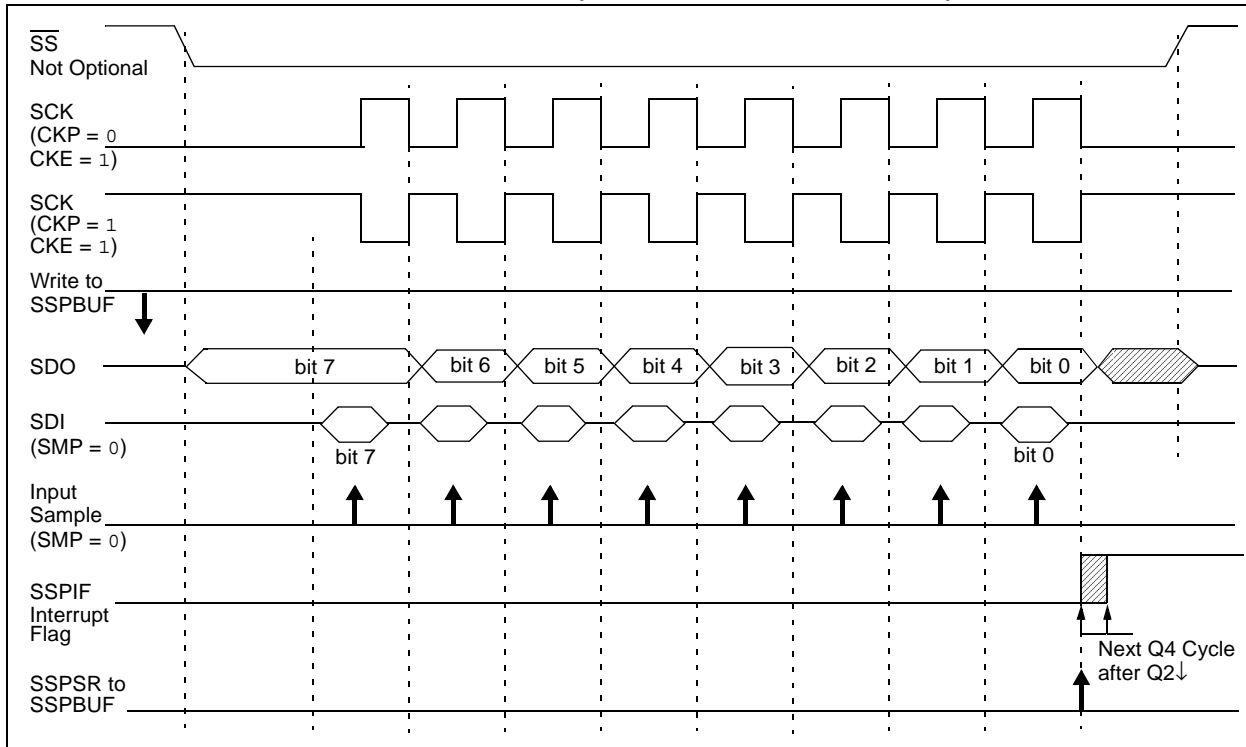

FIGURE 18-6: SPI™ MODE WAVEFORM (SLAVE MODE WITH CKE = 1)



PIC18F6525/6621/8525/8621

18.3.8 SLEEP OPERATION

In Master mode, all module clocks are halted and the transmission/reception will remain in that state until the device wakes from Sleep. After the device returns to normal mode, the module will continue to transmit/receive data.

In Slave mode, the SPI Transmit/Receive Shift register operates asynchronously to the device. This allows the device to be placed in Sleep mode and data to be shifted into the SPI Transmit/Receive Shift register. When all 8 bits have been received, the MSSP interrupt flag bit will be set and if enabled, will wake the device from Sleep.

18.3.9 EFFECTS OF A RESET

A Reset disables the MSSP module and terminates the current transfer.

18.3.10 BUS MODE COMPATIBILITY

Table 18-1 shows the compatibility between the standard SPI modes and the states of the CKP and CKE control bits.

TABLE 18-1: SPI™ BUS MODES

Standard SPI Mode Terminology	Control Bits State	
	CKP	CKE
0, 0	0	1
0, 1	0	0
1, 0	1	1
1, 1	1	0

There is also a SMP bit which controls when the data is sampled.

TABLE 18-2: REGISTERS ASSOCIATED WITH SPI™ OPERATION

Name	Bit 7	Bit 6	Bit 5	Bit 4	Bit 3	Bit 2	Bit 1	Bit 0	Value on POR, BOR	Value on all other Resets
INTCON	GIE/GIEH	PEIE/GIEL	TMR0IE	INT0IE	RBIE	TMR0IF	INT0IF	RBIF	0000 000x	0000 000u
PIR1	PSPIF ⁽¹⁾	ADIF	RC1IF	TX1IF	SSPIF	CCP1IF	TMR2IF	TMR1IF	0000 0000	0000 0000
PIE1	PSPIE ⁽¹⁾	ADIE	RC1IE	TX1IE	SSPIE	CCP1IE	TMR2IE	TMR1IE	0000 0000	0000 0000
IPR1	PSPIP ⁽¹⁾	ADIP	RC1IP	TX1IP	SSPIP	CCP1IP	TMR2IP	TMR1IP	1111 1111	1111 1111
TRISC	PORTC Data Direction Register								1111 1111	1111 1111
TRISF	TRISF7	TRISF6	TRISF5	TRISF4	TRISF3	TRISF2	TRISF1	TRISF0	1111 1111	1111 1111
SSPBUF	MSSP Receive Buffer/Transmit Register								xxxx xxxx	uuuu uuuu
SSPCON1	WCOL	SSPOV	SSPEN	CKP	SSPM3	SSPM2	SSPM1	SSPM0	0000 0000	0000 0000
SSPSTAT	SMP	CKE	D/Ā	P	S	R/W	UA	BF	0000 0000	0000 0000

Legend: x = unknown, u = unchanged, — = unimplemented, read as '0'. Shaded cells are not used by the MSSP in SPI™ mode.

Note 1: Enabled only in Microcontroller mode for PIC18F8525/8621 devices.

PIC18F6525/6621/8525/8621

18.4 I²C Mode

The MSSP module in I²C mode fully implements all master and slave functions (including general call support) and provides interrupts on Start and Stop bits in hardware to determine a free bus (multi-master function). The MSSP module implements the standard mode specifications, as well as 7-bit and 10-bit addressing.

Two pins are used for data transfer:

- Serial clock (SCL) – RC3/SCK/SCL
- Serial data (SDA) – RC4/SDI/SDA

The user must configure these pins as inputs or outputs through the TRISC<4:3> bits.

FIGURE 18-7: MSSP BLOCK DIAGRAM (I²C™ MODE)

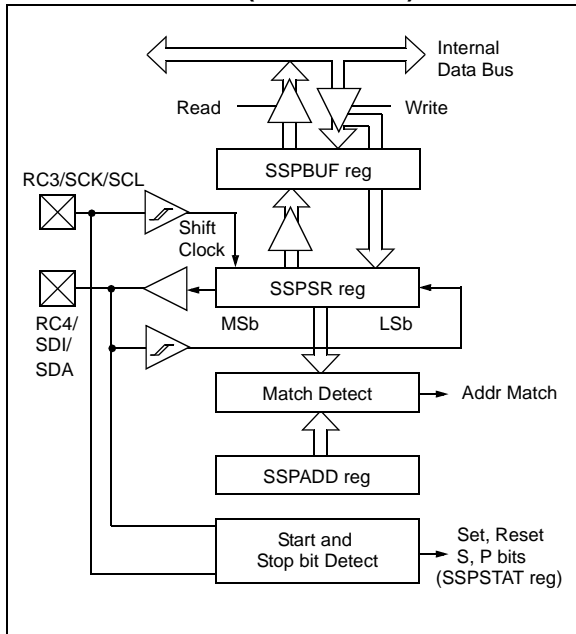

18.4.1 REGISTERS

The MSSP module has six registers for I²C operation. These are:

- MSSP Control Register 1 (SSPCON1)
- MSSP Control Register 2 (SSPCON2)
- MSSP Status Register (SSPSTAT)
- Serial Receive/Transmit Buffer Register (SSPBUF)
- MSSP Shift Register (SSPSR) – Not directly accessible
- MSSP Address Register (SSPADD)

SSPCON1, SSPCON2 and SSPSTAT are the control and status registers in I²C mode operation. The SSPCON1 and SSPCON2 registers are readable and writable. The lower 6 bits of the SSPSTAT are read-only. The upper two bits of the SSPSTAT are read/write.

SSPSR is the shift register used for shifting data in or out. SSPBUF is the buffer register to which data bytes are written to or read from.

SSPADD register holds the slave device address when the MSSP is configured in I²C Slave mode. When the MSSP is configured in Master mode, the lower seven bits of SSPADD act as the Baud Rate Generator reload value.

In receive operations, SSPSR and SSPBUF together create a double-buffered receiver. When SSPSR receives a complete byte, it is transferred to SSPBUF and the SSPIF interrupt is set.

During transmission, the SSPBUF is not double-buffered. A write to SSPBUF will write to both SSPBUF and SSPSR.

PIC18F6525/6621/8525/8621

REGISTER 18-3: SSPSTAT: MSSP STATUS REGISTER (I²C MODE)

R/W-0	R/W-0	R-0	R-0	R-0	R-0	R-0	R-0
SMP	CKE	D/A	P	S	R/W	UA	BF
						bit 0	

- bit 7 **SMP:** Slew Rate Control bit
In Master or Slave mode:
 1 = Slew rate control disabled for Standard Speed mode (100 kHz and 1 MHz)
 0 = Slew rate control enabled for High Speed mode (400 kHz)
- bit 6 **CKE:** SMBus Select bit
In Master or Slave mode:
 1 = Enable SMBus specific inputs
 0 = Disable SMBus specific inputs
- bit 5 **D/A:** Data/Address bit
In Master mode:
 Reserved
In Slave mode:
 1 = Indicates that the last byte received or transmitted was data
 0 = Indicates that the last byte received or transmitted was address
- bit 4 **P:** Stop bit
 1 = Indicates that a Stop bit has been detected last
 0 = Stop bit was not detected last
Note: This bit is cleared on Reset and when SSPEN is cleared.
- bit 3 **S:** Start bit
 1 = Indicates that a Start bit has been detected last
 0 = Start bit was not detected last
Note: This bit is cleared on Reset and when SSPEN is cleared.
- bit 2 **R/W:** Read/Write bit Information (I²C mode only)
In Slave mode:
 1 = Read
 0 = Write
Note: This bit holds the R/W bit information following the last address match. This bit is only valid from the address match to the next Start bit, Stop bit or not ACK bit.
In Master mode:
 1 = Transmit is in progress
 0 = Transmit is not in progress
Note: ORing this bit with SEN, RSEN, PEN, RCEN or ACKEN will indicate if the MSSP is in Idle mode.
- bit 1 **UA:** Update Address bit (10-bit Slave mode only)
 1 = Indicates that the user needs to update the address in the SSPADD register
 0 = Address does not need to be updated
- bit 0 **BF:** Buffer Full Status bit
In Transmit mode:
 1 = SSPBUF is full
 0 = SSPBUF is empty
In Receive mode:
 1 = SSPBUF is full (does not include the ACK and Stop bits)
 0 = SSPBUF is empty (does not include the ACK and Stop bits)

Legend:			
R = Readable bit	W = Writable bit	U = Unimplemented bit, read as '0'	
-n = Value at POR	'1' = Bit is set	'0' = Bit is cleared	x = Bit is unknown

PIC18F6525/6621/8525/8621

REGISTER 18-4: SSPCON1: MSSP CONTROL REGISTER 1 (I²C MODE)

R/W-0	R/W-0	R/W-0	R/W-0	R/W-0	R/W-0	R/W-0	R/W-0
WCOL	SSPOV	SSPEN	CKP	SSPM3	SSPM2	SSPM1	SSPM0
bit 7						bit 0	

bit 7 **WCOL:** Write Collision Detect bit

In Master Transmit mode:

1 = A write to the SSPBUF register was attempted while the I²C conditions were not valid for a transmission to be started (must be cleared in software)

0 = No collision

In Slave Transmit mode:

1 = The SSPBUF register is written while it is still transmitting the previous word (must be cleared in software)

0 = No collision

In Receive mode (Master or Slave modes):

This is a “don’t care” bit.

bit 6 **SSPOV:** Receive Overflow Indicator bit

In Receive mode:

1 = A byte is received while the SSPBUF register is still holding the previous byte (must be cleared in software)

0 = No overflow

In Transmit mode:

This is a “don’t care” bit in Transmit mode.

bit 5 **SSPEN:** Master Synchronous Serial Port Enable bit

1 = Enables the serial port and configures the SDA and SCL pins as the serial port pins

0 = Disables serial port and configures these pins as I/O port pins

Note: When enabled, the SDA and SCL pins must be properly configured as input or output.

bit 4 **CKP:** SCK Release Control bit

In Slave mode:

1 = Release clock

0 = Holds clock low (clock stretch), used to ensure data setup time

In Master mode:

Unused in this mode.

bit 3-0 **SSPM3:SSPM0:** Master Synchronous Serial Port Mode Select bits

1111 = I²C Slave mode, 10-bit address with Start and Stop bit interrupts enabled

1110 = I²C Slave mode, 7-bit address with Start and Stop bit interrupts enabled

1011 = I²C Firmware Controlled Master mode (Slave Idle)

1000 = I²C Master mode, clock = FOSC/(4 * (SSPADD + 1))

0111 = I²C Slave mode, 10-bit address

0110 = I²C Slave mode, 7-bit address

Note: Bit combinations not specifically listed here are either reserved or implemented in SPI mode only.

Legend:

R = Readable bit

W = Writable bit

U = Unimplemented bit, read as ‘0’

-n = Value at POR

‘1’ = Bit is set

‘0’ = Bit is cleared

x = Bit is unknown

PIC18F6525/6621/8525/8621

REGISTER 18-5: SSPCON2: MSSP CONTROL REGISTER 2 (I²C MODE)

R/W-0	R/W-0	R/W-0	R/W-0	R/W-0	R/W-0	R/W-0	R/W-0
GCEN	ACKSTAT	ACKDT	ACKEN	RCEN	PEN	RSEN	SEN
bit 7						bit 0	

- bit 7 **GCEN:** General Call Enable bit (Slave mode only)
 1 = Enable interrupt when a general call address (0000h) is received in the SSPSR
 0 = General call address disabled
- bit 6 **ACKSTAT:** Acknowledge Status bit (Master Transmit mode only)
 1 = Acknowledge was not received from slave
 0 = Acknowledge was received from slave
- bit 5 **ACKDT:** Acknowledge Data bit (Master Receive mode only)
 1 = Not Acknowledge
 0 = Acknowledge
- Note:** Value that will be transmitted when the user initiates an Acknowledge sequence at the end of a receive.
- bit 4 **ACKEN:** Acknowledge Sequence Enable bit (Master Receive mode only)
 1 = Initiate Acknowledge sequence on SDA and SCL pins and transmit ACKDT data bit. Automatically cleared by hardware.
 0 = Acknowledge sequence Idle
- bit 3 **RCEN:** Receive Enable bit (Master mode only)
 1 = Enables Receive mode for I²C
 0 = Receive Idle
- bit 2 **PEN:** Stop Condition Enable bit (Master mode only)
 1 = Initiate Stop condition on SDA and SCL pins. Automatically cleared by hardware.
 0 = Stop condition Idle
- bit 1 **RSEN:** Repeated Start Condition Enable bit (Master mode only)
 1 = Initiate Repeated Start condition on SDA and SCL pins. Automatically cleared by hardware.
 0 = Repeated Start condition Idle
- bit 0 **SEN:** Start Condition Enable/Stretch Enable bit
- In Master mode:
 1 = Initiate Start condition on SDA and SCL pins. Automatically cleared by hardware.
 0 = Start condition Idle
- In Slave mode:
 1 = Clock stretching is enabled for both slave transmit and slave receive (stretch enabled)
 0 = Clock stretching is disabled

Note: For bits ACKEN, RCEN, PEN, RSEN, SEN: If the I²C module is not in the Idle mode, this bit may not be set (no spooling) and the SSPBUF may not be written (or writes to the SSPBUF are disabled).

Legend:

R = Readable bit W = Writable bit U = Unimplemented bit, read as '0'
 -n = Value at POR '1' = Bit is set '0' = Bit is cleared x = Bit is unknown

PIC18F6525/6621/8525/8621

18.4.2 OPERATION

The MSSP module functions are enabled by setting MSSP Enable bit, SSPEN (SSPCON<5>).

The SSPCON1 register allows control of the I²C operation. Four mode selection bits (SSPCON<3:0>) allow one of the following I²C modes to be selected:

- I²C Master mode, clock = (Fosc/4) x (SSPADD + 1)
- I²C Slave mode (7-bit address)
- I²C Slave mode (10-bit address)
- I²C Slave mode (7-bit address), with Start and Stop bit interrupts enabled
- I²C Slave mode (10-bit address), with Start and Stop bit interrupts enabled
- I²C firmware controlled master operation, slave is Idle

Selection of any I²C mode with the SSPEN bit set, forces the SCL and SDA pins to be open-drain, provided these pins are programmed to inputs by setting the appropriate TRISC bits. To ensure proper operation of the module, pull-up resistors must be provided externally to the SCL and SDA pins.

18.4.3 SLAVE MODE

In Slave mode, the SCL and SDA pins must be configured as inputs (TRISC<4:3> set). The MSSP module will override the input state with the output data when required (slave-transmitter).

The I²C Slave mode hardware will always generate an interrupt on an address match. Through the mode select bits, the user can also choose to interrupt on Start and Stop bits

When an address is matched, or the data transfer after an address match is received, the hardware automatically will generate the Acknowledge ($\overline{\text{ACK}}$) pulse and load the SSPBUF register with the received value currently in the SSPSR register.

Any combination of the following conditions will cause the MSSP module not to give this $\overline{\text{ACK}}$ pulse:

- The buffer full bit BF (SSPSTAT<0>) was set before the transfer was received.
- The overflow bit SSPOV (SSPCON<6>) was set before the transfer was received.

In this case, the SSPSR register value is not loaded into the SSPBUF, but bit SSPIF (PIR1<3>) is set. The BF bit is cleared by reading the SSPBUF register, while bit SSPOV is cleared through software.

The SCL clock input must have a minimum high and low for proper operation. The high and low times of the I²C specification, as well as the requirement of the MSSP module, are shown in timing parameter 100 and parameter 101.

18.4.3.1 Addressing

Once the MSSP module has been enabled, it waits for a Start condition to occur. Following the Start condition, the 8-bits are shifted into the SSPSR register. All incoming bits are sampled with the rising edge of the clock (SCL) line. The value of register SSPSR<7:1> is compared to the value of the SSPADD register. The address is compared on the falling edge of the eighth clock (SCL) pulse. If the addresses match and the BF and SSPOV bits are clear, the following events occur:

1. The SSPSR register value is loaded into the SSPBUF register.
2. The buffer full bit BF is set.
3. An $\overline{\text{ACK}}$ pulse is generated.
4. MSSP Interrupt Flag bit, SSPIF (PIR1<3>), is set (interrupt is generated, if enabled) on the falling edge of the ninth SCL pulse.

In 10-bit Address mode, two address bytes need to be received by the slave. The five Most Significant bits (MSBs) of the first address byte specify if this is a 10-bit address. Bit R/W (SSPSTAT<2>) must specify a write so the slave device will receive the second address byte. For a 10-bit address, the first byte would equal '11110 A₉ A₈ 0', where 'A₉' and 'A₈' are the two MSBs of the address. The sequence of events for 10-bit address is as follows, with steps 7 through 9 for the slave-transmitter:

1. Receive first (high) byte of address (bits SSPIF, BF and UA (SSPSTAT<1>) are set).
2. Update the SSPADD register with second (low) byte of address (clears bit UA and releases the SCL line).
3. Read the SSPBUF register (clears bit BF) and clear flag bit SSPIF.
4. Receive second (low) byte of address (bits SSPIF, BF and UA are set).
5. Update the SSPADD register with the first (high) byte of address. If match releases SCL line, this will clear bit UA.
6. Read the SSPBUF register (clears bit BF) and clear flag bit SSPIF.
7. Receive Repeated Start condition.
8. Receive first (high) byte of address (bits SSPIF and BF are set).
9. Read the SSPBUF register (clears bit BF) and clear flag bit SSPIF.

18.4.3.2 Reception

When the $\overline{R/W}$ bit of the address byte is clear and an address match occurs, the $\overline{R/W}$ bit of the SSPSTAT register is cleared. The received address is loaded into the SSPBUF register and the SDA line is held low (\overline{ACK}).

When the address byte overflow condition exists, then the no Acknowledge (\overline{ACK}) pulse is given. An overflow condition is defined as either bit BF (SSPSTAT<0>) is set, or bit SSPOV (SSPCON1<6>) is set.

An MSSP interrupt is generated for each data transfer byte. Flag bit, SSPIF (PIR1<3>), must be cleared in software. The SSPSTAT register is used to determine the status of the byte.

If SEN is enabled (SSPCON1<0> = 1), RC3/SCK/SCL will be held low (clock stretch) following each data transfer. The clock must be released by setting bit CKP (SSPCON<4>). See **Section 18.4.4 “Clock Stretching”** for more detail.

18.4.3.3 Transmission

When the $\overline{R/W}$ bit of the incoming address byte is set and an address match occurs, the $\overline{R/W}$ bit of the SSPSTAT register is set. The received address is loaded into the SSPBUF register. The \overline{ACK} pulse will be sent on the ninth bit and pin RC3/SCK/SCL is held low regardless of SEN (see **Section 18.4.4 “Clock Stretching”** for more detail). By stretching the clock, the master will be unable to assert another clock pulse until the slave is done preparing the transmit data. The transmit data must be loaded into the SSPBUF register which also loads the SSPSR register. Then pin RC3/SCK/SCL should be enabled by setting bit, CKP (SSPCON1<4>). The eight data bits are shifted out on the falling edge of the SCL input. This ensures that the SDA signal is valid during the SCL high time (Figure 18-9).

The \overline{ACK} pulse from the master-receiver is latched on the rising edge of the ninth SCL input pulse. If the SDA line is high (not \overline{ACK}), then the data transfer is complete. In this case, when the \overline{ACK} is latched by the slave, the slave logic is reset (resets SSPSTAT register) and the slave monitors for another occurrence of the Start bit. If the SDA line was low (\overline{ACK}), the next transmit data must be loaded into the SSPBUF register. Again, pin RC3/SCK/SCL must be enabled by setting bit CKP.

An MSSP interrupt is generated for each data transfer byte. The SSPIF bit must be cleared in software and the SSPSTAT register is used to determine the status of the byte. The SSPIF bit is set on the falling edge of the ninth clock pulse.

PIC18F6525/6621/8525/8621

FIGURE 18-8: I²C™ SLAVE MODE TIMING WITH SEN = 0 (RECEPTION, 7-BIT ADDRESS)

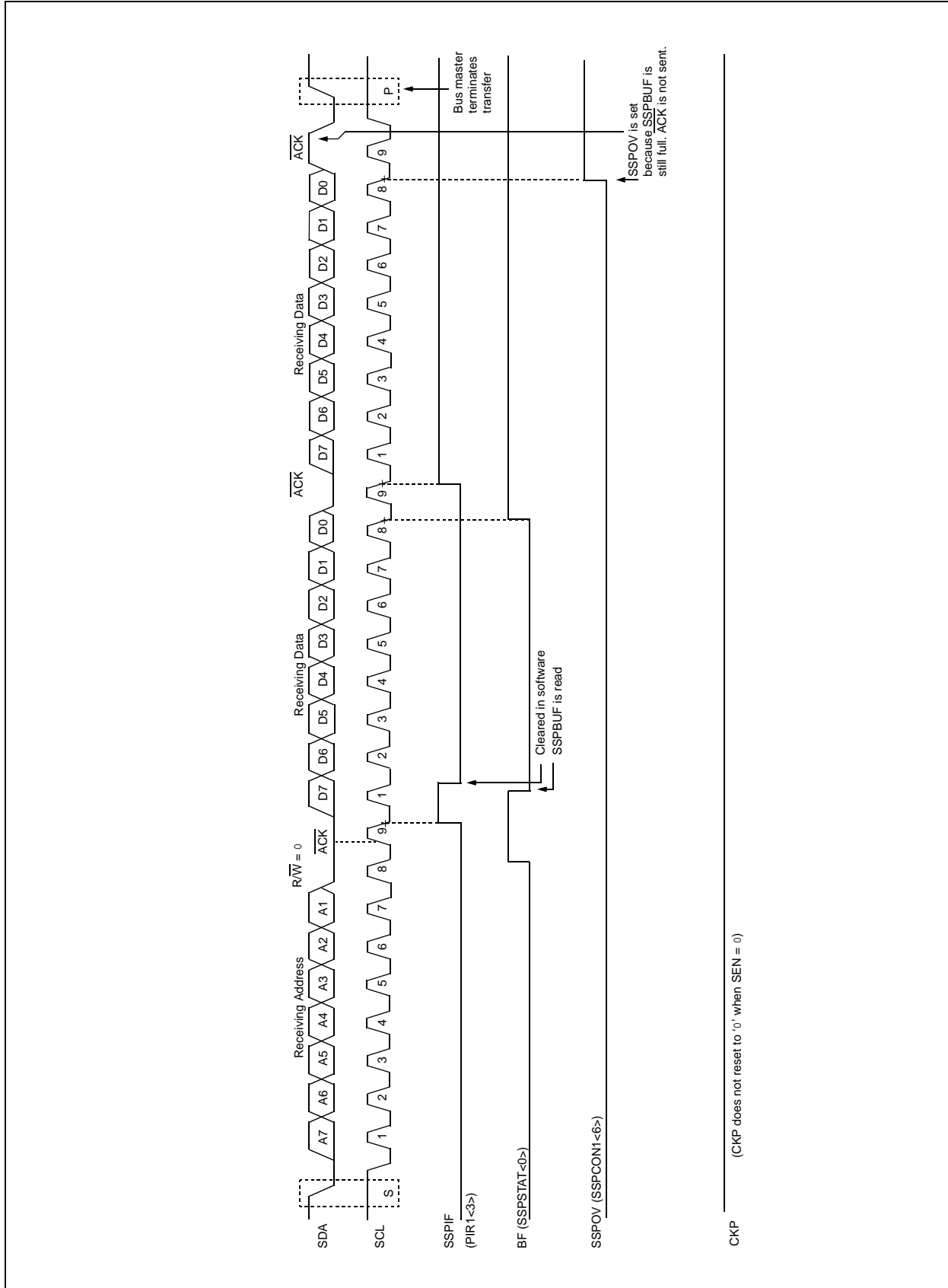

CKP (CKP does not reset to '0' when SEN = 0)

FIGURE 18-9: I²C™ SLAVE MODE TIMING (TRANSMISSION, 7-BIT ADDRESS)

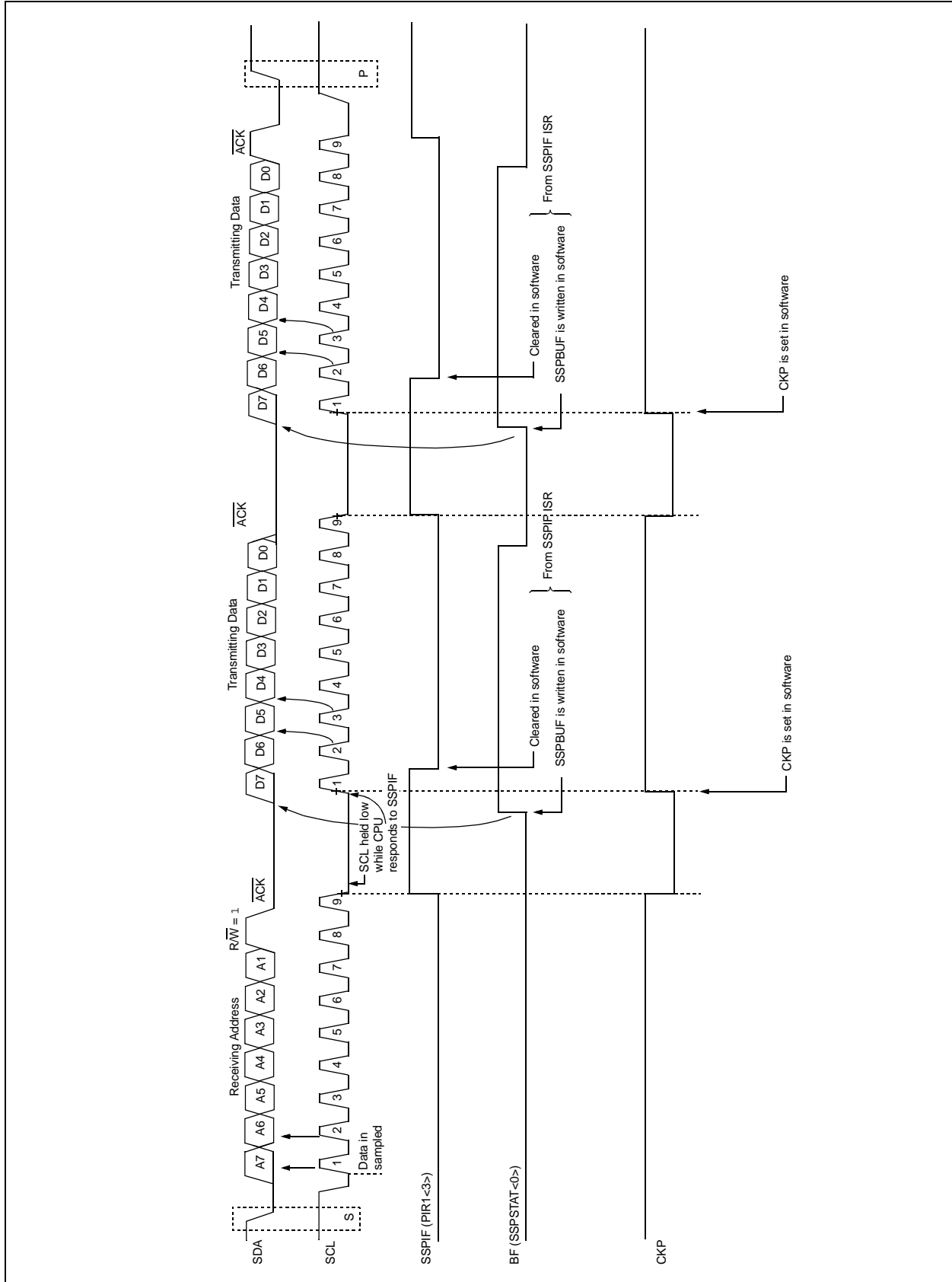

PIC18F6525/6621/8525/8621

FIGURE 18-10: I²C™ SLAVE MODE TIMING WITH SEN = 0 (RECEPTION, 10-BIT ADDRESS)

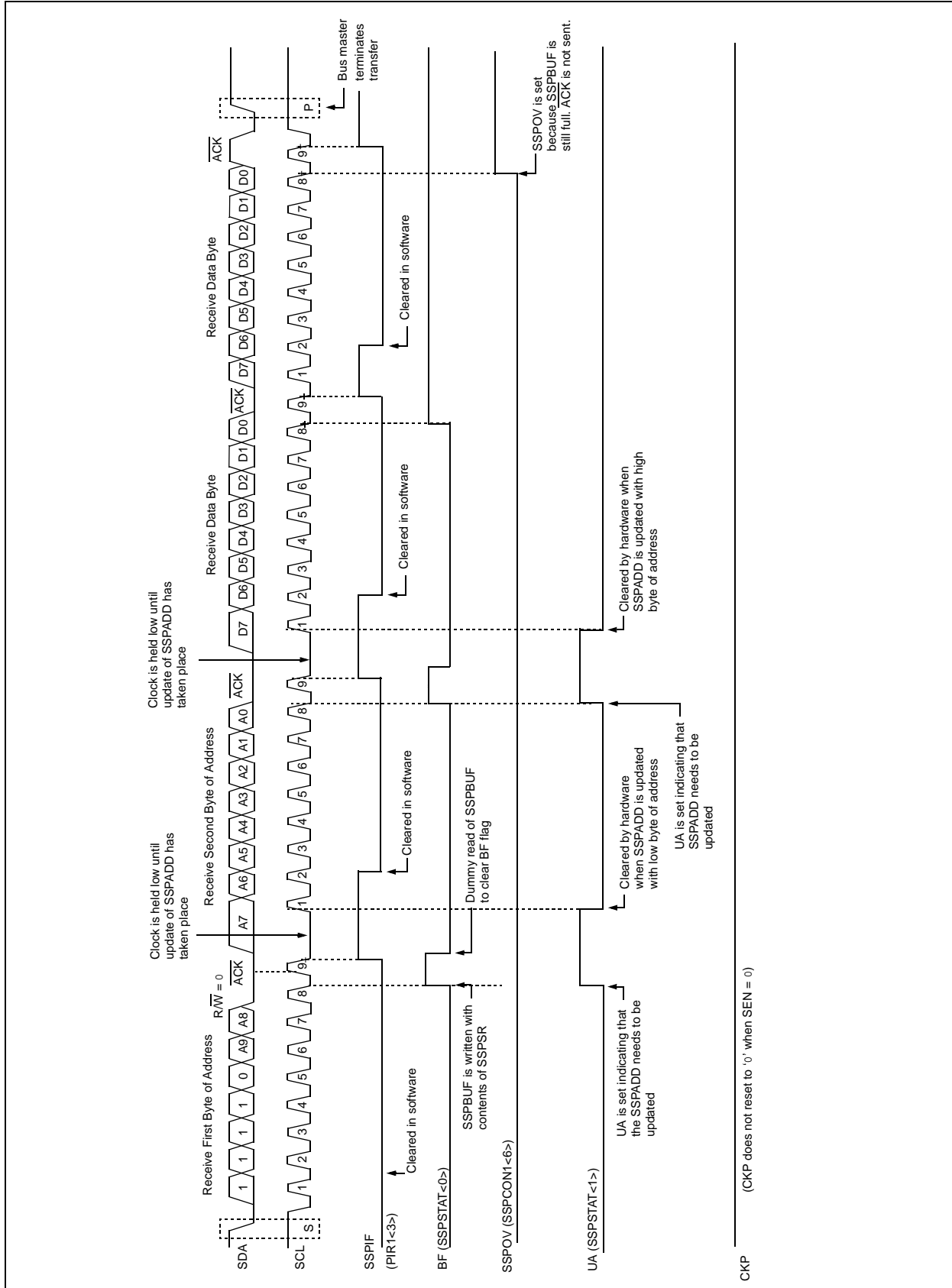
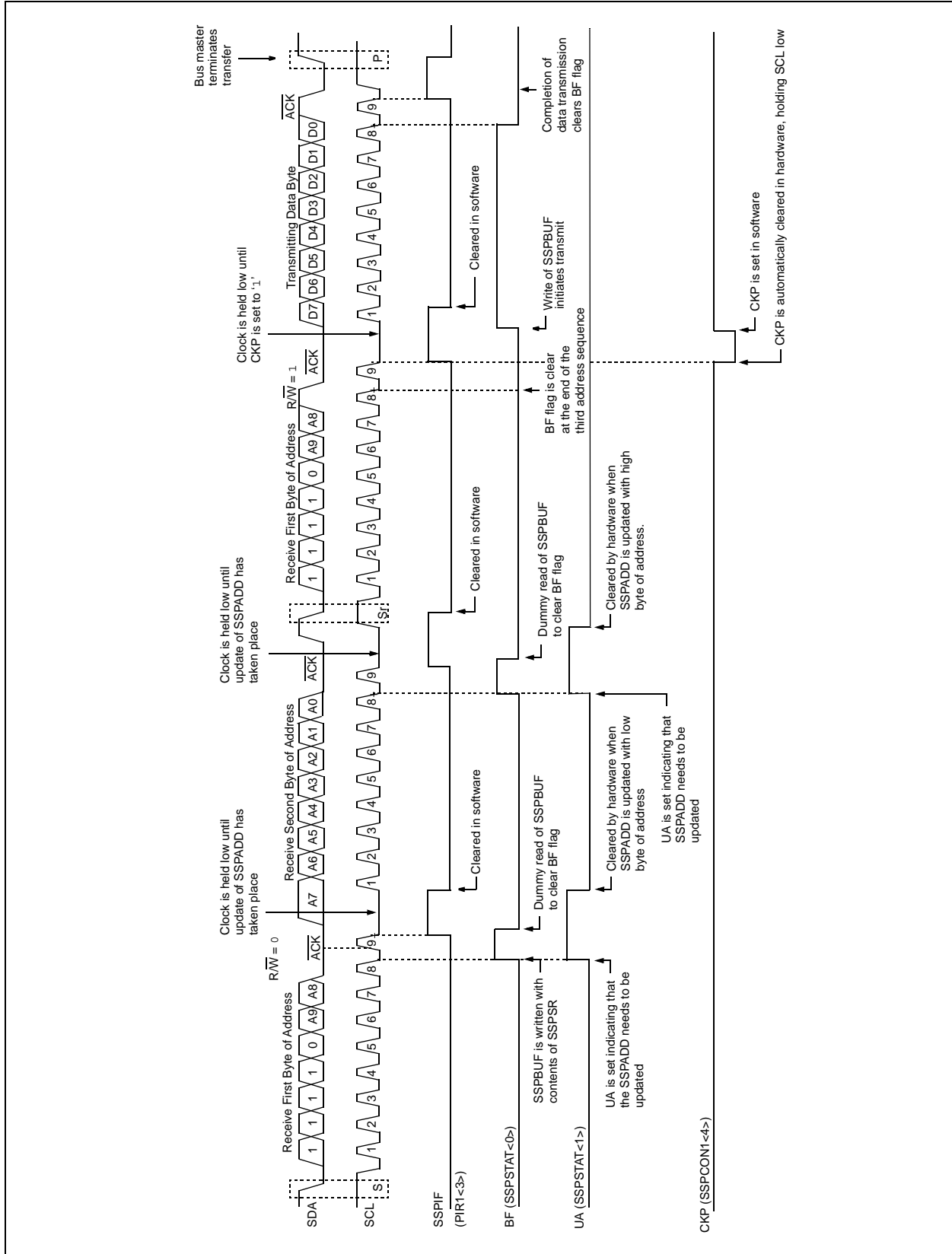

FIGURE 18-11: I²C™ SLAVE MODE TIMING (TRANSMISSION, 10-BIT ADDRESS)



PIC18F6525/6621/8525/8621

18.4.4 CLOCK STRETCHING

Both 7-bit and 10-bit Slave modes implement automatic clock stretching during a transmit sequence.

The SEN bit (SSPCON2<0>) allows clock stretching to be enabled during receives. Setting SEN will cause the SCL pin to be held low at the end of each data receive sequence.

18.4.4.1 Clock Stretching for 7-bit Slave Receive Mode (SEN = 1)

In 7-bit Slave Receive mode, on the falling edge of the ninth clock at the end of the ACK sequence if the BF bit is set, the CKP bit in the SSPCON1 register is automatically cleared, forcing the SCL output to be held low. The CKP being cleared to '0' will assert the SCL line low. The CKP bit must be set in the user's ISR before reception is allowed to continue. By holding the SCL line low, the user has time to service the ISR and read the contents of the SSPBUF before the master device can initiate another receive sequence. This will prevent buffer overruns from occurring (see Figure 18-13).

Note 1: If the user reads the contents of the SSPBUF before the falling edge of the ninth clock, thus clearing the BF bit, the CKP bit will not be cleared and clock stretching will not occur.

2: The CKP bit can be set in software regardless of the state of the BF bit. The user should be careful to clear the BF bit in the ISR before the next receive sequence in order to prevent an overflow condition.

18.4.4.2 Clock Stretching for 10-bit Slave Receive Mode (SEN = 1)

In 10-bit Slave Receive mode during the address sequence, clock stretching automatically takes place but CKP is not cleared. During this time, if the UA bit is set after the ninth clock, clock stretching is initiated. The UA bit is set after receiving the upper byte of the 10-bit address and following the receive of the second byte of the 10-bit address with the R/W bit cleared to '0'. The release of the clock line occurs upon updating SSPADD. Clock stretching will occur on each data receive sequence as described in 7-bit mode.

Note: If the user polls the UA bit and clears it by updating the SSPADD register before the falling edge of the ninth clock occurs and if the user hasn't cleared the BF bit by reading the SSPBUF register before that time, then the CKP bit will still NOT be asserted low. Clock stretching on the basis of the state of the BF bit only occurs during a data sequence, not an address sequence.

18.4.4.3 Clock Stretching for 7-bit Slave Transmit Mode

7-bit Slave Transmit mode implements clock stretching by clearing the CKP bit after the falling edge of the ninth clock if the BF bit is clear. This occurs regardless of the state of the SEN bit.

The user's ISR must set the CKP bit before transmission is allowed to continue. By holding the SCL line low, the user has time to service the ISR and load the contents of the SSPBUF before the master device can initiate another transmit sequence (see Figure 18-9).

Note 1: If the user loads the contents of SSPBUF, setting the BF bit before the falling edge of the ninth clock, the CKP bit will not be cleared and clock stretching will not occur.

2: The CKP bit can be set in software regardless of the state of the BF bit.

18.4.4.4 Clock Stretching for 10-bit Slave Transmit Mode

In 10-bit Slave Transmit mode, clock stretching is controlled during the first two address sequences by the state of the UA bit, just as it is in 10-bit Slave Receive mode. The first two addresses are followed by a third address sequence which contains the high-order bits of the 10-bit address and the R/W bit set to '1'. After the third address sequence is performed, the UA bit is not set, the module is now configured in Transmit mode and clock stretching is controlled by the BF flag as in 7-bit Slave Transmit mode (see Figure 18-11).

PIC18F6525/6621/8525/8621

18.4.4.5 Clock Synchronization and the CKP bit

When the CKP bit is cleared, the SCL output is forced to '0'. However, clearing the CKP bit will not assert the SCL output low until the SCL output is already sampled low. Therefore, the CKP bit will not assert the SCL line until an external I²C master device has

already asserted the SCL line. The SCL output will remain low until the CKP bit is set and all other devices on the I²C bus have deasserted SCL. This ensures that a write to the CKP bit will not violate the minimum high time requirement for SCL (see Figure 18-12).

FIGURE 18-12: CLOCK SYNCHRONIZATION TIMING

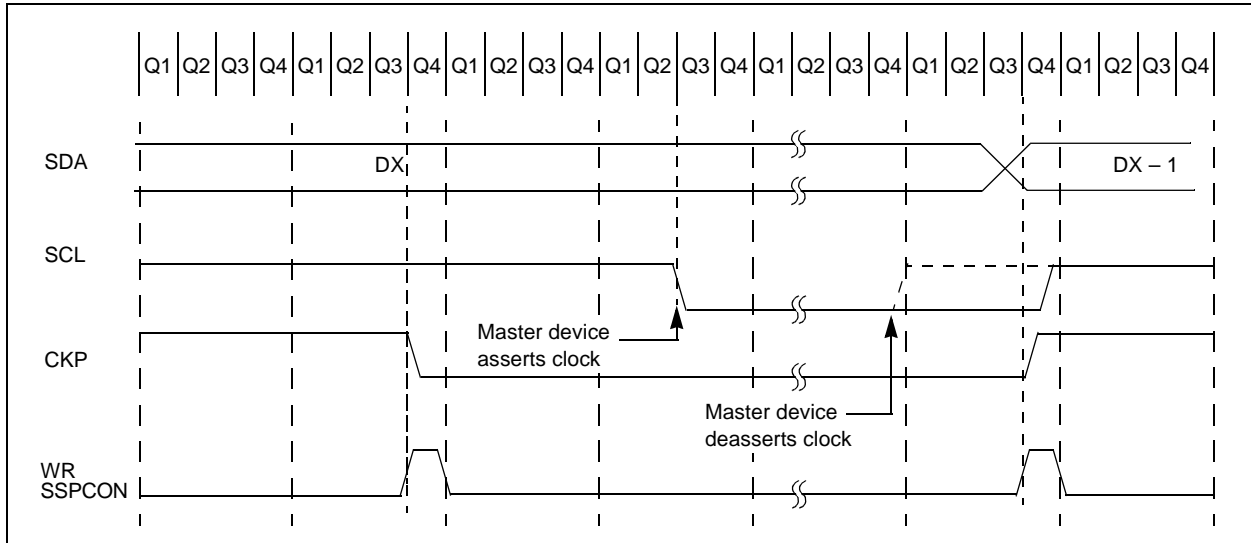

PIC18F6525/6621/8525/8621

FIGURE 18-13: I²C™ SLAVE MODE TIMING WITH SEN = 1 (RECEPTION, 7-BIT ADDRESS)

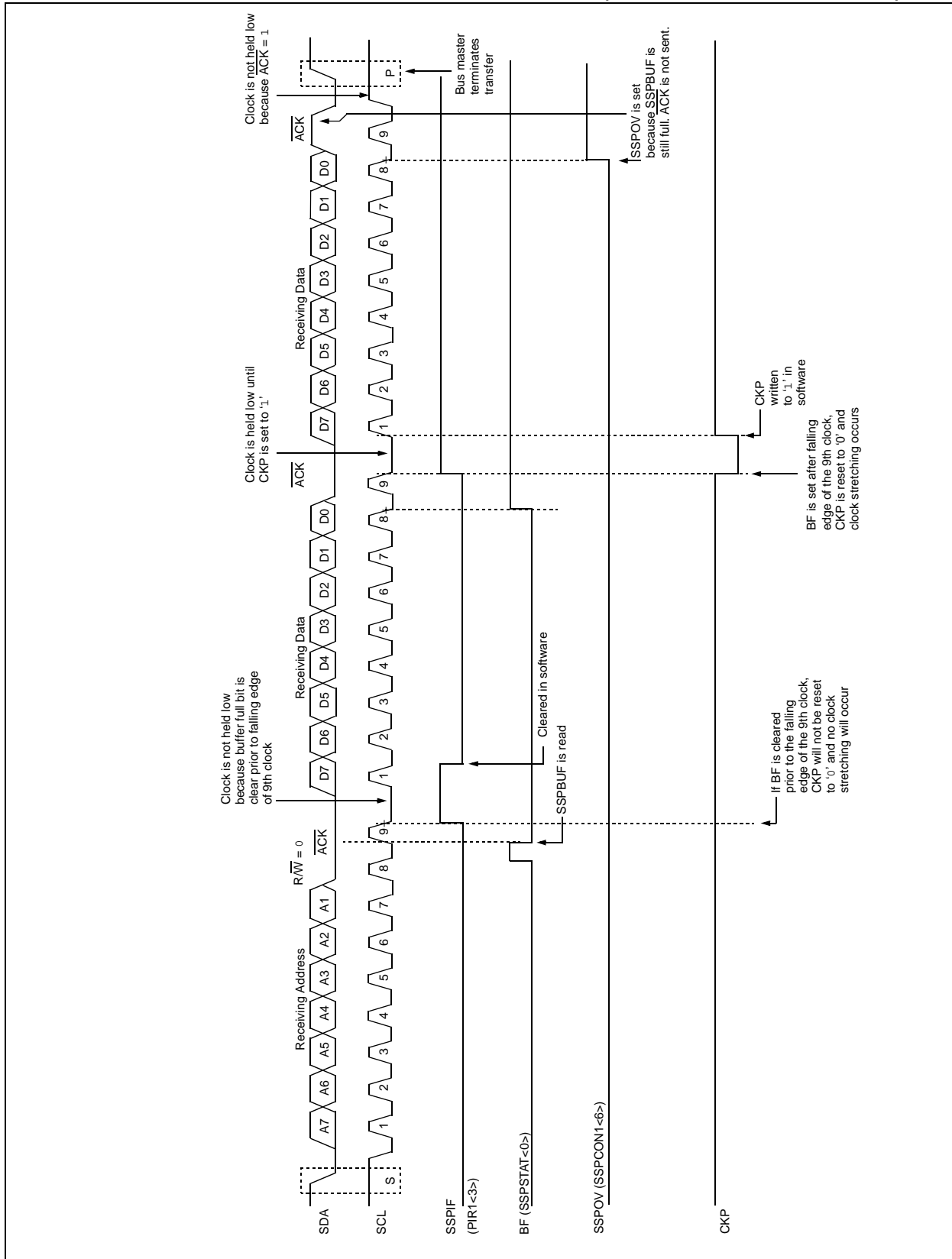
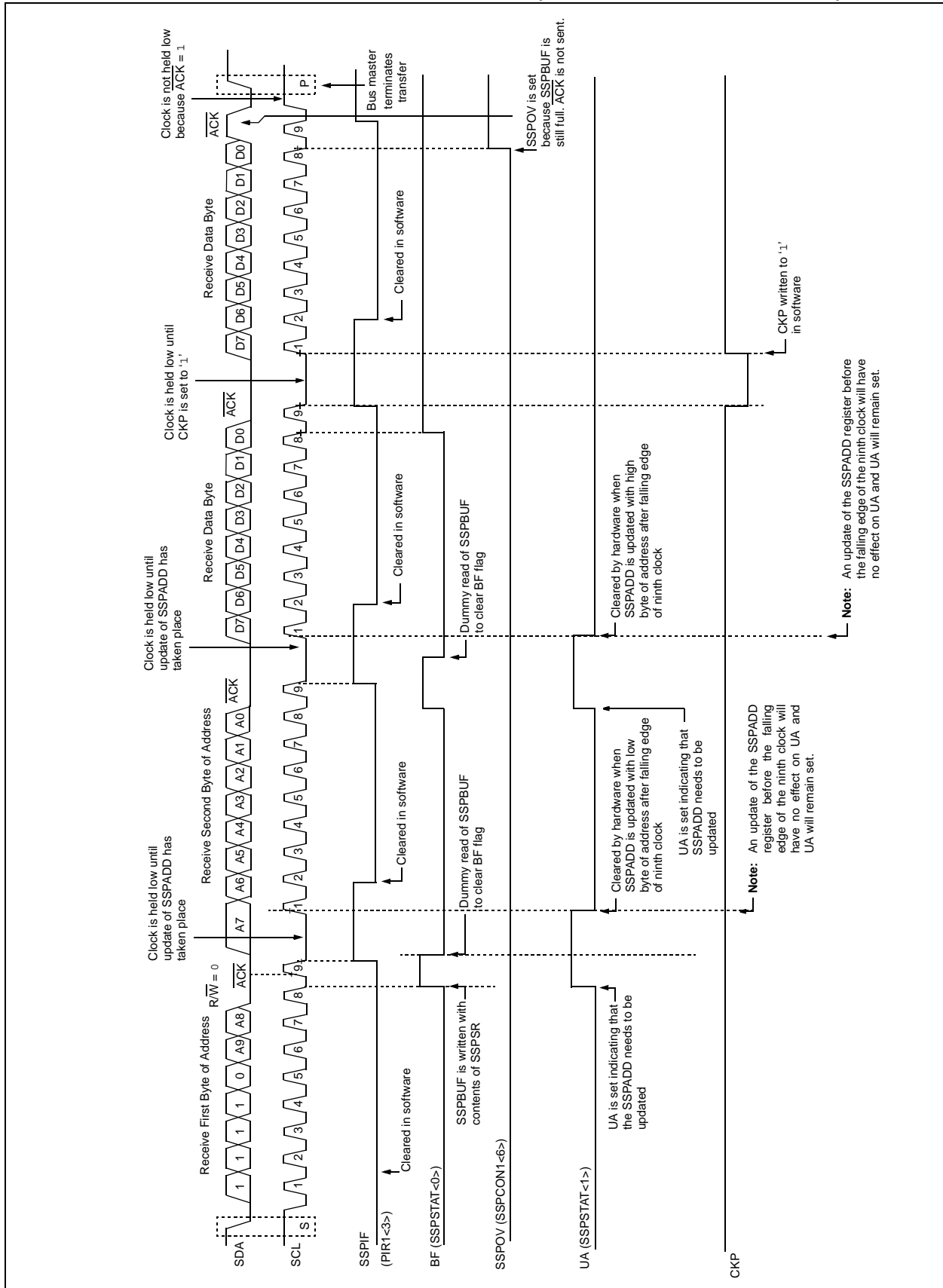

FIGURE 18-14: I²C™ SLAVE MODE TIMING SEN = 1 (RECEPTION, 10-BIT ADDRESS)



PIC18F6525/6621/8525/8621

18.4.5 GENERAL CALL ADDRESS SUPPORT

The addressing procedure for the I²C bus is such that the first byte after the Start condition usually determines which device will be the slave addressed by the master. The exception is the general call address which can address all devices. When this address is used, all devices should, in theory, respond with an Acknowledge.

The general call address is one of eight addresses reserved for specific purposes by the I²C protocol. It consists of all '0's with R/W = 0.

The general call address is recognized when the General Call Enable bit (GCEN) is enabled (SSPCON2<7> set). Following a Start bit detect, 8 bits are shifted into the SSPSR and the address is compared against the SSPADD. It is also compared to the general call address and fixed in hardware.

If the general call address matches, the SSPSR is transferred to the SSPBUF, the BF flag bit is set (eighth bit) and on the falling edge of the ninth bit (\overline{ACK} bit), the SSPIF interrupt flag bit is set.

When the interrupt is serviced, the source for the interrupt can be checked by reading the contents of the SSPBUF. The value can be used to determine if the address was device specific or a general call address.

In 10-bit mode, the SSPADD is required to be updated for the second half of the address to match and the UA bit is set (SSPSTAT<1>). If the general call address is sampled when the GCEN bit is set, while the slave is configured in 10-bit Address mode, then the second half of the address is not necessary, the UA bit will not be set and the slave will begin receiving data after the Acknowledge (Figure 18-15).

FIGURE 18-15: SLAVE MODE GENERAL CALL ADDRESS SEQUENCE (7-BIT OR 10-BIT ADDRESS MODE)

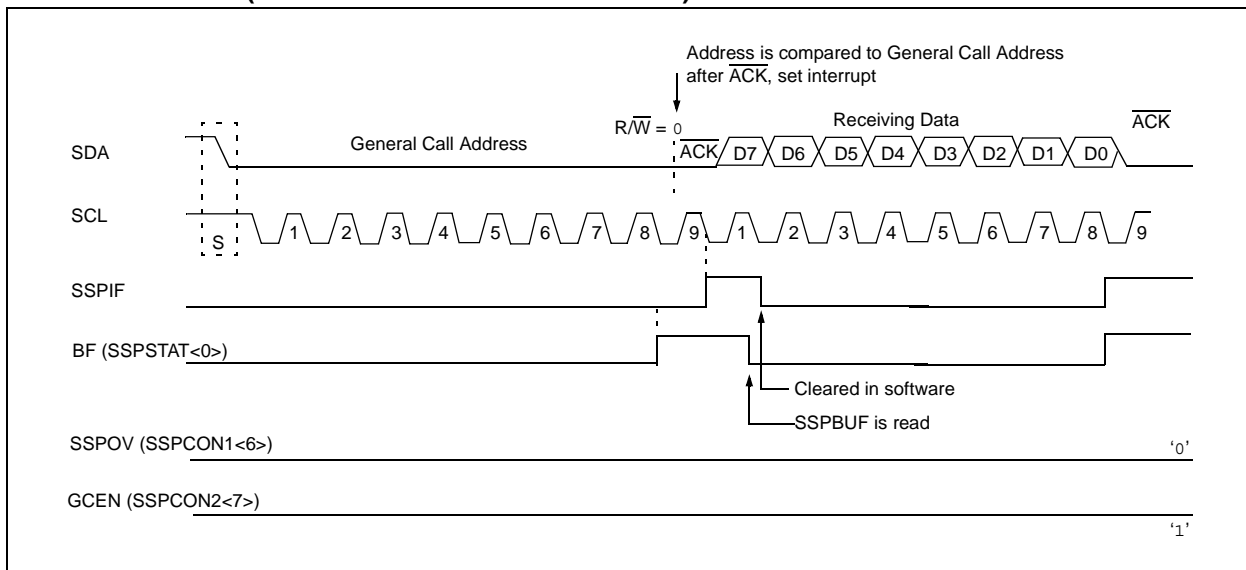

PIC18F6525/6621/8525/8621

18.4.6 MASTER MODE

Master mode is enabled by setting and clearing the appropriate SSPM bits in SSPCON1 and by setting the SSPEN bit. In Master mode, the SCL and SDA lines are manipulated by the MSSP hardware.

Master mode of operation is supported by interrupt generation on the detection of the Start and Stop conditions. The Stop (P) and Start (S) bits are cleared from a Reset or when the MSSP module is disabled. Control of the I²C bus may be taken when the P bit is set or the bus is Idle, with both the S and P bits clear.

In Firmware Controlled Master mode, user code conducts all I²C bus operations based on Start and Stop bit conditions.

Once Master mode is enabled, the user has six options.

1. Assert a Start condition on SDA and SCL.
2. Assert a Repeated Start condition on SDA and SCL.
3. Write to the SSPBUF register initiating transmission of data/address.
4. Configure the I²C port to receive data.
5. Generate an Acknowledge condition at the end of a received byte of data.
6. Generate a Stop condition on SDA and SCL.

Note: The MSSP module, when configured in I²C Master mode, does not allow queueing of events. For instance, the user is not allowed to initiate a Start condition and immediately write the SSPBUF register to initiate transmission before the Start condition is complete. In this case, the SSPBUF will not be written to and the WCOL bit will be set, indicating that a write to the SSPBUF did not occur.

The following events will cause MSSP Interrupt Flag bit, SSPIF, to be set (MSSP interrupt, if enabled):

- Start condition
- Stop condition
- Data transfer byte transmitted/received
- Acknowledge transmit
- Repeated Start

FIGURE 18-16: MSSP BLOCK DIAGRAM (I²C™ MASTER MODE)

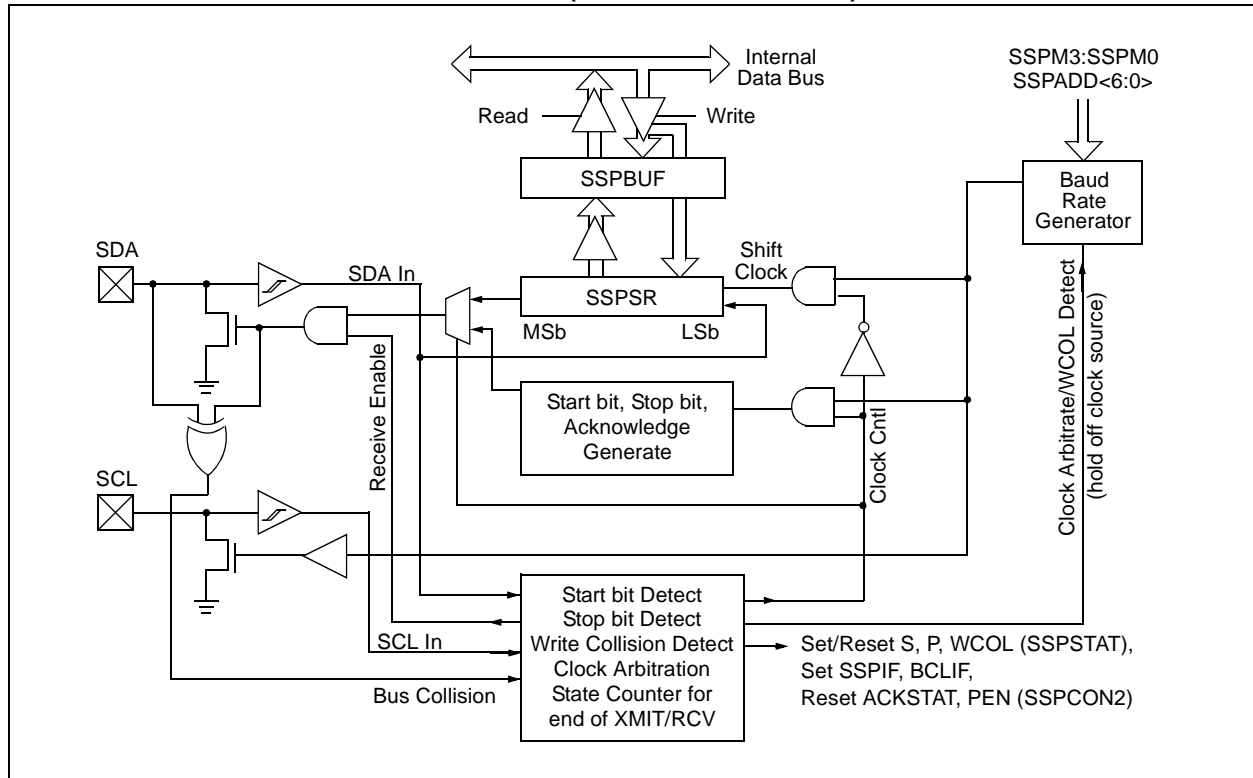

PIC18F6525/6621/8525/8621

18.4.6.1 I²C Master Mode Operation

The master device generates all of the serial clock pulses and the Start and Stop conditions. A transfer is ended with a Stop condition or with a Repeated Start condition. Since the Repeated Start condition is also the beginning of the next serial transfer, the I²C bus will not be released.

In Master Transmitter mode, serial data is output through SDA, while SCL outputs the serial clock. The first byte transmitted contains the slave address of the receiving device (7 bits) and the Read/Write (R/W) bit. In this case, the R/W bit will be logic '0'. Serial data is transmitted 8 bits at a time. After each byte is transmitted, an Acknowledge bit is received. Start and Stop conditions are output to indicate the beginning and the end of a serial transfer.

In Master Receive mode, the first byte transmitted contains the slave address of the transmitting device (7 bits) and the R/W bit. In this case, the R/W bit will be logic '1'. Thus, the first byte transmitted is a 7-bit slave address followed by a '1' to indicate receive bit. Serial data is received via SDA, while SCL outputs the serial clock. Serial data is received 8 bits at a time. After each byte is received, an Acknowledge bit is transmitted. Start and Stop conditions indicate the beginning and end of transmission.

The Baud Rate Generator used for the SPI mode operation is used to set the SCL clock frequency for either 100 kHz, 400 kHz or 1 MHz I²C operation. See **Section 18.4.7 "Baud Rate Generator"** for more detail.

A typical transmit sequence would go as follows:

1. The user generates a Start condition by setting the Start Enable bit, SEN (SSPCON2<0>).
2. SSPIF is set. The MSSP module will wait the required start time before any other operation takes place.
3. The user loads the SSPBUF with the slave address to transmit.
4. Address is shifted out of the SDA pin until all 8 bits are transmitted.
5. The MSSP module shifts in the ACK bit from the slave device and writes its value into the SSPCON2 register (SSPCON2<6>).
6. The MSSP module generates an interrupt at the end of the ninth clock cycle by setting the SSPIF bit.
7. The user loads the SSPBUF with eight bits of data.
8. Data is shifted out of the SDA pin until all 8 bits are transmitted.
9. The MSSP module shifts in the ACK bit from the slave device and writes its value into the SSPCON2 register (SSPCON2<6>).
10. The MSSP module generates an interrupt at the end of the ninth clock cycle by setting the SSPIF bit.
11. The user generates a Stop condition by setting the Stop Enable bit, PEN (SSPCON2<2>).
12. Interrupt is generated once the Stop condition is complete.

PIC18F6525/6621/8525/8621

18.4.7 BAUD RATE GENERATOR

In I²C Master mode, the Baud Rate Generator (BRG) reload value is placed in the lower 7 bits of the SSPADD register (Figure 18-17). When a write occurs to SSPBUF, the Baud Rate Generator will automatically begin counting. The BRG counts down to '0' and stops until another reload has taken place. The BRG count is decremented twice per instruction cycle (T_{cy}) on the Q2 and Q4 clocks. In I²C Master mode, the BRG is reloaded automatically.

Once the given operation is complete (i.e., transmission of the last data bit is followed by ACK), the internal clock will automatically stop counting and the SCL pin will remain in its last state.

Table 18-3 demonstrates clock rates based on instruction cycles and the BRG value loaded into SSPADD.

FIGURE 18-17: BAUD RATE GENERATOR BLOCK DIAGRAM

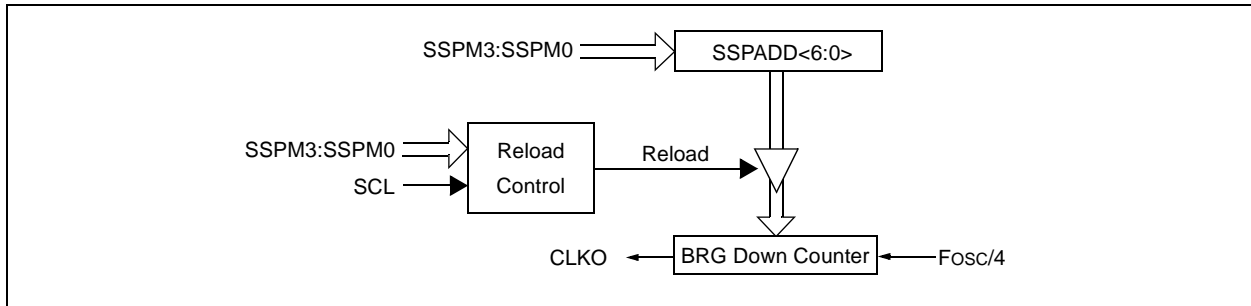

TABLE 18-3: I²C™ CLOCK RATE w/BRG

Fosc	Fcy	Fcy*2	BRG Value	Fscl (2 Rollovers of BRG)
40 MHz	10 MHz	20 MHz	18h	400 kHz ⁽¹⁾
40 MHz	10 MHz	20 MHz	1Fh	312.5 kHz
40 MHz	10 MHz	20 MHz	63h	100 kHz
16 MHz	4 MHz	8 MHz	09h	400 kHz ⁽¹⁾
16 MHz	4 MHz	8 MHz	0Ch	308 kHz
16 MHz	4 MHz	8 MHz	27h	100 kHz
4 MHz	1 MHz	2 MHz	02h	333 kHz ⁽¹⁾
4 MHz	1 MHz	2 MHz	09h	100 kHz
4 MHz	1 MHz	2 MHz	00h	1 MHz ⁽¹⁾

Note 1: The I²C interface does not conform to the 400 kHz I²C specification (which applies to rates greater than 100 kHz) in all details, but may be used with care where higher rates are required by the application.

PIC18F6525/6621/8525/8621

18.4.7.1 Clock Arbitration

Clock arbitration occurs when the master, during any receive, transmit or Repeated Start/Stop condition, deasserts the SCL pin (SCL allowed to float high). When the SCL pin is allowed to float high, the Baud Rate Generator (BRG) is suspended from counting until the SCL pin is actually sampled high. When the

SCL pin is sampled high, the Baud Rate Generator is reloaded with the contents of SSPADD<6:0> and begins counting. This ensures that the SCL high time will always be at least one BRG rollover count in the event that the clock is held low by an external device (Figure 18-18).

FIGURE 18-18: BAUD RATE GENERATOR TIMING WITH CLOCK ARBITRATION

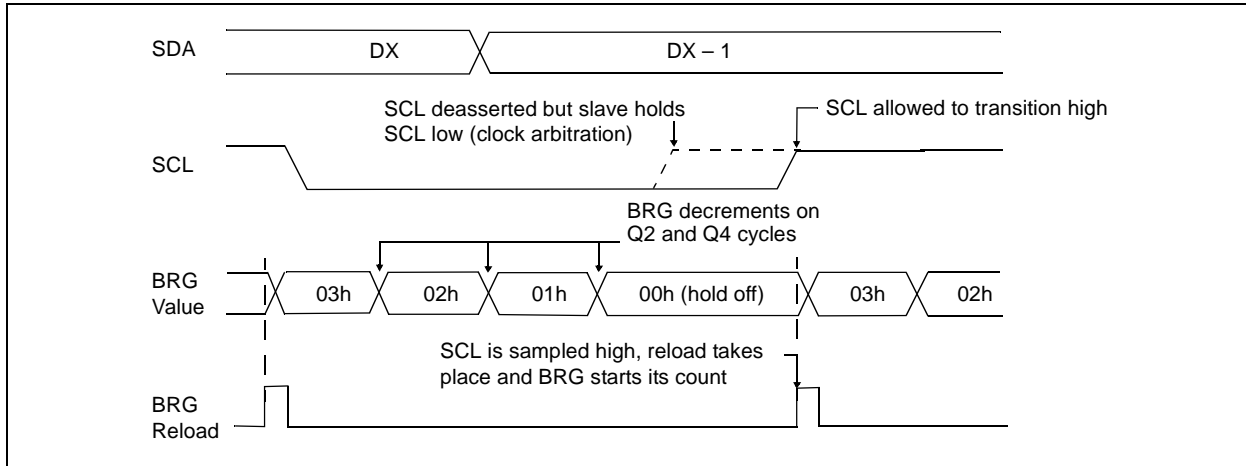

18.4.8 I²C MASTER MODE START CONDITION TIMING

To initiate a Start condition, the user sets the Start condition enable bit, SEN (SSPCON2<0>). If the SDA and SCL pins are sampled high, the Baud Rate Generator is reloaded with the contents of SSPADD<6:0> and starts its count. If SCL and SDA are both sampled high when the Baud Rate Generator times out (TBRG), the SDA pin is driven low. The action of the SDA being driven low while SCL is high is the Start condition and causes the S bit (SSPSTAT<3>) to be set. Following this, the Baud Rate Generator is reloaded with the contents of SSPADD<6:0> and resumes its count. When the Baud Rate Generator times out (TBRG), the SEN bit (SSPCON2<0>) will be automatically cleared by hardware, the Baud Rate Generator is suspended, leaving the SDA line held low and the Start condition is complete.

Note: If at the beginning of the Start condition, the SDA and SCL pins are already sampled low, or if during the Start condition, the SCL line is sampled low before the SDA line is driven low, a bus collision occurs, the Bus Collision Interrupt Flag, BCLIF, is set, the Start condition is aborted and the I²C module is reset into its Idle state.

18.4.8.1 WCOL Status Flag

If the user writes the SSPBUF when a Start sequence is in progress, the WCOL is set and the contents of the buffer are unchanged (the write doesn't occur).

Note: Because queueing of events is not allowed, writing to the lower 5 bits of SSPCON2 is disabled until the Start condition is complete.

FIGURE 18-19: FIRST START BIT TIMING

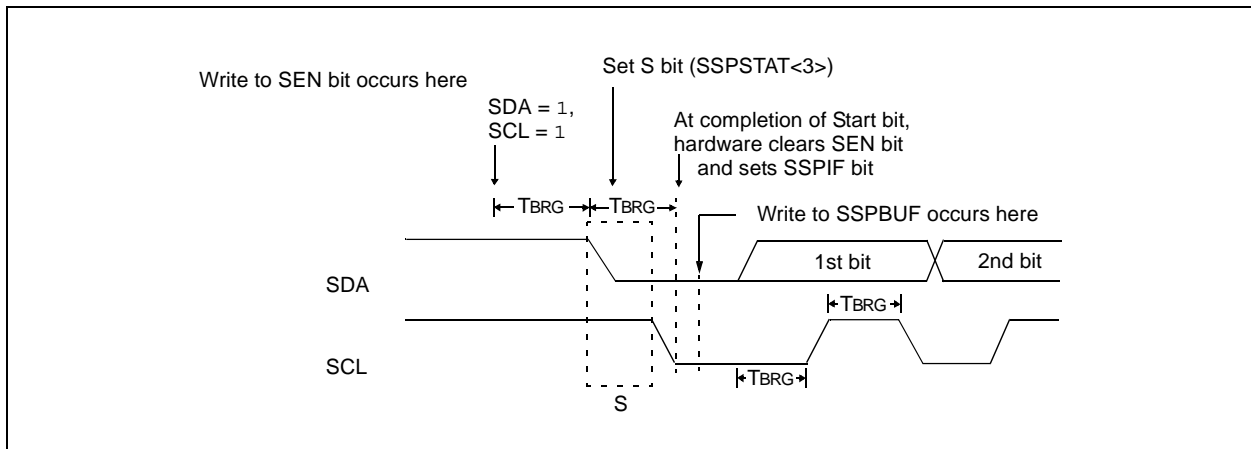

PIC18F6525/6621/8525/8621

18.4.9 I²C MASTER MODE REPEATED START CONDITION TIMING

A Repeated Start condition occurs when the RSEN bit (SSPCON2<1>) is programmed high and the I²C logic module is in the Idle state. When the RSEN bit is set, the SCL pin is asserted low. When the SCL pin is sampled low, the Baud Rate Generator is loaded with the contents of SSPADD<5:0> and begins counting. The SDA pin is released (brought high) for one Baud Rate Generator count (TBRG). When the Baud Rate Generator times out, if SDA is sampled high, the SCL pin will be deasserted (brought high). When SCL is sampled high, the Baud Rate Generator is reloaded with the contents of SSPADD<6:0> and begins counting. SDA and SCL must be sampled high for one TBRG. This action is then followed by assertion of the SDA pin (SDA = 0) for one TBRG while SCL is high. Following this, the RSEN bit (SSPCON2<1>) will be automatically cleared and the Baud Rate Generator will not be reloaded, leaving the SDA pin held low. As soon as a Start condition is detected on the SDA and SCL pins, the S bit (SSPSTAT<3>) will be set. The SSPIF bit will not be set until the Baud Rate Generator has timed out.

Note 1: If RSEN is programmed while any other event is in progress, it will not take effect.

2: A bus collision during the Repeated Start condition occurs if:

- SDA is sampled low when SCL goes from low-to-high.
- SCL goes low before SDA is asserted low. This may indicate that another master is attempting to transmit a data '1'.

Immediately following the SSPIF bit getting set, the user may write the SSPBUF with the 7-bit address in 7-bit mode, or the default first address in 10-bit mode. After the first eight bits are transmitted and an ACK is received, the user may then transmit an additional eight bits of address (10-bit mode) or eight bits of data (7-bit mode).

18.4.9.1 WCOL Status Flag

If the user writes the SSPBUF when a Repeated Start sequence is in progress, the WCOL is set and the contents of the buffer are unchanged (the write doesn't occur).

Note: Because queueing of events is not allowed, writing of the lower 5 bits of SSPCON2 is disabled until the Repeated Start condition is complete.

FIGURE 18-20: REPEATED START CONDITION WAVEFORM

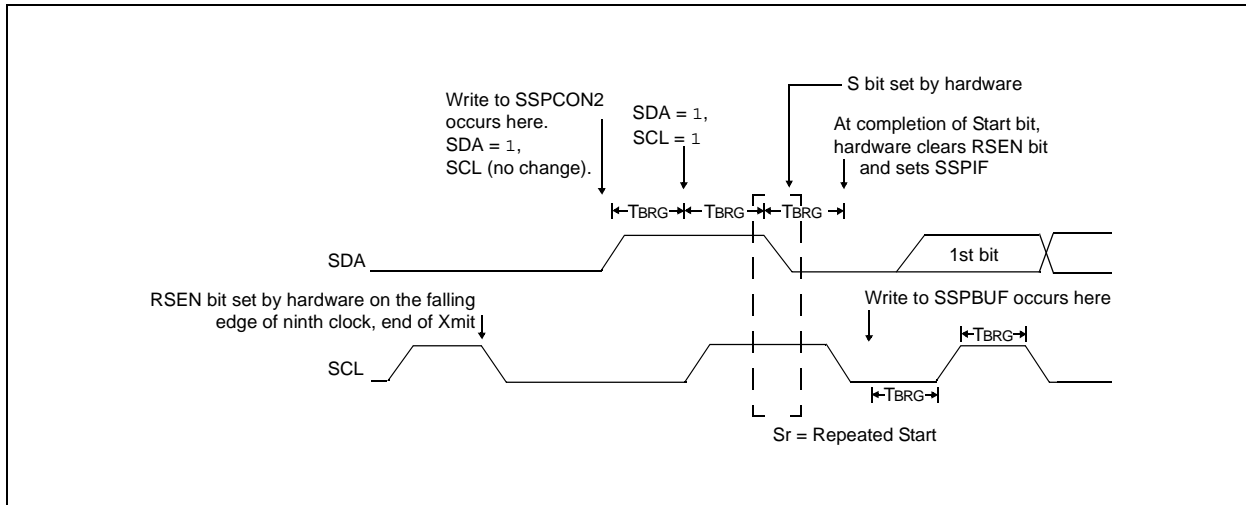

18.4.10 I²C MASTER MODE TRANSMISSION

Transmission of a data byte, a 7-bit address or the other half of a 10-bit address is accomplished by simply writing a value to the SSPBUF register. This action will set the buffer full flag bit, BF and allow the Baud Rate Generator to begin counting and start the next transmission. Each bit of address/data will be shifted out onto the SDA pin after the falling edge of SCL is asserted (see data hold time specification parameter 106). SCL is held low for one Baud Rate Generator rollover count (TBRG). Data should be valid before SCL is released high (see data setup time specification parameter 107). When the SCL pin is released high, it is held that way for TBRG. The data on the SDA pin must remain stable for that duration and some hold time after the next falling edge of SCL. After the eighth bit is shifted out (the falling edge of the eighth clock), the BF flag is cleared and the master releases SDA. This allows the slave device being addressed to respond with an $\overline{\text{ACK}}$ bit during the ninth bit time if an address match occurred, or if data was received properly. The status of $\overline{\text{ACK}}$ is written into the ACKDT bit on the falling edge of the ninth clock. If the master receives an Acknowledge, the Acknowledge status bit, ACKSTAT, is cleared. If not, the bit is set. After the ninth clock, the SSPIF bit is set and the master clock (Baud Rate Generator) is suspended until the next data byte is loaded into the SSPBUF, leaving SCL low and SDA unchanged (Figure 18-21).

After the write to the SSPBUF, each bit of address will be shifted out on the falling edge of SCL until all seven address bits and the R/W bit are completed. On the falling edge of the eighth clock, the master will deassert the SDA pin, allowing the slave to respond with an Acknowledge. On the falling edge of the ninth clock, the master will sample the SDA pin to see if the address was recognized by a slave. The status of the $\overline{\text{ACK}}$ bit is loaded into the ACKSTAT status bit (SSPCON2<6>). Following the falling edge of the ninth clock transmission of the address, the SSPIF is set, the BF flag is cleared and the Baud Rate Generator is turned off until another write to the SSPBUF takes place, holding SCL low and allowing SDA to float.

18.4.10.1 BF Status Flag

In Transmit mode, the BF bit (SSPSTAT<0>) is set when the CPU writes to SSPBUF and is cleared when all 8 bits are shifted out.

18.4.10.2 WCOL Status Flag

If the user writes the SSPBUF when a transmit is already in progress (i.e., SSPSR is still shifting out a data byte), the WCOL is set and the contents of the buffer are unchanged (the write doesn't occur).

WCOL must be cleared in software.

18.4.10.3 ACKSTAT Status Flag

In Transmit mode, the ACKSTAT bit (SSPCON2<6>) is cleared when the slave has sent an Acknowledge ($\overline{\text{ACK}} = 0$) and is set when the slave does not Acknowledge ($\overline{\text{ACK}} = 1$). A slave sends an Acknowledge when it has recognized its address (including a general call), or when the slave has properly received its data.

18.4.11 I²C MASTER MODE RECEPTION

Master mode reception is enabled by programming the receive enable bit, RCEN (SSPCON2<3>).

Note:	The MSSP module must be in an Idle state before the RCEN bit is set or the RCEN bit will be disregarded.
--------------	--

The Baud Rate Generator begins counting and on each rollover, the state of the SCL pin changes (high-to-low/low-to-high) and data is shifted into the SSPSR. After the falling edge of the eighth clock, the receive enable flag is automatically cleared, the contents of the SSPSR are loaded into the SSPBUF, the BF flag bit is set, the SSPIF flag bit is set and the Baud Rate Generator is suspended from counting, holding SCL low. The MSSP is now in Idle state awaiting the next command. When the buffer is read by the CPU, the BF flag bit is automatically cleared. The user can then send an Acknowledge bit at the end of reception by setting the Acknowledge sequence enable bit, ACKEN (SSPCON2<4>).

18.4.11.1 BF Status Flag

In receive operation, the BF bit is set when an address or data byte is loaded into SSPBUF from SSPSR. It is cleared when the SSPBUF register is read.

18.4.11.2 SSPOV Status Flag

In receive operation, the SSPOV bit is set when 8 bits are received into the SSPSR and the BF flag bit is already set from a previous reception.

18.4.11.3 WCOL Status Flag

If the user writes the SSPBUF when a receive is already in progress (i.e., SSPSR is still shifting in a data byte), the WCOL bit is set and the contents of the buffer are unchanged (the write doesn't occur).

PIC18F6525/6621/8525/8621

FIGURE 18-21: I²C™ MASTER MODE WAVEFORM (TRANSMISSION, 7 OR 10-BIT ADDRESS)

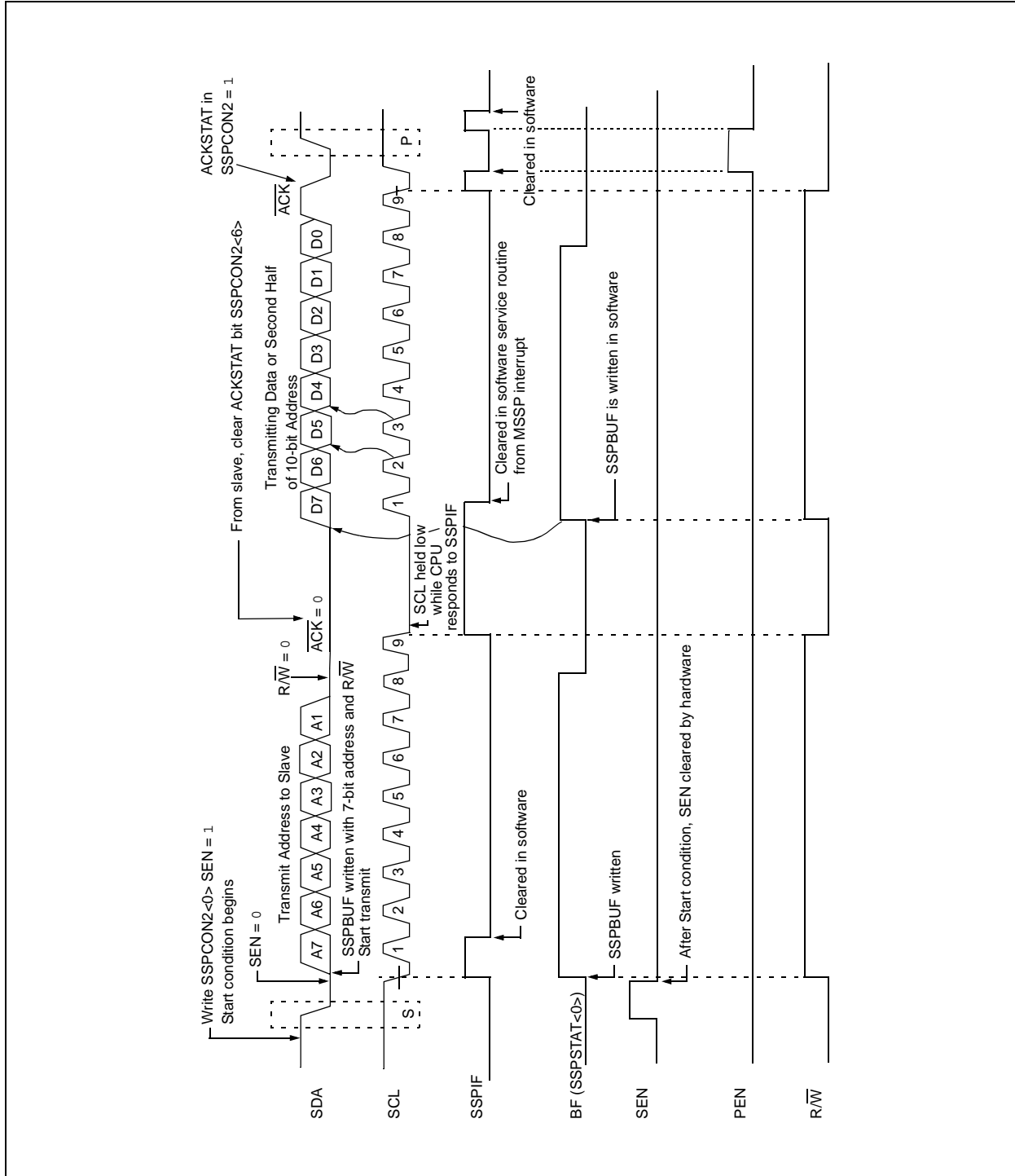
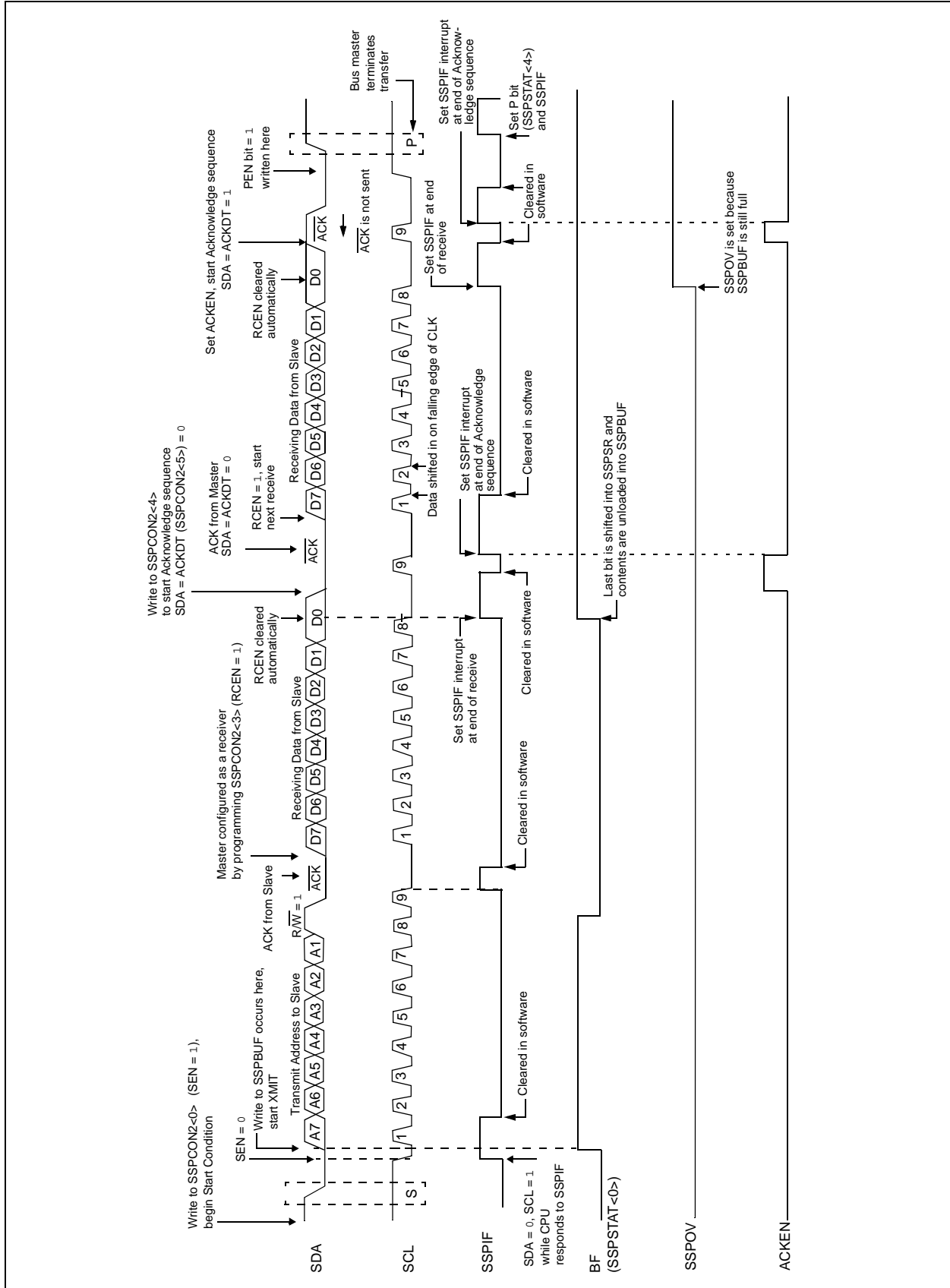

FIGURE 18-22: I²C™ MASTER MODE WAVEFORM (RECEPTION, 7-BIT ADDRESS)



PIC18F6525/6621/8525/8621

18.4.12 ACKNOWLEDGE SEQUENCE TIMING

An Acknowledge sequence is enabled by setting the Acknowledge sequence enable bit, ACKEN (SSPCON2<4>). When this bit is set, the SCL pin is pulled low and the contents of the Acknowledge data bit are presented on the SDA pin. If the user wishes to generate an Acknowledge, then the ACKDT bit should be cleared. If not, the user should set the ACKDT bit before starting an Acknowledge sequence. The Baud Rate Generator then counts for one rollover period (TBRG) and the SCL pin is deasserted (pulled high). When the SCL pin is sampled high (clock arbitration), the Baud Rate Generator counts for TBRG. The SCL pin is then pulled low. Following this, the ACKEN bit is automatically cleared, the Baud Rate Generator is turned off and the MSSP module then goes into Idle mode (Figure 18-23).

18.4.12.1 WCOL Status Flag

If the user writes the SSPBUF when an Acknowledge sequence is in progress, then WCOL is set and the contents of the buffer are unchanged (the write doesn't occur).

18.4.13 STOP CONDITION TIMING

A Stop bit is asserted on the SDA pin at the end of a receive/transmit by setting the Stop sequence enable bit, PEN (SSPCON2<2>). At the end of a receive/transmit, the SCL line is held low after the falling edge of the ninth clock. When the PEN bit is set, the master will assert the SDA line low. When the SDA line is sampled low, the Baud Rate Generator is reloaded and counts down to '0'. When the Baud Rate Generator times out, the SCL pin will be brought high and one TBRG (Baud Rate Generator rollover count) later, the SDA pin will be deasserted. When the SDA pin is sampled high while SCL is high, the P bit (SSPSTAT<4>) is set. A TBRG later, the PEN bit is cleared and the SSPIF bit is set (Figure 18-24).

18.4.13.1 WCOL Status Flag

If the user writes the SSPBUF when a Stop sequence is in progress, then the WCOL bit is set and the contents of the buffer are unchanged (the write doesn't occur).

FIGURE 18-23: ACKNOWLEDGE SEQUENCE WAVEFORM

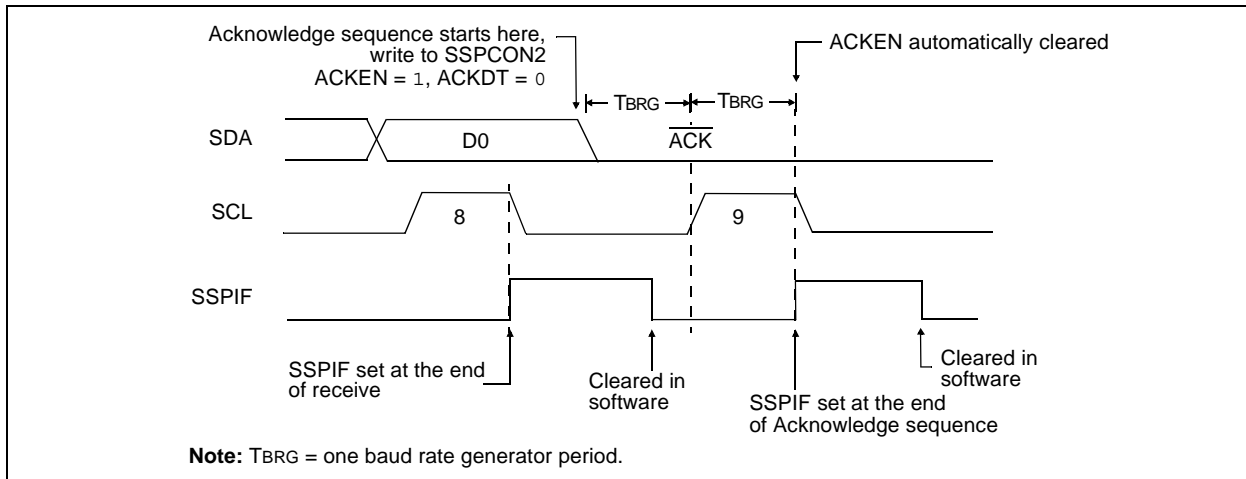
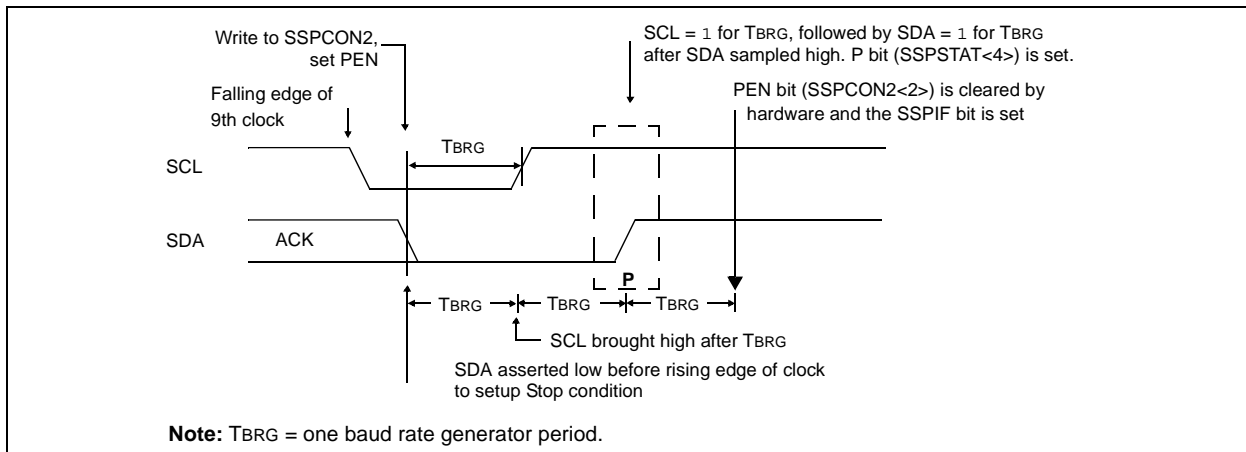

FIGURE 18-24: STOP CONDITION RECEIVE OR TRANSMIT MODE



18.4.14 SLEEP OPERATION

While in Sleep mode, the I²C module can receive addresses or data and when an address match or complete byte transfer occurs, wake the processor from Sleep (if the MSSP interrupt is enabled).

18.4.15 EFFECT OF A RESET

A Reset disables the MSSP module and terminates the current transfer.

18.4.16 MULTI-MASTER MODE

In Multi-Master mode, the interrupt generation on the detection of the Start and Stop conditions allows the determination of when the bus is free. The Stop (P) and Start (S) bits are cleared from a Reset or when the MSSP module is disabled. Control of the I²C bus may be taken when the P bit (SSPSTAT<4>) is set, or the bus is Idle with both the S and P bits clear. When the bus is busy, enabling the MSSP interrupt will generate the interrupt when the Stop condition occurs.

In multi-master operation, the SDA line must be monitored for arbitration to see if the signal level is the expected output level. This check is performed in hardware with the result placed in the BCLIF bit.

The states where arbitration can be lost are:

- Address Transfer
- Data Transfer
- A Start Condition
- A Repeated Start Condition
- An Acknowledge Condition

18.4.17 MULTI-MASTER COMMUNICATION, BUS COLLISION AND BUS ARBITRATION

Multi-Master mode support is achieved by bus arbitration. When the master outputs address/data bits onto the SDA pin, arbitration takes place when the master outputs a '1' on SDA, by letting SDA float high and another master asserts a '0'. When the SCL pin floats high, data should be stable. If the expected data on SDA is a '1' and the data sampled on the SDA pin = 0, then a bus collision has taken place. The master will set the Bus Collision Interrupt Flag, BCLIF and reset the I²C port to its Idle state (Figure 18-25).

If a transmit was in progress when the bus collision occurred, the transmission is halted, the BF flag is cleared, the SDA and SCL lines are deasserted and the SSPBUF can be written to. When the user services the bus collision Interrupt Service Routine and if the I²C bus is free, the user can resume communication by asserting a Start condition.

If a Start, Repeated Start, Stop or Acknowledge condition was in progress when the bus collision occurred, the condition is aborted, the SDA and SCL lines are deasserted and the respective control bits in the SSPCON2 register are cleared. When the user services the bus collision Interrupt Service Routine and if the I²C bus is free, the user can resume communication by asserting a Start condition.

The master will continue to monitor the SDA and SCL pins. If a Stop condition occurs, the SSPIF bit will be set.

A write to the SSPBUF will start the transmission of data at the first data bit regardless of where the transmitter left off when the bus collision occurred.

In Multi-Master mode, the interrupt generation on the detection of Start and Stop conditions allows the determination of when the bus is free. Control of the I²C bus can be taken when the P bit is set in the SSPSTAT register, or the bus is Idle and the S and P bits are cleared.

FIGURE 18-25: BUS COLLISION TIMING FOR TRANSMIT AND ACKNOWLEDGE

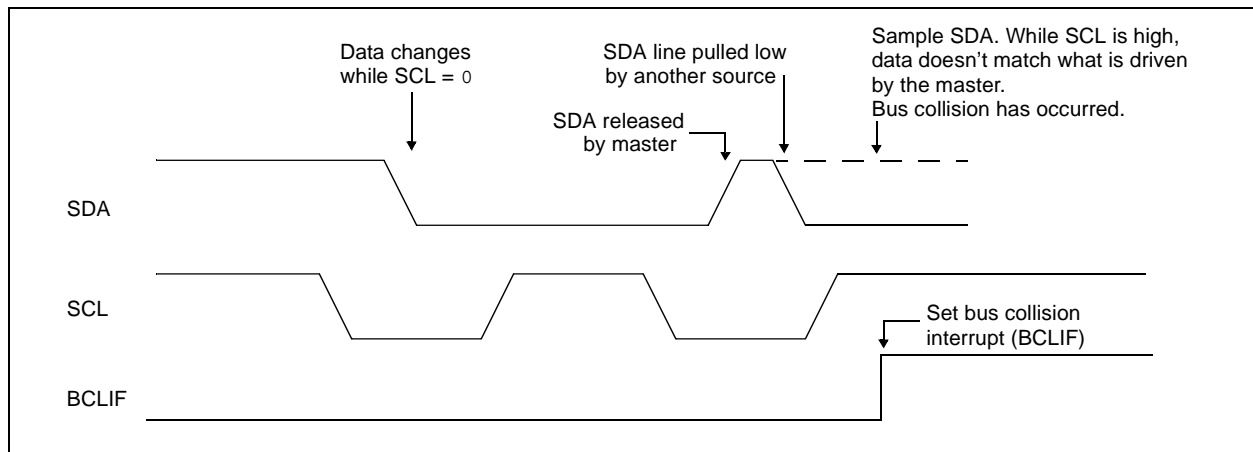

PIC18F6525/6621/8525/8621

18.4.17.1 Bus Collision During a Start Condition

During a Start condition, a bus collision occurs if:

- SDA or SCL are sampled low at the beginning of the Start condition (Figure 18-26).
- SCL is sampled low before SDA is asserted low (Figure 18-27).

During a Start condition, both the SDA and the SCL pins are monitored.

If the SDA pin is already low, or the SCL pin is already low, then all of the following occur:

- the Start condition is aborted,
- the BCLIF flag is set and
- the MSSP module is reset to its Idle state (Figure 18-26).

The Start condition begins with the SDA and SCL pins deasserted. When the SDA pin is sampled high, the Baud Rate Generator is loaded from SSPADD<6:0> and counts down to '0'. If the SCL pin is sampled low while SDA is high, a bus collision occurs because it is assumed that another master is attempting to drive a data '1' during the Start condition.

If the SDA pin is sampled low during this count, the BRG is reset and the SDA line is asserted early (Figure 18-28). If, however, a '1' is sampled on the SDA pin, the SDA pin is asserted low at the end of the BRG count. The Baud Rate Generator is then reloaded and counts down to '0' and during this time, if the SCL pin is sampled as '0', a bus collision does not occur. At the end of the BRG count, the SCL pin is asserted low.

Note: The reason that bus collision is not a factor during a Start condition is that no two bus masters can assert a Start condition at the exact same time. Therefore, one master will always assert SDA before the other. This condition does not cause a bus collision because the two masters must be allowed to arbitrate the first address following the Start condition. If the address is the same, arbitration must be allowed to continue into the data portion, Repeated Start or Stop conditions.

FIGURE 18-26: BUS COLLISION DURING START CONDITION (SDA ONLY)

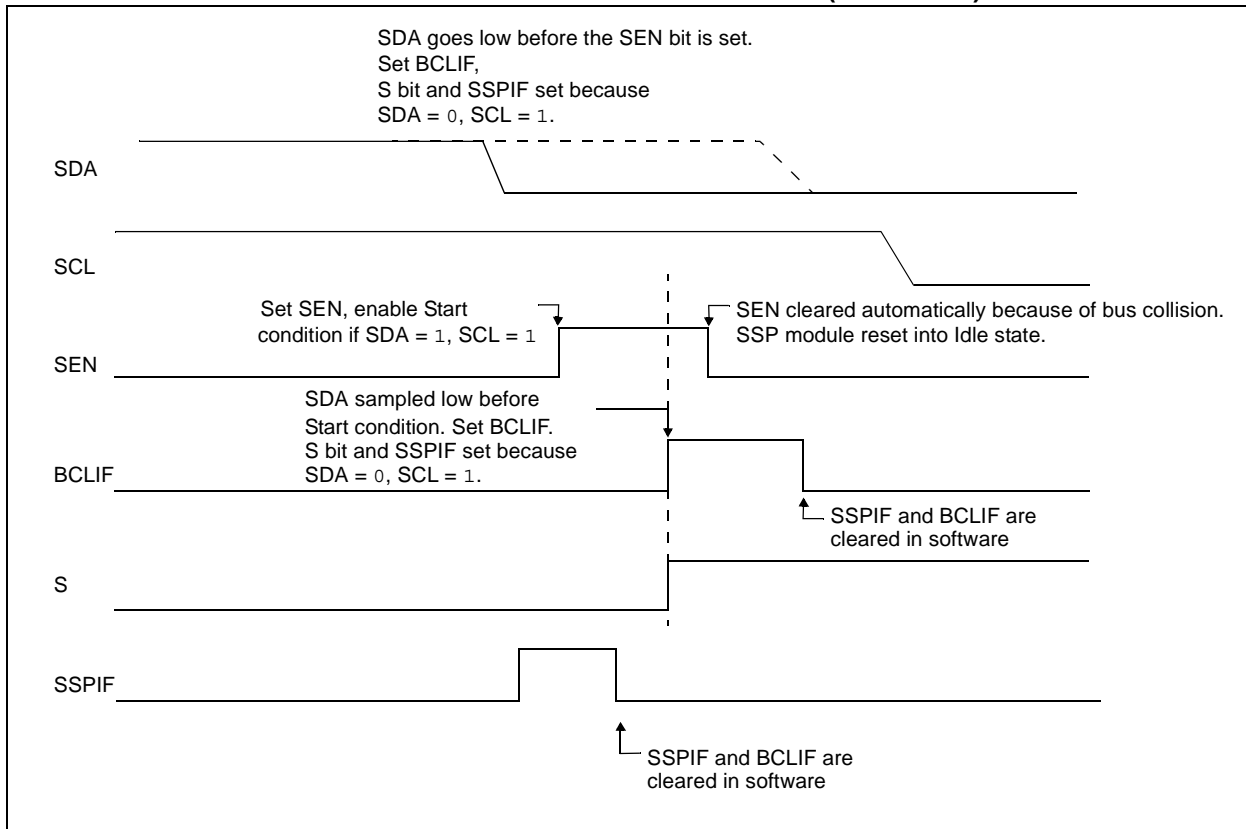

FIGURE 18-27: BUS COLLISION DURING START CONDITION (SCL = 0)

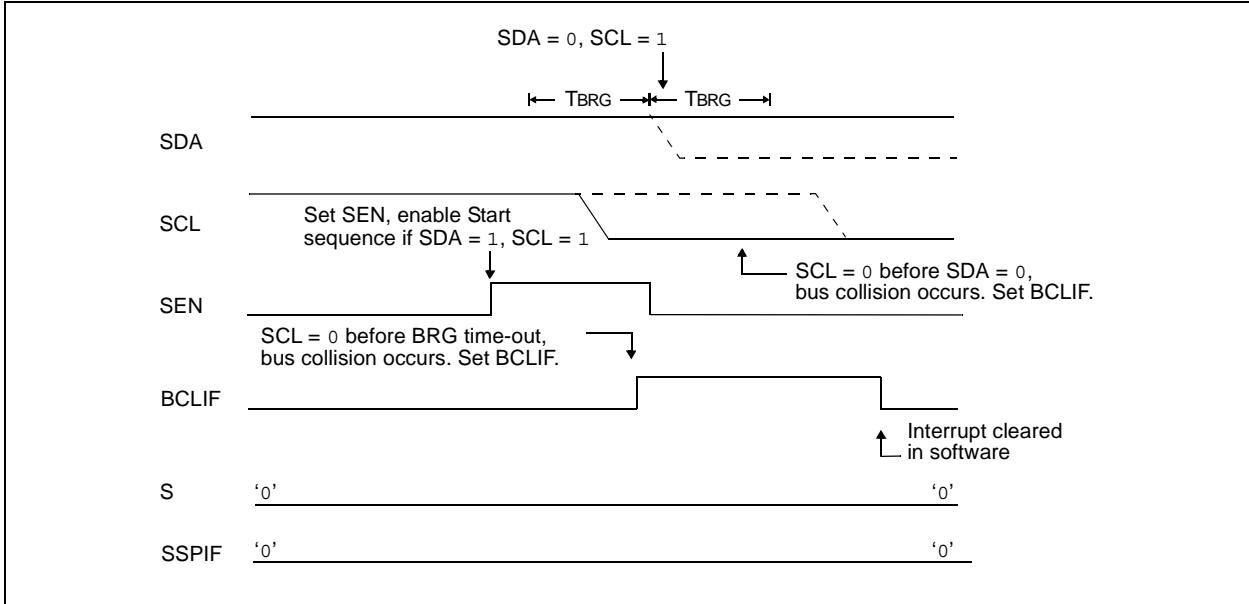
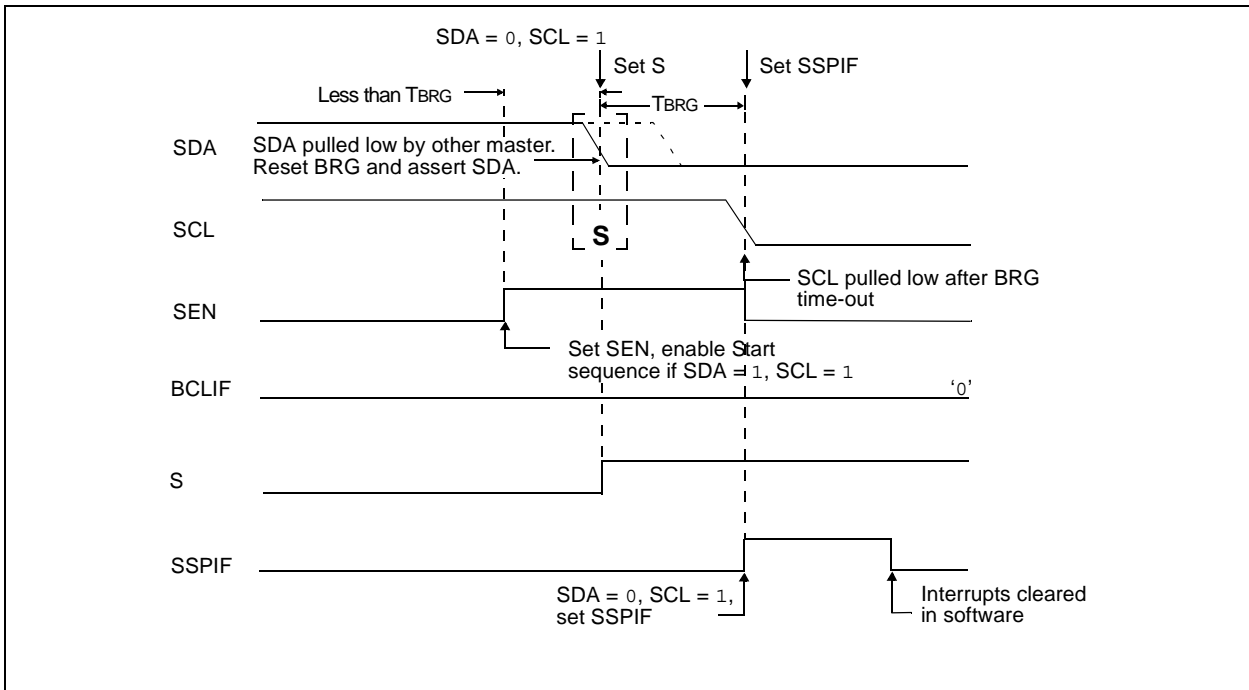

FIGURE 18-28: BRG RESET DUE TO SDA ARBITRATION DURING START CONDITION



PIC18F6525/6621/8525/8621

18.4.17.2 Bus Collision During a Repeated Start Condition

During a Repeated Start condition, a bus collision occurs if:

- A low level is sampled on SDA when SCL goes from low level to high level.
- SCL goes low before SDA is asserted low, indicating that another master is attempting to transmit a data '1'.

When the user deasserts SDA and the pin is allowed to float high, the BRG is loaded with SSPADD<6:0> and counts down to '0'. The SCL pin is then deasserted and when sampled high, the SDA pin is sampled.

If SDA is low, a bus collision has occurred (i.e., another master is attempting to transmit a data '0', Figure 18-29). If SDA is sampled high, the BRG is reloaded and begins counting. If SDA goes from high-to-low before the BRG times out, no bus collision occurs because no two masters can assert SDA at exactly the same time.

If SCL goes from high-to-low before the BRG times out and SDA has not already been asserted, a bus collision occurs. In this case, another master is attempting to transmit a data '1' during the Repeated Start condition, see Figure 18-30.

If, at the end of the BRG time-out, both SCL and SDA are still high, the SDA pin is driven low and the BRG is reloaded and begins counting. At the end of the count regardless of the status of the SCL pin, the SCL pin is driven low and the Repeated Start condition is complete.

FIGURE 18-29: BUS COLLISION DURING A REPEATED START CONDITION (CASE 1)

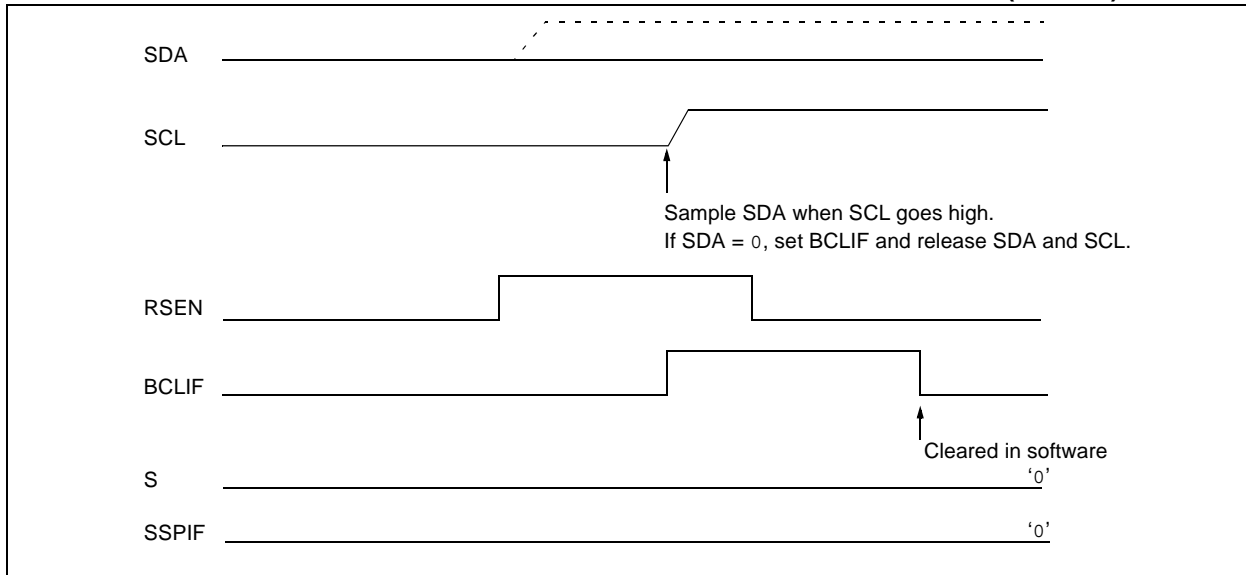
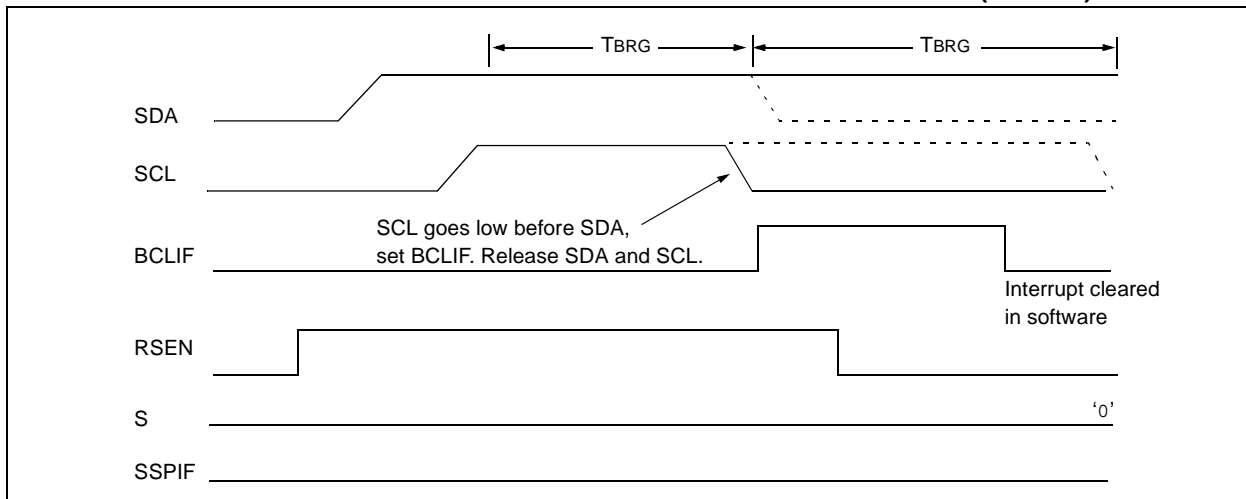

FIGURE 18-30: BUS COLLISION DURING REPEATED START CONDITION (CASE 2)



PIC18F6525/6621/8525/8621

18.4.17.3 Bus Collision During a Stop Condition

Bus collision occurs during a Stop condition if:

- After the SDA pin has been deasserted and allowed to float high, SDA is sampled low after the BRG has timed out.
- After the SCL pin is deasserted, SCL is sampled low before SDA goes high.

The Stop condition begins with SDA asserted low. When SDA is sampled low, the SCL pin is allowed to float. When the pin is sampled high (clock arbitration), the Baud Rate Generator is loaded with SSPADD<6:0> and counts down to '0'. After the BRG times out, SDA is sampled. If SDA is sampled low, a bus collision has occurred. This is due to another master attempting to drive a data '0' (Figure 18-31). If the SCL pin is sampled low before SDA is allowed to float high, a bus collision occurs. This is another case of another master attempting to drive a data '0' (Figure 18-32).

FIGURE 18-31: BUS COLLISION DURING A STOP CONDITION (CASE 1)

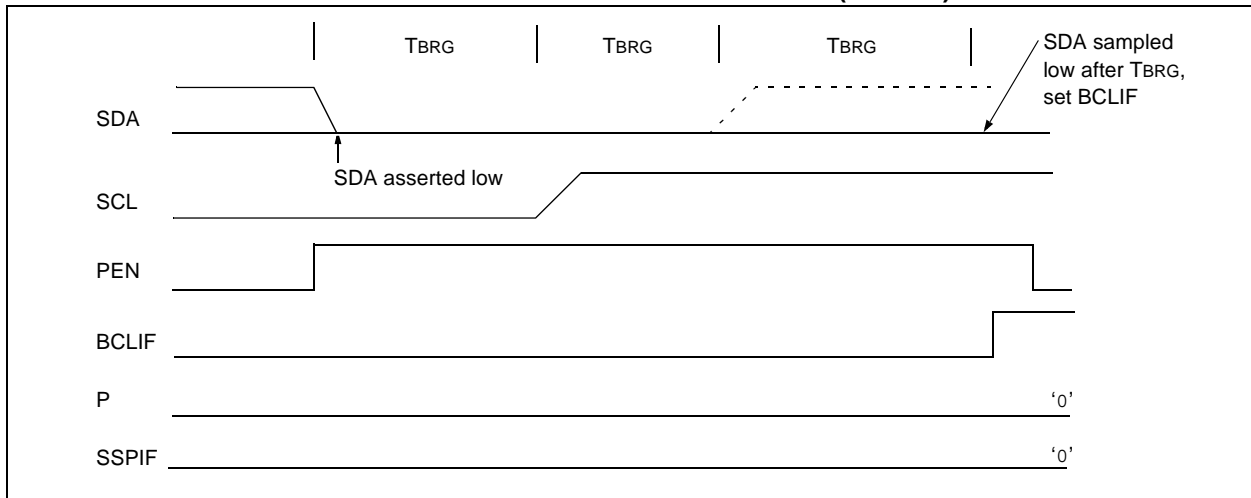
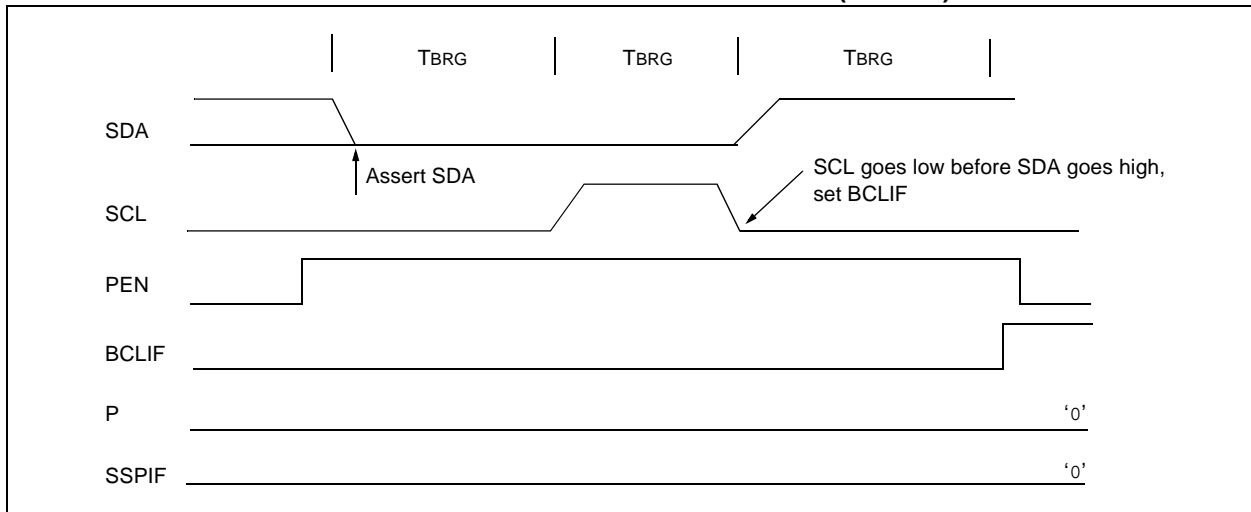

FIGURE 18-32: BUS COLLISION DURING A STOP CONDITION (CASE 2)



PIC18F6525/6621/8525/8621

TABLE 18-4: REGISTERS ASSOCIATED WITH I²C™ OPERATION

Name	Bit 7	Bit 6	Bit 5	Bit 4	Bit 3	Bit 2	Bit 1	Bit 0	Value on POR, BOR	Value on all other Resets
INTCON	GIE/GIEH	PEIE/GIEL	TMR0IE	INT0IE	RBIE	TMR0IF	INT0IF	RBIF	0000 000x	0000 000u
PIR1	PSPIF ⁽¹⁾	ADIF	RC1IF	TX1IF	SSPIF	CCP1IF	TMR2IF	TMR1IF	0000 0000	0000 0000
PIE1	PSPIE ⁽¹⁾	ADIE	RC1IE	TX1IE	SSPIE	CCP1IE	TMR2IE	TMR1IE	0000 0000	0000 0000
IPR1	PSPIP ⁽¹⁾	ADIP	RC1IP	TX1IP	SSPIP	CCP1IP	TMR2IP	TMR1IP	1111 1111	1111 1111
TRISC	PORTC Data Direction Register								1111 1111	1111 1111
TRISF	TRISF7	TRISF6	TRISF5	TRISF4	TRISF3	TRISF2	TRISF1	TRISF0	1111 1111	1111 1111
SSPBUF	MSSP Receive Buffer/Transmit Register								xxxx xxxx	uuuu uuuu
SSPADD	MSSP Address Register in I ² C Slave mode. MSSP Baud Rate Reload Register in I ² C Master mode.								0000 0000	0000 0000
SSPCON1	WCOL	SSPOV	SSPEN	CKP	SSPM3	SSPM2	SSPM1	SSPM0	0000 0000	0000 0000
SSPSTAT	SMP	CKE	D/Ā	P	S	R/W	UA	BF	0000 0000	0000 0000

Legend: x = unknown, u = unchanged, — = unimplemented, read as '0'. Shaded cells are not used by the MSSP in I²C™ mode.

Note 1: Enabled only in Microcontroller mode for PIC18F8525/8621 devices.

19.0 ENHANCED UNIVERSAL SYNCHRONOUS ASYNCHRONOUS RECEIVER TRANSMITTER (EUSART)

The Enhanced Universal Synchronous Asynchronous Receiver Transmitter (EUSART) module is one of the two serial I/O modules. (USART is also known as a Serial Communications Interface or SCI.) The EUSART can be configured as a full-duplex asynchronous system that can communicate with peripheral devices, such as CRT terminals and personal computers. It can also be configured as a half-duplex synchronous system that can communicate with peripheral devices, such as A/D or D/A integrated circuits, serial EEPROMs, etc.

The Enhanced USART module implements additional features, including automatic baud rate detection and calibration, automatic wake-up on Sync Break reception and 12-bit Break character transmit. These make it ideally suited for use in Local Interconnect Network bus (LIN bus) systems.

The EUSART can be configured in the following modes:

- Asynchronous (full duplex) with:
 - Auto-Wake-up on character reception
 - Auto-Baud calibration
 - 12-bit Break character transmission
- Synchronous – Master (half duplex) with selectable clock polarity
- Synchronous – Slave (half duplex) with selectable clock polarity

The pins of USART1 and USART2 are multiplexed with the functions of PORTC (RC6/TX1/CK1 and RC7/RX1/DT1) and PORTG (RG1/TX2/CK2 and RG2/RX2/DT2), respectively. In order to configure these pins as an EUSART:

- For USART1:
 - bit SPEN (RCSTA1<7>) must be set (= 1)
 - bit TRISC<7> must be set (= 1)
 - bit TRISC<6> must be cleared (= 0) for Asynchronous and Synchronous Master modes
 - bit TRISC<6> must be set (= 1) for Synchronous Slave mode
- For USART2:
 - bit SPEN (RCSTA2<7>) must be set (= 1)
 - bit TRISG<2> must be set (= 1)
 - bit TRISG<1> must be cleared (= 0) for Asynchronous and Synchronous Master modes
 - bit TRISC<6> must be set (= 1) for Synchronous Slave mode

Note: The EUSART control will automatically reconfigure the pin from input to output as needed.

The operation of each Enhanced USART module is controlled through three registers:

- Transmit Status and Control (TXSTAx)
- Receive Status and Control (RCSTAx)
- Baud Rate Control (BAUDCONx)

These are detailed on the following pages in Register 19-1, Register 19-2 and Register 19-3, respectively.

Note: Throughout this section, references to register and bit names that may be associated with a specific EUSART module are referred to generically by the use of 'x' in place of the specific module number. Thus, "RCSTAx" might refer to the Receive Status register for either USART1 or USART2

PIC18F6525/6621/8525/8621

REGISTER 19-1: TXSTAx: TRANSMIT STATUS AND CONTROL REGISTER

R/W-0	R/W-0	R/W-0	R/W-0	R/W-0	R/W-0	R-1	R/W-0
CSRC	TX9	TXEN	SYNC	SENDB	BRGH	TRMT	TX9D

bit 7

bit 0

bit 7 **CSRC:** Clock Source Select bit

Asynchronous mode:

Don't care.

Synchronous mode:

1 = Master mode (clock generated internally from BRG)

0 = Slave mode (clock from external source)

bit 6 **TX9:** 9-bit Transmit Enable bit

1 = Selects 9-bit transmission

0 = Selects 8-bit transmission

bit 5 **TXEN:** Transmit Enable bit

1 = Transmit enabled

0 = Transmit disabled

Note: SREN/CREN overrides TXEN in Sync mode.

bit 4 **SYNC:** EUSART Mode Select bit

1 = Synchronous mode

0 = Asynchronous mode

bit 3 **SENDB:** Send Break Character bit

Asynchronous mode:

1 = Send sync break on next transmission (cleared by hardware upon completion)

0 = Sync break transmission completed

Synchronous mode:

Don't care.

bit 2 **BRGH:** High Baud Rate Select bit

Asynchronous mode:

1 = High speed

0 = Low speed

Synchronous mode:

Unused in this mode.

bit 1 **TRMT:** Transmit Shift Register Status bit

1 = TSR empty

0 = TSR full

bit 0 **TX9D:** 9th bit of Transmit Data

Can be address/data bit or a parity bit.

Legend:

R = Readable bit

W = Writable bit

U = Unimplemented bit, read as '0'

-n = Value at POR

'1' = Bit is set

'0' = Bit is cleared

x = Bit is unknown

PIC18F6525/6621/8525/8621

REGISTER 19-2: RCSTAx: RECEIVE STATUS AND CONTROL REGISTER

R/W-0	R/W-0	R/W-0	R/W-0	R/W-0	R-0	R-0	R-x
SPEN	RX9	SREN	CREN	ADDEN	FERR	OERR	RX9D
bit 7							bit 0

- bit 7 **SPEN:** Serial Port Enable bit
 1 = Serial port enabled (configures RXx/DTx and TXx/CKx pins as serial port pins)
 0 = Serial port disabled (held in Reset)
- bit 6 **RX9:** 9-bit Receive Enable bit
 1 = Selects 9-bit reception
 0 = Selects 8-bit reception
- bit 5 **SREN:** Single Receive Enable bit
Asynchronous mode:
 Don't care.
Synchronous mode – Master:
 1 = Enables single receive
 0 = Disables single receive
 This bit is cleared after reception is complete.
Synchronous mode – Slave:
 Don't care.
- bit 4 **CREN:** Continuous Receive Enable bit
Asynchronous mode:
 1 = Enables receiver
 0 = Disables receiver
Synchronous mode:
 1 = Enables continuous receive until enable bit CREN is cleared (CREN overrides SREN)
 0 = Disables continuous receive
- bit 3 **ADDEN:** Address Detect Enable bit
Asynchronous mode 9-bit (RX9 = 1):
 1 = Enables address detection, enables interrupt and loads the receive buffer when RSR<8> is set
 0 = Disables address detection, all bytes are received and ninth bit can be used as parity bit
Asynchronous mode 9-bit (RX9 = 0):
 Don't care.
- bit 2 **FERR:** Framing Error bit
 1 = Framing error (can be updated by reading RCREGx register and receive next valid byte)
 0 = No framing error
- bit 1 **OERR:** Overrun Error bit
 1 = Overrun error (can be cleared by clearing bit CREN)
 0 = No overrun error
- bit 0 **RX9D:** 9th bit of Received Data
 This can be address/data bit or a parity bit and must be calculated by user firmware.

Legend:

R = Readable bit	W = Writable bit	U = Unimplemented bit, read as '0'
-n = Value at POR	'1' = Bit is set	'0' = Bit is cleared x = Bit is unknown

PIC18F6525/6621/8525/8621

REGISTER 19-3: BAUDCONx: BAUD RATE CONTROL REGISTER

U-0	R-1	U-0	R/W-0	R/W-0	U-0	R/W-0	R/W-0
—	RCIDL	—	SCKP	BRG16	—	WUE	ABDEN
bit 7							bit 0

- bit 7 **Unimplemented:** Read as '0'
- bit 6 **RCIDL:** Receive Operation Idle Status bit
 1 = Receive operation is Idle
 0 = Receive operation is active
- bit 5 **Unimplemented:** Read as '0'
- bit 4 **SCKP:** Synchronous Clock Polarity Select bit
Asynchronous mode:
 Unused in this mode.
Synchronous mode:
 1 = Idle state for clock (CKx) is a high level
 0 = Idle state for clock (CKx) is a low level
- bit 3 **BRG16:** 16-bit Baud Rate Register Enable bit
 1 = 16-bit Baud Rate Generator – SPBRGHx and SPBRGx
 0 = 8-bit Baud Rate Generator – SPBRGx only (Compatible mode), SPBRGHx value ignored
- bit 2 **Unimplemented:** Read as '0'
- bit 1 **WUE:** Wake-up Enable bit
Asynchronous mode:
 1 = EUSART will continue to sample the RXx pin – interrupt generated on falling edge; bit cleared in hardware on following rising edge
 0 = RXx pin not monitored or rising edge detected
Synchronous mode:
 Unused in this mode.
- bit 0 **ABDEN:** Auto-Baud Rate Detect Enable bit
Asynchronous mode:
 1 = Enable baud rate measurement on the next character – requires reception of a Sync field (55h); cleared in hardware upon completion
 0 = Baud rate measurement disabled or completed
Synchronous mode:
 Unused in this mode.

Legend:

R = Readable bit	W = Writable bit	U = Unimplemented bit, read as '0'
-n = Value at POR	'1' = Bit is set	'0' = Bit is cleared x = Bit is unknown

PIC18F6525/6621/8525/8621

19.1 EUSART Baud Rate Generator (BRG)

The BRG is a dedicated 8-bit or 16-bit generator that supports both the Asynchronous and Synchronous modes of the EUSART. By default, the BRG operates in 8-bit mode; setting the BRG16 bit (BAUDCONx<3>) selects 16-bit mode.

The SPBRGHx:SPBRGx register pair controls the period of a free running timer. In Asynchronous mode, bits BRGH (TXSTAx<2>) and BRG16 also control the baud rate. In Synchronous mode, bit BRGH is ignored. Table 19-1 shows the formula for computation of the baud rate for different EUSART modes which only apply in Master mode (internally generated clock).

Given the desired baud rate and FOSC, the nearest integer value for the SPBRGHx:SPBRGx registers can be calculated using the formulas in Table 19-1. From

this, the error in baud rate can be determined. An example calculation is shown in Example 19-1. Typical baud rates and error values for the various Asynchronous modes are shown in Table 19-2. It may be advantageous to use the high baud rate (BRGH = 1) or the 16-bit BRG to reduce the baud rate error, or achieve a slow baud rate for a fast oscillator frequency.

Writing a new value to the SPBRGHx:SPBRGx registers causes the BRG timer to be reset (or cleared). This ensures the BRG does not wait for a timer overflow before outputting the new baud rate.

19.1.1 SAMPLING

The data on the RXx pin (either RC7/RX1/DT1 or RG2/RX2/DT2) is sampled three times by a majority detect circuit to determine if a high or a low level is present at the RXx pin.

TABLE 19-1: BAUD RATE FORMULAS

Configuration Bits			BRG/EUSART Mode	Baud Rate Formula
SYNC	BRG16	BRGH		
0	0	0	8-bit/Asynchronous	$F_{osc}/[64 (n + 1)]$
0	0	1	8-bit/Asynchronous	$F_{osc}/[16 (n + 1)]$
0	1	0	16-bit/Asynchronous	
0	1	1	16-bit/Asynchronous	$F_{osc}/[4 (n + 1)]$
1	0	x	8-bit/Synchronous	
1	1	x	16-bit/Synchronous	

Legend: x = Don't care, n = value of SPBRGHx:SPBRGx register pair

EXAMPLE 19-1: CALCULATING BAUD RATE ERROR

For a device with FOSC of 16 MHz, desired baud rate of 9600, Asynchronous mode, 8-bit BRG:

Desired Baud Rate = $F_{osc}/(64 ([SPBRGHx:SPBRGx] + 1))$

Solving for SPBRGHx:SPBRGx:

$$\begin{aligned} X &= ((F_{osc}/\text{Desired Baud Rate})/64) - 1 \\ &= ((16000000/9600)/64) - 1 \\ &= [25.042] = 25 \end{aligned}$$

Calculated Baud Rate = $16000000/(64 (25 + 1))$

$$= 9615$$

Error = $(\text{Calculated Baud Rate} - \text{Desired Baud Rate})/\text{Desired Baud Rate}$

$$= (9615 - 9600)/9600 = 0.16\%$$

TABLE 19-2: REGISTERS ASSOCIATED WITH BAUD RATE GENERATOR

Name	Bit 7	Bit 6	Bit 5	Bit 4	Bit 3	Bit 2	Bit 1	Bit 0	Value on POR, BOR	Value on all other Resets
TXSTAx	CSRC	TX9	TXEN	SYNC	SENDB	BRGH	TRMT	TX9D	0000 0010	0000 0010
RCSTAx	SPEN	RX9	SREN	CREN	ADDEN	FERR	OERR	RX9D	0000 000x	0000 000x
BAUDCONx	—	RCIDL	—	SCKP	BRG16	—	WUE	ABDEN	-1-0 0-00	-1-0 0-00
SPBRGHx	Enhanced USARTx Baud Rate Generator Register High Byte								0000 0000	0000 0000
SPBRGx	Enhanced USARTx Baud Rate Generator Register Low Byte								0000 0000	0000 0000

Legend: x = unknown, — = unimplemented, read as '0'. Shaded cells are not used by the BRG.

PIC18F6525/6621/8525/8621

TABLE 19-3: BAUD RATES FOR ASYNCHRONOUS MODES

BAUD RATE (K)	SYNC = 0, BRGH = 0, BRG16 = 0											
	Fosc = 40.000 MHz			Fosc = 20.000 MHz			Fosc = 10.000 MHz			Fosc = 8.000 MHz		
	Actual Rate (K)	% Error	SPBRG value (decimal)	Actual Rate (K)	% Error	SPBRG value (decimal)	Actual Rate (K)	% Error	SPBRG value (decimal)	Actual Rate (K)	% Error	SPBRG value (decimal)
0.3	—	—	—	—	—	—	—	—	—	—	—	—
1.2	—	—	—	1.221	1.73	255	1.202	0.16	129	1201	-0.16	103
2.4	2.441	1.73	255	2.404	0.16	129	2.404	0.16	64	2403	-0.16	51
9.6	9.615	0.16	64	9.766	1.73	31	9.766	1.73	15	9615	-0.16	12
19.2	19.531	1.73	31	19.531	1.73	15	19.531	1.73	7	—	—	—
57.6	56.818	-1.36	10	62.500	8.51	4	52.083	-9.58	2	—	—	—
115.2	125.000	8.51	4	104.167	-9.58	2	78.125	-32.18	1	—	—	—

BAUD RATE (K)	SYNC = 0, BRGH = 0, BRG16 = 0								
	Fosc = 4.000 MHz			Fosc = 2.000 MHz			Fosc = 1.000 MHz		
	Actual Rate (K)	% Error	SPBRG value (decimal)	Actual Rate (K)	% Error	SPBRG value (decimal)	Actual Rate (K)	% Error	SPBRG value (decimal)
0.3	0.300	0.16	207	300	-0.16	103	300	-0.16	51
1.2	1.202	0.16	51	1201	-0.16	25	1201	-0.16	12
2.4	2.404	0.16	25	2403	-0.16	12	—	—	—
9.6	8.929	-6.99	6	—	—	—	—	—	—
19.2	20.833	8.51	2	—	—	—	—	—	—
57.6	62.500	8.51	0	—	—	—	—	—	—
115.2	62.500	-45.75	0	—	—	—	—	—	—

BAUD RATE (K)	SYNC = 0, BRGH = 1, BRG16 = 0											
	Fosc = 40.000 MHz			Fosc = 20.000 MHz			Fosc = 10.000 MHz			Fosc = 8.000 MHz		
	Actual Rate (K)	% Error	SPBRG value (decimal)	Actual Rate (K)	% Error	SPBRG value (decimal)	Actual Rate (K)	% Error	SPBRG value (decimal)	Actual Rate (K)	% Error	SPBRG value (decimal)
0.3	—	—	—	—	—	—	—	—	—	—	—	—
1.2	—	—	—	—	—	—	—	—	—	—	—	—
2.4	—	—	—	—	—	—	2.441	1.73	255	2403	-0.16	207
9.6	9.766	1.73	255	9.615	0.16	129	9.615	0.16	64	9615	-0.16	51
19.2	19.231	0.16	129	19.231	0.16	64	19.531	1.73	31	19230	-0.16	25
57.6	58.140	0.94	42	56.818	-1.36	21	56.818	-1.36	10	55555	3.55	8
115.2	113.636	-1.36	21	113.636	-1.36	10	125.000	8.51	4	—	—	—

BAUD RATE (K)	SYNC = 0, BRGH = 1, BRG16 = 0								
	Fosc = 4.000 MHz			Fosc = 2.000 MHz			Fosc = 1.000 MHz		
	Actual Rate (K)	% Error	SPBRG value (decimal)	Actual Rate (K)	% Error	SPBRG value (decimal)	Actual Rate (K)	% Error	SPBRG value (decimal)
0.3	—	—	—	—	—	—	300	-0.16	207
1.2	1.202	0.16	207	1201	-0.16	103	1201	-0.16	51
2.4	2.404	0.16	103	2403	-0.16	51	2403	-0.16	25
9.6	9.615	0.16	25	9615	-0.16	12	—	—	—
19.2	19.231	0.16	12	—	—	—	—	—	—
57.6	62.500	8.51	3	—	—	—	—	—	—
115.2	125.000	8.51	1	—	—	—	—	—	—

PIC18F6525/6621/8525/8621

TABLE 19-3: BAUD RATES FOR ASYNCHRONOUS MODES (CONTINUED)

BAUD RATE (K)	SYNC = 0, BRGH = 0, BRG16 = 1											
	Fosc = 40.000 MHz			Fosc = 20.000 MHz			Fosc = 10.000 MHz			Fosc = 8.000 MHz		
	Actual Rate (K)	% Error	SPBRG value (decimal)	Actual Rate (K)	% Error	SPBRG value (decimal)	Actual Rate (K)	% Error	SPBRG value (decimal)	Actual Rate (K)	% Error	SPBRG value (decimal)
0.3	0.300	0.00	8332	0.300	0.02	4165	0.300	0.02	2082	300	-0.04	1665
1.2	1.200	0.02	2082	1.200	-0.03	1041	1.200	-0.03	520	1201	-0.16	415
2.4	2.402	0.06	1040	2.399	-0.03	520	2.404	0.16	259	2403	-0.16	207
9.6	9.615	0.16	259	9.615	0.16	129	9.615	0.16	64	9615	-0.16	51
19.2	19.231	0.16	129	19.231	0.16	64	19.531	1.73	31	19230	-0.16	25
57.6	58.140	0.94	42	56.818	-1.36	21	56.818	-1.36	10	55555	3.55	8
115.2	113.636	-1.36	21	113.636	-1.36	10	125.000	8.51	4	—	—	—

BAUD RATE (K)	SYNC = 0, BRGH = 0, BRG16 = 1								
	Fosc = 4.000 MHz			Fosc = 2.000 MHz			Fosc = 1.000 MHz		
	Actual Rate (K)	% Error	SPBRG value (decimal)	Actual Rate (K)	% Error	SPBRG value (decimal)	Actual Rate (K)	% Error	SPBRG value (decimal)
0.3	0.300	0.04	832	300	-0.16	415	300	-0.16	207
1.2	1.202	0.16	207	1201	-0.16	103	1201	-0.16	51
2.4	2.404	0.16	103	2403	-0.16	51	2403	-0.16	25
9.6	9.615	0.16	25	9615	-0.16	12	—	—	—
19.2	19.231	0.16	12	—	—	—	—	—	—
57.6	62.500	8.51	3	—	—	—	—	—	—
115.2	125.000	8.51	1	—	—	—	—	—	—

BAUD RATE (K)	SYNC = 0, BRGH = 1, BRG16 = 1 or SYNC = 1, BRG16 = 1											
	Fosc = 40.000 MHz			Fosc = 20.000 MHz			Fosc = 10.000 MHz			Fosc = 8.000 MHz		
	Actual Rate (K)	% Error	SPBRG value (decimal)	Actual Rate (K)	% Error	SPBRG value (decimal)	Actual Rate (K)	% Error	SPBRG value (decimal)	Actual Rate (K)	% Error	SPBRG value (decimal)
0.3	0.300	0.00	33332	0.300	0.00	16665	0.300	0.00	8332	300	-0.01	6665
1.2	1.200	0.00	8332	1.200	0.02	4165	1.200	0.02	2082	1200	-0.04	1665
2.4	2.400	0.02	4165	2.400	0.02	2082	2.402	0.06	1040	2400	-0.04	832
9.6	9.606	0.06	1040	9.596	-0.03	520	9.615	0.16	259	9615	-0.16	207
19.2	19.193	-0.03	520	19.231	0.16	259	19.231	0.16	129	19230	-0.16	103
57.6	57.803	0.35	172	57.471	-0.22	86	58.140	0.94	42	57142	0.79	34
115.2	114.943	-0.22	86	116.279	0.94	42	113.636	-1.36	21	117647	-2.12	16

BAUD RATE (K)	SYNC = 0, BRGH = 1, BRG16 = 1 or SYNC = 1, BRG16 = 1								
	Fosc = 4.000 MHz			Fosc = 2.000 MHz			Fosc = 1.000 MHz		
	Actual Rate (K)	% Error	SPBRG value (decimal)	Actual Rate (K)	% Error	SPBRG value (decimal)	Actual Rate (K)	% Error	SPBRG value (decimal)
0.3	0.300	0.01	3332	300	-0.04	1665	300	-0.04	832
1.2	1.200	0.04	832	1201	-0.16	415	1201	-0.16	207
2.4	2.404	0.16	415	2403	-0.16	207	2403	-0.16	103
9.6	9.615	0.16	103	9615	-0.16	51	9615	-0.16	25
19.2	19.231	0.16	51	19230	-0.16	25	19230	-0.16	12
57.6	58.824	2.12	16	55555	3.55	8	—	—	—
115.2	111.111	-3.55	8	—	—	—	—	—	—

PIC18F6525/6621/8525/8621

19.1.2 AUTO-BAUD RATE DETECT

The Enhanced USART module supports the automatic detection and calibration of baud rate. This feature is active only in Asynchronous mode and while the WUE bit is clear.

The automatic baud rate measurement sequence (Figure 19-1) begins whenever a Start bit is received and the ABDEN bit is set. The calculation is self-averaging.

In the Auto-Baud Rate Detect (ABD) mode, the clock to the BRG is reversed. Rather than the BRG clocking the incoming RXx signal, the RXx signal is timing the BRG. In ABD mode, the internal Baud Rate Generator is used as a counter to time the bit period of the incoming serial byte stream.

Once the ABDEN bit is set, the state machine will clear the BRG and look for a Start bit. The Auto-Baud Rate Detect must receive a byte with the value 55h (ASCII "U", which is also the LIN bus Sync character), in order to calculate the proper bit rate. The measurement is taken over both a low and a high bit time in order to minimize any effects caused by asymmetry of the incoming signal. After a Start bit, the SPBRGx begins counting up using the preselected clock source on the first rising edge of RXx. After eight bits on the RXx pin or the fifth rising edge, an accumulated value totalling the proper BRG period is left in the SPBRGHx:SPBRGx register pair. Once the 5th edge is seen (this should correspond to the Stop bit), the ABDEN bit is automatically cleared.

While calibrating the baud rate period, the BRG registers are clocked at 1/8th the preconfigured clock rate. Note that the BRG clock will be configured by the BRG16 and BRGH bits. Independent of the BRG16 bit setting, both the SPBRGx and SPBRGHx will be used

as a 16-bit counter. This allows the user to verify that no carry occurred for 8-bit modes by checking for 00h in the SPBRGHx register. Refer to Table 19-4 for counter clock rates to the BRG.

While the ABD sequence takes place, the EUSART state machine is held in Idle. The RCxIF interrupt is set once the fifth rising edge on RXx is detected. The value in the RCREGx needs to be read to clear the RC1IF interrupt. RCREGx content should be discarded.

- Note 1:** If the WUE bit is set with the ABDEN bit, Auto-Baud Rate Detection will occur on the byte *following* the Break character.
- 2:** It is up to the user to determine that the incoming character baud rate is within the range of the selected BRG clock source. Some combinations of oscillator frequency and EUSART baud rates are not possible due to bit error rates. Overall system timing and communication baud rates must be taken into consideration when using the Auto-Baud Rate Detection feature.

TABLE 19-4: BRG COUNTER CLOCK RATES

BRG16	BRGH	BRG Counter Clock
0	0	Fosc/512
0	1	Fosc/128
1	0	Fosc/128
1	1	Fosc/32

Note: During the ABD sequence, SPBRGx and SPBRGHx are both used as a 16-bit counter, independent of BRG16 setting.

FIGURE 19-1: AUTOMATIC BAUD RATE CALCULATION

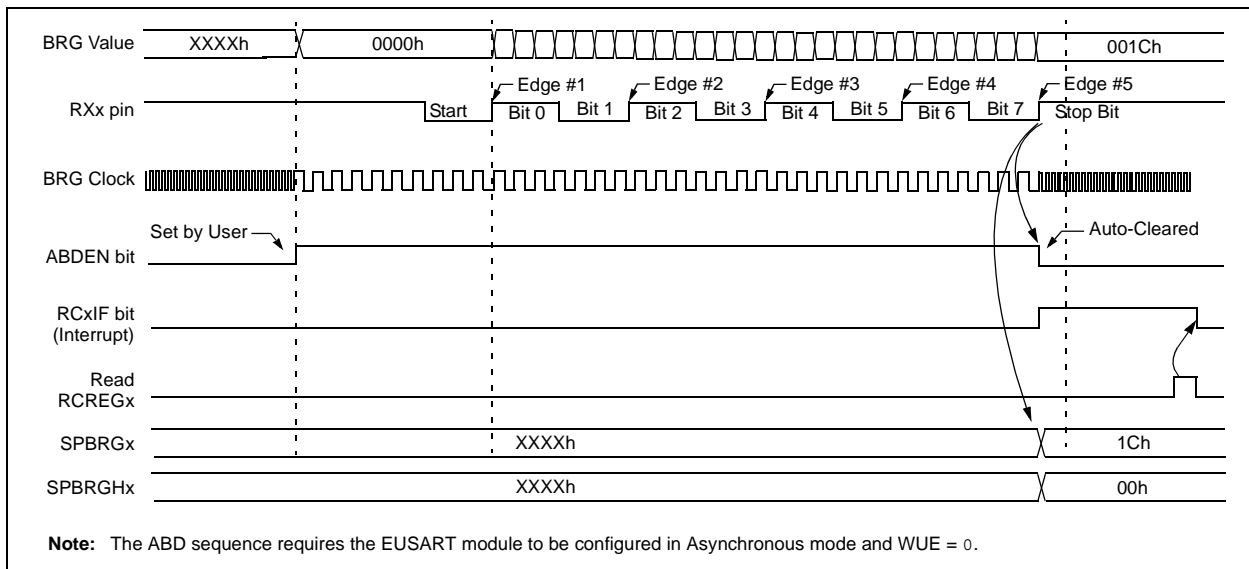

19.2 EUSART Asynchronous Mode

The Asynchronous mode of operation is selected by clearing the SYNC bit (TXSTAx<4>). In this mode, the EUSART uses standard non-return-to-zero (NRZ) format (one Start bit, eight or nine data bits and one Stop bit). The most common data format is 8 bits. An on-chip dedicated 8-bit/16-bit Baud Rate Generator can be used to derive standard baud rate frequencies from the oscillator.

The EUSART transmits and receives the LSb first. The EUSART module's transmitter and receiver are functionally independent but use the same data format and baud rate. The Baud Rate Generator produces a clock, either x16 or x64 of the bit shift rate depending on the BRGH and BRG16 bits (TXSTAx<2> and BAUDCONx<3>). Parity is not supported by the hardware but can be implemented in software and stored as the 9th data bit.

When operating in Asynchronous mode, the EUSART module consists of the following important elements:

- Baud Rate Generator
- Sampling Circuit
- Asynchronous Transmitter
- Asynchronous Receiver
- Auto-Wake-up on Sync Break Character
- 12-bit Break Character Transmit
- Auto-Baud Rate Detection

19.2.1 EUSART ASYNCHRONOUS TRANSMITTER

The EUSART transmitter block diagram is shown in Figure 19-2. The heart of the transmitter is the Transmit (Serial) Shift Register (TSR). The Shift register obtains its data from the Read/Write Transmit Buffer register, TXREGx. The TXREGx register is loaded with data in software. The TSR register is not loaded until the Stop bit has been transmitted from the previous load. As soon as the Stop bit is transmitted, the TSR is loaded with new data from the TXREGx register (if available).

Once the TXREGx register transfers the data to the TSR register (occurs in one Tcy), the TXREGx register is empty and flag bit TXxIF is set. This interrupt can be enabled/disabled by setting/clearing enable bit TXxIE. Flag bit TXxIF will be set regardless of the state of enable bit TXxIE and cannot be cleared in software. Flag bit TXxIF is not cleared immediately upon loading the Transmit Buffer register, TXREGx. TXxIF becomes valid in the second instruction cycle following the load instruction. Polling TXxIF immediately following a load of TXREGx will return invalid results.

While flag bit TXxIF indicates the status of the TXREGx register, another bit, TRMT (TXSTAx<1>), shows the status of the TSR register. Status bit TRMT is a read-only bit which is set when the TSR register is empty. No interrupt logic is tied to this bit so the user has to poll this bit in order to determine if the TSR register is empty.

Note 1: The TSR register is not mapped in data memory so it is not available to the user.

2: Flag bit TXxIF is set when enable bit TXEN is set.

To set up an Asynchronous Transmission:

1. Initialize the SPBRGHx:SPBRGx registers for the appropriate baud rate. Set or clear the BRGH and BRG16 bits, as required, to achieve the desired baud rate.
2. Enable the asynchronous serial port by clearing bit SYNC and setting bit SPEN.
3. If interrupts are desired, set enable bit TXxIE.
4. If 9-bit transmission is desired, set transmit bit TX9. Can be used as address/data bit.
5. Enable the transmission by setting bit TXEN which will also set bit TXxIF.
6. If 9-bit transmission is selected, the ninth bit should be loaded in bit TX9D.
7. Load data to the TXREGx register (starts transmission).

If using interrupts, ensure that the GIE and PEIE bits in the INTCON register (INTCON<7:6>) are set.

FIGURE 19-2: EUSART TRANSMIT BLOCK DIAGRAM

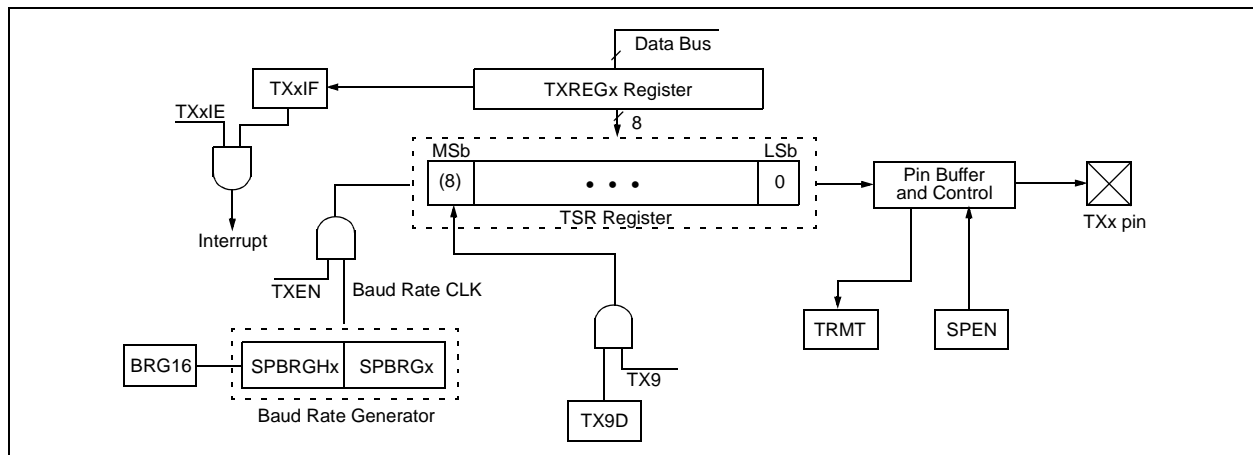

PIC18F6525/6621/8525/8621

FIGURE 19-3: ASYNCHRONOUS TRANSMISSION

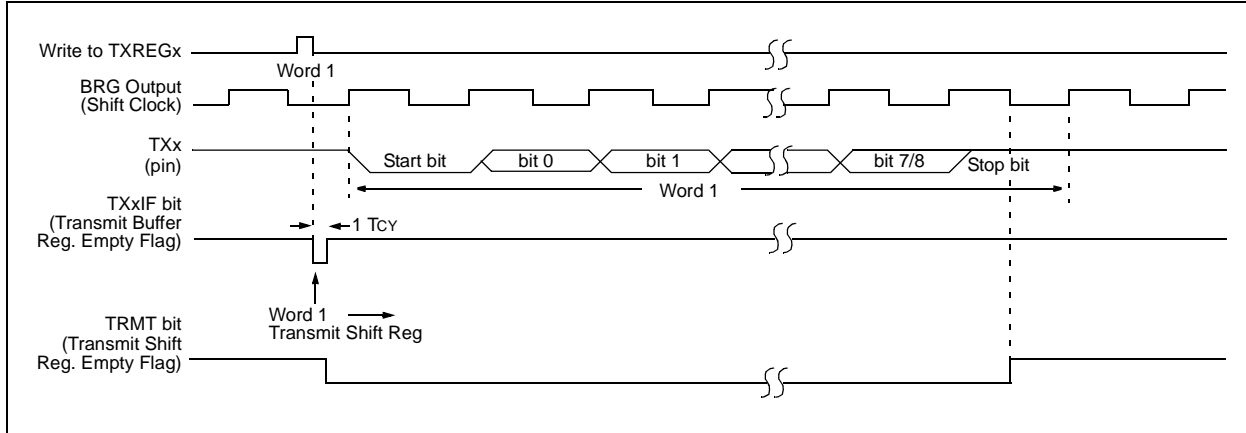

FIGURE 19-4: ASYNCHRONOUS TRANSMISSION (BACK TO BACK)

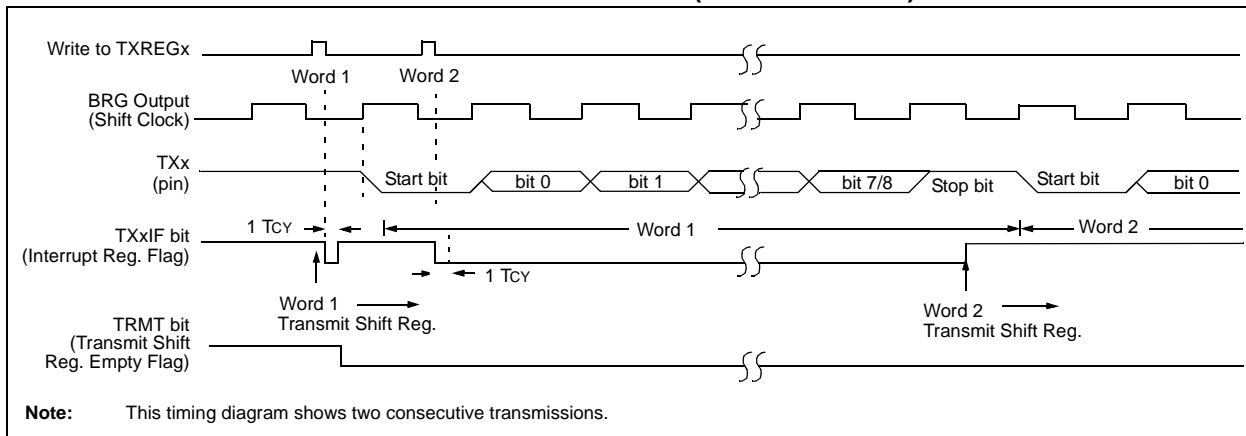

TABLE 19-5: REGISTERS ASSOCIATED WITH ASYNCHRONOUS TRANSMISSION

Name	Bit 7	Bit 6	Bit 5	Bit 4	Bit 3	Bit 2	Bit 1	Bit 0	Value on POR, BOR	Value on all other Resets
INTCON	GIE/GIEH	PEIE/GIEL	TMR0IE	INT0IE	RBIE	TMR0IF	INT0IF	RBF	0000 000x	0000 000u
PIR1	PSPIF ⁽¹⁾	ADIF	RC1IF	TX1IF	SSPIF	CCP1IF	TMR2IF	TMR1IF	0000 0000	0000 0000
PIE1	PSPIE ⁽¹⁾	ADIE	RC1IE	TX1IE	SSPIE	CCP1IE	TMR2IE	TMR1IE	0000 0000	0000 0000
IPR1	PSPIP ⁽¹⁾	ADIP	RC1IP	TX1IP	SSPIP	CCP1IP	TMR2IP	TMR1IP	1111 1111	1111 1111
PIR3	—	—	RC2IF	TX2IF	TMR4IF	CCP5IF	CCP4IF	CCP3IF	--00 0000	--00 0000
PIE3	—	—	RC2IE	TX2IE	TMR4IE	CCP5IE	CCP4IE	CCP3IE	--00 0000	--00 0000
IPR3	—	—	RC2IP	TX2IP	TMR4IP	CCP5IP	CCP4IP	CCP3IP	--11 1111	--11 1111
RCSTAx	SPEN	RX9	SREN	CREN	ADDEN	FERR	OERR	RX9D	0000 000x	0000 000x
TXREGx	Enhanced USARTx Transmit Register								0000 0000	0000 0000
TXSTAx	CSRC	TX9	TXEN	SYNC	SENDB	BRGH	TRMT	TX9D	0000 0010	0000 0010
BAUDCONx	—	RCIDL	—	SCKP	BRG16	—	WUE	ABDEN	-1-0 0-00	-1-0 0-00
SPBRGHx	Enhanced USARTx Baud Rate Generator Register High Byte								0000 0000	0000 0000
SPBRGx	Enhanced USARTx Baud Rate Generator Register Low Byte								0000 0000	0000 0000

Legend: x = unknown, - = unimplemented locations read as '0'. Shaded cells are not used for asynchronous transmission.

Note 1: Enabled only in Microcontroller mode for PIC18F8525/8621 devices.

19.2.2 EUSART ASYNCHRONOUS RECEIVER

The receiver block diagram is shown in Figure 19-5. The data is received on the RXx pin and drives the data recovery block. The data recovery block is actually a high speed shifter operating at x16 times the baud rate, whereas the main receive serial shifter operates at the bit rate or at Fosc. This mode would typically be used in RS-232 systems.

To set up an Asynchronous Reception:

1. Initialize the SPBRGHx:SPBRGx registers for the appropriate baud rate. Set or clear the BRGH and BRG16 bits, as required, to achieve the desired baud rate.
2. Enable the asynchronous serial port by clearing bit SYNC and setting bit SPEN.
3. If interrupts are desired, set enable bit RCxIE.
4. If 9-bit reception is desired, set bit RX9.
5. Enable the reception by setting bit CREN.
6. Flag bit RCxIF will be set when reception is complete and an interrupt will be generated if enable bit RCxIE was set.
7. Read the RCSTAx register to get the 9th bit (if enabled) and determine if any error occurred during reception.
8. Read the 8-bit received data by reading the RCREGx register.
9. If any error occurred, clear the error by clearing enable bit CREN.
10. If using interrupts, ensure that the GIE and PEIE bits in the INTCON register (INTCON<7:6>) are set.

19.2.3 SETTING UP 9-BIT MODE WITH ADDRESS DETECT

This mode would typically be used in RS-485 systems. To set up an Asynchronous Reception with Address Detect Enable:

1. Initialize the SPBRGHx:SPBRGx registers for the appropriate baud rate. Set or clear the BRGH and BRG16 bits, as required, to achieve the desired baud rate.
2. Enable the asynchronous serial port by clearing the SYNC bit and setting the SPEN bit.
3. If interrupts are required, set the RCEN bit and select the desired priority level with the RCxIP bit.
4. Set the RX9 bit to enable 9-bit reception.
5. Set the ADDEN bit to enable address detect.
6. Enable reception by setting the CREN bit.
7. The RCxIF bit will be set when reception is complete. The interrupt will be Acknowledged if the RCxIE and GIE bits are set.
8. Read the RCSTAx register to determine if any error occurred during reception, as well as read bit 9 of data (if applicable).
9. Read RCREGx to determine if the device is being addressed.
10. If any error occurred, clear the CREN bit.
11. If the device has been addressed, clear the ADDEN bit to allow all received data into the receive buffer and interrupt the CPU.

FIGURE 19-5: EUSART RECEIVE BLOCK DIAGRAM

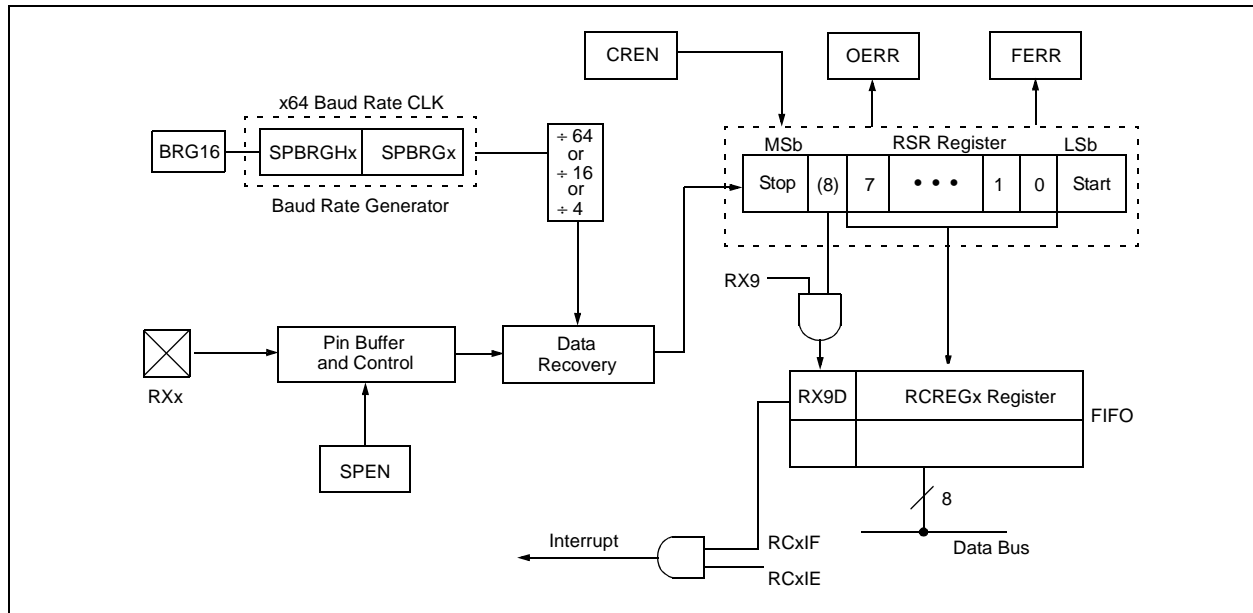

PIC18F6525/6621/8525/8621

FIGURE 19-6: ASYNCHRONOUS RECEPTION

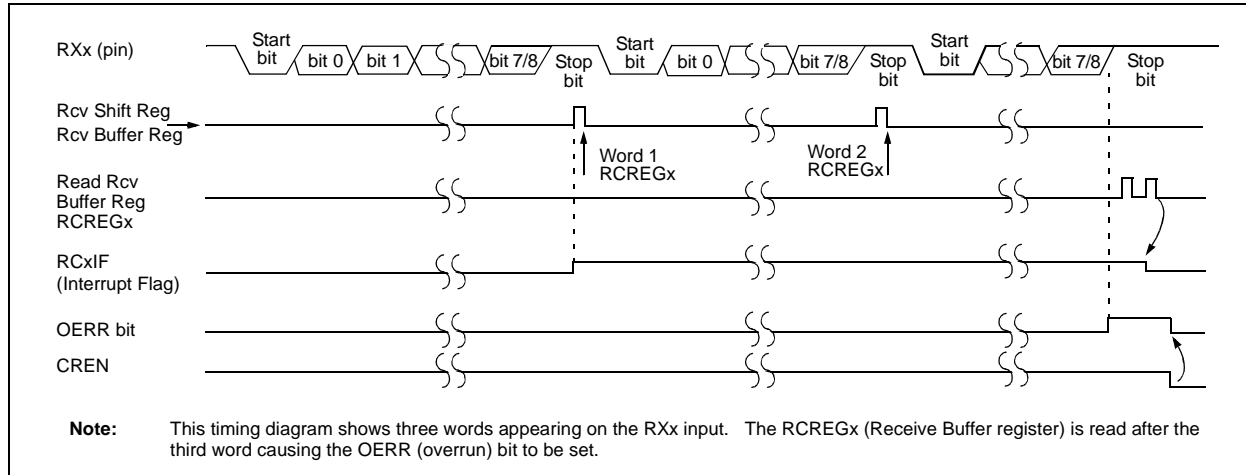

TABLE 19-6: REGISTERS ASSOCIATED WITH ASYNCHRONOUS RECEPTION

Name	Bit 7	Bit 6	Bit 5	Bit 4	Bit 3	Bit 2	Bit 1	Bit 0	Value on POR, BOR	Value on all other Resets
INTCON	GIE/GIEH	PEIE/GIEL	TMR0IE	INT0IE	RBIE	TMR0IF	INT0IF	RBIF	0000 000x	0000 000u
PIR1	PSPIF ⁽¹⁾	ADIF	RC1IF	TX1IF	SSPIF	CCP1IF	TMR2IF	TMR1IF	0000 0000	0000 0000
PIE1	PSPIE ⁽¹⁾	ADIE	RC1IE	TX1IE	SSPIE	CCP1IE	TMR2IE	TMR1IE	0000 0000	0000 0000
IPR1	PSPIP ⁽¹⁾	ADIP	RC1IP	TX1IP	SSPIP	CCP1IP	TMR2IP	TMR1IP	1111 1111	1111 1111
PIR3	—	—	RC2IF	TX2IF	TMR4IF	CCP5IF	CCP4IF	CCP3IF	--00 0000	--00 0000
PIE3	—	—	RC2IE	TX2IE	TMR4IE	CCP5IE	CCP4IE	CCP3IE	--00 0000	--00 0000
IPR3	—	—	RC2IP	TX2IP	TMR4IP	CCP5IP	CCP4IP	CCP3IP	--11 1111	--11 1111
RCSTAx	SPEN	RX9	SREN	CREN	ADDEN	FERR	OERR	RX9D	0000 000x	0000 000x
RCREGx	Enhanced USARTx Receive Register								0000 0000	0000 0000
TXSTAx	CSRC	TX9	TXEN	SYNC	SENDB	BRGH	TRMT	TX9D	0000 0010	0000 0010
BAUDCONx	—	RCIDL	—	SCKP	BRG16	—	WUE	ABDEN	-1-0 0-00	-1-0 0-00
SPBRGHx	Enhanced USARTx Baud Rate Generator Register High Byte								0000 0000	0000 0000
SPBRGx	Enhanced USARTx Baud Rate Generator Register Low Byte								0000 0000	0000 0000

Legend: x = unknown, — = unimplemented locations read as '0'. Shaded cells are not used for asynchronous reception.

Note 1: Enabled only in Microcontroller mode for PIC18F8525/8621 devices.

19.2.4 AUTO-WAKE-UP ON SYNC BREAK CHARACTER

During Sleep mode, all clocks to the EUSART are suspended. Because of this, the Baud Rate Generator is inactive and a proper byte reception cannot be performed. The Auto-Wake-up feature allows the controller to wake-up due to activity on the RXx/DTx line, while the EUSART is operating in Asynchronous mode.

The Auto-Wake-up feature is enabled by setting the WUE bit (BAUDCONx<1>). Once set, the typical receive sequence on RXx/DTx is disabled and the EUSART remains in an Idle state, monitoring for a wake-up event independent of the CPU mode. A wake-up event consists of a high-to-low transition on the RXx/DTx line. (This coincides with the start of a Sync Break or a Wake-up Signal character for the LIN protocol.)

Following a wake-up event, the module generates an RC1IF interrupt. The interrupt is generated synchronously to the Q clocks in normal operating modes (Figure 19-7) and asynchronously, if the device is in Sleep mode (Figure 19-8). The interrupt condition is cleared by reading the RCREGx register.

The WUE bit is automatically cleared once a low-to-high transition is observed on the RXx line following the wake-up event. At this point, the EUSART module is in Idle mode and returns to normal operation. This signals to the user that the Sync Break event is over.

19.2.4.1 Special Considerations Using Auto-Wake-up

Since auto-wake-up functions by sensing rising edge transitions on RXx/DTx, information with any state changes before the Stop bit may signal a false end-of-

character and cause data or framing errors. To work properly, therefore, the initial character in the transmission must be all '0's. This can be 00h (8 bytes) for standard RS-232 devices, or 000h (12 bits) for LIN bus.

Oscillator start-up time must also be considered, especially in applications using oscillators with longer start-up intervals (i.e., XT or HS mode). The Sync Break (or Wake-up Signal) character must be of sufficient length and be followed by a sufficient interval to allow enough time for the selected oscillator to start and provide proper initialization of the EUSART.

19.2.4.2 Special Considerations Using the WUE Bit

The timing of WUE and RCxIF events may cause some confusion when it comes to determining the validity of received data. As noted, setting the WUE bit places the EUSART in an Idle mode. The wake-up event causes a receive interrupt by setting the RCxIF bit. The WUE bit is cleared after this when a rising edge is seen on RXx/DTx. The interrupt condition is then cleared by reading the RCREGx register. Ordinarily, the data in RCREGx will be dummy data and should be discarded.

The fact that the WUE bit has been cleared (or is still set) and the RCxIF flag is set should not be used as an indicator of the integrity of the data in RCREGx. Users should consider implementing a parallel method in firmware to verify received data integrity.

To assure that no actual data is lost, check the RCIDL bit to verify that a receive operation is not in process. If a receive operation is not occurring, the WUE bit may then be set just prior to entering the Sleep mode.

FIGURE 19-7: AUTO-WAKE-UP BIT (WUE) TIMINGS DURING NORMAL OPERATION

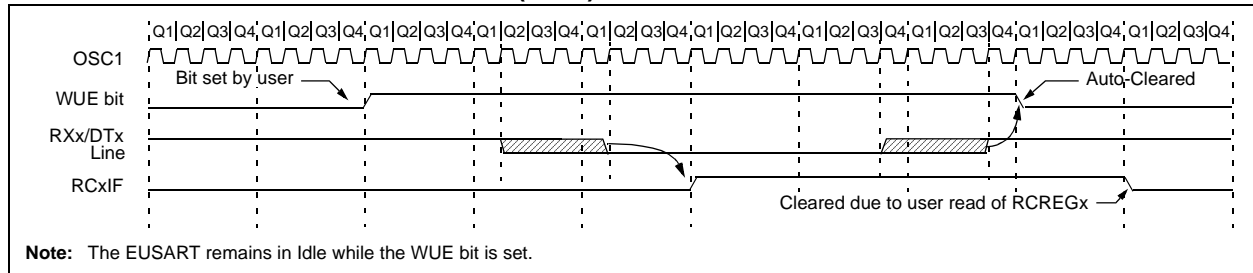
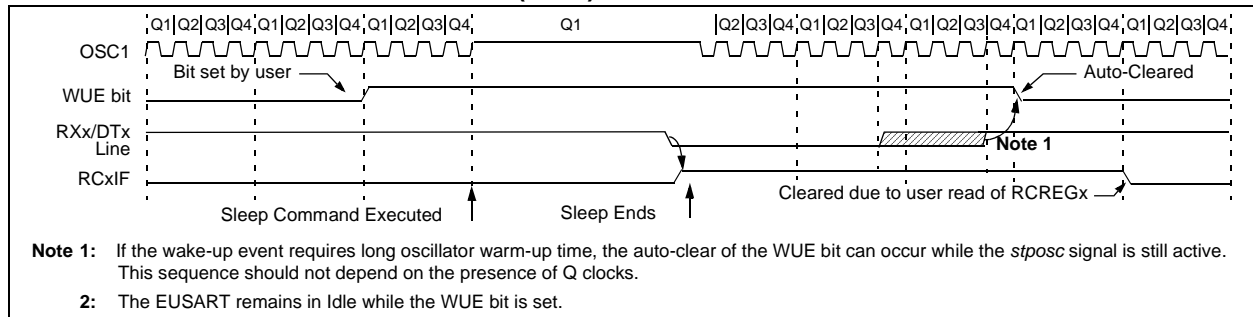

FIGURE 19-8: AUTO-WAKE-UP BIT (WUE) TIMINGS DURING SLEEP



PIC18F6525/6621/8525/8621

19.2.5 BREAK CHARACTER SEQUENCE

The Enhanced USART module has the capability of sending the special Break character sequences that are required by the LIN bus standard. The Break character transmit consists of a Start bit, followed by twelve '0' bits and a Stop bit. The frame Break character is sent whenever the SENDB and TXEN bits (TXSTAx<3> and TXSTAx<5>) are set while the Transmit Shift register is loaded with data. Note that the value of data written to TXREGx will be ignored and all '0's will be transmitted.

The SENDB bit is automatically reset by hardware after the corresponding Stop bit is sent. This allows the user to preload the transmit FIFO with the next transmit byte following the Break character (typically, the Sync character in the LIN specification).

Note that the data value written to the TXREGx for the Break character is ignored. The write simply serves the purpose of initiating the proper sequence.

The TRMT bit indicates when the transmit operation is active or Idle, just as it does during normal transmission. See Figure 19-9 for the timing of the Break character sequence.

19.2.5.1 Break and Sync Transmit Sequence

The following sequence will send a message frame header made up of a Break, followed by an auto-baud Sync byte. This sequence is typical of a LIN bus master.

1. Configure the EUSART for the desired mode.
2. Set the TXEN and SENDB bits to set up the Break character.
3. Load the TXREGx with a dummy character to initiate transmission (the value is ignored).
4. Write '55h' to TXREGx to load the Sync character into the transmit FIFO buffer.
5. After the Break has been sent, the SENDB bit is reset by hardware. The Sync character now transmits in the preconfigured mode.

When the TXREGx becomes empty, as indicated by the TXxIF, the next data byte can be written to TXREGx.

19.2.6 RECEIVING A BREAK CHARACTER

The Enhanced USART module can receive a Break character in two ways.

The first method forces configuration of the baud rate at a frequency of 9/13 the typical speed. This allows for the Stop bit transition to be at the correct sampling location (13 bits for Break versus Start bit and 8 data bits for typical data).

The second method uses the Auto-Wake-up feature described in **Section 19.2.4 "Auto-Wake-up on Sync Break Character"**. By enabling this feature, the EUSART will sample the next two transitions on RXx/DTx, cause an RCxIF interrupt and receive the next data byte followed by another interrupt.

Note that following a Break character, the user will typically want to enable the Auto-Baud Rate Detect feature. For both methods, the user can set the ABD bit once the TXxIF interrupt is observed.

FIGURE 19-9: SEND BREAK CHARACTER SEQUENCE

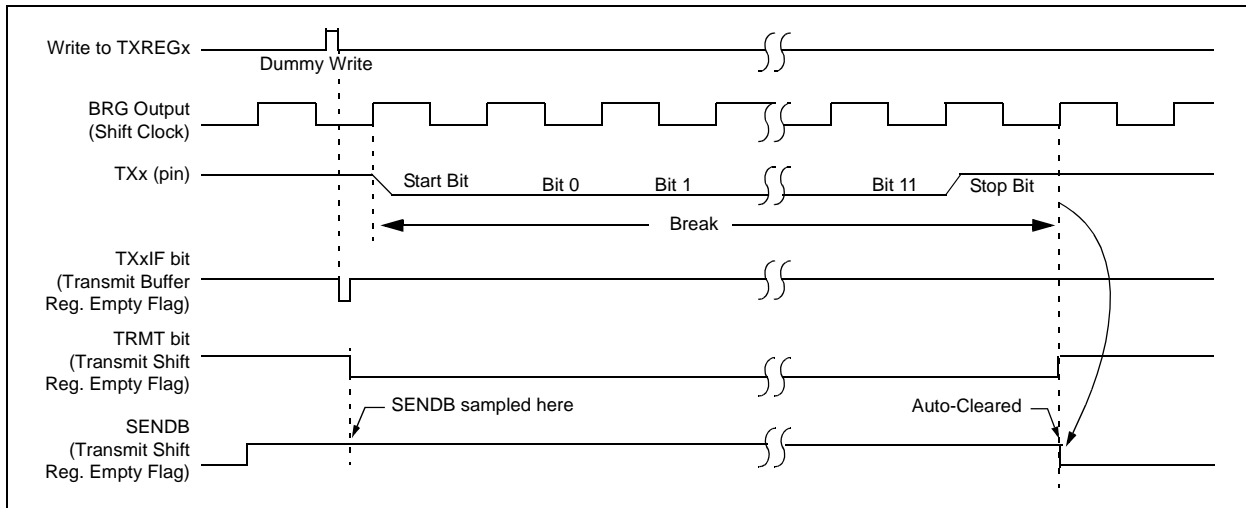

19.3 EUSART Synchronous Master Mode

The Synchronous Master mode is entered by setting the CSRC bit (TXSTAx<7>). In this mode, the data is transmitted in a half-duplex manner (i.e., transmission and reception do not occur at the same time). When transmitting data, the reception is inhibited and vice versa. Synchronous mode is entered by setting bit SYNC (TXSTAx<4>). In addition, enable bit SPEN (RCSTAx<7>) is set in order to configure the TXx and RXx pins to CKx (clock) and DTx (data) lines, respectively.

The Master mode indicates that the processor transmits the master clock on the CKx line. Clock polarity is selected with the SCKP bit (BAUDCONx<4>); setting SCKP sets the Idle state on CKx as high, while clearing the bit sets the Idle state as low. This option is provided to support Microwire devices with this module.

19.3.1 EUSART SYNCHRONOUS MASTER TRANSMISSION

The EUSART transmitter block diagram is shown in Figure 19-2. The heart of the transmitter is the Transmit (Serial) Shift Register (TSR). The Shift register obtains its data from the Read/Write Transmit Buffer register, TXREGx. The TXREGx register is loaded with data in software. The TSR register is not loaded until the last bit has been transmitted from the previous load. As soon as the last bit is transmitted, the TSR is loaded with new data from the TXREGx (if available).

Once the TXREGx register transfers the data to the TSR register (occurs in one T_{CYCLE}), the TXREGx is empty and interrupt bit TXxIF is set. The interrupt can be enabled/disabled by setting/clearing enable bit TXxIE. Flag bit TXxIF will be set regardless of the state of enable bit TXxIE and cannot be cleared in software. It will reset only when new data is loaded into the TXREGx register.

While flag bit TXxIF indicates the status of the TXREGx register, another bit, TRMT (TXSTAx<1>), shows the status of the TSR register. TRMT is a read-only bit which is set when the TSR is empty. No interrupt logic is tied to this bit so the user has to poll this bit in order to determine if the TSR register is empty. The TSR is not mapped in data memory so it is not available to the user.

To set up a Synchronous Master Transmission:

1. Initialize the SPBRGHx:SPBRGx registers for the appropriate baud rate. Set or clear the BRG16 bit, as required, to achieve the desired baud rate.
2. Enable the synchronous master serial port by setting bits SYNC, SPEN and CSRC.
3. If interrupts are desired, set enable bit TXxIE.
4. If 9-bit transmission is desired, set bit TX9.
5. Enable the transmission by setting bit TXEN.
6. If 9-bit transmission is selected, the ninth bit should be loaded in bit TX9D.
7. Start transmission by loading data to the TXREGx register.
8. If using interrupts, ensure that the GIE and PEIE bits in the INTCON register (INTCON<7:6>) are set.

FIGURE 19-10: SYNCHRONOUS TRANSMISSION

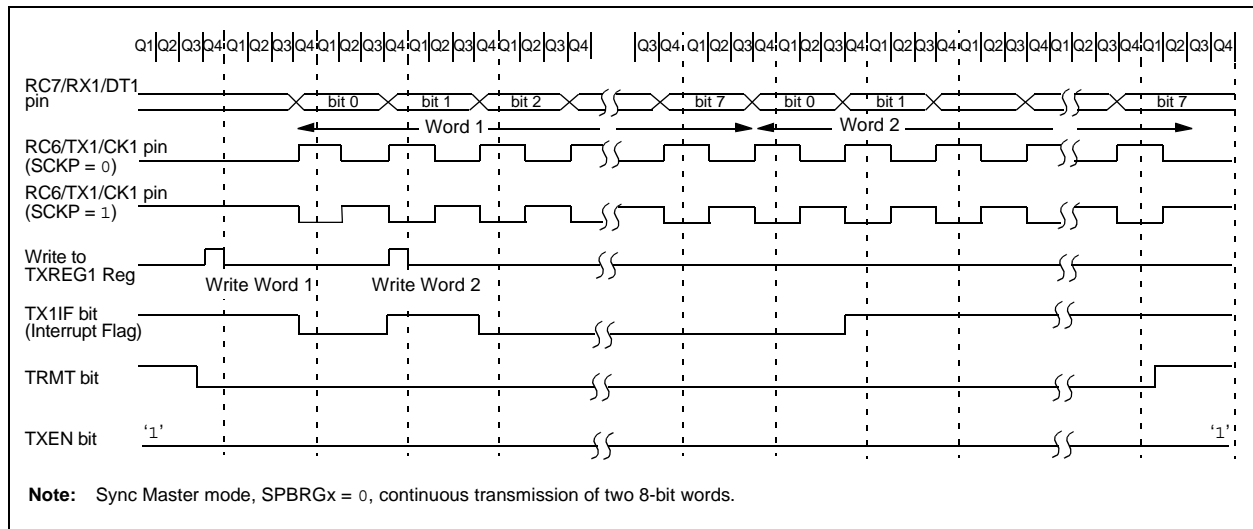

PIC18F6525/6621/8525/8621

FIGURE 19-11: SYNCHRONOUS TRANSMISSION (THROUGH TXEN)

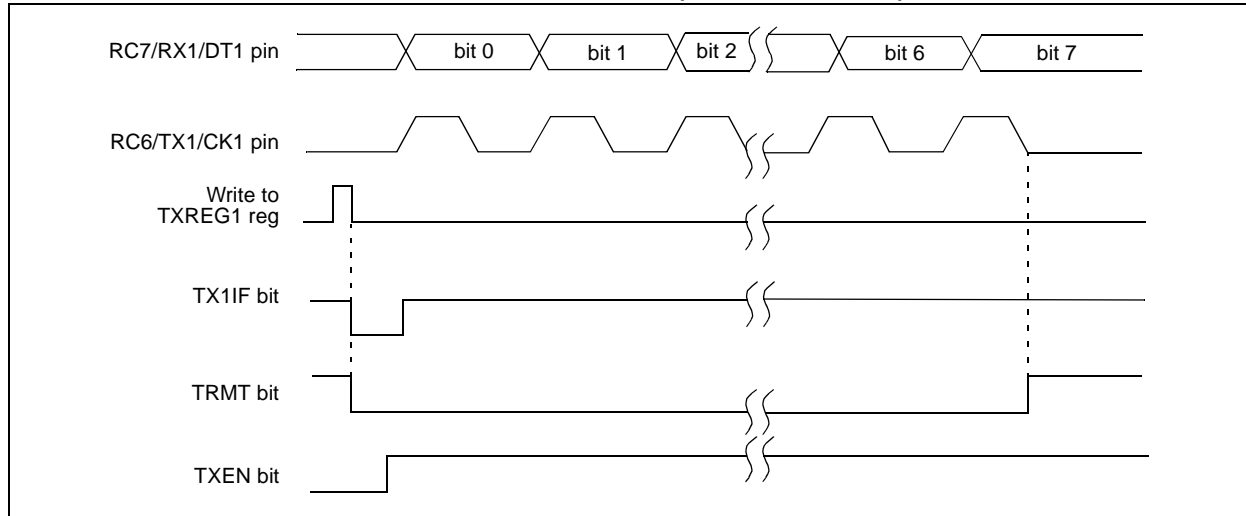

TABLE 19-7: REGISTERS ASSOCIATED WITH SYNCHRONOUS MASTER TRANSMISSION

Name	Bit 7	Bit 6	Bit 5	Bit 4	Bit 3	Bit 2	Bit 1	Bit 0	Value on POR, BOR	Value on all other Resets
INTCON	GIE/GIEH	PEIE/GIEL	TMR0IE	INT0IE	RBIE	TMR0IF	INT0IF	RBIF	0000 000x	0000 000u
PIR1	PSPIF ⁽¹⁾	ADIF	RC1IF	TX1IF	SSPIF	CCP1IF	TMR2IF	TMR1IF	0000 0000	0000 0000
PIE1	PSPIE ⁽¹⁾	ADIE	RC1IE	TX1IE	SSPIE	CCP1IE	TMR2IE	TMR1IE	0000 0000	0000 0000
IPR1	PSPIP ⁽¹⁾	ADIP	RC1IP	TX1IP	SSPIP	CCP1IP	TMR2IP	TMR1IP	1111 1111	1111 1111
PIR3	—	—	RC2IF	TX2IF	TMR4IF	CCP5IF	CCP4IF	CCP3IF	--00 0000	--00 0000
PIE3	—	—	RC2IE	TX2IE	TMR4IE	CCP5IE	CCP4IE	CCP3IE	--00 0000	--00 0000
IPR3	—	—	RC2IP	TX2IP	TMR4IP	CCP5IP	CCP4IP	CCP3IP	--11 1111	--11 1111
RCSTAx	SPEN	RX9	SREN	CREN	ADDEN	FERR	OERR	RX9D	0000 000x	0000 000x
TXREGx	Enhanced USARTx Transmit Register								0000 0000	0000 0000
TXSTAx	CSRC	TX9	TXEN	SYNC	SENDB	BRGH	TRMT	TX9D	0000 0010	0000 0010
BAUDCONx	—	RCIDL	—	SCKP	BRG16	—	WUE	ABDEN	-1-0 0-00	-1-0 0-00
SPBRGHx	Enhanced USARTx Baud Rate Generator Register High Byte								0000 0000	0000 0000
SPBRGx	Enhanced USARTx Baud Rate Generator Register Low Byte								0000 0000	0000 0000

Legend: x = unknown, — = unimplemented, read as '0'. Shaded cells are not used for synchronous master transmission.

Note 1: Enabled only in Microcontroller mode for PIC18F8525/8621 devices.

19.3.2 EUSART SYNCHRONOUS MASTER RECEPTION

Once Synchronous mode is selected, reception is enabled by setting either the Single Receive Enable bit, SREN (RCSTAx<5>), or the Continuous Receive Enable bit, CREN (RCSTAx<4>). Data is sampled on the RXx pin on the falling edge of the clock.

If enable bit SREN is set, only a single word is received. If enable bit CREN is set, the reception is continuous until CREN is cleared. If both bits are set, then CREN takes precedence.

To set up a Synchronous Master Reception:

1. Initialize the SPBRGHx:SPBRGx registers for the appropriate baud rate. Set or clear the BRG16 bit, as required, to achieve the desired baud rate.
2. Enable the synchronous master serial port by setting bits SYNC, SPEN and CSRC.
3. Ensure bits CREN and SREN are clear.
4. If interrupts are desired, set enable bit RCxIE.
5. If 9-bit reception is desired, set bit RX9.
6. If a single reception is required, set bit SREN. For continuous reception, set bit CREN.
7. Interrupt flag bit RCxIF will be set when reception is complete and an interrupt will be generated if the enable bit RCxIE was set.
8. Read the RCSTAx register to get the 9th bit (if enabled) and determine if any error occurred during reception.
9. Read the 8-bit received data by reading the RCREGx register.
10. If any error occurred, clear the error by clearing bit CREN.
11. If using interrupts, ensure that the GIE and PEIE bits in the INTCON register (INTCON<7:6>) are set.

FIGURE 19-12: SYNCHRONOUS RECEPTION (MASTER MODE, SREN)

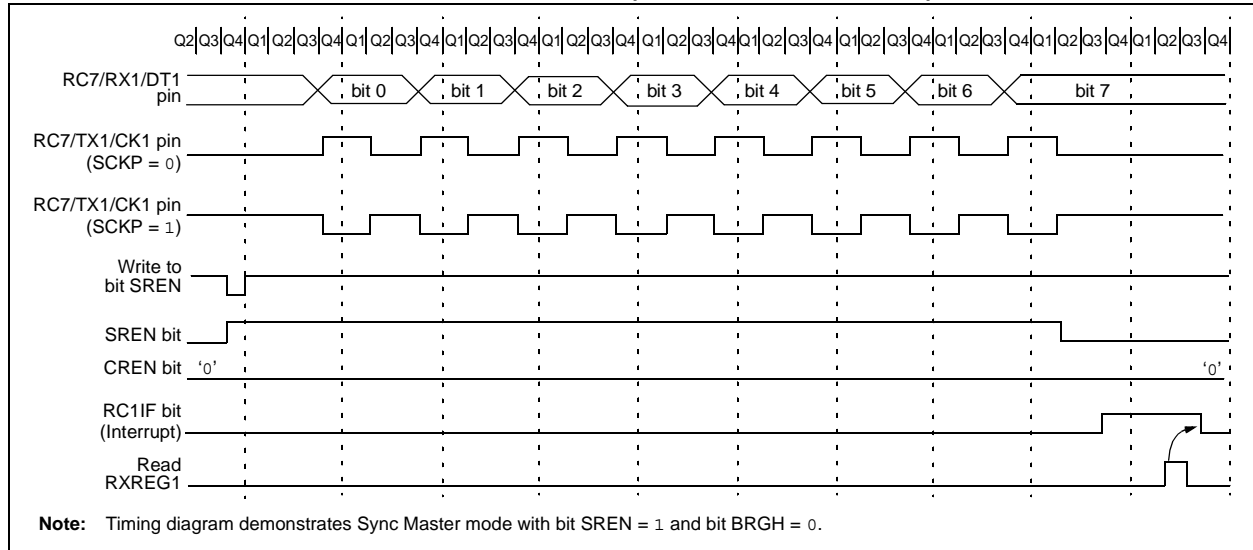

PIC18F6525/6621/8525/8621

TABLE 19-8: REGISTERS ASSOCIATED WITH SYNCHRONOUS MASTER RECEPTION

Name	Bit 7	Bit 6	Bit 5	Bit 4	Bit 3	Bit 2	Bit 1	Bit 0	Value on POR, BOR	Value on all other Resets
INTCON	GIE/GIEH	PEIE/GIEL	TMR0IE	INT0IE	RBIE	TMR0IF	INT0IF	RBIF	0000 000x	0000 000u
PIR1	PSPIF ⁽¹⁾	ADIF	RC1IF	TX1IF	SSPIF	CCP1IF	TMR2IF	TMR1IF	0000 0000	0000 0000
PIE1	PSPIE ⁽¹⁾	ADIE	RC1IE	TX1IE	SSPIE	CCP1IE	TMR2IE	TMR1IE	0000 0000	0000 0000
IPR1	PSPIP ⁽¹⁾	ADIP	RC1IP	TX1IP	SSPIP	CCP1IP	TMR2IP	TMR1IP	1111 1111	1111 1111
PIR3	—	—	RC2IF	TX2IF	TMR4IF	CCP5IF	CCP4IF	CCP3IF	--00 0000	--00 0000
PIE3	—	—	RC2IE	TX2IE	TMR4IE	CCP5IE	CCP4IE	CCP3IE	--00 0000	--00 0000
IPR3	—	—	RC2IP	TX2IP	TMR4IP	CCP5IP	CCP4IP	CCP3IP	--11 1111	--11 1111
RCSTAx	SPEN	RX9	SREN	CREN	ADDEN	FERR	OERR	RX9D	0000 000x	0000 000x
RCREGx	Enhanced USARTx Receive Register								0000 0000	0000 0000
TXSTAx	CSRC	TX9	TXEN	SYNC	SENDB	BRGH	TRMT	TX9D	0000 0010	0000 0010
BAUDCONx	—	RCIDL	—	SCKP	BRG16	—	WUE	ABDEN	-1-0 0-00	-1-0 0-00
SPBRGHx	Enhanced USARTx Baud Rate Generator Register High Byte								0000 0000	0000 0000
SPBRGx	Enhanced USARTx Baud Rate Generator Register Low Byte								0000 0000	0000 0000

Legend: x = unknown, – = unimplemented, read as '0'. Shaded cells are not used for synchronous master reception.

Note 1: Enabled only in Microcontroller mode for PIC18F8525/8621 devices.

PIC18F6525/6621/8525/8621

19.4 EUSART Synchronous Slave Mode

Synchronous Slave mode is entered by clearing bit CSRC (TXSTAx<7>). This mode differs from the Synchronous Master mode in that the shift clock is supplied externally at the CKx pin (instead of being supplied internally in Master mode). This allows the device to transfer or receive data while in any low-power mode.

19.4.1 EUSART SYNCHRONOUS SLAVE TRANSMIT

The operation of the Synchronous Master and Slave modes are identical except in the case of the Sleep mode.

If two words are written to the TXREGx and then the SLEEP instruction is executed, the following will occur:

- The first word will immediately transfer to the TSR register and transmit.
- The second word will remain in the TXREGx register.
- Flag bit TXxIF will not be set.
- When the first word has been shifted out of TSR, the TXREGx register will transfer the second word to the TSR and flag bit TXxIF will now be set.
- If enable bit TXxIE is set, the interrupt will wake the chip from Sleep. If the global interrupt is enabled, the program will branch to the interrupt vector.

To set up a Synchronous Slave Transmission:

- Enable the synchronous slave serial port by setting bits SYNC and SPEN and clearing bit CSRC.
- Clear bits CREN and SREN.
- If interrupts are desired, set enable bit TXxIE.
- If 9-bit transmission is desired, set bit TX9.
- Enable the transmission by setting enable bit TXEN.
- If 9-bit transmission is selected, the ninth bit should be loaded in bit TX9D.
- Start transmission by loading data to the TXREGx register.
- If using interrupts, ensure that the GIE and PEIE bits in the INTCON register (INTCON<7:6>) are set.

TABLE 19-9: REGISTERS ASSOCIATED WITH SYNCHRONOUS SLAVE TRANSMISSION

Name	Bit 7	Bit 6	Bit 5	Bit 4	Bit 3	Bit 2	Bit 1	Bit 0	Value on POR, BOR	Value on all other Resets
INTCON	GIE/GIEH	PEIE/GIEL	TMR0IE	INT0IE	RBIE	TMR0IF	INT0IF	RBIF	0000 000x	0000 000u
PIR1	PSPIF ⁽¹⁾	ADIF	RC1IF	TX1IF	SSPIF	CCP1IF	TMR2IF	TMR1IF	0000 0000	0000 0000
PIE1	PSPIE ⁽¹⁾	ADIE	RC1IE	TX1IE	SSPIE	CCP1IE	TMR2IE	TMR1IE	0000 0000	0000 0000
IPR1	PSPIP ⁽¹⁾	ADIP	RC1IP	TX1IP	SSPIP	CCP1IP	TMR2IP	TMR1IP	1111 1111	1111 1111
PIR3	—	—	RC2IF	TX2IF	TMR4IF	CCP5IF	CCP4IF	CCP3IF	--00 0000	--00 0000
PIE3	—	—	RC2IE	TX2IE	TMR4IE	CCP5IE	CCP4IE	CCP3IE	--00 0000	--00 0000
IPR3	—	—	RC2IP	TX2IP	TMR4IP	CCP5IP	CCP4IP	CCP3IP	--11 1111	--11 1111
RCSTAx	SPEN	RX9	SREN	CREN	ADDEN	FERR	OERR	RX9D	0000 000x	0000 000x
TXREGx	Enhanced USARTx Transmit Register								0000 0000	0000 0000
TXSTAx	CSRC	TX9	TXEN	SYNC	SENDB	BRGH	TRMT	TX9D	0000 0010	0000 0010
BAUDCONx	—	RCIDL	—	SCKP	BRG16	—	WUE	ABDEN	-1-0 0-00	-1-0 0-00
SPBRGHx	Enhanced USARTx Baud Rate Generator Register High Byte								0000 0000	0000 0000
SPBRGx	Enhanced USARTx Baud Rate Generator Register Low Byte								0000 0000	0000 0000

Legend: x = unknown, — = unimplemented, read as '0'. Shaded cells are not used for synchronous slave transmission.

Note 1: Enabled only in Microcontroller mode for PIC18F8525/8621 devices.

PIC18F6525/6621/8525/8621

19.4.2 EUSART SYNCHRONOUS SLAVE RECEPTION

The operation of the Synchronous Master and Slave modes is identical except in the case of Sleep or any Idle mode and bit SREN, which is a “don’t care” in Slave mode.

If receive is enabled by setting the CREN bit prior to entering Sleep or any Idle mode, then a word may be received while in this Low-Power mode. Once the word is received, the RSR register will transfer the data to the RCREGx register; if the RC1IE enable bit is set, the interrupt generated will wake the chip from Low-Power mode. If the global interrupt is enabled, the program will branch to the interrupt vector.

To set up a Synchronous Slave Reception:

1. Enable the synchronous master serial port by setting bits SYNC and SPEN and clearing bit CSRC.
2. If interrupts are desired, set enable bit RCxIE.
3. If 9-bit reception is desired, set bit RX9.
4. To enable reception, set enable bit CREN.
5. Flag bit RCxIF will be set when reception is complete. An interrupt will be generated if enable bit RCxIE was set.
6. Read the RCSTAx register to get the 9th bit (if enabled) and determine if any error occurred during reception.
7. Read the 8-bit received data by reading the RCREGx register.
8. If any error occurred, clear the error by clearing bit CREN.
9. If using interrupts, ensure that the GIE and PEIE bits in the INTCON register (INTCON<7:6>) are set.

TABLE 19-10: REGISTERS ASSOCIATED WITH SYNCHRONOUS SLAVE RECEPTION

Name	Bit 7	Bit 6	Bit 5	Bit 4	Bit 3	Bit 2	Bit 1	Bit 0	Value on POR, BOR	Value on all other Resets
INTCON	GIE/GIEH	PEIE/GIEL	TMR0IE	INT0IE	RBIE	TMR0IF	INT0IF	RBIF	0000 000x	0000 000u
PIR1	PSPIF ⁽¹⁾	ADIF	RC1IF	TX1IF	SSPIF	CCP1IF	TMR2IF	TMR1IF	0000 0000	0000 0000
PIE1	PSPIE ⁽¹⁾	ADIE	RC1IE	TX1IE	SSPIE	CCP1IE	TMR2IE	TMR1IE	0000 0000	0000 0000
IPR1	PSPIP ⁽¹⁾	ADIP	RC1IP	TX1IP	SSPIP	CCP1IP	TMR2IP	TMR1IP	1111 1111	1111 1111
PIR3	—	—	RC2IF	TX2IF	TMR4IF	CCP5IF	CCP4IF	CCP3IF	--00 0000	--00 0000
PIE3	—	—	RC2IE	TX2IE	TMR4IE	CCP5IE	CCP4IE	CCP3IE	--00 0000	--00 0000
IPR3	—	—	RC2IP	TX2IP	TMR4IP	CCP5IP	CCP4IP	CCP3IP	--11 1111	--11 1111
RCSTAx	SPEN	RX9	SREN	CREN	ADDEN	FERR	OERR	RX9D	0000 000x	0000 000x
RCREGx	Enhanced USARTx Receive Register								0000 0000	0000 0000
TXSTAx	CSRC	TX9	TXEN	SYNC	SENDB	BRGH	TRMT	TX9D	0000 0010	0000 0010
BAUDCONx	—	RCIDL	—	SCKP	BRG16	—	WUE	ABDEN	-1-0 0-00	-1-0 0-00
SPBRGHx	Enhanced USARTx Baud Rate Generator Register High Byte								0000 0000	0000 0000
SPBRGx	Enhanced USARTx Baud Rate Generator Register Low Byte								0000 0000	0000 0000

Legend: x = unknown, — = unimplemented, read as ‘0’. Shaded cells are not used for synchronous slave reception.

Note 1: Enabled only in Microcontroller mode for PIC18F8525/8621 devices.

PIC18F6525/6621/8525/8621

20.0 10-BIT ANALOG-TO-DIGITAL CONVERTER (A/D) MODULE

The analog-to-digital (A/D) converter module has 12 inputs for the PIC18F6525/6621 devices and 16 for the PIC18F8525/8621 devices. This module allows conversion of an analog input signal to a corresponding 10-bit digital number.

A new feature for the A/D converter is the addition of programmable acquisition time. This feature allows the user to select a new channel for conversion and setting the $\overline{\text{GO/DONE}}$ bit immediately. When the $\overline{\text{GO/DONE}}$ bit is set, the selected channel is sampled for the programmed acquisition time before a conversion is actually started. This removes the firmware overhead that may have been required to allow for an acquisition (sampling) period (see Register 20-3 and Section 20.5 “A/D Conversions”).

The module has five registers:

- A/D Result High Register (ADRESH)
- A/D Result Low Register (ADRESL)
- A/D Control Register 0 (ADCON0)
- A/D Control Register 1 (ADCON1)
- A/D Control Register 2 (ADCON2)

The ADCON0 register, shown in Register 20-1, controls the operation of the A/D module. The ADCON1 register, shown in Register 20-2, configures the functions of the port pins. The ADCON2 register, shown in Register 20-3, configures the A/D clock source, justification and auto-acquisition time.

REGISTER 20-1: ADCON0: A/D CONTROL REGISTER 0

U-0	U-0	R/W-0	R/W-0	R/W-0	R/W-0	R/W-0	R/W-0	
—	—	CHS3	CHS2	CHS1	CHS0	$\overline{\text{GO/DONE}}$	ADON	
bit 7								bit 0

bit 7-6 **Unimplemented:** Read as ‘0’

bit 5-2 **CHS3:CHS0:** Analog Channel Select bits

0000 = Channel 0 (AN0)
 0001 = Channel 1 (AN1)
 0010 = Channel 2 (AN2)
 0011 = Channel 3 (AN3)
 0100 = Channel 4 (AN4)
 0101 = Channel 5 (AN5)
 0110 = Channel 6 (AN6)
 0111 = Channel 7 (AN7)
 1000 = Channel 8 (AN8)
 1001 = Channel 9 (AN9)
 1010 = Channel 10 (AN10)
 1011 = Channel 11 (AN11)
 1100 = Channel 12 (AN12)⁽¹⁾
 1101 = Channel 13 (AN13)⁽¹⁾
 1110 = Channel 14 (AN14)⁽¹⁾
 1111 = Channel 15 (AN15)⁽¹⁾

Note 1: These channels are not available on the PIC18F6525/6621 (64-pin) devices.

bit 1 **$\overline{\text{GO/DONE}}$:** A/D Conversion Status bit

When ADON = 1:

1 = A/D conversion in progress (setting this bit starts the A/D conversion which is automatically cleared by hardware when the A/D conversion is complete)

0 = A/D conversion not in progress

bit 0 **ADON:** A/D On bit

1 = A/D converter module is enabled

0 = A/D converter module is disabled

Legend:

R = Readable bit	W = Writable bit	U = Unimplemented bit, read as ‘0’
-n = Value at POR	‘1’ = Bit is set	‘0’ = Bit is cleared x = Bit is unknown

PIC18F6525/6621/8525/8621

REGISTER 20-2: ADCON1: A/D CONTROL REGISTER 1

U-0	U-0	R/W-0	R/W-0	R/W-0	R/W-0	R/W-0	R/W-0	
—	—	VCFG1	VCFG0	PCFG3	PCFG2	PCFG1	PCFG0	
bit 7								bit 0

bit 7-6 **Unimplemented:** Read as '0'

bit 5-4 **VCFG1:VCFG0:** Voltage Reference Configuration bits:

VCFG1 VCFG0	A/D VREF+	A/D VREF-
00	AVDD	AVss
01	External VREF+	AVss
10	AVDD	External VREF-
11	External VREF+	External VREF-

bit 3-0 **PCFG3:PCFG0:** A/D Port Configuration Control bits:

PCFG3 PCFG0	AN15	AN14	AN13	AN12	AN11	AN10	AN9	AN8	AN7	AN6	AN5	AN4	AN3	AN2	AN1	AN0
0000	A	A	A	A	A	A	A	A	A	A	A	A	A	A	A	A
0001	D	D	A	A	A	A	A	A	A	A	A	A	A	A	A	A
0010	D	D	D	A	A	A	A	A	A	A	A	A	A	A	A	A
0011	D	D	D	D	A	A	A	A	A	A	A	A	A	A	A	A
0100	D	D	D	D	D	A	A	A	A	A	A	A	A	A	A	A
0101	D	D	D	D	D	D	A	A	A	A	A	A	A	A	A	A
0110	D	D	D	D	D	D	D	A	A	A	A	A	A	A	A	A
0111	D	D	D	D	D	D	D	D	A	A	A	A	A	A	A	A
1000	D	D	D	D	D	D	D	D	D	A	A	A	A	A	A	A
1001	D	D	D	D	D	D	D	D	D	D	A	A	A	A	A	A
1010	D	D	D	D	D	D	D	D	D	D	D	A	A	A	A	A
1011	D	D	D	D	D	D	D	D	D	D	D	D	A	A	A	A
1100	D	D	D	D	D	D	D	D	D	D	D	D	D	A	A	A
1101	D	D	D	D	D	D	D	D	D	D	D	D	D	D	A	A
1110	D	D	D	D	D	D	D	D	D	D	D	D	D	D	D	A
1111	D	D	D	D	D	D	D	D	D	D	D	D	D	D	D	D

A = Analog input D = Digital I/O

Note: Shaded cells indicate A/D channels available only on PIC18F8525/8621 devices.

Legend:			
R = Readable bit	W = Writable bit	U = Unimplemented bit, read as '0'	
-n = Value at POR	'1' = Bit is set	'0' = Bit is cleared	x = Bit is unknown

PIC18F6525/6621/8525/8621

REGISTER 20-3: ADCON2: A/D CONTROL REGISTER 2

R/W-0	U-0	R/W-0	R/W-0	R/W-0	R/W-0	R/W-0	R/W-0
ADFM	—	ACQT2	ACQT1	ACQT0	ADCS2	ADCS1	ADCS0
bit 7							bit 0

bit 7 **ADFM:** A/D Result Format Select bit

1 = Right justified
0 = Left justified

bit 6 **Unimplemented:** Read as '0'

bit 5-3 **ACQT2:ACQT0:** A/D Acquisition Time Select bits

000 = 0 TAD⁽¹⁾
001 = 2 TAD
010 = 4 TAD
011 = 6 TAD
100 = 8 TAD
101 = 12 TAD
110 = 16 TAD
111 = 20 TAD

bit 2-0 **ADCS2:ADCS0:** A/D Conversion Clock Select bits

000 = Fosc/2
001 = Fosc/8
010 = Fosc/32
011 = FRC (clock derived from A/D RC oscillator)⁽¹⁾
100 = Fosc/4
101 = Fosc/16
110 = Fosc/64
111 = FRC (clock derived from A/D RC oscillator)⁽¹⁾

Note 1: If the A/D FRC clock source is selected, a delay of one T_{cy} (instruction cycle) is added before the A/D clock starts. This allows the SLEEP instruction to be executed before starting a conversion.

Legend:

R = Readable bit	W = Writable bit	U = Unimplemented bit, read as '0'
-n = Value at POR	'1' = Bit is set	'0' = Bit is cleared x = Bit is unknown

PIC18F6525/6621/8525/8621

The analog reference voltage is software selectable to either the device's positive and negative supply voltage (VDD and VSS), or the voltage level on the RA3/AN3/VREF+ pin and RA2/AN2/VREF- pin.

The A/D converter has a unique feature of being able to operate while the device is in Sleep mode. To operate in Sleep, the A/D conversion clock must be derived from the A/D's internal RC oscillator.

The output of the sample and hold is the input into the converter which generates the result via successive approximation.

A device Reset forces all registers to their Reset state. This forces the A/D module to be turned off and any conversion is aborted.

Each port pin associated with the A/D converter can be configured as an analog input (RA3 can also be a voltage reference), or as a digital I/O. The ADRESH and ADRESL registers contain the result of the A/D conversion. When the A/D conversion is complete, the result is loaded into the ADRESH/ADRESL registers, the GO/DONE bit (ADCON0 register) is cleared and A/D interrupt flag bit, ADIF, is set. The block diagram of the A/D module is shown in Figure 20-1.

FIGURE 20-1: A/D BLOCK DIAGRAM

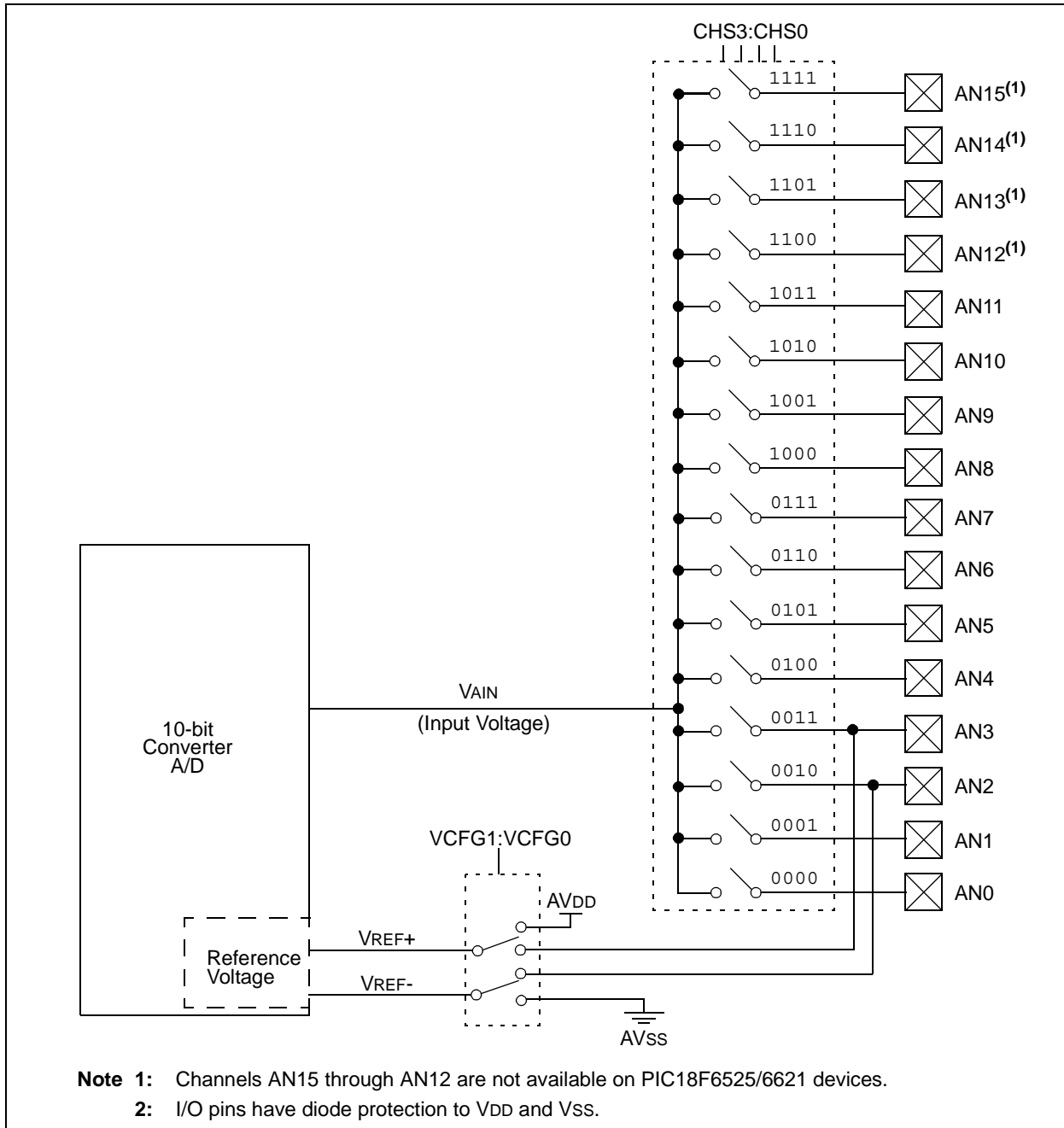

PIC18F6525/6621/8525/8621

The value in the ADRESH/ADRESL registers is not modified for a Power-on Reset. The ADRESH/ADRESL registers will contain unknown data after a Power-on Reset.

After the A/D module has been configured as desired, the selected channel must be acquired before the conversion is started. The analog input channels must have their corresponding TRIS bits selected as an input. To determine acquisition time, see **Section 20.1 "A/D Acquisition Requirements"**. After this acquisition time has elapsed, the A/D conversion can be started.

The following steps should be followed to do an A/D conversion:

1. Configure the A/D module:
 - Configure analog pins, voltage reference and digital I/O (ADCON1)
 - Select A/D input channel (ADCON0)
 - Select A/D conversion clock (ADCON2)
 - Turn on A/D module (ADCON0)
2. Configure A/D interrupt (if desired):
 - Clear ADIF bit
 - Set ADIE bit
 - Set GIE bit
3. Wait the required acquisition time (not required in case of auto-acquisition time).
4. Start conversion:
 - Set GO/DONE bit (ADCON0 register)
5. Wait for A/D conversion to complete, by either:
 - Polling for the GO/DONE bit to be cleared
 - OR
 - Waiting for the A/D interrupt
6. Read A/D Result registers (ADRESH:ADRESL); clear bit ADIF, if required.
7. For next conversion, go to step 1 or step 2, as required. The A/D conversion time per bit is defined as TAD. A minimum wait of 2 TAD is required before the next acquisition starts.

FIGURE 20-2: ANALOG INPUT MODEL

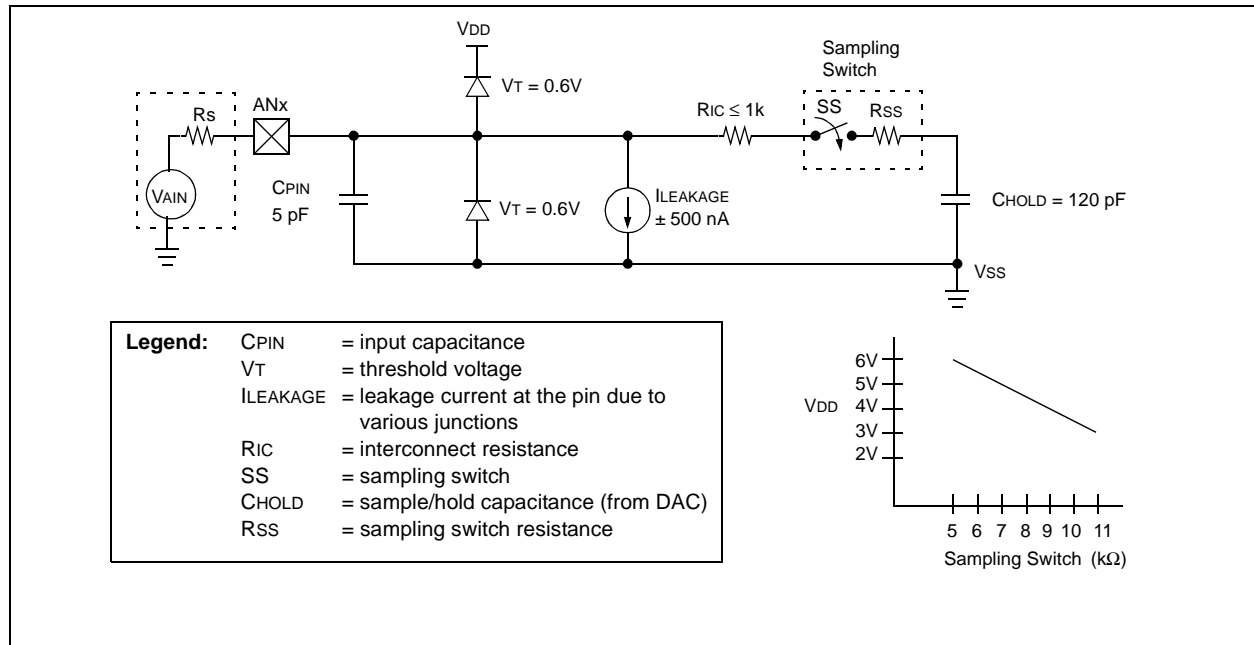

PIC18F6525/6621/8525/8621

20.1 A/D Acquisition Requirements

For the A/D converter to meet its specified accuracy, the charge holding capacitor (CHOLD) must be allowed to fully charge to the input channel voltage level. The analog input model is shown in Figure 20-2. The source impedance (Rs) and the internal sampling switch (Rss) impedance directly affect the time required to charge the capacitor CHOLD. The sampling switch (Rss) impedance varies over the device voltage (VDD). The source impedance affects the offset voltage at the analog input (due to pin leakage current). **The maximum recommended impedance for analog sources is 2.5 kΩ.** After the analog input channel is selected (changed), this acquisition must be done before the conversion can be started.

Note: When the conversion is started, the holding capacitor is disconnected from the input pin.

To calculate the minimum acquisition time, Equation 20-1 may be used. This equation assumes that 1/2 LSB error is used (1024 steps for the A/D). The 1/2 LSB error is the maximum error allowed for the A/D to meet its specified resolution.

Example 20-3 shows the calculation of the minimum required acquisition time, TACQ. This calculation is based on the following application system assumptions:

CHOLD	=	120 pF
Rs	=	2.5 kΩ
Conversion Error	≤	1/2 LSB
VDD	=	5V → Rss = 7 kΩ
Temperature	=	50°C (system max.)
VHOLD	=	0V @ time = 0

EQUATION 20-1: ACQUISITION TIME

$$\begin{aligned} TACQ &= \text{Amplifier Settling Time} + \text{Holding Capacitor Charging Time} + \text{Temperature Coefficient} \\ &= TAMP + TC + TCOFF \end{aligned}$$

EQUATION 20-2: A/D MINIMUM CHARGING TIME

$$\begin{aligned} VHOLD &= (VREF - (VREF/2048)) \cdot (1 - e^{(-Tc/CHOLD(RIC + Rss + Rs))}) \\ \text{or} \\ Tc &= -(120 \text{ pF})(1 \text{ k}\Omega + Rss + Rs) \ln(1/2047) \end{aligned}$$

EQUATION 20-3: CALCULATING THE MINIMUM REQUIRED ACQUISITION TIME

$$\begin{aligned} TACQ &= TAMP + TC + TCOFF \\ \text{Temperature coefficient is only required for temperatures } > 25^\circ\text{C.} \\ TACQ &= 2 \mu\text{s} + TC + [(Temp - 25^\circ\text{C})(0.05 \mu\text{s}/^\circ\text{C})] \\ TC &= -CHOLD (RIC + Rss + Rs) \ln(1/2047) \\ &= -120 \text{ pF} (1 \text{ k}\Omega + 7 \text{ k}\Omega + 2.5 \text{ k}\Omega) \ln(0.0004885) \\ &= -120 \text{ pF} (10.5 \text{ k}\Omega) \ln(0.0004885) \\ &= -1.26 \mu\text{s} (-7.6241) \\ &= 9.61 \mu\text{s} \\ TACQ &= 2 \mu\text{s} + 9.61 \mu\text{s} + [(50^\circ\text{C} - 25^\circ\text{C})(0.05 \mu\text{s}/^\circ\text{C})] \\ &= 11.61 \mu\text{s} + 1.25 \mu\text{s} \\ &= 12.86 \mu\text{s} \end{aligned}$$

PIC18F6525/6621/8525/8621

20.2 Selecting and Configuring Acquisition Time

The ADCON2 register allows the user to select an acquisition time that occurs each time the GO/DONE bit is set. It also gives users the option to use an automatically determined acquisition time.

Acquisition time may be set with the ACQT2:ACQT0 bits (ADCON2<5:3>), which provides a range of 2 to 20 TAD. When the GO/DONE bit is set, the A/D module continues to sample the input for the selected acquisition time, then automatically begins a conversion. Since the acquisition time is programmed, there may be no need to wait for an acquisition time between selecting a channel and setting the GO/DONE bit.

Automatic acquisition is selected when the ACQT2:ACQT0 = 000. When the GO/DONE bit is set, sampling is stopped and a conversion begins. The user is responsible for ensuring the required acquisition time has passed between selecting the desired input channel and setting the GO/DONE bit. This option is also the default Reset state of the ACQT2:ACQT0 bits and is compatible with devices that do not offer programmable acquisition times.

In either case, when the conversion is completed, the GO/DONE bit is cleared, the ADIF flag is set and the A/D begins sampling the currently selected channel again. If an acquisition time is programmed, there is nothing to indicate if the acquisition time has ended or if the conversion has begun.

20.3 Selecting the A/D Conversion Clock

The A/D conversion time per bit is defined as TAD. The A/D conversion requires 12 TAD per 10-bit conversion. The source of the A/D conversion clock is software selectable. There are seven possible options for TAD:

- 2 TOSC
- 4 TOSC
- 8 TOSC
- 16 TOSC
- 32 TOSC
- 64 TOSC
- Internal RC oscillator

For correct A/D conversions, the A/D conversion clock (TAD) must be selected to ensure a minimum TAD time of 1.6 μ s.

Table 20-1 shows the resultant TAD times derived from the device operating frequencies and the A/D clock source selected.

TABLE 20-1: TAD vs. DEVICE OPERATING FREQUENCIES

AD Clock Source (TAD)		Maximum Device Frequency
Operation	ADCS2:ADCS0	PIC18F6525/6621/8525/8621
2 TOSC	000	1.25 MHz
4 TOSC	100	2.50 MHz
8 TOSC	001	5.00 MHz
16 TOSC	101	10.0 MHz
32 TOSC	010	20.0 MHz
64 TOSC	110	40.0 MHz
RC	x11	—

PIC18F6525/6621/8525/8621

20.4 Configuring Analog Port Pins

The ADCON1, TRISA, TRISF and TRISH registers control the operation of the A/D port pins. The port pins needed as analog inputs must have their corresponding TRIS bits set (input). If the TRIS bit is cleared (output), the digital output level (VOH or VOL) will be converted.

The A/D operation is independent of the state of the CHS3:CHS0 bits and the TRIS bits.

- Note 1:** When reading the port register, all pins configured as analog input channels will read as cleared (a low level). Pins configured as a digital input will convert as an analog input. Analog levels on a digitally configured input will not affect the conversion accuracy.
- 2:** Analog levels on any pin defined as a digital input may cause the input buffer to consume current out of the device's specification limits.

20.5 A/D Conversions

Figure 20-3 shows the operation of the A/D converter after the $\overline{\text{GODONE}}$ bit has been set. Clearing the $\overline{\text{GODONE}}$ bit during a conversion will abort the current conversion. The A/D Result register pair will NOT be updated with the partially completed A/D conversion sample. That is, the ADRESH:ADRESL registers will continue to contain the value of the last completed conversion (or the last value written to the ADRESH:ADRESL registers). After the A/D conversion is aborted, a 2 TAD wait is required before the next acquisition is started. After this 2 TAD wait, acquisition on the selected channel is automatically started.

- Note:** The $\overline{\text{GODONE}}$ bit should **NOT** be set in the same instruction that turns on the A/D.

FIGURE 20-3: A/D CONVERSION TAD CYCLES

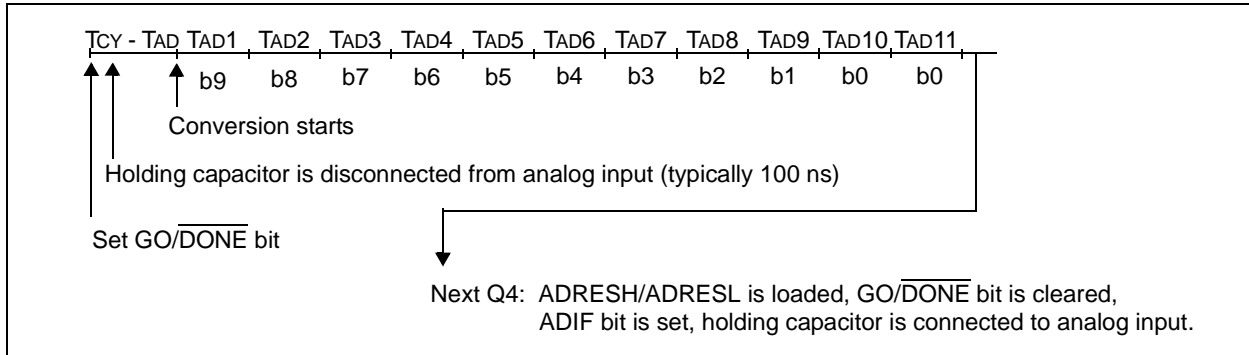

PIC18F6525/6621/8525/8621

20.6 Use of the ECCP2 Trigger

An A/D conversion can be started by the special event trigger of the ECCP2 module. This requires that the CCP2M3:CCP2M0 bits (CCP2CON<3:0>) be programmed as '1011' and that the A/D module is enabled (ADON bit is set). When the trigger occurs, the GO/DONE bit will be set, starting the A/D conversion and the Timer1 (or Timer3) counter will be reset to zero. Timer1 (or Timer3) is reset to automatically repeat the

A/D acquisition period with minimal software overhead (moving ADRESH/ADRESL to the desired location). The appropriate analog input channel must be selected and the minimum acquisition done before the special event trigger sets the GO/DONE bit and starts a conversion.

If the A/D module is not enabled (ADON is cleared), the special event trigger will be ignored by the A/D module but will still reset the Timer1 (or Timer3) counter.

TABLE 20-2: SUMMARY OF REGISTERS ASSOCIATED WITH A/D

Name	Bit 7	Bit 6	Bit 5	Bit 4	Bit 3	Bit 2	Bit 1	Bit 0	Value on POR, BOR	Value on all other Resets	
INTCON	GIE/GIEH	PEIE/GIEL	TMR0IE	INT0IE	RBIE	TMR0IF	INT0IF	RBF	0000 000x	0000 000u	
PIR1	PSPIF ⁽¹⁾	ADIF	RC1IF	TX1IF	SSPIF	CCP1IF	TMR2IF	TMR1IF	0000 0000	0000 0000	
PIE1	PSPIE ⁽¹⁾	ADIE	RC1IE	TX1IE	SSPIE	CCP1IE	TMR2IE	TMR1IE	0000 0000	0000 0000	
IPR1	PSPIP ⁽¹⁾	ADIP	RC1IP	TX1IP	SSPIP	CCP1IP	TMR2IP	TMR1IP	1111 1111	1111 1111	
PIR2	—	CMIF	—	EEIF	BCLIF	LVDIF	TMR3IF	CCP2IF	-0-0 0000	-0-0 0000	
PIE2	—	CMIE	—	EEIE	BCLIE	LVDIE	TMR3IE	CCP2IE	-0-0 0000	-0-0 0000	
IPR2	—	CMIP	—	EEIP	BCLIP	LVDIP	TMR3IP	CCP2IP	-1-1 1111	-1-1 1111	
ADRESH	A/D Result Register High Byte								xxxx xxxx	uuuu uuuu	
ADRESL	A/D Result Register Low Byte								xxxx xxxx	uuuu uuuu	
ADCON0	—	—	CHS3	CHS3	CHS1	CHS0	GO/DONE	ADON	--00 0000	--00 0000	
ADCON1	—	—	VCFG1	VCFG0	PCFG3	PCFG2	PCFG1	PCFG0	--00 0000	--00 0000	
ADCON2	ADFM	—	ACQT2	ACQT1	ACQT0	ADCS2	ADCS1	ADCS0	0-00 0000	0-00 0000	
PORTA	—	RA6 ⁽²⁾	RA5	RA4	RA3	RA2	RA1	RA0	-x0x 0000	-u0u 0000	
TRISA	—	TRISA6 ⁽²⁾	PORTA Data Direction Register							-111 1111	-111 1111
PORTF	RF7	RF6	RF5	RF4	RF3	RF2	RF1	RF0	x000 0000	u000 0000	
TRISF	PORTF Data Direction Control Register								1111 1111	1111 1111	
PORTH ⁽³⁾	RH7	RH6	RH5	RH4	RH3	RH2	RH1	RH0	0000 xxxx	0000 uuuu	
TRISH ⁽³⁾	PORTH Data Direction Control Register								1111 1111	1111 1111	

Legend: x = unknown, u = unchanged, — = unimplemented, read as '0'. Shaded cells are not used for A/D conversion.

Note 1: Enabled only in Microcontroller mode for PIC18F8525/8621 devices.

Note 2: RA6 and associated bits are configured as port pins in RCIO and ECIO Oscillator modes only and read '0' in all other oscillator modes.

Note 3: Implemented on PIC18F8525/8621 devices only, otherwise read as '0'.

PIC18F6525/6621/8525/8621

NOTES:

PIC18F6525/6621/8525/8621

21.0 COMPARATOR MODULE

The comparator module contains two analog comparators. The inputs to the comparators are multiplexed with the RF1 through RF6 pins. The on-chip Voltage Reference (**Section 22.0 “Comparator Voltage Reference Module”**) can also be an input to the comparators.

The CMCON register, shown as Register 21-1, controls the comparator input and output multiplexers. A block diagram of the various comparator configurations is shown in Figure 21-1.

REGISTER 21-1: CMCON: COMPARATOR CONTROL REGISTER

R-0	R-0	R/W-0	R/W-0	R/W-0	R/W-0	R/W-0	R/W-0
C2OUT	C1OUT	C2INV	C1INV	CIS	CM2	CM1	CM0
bit 7				bit 0			

bit 7 **C2OUT**: Comparator 2 Output bit

When C2INV = 0:

1 = C2 VIN+ > C2 VIN-

0 = C2 VIN+ < C2 VIN-

When C2INV = 1:

1 = C2 VIN+ < C2 VIN-

0 = C2 VIN+ > C2 VIN-

bit 6 **C1OUT**: Comparator 1 Output bit

When C1INV = 0:

1 = C1 VIN+ > C1 VIN-

0 = C1 VIN+ < C1 VIN-

When C1INV = 1:

1 = C1 VIN+ < C1 VIN-

0 = C1 VIN+ > C1 VIN-

bit 5 **C2INV**: Comparator 2 Output Inversion bit

1 = C2 output inverted

0 = C2 output not inverted

bit 4 **C1INV**: Comparator 1 Output Inversion bit

1 = C1 output inverted

0 = C1 output not inverted

bit 3 **CIS**: Comparator Input Switch bit

When CM2:CM0 = 110:

1 = C1 VIN- connects to RF5/AN10

C2 VIN- connects to RF3/AN8

0 = C1 VIN- connects to RF6/AN11

C2 VIN- connects to RF4/AN9

bit 2-0 **CM2:CM0**: Comparator Mode bits

Figure 21-1 shows the Comparator modes and the CM2:CM0 bit settings.

Legend:

R = Readable bit

W = Writable bit

U = Unimplemented bit, read as '0'

-n = Value at POR

'1' = Bit is set

'0' = Bit is cleared

x = Bit is unknown

PIC18F6525/6621/8525/8621

21.1 Comparator Configuration

There are eight modes of operation for the comparators. The CMCON register is used to select these modes. Figure 21-1 shows the eight possible modes. The TRISF register controls the data direction of the comparator pins for each mode. If the Comparator

mode is changed, the comparator output level may not be valid for the specified mode change delay shown in Section 27.0 “Electrical Characteristics”.

Note: Comparator interrupts should be disabled during a Comparator mode change; otherwise, a false interrupt may occur.

FIGURE 21-1: COMPARATOR I/O OPERATING MODES

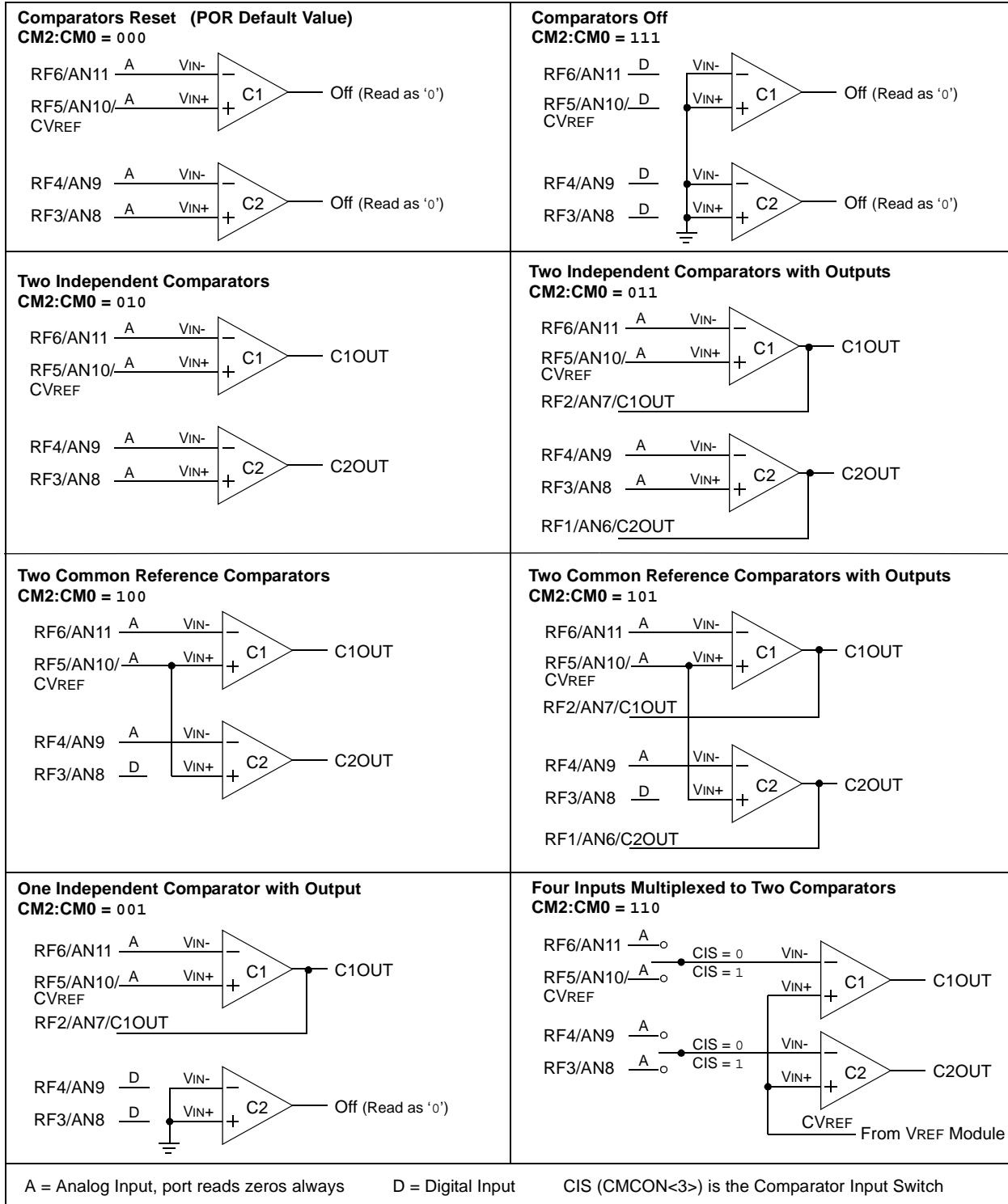

21.2 Comparator Operation

A single comparator is shown in Figure 21-2, along with the relationship between the analog input levels and the digital output. When the analog input at V_{IN+} is less than the analog input V_{IN-} , the output of the comparator is a digital low level. When the analog input at V_{IN+} is greater than the analog input V_{IN-} , the output of the comparator is a digital high level. The shaded areas of the output of the comparator in Figure 21-2 represent the uncertainty due to input offsets and response time.

21.3 Comparator Reference

An external or internal reference signal may be used depending on the comparator operating mode. The analog signal present at V_{IN-} is compared to the signal at V_{IN+} and the digital output of the comparator is adjusted accordingly (Figure 21-2).

FIGURE 21-2: SINGLE COMPARATOR

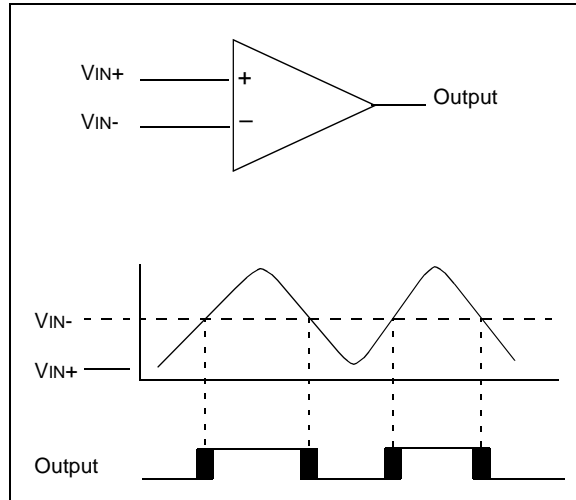

21.3.1 EXTERNAL REFERENCE SIGNAL

When external voltage references are used, the comparator module can be configured to have the comparators operate from the same, or different reference sources. However, threshold detector applications may require the same reference. The reference signal must be between V_{SS} and V_{DD} and can be applied to either pin of the comparator(s).

21.3.2 INTERNAL REFERENCE SIGNAL

The comparator module also allows the selection of an internally generated voltage reference for the comparators. **Section 22.0 “Comparator Voltage Reference Module”** contains a detailed description of the comparator voltage reference module that provides this signal. The internal reference signal is used when comparators are in mode $CM\langle 2:0 \rangle = 110$ (Figure 21-1). In this mode, the internal voltage reference is applied to the V_{IN+} pin of both comparators.

21.4 Comparator Response Time

Response time is the minimum time, after selecting a new reference voltage or input source, before the comparator output has a valid level. If the internal reference is changed, the maximum delay of the internal voltage reference must be considered when using the comparator outputs. Otherwise, the maximum delay of the comparators should be used (**Section 27.0 “Electrical Characteristics”**).

21.5 Comparator Outputs

The comparator outputs are read through the $CMCON$ register. These bits are read-only. The comparator outputs may also be directly output to the $RF1$ and $RF2$ I/O pins. When enabled, multiplexors in the output path of the $RF1$ and $RF2$ pins will switch and the output of each pin will be the unsynchronized output of the comparator. The uncertainty of each of the comparators is related to the input offset voltage and the response time given in the specifications. Figure 21-3 shows the comparator output block diagram.

The $TRISA$ bits will still function as an output enable/disable for the $RF1$ and $RF2$ pins while in this mode.

The polarity of the comparator outputs can be changed using the $C2INV$ and $C1INV$ bits ($CMCON\langle 4:5 \rangle$).

Note 1: When reading the Port register, all pins configured as analog inputs will read as a '0'. Pins configured as digital inputs will convert an analog input according to the Schmitt Trigger input specification.

2: Analog levels on any pin defined as a digital input may cause the input buffer to consume more current than is specified.

PIC18F6525/6621/8525/8621

FIGURE 21-3: COMPARATOR OUTPUT BLOCK DIAGRAM

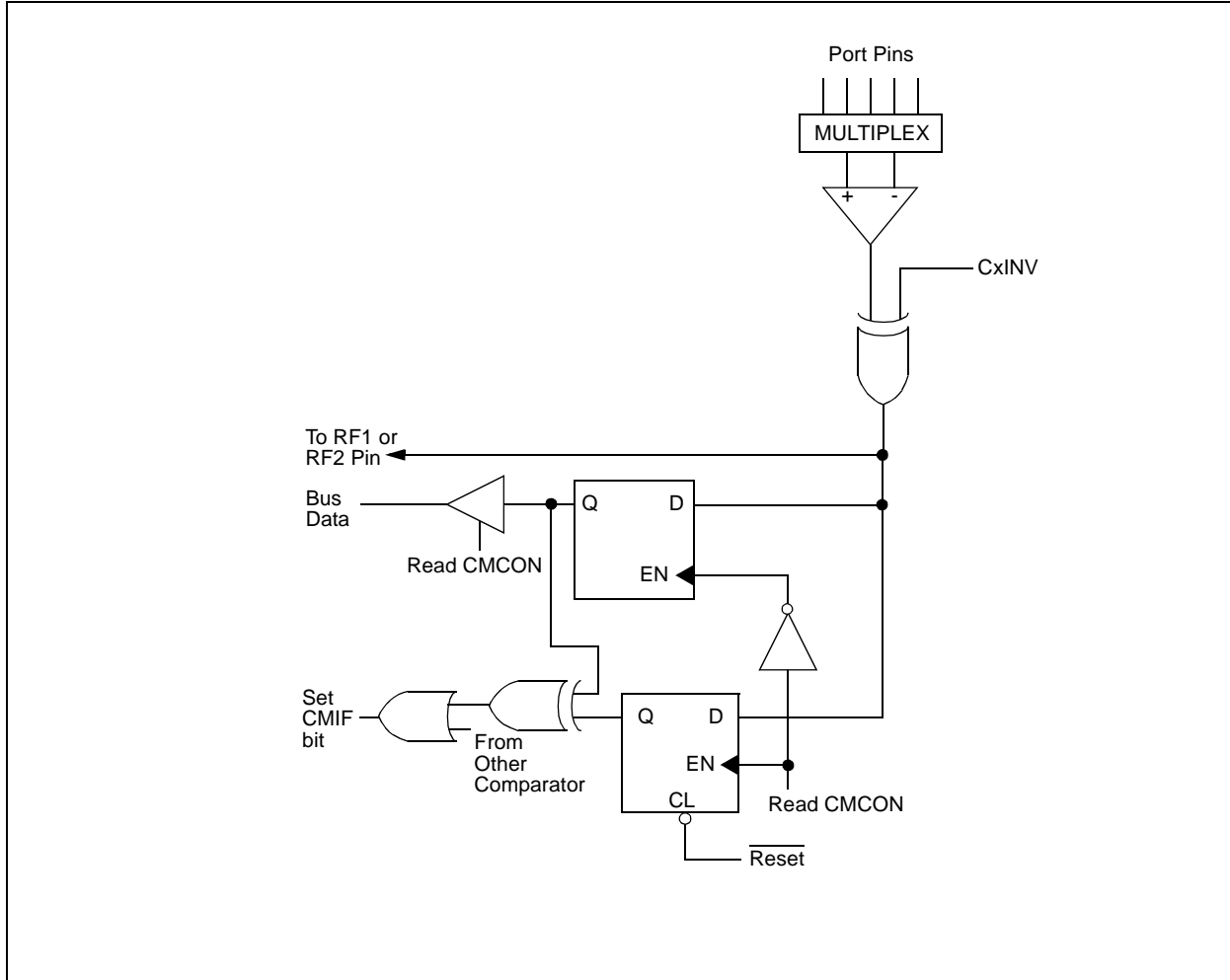

21.6 Comparator Interrupts

The comparator interrupt flag is set whenever there is a change in the output value of either comparator. Software will need to maintain information about the status of the output bits, as read from CMCON<7:6>, to determine the actual change that occurred. The CMIF bit (PIR registers) is the comparator interrupt flag. The CMIF bit must be reset by clearing '0'. Since it is also possible to write a '1' to this register, a simulated interrupt may be initiated.

The CMIE bit (PIE registers) and the PEIE bit (INTCON register) must be set to enable the interrupt. In addition, the GIE bit must also be set. If any of these bits are clear, the interrupt is not enabled, though the CMIF bit will still be set if an interrupt condition occurs.

Note: If a change in the CMCON register (C1OUT or C2OUT) should occur when a read operation is being executed (start of the Q2 cycle), then the CMIF (PIR registers) interrupt flag may not get set.

The user, in the Interrupt Service Routine, can clear the interrupt in the following manner:

- a) Any read or write of CMCON will end the mismatch condition.
- b) Clear flag bit CMIF.

A mismatch condition will continue to set flag bit CMIF. Reading CMCON will end the mismatch condition and allow flag bit CMIF to be cleared.

21.7 Comparator Operation During Sleep

When a comparator is active and the device is placed in Sleep mode, the comparator remains active and the interrupt is functional if enabled. This interrupt will wake-up the device from Sleep mode when enabled. While the comparator is powered up, higher Sleep currents than shown in the power-down current specification will occur. Each operational comparator will consume additional current, as shown in the comparator specifications. To minimize power consumption while in Sleep mode, turn off the comparators, $CM\langle 2:0 \rangle = 111$, before entering Sleep. If the device wakes up from Sleep, the contents of the CMCON register are not affected.

21.8 Effects of a Reset

A device Reset forces the CMCON register to its Reset state, causing the comparator module to be in the comparator Reset mode, $CM\langle 2:0 \rangle = 000$. This ensures that all potential inputs are analog inputs. Device current is minimized when analog inputs are present at Reset time. The comparators will be powered down during the Reset interval.

21.9 Analog Input Connection Considerations

A simplified circuit for an analog input is shown in Figure 21-4. Since the analog pins are connected to a digital output, they have reverse biased diodes to VDD and VSS. The analog input, therefore, must be between VSS and VDD. If the input voltage deviates from this range by more than 0.6V in either direction, one of the diodes is forward biased and a latch-up condition may occur. A maximum source impedance of 10 kΩ is recommended for the analog sources. Any external component connected to an analog input pin, such as a capacitor or a Zener diode, should have very little leakage current.

FIGURE 21-4: COMPARATOR ANALOG INPUT MODEL

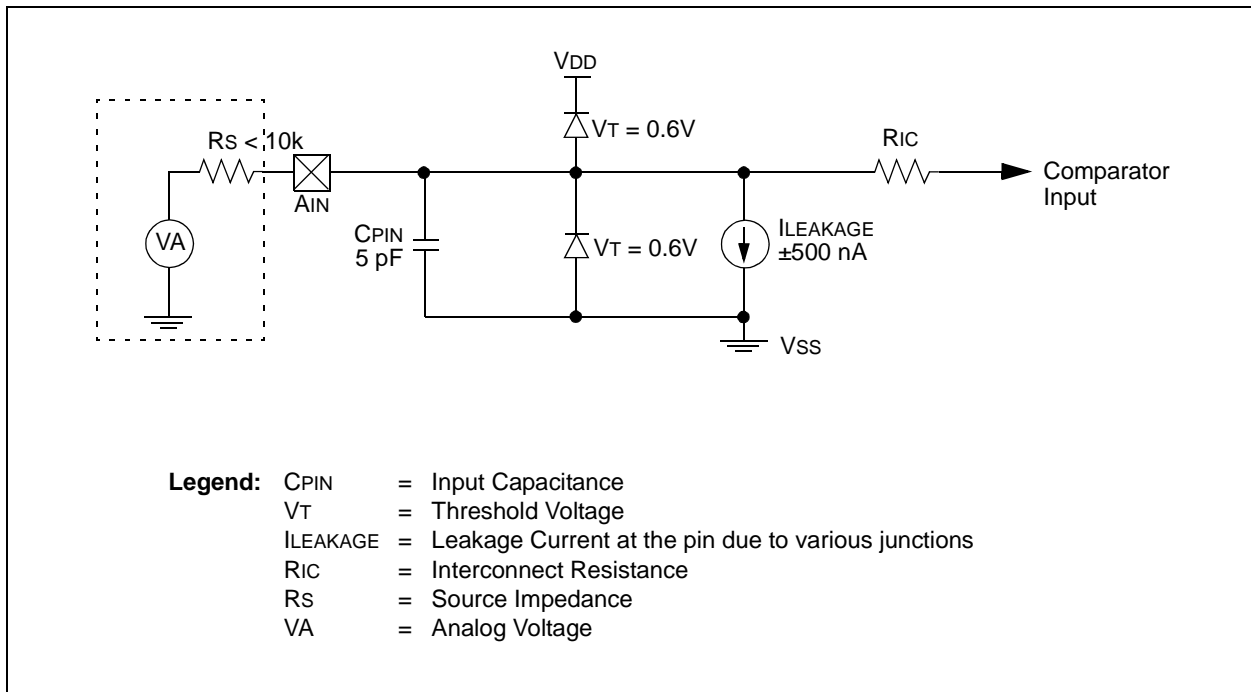

PIC18F6525/6621/8525/8621

TABLE 21-1: REGISTERS ASSOCIATED WITH COMPARATOR MODULE

Name	Bit 7	Bit 6	Bit 5	Bit 4	Bit 3	Bit 2	Bit 1	Bit 0	Value on POR	Value on all other Resets
CMCON	C2OUT	C1OUT	C2INV	C1INV	CIS	CM2	CM1	CM0	0000 0000	0000 0000
CVRCON	CVREN	CVROE	CVRR	CVRSS	CVR3	CVR2	CVR1	CVR0	0000 0000	0000 0000
INTCON	GIE/ GIEH	PEIE/ GIEL	TMR0IE	INT0IE	RBIE	TMR0IF	INT0IF	RBIF	0000 000x	0000 000u
PIR2	—	CMIF	—	EEIF	BCLIF	LVDIF	TMR3IF	CCP2IF	-0-0 0000	-0-0 0000
PIE2	—	CMIE	—	EEIE	BCLIE	LVDIE	TMR3IE	CCP2IE	-0-0 0000	-0-0 0000
IPR2	—	CMIP	—	EEIP	BCLIP	LVDIP	TMR3IP	CCP2IP	-1-1 1111	-1-1 1111
PORTF	RF7	RF6	RF5	RF4	RF3	RF2	RF1	RF0	x000 0000	u000 0000
LATF	LATF7	LATF6	LATF5	LATF4	LATF3	LATF2	LATF1	LATF0	xxxxx xxxxx	uuuu uuuu
TRISF	TRISF7	TRISF6	TRISF5	TRISF4	TRISF3	TRISF2	TRISF1	TRISF0	1111 1111	1111 1111

Legend: x = unknown, u = unchanged, — = unimplemented, read as '0'.
Shaded cells are unused by the comparator module.

22.0 COMPARATOR VOLTAGE REFERENCE MODULE

The comparator voltage reference is a 16-tap resistor ladder network that provides a selectable voltage reference. The resistor ladder is segmented to provide two ranges of CVREF values and has a power-down function to conserve power when the reference is not being used. The CVRCON register controls the operation of the reference as shown in Register 22-1. The block diagram is given in Figure 22-1.

The comparator reference supply voltage can come from either VDD and VSS, or the external VREF+ and VREF- that are multiplexed with RA3 and RA2. The comparator reference supply voltage is controlled by the CVRSS bit.

22.1 Configuring the Comparator Voltage Reference

The comparator voltage reference can output 16 distinct voltage levels for each range. The equations used to calculate the output of the comparator voltage reference are as follows:

If CVRR = 1:

$$CVREF = (CVR<3:0>/24) \times CVRSRC$$

If CVRR = 0:

$$CVREF = (CVR3 \times 1/4) + (CVR<3:0>/32) \times CVRSRC$$

The settling time of the comparator voltage reference must be considered when changing the CVREF output (**Section 27.0 “Electrical Characteristics”**).

REGISTER 22-1: CVRCON: COMPARATOR VOLTAGE REFERENCE CONTROL REGISTER

R/W-0	R/W-0	R/W-0	R/W-0	R/W-0	R/W-0	R/W-0	R/W-0
CVREN	CVROE ⁽¹⁾	CVRR	CVRSS	CVR3	CVR2	CVR1	CVR0
bit 7							bit 0

bit 7 **CVREN:** Comparator Voltage Reference Enable bit

- 1 = CVREF circuit powered on
- 0 = CVREF circuit powered down

bit 6 **CVROE:** Comparator VREF Output Enable bit⁽¹⁾

- 1 = CVREF voltage level is also output on the RF5/AN10/CVREF pin
- 0 = CVREF voltage is disconnected from the RF5/AN10/CVREF pin

Note 1: If enabled for output, RF5 must also be configured as an input by setting TRISF<5> to '1'.

bit 5 **CVRR:** Comparator VREF Range Selection bit

- 1 = 0.00 CVRSRC to 0.667 CVRSRC, with CVRSRC/24 step size (low range)
- 0 = 0.25 CVRSRC to 0.75 CVRSRC, with CVRSRC/32 step size (high range)

bit 4 **CVRSS:** Comparator VREF Source Selection bit

- 1 = Comparator reference source, CVRSRC = VREF+ – VREF-
- 0 = Comparator reference source, CVRSRC = AVDD – AVSS

bit 3-0 **CVR3:CVR0:** Comparator VREF Value Selection bits (0 ≤ VR3:VR0 ≤ 15)

When CVRR = 1:

$$CVREF = (CVR<3:0>/24) \bullet (CVRSRC)$$

When CVRR = 0:

$$CVREF = 1/4 \bullet (CVRSRC) + (CVR3:CVR0/32) \bullet (CVRSRC)$$

Legend:

R = Readable bit	W = Writable bit	U = Unimplemented bit, read as '0'
-n = Value at POR	'1' = Bit is set	'0' = Bit is cleared x = Bit is unknown

PIC18F6525/6621/8525/8621

FIGURE 22-1: COMPARATOR VOLTAGE REFERENCE BLOCK DIAGRAM

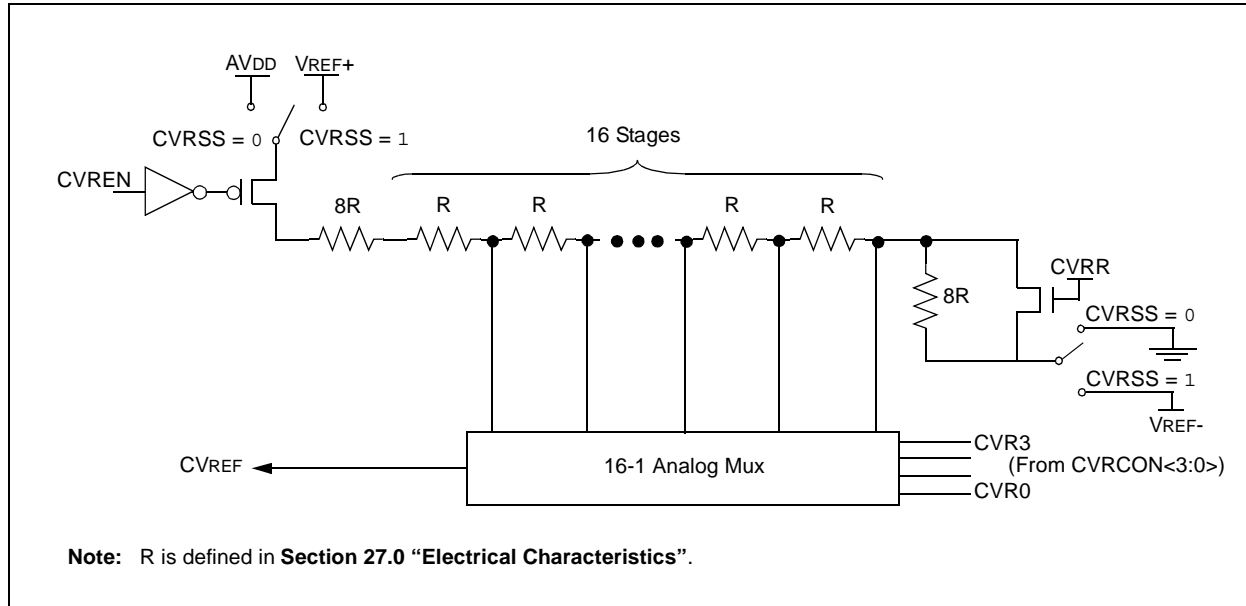

22.2 Voltage Reference Accuracy/Error

The full range of voltage reference cannot be realized due to the construction of the module. The transistors on the top and bottom of the resistor ladder network (Figure 22-1) keep CVREF from approaching the reference source rails. The voltage reference is derived from the reference source; therefore, the CVREF output changes with fluctuations in that source. The tested absolute accuracy of the voltage reference can be found in Section 27.0 "Electrical Characteristics".

22.3 Operation During Sleep

When the device wakes up from Sleep through an interrupt or a Watchdog Timer time-out, the contents of the CVRCON register are not affected. To minimize current consumption in Sleep mode, the voltage reference should be disabled.

22.4 Effects of a Reset

A device Reset disables the voltage reference by clearing bit CVREN (CVRCON<7>). This Reset also disconnects the reference from the RA2 pin by clearing bit CVROE (CVRCON<6>) and selects the high-voltage range by clearing bit CVRR (CVRCON<5>). The VRSS value select bits, CVRCON<3:0>, are also cleared.

22.5 Connection Considerations

The voltage reference module operates independently of the comparator module. The output of the reference generator may be connected to the RF5 pin if the TRISF<5> bit is set and the CVROE bit is set. Enabling the voltage reference output onto the RF5 pin configured as a digital input will increase current consumption. Connecting RF5 as a digital output with VRSS enabled will also increase current consumption.

The RF5 pin can be used as a simple D/A output with limited drive capability. Due to the limited current drive capability, a buffer must be used on the voltage reference output for external connections to VREF. Figure 22-2 shows an example buffering technique.

PIC18F6525/6621/8525/8621

FIGURE 22-2: COMPARATOR VOLTAGE REFERENCE OUTPUT BUFFER EXAMPLE

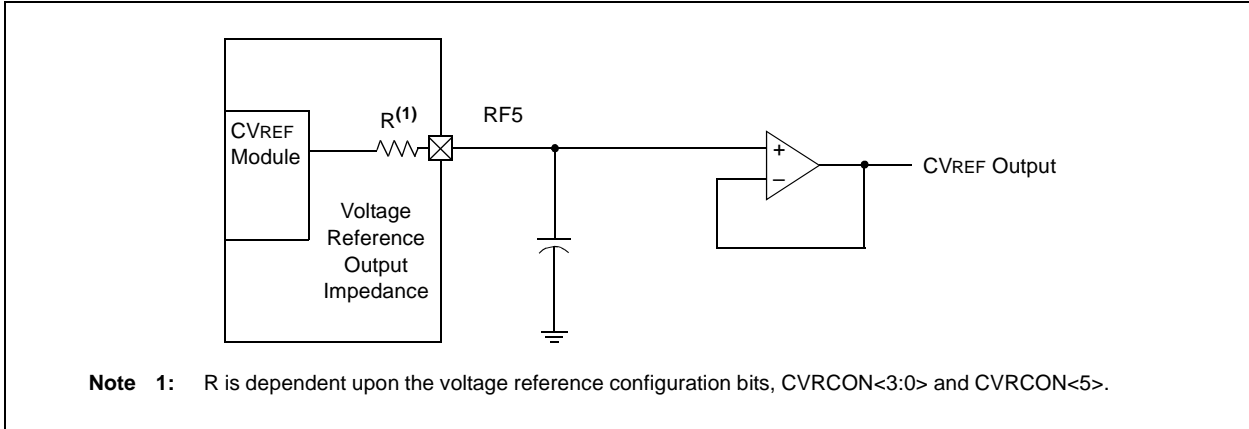

TABLE 22-1: REGISTERS ASSOCIATED WITH COMPARATOR VOLTAGE REFERENCE

Name	Bit 7	Bit 6	Bit 5	Bit 4	Bit 3	Bit 2	Bit 1	Bit 0	Value on POR	Value on all other Resets
CVRCON	CVREN	CVROE	CVRR	CVRSS	CVR3	CVR2	CVR1	CVR0	0000 0000	0000 0000
CMCON	C2OUT	C1OUT	C2INV	C1INV	CIS	CM2	CM1	CM0	0000 0000	0000 0000
TRISF	TRISF7	TRISF6	TRISF5	TRISF4	TRISF3	TRISF2	TRISF1	TRISF0	1111 1111	1111 1111

Legend: x = unknown, u = unchanged, - = unimplemented, read as '0'.
Shaded cells are not used with the comparator voltage reference.

PIC18F6525/6621/8525/8621

NOTES:

23.0 LOW-VOLTAGE DETECT

In many applications, the ability to determine if the device voltage (V_{DD}) is below a specified voltage level is a desirable feature. A window of operation for the application can be created, where the application software can do “housekeeping tasks” before the device voltage exits the valid operating range. This can be done using the Low-Voltage Detect module.

This module is a software programmable circuitry, where a device voltage trip point can be specified. When the voltage of the device becomes lower than the specified point, an interrupt flag is set. If the interrupt is enabled, the program execution will branch to the interrupt vector address and the software can then respond to that interrupt source.

The Low-Voltage Detect circuitry is completely under software control. This allows the circuitry to be “turned off” by the software which minimizes the current consumption for the device.

Figure 23-1 shows a possible application voltage curve (typically for batteries). Over time, the device voltage decreases. When the device voltage equals voltage V_A , the LVD logic generates an interrupt. This occurs at time T_A . The application software then has the time, until the device voltage is no longer in valid operating range, to shutdown the system. Voltage point V_B is the minimum valid operating voltage specification. This occurs at time T_B . The difference $T_B - T_A$ is the total time for shutdown.

FIGURE 23-1: TYPICAL LOW-VOLTAGE DETECT APPLICATION

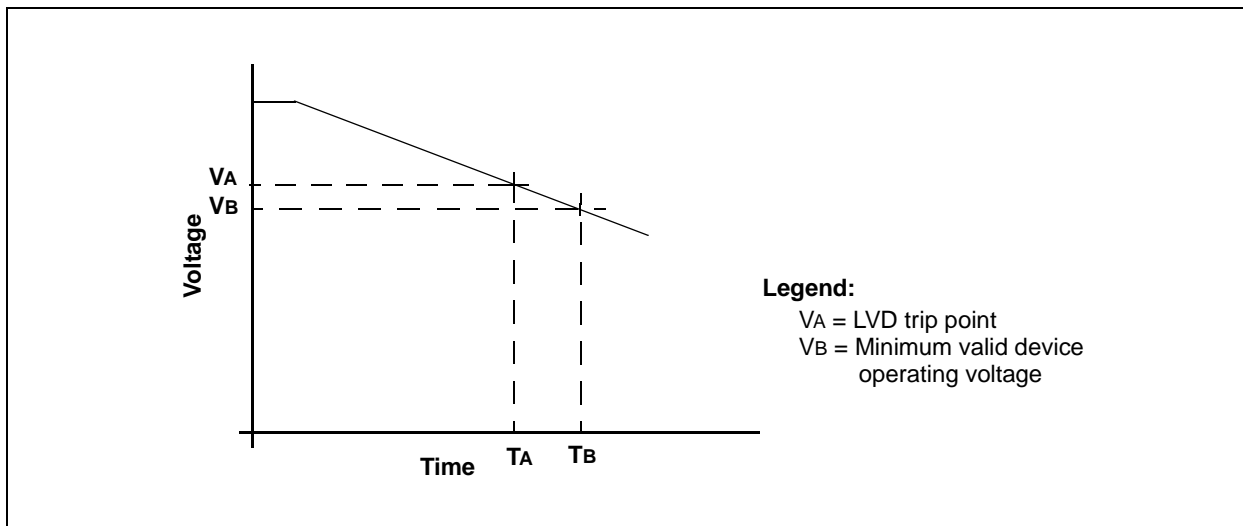

The block diagram for the LVD module is shown in Figure 23-2. A comparator uses an internally generated reference voltage as the set point. When the selected tap output of the device voltage crosses the set point (is lower than), the LVDIF bit is set.

Each node in the resistor divider represents a “trip point” voltage. The “trip point” voltage is the minimum supply voltage level at which the device can operate before the LVD module asserts an interrupt. When the

supply voltage is equal to the trip point, the voltage tapped off of the resistor array is equal to the 1.2V internal reference voltage generated by the voltage reference module. The comparator then generates an interrupt signal setting the LVDIF bit. This voltage is software programmable to any one of 16 values (see Figure 23-2). The trip point is selected by programming the LVDL3:LVDL0 bits ($LVDCON\langle 3:0 \rangle$).

PIC18F6525/6621/8525/8621

FIGURE 23-2: LOW-VOLTAGE DETECT (LVD) BLOCK DIAGRAM

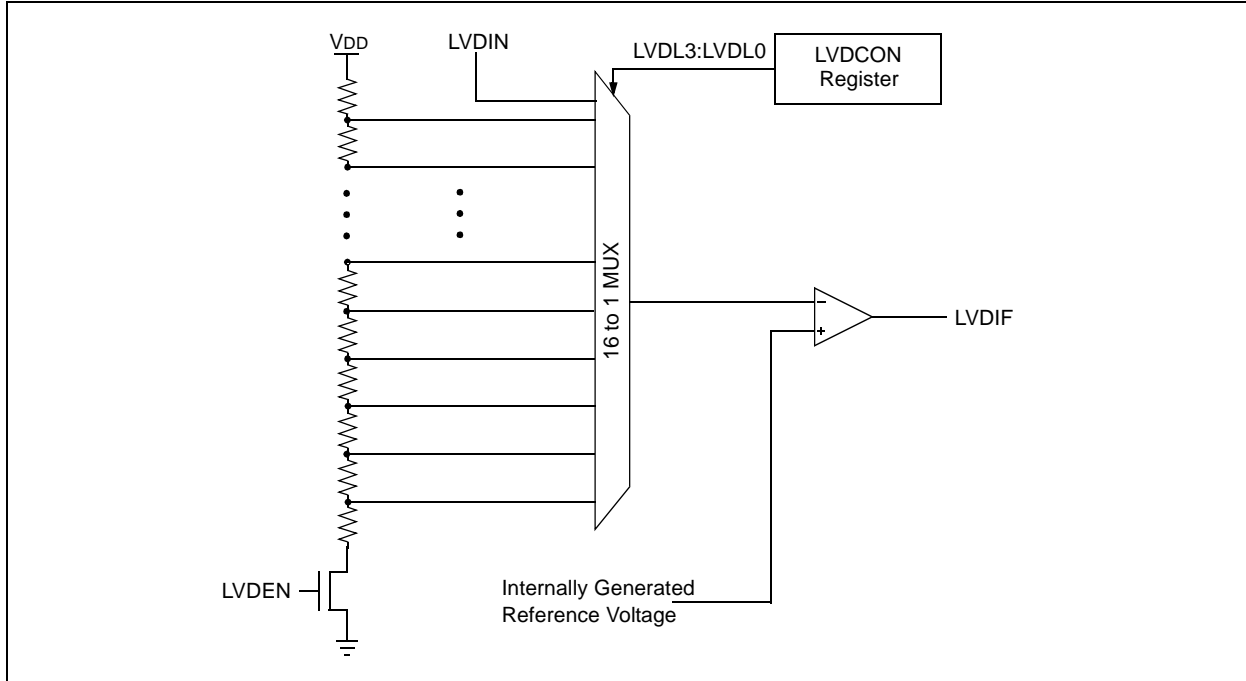

The LVD module has an additional feature that allows the user to supply the trip voltage to the module from an external source. This mode is enabled when bits LVDL3:LVDL0 are set to '1111'. In this state, the comparator input is multiplexed from the external input pin,

LVDIN (Figure 23-3). This gives users flexibility because it allows them to configure the Low-Voltage Detect interrupt to occur at any voltage in the valid operating range.

FIGURE 23-3: LOW-VOLTAGE DETECT (LVD) WITH EXTERNAL INPUT BLOCK DIAGRAM

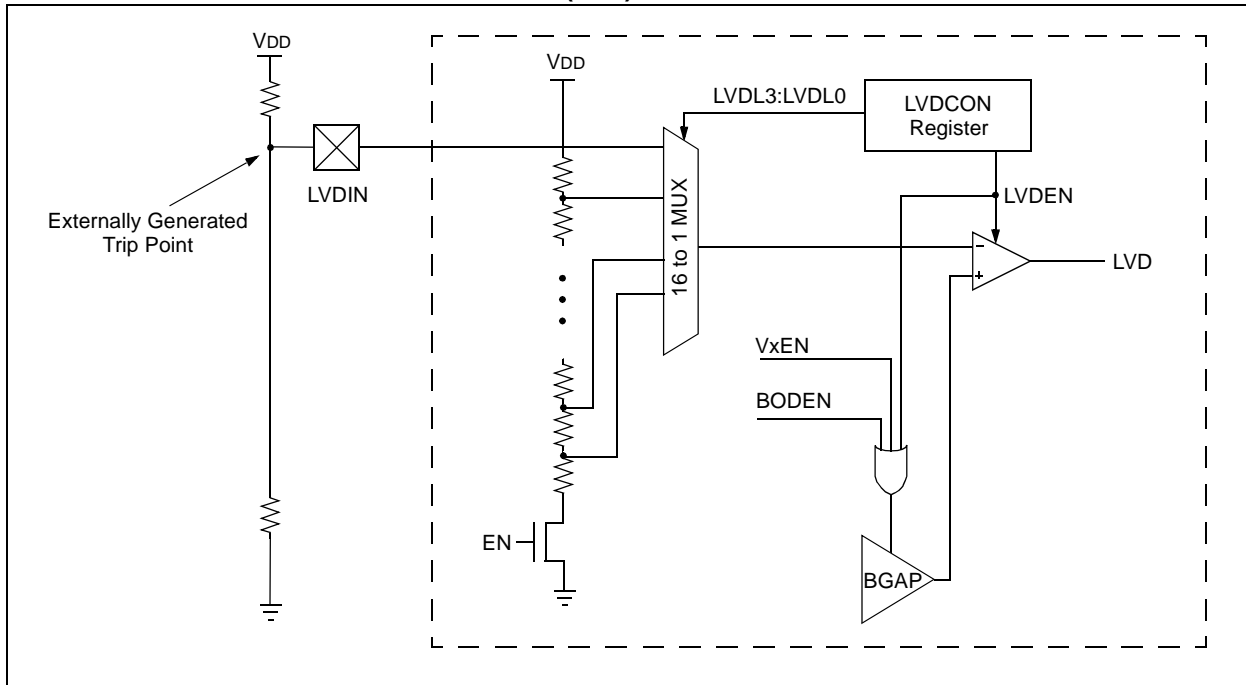

PIC18F6525/6621/8525/8621

23.1 Control Register

The Low-Voltage Detect Control register (Register 23-1) controls the operation of the Low-Voltage Detect circuitry.

REGISTER 23-1: LVDCON: LOW-VOLTAGE DETECT CONTROL REGISTER

U-0	U-0	R-0	R/W-0	R/W-0	R/W-1	R/W-0	R/W-1	
—	—	IRVST	LV DEN	LV DL3	LV DL2	LV DL1	LV DL0	
bit 7								bit 0

bit 7-6 **Unimplemented:** Read as '0'

bit 5 **IRVST:** Internal Reference Voltage Stable Flag bit

- 1 = Indicates that the Low-Voltage Detect logic will generate the interrupt flag at the specified voltage range
- 0 = Indicates that the Low-Voltage Detect logic will not generate the interrupt flag at the specified voltage range and the LVD interrupt should not be enabled

bit 4 **LV DEN:** Low-Voltage Detect Power Enable bit

- 1 = Enables LVD, powers up LVD circuit
- 0 = Disables LVD, powers down LVD circuit

bit 3-0 **LV DL3:LV DL0:** Low-Voltage Detection Limit bits

- 1111 = External analog input is used (input comes from the LVDIN pin)
- 1110 = 4.45V-4.83V
- 1101 = 4.16V-4.5V
- 1100 = 3.96V-4.3V
- 1011 = 3.76V-3.92V
- 1010 = 3.57V-3.87V
- 1001 = 3.47V-3.75V
- 1000 = 3.27V-3.55V
- 0111 = 2.98V-3.22V
- 0110 = 2.77V-3.01V
- 0101 = 2.67V-2.89V
- 0100 = 2.48V-2.68V
- 0011 = 2.37V-2.57V
- 0010 = 2.18V-2.36V
- 0001 = 1.98V-2.14V
- 0000 = Reserved

Note: LV DL3:LV DL0 modes, which result in a trip point below the valid operating voltage of the device, are not tested.

Legend:

R = Readable bit	W = Writable bit	U = Unimplemented bit, read as '0'
-n = Value at POR	'1' = Bit is set	'0' = Bit is cleared x = Bit is unknown

PIC18F6525/6621/8525/8621

23.2 Operation

Depending on the power source for the device voltage, the voltage normally decreases relatively slowly. This means that the LVD module does not need to be constantly operating. To decrease the current requirements, the LVD circuitry only needs to be enabled for short periods where the voltage is checked. After doing the check, the LVD module may be disabled.

Each time that the LVD module is enabled, the circuitry requires some time to stabilize. After the circuitry has stabilized, all status flags may be cleared. The module will then indicate the proper state of the system.

The following steps are needed to set up the LVD module:

1. Write the value to the LVDL3:LVDL0 bits (LVDCON register) which selects the desired LVD trip point.
2. Ensure that LVD interrupts are disabled (the LVDIE bit is cleared or the GIE bit is cleared).
3. Enable the LVD module (set the LVDEN bit in the LVDCON register).
4. Wait for the LVD module to stabilize (the IRVST bit to become set).
5. Clear the LVD interrupt flag, which may have falsely become set, until the LVD module has stabilized (clear the LVDIF bit).
6. Enable the LVD interrupt (set the LVDIE and the GIE bits).

Figure 23-4 shows typical waveforms that the LVD module may be used to detect.

FIGURE 23-4: LOW-VOLTAGE DETECT WAVEFORMS

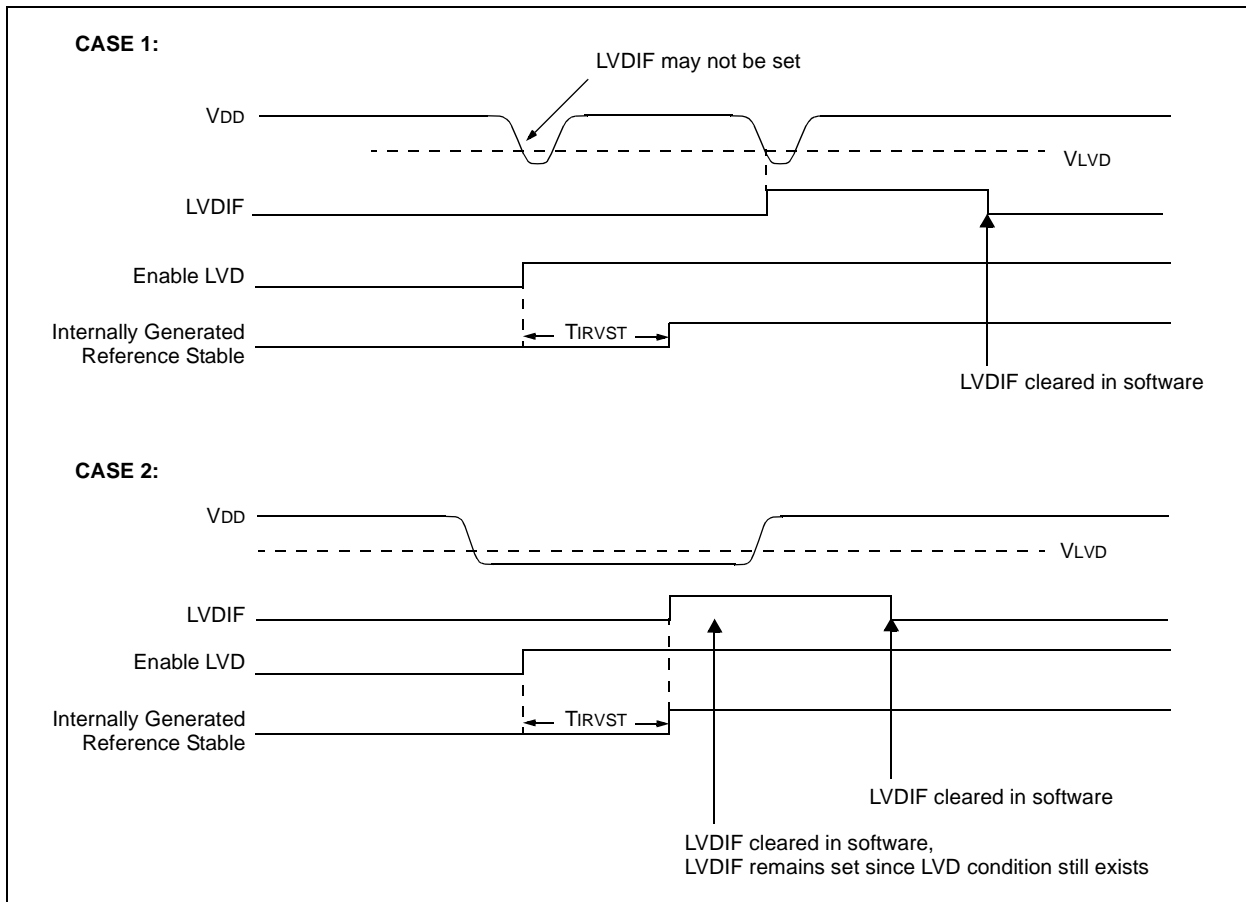

23.2.1 REFERENCE VOLTAGE SET POINT

The internal reference voltage of the LVD module may be used by other internal circuitry (the Programmable Brown-out Reset). If these circuits are disabled (lower current consumption), the reference voltage circuit requires a time to become stable before a low-voltage condition can be reliably detected. This time is invariant of system clock speed. This start-up time is specified in electrical specification parameter 36. The low-voltage interrupt flag will not be enabled until a stable reference voltage is reached. Refer to the waveform in Figure 23-4.

23.2.2 CURRENT CONSUMPTION

When the module is enabled, the LVD comparator and voltage divider are enabled and will consume static current. The voltage divider can be tapped from multiple places in the resistor array. Total current consumption, when enabled, is specified in electrical specification parameter D022B.

23.3 Operation During Sleep

When enabled, the LVD circuitry continues to operate during Sleep. If the device voltage crosses the trip point, the LVDIF bit will be set and the device will wake-up from Sleep. Device execution will continue from the interrupt vector address if interrupts have been globally enabled.

23.4 Effects of a Reset

A device Reset forces all registers to their Reset state. This forces the LVD module to be turned off.

PIC18F6525/6621/8525/8621

NOTES:

PIC18F6525/6621/8525/8621

24.0 SPECIAL FEATURES OF THE CPU

There are several features intended to maximize system reliability, minimize cost through elimination of external components, provide power-saving operating modes and offer code protection. These are:

- Oscillator Selection
- Reset
 - Power-on Reset (POR)
 - Power-up Timer (PWRT)
 - Oscillator Start-up Timer (OST)
 - Brown-out Reset (BOR)
- Interrupts
- Watchdog Timer (WDT)
- Sleep
- Code Protection
- ID Locations
- In-Circuit Serial Programming

All PIC18F6525/6621/8525/8621 devices have a Watchdog Timer which is permanently enabled via the configuration bits, or software controlled. It runs off its own RC oscillator for added reliability. There are two timers that offer necessary delays on power-up. One is the Oscillator Start-up Timer (OST), intended to keep the chip in Reset until the crystal oscillator is stable. The other is the Power-up Timer (PWRT) which provides a fixed delay on power-up only, designed to keep the part in Reset while the power supply stabilizes. With these two timers on-chip, most applications need no external Reset circuitry.

Sleep mode is designed to offer a very low current power-down mode. The user can wake-up from Sleep through external Reset, Watchdog Timer wake-up, or through an interrupt. Several oscillator options are also made available to allow the part to fit the application. The RC oscillator option saves system cost, while the LP crystal option saves power. A set of configuration bits is used to select various options.

24.1 Configuration Bits

The configuration bits can be programmed (read as '0') or left unprogrammed (read as '1'), to select various device configurations. These bits are mapped, starting at program memory location 300000h.

The user will note that address 300000h is beyond the user program memory space. In fact, it belongs to the configuration memory space (300000h through 3FFFFFh) which can only be accessed using table reads and table writes.

Programming the Configuration registers is done in a manner similar to programming the Flash memory. The EECON1 register WR bit starts a self-timed write to the Configuration register. In normal operation mode, a TBLWT instruction, with the TBLPTR pointed to the Configuration register, sets up the address and the data for the Configuration register write. Setting the WR bit starts a long write to the Configuration register. The Configuration registers are written a byte at a time. To write or erase a configuration cell, a TBLWT instruction can write a '1' or a '0' into the cell.

TABLE 24-1: CONFIGURATION BITS AND DEVICE IDS

File Name	Bit 7	Bit 6	Bit 5	Bit 4	Bit 3	Bit 2	Bit 1	Bit 0	Default/ Unprogrammed Value	
300001h	CONFIG1H	—	—	OSCSEN	—	FOSC3	FOSC2	FOSC1	FOSC0	--1- 1111
300002h	CONFIG2L	—	—	—	—	BORV1	BORV0	BOR	PWRTEN	---- 1111
300003h	CONFIG2H	—	—	—	WDTPS3	WDTPS2	WDTPS1	WDTPS0	WDTEN	---1 1111
300004h ⁽¹⁾	CONFIG3L	WAIT	—	—	—	—	—	PM1	PM0	1--- --11
300005h	CONFIG3H	MCLRE	—	—	—	—	—	ECCPMX ⁽¹⁾	CCP2MX	1--- --11
300006h	CONFIG4L	DEBUG	—	—	—	—	LVP	—	STVREN	1--- -1-1
300008h	CONFIG5L	—	—	—	—	CP3 ⁽²⁾	CP2	CP1	CP0	---- 1111
300009h	CONFIG5H	CPD	CPB	—	—	—	—	—	—	11-- ----
30000Ah	CONFIG6L	—	—	—	—	WRT3 ⁽²⁾	WRT2	WRT1	WRT0	---- 1111
30000Bh	CONFIG6H	WRTD	WRTB	WRTC	—	—	—	—	—	111- ----
30000Ch	CONFIG7L	—	—	—	—	EBTR3 ⁽²⁾	EBTR2	EBTR1	EBTR0	---- 1111
30000Dh	CONFIG7H	—	EBTRB	—	—	—	—	—	—	-1-- ----
3FFFEh	DEVID1	DEV2	DEV1	DEV0	REV4	REV3	REV2	REV1	REV0	(Note 3)
3FFFFh	DEVID2	DEV10	DEV9	DEV8	DEV7	DEV6	DEV5	DEV4	DEV3	0000 1010

Legend: x = unknown, u = unchanged, — = unimplemented. Shaded cells are unimplemented, read as '0'.

Note 1: Unimplemented in PIC18F6525/6621 devices; maintain this bit set.

2: Unimplemented in PIC18FX525 devices; maintain this bit set.

3: See Register 24-13 for DEVID1 values.

PIC18F6525/6621/8525/8621

REGISTER 24-1: CONFIG1H: CONFIGURATION REGISTER 1 HIGH (BYTE ADDRESS 300001h)

U-0	U-0	R/P-1	U-0	R/P-1	R/P-1	R/P-1	R/P-1
—	—	$\overline{\text{OSCS}}\text{EN}$	—	FOSC3	FOSC2	FOSC1	FOSC0
bit 7							bit 0

bit 7-6 **Unimplemented:** Read as '0'

bit 5 **OSCS**EN: Oscillator System Clock Switch Enable bit

1 = Oscillator system clock switch option is disabled (main oscillator is source)

0 = Timer1 oscillator system clock switch option is enabled (oscillator switching is enabled)

bit 4 **Unimplemented:** Read as '0'

bit 3-0 **FOSC3:FOSC0:** Oscillator Selection bits

1111 = RC oscillator with OSC2 configured as RA6

1110 = HS oscillator with SW enabled 4x PLL

1101 = EC oscillator with OSC2 configured as RA6 and SW enabled 4x PLL

1100 = EC oscillator with OSC2 configured as RA6 and HW enabled 4x PLL

1011 = Reserved; do not use

1010 = Reserved; do not use

1001 = Reserved; do not use

1000 = Reserved; do not use

0111 = RC oscillator with OSC2 configured as RA6

0110 = HS oscillator with HW enabled 4x PLL

0101 = EC oscillator with OSC2 configured as RA6

0100 = EC oscillator with OSC2 configured as divide by 4 clock output

0011 = RC oscillator with OSC2 configured as divide by 4 clock output

0010 = HS oscillator

0001 = XT oscillator

0000 = LP oscillator

Legend:

R = Readable bit

P = Programmable bit

U = Unimplemented bit, read as '0'

-n = Value when device is unprogrammed

u = Unchanged from programmed state

PIC18F6525/6621/8525/8621

REGISTER 24-2: CONFIG2L: CONFIGURATION REGISTER 2 LOW (BYTE ADDRESS 300002h)

U-0	U-0	U-0	U-0	R/P-1	R/P-1	R/P-1	R/P-1
—	—	—	—	BORV1	BORV0	BOR	$\overline{\text{PWRTEN}}$
bit 7				bit 0			

bit 7-4 **Unimplemented:** Read as '0'

bit 3-2 **BORV1:BORV0:** Brown-out Reset Voltage bits

11 = VBOR set to 2.0V

10 = VBOR set to 2.7V

01 = VBOR set to 4.2V

00 = VBOR set to 4.5V

bit 1 **BOR:** Brown-out Reset Enable bit

1 = Brown-out Reset enabled

0 = Brown-out Reset disabled

bit 0 **PWRTEN:** Power-up Timer Enable bit

1 = PWRT disabled

0 = PWRT enabled

Legend:

R = Readable bit

P = Programmable bit

U = Unimplemented bit, read as '0'

-n = Value when device is unprogrammed

u = Unchanged from programmed state

REGISTER 24-3: CONFIG2H: CONFIGURATION REGISTER 2 HIGH (BYTE ADDRESS 300003h)

U-0	U-0	U-0	R/P-1	R/P-1	R/P-1	R/P-1	R/P-1
—	—	—	WDTPS3	WDTPS2	WDTPS1	WDTPS0	WDTEN
bit 7							bit 0

bit 7-5 **Unimplemented:** Read as '0'

bit 4-1 **WDTPS2:WDTPS0:** Watchdog Timer Postscaler Select bits

1111 = 1:32768

1110 = 1:16384

1101 = 1:8192

1100 = 1:4096

1011 = 1:2048

1010 = 1:1024

1001 = 1:512

1000 = 1:256

0111 = 1:128

0110 = 1:64

0101 = 1:32

0100 = 1:16

0011 = 1:8

0010 = 1:4

0001 = 1:2

0000 = 1:1

bit 0 **WDTEN:** Watchdog Timer Enable bit

1 = WDT enabled

0 = WDT disabled (control is placed on the SWDTEN bit)

Legend:

R = Readable bit

P = Programmable bit

U = Unimplemented bit, read as '0'

-n = Value when device is unprogrammed

u = Unchanged from programmed state

PIC18F6525/6621/8525/8621

REGISTER 24-4: CONFIG3L: CONFIGURATION REGISTER 3 LOW (BYTE ADDRESS 300004h)⁽¹⁾

R/P-1	U-0	U-0	U-0	U-0	U-0	R/P-1	R/P-1
WAIT	—	—	—	—	—	PM1	PM0

bit 7

bit 0

bit 7 **WAIT:** External Bus Data Wait Enable bit
 1 = Wait selections unavailable for table reads and table writes
 0 = Wait selections for table reads and table writes are determined by WAIT1:WAIT0 bits (MEMCOM<5:4>)

bit 6-2 **Unimplemented:** Read as '0'

bit 1-0 **PM1:PM0:** Processor Mode Select bits
 11 = Microcontroller mode
 10 = Microprocessor mode
 01 = Microprocessor with Boot Block mode
 00 = Extended Microcontroller mode

Note 1: This register is unimplemented for PIC18F6525/6621 devices; maintain these bits set.

Legend:

R = Readable bit P = Programmable bit U = Unimplemented bit, read as '0'
 -n = Value when device is unprogrammed u = Unchanged from programmed state

REGISTER 24-5: CONFIG3H: CONFIGURATION REGISTER 3 HIGH (BYTE ADDRESS 300005h)

R/P-1	U-0	U-0	U-0	U-0	U-0	R/P-1	R/P-1
MCLRE ⁽¹⁾	—	—	—	—	—	ECCPMX ⁽²⁾	CCP2MX

bit 7

bit 0

bit 7 **MCLRE:** MCLR Enable bit⁽¹⁾
 1 = MCLR pin enabled, RG5 input pin disabled
 0 = RG5 input enabled, MCLR disabled

bit 6-2 **Unimplemented:** Read as '0'

bit 1 **ECCPMX:** ECCP Mux bit⁽²⁾
 1 = ECCP1 (P1B/P1C) and ECCP3 (P3B/P3C) PWM outputs are multiplexed with RE6 through RE3
 0 = ECCP1 (P1B/P1C) and ECCP3 (P3B/P3C) PWM outputs are multiplexed with RH7 through RH4

bit 0 **CCP2MX:** ECCP2 Mux bit
In Microcontroller mode:
 1 = ECCP2 input/output is multiplexed with RC1
 0 = ECCP2 input/output is multiplexed with RE7
In Microprocessor, Microprocessor with Boot Block and Extended Microcontroller modes (PIC18F8525/8621 devices only):
 1 = ECCP2 input/output is multiplexed with RC1
 0 = ECCP2 input/output is multiplexed with RB3

Note 1: If MCLR is disabled, either disable Low-Voltage ICSP or hold RB5/KBI1/PGM low to ensure proper entry into ICSP mode.

2: This register is unimplemented for PIC18F6525/6621 devices; maintain these bits set.

Legend:

R = Readable bit P = Programmable bit U = Unimplemented bit, read as '0'
 -n = Value when device is unprogrammed u = Unchanged from programmed state

PIC18F6525/6621/8525/8621

REGISTER 24-6: CONFIG4L: CONFIGURATION REGISTER 4 LOW (BYTE ADDRESS 300006h)

R/P-1	U-0	U-0	U-0	U-0	R/P-1	U-0	R/P-1
DEBUG	—	—	—	—	LVP	—	STVREN
bit 7							bit 0

- bit 7 **DEBUG:** Background Debugger Enable bit
 1 = Background debugger disabled. RB6 and RB7 configured as general purpose I/O pins.
 0 = Background debugger enabled. RB6 and RB7 are dedicated to in-circuit debug.
- bit 6-3 **Unimplemented:** Read as '0'
- bit 2 **LVP:** Low-Voltage ICSP Enable bit
 1 = Low-Voltage ICSP enabled
 0 = Low-Voltage ICSP disabled
- bit 1 **Unimplemented:** Read as '0'
- bit 0 **STVREN:** Stack Full/Underflow Reset Enable bit
 1 = Stack full/underflow will cause Reset
 0 = Stack full/underflow will not cause Reset

Legend:

R = Readable bit P = Programmable bit U = Unimplemented bit, read as '0'
 -n = Value when device is unprogrammed u = Unchanged from programmed state

REGISTER 24-7: CONFIG5L: CONFIGURATION REGISTER 5 LOW (BYTE ADDRESS 300008h)

U-0	U-0	U-0	U-0	R/C-1	R/C-1	R/C-1	R/C-1
—	—	—	—	CP3 ⁽¹⁾	CP2	CP1	CP0
bit 7							bit 0

- bit 7-4 **Unimplemented:** Read as '0'
- bit 3 **CP3:** Code Protection bit⁽¹⁾
 1 = Block 3 (00C000-00FFFFh) not code-protected
 0 = Block 3 (00C000-00FFFFh) code-protected
Note 1: Unimplemented in PIC18FX525 devices; maintain this bit set.
- bit 2 **CP2:** Code Protection bit
 1 = Block 2 (008000-00BFFFh) not code-protected
 0 = Block 2 (008000-00BFFFh) code-protected
- bit 1 **CP1:** Code Protection bit
 1 = Block 1 (004000-007FFFh) not code-protected
 0 = Block 1 (004000-007FFFh) code-protected
- bit 0 **CP0:** Code Protection bit
 1 = Block 0 (000800-003FFFh) not code-protected
 0 = Block 0 (000800-003FFFh) code-protected

Legend:

R = Readable bit C = Clearable bit U = Unimplemented bit, read as '0'
 -n = Value when device is unprogrammed u = Unchanged from programmed state

PIC18F6525/6621/8525/8621

REGISTER 24-8: CONFIG5H: CONFIGURATION REGISTER 5 HIGH (BYTE ADDRESS 300009h)

R/C-1	R/C-1	U-0	U-0	U-0	U-0	U-0	U-0	
CPD	CPB	—	—	—	—	—	—	
bit 7								bit 0

- bit 7 **CPD:** Data EEPROM Code Protection bit
 1 = Data EEPROM not code-protected
 0 = Data EEPROM code-protected
- bit 6 **CPB:** Boot Block Code Protection bit
 1 = Boot block (000000-0007FFh) not code-protected
 0 = Boot block (000000-0007FFh) code-protected
- bit 5-0 **Unimplemented:** Read as '0'

Legend:		
R = Readable bit	C = Clearable bit	U = Unimplemented bit, read as '0'
-n = Value when device is unprogrammed		u = Unchanged from programmed state

REGISTER 24-9: CONFIG6L: CONFIGURATION REGISTER 6 LOW (BYTE ADDRESS 30000Ah)

U-0	U-0	U-0	U-0	R/C-1	R/C-1	R/C-1	R/C-1
—	—	—	—	WRT3 ⁽¹⁾	WRT2	WRT1	WRT0
bit 7				bit 0			

- bit 7-4 **Unimplemented:** Read as '0'
- bit 3 **WRT3:** Write Protection bit⁽¹⁾
 1 = Block 3 (00C000-00FFFFh) not write-protected
 0 = Block 3 (00C000-00FFFFh) write-protected
Note 1: Unimplemented in PIC18FX525 devices; maintain this bit set.
- bit 2 **WRT2:** Write Protection bit
 1 = Block 2 (008000-00BFFFh) not write-protected
 0 = Block 2 (008000-00BFFFh) write-protected
- bit 1 **WRT1:** Write Protection bit
 1 = Block 1 (004000-007FFFh) not write-protected
 0 = Block 1 (004000-007FFFh) write-protected
- bit 0 **WRT0:** Write Protection bit
 1 = Block 0 (000800-003FFFh) not write-protected
 0 = Block 0 (000800-003FFFh) write-protected

Legend:		
R = Readable bit	C = Clearable bit	U = Unimplemented bit, read as '0'
-n = Value when device is unprogrammed		u = Unchanged from programmed state

PIC18F6525/6621/8525/8621

REGISTER 24-10: CONFIG6H: CONFIGURATION REGISTER 6 HIGH (BYTE ADDRESS 30000Bh)

R/C-1	R/C-1	R/C-1	U-0	U-0	U-0	U-0	U-0	
WRTD	WRTB	WRTC	—	—	—	—	—	
bit 7								bit 0

- bit 7 **WRTD:** Data EEPROM Write Protection bit
 1 = Data EEPROM not write-protected
 0 = Data EEPROM write-protected
- bit 6 **WRTB:** Boot Block Write Protection bit
 1 = Boot block (000000-0007FFh) not write-protected
 0 = Boot block (000000-0007FFh) write-protected
- bit 5 **WRTC:** Configuration Register Write Protection bit
 1 = Configuration registers (300000-3000FFh) not write-protected
 0 = Configuration registers (300000-3000FFh) write-protected
- bit 4-0 **Unimplemented:** Read as '0'

Legend:

R = Readable bit C = Clearable bit U = Unimplemented bit, read as '0'
 -n = Value when device is unprogrammed u = Unchanged from programmed state

REGISTER 24-11: CONFIG7L: CONFIGURATION REGISTER 7 LOW (BYTE ADDRESS 30000Ch)

U-0	U-0	U-0	U-0	R/C-1	R/C-1	R/C-1	R/C-1
—	—	—	—	EBTR3 ⁽¹⁾	EBTR2	EBTR1	EBTR0
bit 7				bit 0			

- bit 7-4 **Unimplemented:** Read as '0'
- bit 3 **EBTR3:** Table Read Protection bit⁽¹⁾
 1 = Block 3 (00C000-00FFFFh) not protected from table reads executed in other blocks
 0 = Block 3 (00C000-00FFFFh) protected from table reads executed in other blocks
Note 1: Unimplemented in PIC18FX525 devices; maintain this bit set.
- bit 2 **EBTR2:** Table Read Protection bit
 1 = Block 2 (008000-00BFFFh) not protected from table reads executed in other blocks
 0 = Block 2 (008000-00BFFFh) protected from table reads executed in other blocks
- bit 1 **EBTR1:** Table Read Protection bit
 1 = Block 1 (004000-007FFFh) not protected from table reads executed in other blocks
 0 = Block 1 (004000-007FFFh) protected from table reads executed in other blocks
- bit 0 **EBTR0:** Table Read Protection bit
 1 = Block 0 (000800-003FFFh) not protected from table reads executed in other blocks
 0 = Block 0 (000800-003FFFh) protected from table reads executed in other blocks

Legend:

R = Readable bit C = Clearable bit U = Unimplemented bit, read as '0'
 -n = Value when device is unprogrammed u = Unchanged from programmed state

PIC18F6525/6621/8525/8621

REGISTER 24-12: CONFIG7H: CONFIGURATION REGISTER 7 HIGH (BYTE ADDRESS 3000Dh)

U-0	R/C-1	U-0	U-0	U-0	U-0	U-0	U-0
—	EBTRB	—	—	—	—	—	—
bit 7							bit 0

bit 7 **Unimplemented:** Read as '0'

bit 6 **EBTRB:** Boot Block Table Read Protection bit

1 = Boot block (000000-0007FFh) not protected from table reads executed in other blocks

0 = Boot block (000000-0007FFh) protected from table reads executed in other blocks

bit 5-0 **Unimplemented:** Read as '0'

Legend:

R = Readable bit

C = Clearable bit

U = Unimplemented bit, read as '0'

-n = Value when device is unprogrammed

u = Unchanged from programmed state

REGISTER 24-13: DEVID1: DEVICE ID REGISTER 1 FOR PIC18F6525/6621/8525/8621 DEVICES (ADDRESS 3FFFEh)

R	R	R	R	R	R	R	R
DEV2	DEV1	DEV0	REV4	REV3	REV2	REV1	REV0
bit 7							bit 0

bit 7-5 **DEV2:DEV0:** Device ID bits

100 = PIC18F8621

101 = PIC18F6621

110 = PIC18F8525

111 = PIC18F6525

bit 4-0 **REV4:REV0:** Revision ID bits

These bits are used to indicate the device revision.

Legend:

R = Readable bit

P = Programmable bit

U = Unimplemented bit, read as '0'

-n = Value when device is unprogrammed

u = Unchanged from programmed state

REGISTER 24-14: DEVID2: DEVICE ID REGISTER 2 FOR PIC18F6525/6621/8525/8621 DEVICES (ADDRESS 3FFFFh)

R-0	R-0	R-0	R-0	R-1	R-0	R-1	R-0
DEV10	DEV9	DEV8	DEV7	DEV6	DEV5	DEV4	DEV3
bit 7							bit 0

bit 7-0 **DEV10:DEV3:** Device ID bits

These bits are used with the DEV2:DEV0 bits in the Device ID Register 1 to identify the part number.

0000 1010 = PIC18F6525/6621/8525/8621

Legend:

R = Readable bit

P = Programmable bit

U = Unimplemented bit, read as '0'

-n = Value when device is unprogrammed

u = Unchanged from programmed state

PIC18F6525/6621/8525/8621

24.2 Watchdog Timer (WDT)

The Watchdog Timer is a free running on-chip RC oscillator which does not require any external components. This RC oscillator is separate from the RC oscillator of the OSC1/CLKI pin. That means that the WDT will run even if the clock on the OSC1/CLKI and OSC2/CLKO/RA6 pins of the device has been stopped, for example, by execution of a SLEEP instruction.

During normal operation, a WDT time-out generates a device Reset (Watchdog Timer Reset). If the device is in Sleep mode, a WDT time-out causes the device to wake-up and continue with normal operation (Watchdog Timer wake-up). The \overline{TO} bit in the RCON register will be cleared upon a WDT time-out.

The Watchdog Timer is enabled or disabled by a device configuration bit, WDTEN (CONFIG2H<0>). If WDTEN is set, software execution may not disable this function. When WDTEN is cleared, the SWDTEN bit enables or disables the operation of the WDT.

The WDT time-out period values may be found in the Electrical Specifications section under parameter 31. Values for the WDT postscaler may be assigned using the configuration bits.

Note 1: The CLRWDT and SLEEP instructions clear the WDT and the postscaler if assigned to the WDT and prevent it from timing out and generating a device Reset condition.

2: When a CLRWDT instruction is executed and the postscaler is assigned to the WDT, the postscaler count will be cleared but the postscaler assignment is not changed.

24.2.1 CONTROL REGISTER

Register 24-15 shows the WDTCON register. This is a readable and writable register which contains a control bit that allows software to override the WDT enable configuration bit only when the configuration bit has disabled the WDT.

REGISTER 24-15: WDTCON: WATCHDOG TIMER CONTROL REGISTER

U-0	U-0	U-0	U-0	U-0	U-0	U-0	R/W-0
—	—	—	—	—	—	—	SWDTEN
bit 7							bit 0

bit 7-1 **Unimplemented:** Read as '0'

bit 0 **SWDTEN:** Software Controlled Watchdog Timer Enable bit

1 = Watchdog Timer is on

0 = Watchdog Timer is turned off (if CONFIG2H<0> = 0)

Legend:

R = Readable bit

W = Writable bit

U = Unimplemented bit, read as '0'

-n = Value at POR

'1' = Bit is set

'0' = Bit is cleared

x = Bit is unknown

PIC18F6525/6621/8525/8621

24.2.2 WDT POSTSCALER

The WDT has a postscaler that can extend the WDT Reset period. The postscaler is selected at the time of the device programming by the value written to the CONFIG2H Configuration register.

FIGURE 24-1: WATCHDOG TIMER BLOCK DIAGRAM

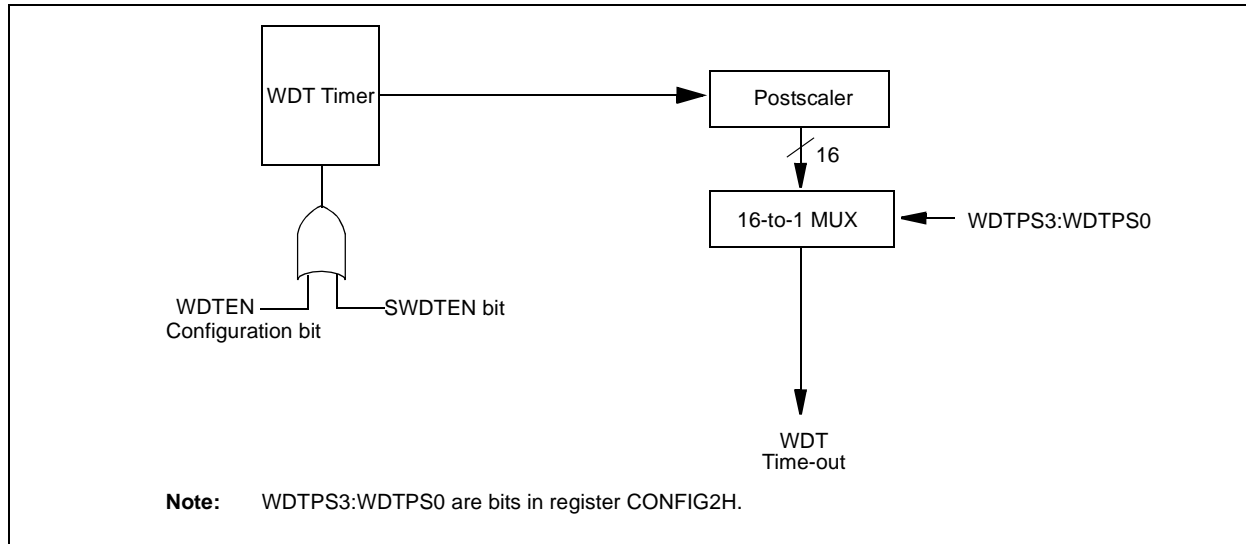

TABLE 24-2: SUMMARY OF REGISTERS ASSOCIATED WITH THE WATCHDOG TIMER

Name	Bit 7	Bit 6	Bit 5	Bit 4	Bit 3	Bit 2	Bit 1	Bit 0
CONFIG2H	—	—	—	WDTPS3	WDTPS2	WDTPS1	WDTPS0	WDTEN
RCON	IPEN	—	—	\overline{RI}	\overline{TO}	\overline{PD}	\overline{POR}	\overline{BOR}
WDTCON	—	—	—	—	—	—	—	SWDTEN

Legend: Shaded cells are not used by the Watchdog Timer.

24.3 Power-Down Mode (Sleep)

Power-down mode is entered by executing a `SLEEP` instruction.

If enabled, the Watchdog Timer will be cleared but keeps running, the `PD` bit (`RCON<3>`) is cleared, the `TO` (`RCON<4>`) bit is set and the oscillator driver is turned off. The I/O ports maintain the status they had before the `SLEEP` instruction was executed (driving high, low or high-impedance).

For lowest current consumption in this mode, place all I/O pins at either `VDD` or `VSS`, ensure no external circuitry is drawing current from the I/O pin, power-down the A/D and disable external clocks. Pull all I/O pins that are high-impedance inputs, high or low externally, to avoid switching currents caused by floating inputs. The `T0CKI` input should also be at `VDD` or `VSS` for lowest current consumption. The contribution from on-chip pull-ups on `PORTB` should be considered.

The `MCLR` pin must be at a logic high level (`VIHMC`).

24.3.1 WAKE-UP FROM SLEEP

The device can wake-up from Sleep through one of the following events:

1. External Reset input on `MCLR` pin.
2. Watchdog Timer wake-up (if WDT was enabled).
3. Interrupt from `INTx` pin, RB port change or a peripheral interrupt.

The following peripheral interrupts can wake the device from Sleep:

1. PSP read or write.
2. TMR1 interrupt. Timer1 must be operating as an asynchronous counter.
3. TMR3 interrupt. Timer3 must be operating as an asynchronous counter.
4. CCP Capture mode interrupt (Capture will not occur).
5. MSSP (Start/Stop) bit detect interrupt.
6. MSSP transmit or receive in Slave mode (`SPI/I2C`).
7. USART `RXx` or `TXx` (Synchronous Slave mode).
8. A/D conversion (when A/D clock source is RC).
9. EEPROM write operation complete.
10. LVD interrupt.

Other peripherals cannot generate interrupts since during Sleep, no on-chip clocks are present.

External `MCLR` Reset will cause a device Reset. All other events are considered a continuation of program execution and will cause a “wake-up”. The `TO` and `PD` bits in the `RCON` register can be used to determine the cause of the device Reset. The `PD` bit, which is set on power-up, is cleared when Sleep is invoked. The `TO` bit is cleared if a WDT time-out occurred (and caused wake-up).

When the `SLEEP` instruction is being executed, the next instruction (`PC + 2`) is prefetched. For the device to wake-up through an interrupt event, the corresponding interrupt enable bit must be set (enabled). Wake-up is regardless of the state of the `GIE` bit. If the `GIE` bit is clear (disabled), the device continues execution at the instruction after the `SLEEP` instruction. If the `GIE` bit is set (enabled), the device executes the instruction after the `SLEEP` instruction and then branches to the interrupt address. In cases where the execution of the instruction following Sleep is not desirable, the user should have a `NOP` after the `SLEEP` instruction.

24.3.2 WAKE-UP USING INTERRUPTS

When global interrupts are disabled (`GIE` cleared) and any interrupt source has both its interrupt enable bit and interrupt flag bit set, one of the following will occur:

- If an interrupt condition (interrupt flag bit and interrupt enable bits are set) occurs **before** the execution of a `SLEEP` instruction, the `SLEEP` instruction will complete as a `NOP`. Therefore, the `WDT` and `WDT` postscaler will not be cleared, the `TO` bit will not be set and `PD` bits will not be cleared.
- If the interrupt condition occurs **during or after** the execution of a `SLEEP` instruction, the device will immediately wake-up from Sleep. The `SLEEP` instruction will be completely executed before the wake-up. Therefore, the `WDT` and `WDT` postscaler will be cleared, the `TO` bit will be set and the `PD` bit will be cleared.

Even if the flag bits were checked before executing a `SLEEP` instruction, it may be possible for flag bits to become set before the `SLEEP` instruction completes. To determine whether a `SLEEP` instruction executed, test the `PD` bit. If the `PD` bit is set, the `SLEEP` instruction was executed as a `NOP`.

To ensure that the `WDT` is cleared, a `CLRWDT` instruction should be executed before a `SLEEP` instruction.

PIC18F6525/6621/8525/8621

FIGURE 24-2: WAKE-UP FROM SLEEP THROUGH INTERRUPT^(1,2)

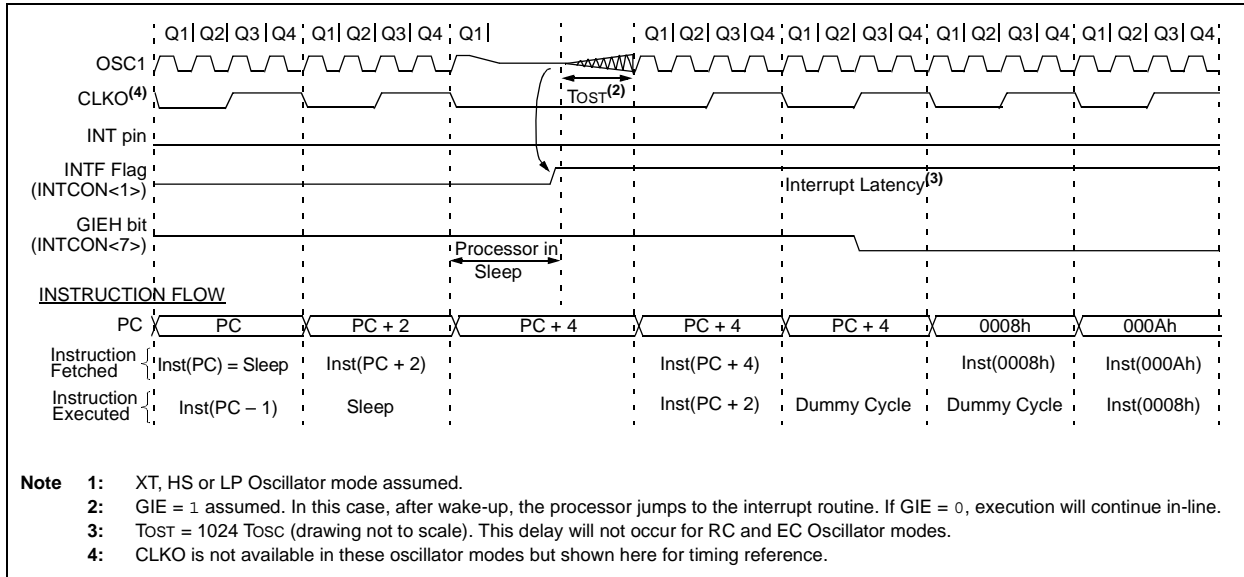

24.4 Program Verification and Code Protection

The overall structure of the code protection on the PIC18 Flash devices differs significantly from other PICmicro devices.

The user program memory is divided on binary boundaries into four blocks of 16 Kbytes each. The first block is further divided into a boot block of 2048 bytes and a second block (Block 0) of 14 Kbytes.

Each of the blocks has three code protection bits associated with them. They are:

- Code-Protect bit (CP_n)
- Write-Protect bit (WRT_n)
- External Block Table Read bit (EBTR_n)

Figure 24-3 shows the program memory organization for 48 and 64-Kbyte devices and the specific code protection bit associated with each block. The actual locations of the bits are summarized in Table 24-3.

FIGURE 24-3: CODE-PROTECTED PROGRAM MEMORY FOR PIC18F6525/6621/8525/8621 DEVICES

MEMORY SIZE/DEVICE		Address Range	Block Code Protection Controlled By:
48 Kbytes (PIC18FX525)	64 Kbytes (PIC18FX621)		
Boot Block	Boot Block	000000h 0007FFh	CPB, WRTB, EBTRB
Block 0	Block 0	000800h 003FFFh	CP0, WRT0, EBTR0
Block 1	Block 1	004000h 007FFFh	CP1, WRT1, EBTR1
Block 2	Block 2	008000h 00BFFFh	CP2, WRT2, EBTR2
Unimplemented, read '0'	Block 3	00C000h 00FFFFh	CP3, WRT3, EBTR3

PIC18F6525/6621/8525/8621

TABLE 24-3: SUMMARY OF REGISTERS ASSOCIATED WITH CODE PROTECTION

File Name		Bit 7	Bit 6	Bit 5	Bit 4	Bit 3	Bit 2	Bit 1	Bit 0
300008h	CONFIG5L	—	—	—	—	CP3 ⁽¹⁾	CP2	CP1	CP0
300009h	CONFIG5H	CPD	CPB	—	—	—	—	—	—
30000Ah	CONFIG6L	—	—	—	—	WRT3 ⁽¹⁾	WRT2	WRT1	WRT0
30000Bh	CONFIG6H	WRTD	WRTB	WRTC	—	—	—	—	—
30000Ch	CONFIG7L	—	—	—	—	EBTR3 ⁽¹⁾	EBTR2	EBTR1	EBTR0
30000Dh	CONFIG7H	—	EBTRB	—	—	—	—	—	—

Legend: Shaded cells are unimplemented.

Note 1: Unimplemented in PIC18FX525 devices.

24.4.1 PROGRAM MEMORY CODE PROTECTION

The user memory may be read to or written from any location using the table read and table write instructions. The Device ID register may be read with table reads. The Configuration registers may be read and written with the table read and table write instructions.

In user mode, the CPn bits have no direct effect. CPn bits inhibit external reads and writes. A block of user memory may be protected from table writes if the WRTn configuration bit is '0'. The EBTRn bits control table reads. For a block of user memory with the EBTRn bit set to '0', a table read instruction that executes from within that block is allowed to read. A

table read instruction that executes from a location outside of that block is not allowed to read and will result in reading '0's. Figures 24-4 through 24-6 illustrate table write and table read protection.

Note: Code protection bits may only be written to a '0' from a '1' state. It is not possible to write a '1' to a bit in the '0' state. Code protection bits are only set to '1' by a full chip erase or block erase function. The full chip erase and block erase functions can only be initiated via ICSP or an external programmer.

PIC18F6525/6621/8525/8621

FIGURE 24-4: TABLE WRITE (WRTn) DISALLOWED

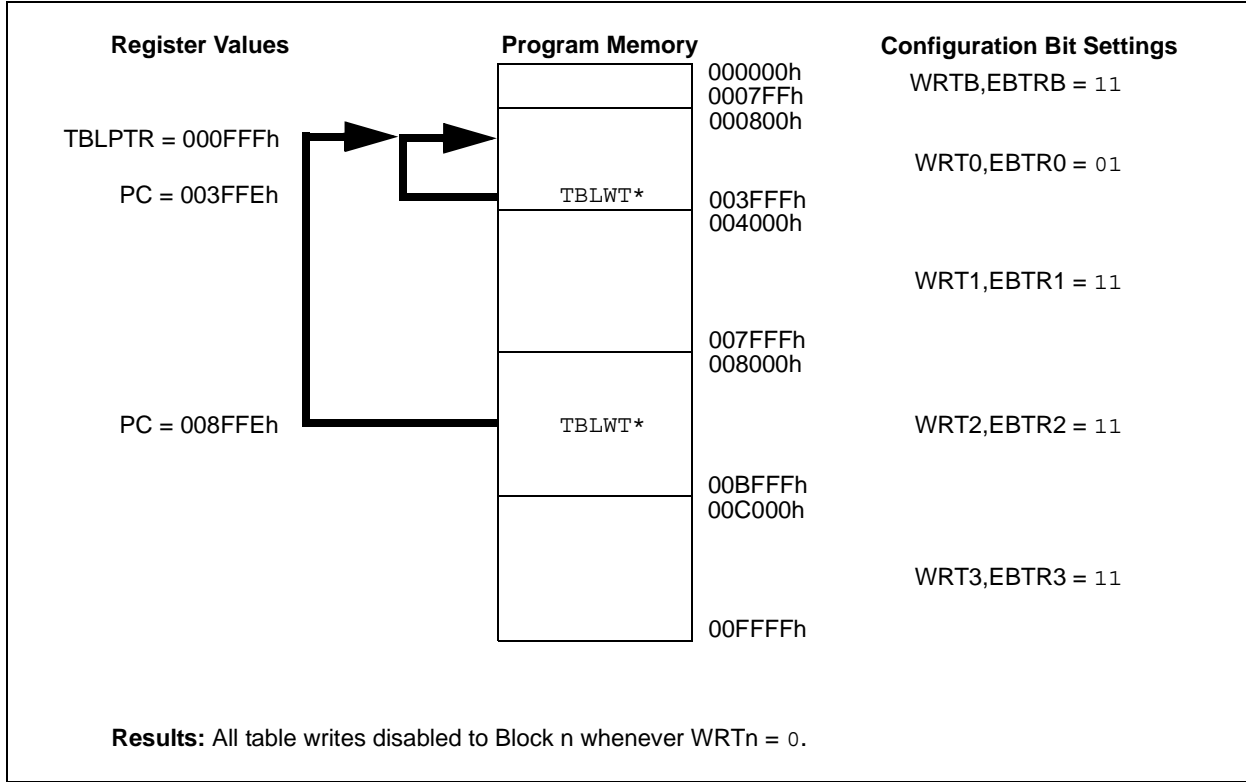
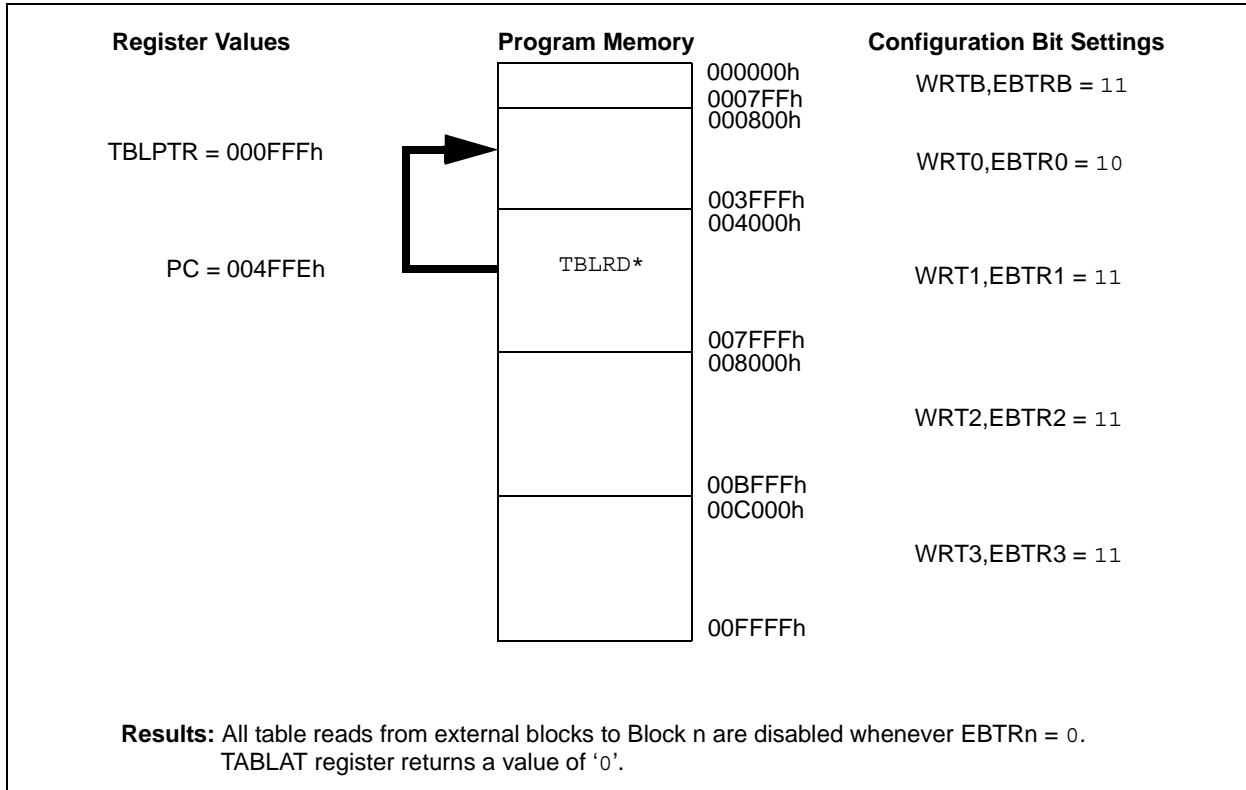
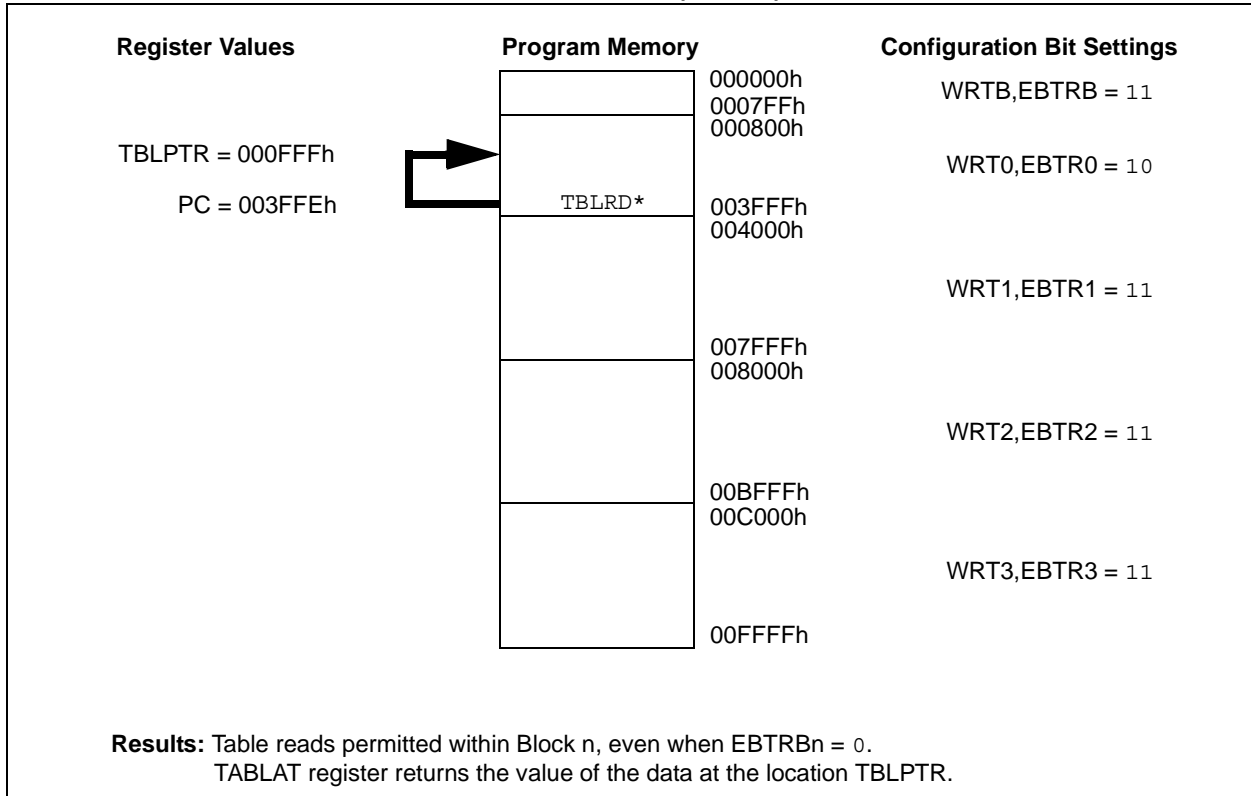

FIGURE 24-5: EXTERNAL BLOCK TABLE READ (EBTRn) DISALLOWED



PIC18F6525/6621/8525/8621

FIGURE 24-6: EXTERNAL BLOCK TABLE READ (EBTRn) ALLOWED



24.4.2 DATA EEPROM CODE PROTECTION

The entire data EEPROM is protected from external reads and writes by two bits: CPD and WRD. CPD inhibits external reads and writes of data EEPROM. WRD inhibits external writes to data EEPROM. The CPU can continue to read data EEPROM regardless of the protection bit settings.

24.4.3 CONFIGURATION REGISTER PROTECTION

The Configuration registers can be write-protected. The WRTC bit controls protection of the Configuration registers. In user mode, the WRTC bit is readable only. WRTC can only be written via ICSP or an external programmer.

PIC18F6525/6621/8525/8621

24.5 ID Locations

Eight memory locations (200000h-200007h) are designated as ID locations where the user can store checksum or other code identification numbers. These locations are accessible during normal execution through the TBLRD and TBLWT instructions, or during program/verify. The ID locations can be read when the device is code-protected.

24.6 In-Circuit Serial Programming™ (ICSP™)

PIC18F6525/6621/8525/8621 microcontrollers can be serially programmed while in the end application circuit. This is simply done with two lines for clock and data and three other lines for power, ground and the programming voltage. This allows customers to manufacture boards with unprogrammed devices and then program the microcontroller just before shipping the product. This also allows the most recent firmware or a custom firmware to be programmed.

24.7 In-Circuit Debugger

When the DEBUG bit in Configuration register, CONFIG4L, is programmed to a '0', the in-circuit debugger functionality is enabled. This function allows simple debugging functions when used with MPLAB® IDE. When the microcontroller has this feature enabled, some of the resources are not available for general use. Table 24-4 shows which features are consumed by the background debugger.

TABLE 24-4: DEBUGGER RESOURCES

I/O pins	RB6, RB7
Stack	2 levels
Program Memory	512 bytes
Data Memory	10 bytes

To use the in-circuit debugger function of the microcontroller, the design must implement In-Circuit Serial Programming connections to MCLR/VPP, VDD, GND, RB7 and RB6. This will interface to the in-circuit debugger module available from Microchip or one of the third party development tool companies.

24.8 Low-Voltage ICSP Programming

The LVP bit in Configuration register, CONFIG4L, enables Low-Voltage ICSP programming. This mode allows the microcontroller to be programmed via ICSP using a VDD source in the operating voltage range. This only means that VPP does not have to be brought to VIH, but can instead be left at the normal operating voltage. In this mode, the RB5/KBI1/PGM pin is dedicated to the programming function and ceases to be a general purpose I/O pin. During programming, VDD is applied to the MCLR/VPP pin. To enter Programming mode, VDD must be applied to the RB5/KBI1/PGM pin provided the LVP bit is set. The LVP bit defaults to a '1' from the factory.

- Note 1:** The High-Voltage Programming mode is always available, regardless of the state of the LVP bit, by applying VIH to the MCLR pin.
- 2: While in Low-Voltage ICSP mode, the RB5 pin can no longer be used as a general purpose I/O pin and should be held low during normal operation.
 - 3: When using Low-Voltage ICSP Programming (LVP) and the pull-ups on PORTB are enabled, bit 5 in the TRISB register must be cleared to disable the pull-up on RB5 and ensure the proper operation of the device.
 - 4: If the device Master Clear is disabled, verify that either of the following is done to ensure proper entry into ICSP mode:
 - a.) disable Low-Voltage Programming (CONFIG4L<2> = 0); or
 - b.) make certain that RB5/KBI1/PGM is held low during entry into ICSP.

If Low-Voltage Programming mode is not used, the LVP bit can be programmed to a '0' and RB5/KBI1/PGM becomes a digital I/O pin. However, the LVP bit may only be programmed when programming is entered with VIH on MCLR/VPP.

It should be noted that once the LVP bit is programmed to '0', only the High-Voltage Programming mode is available and only High-Voltage Programming mode can be used to program the device.

When using Low-Voltage ICSP, the part must be supplied 4.5V to 5.5V if a bulk erase will be executed. This includes reprogramming of the code-protect bits from an on-state to off-state. For all other cases of Low-Voltage ICSP, the part may be programmed at the normal operating voltage. This means unique user IDs or user code can be reprogrammed or added.

25.0 INSTRUCTION SET SUMMARY

The PIC18 instruction set adds many enhancements to the previous PICmicro® instruction sets, while maintaining an easy migration from these PICmicro instruction sets.

Most instructions are a single program memory word (16 bits), but there are three instructions that require two program memory locations.

Each single-word instruction is a 16-bit word divided into an opcode, which specifies the instruction type and one or more operands, which further specify the operation of the instruction.

The instruction set is highly orthogonal and is grouped into four basic categories:

- **Byte-oriented** operations
- **Bit-oriented** operations
- **Literal** operations
- **Control** operations

The PIC18 instruction set summary in Table 25-2 lists **byte-oriented**, **bit-oriented**, **literal** and **control** operations. Table 25-1 shows the opcode field descriptions.

Most **byte-oriented** instructions have three operands:

1. The file register (specified by 'f')
2. The destination of the result (specified by 'd')
3. The accessed memory (specified by 'a')

The file register designator 'f' specifies which file register is to be used by the instruction.

The destination designator 'd' specifies where the result of the operation is to be placed. If 'd' is zero, the result is placed in the WREG register. If 'd' is one, the result is placed in the file register specified in the instruction.

All **bit-oriented** instructions have three operands:

1. The file register (specified by 'f')
2. The bit in the file register (specified by 'b')
3. The accessed memory (specified by 'a')

The bit field designator 'b' selects the number of the bit affected by the operation, while the file register designator 'f' represents the number of the file in which the bit is located.

The **literal** instructions may use some of the following operands:

- A literal value to be loaded into a file register (specified by 'k')
- The desired FSR register to load the literal value into (specified by 'f')
- No operand required (specified by '—')

The **control** instructions may use some of the following operands:

- A program memory address (specified by 'n')
- The mode of the call or return instructions (specified by 's')
- The mode of the table read and table write instructions (specified by 'm')
- No operand required (specified by '—')

All instructions are a single word, except for three double-word instructions. These three instructions were made double-word instructions so that all the required information is available in these 32 bits. In the second word, the 4 MSBs are '1's. If this second word is executed as an instruction (by itself), it will execute as a NOP.

All single-word instructions are executed in a single instruction cycle unless a conditional test is true, or the program counter is changed as a result of the instruction. In these cases, the execution takes two instruction cycles with the additional instruction cycle(s) executed as a NOP.

The double-word instructions execute in two instruction cycles.

One instruction cycle consists of four oscillator periods. Thus, for an oscillator frequency of 4 MHz, the normal instruction execution time is 1 μ s. If a conditional test is true or the program counter is changed as a result of an instruction, the instruction execution time is 2 μ s. Two-word branch instructions (if true) would take 3 μ s.

Figure 25-1 shows the general formats that the instructions can have.

All examples use the format 'nnh' to represent a hexadecimal number, where 'h' signifies a hexadecimal digit.

The Instruction Set Summary, shown in Table 25-2, lists the instructions recognized by the Microchip MPASM™ Assembler.

Section 25.1 "Instruction Set" provides a description of each instruction.

PIC18F6525/6621/8525/8621

TABLE 25-1: OPCODE FIELD DESCRIPTIONS

Field	Description
a	RAM access bit a = 0: RAM location in Access RAM (BSR register is ignored) a = 1: RAM bank is specified by BSR register
bbb	Bit address within an 8-bit file register (0 to 7).
BSR	Bank Select Register. Used to select the current RAM bank.
d	Destination select bit d = 0: store result in WREG d = 1: store result in file register f
dest	Destination either the WREG register or the specified register file location.
f	8-bit register file address (0x00 to 0xFF).
fs	12-bit register file address (0x000 to 0xFFF). This is the source address.
fd	12-bit register file address (0x000 to 0xFFF). This is the destination address.
k	Literal field, constant data or label (may be either an 8-bit, 12-bit or a 20-bit value).
label	Label name.
mmm	The mode of the TBLPTR register for the table read and table write instructions. Only used with table read and table write instructions:
*	No change to register (such as TBLPTR with table reads and writes)
*+	Post-Increment register (such as TBLPTR with table reads and writes)
*-	Post-Decrement register (such as TBLPTR with table reads and writes)
+*	Pre-Increment register (such as TBLPTR with table reads and writes)
n	The relative address (2's complement number) for relative branch instructions, or the direct address for call/branch and return instructions.
PRODH	Product of Multiply High Byte.
PRODL	Product of Multiply Low Byte.
s	Fast Call/Return mode select bit s = 0: do not update into/from shadow registers s = 1: certain registers loaded into/from shadow registers (Fast mode)
u	Unused or unchanged.
WREG	Working register (accumulator).
x	Don't care ('0' or '1') The assembler will generate code with x = 0. It is the recommended form of use for compatibility with all Microchip software tools.
TBLPTR	21-bit Table Pointer (points to a Program Memory location).
TABLAT	8-bit Table Latch.
TOS	Top-of-Stack.
PC	Program Counter.
PCL	Program Counter Low Byte.
PCH	Program Counter High Byte.
PCLATH	Program Counter High Byte Latch.
PCLATU	Program Counter Upper Byte Latch.
GIE	Global Interrupt Enable bit.
WDT	Watchdog Timer.
T \bar{O}	Time-out bit.
P \bar{D}	Power-down bit.
C, DC, Z, OV, N	ALU Status bits: Carry, Digit Carry, Zero, Overflow, Negative.
[]	Optional.
()	Contents.
→	Assigned to.
< >	Register bit field.
∈	In the set of.
<i>italics</i>	User defined term (font is courier).

PIC18F6525/6621/8525/8621

FIGURE 25-1: GENERAL FORMAT FOR INSTRUCTIONS

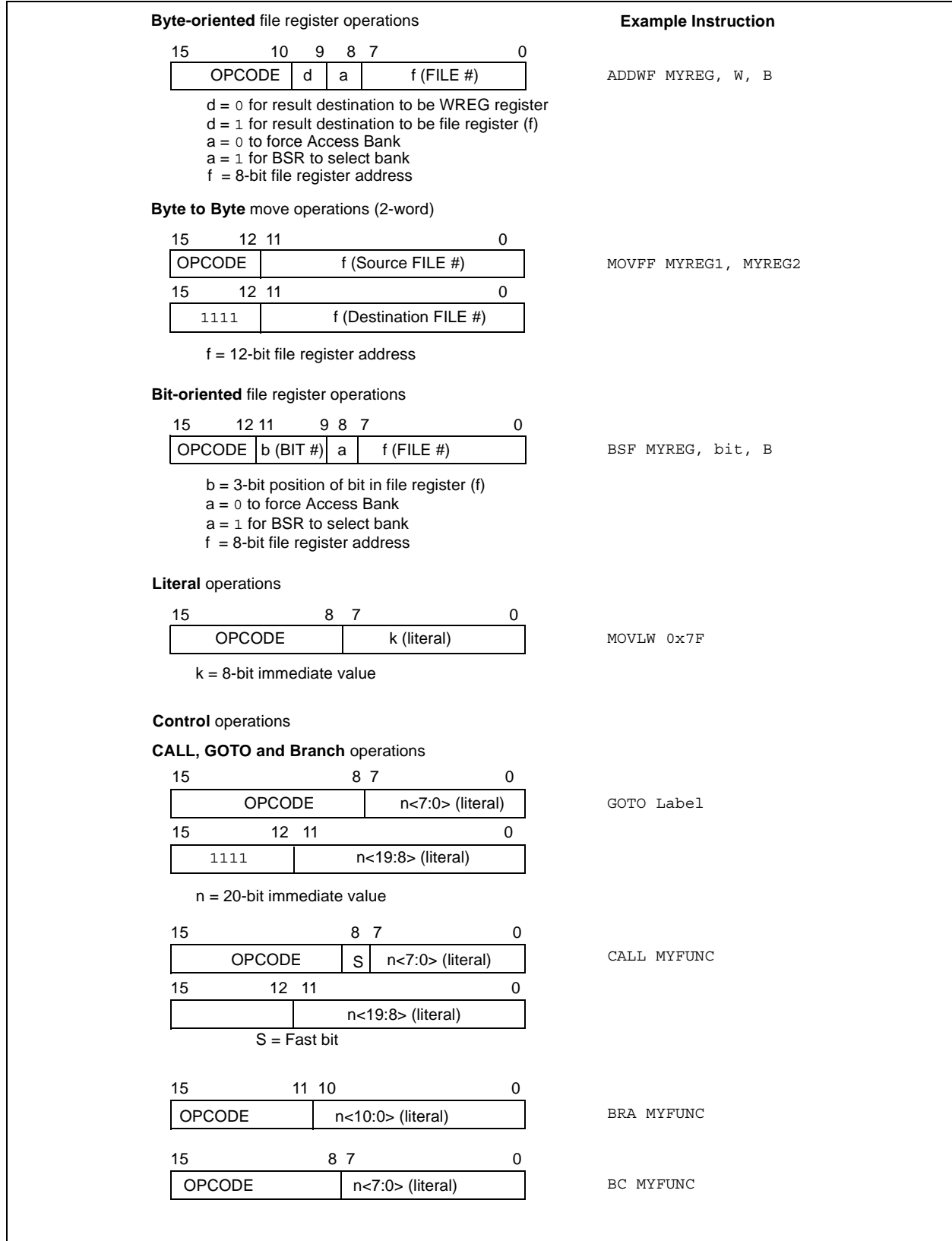

PIC18F6525/6621/8525/8621

TABLE 25-2: PIC18FXXXX INSTRUCTION SET

Mnemonic, Operands	Description	Cycles	16-Bit Instruction Word				Status Affected	Notes	
			MSb			LSb			
BYTE-ORIENTED FILE REGISTER OPERATIONS									
ADDWF	f, d, a	Add WREG and f	1	0010	01da	ffff	ffff	C, DC, Z, OV, N	1, 2
ADDWFC	f, d, a	Add WREG and Carry bit to f	1	0010	00da	ffff	ffff	C, DC, Z, OV, N	1, 2
ANDWF	f, d, a	AND WREG with f	1	0001	01da	ffff	ffff	Z, N	1, 2
CLRF	f, a	Clear f	1	0110	101a	ffff	ffff	Z	2
COMF	f, d, a	Complement f	1	0001	11da	ffff	ffff	Z, N	1, 2
CPFSEQ	f, a	Compare f with WREG, skip =	1 (2 or 3)	0110	001a	ffff	ffff	None	4
CPFSGT	f, a	Compare f with WREG, skip >	1 (2 or 3)	0110	010a	ffff	ffff	None	4
CPFSLT	f, a	Compare f with WREG, skip <	1 (2 or 3)	0110	000a	ffff	ffff	None	1, 2
DECF	f, d, a	Decrement f	1	0000	01da	ffff	ffff	C, DC, Z, OV, N	1, 2, 3, 4
DECFSZ	f, d, a	Decrement f, Skip if 0	1 (2 or 3)	0010	11da	ffff	ffff	None	1, 2, 3, 4
DCFSNZ	f, d, a	Decrement f, Skip if Not 0	1 (2 or 3)	0100	11da	ffff	ffff	None	1, 2
INCF	f, d, a	Increment f	1	0010	10da	ffff	ffff	C, DC, Z, OV, N	1, 2, 3, 4
INCFSZ	f, d, a	Increment f, Skip if 0	1 (2 or 3)	0011	11da	ffff	ffff	None	4
INFSNZ	f, d, a	Increment f, Skip if Not 0	1 (2 or 3)	0100	10da	ffff	ffff	None	1, 2
IORWF	f, d, a	Inclusive OR WREG with f	1	0001	00da	ffff	ffff	Z, N	1, 2
MOVF	f, d, a	Move f	1	0101	00da	ffff	ffff	Z, N	1
MOVFF	f _s , f _d	Move f _s (source) to 1st word f _d (destination) 2nd word	2	1100	ffff	ffff	ffff	None	
MOVWF	f, a	Move WREG to f	1	0110	111a	ffff	ffff	None	
MULWF	f, a	Multiply WREG with f	1	0000	001a	ffff	ffff	None	
NEGF	f, a	Negate f	1	0110	110a	ffff	ffff	C, DC, Z, OV, N	1, 2
RLCF	f, d, a	Rotate Left f through Carry	1	0011	01da	ffff	ffff	C, Z, N	
RLNCF	f, d, a	Rotate Left f (No Carry)	1	0100	01da	ffff	ffff	Z, N	1, 2
RRCF	f, d, a	Rotate Right f through Carry	1	0011	00da	ffff	ffff	C, Z, N	
RRNCF	f, d, a	Rotate Right f (No Carry)	1	0100	00da	ffff	ffff	Z, N	
SETF	f, a	Set f	1	0110	100a	ffff	ffff	None	
SUBFWB	f, d, a	Subtract f from WREG with borrow	1	0101	01da	ffff	ffff	C, DC, Z, OV, N	1, 2
SUBWF	f, d, a	Subtract WREG from f	1	0101	11da	ffff	ffff	C, DC, Z, OV, N	
SUBWFB	f, d, a	Subtract WREG from f with borrow	1	0101	10da	ffff	ffff	C, DC, Z, OV, N	1, 2
SWAPF	f, d, a	Swap nibbles in f	1	0011	10da	ffff	ffff	None	4
TSTFSZ	f, a	Test f, skip if 0	1 (2 or 3)	0110	011a	ffff	ffff	None	1, 2
XORWF	f, d, a	Exclusive OR WREG with f	1	0001	10da	ffff	ffff	Z, N	
BIT-ORIENTED FILE REGISTER OPERATIONS									
BCF	f, b, a	Bit Clear f	1	1001	bbba	ffff	ffff	None	1, 2
BSF	f, b, a	Bit Set f	1	1000	bbba	ffff	ffff	None	1, 2
BTFSC	f, b, a	Bit Test f, Skip if Clear	1 (2 or 3)	1011	bbba	ffff	ffff	None	3, 4
BTFSS	f, b, a	Bit Test f, Skip if Set	1 (2 or 3)	1010	bbba	ffff	ffff	None	3, 4
BTG	f, b, a	Bit Toggle f	1	0111	bbba	ffff	ffff	None	1, 2

Note 1: When a Port register is modified as a function of itself (e.g., MOVF PORTB, 1, 0), the value used will be that value present on the pins themselves. For example, if the data latch is '1' for a pin configured as an input and is driven low by an external device, the data will be written back with a '0'.

- If this instruction is executed on the TMR0 register (and where applicable, 'd' = 1), the prescaler will be cleared if assigned.
- If Program Counter (PC) is modified or a conditional test is true, the instruction requires two cycles. The second cycle is executed as a NOP.
- Some instructions are 2-word instructions. The second word of these instructions will be executed as a NOP unless the first word of the instruction retrieves the information embedded in these 16 bits. This ensures that all program memory locations have a valid instruction.
- If the table write starts the write cycle to internal memory, the write will continue until terminated.

PIC18F6525/6621/8525/8621

TABLE 25-2: PIC18FXXXX INSTRUCTION SET (CONTINUED)

Mnemonic, Operands	Description	Cycles	16-Bit Instruction Word				Status Affected	Notes	
			MSb			LSb			
CONTROL OPERATIONS									
BC	n	Branch if Carry	1 (2)	1110	0010	nnnn	nnnn	None	
BN	n	Branch if Negative	1 (2)	1110	0110	nnnn	nnnn	None	
BNC	n	Branch if Not Carry	1 (2)	1110	0011	nnnn	nnnn	None	
BNN	n	Branch if Not Negative	1 (2)	1110	0111	nnnn	nnnn	None	
BNOV	n	Branch if Not Overflow	1 (2)	1110	0101	nnnn	nnnn	None	
BNZ	n	Branch if Not Zero	2	1110	0001	nnnn	nnnn	None	
BOV	n	Branch if Overflow	1 (2)	1110	0100	nnnn	nnnn	None	
BRA	n	Branch Unconditionally	1 (2)	1101	0nnn	nnnn	nnnn	None	
BZ	n	Branch if Zero	1 (2)	1110	0000	nnnn	nnnn	None	
CALL	n, s	Call subroutine 1st word 2nd word	2	1110	110s	kkkk	kkkk	None	
CLRWDT	—	Clear Watchdog Timer	1	0000	0000	0000	0100	$\overline{TO}, \overline{PD}$	
DAW	—	Decimal Adjust WREG	1	0000	0000	0000	0111	C	
GOTO	n	Go to address 1st word 2nd word	2	1110	1111	kkkk	kkkk	None	
NOP	—	No Operation	1	0000	0000	0000	0000	None	
NOP	—	No Operation	1	1111	xxxx	xxxx	xxxx	None	4
POP	—	Pop top of return stack (TOS)	1	0000	0000	0000	0110	None	
PUSH	—	Push top of return stack (TOS)	1	0000	0000	0000	0101	None	
RCALL	n	Relative Call	2	1101	1nnn	nnnn	nnnn	None	
RESET	—	Software device Reset	1	0000	0000	1111	1111	All	
RETFIE	s	Return from interrupt enable	2	0000	0000	0001	000s	GIE/GIEH, PEIE/GIEL	
RETLW	k	Return with literal in WREG	2	0000	1100	kkkk	kkkk	None	
RETURN	s	Return from Subroutine	2	0000	0000	0001	001s	None	
SLEEP	—	Go into Standby mode	1	0000	0000	0000	0011	$\overline{TO}, \overline{PD}$	

Note 1: When a Port register is modified as a function of itself (e.g., `MOVF PORTB, 1, 0`), the value used will be that value present on the pins themselves. For example, if the data latch is '1' for a pin configured as an input and is driven low by an external device, the data will be written back with a '0'.

- 2: If this instruction is executed on the TMR0 register (and where applicable, 'd' = 1), the prescaler will be cleared if assigned.
- 3: If Program Counter (PC) is modified or a conditional test is true, the instruction requires two cycles. The second cycle is executed as a NOP.
- 4: Some instructions are 2-word instructions. The second word of these instructions will be executed as a NOP unless the first word of the instruction retrieves the information embedded in these 16 bits. This ensures that all program memory locations have a valid instruction.
- 5: If the table write starts the write cycle to internal memory, the write will continue until terminated.

PIC18F6525/6621/8525/8621

TABLE 25-2: PIC18FXXXX INSTRUCTION SET (CONTINUED)

Mnemonic, Operands	Description	Cycles	16-Bit Instruction Word				Status Affected	Notes	
			MSb			LSb			
LITERAL OPERATIONS									
ADDLW	k	Add literal and WREG	1	0000	1111	kkkk	kkkk	C, DC, Z, OV, N	
ANDLW	k	AND literal with WREG	1	0000	1011	kkkk	kkkk	Z, N	
IORLW	k	Inclusive OR literal with WREG	1	0000	1001	kkkk	kkkk	Z, N	
LFSR	f, k	Move literal (12-bit) 2nd word to FSRx 1st word	2	1110	1110	00ff	kkkk	None	
MOVLB	k	Move literal to BSR<3:0>	1	0000	0001	0000	kkkk	None	
MOVLW	k	Move literal to WREG	1	0000	1110	kkkk	kkkk	None	
MULLW	k	Multiply literal with WREG	1	0000	1101	kkkk	kkkk	None	
RETLW	k	Return with literal in WREG	2	0000	1100	kkkk	kkkk	None	
SUBLW	k	Subtract WREG from literal	1	0000	1000	kkkk	kkkk	C, DC, Z, OV, N	
XORLW	k	Exclusive OR literal with WREG	1	0000	1010	kkkk	kkkk	Z, N	
DATA MEMORY ↔ PROGRAM MEMORY OPERATIONS									
TBLRD*		Table Read	2	0000	0000	0000	1000	None	
TBLRD*+		Table Read with post-increment		0000	0000	0000	1001	None	
TBLRD*-		Table Read with post-decrement		0000	0000	0000	1010	None	
TBLRD+*		Table Read with pre-increment		0000	0000	0000	1011	None	
TBLWT*		Table Write	2 (5)	0000	0000	0000	1100	None	
TBLWT*+		Table Write with post-increment		0000	0000	0000	1101	None	
TBLWT*-		Table Write with post-decrement		0000	0000	0000	1110	None	
TBLWT+*		Table Write with pre-increment		0000	0000	0000	1111	None	

- Note 1:** When a Port register is modified as a function of itself (e.g., `MOVF PORTB, 1, 0`), the value used will be that value present on the pins themselves. For example, if the data latch is '1' for a pin configured as an input and is driven low by an external device, the data will be written back with a '0'.
- If this instruction is executed on the TMR0 register (and where applicable, 'd' = 1), the prescaler will be cleared if assigned.
 - If Program Counter (PC) is modified or a conditional test is true, the instruction requires two cycles. The second cycle is executed as a NOP.
 - Some instructions are 2-word instructions. The second word of these instructions will be executed as a NOP unless the first word of the instruction retrieves the information embedded in these 16 bits. This ensures that all program memory locations have a valid instruction.
 - If the table write starts the write cycle to internal memory, the write will continue until terminated.

PIC18F6525/6621/8525/8621

25.1 Instruction Set

ADDLW Add Literal to W

Syntax: [*label*] ADDLW k

Operands: $0 \leq k \leq 255$

Operation: $(W) + k \rightarrow W$

Status Affected: N, OV, C, DC, Z

Encoding:

0000	1111	kkkk	kkkk
------	------	------	------

Description: The contents of W are added to the 8-bit literal 'k' and the result is placed in W.

Words: 1

Cycles: 1

Q Cycle Activity:

Q1	Q2	Q3	Q4
Decode	Read literal 'k'	Process Data	Write to W

Example: ADDLW 0x15

Before Instruction
W = 0x10

After Instruction
W = 0x25

ADDWF Add W to f

Syntax: [*label*] ADDWF f [,d [,a] f [,d [,a]

Operands: $0 \leq f \leq 255$
 $d \in [0,1]$
 $a \in [0,1]$

Operation: $(W) + (f) \rightarrow \text{dest}$

Status Affected: N, OV, C, DC, Z

Encoding:

0010	01da	ffff	ffff
------	------	------	------

Description: Add W to register 'f'. If 'd' is '0', the result is stored in W. If 'd' is '1', the result is stored back in register 'f' (default). If 'a' is '0', the Access Bank will be selected. If 'a' is '1', the BSR is used.

Words: 1

Cycles: 1

Q Cycle Activity:

Q1	Q2	Q3	Q4
Decode	Read register 'f'	Process Data	Write to destination

Example: ADDWF REG, 0, 0

Before Instruction
W = 0x17
REG = 0xC2

After Instruction
W = 0xD9
REG = 0xC2

PIC18F6525/6621/8525/8621

ADDWFC Add W and Carry bit to f

Syntax: [*label*] ADDWFC f [,d [,a]]

Operands: $0 \leq f \leq 255$
 $d \in [0,1]$
 $a \in [0,1]$

Operation: $(W) + (f) + (C) \rightarrow \text{dest}$

Status Affected: N, OV, C, DC, Z

Encoding:

0010	00da	ffff	ffff
------	------	------	------

Description: Add W, the Carry flag and data memory location 'f'. If 'd' is '0', the result is placed in W. If 'd' is '1', the result is placed in data memory location 'f'. If 'a' is '0', the Access Bank will be selected. If 'a' is '1', the BSR will not be overridden.

Words: 1

Cycles: 1

Q Cycle Activity:

Q1	Q2	Q3	Q4
Decode	Read register 'f'	Process Data	Write to destination

Example: ADDWFC REG, 0, 1

Before Instruction
 Carry bit = 1
 REG = 0x02
 W = 0x4D

After Instruction
 Carry bit = 0
 REG = 0x02
 W = 0x50

ANDLW AND Literal with W

Syntax: [*label*] ANDLW k

Operands: $0 \leq k \leq 255$

Operation: $(W) \text{ .AND. } k \rightarrow W$

Status Affected: N, Z

Encoding:

0000	1011	kkkk	kkkk
------	------	------	------

Description: The contents of W are ANDed with the 8-bit literal 'k'. The result is placed in W.

Words: 1

Cycles: 1

Q Cycle Activity:

Q1	Q2	Q3	Q4
Decode	Read literal 'k'	Process Data	Write to W

Example: ANDLW 0x5F

Before Instruction
 W = 0xA3

After Instruction
 W = 0x03

PIC18F6525/6621/8525/8621

ANDWF

AND W with f

Syntax: `[label] ANDWF f [d [,a]]`

Operands: $0 \leq f \leq 255$
 $d \in [0,1]$
 $a \in [0,1]$

Operation: (W) .AND. (f) → dest

Status Affected: N, Z

Encoding:

0001	01da	ffff	ffff
------	------	------	------

Description: The contents of W are ANDed with register 'f'. If 'd' is '0', the result is stored in W. If 'd' is '1', the result is stored back in register 'd' (default). If 'a' is '0', the Access Bank will be selected. If 'a' is '1', the BSR will not be overridden (default).

Words: 1

Cycles: 1

Q Cycle Activity:

Q1	Q2	Q3	Q4
Decode	Read register 'f'	Process Data	Write to destination

Example: `ANDWF REG, 0, 0`

Before Instruction

W = 0x17
 REG = 0xC2

After Instruction

W = 0x02
 REG = 0xC2

BC

Branch if Carry

Syntax: `[label] BC n`

Operands: $-128 \leq n \leq 127$

Operation: if Carry bit is '1'
 $(PC) + 2 + 2n \rightarrow PC$

Status Affected: None

Encoding:

1110	0010	nnnn	nnnn
------	------	------	------

Description: If the Carry bit is '1', then the program will branch. The 2's complement number '2n' is added to the PC. Since the PC will have incremented to fetch the next instruction, the new address will be $PC + 2 + 2n$. This instruction is then a two-cycle instruction.

Words: 1

Cycles: 1(2)

Q Cycle Activity:

If Jump:

Q1	Q2	Q3	Q4
Decode	Read literal 'n'	Process Data	Write to PC
No operation	No operation	No operation	No operation

If No Jump:

Q1	Q2	Q3	Q4
Decode	Read literal 'n'	Process Data	No operation

Example: `HERE BC 5`

Before Instruction

PC = address (HERE)

After Instruction

If Carry = 1;
 PC = address (HERE + 12)
 If Carry = 0;
 PC = address (HERE + 2)

PIC18F6525/6621/8525/8621

BCF Bit Clear f

Syntax: [*label*] BCF f,b[,a]

Operands: $0 \leq f \leq 255$
 $0 \leq b \leq 7$
 $a \in [0,1]$

Operation: $0 \rightarrow f < b >$

Status Affected: None

Encoding:

1001	bbba	ffff	ffff
------	------	------	------

Description: Bit 'b' in register 'f' is cleared. If 'a' is '0', the Access Bank will be selected, overriding the BSR value. If 'a' = 1, then the bank will be selected as per the BSR value (default).

Words: 1

Cycles: 1

Q Cycle Activity:

Q1	Q2	Q3	Q4
Decode	Read register 'f'	Process Data	Write register 'f'

Example: BCF FLAG_REG, 7, 0

Before Instruction
 FLAG_REG = 0xC7

After Instruction
 FLAG_REG = 0x47

BN Branch if Negative

Syntax: [*label*] BN n

Operands: $-128 \leq n \leq 127$

Operation: if Negative bit is '1'
 $(PC) + 2 + 2n \rightarrow PC$

Status Affected: None

Encoding:

1110	0110	nnnn	nnnn
------	------	------	------

Description: If the Negative bit is '1', then the program will branch. The 2's complement number '2n' is added to the PC. Since the PC will have incremented to fetch the next instruction, the new address will be $PC + 2 + 2n$. This instruction is then a two-cycle instruction.

Words: 1

Cycles: 1(2)

Q Cycle Activity:

If Jump:

Q1	Q2	Q3	Q4
Decode	Read literal 'n'	Process Data	Write to PC
No operation	No operation	No operation	No operation

If No Jump:

Q1	Q2	Q3	Q4
Decode	Read literal 'n'	Process Data	No operation

Example: HERE BN Jump

Before Instruction
 PC = address (HERE)

After Instruction
 If Negative = 1;
 PC = address (Jump)
 If Negative = 0;
 PC = address (HERE + 2)

PIC18F6525/6621/8525/8621

BNC **Branch if Not Carry**

Syntax: [*label*] BNC n

Operands: -128 ≤ n ≤ 127

Operation: if Carry bit is '0'
 (PC) + 2 + 2n → PC

Status Affected: None

Encoding:

1110	0011	nnnn	nnnn
------	------	------	------

Description: If the Carry bit is '0', then the program will branch.
 The 2's complement number '2n' is added to the PC. Since the PC will have incremented to fetch the next instruction, the new address will be PC + 2 + 2n. This instruction is then a two-cycle instruction.

Words: 1

Cycles: 1(2)

Q Cycle Activity:
If Jump:

Q1	Q2	Q3	Q4
Decode	Read literal 'n'	Process Data	Write to PC
No operation	No operation	No operation	No operation

If No Jump:

Q1	Q2	Q3	Q4
Decode	Read literal 'n'	Process Data	No operation

Example: HERE BNC Jump

Before Instruction
PC = address (HERE)

After Instruction
If Carry = 0;
PC = address (Jump)
If Carry = 1;
PC = address (HERE + 2)

BNN **Branch if Not Negative**

Syntax: [*label*] BNN n

Operands: -128 ≤ n ≤ 127

Operation: if Negative bit is '0'
 (PC) + 2 + 2n → PC

Status Affected: None

Encoding:

1110	0111	nnnn	nnnn
------	------	------	------

Description: If the Negative bit is '0', then the program will branch.
 The 2's complement number '2n' is added to the PC. Since the PC will have incremented to fetch the next instruction, the new address will be PC + 2 + 2n. This instruction is then a two-cycle instruction.

Words: 1

Cycles: 1(2)

Q Cycle Activity:
If Jump:

Q1	Q2	Q3	Q4
Decode	Read literal 'n'	Process Data	Write to PC
No operation	No operation	No operation	No operation

If No Jump:

Q1	Q2	Q3	Q4
Decode	Read literal 'n'	Process Data	No operation

Example: HERE BNN Jump

Before Instruction
PC = address (HERE)

After Instruction
If Negative = 0;
PC = address (Jump)
If Negative = 1;
PC = address (HERE + 2)

PIC18F6525/6621/8525/8621

BNOV Branch if Not Overflow

Syntax: [*label*] BNOV n

Operands: $-128 \leq n \leq 127$

Operation: if Overflow bit is '0'
(PC) + 2 + 2n → PC

Status Affected: None

Encoding:

1110	0101	nnnn	nnnn
------	------	------	------

Description: If the Overflow bit is '0', then the program will branch. The 2's complement number '2n' is added to the PC. Since the PC will have incremented to fetch the next instruction, the new address will be PC + 2 + 2n. This instruction is then a two-cycle instruction.

Words: 1

Cycles: 1(2)

Q Cycle Activity:

If Jump:

Q1	Q2	Q3	Q4
Decode	Read literal 'n'	Process Data	Write to PC
No operation	No operation	No operation	No operation

If No Jump:

Q1	Q2	Q3	Q4
Decode	Read literal 'n'	Process Data	No operation

Example: HERE BNOV Jump

Before Instruction
PC = address (HERE)

After Instruction
If Overflow = 0;
PC = address (Jump)
If Overflow = 1;
PC = address (HERE + 2)

BNZ Branch if Not Zero

Syntax: [*label*] BNZ n

Operands: $-128 \leq n \leq 127$

Operation: if Zero bit is '0'
(PC) + 2 + 2n → PC

Status Affected: None

Encoding:

1110	0001	nnnn	nnnn
------	------	------	------

Description: If the Zero bit is '0', then the program will branch. The 2's complement number '2n' is added to the PC. Since the PC will have incremented to fetch the next instruction, the new address will be PC + 2 + 2n. This instruction is then a two-cycle instruction.

Words: 1

Cycles: 1(2)

Q Cycle Activity:

If Jump:

Q1	Q2	Q3	Q4
Decode	Read literal 'n'	Process Data	Write to PC
No operation	No operation	No operation	No operation

If No Jump:

Q1	Q2	Q3	Q4
Decode	Read literal 'n'	Process Data	No operation

Example: HERE BNZ Jump

Before Instruction
PC = address (HERE)

After Instruction
If Zero = 0;
PC = address (Jump)
If Zero = 1;
PC = address (HERE + 2)

PIC18F6525/6621/8525/8621

BRA Unconditional Branch

Syntax: [*label*] BRA n

Operands: $-1024 \leq n \leq 1023$

Operation: $(PC) + 2 + 2n \rightarrow PC$

Status Affected: None

Encoding:

1101	0nnn	nnnn	nnnn
------	------	------	------

Description: Add the 2's complement number '2n' to the PC. Since the PC will have incremented to fetch the next instruction, the new address will be $PC + 2 + 2n$. This instruction is a two-cycle instruction.

Words: 1

Cycles: 2

Q Cycle Activity:

	Q1	Q2	Q3	Q4
Decode	Read literal 'n'	Process Data	Write to PC	
No operation	No operation	No operation	No operation	

Example: HERE BRA Jump

Before Instruction
PC = address (HERE)

After Instruction
PC = address (Jump)

BSF Bit Set f

Syntax: [*label*] BSF f,b[a]

Operands: $0 \leq f \leq 255$
 $0 \leq b \leq 7$
 $a \in [0,1]$

Operation: $1 \rightarrow f < b >$

Status Affected: None

Encoding:

1000	bbba	ffff	ffff
------	------	------	------

Description: Bit 'b' in register 'f' is set. If 'a' is '0', Access Bank will be selected, overriding the BSR value. If 'a' = 1, then the bank will be selected as per the BSR value.

Words: 1

Cycles: 1

Q Cycle Activity:

	Q1	Q2	Q3	Q4
Decode	Read register 'f'	Process Data	Write register 'f'	

Example: BSF FLAG_REG, 7, 1

Before Instruction
FLAG_REG = 0x0A

After Instruction
FLAG_REG = 0x8A

PIC18F6525/6621/8525/8621

BTFSC **Bit Test File, Skip if Clear**

Syntax: [*label*] BTFSC f,b[,a]

Operands: $0 \leq f \leq 255$
 $0 \leq b \leq 7$
 $a \in [0,1]$

Operation: skip if (f) = 0

Status Affected: None

Encoding:

1011	bbba	ffff	ffff
------	------	------	------

Description: If bit 'b' in register 'f' is '0', then the next instruction is skipped.
 If bit 'b' is '0', then the next instruction fetched during the current instruction execution is discarded and a NOP is executed instead, making this a two-cycle instruction. If 'a' is '0', the Access Bank will be selected, overriding the BSR value. If 'a' = 1, then the bank will be selected as per the BSR value (default).

Words: 1

Cycles: 1(2)
Note: 3 cycles if skip and followed by a 2-word instruction.

Q Cycle Activity:

Q1	Q2	Q3	Q4
Decode	Read register 'f'	Process Data	No operation

If skip:

Q1	Q2	Q3	Q4
No operation	No operation	No operation	No operation

If skip and followed by 2-word instruction:

Q1	Q2	Q3	Q4
No operation	No operation	No operation	No operation
No operation	No operation	No operation	No operation

Example: HERE BTFSC FLAG, 1, 0
 FALSE :
 TRUE :

Before Instruction
 PC = address (HERE)

After Instruction
 If FLAG<1> = 0;
 PC = address (TRUE)
 If FLAG<1> = 1;
 PC = address (FALSE)

BTFSS **Bit Test File, Skip if Set**

Syntax: [*label*] BTFSS f,b[,a]

Operands: $0 \leq f \leq 255$
 $0 \leq b < 7$
 $a \in [0,1]$

Operation: skip if (f) = 1

Status Affected: None

Encoding:

1010	bbba	ffff	ffff
------	------	------	------

Description: If bit 'b' in register 'f' is '1', then the next instruction is skipped.
 If bit 'b' is '1', then the next instruction fetched during the current instruction execution, is discarded and a NOP is executed instead, making this a two-cycle instruction. If 'a' is '0', the Access Bank will be selected, overriding the BSR value. If 'a' = 1, then the bank will be selected as per the BSR value (default).

Words: 1

Cycles: 1(2)
Note: 3 cycles if skip and followed by a 2-word instruction.

Q Cycle Activity:

Q1	Q2	Q3	Q4
Decode	Read register 'f'	Process Data	No operation

If skip:

Q1	Q2	Q3	Q4
No operation	No operation	No operation	No operation

If skip and followed by 2-word instruction:

Q1	Q2	Q3	Q4
No operation	No operation	No operation	No operation
No operation	No operation	No operation	No operation

Example: HERE BTFSS FLAG, 1, 0
 FALSE :
 TRUE :

Before Instruction
 PC = address (HERE)

After Instruction
 If FLAG<1> = 0;
 PC = address (FALSE)
 If FLAG<1> = 1;
 PC = address (TRUE)

PIC18F6525/6621/8525/8621

BTG

Bit Toggle f

Syntax: [label] BTG f,b[,a]

Operands: $0 \leq f \leq 255$
 $0 \leq b < 7$
 $a \in [0,1]$

Operation: $(\overline{f\langle b \rangle}) \rightarrow f\langle b \rangle$

Status Affected: None

Encoding:

0111	bbba	ffff	ffff
------	------	------	------

Description: Bit 'b' in data memory location 'f' is inverted. If 'a' is '0', the Access Bank will be selected, overriding the BSR value. If 'a' = 1, then the bank will be selected as per the BSR value (default).

Words: 1

Cycles: 1

Q Cycle Activity:

Q1	Q2	Q3	Q4
Decode	Read register 'f'	Process Data	Write register 'f'

Example: BTG PORTC, 4, 0

Before Instruction:

PORTC = 0111 0101 [0x75]

After Instruction:

PORTC = 0110 0101 [0x65]

BOV

Branch if Overflow

Syntax: [label] BOV n

Operands: $-128 \leq n \leq 127$

Operation: if Overflow bit is '1'
 $(PC) + 2 + 2n \rightarrow PC$

Status Affected: None

Encoding:

1110	0100	nnnn	nnnn
------	------	------	------

Description: If the Overflow bit is '1', then the program will branch. The 2's complement number '2n' is added to the PC. Since the PC will have incremented to fetch the next instruction, the new address will be $PC + 2 + 2n$. This instruction is then a two-cycle instruction.

Words: 1

Cycles: 1(2)

Q Cycle Activity:

If Jump:

Q1	Q2	Q3	Q4
Decode	Read literal 'n'	Process Data	Write to PC
No operation	No operation	No operation	No operation

If No Jump:

Q1	Q2	Q3	Q4
Decode	Read literal 'n'	Process Data	No operation

Example: HERE BOV Jump

Before Instruction

PC = address (HERE)

After Instruction

If Overflow = 1;

PC = address (Jump)

If Overflow = 0;

PC = address (HERE + 2)

PIC18F6525/6621/8525/8621

BZ Branch if Zero

Syntax: [label] BZ n

Operands: $-128 \leq n \leq 127$

Operation: if Zero bit is '1'
(PC) + 2 + 2n → PC

Status Affected: None

Encoding:

1110	0000	nnnn	nnnn
------	------	------	------

Description: If the Zero bit is '1', then the program will branch. The 2's complement number '2n' is added to the PC. Since the PC will have incremented to fetch the next instruction, the new address will be PC + 2 + 2n. This instruction is then a two-cycle instruction.

Words: 1

Cycles: 1(2)

Q Cycle Activity:
If Jump:

Q1	Q2	Q3	Q4
Decode	Read literal 'n'	Process Data	Write to PC
No operation	No operation	No operation	No operation

If No Jump:

Q1	Q2	Q3	Q4
Decode	Read literal 'n'	Process Data	No operation

Example: HERE BZ Jump

Before Instruction
PC = address (HERE)

After Instruction
If Zero = 1;
PC = address (Jump)
If Zero = 0;
PC = address (HERE + 2)

CALL Subroutine Call

Syntax: [label] CALL k[,s]

Operands: $0 \leq k \leq 1048575$
 $s \in [0,1]$

Operation: (PC) + 4 → TOS;
k → PC<20:1>
if s = 1
(W) → WS;
(STATUS) → STATUSS;
(BSR) → BSRS

Status Affected: None

Encoding:

1110	110s	k ₇ kkk	kkkk ₀
1111	k ₁₉ kkk	kkkk	kkkk ₈

Description: Subroutine call of entire 2-Mbyte memory range. First, return address (PC + 4) is pushed onto the return stack. If 's' = 1, the W, STATUS and BSR registers are also pushed into their respective shadow registers, WS, STATUSS and BSRS. If 's' = 0, no update occurs (default). Then, the 20-bit value 'k' is loaded into PC<20:1>. CALL is a two-cycle instruction.

Words: 2

Cycles: 2

Q Cycle Activity:

Q1	Q2	Q3	Q4
Decode	Read literal 'k'<7:0>, Push PC to stack	Push PC to stack	Read literal 'k'<19:8>, Write to PC
No operation	No operation	No operation	No operation

Example: HERE CALL THERE, 1

Before Instruction
PC = address (HERE)

After Instruction
PC = address (THERE)
TOS = address (HERE + 4)
WS = W
BSRS = BSR
STATUSS = STATUS

PIC18F6525/6621/8525/8621

CLRF	Clear f								
Syntax:	[<i>label</i>] CLRF f [,a]								
Operands:	0 ≤ f ≤ 255 a ∈ [0,1]								
Operation:	000h → f; 1 → Z								
Status Affected:	Z								
Encoding:	<table border="1"> <tr> <td>0110</td> <td>101a</td> <td>ffff</td> <td>ffff</td> </tr> </table>	0110	101a	ffff	ffff				
0110	101a	ffff	ffff						
Description:	Clears the contents of the specified register. If 'a' is '0', the Access Bank will be selected, overriding the BSR value. If 'a' = 1, then the bank will be selected as per the BSR value (default).								
Words:	1								
Cycles:	1								
Q Cycle Activity:	<table border="1"> <thead> <tr> <th>Q1</th> <th>Q2</th> <th>Q3</th> <th>Q4</th> </tr> </thead> <tbody> <tr> <td>Decode</td> <td>Read register 'f'</td> <td>Process Data</td> <td>Write register 'f'</td> </tr> </tbody> </table>	Q1	Q2	Q3	Q4	Decode	Read register 'f'	Process Data	Write register 'f'
Q1	Q2	Q3	Q4						
Decode	Read register 'f'	Process Data	Write register 'f'						

Example: CLRF FLAG_REG, 1

Before Instruction
FLAG_REG = 0x5A

After Instruction
FLAG_REG = 0x00

CLRWDT	Clear Watchdog Timer								
Syntax:	[<i>label</i>] CLRWDT								
Operands:	None								
Operation:	000h → WDT; 000h → WDT postscaler; 1 → \overline{TO} ; 1 → PD								
Status Affected:	\overline{TO} , PD								
Encoding:	<table border="1"> <tr> <td>0000</td> <td>0000</td> <td>0000</td> <td>0100</td> </tr> </table>	0000	0000	0000	0100				
0000	0000	0000	0100						
Description:	CLRWDT instruction resets the Watchdog Timer. It also resets the postscaler of the WDT. Status bits, \overline{TO} and PD, are set.								
Words:	1								
Cycles:	1								
Q Cycle Activity:	<table border="1"> <thead> <tr> <th>Q1</th> <th>Q2</th> <th>Q3</th> <th>Q4</th> </tr> </thead> <tbody> <tr> <td>Decode</td> <td>No operation</td> <td>Process Data</td> <td>No operation</td> </tr> </tbody> </table>	Q1	Q2	Q3	Q4	Decode	No operation	Process Data	No operation
Q1	Q2	Q3	Q4						
Decode	No operation	Process Data	No operation						

Example: CLRWDT

Before Instruction
WDT Counter = ?

After Instruction
WDT Counter = 0x00
WDT Postscaler = 0
 \overline{TO} = 1
PD = 1

PIC18F6525/6621/8525/8621

COMF Complement f

Syntax: `[label] COMF f[,d[,a]]`

Operands: $0 \leq f \leq 255$
 $d \in [0,1]$
 $a \in [0,1]$

Operation: $(\bar{f}) \rightarrow \text{dest}$

Status Affected: N, Z

Encoding:

0001	11da	ffff	ffff
------	------	------	------

Description: The contents of register 'f' are complemented. If 'd' is '0', the result is stored in W. If 'd' is '1', the result is stored back in register 'f' (default). If 'a' is '0', the Access Bank will be selected, overriding the BSR value. If 'a' = 1, then the bank will be selected as per the BSR value (default).

Words: 1

Cycles: 1

Q Cycle Activity:

Q1	Q2	Q3	Q4
Decode	Read register 'f'	Process Data	Write to destination

Example: `COMF REG, 0, 0`

Before Instruction
REG = 0x13

After Instruction
REG = 0x13
W = 0xEC

CPFSEQ Compare f with W, Skip if f = W

Syntax: `[label] CPFSEQ f[,a]`

Operands: $0 \leq f \leq 255$
 $a \in [0,1]$

Operation: $(f) - (W)$;
skip if $(f) = (W)$
(unsigned comparison)

Status Affected: None

Encoding:

0110	001a	ffff	ffff
------	------	------	------

Description: Compares the contents of data memory location 'f' to the contents of W by performing an unsigned subtraction. If $f = W$, then the fetched instruction is discarded and a NOP is executed instead, making this a two-cycle instruction. If 'a' is '0', the Access Bank will be selected, overriding the BSR value. If 'a' = 1, then the bank will be selected as per the BSR value (default).

Words: 1

Cycles: 1(2)

Note: 3 cycles if skip and followed by a 2-word instruction.

Q Cycle Activity:

Q1	Q2	Q3	Q4
Decode	Read register 'f'	Process Data	No operation

If skip:

Q1	Q2	Q3	Q4
No operation	No operation	No operation	No operation

If skip and followed by 2-word instruction:

Q1	Q2	Q3	Q4
No operation	No operation	No operation	No operation
No operation	No operation	No operation	No operation

Example: `HERE CPFSEQ REG, 0`
`NEQUAL :`
`EQUAL :`

Before Instruction
PC Address = HERE
W = ?
REG = ?

After Instruction
If REG = W;
PC = Address (EQUAL)
If REG \neq W;
PC = Address (NEQUAL)

PIC18F6525/6621/8525/8621

CPFSGT Compare f with W, Skip if f > W

Syntax: `[label] CPFSGT f[,a]`

Operands: $0 \leq f \leq 255$
 $a \in [0,1]$

Operation: $(f) - (W)$;
 skip if $(f) > (W)$
 (unsigned comparison)

Status Affected: None

Encoding:

0110	010a	ffff	ffff
------	------	------	------

Description: Compares the contents of data memory location 'f' to the contents of the W by performing an unsigned subtraction. If the contents of 'f' are greater than the contents of WREG, then the fetched instruction is discarded and a NOP is executed instead, making this a two-cycle instruction. If 'a' is '0', the Access Bank will be selected, overriding the BSR value. If 'a' = 1, then the bank will be selected as per the BSR value (default).

Words: 1

Cycles: 1(2)
Note: 3 cycles if skip and followed by a 2-word instruction.

Q Cycle Activity:

Q1	Q2	Q3	Q4
Decode	Read register 'f'	Process Data	No operation

If skip:

Q1	Q2	Q3	Q4
No operation	No operation	No operation	No operation

If skip and followed by 2-word instruction:

Q1	Q2	Q3	Q4
No operation	No operation	No operation	No operation
No operation	No operation	No operation	No operation

Example:

```

HERE    CPFSGT REG, 0
NGREATER :
GREATER  :
```

Before Instruction

```

PC = Address (HERE)
W  = ?
```

After Instruction

```

If REG > W;
PC = Address (GREATER)
If REG ≤ W;
PC = Address (NGREATER)
```

CPFSLT Compare f with W, Skip if f < W

Syntax: `[label] CPFSLT f[,a]`

Operands: $0 \leq f \leq 255$
 $a \in [0,1]$

Operation: $(f) - (W)$;
 skip if $(f) < (W)$
 (unsigned comparison)

Status Affected: None

Encoding:

0110	000a	ffff	ffff
------	------	------	------

Description: Compares the contents of data memory location 'f' to the contents of W by performing an unsigned subtraction. If the contents of 'f' are less than the contents of W, then the fetched instruction is discarded and a NOP is executed instead, making this a two-cycle instruction. If 'a' is '0', the Access Bank will be selected, overriding the BSR value. If 'a' is '1', the BSR will not be overridden (default).

Words: 1

Cycles: 1(2)
Note: 3 cycles if skip and followed by a 2-word instruction.

Q Cycle Activity:

Q1	Q2	Q3	Q4
Decode	Read register 'f'	Process Data	No operation

If skip:

Q1	Q2	Q3	Q4
No operation	No operation	No operation	No operation

If skip and followed by 2-word instruction:

Q1	Q2	Q3	Q4
No operation	No operation	No operation	No operation
No operation	No operation	No operation	No operation

Example:

```

HERE    CPFSLT REG, 1
NLESS  :
LESS   :
```

Before Instruction

```

PC = Address (HERE)
W  = ?
```

After Instruction

```

If REG < W;
PC = Address (LESS)
If REG ≥ W;
PC = Address (NLESS)
```

PIC18F6525/6621/8525/8621

DAW Decimal Adjust W Register

Syntax: [label] DAW

Operands: None

Operation: If [W<3:0> > 9] or [DC = 1] then
(W<3:0>) + 6 → W<3:0>;
else
(W<3:0>) → W<3:0>

If [W<7:4> > 9] or [C = 1] then
(W<7:4>) + 6 → W<7:4>;
else
(W<7:4>) → W<7:4>

Status Affected: C

Encoding:

0000	0000	0000	0111
------	------	------	------

Description: DAW adjusts the eight-bit value in W resulting from the earlier addition of two variables (each in packed BCD format) and produces a correct packed BCD result.

Words: 1

Cycles: 1

Q Cycle Activity:

Q1	Q2	Q3	Q4
Decode	Read register W	Process Data	Write W

Example 1: DAW

Before Instruction

W = 0xA5
C = 0
DC = 0

After Instruction

W = 0x05
C = 1
DC = 0

Example 2:

Before Instruction

W = 0xCE
C = 0
DC = 0

After Instruction

W = 0x34
C = 1
DC = 0

DECF Decrement f

Syntax: [label] DECF f[d,a]

Operands: $0 \leq f \leq 255$
 $d \in [0,1]$
 $a \in [0,1]$

Operation: (f) - 1 → dest

Status Affected: C, DC, N, OV, Z

Encoding:

0000	01da	ffff	ffff
------	------	------	------

Description: Decrement register 'f'. If 'd' is '0', the result is stored in W. If 'd' is '1', the result is stored back in register 'f' (default). If 'a' is '0', the Access Bank will be selected, overriding the BSR value. If 'a' = 1, then the bank will be selected as per the BSR value (default).

Words: 1

Cycles: 1

Q Cycle Activity:

Q1	Q2	Q3	Q4
Decode	Read register 'f'	Process Data	Write to destination

Example: DECF CNT, 1, 0

Before Instruction

CNT = 0x01
Z = 0

After Instruction

CNT = 0x00
Z = 1

PIC18F6525/6621/8525/8621

DECFSZ Decrement f, Skip if 0

Syntax: [label] DECFSZ f[,d[,a]]

Operands: $0 \leq f \leq 255$
 $d \in [0,1]$
 $a \in [0,1]$

Operation: $(f) - 1 \rightarrow \text{dest}$;
 skip if result = 0

Status Affected: None

Encoding:

0010	11da	ffff	ffff
------	------	------	------

Description: The contents of register 'f' are decremented. If 'd' is '0', the result is placed in W. If 'd' is '1', the result is placed back in register 'f' (default). If the result is '0', the next instruction which is already fetched is discarded and a NOP is executed instead, making it a two-cycle instruction. If 'a' is '0', the Access Bank will be selected, overriding the BSR value. If 'a' = 1, then the bank will be selected as per the BSR value (default).

Words: 1

Cycles: 1(2)
Note: 3 cycles if skip and followed by a 2-word instruction.

Q Cycle Activity:

Q1	Q2	Q3	Q4
Decode	Read register 'f'	Process Data	Write to destination

If skip:

Q1	Q2	Q3	Q4
No operation	No operation	No operation	No operation

If skip and followed by 2-word instruction:

Q1	Q2	Q3	Q4
No operation	No operation	No operation	No operation
No operation	No operation	No operation	No operation

Example: HERE DECFSZ CNT, 1, 1
 GOTO LOOP
 CONTINUE

Before Instruction
 PC = Address (HERE)
 After Instruction
 CNT = CNT - 1
 If CNT = 0;
 PC = Address (CONTINUE)
 If CNT \neq 0;
 PC = Address (HERE + 2)

DCFSNZ Decrement f, Skip if Not 0

Syntax: [label] DCFSNZ f[,d[,a]]

Operands: $0 \leq f \leq 255$
 $d \in [0,1]$
 $a \in [0,1]$

Operation: $(f) - 1 \rightarrow \text{dest}$;
 skip if result \neq 0

Status Affected: None

Encoding:

0100	11da	ffff	ffff
------	------	------	------

Description: The contents of register 'f' are decremented. If 'd' is '0', the result is placed in W. If 'd' is '1', the result is placed back in register 'f' (default). If the result is '0', the next instruction which is already fetched is discarded and a NOP is executed instead, making it a two-cycle instruction. If 'a' is '0', the Access Bank will be selected, overriding the BSR value. If 'a' = 1, then the bank will be selected as per the BSR value (default).

Words: 1

Cycles: 1(2)
Note: 3 cycles if skip and followed by a 2-word instruction.

Q Cycle Activity:

Q1	Q2	Q3	Q4
Decode	Read register 'f'	Process Data	Write to destination

If skip:

Q1	Q2	Q3	Q4
No operation	No operation	No operation	No operation

If skip and followed by 2-word instruction:

Q1	Q2	Q3	Q4
No operation	No operation	No operation	No operation
No operation	No operation	No operation	No operation

Example: HERE DCFSNZ TEMP, 1, 0
 ZERO :
 NZERO :

Before Instruction
 TEMP = ?
 After Instruction
 TEMP = TEMP - 1,
 If TEMP = 0;
 PC = Address (ZERO)
 If TEMP \neq 0;
 PC = Address (NZERO)

PIC18F6525/6621/8525/8621

GOTO Unconditional Branch

Syntax: [label] GOTO k

Operands: $0 \leq k \leq 1048575$

Operation: $k \rightarrow PC<20:1>$

Status Affected: None

Encoding:

1st word (k<7:0>)

2nd word(k<19:8>)

1110	1111	k ₇ kkk	kkkk ₀
1111	k ₁₉ kkk	kkkk	kkkk ₈

Description:

GOTO allows an unconditional branch anywhere within entire 2-Mbyte memory range. The 20-bit value 'k' is loaded into PC<20:1>. GOTO is always a two-cycle instruction.

Words: 2

Cycles: 2

Q Cycle Activity:

Q1	Q2	Q3	Q4
Decode	Read literal 'k'<7:0>,	No operation	Read literal 'k'<19:8>, Write to PC
No operation	No operation	No operation	No operation

Example: GOTO THERE

After Instruction

PC = Address (THERE)

INCF Increment f

Syntax: [label] INCF f[d[,a]]

Operands: $0 \leq f \leq 255$

$d \in [0,1]$

$a \in [0,1]$

Operation: $(f) + 1 \rightarrow \text{dest}$

Status Affected: C, DC, N, OV, Z

Encoding:

0010	10da	ffff	ffff
------	------	------	------

Description:

The contents of register 'f' are incremented. If 'd' is '0', the result is placed in W. If 'd' is '1', the result is placed back in register 'f' (default). If 'a' is '0', the Access Bank will be selected, overriding the BSR value. If 'a' = 1, then the bank will be selected as per the BSR value (default).

Words: 1

Cycles: 1

Q Cycle Activity:

Q1	Q2	Q3	Q4
Decode	Read register 'f'	Process Data	Write to destination

Example: INCF CNT, 1, 0

Before Instruction

CNT = 0xFF

Z = 0

C = ?

DC = ?

After Instruction

CNT = 0x00

Z = 1

C = 1

DC = 1

PIC18F6525/6621/8525/8621

INCFSZ **Increment f, Skip if 0**

Syntax: `[label] INCFSZ f[,d[,a]]`

Operands: $0 \leq f \leq 255$
 $d \in [0,1]$
 $a \in [0,1]$

Operation: $(f) + 1 \rightarrow \text{dest}$;
 skip if result = 0

Status Affected: None

Encoding:

0011	11da	ffff	ffff
------	------	------	------

Description: The contents of register 'f' are incremented. If 'd' is '0', the result is placed in W. If 'd' is '1', the result is placed back in register 'f' (default). If the result is '0', the next instruction which is already fetched is discarded and a NOP is executed instead, making it a two-cycle instruction. If 'a' is '0', the Access Bank will be selected, overriding the BSR value. If 'a' = 1, then the bank will be selected as per the BSR value (default).

Words: 1

Cycles: 1(2)
Note: 3 cycles if skip and followed by a 2-word instruction.

Q Cycle Activity:

Q1	Q2	Q3	Q4
Decode	Read register 'f'	Process Data	Write to destination

If skip:

Q1	Q2	Q3	Q4
No operation	No operation	No operation	No operation

If skip and followed by 2-word instruction:

Q1	Q2	Q3	Q4
No operation	No operation	No operation	No operation
No operation	No operation	No operation	No operation

Example: `HERE INCFSZ CNT, 1, 0`
 `NZERO :`
 `ZERO :`

Before Instruction

PC = Address (HERE)

After Instruction

CNT = CNT + 1
 If CNT = 0;
 PC = Address (ZERO)
 If CNT ≠ 0;
 PC = Address (NZERO)

INFSNZ **Increment f, Skip if Not 0**

Syntax: `[label] INFSNZ f[,d[,a]]`

Operands: $0 \leq f \leq 255$
 $d \in [0,1]$
 $a \in [0,1]$

Operation: $(f) + 1 \rightarrow \text{dest}$;
 skip if result ≠ 0

Status Affected: None

Encoding:

0100	10da	ffff	ffff
------	------	------	------

Description: The contents of register 'f' are incremented. If 'd' is '0', the result is placed in W. If 'd' is '1', the result is placed back in register 'f' (default). If the result is '0', the next instruction which is already fetched is discarded and a NOP is executed instead, making it a two-cycle instruction. If 'a' is '0', the Access Bank will be selected, overriding the BSR value. If 'a' = 1, then the bank will be selected as per the BSR value (default).

Words: 1

Cycles: 1(2)
Note: 3 cycles if skip and followed by a 2-word instruction.

Q Cycle Activity:

Q1	Q2	Q3	Q4
Decode	Read register 'f'	Process Data	Write to destination

If skip:

Q1	Q2	Q3	Q4
No operation	No operation	No operation	No operation

If skip and followed by 2-word instruction:

Q1	Q2	Q3	Q4
No operation	No operation	No operation	No operation
No operation	No operation	No operation	No operation

Example: `HERE INFSNZ REG, 1, 0`
 `ZERO :`
 `NZERO :`

Before Instruction

PC = Address (HERE)

After Instruction

REG = REG + 1
 If REG ≠ 0;
 PC = Address (NZERO)
 If REG = 0;
 PC = Address (ZERO)

PIC18F6525/6621/8525/8621

IORLW Inclusive OR Literal with W

Syntax: [*label*] IORLW *k*

Operands: $0 \leq k \leq 255$

Operation: (W) .OR. *k* → W

Status Affected: N, Z

Encoding:

0000	1001	kkkk	kkkk
------	------	------	------

Description: The contents of W are ORed with the eight-bit literal 'k'. The result is placed in W.

Words: 1

Cycles: 1

Q Cycle Activity:

Q1	Q2	Q3	Q4
Decode	Read literal 'k'	Process Data	Write to W

Example: IORLW 0x35

Before Instruction
W = 0x9A

After Instruction
W = 0xBF

IORWF Inclusive OR W with f

Syntax: [*label*] IORWF *f* [,d [,a]]

Operands: $0 \leq f \leq 255$
 $d \in [0,1]$
 $a \in [0,1]$

Operation: (W) .OR. (*f*) → dest

Status Affected: N, Z

Encoding:

0001	00da	ffff	ffff
------	------	------	------

Description: Inclusive OR W with register 'f'. If 'd' is '0', the result is placed in W. If 'd' is '1', the result is placed back in register 'f' (default). If 'a' is '0', the Access Bank will be selected, overriding the BSR value. If 'a' = 1, then the bank will be selected as per the BSR value (default).

Words: 1

Cycles: 1

Q Cycle Activity:

Q1	Q2	Q3	Q4
Decode	Read register 'f'	Process Data	Write to destination

Example: IORWF RESULT, 0, 1

Before Instruction
RESULT = 0x13
W = 0x91

After Instruction
RESULT = 0x13
W = 0x93

PIC18F6525/6621/8525/8621

LFSR

Load FSR

Syntax: `[label] LFSR f,k`

Operands: $0 \leq f \leq 2$
 $0 \leq k \leq 4095$

Operation: $k \rightarrow \text{FSRf}$

Status Affected: None

Encoding:

1110	1110	00ff	$k_{11}kkk$
1111	0000	k_7kkk	$k_{11}kkk$

Description: The 12-bit literal 'k' is loaded into the file select register pointed to by 'f'.

Words: 2

Cycles: 2

Q Cycle Activity:

	Q1	Q2	Q3	Q4
	Decode	Read literal 'k' MSB	Process Data	Write literal 'k' MSB to FSRfH
	Decode	Read literal 'k' LSB	Process Data	Write literal 'k' to FSRfL

Example: `LFSR 2, 0x3AB`

After Instruction

FSR2H = 0x03
 FSR2L = 0xAB

MOVF

Move f

Syntax: `[label] MOVF f[,d[,a]]`

Operands: $0 \leq f \leq 255$
 $d \in [0,1]$
 $a \in [0,1]$

Operation: $f \rightarrow \text{dest}$

Status Affected: N, Z

Encoding:

0101	00da	ffff	ffff
------	------	------	------

Description: The contents of register 'f' are moved to a destination dependent upon the status of 'd'. If 'd' is '0', the result is placed in W. If 'd' is '1', the result is placed back in register 'f' (default). Location 'f' can be anywhere in the 256-byte bank. If 'a' is '0', the Access Bank will be selected, overriding the BSR value. If 'a' = 1, then the bank will be selected as per the BSR value (default).

Words: 1

Cycles: 1

Q Cycle Activity:

	Q1	Q2	Q3	Q4
	Decode	Read register 'f'	Process Data	Write W

Example: `MOVF REG, 0, 0`

Before Instruction

REG = 0x22
 W = 0xFF

After Instruction

REG = 0x22
 W = 0x22

PIC18F6525/6621/8525/8621

MOVFF Move f to f

Syntax: [label] MOVFF f_s,f_d

Operands: 0 ≤ f_s ≤ 4095
0 ≤ f_d ≤ 4095

Operation: (f_s) → f_d

Status Affected: None

Encoding:

1100	ffff	ffff	ffff _s
1111	ffff	ffff	ffff _d

1st word (source)
2nd word (destin.)

Description: The contents of source register 'f_s' are moved to destination register 'f_d'. Location of source 'f_s' can be anywhere in the 4096-byte data space (000h to FFFh) and location of destination 'f_d' can also be anywhere from 000h to FFFh. Either source or destination can be W (a useful special situation). MOVFF is particularly useful for transferring a data memory location to a peripheral register (such as the transmit buffer or an I/O port). The MOVFF instruction cannot use the PCL, TOSU, TOSH or TOSL as the destination register.

Words: 2

Cycles: 2 (3)

Q Cycle Activity:

Q1	Q2	Q3	Q4
Decode	Read register 'f' (src)	Process Data	No operation
Decode	No operation No dummy read	No operation	Write register 'f' (dest)

Example: MOVFF REG1, REG2

Before Instruction
REG1 = 0x33
REG2 = 0x11

After Instruction
REG1 = 0x33
REG2 = 0x33

MOVLB Move Literal to Low Nibble in BSR

Syntax: [label] MOVLB k

Operands: 0 ≤ k ≤ 255

Operation: k → BSR

Status Affected: None

Encoding:

0000	0001	kkkk	kkkk
------	------	------	------

Description: The 8-bit literal 'k' is loaded into the Bank Select Register (BSR).

Words: 1

Cycles: 1

Q Cycle Activity:

Q1	Q2	Q3	Q4
Decode	Read literal 'k'	Process Data	Write literal 'k' to BSR

Example: MOVLB 5

Before Instruction
BSR register = 0x02

After Instruction
BSR register = 0x05

PIC18F6525/6621/8525/8621

MOVLW Move Literal to W

Syntax: [*label*] MOVLW *k*

Operands: $0 \leq k \leq 255$

Operation: $k \rightarrow W$

Status Affected: None

Encoding:

0000	1110	kkkk	kkkk
------	------	------	------

Description: The eight-bit literal 'k' is loaded into W.

Words: 1

Cycles: 1

Q Cycle Activity:

Q1	Q2	Q3	Q4
Decode	Read literal 'k'	Process Data	Write to W

Example: MOVLW 0x5A

After Instruction
W = 0x5A

MOVWF Move W to f

Syntax: [*label*] MOVWF *f* [,a]

Operands: $0 \leq f \leq 255$
 $a \in [0,1]$

Operation: $(W) \rightarrow f$

Status Affected: None

Encoding:

0110	111a	ffff	ffff
------	------	------	------

Description: Move data from W to register 'f'. Location 'f' can be anywhere in the 256-byte bank. If 'a' is '0', the Access Bank will be selected, overriding the BSR value. If 'a' = 1, then the bank will be selected as per the BSR value (default).

Words: 1

Cycles: 1

Q Cycle Activity:

Q1	Q2	Q3	Q4
Decode	Read register 'f'	Process Data	Write register 'f'

Example: MOVWF REG, 0

Before Instruction

W = 0x4F
REG = 0xFF

After Instruction

W = 0x4F
REG = 0x4F

PIC18F6525/6621/8525/8621

MULLW Multiply Literal with W

Syntax: [*label*] MULLW *k*

Operands: $0 \leq k \leq 255$

Operation: $(W) \times k \rightarrow \text{PRODH:PRODL}$

Status Affected: None

Encoding:

0000	1101	kkkk	kkkk
------	------	------	------

Description: An unsigned multiplication is carried out between the contents of W and the 8-bit literal 'k'. The 16-bit result is placed in PRODH:PRODL register pair. PRODH contains the high byte. W is unchanged.
None of the Status flags are affected. Note that neither overflow nor carry is possible in this operation. A zero result is possible but not detected.

Words: 1

Cycles: 1

Q Cycle Activity:

Q1	Q2	Q3	Q4
Decode	Read literal 'k'	Process Data	Write registers PRODH: PRODL

Example: MULLW 0xC4

Before Instruction

W = 0xE2
PRODH = ?
PRODL = ?

After Instruction

W = 0xE2
PRODH = 0xAD
PRODL = 0x08

MULWF Multiply W with f

Syntax: [*label*] MULWF *f* [,a]

Operands: $0 \leq f \leq 255$
 $a \in [0,1]$

Operation: $(W) \times (f) \rightarrow \text{PRODH:PRODL}$

Status Affected: None

Encoding:

0000	001a	ffff	ffff
------	------	------	------

Description: An unsigned multiplication is carried out between the contents of W and the register file location 'f'. The 16-bit result is stored in the PRODH:PRODL register pair. PRODH contains the high byte.
Both W and 'f' are unchanged. None of the Status flags are affected. Note that neither overflow nor carry is possible in this operation. A zero result is possible but not detected. If 'a' is '0', the Access Bank will be selected, overriding the BSR value. If 'a' = 1, then the bank will be selected as per the BSR value (default).

Words: 1

Cycles: 1

Q Cycle Activity:

Q1	Q2	Q3	Q4
Decode	Read register 'f'	Process Data	Write registers PRODH: PRODL

Example: MULWF REG, 1

Before Instruction

W = 0xC4
REG = 0xB5
PRODH = ?
PRODL = ?

After Instruction

W = 0xC4
REG = 0xB5
PRODH = 0x8A
PRODL = 0x94

PIC18F6525/6621/8525/8621

NEGF	Negate f								
Syntax:	[<i>label</i>] NEGF f [,a]								
Operands:	0 ≤ f ≤ 255 a ∈ [0,1]								
Operation:	(\bar{f}) + 1 → f								
Status Affected:	N, OV, C, DC, Z								
Encoding:	<table border="1"> <tr> <td>0110</td> <td>110a</td> <td>ffff</td> <td>ffff</td> </tr> </table>	0110	110a	ffff	ffff				
0110	110a	ffff	ffff						
Description:	Location 'f' is negated using 2's complement. The result is placed in the data memory location 'f'. If 'a' is '0', the Access Bank will be selected, overriding the BSR value. If 'a' = 1, then the bank will be selected as per the BSR value.								
Words:	1								
Cycles:	1								
Q Cycle Activity:	<table border="1"> <tr> <th>Q1</th> <th>Q2</th> <th>Q3</th> <th>Q4</th> </tr> <tr> <td>Decode</td> <td>Read register 'f'</td> <td>Process Data</td> <td>Write register 'f'</td> </tr> </table>	Q1	Q2	Q3	Q4	Decode	Read register 'f'	Process Data	Write register 'f'
Q1	Q2	Q3	Q4						
Decode	Read register 'f'	Process Data	Write register 'f'						

Example: NEGF REG, 1

Before Instruction

REG = 0011 1010 [0x3A]

After Instruction

REG = 1100 0110 [0xC6]

NOP	No Operation								
Syntax:	[<i>label</i>] NOP								
Operands:	None								
Operation:	No operation								
Status Affected:	None								
Encoding:	<table border="1"> <tr> <td>0000</td> <td>0000</td> <td>0000</td> <td>0000</td> </tr> <tr> <td>1111</td> <td>xxxx</td> <td>xxxx</td> <td>xxxx</td> </tr> </table>	0000	0000	0000	0000	1111	xxxx	xxxx	xxxx
0000	0000	0000	0000						
1111	xxxx	xxxx	xxxx						
Description:	No operation.								
Words:	1								
Cycles:	1								
Q Cycle Activity:	<table border="1"> <tr> <th>Q1</th> <th>Q2</th> <th>Q3</th> <th>Q4</th> </tr> <tr> <td>Decode</td> <td>No operation</td> <td>No operation</td> <td>No operation</td> </tr> </table>	Q1	Q2	Q3	Q4	Decode	No operation	No operation	No operation
Q1	Q2	Q3	Q4						
Decode	No operation	No operation	No operation						

Example:

None.

PIC18F6525/6621/8525/8621

POP Pop Top of Return Stack

Syntax: [*label*] POP
 Operands: None
 Operation: (TOS) → bit bucket
 Status Affected: None
 Encoding:

0000	0000	0000	0110
------	------	------	------

 Description: The TOS value is pulled off the return stack and is discarded. The TOS value then becomes the previous value that was pushed onto the return stack. This instruction is provided to enable the user to properly manage the return stack to incorporate a software stack.
 Words: 1
 Cycles: 1

Q Cycle Activity:

Q1	Q2	Q3	Q4
Decode	No operation	POP TOS value	No operation

Example:

POP		NEW
GOTO		

Before Instruction
 TOS = 0031A2h
 Stack (1 level down)= 014332h

After Instruction
 TOS = 014332h
 PC = NEW

PUSH Push Top of Return Stack

Syntax: [*label*] PUSH
 Operands: None
 Operation: (PC + 2) → TOS
 Status Affected: None
 Encoding:

0000	0000	0000	0101
------	------	------	------

 Description: The PC + 2 is pushed onto the top of the return stack. The previous TOS value is pushed down on the stack. This instruction allows implementing a software stack by modifying TOS and then pushing it onto the return stack.
 Words: 1
 Cycles: 1

Q Cycle Activity:

Q1	Q2	Q3	Q4
Decode	PUSH PC + 2 onto return stack	No operation	No operation

Example:

PUSH		
------	--	--

Before Instruction
 TOS = 00345Ah
 PC = 000124h

After Instruction
 PC = 000126h
 TOS = 000126h
 Stack (1 level down)= 00345Ah

PIC18F6525/6621/8525/8621

RCALL **Relative Call**

Syntax: [*label*] RCALL n

Operands: -1024 ≤ n ≤ 1023

Operation: (PC) + 2 → TOS;
 (PC) + 2 + 2n → PC

Status Affected: None

Encoding:

1101	1nnn	nnnn	nnnn
------	------	------	------

Description: Subroutine call with a jump up to 1K from the current location. First, return address (PC + 2) is pushed onto the stack. Then, add the 2's complement number '2n' to the PC. Since the PC will have incremented to fetch the next instruction, the new address will be PC + 2 + 2n. This instruction is a two-cycle instruction.

Words: 1

Cycles: 2

Q Cycle Activity:

Q1	Q2	Q3	Q4
Decode	Read literal 'n' Push PC to stack	Process Data	Write to PC
No operation	No operation	No operation	No operation

Example: HERE RCALL Jump

Before Instruction

PC = Address (HERE)

After Instruction

PC = Address (Jump)

TOS = Address (HERE + 2)

RESET **Reset**

Syntax: [*label*] RESET

Operands: None

Operation: Reset all registers and flags that are affected by a $\overline{\text{MCLR}}$ Reset.

Status Affected: All

Encoding:

0000	0000	1111	1111
------	------	------	------

Description: This instruction provides a way to execute a $\overline{\text{MCLR}}$ Reset in software.

Words: 1

Cycles: 1

Q Cycle Activity:

Q1	Q2	Q3	Q4
Decode	Start Reset	No operation	No operation

Example: RESET

After Instruction

Registers = Reset Value

Flags* = Reset Value

PIC18F6525/6621/8525/8621

RETFIE **Return from Interrupt**

Syntax: [*label*] RETFIE [*s*]

Operands: $s \in [0,1]$

Operation: (TOS) → PC;
 1 → GIE/GIEH or PEIE/GIEL
 if $s = 1$
 (WS) → W;
 (STATUS) → STATUS;
 (BSRS) → BSR;
 PCLATU, PCLATH are unchanged

Status Affected: GIE/GIEH, PEIE/GIEL.

Encoding:

0000	0000	0001	000s
------	------	------	------

Description: Return from interrupt. Stack is popped and Top-of-Stack (TOS) is loaded into the PC. Interrupts are enabled by setting either the high or low priority global interrupt enable bit. If 's' = 1, the contents of the shadow registers WS, STATUS and BSRS are loaded into their corresponding registers, W, STATUS and BSR. If 's' = 0, no update of these registers occurs (default).

Words: 1

Cycles: 2

Q Cycle Activity:

Q1	Q2	Q3	Q4
Decode	No operation	No operation	Pop PC from stack Set GIEH or GIEL
No operation	No operation	No operation	No operation

Example: RETFIE 1

After Interrupt

PC	=	TOS
W	=	WS
BSR	=	BSRS
STATUS	=	STATUS
GIE/GIEH, PEIE/GIEL	=	1

RETLW **Return Literal to W**

Syntax: [*label*] RETLW *k*

Operands: $0 \leq k \leq 255$

Operation: $k \rightarrow W$;
 (TOS) → PC;
 PCLATU, PCLATH are unchanged

Status Affected: None

Encoding:

0000	1100	kkkk	kkkk
------	------	------	------

Description: W is loaded with the eight-bit literal 'k'. The program counter is loaded from the top of the stack (the return address). The high address latch (PCLATH) remains unchanged.

Words: 1

Cycles: 2

Q Cycle Activity:

Q1	Q2	Q3	Q4
Decode	Read literal 'k'	Process Data	Pop PC from stack, Write to W
No operation	No operation	No operation	No operation

Example:

```
CALL TABLE ; W contains table
              ; offset value
              ; W now has
              ; table value
:
TABLE
  ADDWF PCL ; W = offset
  RETLW k0  ; Begin table
  RETLW k1  ;
:
:
  RETLW kn  ; End of table
Before Instruction
  W        = 0x07
After Instruction
  W        = value of kn
```

PIC18F6525/6621/8525/8621

RETURN Return from Subroutine

Syntax: [*label*] RETURN [*s*]

Operands: $s \in [0,1]$

Operation: (TOS) → PC;
if $s = 1$
(WS) → W;
(STATUS) → STATUS;
(BSRS) → BSR;
PCLATU, PCLATH are unchanged

Status Affected: None

Encoding:

0000	0000	0001	001s
------	------	------	------

Description: Return from subroutine. The stack is popped and the top of the stack (TOS) is loaded into the program counter. If 's' = 1, the contents of the shadow registers WS, STATUS and BSRS are loaded into their corresponding registers, W, STATUS and BSR. If 's' = 0, no update of these registers occurs (default).

Words: 1

Cycles: 2

Q Cycle Activity:

	Q1	Q2	Q3	Q4
Decode	Decode	No operation	Process Data	Pop PC from stack
No operation	No operation	No operation	No operation	No operation

Example: RETURN

After Interrupt
PC = TOS

RLCF Rotate Left f through Carry

Syntax: [*label*] RLCF f [*d* [, *a*]]

Operands: $0 \leq f \leq 255$
 $d \in [0,1]$
 $a \in [0,1]$

Operation: (f<n>) → dest<n + 1>;
(f<7>) → C;
(C) → dest<0>

Status Affected: C, N, Z

Encoding:

0011	01da	ffff	ffff
------	------	------	------

Description: The contents of register 'f' are rotated one bit to the left through the Carry flag. If 'd' is '0', the result is placed in W. If 'd' is '1', the result is stored back in register 'f' (default). If 'a' is '0', the Access Bank will be selected, overriding the BSR value. If 'a' = 1, then the bank will be selected as per the BSR value (default).

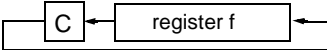

Words: 1

Cycles: 1

Q Cycle Activity:

	Q1	Q2	Q3	Q4
Decode	Decode	Read register 'f'	Process Data	Write to destination

Example: RLCF REG, 0, 0

Before Instruction

REG = 1110 0110
C = 0

After Instruction

REG = 1110 0110
W = 1100 1100
C = 1

PIC18F6525/6621/8525/8621

RLNCF Rotate Left f (No Carry)

Syntax: `[label] RLNCF f[,d[,a]]`

Operands: $0 \leq f \leq 255$
 $d \in [0,1]$
 $a \in [0,1]$

Operation: $(f\langle n \rangle) \rightarrow \text{dest}\langle n + 1 \rangle;$
 $(f\langle 7 \rangle) \rightarrow \text{dest}\langle 0 \rangle$

Status Affected: N, Z

Encoding:

0100	01da	ffff	ffff
------	------	------	------

Description: The contents of register 'f' are rotated one bit to the left. If 'd' is '0', the result is placed in W. If 'd' is '1', the result is stored back in register 'f' (default). If 'a' is '0', the Access Bank will be selected, overriding the BSR value. If 'a' is '1', then the bank will be selected as per the BSR value (default).

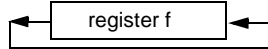

Words: 1
 Cycles: 1

Q Cycle Activity:

Q1	Q2	Q3	Q4
Decode	Read register 'f'	Process Data	Write to destination

Example: `RLNCF REG, 1, 0`

Before Instruction
 REG = 1010 1011
 After Instruction
 REG = 0101 0111

RRCF Rotate Right f through Carry

Syntax: `[label] RRCF f[,d[,a]]`

Operands: $0 \leq f \leq 255$
 $d \in [0,1]$
 $a \in [0,1]$

Operation: $(f\langle n \rangle) \rightarrow \text{dest}\langle n - 1 \rangle;$
 $(f\langle 0 \rangle) \rightarrow C;$
 $(C) \rightarrow \text{dest}\langle 7 \rangle$

Status Affected: C, N, Z

Encoding:

0011	00da	ffff	ffff
------	------	------	------

Description: The contents of register 'f' are rotated one bit to the right through the Carry flag. If 'd' is '0', the result is placed in W. If 'd' is '1', the result is placed back in register 'f' (default). If 'a' is '0', the Access Bank will be selected, overriding the BSR value. If 'a' is '1', then the bank will be selected as per the BSR value (default).

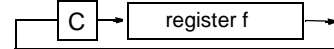

Words: 1
 Cycles: 1

Q Cycle Activity:

Q1	Q2	Q3	Q4
Decode	Read register 'f'	Process Data	Write to destination

Example: `RRCF REG, 0, 0`

Before Instruction
 REG = 1110 0110
 C = 0
 After Instruction
 REG = 1110 0110
 W = 0111 0011
 C = 0

PIC18F6525/6621/8525/8621

RRNCF **Rotate Right f (No Carry)**

Syntax: [*label*] RRNCF f [,d [,a]

Operands: $0 \leq f \leq 255$
 $d \in [0,1]$
 $a \in [0,1]$

Operation: $(f\langle n \rangle) \rightarrow \text{dest}\langle n - 1 \rangle;$
 $(f\langle 0 \rangle) \rightarrow \text{dest}\langle 7 \rangle$

Status Affected: N, Z

Encoding:

0100	00da	ffff	ffff
------	------	------	------

Description: The contents of register 'f' are rotated one bit to the right. If 'd' is '0', the result is placed in W. If 'd' is '1', the result is placed back in register 'f' (default). If 'a' is '0', the Access Bank will be selected, overriding the BSR value. If 'a' is '1', then the bank will be selected as per the BSR value (default).

Words: 1

Cycles: 1

Q Cycle Activity:

Q1	Q2	Q3	Q4
Decode	Read register 'f'	Process Data	Write to destination

Example 1: RRNCF REG, 1, 0

Before Instruction
REG = 1101 0111

After Instruction
REG = 1110 1011

Example 2: RRNCF REG, 0, 0

Before Instruction
W = ?
REG = 1101 0111

After Instruction
W = 1110 1011
REG = 1101 0111

SETF **Set f**

Syntax: [*label*] SETF f [,a]

Operands: $0 \leq f \leq 255$
 $a \in [0,1]$

Operation: $\text{FFh} \rightarrow f$

Status Affected: None

Encoding:

0110	100a	ffff	ffff
------	------	------	------

Description: The contents of the specified register are set to FFh. If 'a' is '0', the Access Bank will be selected, overriding the BSR value. If 'a' is '1', then the bank will be selected as per the BSR value (default).

Words: 1

Cycles: 1

Q Cycle Activity:

Q1	Q2	Q3	Q4
Decode	Read register 'f'	Process Data	Write register 'f'

Example: SETF REG, 1

Before Instruction
REG = 0x5A

After Instruction
REG = 0xFF

PIC18F6525/6621/8525/8621

SLEEP Enter Sleep Mode

Syntax:	[<i>label</i>] SLEEP								
Operands:	None								
Operation:	00h → WDT; 0 → WDT postscaler; 1 → \overline{TO} ; 0 → \overline{PD}								
Status Affected:	\overline{TO} , \overline{PD}								
Encoding:	<table border="1" style="display: inline-table; border-collapse: collapse;"> <tr> <td style="padding: 2px;">0000</td> <td style="padding: 2px;">0000</td> <td style="padding: 2px;">0000</td> <td style="padding: 2px;">0011</td> </tr> </table>	0000	0000	0000	0011				
0000	0000	0000	0011						
Description:	The Power-Down status bit (\overline{PD}) is cleared. The Time-out status bit (\overline{TO}) is set. Watchdog Timer and its postscaler are cleared. The processor is put into Sleep mode with the oscillator stopped.								
Words:	1								
Cycles:	1								
Q Cycle Activity:	<table border="1" style="display: inline-table; border-collapse: collapse; text-align: center;"> <tr> <td style="padding: 2px;">Q1</td> <td style="padding: 2px;">Q2</td> <td style="padding: 2px;">Q3</td> <td style="padding: 2px;">Q4</td> </tr> <tr> <td style="padding: 2px;">Decode</td> <td style="padding: 2px;">No operation</td> <td style="padding: 2px;">Process Data</td> <td style="padding: 2px;">Go to Sleep</td> </tr> </table>	Q1	Q2	Q3	Q4	Decode	No operation	Process Data	Go to Sleep
Q1	Q2	Q3	Q4						
Decode	No operation	Process Data	Go to Sleep						

Example: SLEEP

Before Instruction

\overline{TO} = ?
 \overline{PD} = ?

After Instruction

\overline{TO} = 1 †
 \overline{PD} = 0

† If WDT causes wake-up, this bit is cleared.

SUBFWB Subtract f from W with Borrow

Syntax:	[<i>label</i>] SUBFWB f [,d [,a]								
Operands:	0 ≤ f ≤ 255 d ∈ [0,1] a ∈ [0,1]								
Operation:	(W) – (f) – (\overline{C}) → dest								
Status Affected:	N, OV, C, DC, Z								
Encoding:	<table border="1" style="display: inline-table; border-collapse: collapse;"> <tr> <td style="padding: 2px;">0101</td> <td style="padding: 2px;">01da</td> <td style="padding: 2px;">ffff</td> <td style="padding: 2px;">ffff</td> </tr> </table>	0101	01da	ffff	ffff				
0101	01da	ffff	ffff						
Description:	Subtract register 'f' and Carry flag (borrow) from W (2's complement method). If 'd' is '0', the result is stored in W. If 'd' is '1', the result is stored in register 'f' (default). If 'a' is '0', the Access Bank will be selected, overriding the BSR value. If 'a' is '1', then the bank will be selected as per the BSR value (default).								
Words:	1								
Cycles:	1								
Q Cycle Activity:	<table border="1" style="display: inline-table; border-collapse: collapse; text-align: center;"> <tr> <td style="padding: 2px;">Q1</td> <td style="padding: 2px;">Q2</td> <td style="padding: 2px;">Q3</td> <td style="padding: 2px;">Q4</td> </tr> <tr> <td style="padding: 2px;">Decode</td> <td style="padding: 2px;">Read register 'f'</td> <td style="padding: 2px;">Process Data</td> <td style="padding: 2px;">Write to destination</td> </tr> </table>	Q1	Q2	Q3	Q4	Decode	Read register 'f'	Process Data	Write to destination
Q1	Q2	Q3	Q4						
Decode	Read register 'f'	Process Data	Write to destination						

Example 1: SUBFWB REG, 1, 0

Before Instruction

REG = 3
W = 2
C = 1

After Instruction

REG = FF
W = 2
C = 0
Z = 0
N = 1 ; result is negative

Example 2: SUBFWB REG, 0, 0

Before Instruction

REG = 2
W = 5
C = 1

After Instruction

REG = 2
W = 3
C = 1
Z = 0
N = 0 ; result is positive

Example 3: SUBFWB REG, 1, 0

Before Instruction

REG = 1
W = 2
C = 0

After Instruction

REG = 0
W = 2
C = 1
Z = 1 ; result is zero
N = 0

PIC18F6525/6621/8525/8621

SUBLW Subtract W from Literal

Syntax: [label] SUBLW k

Operands: $0 \leq k \leq 255$

Operation: $k - (W) \rightarrow W$

Status Affected: N, OV, C, DC, Z

Encoding:

0000	1000	kkkk	kkkk
------	------	------	------

Description: W is subtracted from the eight-bit literal 'k'. The result is placed in W.

Words: 1

Cycles: 1

Q Cycle Activity:

Q1	Q2	Q3	Q4
Decode	Read literal 'k'	Process Data	Write to W

Example 1: SUBLW 0x02

Before Instruction

W = 1
C = ?

After Instruction

W = 1
C = 1 ; result is positive
Z = 0
N = 0

Example 2: SUBLW 0x02

Before Instruction

W = 2
C = ?

After Instruction

W = 0
C = 1 ; result is zero
Z = 1
N = 0

Example 3: SUBLW 0x02

Before Instruction

W = 3
C = ?

After Instruction

W = FF ; (2's complement)
C = 0 ; result is negative
Z = 0
N = 1

SUBWF Subtract W from f

Syntax: [label] SUBWF f[,d[,a]]

Operands: $0 \leq f \leq 255$
 $d \in [0,1]$
 $a \in [0,1]$

Operation: $(f) - (W) \rightarrow \text{dest}$

Status Affected: N, OV, C, DC, Z

Encoding:

0101	11da	ffff	ffff
------	------	------	------

Description: Subtract W from register 'f' (2's complement method). If 'd' is '0', the result is stored in W. If 'd' is '1', the result is stored back in register 'f' (default). If 'a' is '0', the Access Bank will be selected, overriding the BSR value. If 'a' is '1', then the bank will be selected as per the BSR value (default).

Words: 1

Cycles: 1

Q Cycle Activity:

Q1	Q2	Q3	Q4
Decode	Read register 'f'	Process Data	Write to destination

Example 1: SUBWF REG, 1, 0

Before Instruction

REG = 3
W = 2
C = ?

After Instruction

REG = 1
W = 2
C = 1 ; result is positive
Z = 0
N = 0

Example 2: SUBWF REG, 0, 0

Before Instruction

REG = 2
W = 2
C = ?

After Instruction

REG = 2
W = 0
C = 1 ; result is zero
Z = 1
N = 0

Example 3: SUBWF REG, 1, 0

Before Instruction

REG = 1
W = 2
C = ?

After Instruction

REG = FFh ; (2's complement)
W = 2
C = 0 ; result is negative
Z = 0
N = 1

PIC18F6525/6621/8525/8621

SUBWFB Subtract W from f with Borrow

Syntax: `[label] SUBWFB f[,d[,a]]`

Operands: $0 \leq f \leq 255$
 $d \in [0,1]$
 $a \in [0,1]$

Operation: $(f) - (W) - (\overline{C}) \rightarrow \text{dest}$

Status Affected: N, OV, C, DC, Z

Encoding:

0101	10da	ffff	ffff
------	------	------	------

Description: Subtract W and the Carry flag (borrow) from register 'f' (2's complement method). If 'd' is '0', the result is stored in W. If 'd' is '1', the result is stored back in register 'f' (default). If 'a' is '0', the Access Bank will be selected, overriding the BSR value. If 'a' is '1', then the bank will be selected as per the BSR value (default).

Words: 1

Cycles: 1

Q Cycle Activity:

Q1	Q2	Q3	Q4
Decode	Read register 'f'	Process Data	Write to destination

Example 1: `SUBWFB REG, 1, 0`

Before Instruction

REG = 0x19 (0001 1001)
W = 0x0D (0000 1101)
C = 1

After Instruction

REG = 0x0C (0000 1011)
W = 0x0D (0000 1101)
C = 1
Z = 0
N = 0 ; result is positive

Example 2: `SUBWFB REG, 0, 0`

Before Instruction

REG = 0x1B (0001 1011)
W = 0x1A (0001 1010)
C = 0

After Instruction

REG = 0x1B (0001 1011)
W = 0x00
C = 1
Z = 1 ; result is zero
N = 0

Example 3: `SUBWFB REG, 1, 0`

Before Instruction

REG = 0x03 (0000 0011)
W = 0x0E (0000 1101)
C = 1

After Instruction

REG = 0xF5 (1111 0100)
; [2's comp]
W = 0x0E (0000 1101)
C = 0
Z = 0
N = 1 ; result is negative

SWAPF Swap f

Syntax: `[label] SWAPF f[,d[,a]]`

Operands: $0 \leq f \leq 255$
 $d \in [0,1]$
 $a \in [0,1]$

Operation: $(f<3:0>) \rightarrow \text{dest}<7:4>;$
 $(f<7:4>) \rightarrow \text{dest}<3:0>$

Status Affected: None

Encoding:

0011	10da	ffff	ffff
------	------	------	------

Description: The upper and lower nibbles of register 'f' are exchanged. If 'd' is '0', the result is placed in W. If 'd' is '1', the result is placed in register 'f' (default). If 'a' is '0', the Access Bank will be selected, overriding the BSR value. If 'a' is '1', then the bank will be selected as per the BSR value (default).

Words: 1

Cycles: 1

Q Cycle Activity:

Q1	Q2	Q3	Q4
Decode	Read register 'f'	Process Data	Write to destination

Example: `SWAPF REG, 1, 0`

Before Instruction

REG = 0x53

After Instruction

REG = 0x35

PIC18F6525/6621/8525/8621

TBLRD Table Read

Syntax: [*label*] TBLRD (*; *+; *-; +*)

Operands: None

Operation: if TBLRD*
(Prog Mem (TBLPTR)) → TABLAT;
TBLPTR – No Change
if TBLRD*+
(Prog Mem (TBLPTR)) → TABLAT;
(TBLPTR) + 1 → TBLPTR
if TBLRD*-
(Prog Mem (TBLPTR)) → TABLAT;
(TBLPTR) – 1 → TBLPTR
if TBLRD*+
(TBLPTR) + 1 → TBLPTR;
(Prog Mem (TBLPTR)) → TABLAT

Status Affected: None

Encoding:

0000	0000	0000	10nn nn=0 * =1 *+ =2 *- =3 +*
------	------	------	---

Description: This instruction is used to read the contents of Program Memory (P.M.). To address the program memory, a pointer called Table Pointer (TBLPTR) is used. The TBLPTR (a 21-bit pointer) points to each byte in the program memory. TBLPTR has a 2-Mbyte address range.
TBLPTR[0] = 0: Least Significant Byte of Program Memory Word
TBLPTR[0] = 1: Most Significant Byte of Program Memory Word
The TBLRD instruction can modify the value of TBLPTR as follows:

- no change
- post-increment
- post-decrement
- pre-increment

Words: 1

Cycles: 2

Q Cycle Activity:

	Q1	Q2	Q3	Q4
Decode	No operation	No operation	No operation	No operation
No operation	No operation (Read Program Memory)	No operation	No operation (Write TABLAT)	

TBLRD Table Read (Continued)

Example 1: TBLRD *+ ;

Before Instruction

TABLAT	=	0x55
TBLPTR	=	0x00A356
MEMORY(0x00A356)	=	0x34

After Instruction

TABLAT	=	0x34
TBLPTR	=	0x00A357

Example 2: TBLRD +* ;

Before Instruction

TABLAT	=	0xAA
TBLPTR	=	0x01A357
MEMORY(0x01A357)	=	0x12
MEMORY(0x01A358)	=	0x34

After Instruction

TABLAT	=	0x34
TBLPTR	=	0x01A358

PIC18F6525/6621/8525/8621

TBLWT Table Write

Syntax: [*label*] TBLWT (*; *+; *-; +*)

Operands: None

Operation: if TBLWT*
(TABLAT) → Holding Register;
TBLPTR – No Change
if TBLWT*+
(TABLAT) → Holding Register;
(TBLPTR) + 1 → TBLPTR
if TBLWT*-
(TABLAT) → Holding Register;
(TBLPTR) – 1 → TBLPTR
if TBLWT*+
(TBLPTR) + 1 → TBLPTR;
(TABLAT) → Holding Register

Status Affected: None

Encoding:	0000	0000	0000	11nn nn=0 * =1 *+ =2 *- =3 +*
-----------	------	------	------	---

Description: This instruction uses the 3 LSBs of TBLPTR to determine which of the 8 holding registers the TABLAT is written to. The holding registers are used to program the contents of Program Memory (P.M.). (Refer to **Section 5.0 “Flash Program Memory”** for additional details on programming Flash memory.)
The TBLPTR (a 21-bit pointer) points to each byte in the program memory. TBLPTR has a 2-MByte address range. The LSB of the TBLPTR selects which byte of the program memory location to access.
TBLPTR[0] = 0: Least Significant Byte of Program Memory Word
TBLPTR[0] = 1: Most Significant Byte of Program Memory Word
The TBLWT instruction can modify the value of TBLPTR as follows:

- no change
- post-increment
- post-decrement
- pre-increment

TBLWT Table Write (Continued)

Words: 1

Cycles: 2

Q Cycle Activity:

	Q1	Q2	Q3	Q4
Decode	No operation	No operation	No operation	No operation
No operation	No operation	No operation (Read TABLAT)	No operation	No operation (Write to Holding Register)

Example 1: TBLWT *+;

Before Instruction
 TABLAT = 0x55
 TBLPTR = 0x00A356
 HOLDING REGISTER (0x00A356) = 0xFF
 After Instructions (table write completion)
 TABLAT = 0x55
 TBLPTR = 0x00A357
 HOLDING REGISTER (0x00A356) = 0x55

Example 2: TBLWT +*;

Before Instruction
 TABLAT = 0x34
 TBLPTR = 0x01389A
 HOLDING REGISTER (0x01389A) = 0xFF
 HOLDING REGISTER (0x01389B) = 0xFF
 After Instruction (table write completion)
 TABLAT = 0x34
 TBLPTR = 0x01389B
 HOLDING REGISTER (0x01389A) = 0xFF
 HOLDING REGISTER (0x01389B) = 0x34

PIC18F6525/6621/8525/8621

TSTFSZ Test f, Skip if 0

Syntax: [label] TSTFSZ f[,a]

Operands: $0 \leq f \leq 255$
 $a \in [0,1]$

Operation: skip if $f = 0$

Status Affected: None

Encoding:

0110	011a	ffff	ffff
------	------	------	------

Description: If 'f' = 0, the next instruction, fetched during the current instruction execution is discarded and a NOP is executed, making this a two-cycle instruction. If 'a' is '0', the Access Bank will be selected, overriding the BSR value. If 'a' is '1', then the bank will be selected as per the BSR value (default).

Words: 1

Cycles: 1(2)

Note: 3 cycles if skip and followed by a 2-word instruction.

Q Cycle Activity:

Q1	Q2	Q3	Q4
Decode	Read register 'f'	Process Data	No operation

If skip:

Q1	Q2	Q3	Q4
No operation	No operation	No operation	No operation

If skip and followed by 2-word instruction:

Q1	Q2	Q3	Q4
No operation	No operation	No operation	No operation
No operation	No operation	No operation	No operation

Example:

```

HERE    TSTFSZ  CNT, 1
NZERO   :
ZERO    :
```

Before Instruction

PC = Address (HERE)

After Instruction

If CNT = 0x00,
PC = Address (ZERO)
If CNT ≠ 0x00,
PC = Address (NZERO)

XORLW Exclusive OR Literal with W

Syntax: [label] XORLW k

Operands: $0 \leq k \leq 255$

Operation: (W) .XOR. k → W

Status Affected: N, Z

Encoding:

0000	1010	kkkk	kkkk
------	------	------	------

Description: The contents of W are XORed with the 8-bit literal 'k'. The result is placed in W.

Words: 1

Cycles: 1

Q Cycle Activity:

Q1	Q2	Q3	Q4
Decode	Read literal 'k'	Process Data	Write to W

Example: XORLW 0xAF

Before Instruction

W = 0xB5

After Instruction

W = 0x1A

PIC18F6525/6621/8525/8621

XORWF Exclusive OR W with f

Syntax: [*label*] XORWF f [,d [,a]]

Operands: $0 \leq f \leq 255$
 $d \in [0,1]$
 $a \in [0,1]$

Operation: (W) .XOR. (f) → dest

Status Affected: N, Z

Encoding:

0001	10da	ffff	ffff
------	------	------	------

Description: Exclusive OR the contents of W with register 'f'. If 'd' is '0', the result is stored in W. If 'd' is '1', the result is stored back in the register 'f' (default). If 'a' is '0', the Access Bank will be selected, overriding the BSR value. If 'a' is '1', then the bank will be selected as per the BSR value (default).

Words: 1

Cycles: 1

Q Cycle Activity:

Q1	Q2	Q3	Q4
Decode	Read register 'f'	Process Data	Write to destination

Example: XORWF REG, 1, 0

Before Instruction

REG = 0xAF
W = 0xB5

After Instruction

REG = 0x1A
W = 0xB5

26.0 DEVELOPMENT SUPPORT

The PICmicro® microcontrollers are supported with a full range of hardware and software development tools:

- Integrated Development Environment
 - MPLAB® IDE Software
- Assemblers/Compilers/Linkers
 - MPASM™ Assembler
 - MPLAB C17 and MPLAB C18 C Compilers
 - MPLINK™ Object Linker/
MPLIB™ Object Librarian
 - MPLAB C30 C Compiler
 - MPLAB ASM30 Assembler/Linker/Library
- Simulators
 - MPLAB SIM Software Simulator
 - MPLAB dsPIC30 Software Simulator
- Emulators
 - MPLAB ICE 2000 In-Circuit Emulator
 - MPLAB ICE 4000 In-Circuit Emulator
- In-Circuit Debugger
 - MPLAB ICD 2
- Device Programmers
 - PRO MATE® II Universal Device Programmer
 - PICSTART® Plus Development Programmer
 - MPLAB PM3 Device Programmer
- Low-Cost Demonstration Boards
 - PICDEM™ 1 Demonstration Board
 - PICDEM.net™ Demonstration Board
 - PICDEM 2 Plus Demonstration Board
 - PICDEM 3 Demonstration Board
 - PICDEM 4 Demonstration Board
 - PICDEM 17 Demonstration Board
 - PICDEM 18R Demonstration Board
 - PICDEM LIN Demonstration Board
 - PICDEM USB Demonstration Board
- Evaluation Kits
 - KEELOQ® Evaluation and Programming Tools
 - PICDEM MSC
 - microID® Developer Kits
 - CAN
 - PowerSmart® Developer Kits
 - Analog

26.1 MPLAB Integrated Development Environment Software

The MPLAB IDE software brings an ease of software development previously unseen in the 8/16-bit microcontroller market. The MPLAB IDE is a Windows® based application that contains:

- An interface to debugging tools
 - simulator
 - programmer (sold separately)
 - emulator (sold separately)
 - in-circuit debugger (sold separately)
- A full-featured editor with color coded context
- A multiple project manager
- Customizable data windows with direct edit of contents
- High-level source code debugging
- Mouse over variable inspection
- Extensive on-line help

The MPLAB IDE allows you to:

- Edit your source files (either assembly or C)
- One touch assemble (or compile) and download to PICmicro emulator and simulator tools (automatically updates all project information)
- Debug using:
 - source files (assembly or C)
 - mixed assembly and C
 - machine code

MPLAB IDE supports multiple debugging tools in a single development paradigm, from the cost effective simulators, through low-cost in-circuit debuggers, to full-featured emulators. This eliminates the learning curve when upgrading to tools with increasing flexibility and power.

26.2 MPASM Assembler

The MPASM assembler is a full-featured, universal macro assembler for all PICmicro MCUs.

The MPASM assembler generates relocatable object files for the MPLINK object linker, Intel® standard HEX files, MAP files to detail memory usage and symbol reference, absolute LST files that contain source lines and generated machine code and COFF files for debugging.

The MPASM assembler features include:

- Integration into MPLAB IDE projects
- User defined macros to streamline assembly code
- Conditional assembly for multi-purpose source files
- Directives that allow complete control over the assembly process

PIC18F6525/6621/8525/8621

26.3 MPLAB C17 and MPLAB C18 C Compilers

The MPLAB C17 and MPLAB C18 Code Development Systems are complete ANSI C compilers for Microchip's PIC17CXXX and PIC18CXXX family of microcontrollers. These compilers provide powerful integration capabilities, superior code optimization and ease of use not found with other compilers.

For easy source level debugging, the compilers provide symbol information that is optimized to the MPLAB IDE debugger.

26.4 MPLINK Object Linker/ MPLIB Object Librarian

The MPLINK object linker combines relocatable objects created by the MPASM assembler and the MPLAB C17 and MPLAB C18 C compilers. It can link relocatable objects from precompiled libraries, using directives from a linker script.

The MPLIB object librarian manages the creation and modification of library files of precompiled code. When a routine from a library is called from a source file, only the modules that contain that routine will be linked in with the application. This allows large libraries to be used efficiently in many different applications.

The object linker/library features include:

- Efficient linking of single libraries instead of many smaller files
- Enhanced code maintainability by grouping related modules together
- Flexible creation of libraries with easy module listing, replacement, deletion and extraction

26.5 MPLAB C30 C Compiler

The MPLAB C30 C compiler is a full-featured, ANSI compliant, optimizing compiler that translates standard ANSI C programs into dsPIC30F assembly language source. The compiler also supports many command line options and language extensions to take full advantage of the dsPIC30F device hardware capabilities and afford fine control of the compiler code generator.

MPLAB C30 is distributed with a complete ANSI C standard library. All library functions have been validated and conform to the ANSI C library standard. The library includes functions for string manipulation, dynamic memory allocation, data conversion, time-keeping and math functions (trigonometric, exponential and hyperbolic). The compiler provides symbolic information for high-level source debugging with the MPLAB IDE.

26.6 MPLAB ASM30 Assembler, Linker and Librarian

MPLAB ASM30 assembler produces relocatable machine code from symbolic assembly language for dsPIC30F devices. MPLAB C30 compiler uses the assembler to produce its object file. The assembler generates relocatable object files that can then be archived or linked with other relocatable object files and archives to create an executable file. Notable features of the assembler include:

- Support for the entire dsPIC30F instruction set
- Support for fixed-point and floating-point data
- Command line interface
- Rich directive set
- Flexible macro language
- MPLAB IDE compatibility

26.7 MPLAB SIM Software Simulator

The MPLAB SIM software simulator allows code development in a PC hosted environment by simulating the PICmicro series microcontrollers on an instruction level. On any given instruction, the data areas can be examined or modified and stimuli can be applied from a file, or user defined key press, to any pin. The execution can be performed in Single-Step, Execute Until Break or Trace mode.

The MPLAB SIM simulator fully supports symbolic debugging using the MPLAB C17 and MPLAB C18 C Compilers, as well as the MPASM assembler. The software simulator offers the flexibility to develop and debug code outside of the laboratory environment, making it an excellent, economical software development tool.

26.8 MPLAB SIM30 Software Simulator

The MPLAB SIM30 software simulator allows code development in a PC hosted environment by simulating the dsPIC30F series microcontrollers on an instruction level. On any given instruction, the data areas can be examined or modified and stimuli can be applied from a file, or user defined key press, to any of the pins.

The MPLAB SIM30 simulator fully supports symbolic debugging using the MPLAB C30 C Compiler and MPLAB ASM30 assembler. The simulator runs in either a Command Line mode for automated tasks, or from MPLAB IDE. This high-speed simulator is designed to debug, analyze and optimize time intensive DSP routines.

26.9 MPLAB ICE 2000 High-Performance Universal In-Circuit Emulator

The MPLAB ICE 2000 universal in-circuit emulator is intended to provide the product development engineer with a complete microcontroller design tool set for PICmicro microcontrollers. Software control of the MPLAB ICE 2000 in-circuit emulator is advanced by the MPLAB Integrated Development Environment, which allows editing, building, downloading and source debugging from a single environment.

The MPLAB ICE 2000 is a full-featured emulator system with enhanced trace, trigger and data monitoring features. Interchangeable processor modules allow the system to be easily reconfigured for emulation of different processors. The universal architecture of the MPLAB ICE in-circuit emulator allows expansion to support new PICmicro microcontrollers.

The MPLAB ICE 2000 in-circuit emulator system has been designed as a real-time emulation system with advanced features that are typically found on more expensive development tools. The PC platform and Microsoft® Windows 32-bit operating system were chosen to best make these features available in a simple, unified application.

26.10 MPLAB ICE 4000 High-Performance Universal In-Circuit Emulator

The MPLAB ICE 4000 universal in-circuit emulator is intended to provide the product development engineer with a complete microcontroller design tool set for high-end PICmicro microcontrollers. Software control of the MPLAB ICE in-circuit emulator is provided by the MPLAB Integrated Development Environment, which allows editing, building, downloading and source debugging from a single environment.

The MPLAB ICE 4000 is a premium emulator system, providing the features of MPLAB ICE 2000, but with increased emulation memory and high-speed performance for dsPIC30F and PIC18XXXX devices. Its advanced emulator features include complex triggering and timing, up to 2 Mb of emulation memory and the ability to view variables in real-time.

The MPLAB ICE 4000 in-circuit emulator system has been designed as a real-time emulation system with advanced features that are typically found on more expensive development tools. The PC platform and Microsoft Windows 32-bit operating system were chosen to best make these features available in a simple, unified application.

26.11 MPLAB ICD 2 In-Circuit Debugger

Microchip's In-Circuit Debugger, MPLAB ICD 2, is a powerful, low-cost, run-time development tool, connecting to the host PC via an RS-232 or high-speed USB interface. This tool is based on the Flash PICmicro MCUs and can be used to develop for these and other PICmicro microcontrollers. The MPLAB ICD 2 utilizes the in-circuit debugging capability built into the Flash devices. This feature, along with Microchip's In-Circuit Serial Programming™ (ICSP™) protocol, offers cost effective in-circuit Flash debugging from the graphical user interface of the MPLAB Integrated Development Environment. This enables a designer to develop and debug source code by setting breakpoints, single-stepping and watching variables, CPU status and peripheral registers. Running at full speed enables testing hardware and applications in real-time. MPLAB ICD 2 also serves as a development programmer for selected PICmicro devices.

26.12 PRO MATE II Universal Device Programmer

The PRO MATE II is a universal, CE compliant device programmer with programmable voltage verification at VDDMIN and VDDMAX for maximum reliability. It features an LCD display for instructions and error messages and a modular detachable socket assembly to support various package types. In Stand-Alone mode, the PRO MATE II device programmer can read, verify and program PICmicro devices without a PC connection. It can also set code protection in this mode.

26.13 MPLAB PM3 Device Programmer

The MPLAB PM3 is a universal, CE compliant device programmer with programmable voltage verification at VDDMIN and VDDMAX for maximum reliability. It features a large LCD display (128 x 64) for menus and error messages and a modular detachable socket assembly to support various package types. The ICSP™ cable assembly is included as a standard item. In Stand-Alone mode, the MPLAB PM3 device programmer can read, verify and program PICmicro devices without a PC connection. It can also set code protection in this mode. MPLAB PM3 connects to the host PC via an RS-232 or USB cable. MPLAB PM3 has high-speed communications and optimized algorithms for quick programming of large memory devices and incorporates an SD/MMC card for file storage and secure data applications.

PIC18F6525/6621/8525/8621

26.14 PICSTART Plus Development Programmer

The PICSTART Plus development programmer is an easy-to-use, low-cost, prototype programmer. It connects to the PC via a COM (RS-232) port. MPLAB Integrated Development Environment software makes using the programmer simple and efficient. The PICSTART Plus development programmer supports most PICmicro devices up to 40 pins. Larger pin count devices, such as the PIC16C92X and PIC17C76X, may be supported with an adapter socket. The PICSTART Plus development programmer is CE compliant.

26.15 PICDEM 1 PICmicro Demonstration Board

The PICDEM 1 demonstration board demonstrates the capabilities of the PIC16C5X (PIC16C54 to PIC16C58A), PIC16C61, PIC16C62X, PIC16C71, PIC16C8X, PIC17C42, PIC17C43 and PIC17C44. All necessary hardware and software is included to run basic demo programs. The sample microcontrollers provided with the PICDEM 1 demonstration board can be programmed with a PRO MATE II device programmer or a PICSTART Plus development programmer. The PICDEM 1 demonstration board can be connected to the MPLAB ICE in-circuit emulator for testing. A prototype area extends the circuitry for additional application components. Features include an RS-232 interface, a potentiometer for simulated analog input, push button switches and eight LEDs.

26.16 PICDEM.net Internet/Ethernet Demonstration Board

The PICDEM.net demonstration board is an Internet/Ethernet demonstration board using the PIC18F452 microcontroller and TCP/IP firmware. The board supports any 40-pin DIP device that conforms to the standard pinout used by the PIC16F877 or PIC18C452. This kit features a user friendly TCP/IP stack, web server with HTML, a 24L256 Serial EEPROM for Xmodem download to web pages into Serial EEPROM, ICSP/MPLAB ICD 2 interface connector, an Ethernet interface, RS-232 interface and a 16 x 2 LCD display. Also included is the book and CD-ROM "TCP/IP Lean, Web Servers for Embedded Systems," by Jeremy Bentham

26.17 PICDEM 2 Plus Demonstration Board

The PICDEM 2 Plus demonstration board supports many 18, 28 and 40-pin microcontrollers, including PIC16F87X and PIC18FXX2 devices. All the necessary hardware and software is included to run the demonstration programs. The sample microcontrollers provided with the PICDEM 2 demonstration board can be programmed with a PRO MATE II device programmer, PICSTART Plus development programmer, or MPLAB ICD 2 with a Universal Programmer Adapter. The MPLAB ICD 2 and MPLAB ICE in-circuit emulators may also be used with the PICDEM 2 demonstration board to test firmware. A prototype area extends the circuitry for additional application components. Some of the features include an RS-232 interface, a 2 x 16 LCD display, a piezo speaker, an on-board temperature sensor, four LEDs and sample PIC18F452 and PIC16F877 Flash microcontrollers.

26.18 PICDEM 3 PIC16C92X Demonstration Board

The PICDEM 3 demonstration board supports the PIC16C923 and PIC16C924 in the PLCC package. All the necessary hardware and software is included to run the demonstration programs.

26.19 PICDEM 4 8/14/18-Pin Demonstration Board

The PICDEM 4 can be used to demonstrate the capabilities of the 8, 14 and 18-pin PIC16XXXX and PIC18XXXX MCUs, including the PIC16F818/819, PIC16F87/88, PIC16F62XA and the PIC18F1320 family of microcontrollers. PICDEM 4 is intended to showcase the many features of these low pin count parts, including LIN and Motor Control using ECCP. Special provisions are made for low-power operation with the supercapacitor circuit and jumpers allow on-board hardware to be disabled to eliminate current draw in this mode. Included on the demo board are provisions for Crystal, RC or Canned Oscillator modes, a five volt regulator for use with a nine volt wall adapter or battery, DB-9 RS-232 interface, ICD connector for programming via ICSP and development with MPLAB ICD 2, 2 x 16 liquid crystal display, PCB footprints for H-Bridge motor driver, LIN transceiver and EEPROM. Also included are: header for expansion, eight LEDs, four potentiometers, three push buttons and a prototyping area. Included with the kit is a PIC16F627A and a PIC18F1320. Tutorial firmware is included along with the User's Guide.

26.20 PICDEM 17 Demonstration Board

The PICDEM 17 demonstration board is an evaluation board that demonstrates the capabilities of several Microchip microcontrollers, including PIC17C752, PIC17C756A, PIC17C762 and PIC17C766. A programmed sample is included. The PRO MATE II device programmer, or the PICSTART Plus development programmer, can be used to reprogram the device for user tailored application development. The PICDEM 17 demonstration board supports program download and execution from external on-board Flash memory. A generous prototype area is available for user hardware expansion.

26.21 PICDEM 18R PIC18C601/801 Demonstration Board

The PICDEM 18R demonstration board serves to assist development of the PIC18C601/801 family of Microchip microcontrollers. It provides hardware implementation of both 8-bit Multiplexed/Demultiplexed and 16-bit Memory modes. The board includes 2 Mb external Flash memory and 128 Kb SRAM memory, as well as serial EEPROM, allowing access to the wide range of memory types supported by the PIC18C601/801.

26.22 PICDEM LIN PIC16C43X Demonstration Board

The powerful LIN hardware and software kit includes a series of boards and three PICmicro microcontrollers. The small footprint PIC16C432 and PIC16C433 are used as slaves in the LIN communication and feature on-board LIN transceivers. A PIC16F874 Flash microcontroller serves as the master. All three microcontrollers are programmed with firmware to provide LIN bus communication.

26.23 PICkit™ 1 Flash Starter Kit

A complete “development system in a box”, the PICkit™ Flash Starter Kit includes a convenient multi-section board for programming, evaluation and development of 8/14-pin Flash PIC® microcontrollers. Powered via USB, the board operates under a simple Windows GUI. The PICkit 1 Starter Kit includes the User’s Guide (on CD ROM), PICkit 1 tutorial software and code for various applications. Also included are MPLAB® IDE (Integrated Development Environment) software, software and hardware “Tips 'n Tricks for 8-pin Flash PIC® Microcontrollers” Handbook and a USB interface cable. Supports all current 8/14-pin Flash PIC microcontrollers, as well as many future planned devices.

26.24 PICDEM USB PIC16C7X5 Demonstration Board

The PICDEM USB Demonstration Board shows off the capabilities of the PIC16C745 and PIC16C765 USB microcontrollers. This board provides the basis for future USB products.

26.25 Evaluation and Programming Tools

In addition to the PICDEM series of circuits, Microchip has a line of evaluation kits and demonstration software for these products.

- KEELOQ evaluation and programming tools for Microchip's HCS Secure Data Products
- CAN developers kit for automotive network applications
- Analog design boards and filter design software
- PowerSmart battery charging evaluation/calibration kits
- IrDA® development kit
- microID development and rLab™ development software
- SEEVAL® designer kit for memory evaluation and endurance calculations
- PICDEM MSC demo boards for Switching mode power supply, high-power IR driver, delta sigma ADC and flow rate sensor

Check the Microchip web page and the latest Product Selector Guide for the complete list of demonstration and evaluation kits.

PIC18F6525/6621/8525/8621

NOTES:

PIC18F6525/6621/8525/8621

27.0 ELECTRICAL CHARACTERISTICS

Absolute Maximum Ratings^(†)

Ambient temperature under bias	-40°C to +125°C
Storage temperature	-65°C to +150°C
Voltage on any pin with respect to VSS (except VDD, $\overline{\text{MCLR}}$ and RA4)	-0.3V to (VDD + 0.3V)
Voltage on VDD with respect to VSS	-0.3V to +5.5V
Voltage on $\overline{\text{MCLR}}$ with respect to VSS (Note 2)	0V to +13.25V
Voltage on RA4 with respect to VSS	0V to +8.5V
Total power dissipation (Note 1)	1.0W
Maximum current out of VSS pin	300 mA
Maximum current into VDD pin	250 mA
Input clamp current, I _{IK} (V _I < 0 or V _I > VDD)	±20 mA
Output clamp current, I _{OK} (V _O < 0 or V _O > VDD)	±20 mA
Maximum output current sunk by any I/O pin	25 mA
Maximum output current sourced by any I/O pin	25 mA
Maximum current sunk by all ports	200 mA
Maximum current sourced by all ports	200 mA

Note 1: Power dissipation is calculated as follows:

$$P_{dis} = V_{DD} \times \{I_{DD} - \sum I_{OH}\} + \sum \{(V_{DD} - V_{OH}) \times I_{OH}\} + \sum (V_{OL} \times I_{OL})$$

- 2:** Voltage spikes below VSS at the $\overline{\text{MCLR}}$ /VPP pin, inducing currents greater than 80 mA, may cause latch-up. Thus, a series resistor of 50-100Ω should be used when applying a “low” level to the $\overline{\text{MCLR}}$ /VPP pin, rather than pulling this pin directly to VSS.

† NOTICE: Stresses above those listed under “Absolute Maximum Ratings” may cause permanent damage to the device. This is a stress rating only and functional operation of the device at those or any other conditions above those indicated in the operation listings of this specification is not implied. Exposure to maximum rating conditions for extended periods may affect device reliability.

PIC18F6525/6621/8525/8621

FIGURE 27-1: PIC18F6X2X/8X2X VOLTAGE-FREQUENCY GRAPH (INDUSTRIAL, EXTENDED)

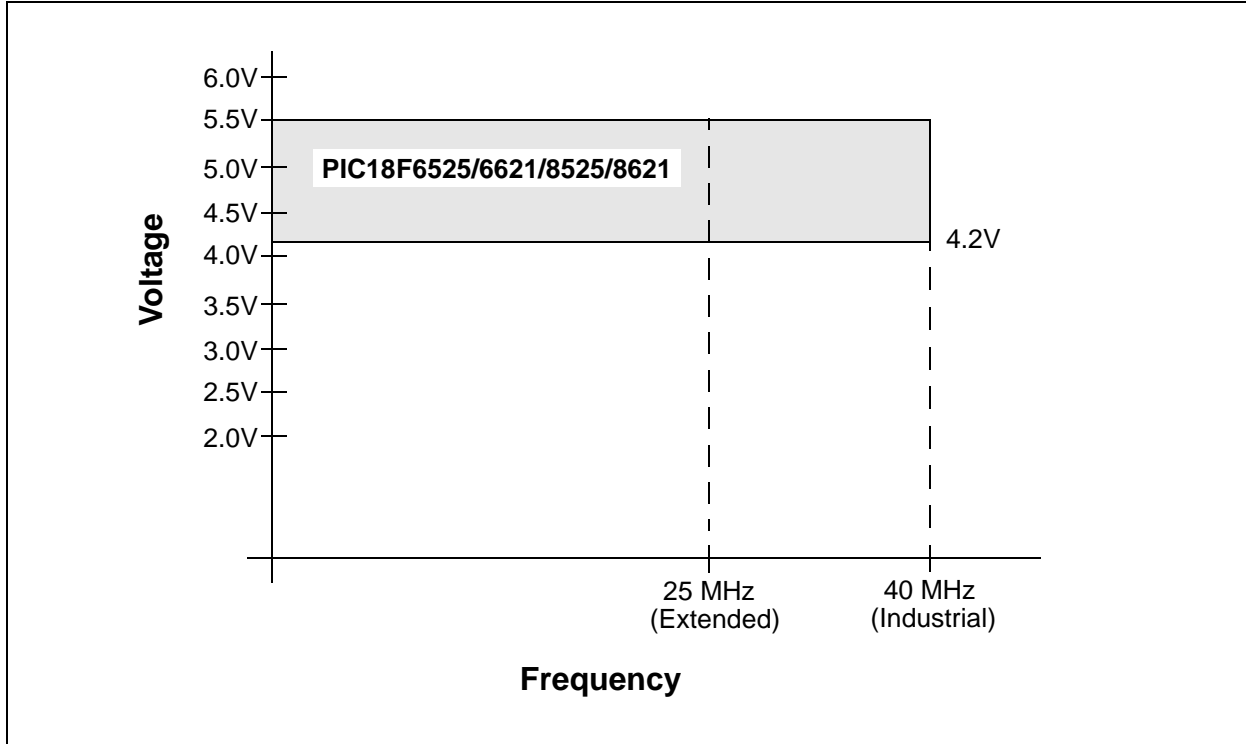
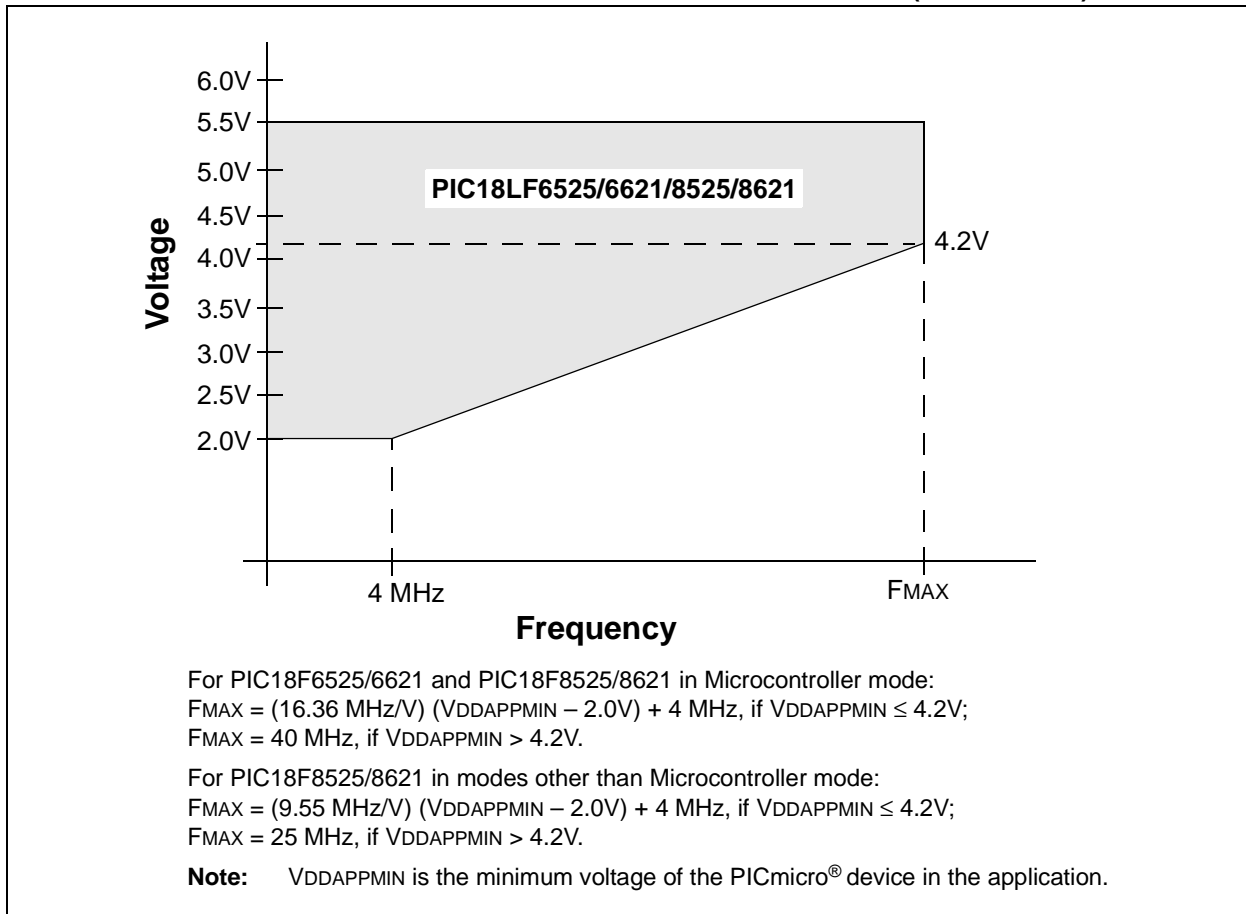

FIGURE 27-2: PIC18LF6X2X/8X2X VOLTAGE-FREQUENCY GRAPH (INDUSTRIAL)



PIC18F6525/6621/8525/8621

27.1 DC Characteristics: Supply Voltage PIC18F6X2X/8X2X (Industrial, Extended) PIC18LF6X2X/8X2X (Industrial)

PIC18LF6X2X/8X2X (Industrial)		Standard Operating Conditions (unless otherwise stated) Operating temperature -40°C ≤ TA ≤ +85°C for industrial					
PIC18F6X2X/8X2X (Industrial, Extended)		Standard Operating Conditions (unless otherwise stated) Operating temperature -40°C ≤ TA ≤ +85°C for industrial -40°C ≤ TA ≤ +125°C for extended					
Param No.	Symbol	Characteristic	Min	Typ	Max	Units	Conditions
D001	VDD	Supply Voltage					
		PIC18LF6X2X/8X2X	2.0	—	5.5	V	
		PIC18F6X2X/8X2X	4.2	—	5.5	V	
D001A	AVDD	Analog Supply Voltage	-0.3	—	+0.3	V	
D002	VDR	RAM Data Retention Voltage⁽¹⁾	1.5	—	—	V	
D003	VPOR	VDD Start Voltage to ensure internal Power-on Reset signal	—	—	0.7	V	See Section 3.1 “Power-on Reset (POR)” for details
D004	SVDD	VDD Rise Rate to ensure internal Power-on Reset signal	0.05	—	—	V/ms	See Section 3.1 “Power-on Reset (POR)” for details
D005	VBOR	Brown-out Reset Voltage					
		BORV1:BORV0 = 11	1.96	—	2.18	V	
		BORV1:BORV0 = 10	2.64	—	2.92	V	
		BORV1:BORV0 = 01	4.11	—	4.55	V	
		BORV1:BORV0 = 00	4.41	—	4.87	V	

Legend: Shading of rows is to assist in readability of the table.

Note 1: This is the limit to which VDD can be lowered in Sleep mode or during a device Reset without losing RAM data.

PIC18F6525/6621/8525/8621

27.2 DC Characteristics: Power-Down and Supply Current PIC18F6X2X/8X2X (Industrial, Extended) PIC18LF6X2X/8X2X (Industrial)

PIC18LF6X2X/8X2X (Industrial)		Standard Operating Conditions (unless otherwise stated) Operating temperature -40°C ≤ TA ≤ +85°C for industrial			
PIC18F6X2X/8X2X (Industrial, Extended)		Standard Operating Conditions (unless otherwise stated) Operating temperature -40°C ≤ TA ≤ +85°C for industrial -40°C ≤ TA ≤ +125°C for extended			
Param No.	Device	Typ	Max	Units	Conditions
	Power-Down Current (IPD)⁽¹⁾				
	PIC18LF6X2X/8X2X	0.2	1	μA	-40°C
		0.2	1	μA	+25°C
		5.0	10	μA	+85°C
	PIC18LF6X2X/8X2X	0.4	1	μA	-40°C
		0.4	1	μA	+25°C
		3.0	18	μA	+85°C
	All devices	0.7	2	μA	-40°C
		0.7	2	μA	+25°C
		15	32	μA	+85°C

Legend: Shading of rows is to assist in readability of the table.

- Note 1:** The power-down current in Sleep mode does not depend on the oscillator type. Power-down current is measured with the part in Sleep mode, with all I/O pins in high-impedance state and tied to VDD or VSS and all features that add delta current disabled (such as WDT, Timer1 Oscillator, BOR, etc.).
- 2:** The supply current is mainly a function of operating voltage, frequency and mode. Other factors, such as I/O pin loading and switching rate, oscillator type and circuit, internal code execution pattern and temperature, also have an impact on the current consumption.
The test conditions for all IDD measurements in active operation mode are:
OSC1 = external square wave, from rail-to-rail; all I/O pins tri-stated, pulled to VDD;
MCLR = VDD; WDT enabled/disabled as specified.
- 3:** For RC oscillator configurations, current through REXT is not included. The current through the resistor can be estimated by the formula $I_r = V_{DD}/2R_{EXT}$ (mA) with REXT in kΩ.
- 4:** The band gap reference is a shared resource used by both BOR and LVD modules. Enabling both modules will consume less than the specified sum current of the modules.

PIC18F6525/6621/8525/8621

27.2 DC Characteristics: Power-Down and Supply Current PIC18F6X2X/8X2X (Industrial, Extended) PIC18LF6X2X/8X2X (Industrial) (Continued)

PIC18LF6X2X/8X2X (Industrial)		Standard Operating Conditions (unless otherwise stated) Operating temperature -40°C ≤ TA ≤ +85°C for industrial					
PIC18F6X2X/8X2X (Industrial, Extended)		Standard Operating Conditions (unless otherwise stated) Operating temperature -40°C ≤ TA ≤ +85°C for industrial -40°C ≤ TA ≤ +125°C for extended					
Param No.	Device	Typ	Max	Units	Conditions		
D010	Supply Current (IDD)^(2,3)						
	PIC18LF6X2X/8X2X	300	500	μA	-40°C	VDD = 2.0V	FOSC = 1 MHz, EC oscillator
		300	500	μA	+25°C		
		850	1000	μA	+85°C		
	PIC18LF6X2X/8X2X	500	900	μA	-40°C	VDD = 3.0V	
		500	900	μA	+25°C		
		1	1.5	mA	+85°C		
	All devices	1	2	mA	-40°C	VDD = 5.0V	
		1	2	mA	+25°C		
		1.3	3	mA	+85°C		
	PIC18LF6X2X/8X2X	1	2	mA	-40°C	VDD = 2.0V	
		1	2	mA	+25°C		
		1.5	2.5	mA	+85°C		
	PIC18LF6X2X/8X2X	1.5	2	mA	-40°C	VDD = 3.0V	
		1.5	2	mA	+25°C		
		2	2.5	mA	+85°C		
	All devices	3	5	mA	-40°C	VDD = 5.0V	
		3	5	mA	+25°C		
		4	6	mA	+85°C		

Legend: Shading of rows is to assist in readability of the table.

- Note 1:** The power-down current in Sleep mode does not depend on the oscillator type. Power-down current is measured with the part in Sleep mode, with all I/O pins in high-impedance state and tied to VDD or VSS and all features that add delta current disabled (such as WDT, Timer1 Oscillator, BOR, etc.).
- 2:** The supply current is mainly a function of operating voltage, frequency and mode. Other factors, such as I/O pin loading and switching rate, oscillator type and circuit, internal code execution pattern and temperature, also have an impact on the current consumption.
The test conditions for all IDD measurements in active operation mode are:
OSC1 = external square wave, from rail-to-rail; all I/O pins tri-stated, pulled to VDD;
MCLR = VDD; WDT enabled/disabled as specified.
- 3:** For RC oscillator configurations, current through REXT is not included. The current through the resistor can be estimated by the formula $I_r = V_{DD}/2R_{EXT}$ (mA) with REXT in kΩ.
- 4:** The band gap reference is a shared resource used by both BOR and LVD modules. Enabling both modules will consume less than the specified sum current of the modules.

PIC18F6525/6621/8525/8621

27.2 DC Characteristics: Power-Down and Supply Current PIC18F6X2X/8X2X (Industrial, Extended) PIC18LF6X2X/8X2X (Industrial) (Continued)

PIC18LF6X2X/8X2X (Industrial)		Standard Operating Conditions (unless otherwise stated) Operating temperature $-40^{\circ}\text{C} \leq T_A \leq +85^{\circ}\text{C}$ for industrial						
PIC18F6X2X/8X2X (Industrial, Extended)		Standard Operating Conditions (unless otherwise stated) Operating temperature $-40^{\circ}\text{C} \leq T_A \leq +85^{\circ}\text{C}$ for industrial $-40^{\circ}\text{C} \leq T_A \leq +125^{\circ}\text{C}$ for extended						
Param No.	Device	Typ	Max	Units	Conditions			
Supply Current (I_{DD})^(2,3)								
	PIC18F6X2X/8X2X	13	27	mA	-40°C	V _{DD} = 4.2V	Fosc = 25 MHz, EC oscillator	
		15	27	mA	$+25^{\circ}\text{C}$			
		19	29	mA	$+85^{\circ}\text{C}$			
	PIC18F6X2X/8X2X	17	31	mA	-40°C			V _{DD} = 5.0V
		21	31	mA	$+25^{\circ}\text{C}$			
		23	34	mA	$+85^{\circ}\text{C}$			
	PIC18F6X2X/8X2X	20	34	mA	-40°C	V _{DD} = 4.2V	Fosc = 40 MHz, EC oscillator	
		24	34	mA	$+25^{\circ}\text{C}$			
		29	44	mA	$+85^{\circ}\text{C}$			
	PIC18F6X2X/8X2X	28	46	mA	-40°C	V _{DD} = 5.0V		
		33	46	mA	$+25^{\circ}\text{C}$			
		40	51	mA	$+85^{\circ}\text{C}$			
D014	PIC18LF6X2X/8X2X	27	45	μA	-10°C	V _{DD} = 2.0V	Fosc = 32 kHz, Timer1 as clock	
		30	50	μA	$+25^{\circ}\text{C}$			
		32	54	μA	$+70^{\circ}\text{C}$			
	PIC18LF6X2X/8X2X	33	55	μA	-10°C	V _{DD} = 3.0V		
		36	60	μA	$+25^{\circ}\text{C}$			
		39	65	μA	$+70^{\circ}\text{C}$			
	All devices	75	125	μA	-10°C	V _{DD} = 5.0V		
		90	150	μA	$+25^{\circ}\text{C}$			
		113	188	μA	$+70^{\circ}\text{C}$			

Legend: Shading of rows is to assist in readability of the table.

- Note 1:** The power-down current in Sleep mode does not depend on the oscillator type. Power-down current is measured with the part in Sleep mode, with all I/O pins in high-impedance state and tied to V_{DD} or V_{SS} and all features that add delta current disabled (such as WDT, Timer1 Oscillator, BOR, etc.).
- 2:** The supply current is mainly a function of operating voltage, frequency and mode. Other factors, such as I/O pin loading and switching rate, oscillator type and circuit, internal code execution pattern and temperature, also have an impact on the current consumption.
The test conditions for all I_{DD} measurements in active operation mode are:
OSC1 = external square wave, from rail-to-rail; all I/O pins tri-stated, pulled to V_{DD};
MCLR = V_{DD}; WDT enabled/disabled as specified.
- 3:** For RC oscillator configurations, current through R_{EXT} is not included. The current through the resistor can be estimated by the formula $I_r = V_{DD}/2R_{EXT}$ (mA) with R_{EXT} in kΩ.
- 4:** The band gap reference is a shared resource used by both BOR and LVD modules. Enabling both modules will consume less than the specified sum current of the modules.

PIC18F6525/6621/8525/8621

27.2 DC Characteristics: Power-Down and Supply Current PIC18F6X2X/8X2X (Industrial, Extended) PIC18LF6X2X/8X2X (Industrial) (Continued)

PIC18LF6X2X/8X2X (Industrial)		Standard Operating Conditions (unless otherwise stated) Operating temperature -40°C ≤ TA ≤ +85°C for industrial					
PIC18F6X2X/8X2X (Industrial, Extended)		Standard Operating Conditions (unless otherwise stated) Operating temperature -40°C ≤ TA ≤ +85°C for industrial -40°C ≤ TA ≤ +125°C for extended					
Param No.	Device	Typ	Max	Units	Conditions		
Module Differential Currents (ΔI_{WDT}, ΔI_{BOR}, ΔI_{LVD}, ΔI_{OSCB}, ΔI_{AD})							
D022 (ΔI_{WDT})	Watchdog Timer	<1	2.0	μA	-40°C	VDD = 2.0V	
		<1	2	μA	+25°C		
		5	20	μA	+85°C		
		VDD = 3.0V	3	10	μA	-40°C	
			3	20	μA	+25°C	
			10	35	μA	+85°C	
			VDD = 5.0V	12	25	μA	-40°C
				15	35	μA	+25°C
20	50	μA	+85°C				
D022A (ΔI_{BOR})	Brown-out Reset ⁽⁴⁾	55	115	μA	-40°C to +85°C	VDD = 3.0V	
		105	175	μA	-40°C to +85°C	VDD = 5.0V	
D022B (ΔI_{LVD})	Low-Voltage Detect ⁽⁴⁾	45	125	μA	-40°C to +85°C	VDD = 2.0V	
		45	150	μA	-40°C to +85°C	VDD = 3.0V	
		45	225	μA	-40°C to +85°C	VDD = 5.0V	
D025 (ΔI_{OSCB})	Timer1 Oscillator	20	27	μA	-10°C	VDD = 2.0V	32 kHz on Timer1
		20	30	μA	+25°C		
		25	35	μA	+70°C		
		VDD = 3.0V	22	60	μA	-10°C	
			22	65	μA	+25°C	
			25	75	μA	+70°C	
		VDD = 5.0V	30	75	μA	-10°C	
			30	85	μA	+25°C	
35	100	μA	+70°C				
D026 (ΔI_{AD})	A/D Converter	<1	2	μA	+25°C	VDD = 2.0V	A/D on, not converting
		<1	2	μA	+25°C	VDD = 3.0V	
		<1	2	μA	+25°C	VDD = 5.0V	

Legend: Shading of rows is to assist in readability of the table.

- Note 1:** The power-down current in Sleep mode does not depend on the oscillator type. Power-down current is measured with the part in Sleep mode, with all I/O pins in high-impedance state and tied to VDD or VSS and all features that add delta current disabled (such as WDT, Timer1 Oscillator, BOR, etc.).
- 2:** The supply current is mainly a function of operating voltage, frequency and mode. Other factors, such as I/O pin loading and switching rate, oscillator type and circuit, internal code execution pattern and temperature, also have an impact on the current consumption.
The test conditions for all IDD measurements in active operation mode are:
 $OSC1$ = external square wave, from rail-to-rail; all I/O pins tri-stated, pulled to VDD;
 $MCLR$ = VDD; WDT enabled/disabled as specified.
- 3:** For RC oscillator configurations, current through REXT is not included. The current through the resistor can be estimated by the formula $I_r = VDD/2R_{EXT}$ (mA) with REXT in k Ω .
- 4:** The band gap reference is a shared resource used by both BOR and LVD modules. Enabling both modules will consume less than the specified sum current of the modules.

PIC18F6525/6621/8525/8621

27.3 DC Characteristics: PIC18F6X2X/8X2X (Industrial, Extended) PIC18LF6X2X/8X2X (Industrial)

DC CHARACTERISTICS			Standard Operating Conditions (unless otherwise stated) Operating temperature $-40^{\circ}\text{C} \leq T_A \leq +85^{\circ}\text{C}$ for industrial $-40^{\circ}\text{C} \leq T_A \leq +125^{\circ}\text{C}$ for extended			
Param No.	Symbol	Characteristic	Min	Max	Units	Conditions
D030 D030A D031 D032 D033 D033A D033B D034	V _{IL}	Input Low Voltage I/O ports: with TTL buffer with Schmitt Trigger buffer RC3 and RC4 <u>MCLR</u> OSC1 OSC1 OSC1 T1OSI	V _{SS} — V _{SS} V _{SS} V _{SS} V _{SS} V _{SS} V _{SS} V _{SS}	0.15 V _{DD} 0.8 0.2 V _{DD} 0.3 V _{DD} 0.2 V _{DD} 0.3 V _{DD} 0.2 V _{DD} 0.3 0.3	V V V V V V V V V	V _{DD} < 4.5V 4.5V ≤ V _{DD} ≤ 5.5V HS, HS+PLL modes RC, EC modes XT, LP modes
D040 D040A D041 D042 D043 D043A D043B D043C D044	V _{IH}	Input High Voltage I/O ports: with TTL buffer with Schmitt Trigger buffer RC3 and RC4 <u>MCLR</u> , OSC1 (EC mode) OSC1 OSC1 OSC1 OSC1 T13CKI	0.25 V _{DD} + 0.8V 2.0 0.8 V _{DD} 0.7 V _{DD} 0.8 V _{DD} 0.7 V _{DD} 0.8 V _{DD} 0.9 V _{DD} 1.6 1.6	V _{DD} V _{DD} V _{DD} V _{DD} V _{DD} V _{DD} V _{DD} V _{DD} V _{DD} V _{DD}	V V V V V V V V V V	V _{DD} < 4.5V 4.5V ≤ V _{DD} ≤ 5.5V HS, HS+PLL modes EC mode RC mode ⁽¹⁾ XT, LP modes
D060 D061 D063	I _{IL}	Input Leakage Current^(2,3) I/O ports <u>MCLR</u> OSC1	— — —	±1 ±5 ±5	μA μA μA	V _{SS} ≤ V _{PIN} ≤ V _{DD} , Pin at high-impedance V _{SS} ≤ V _{PIN} ≤ V _{DD} V _{SS} ≤ V _{PIN} ≤ V _{DD}
D070	I _{PU} I _{PURB}	Weak Pull-up Current PORTB weak pull-up current	50	400	μA	V _{DD} = 5V, V _{PIN} = V _{SS}

Note 1: In RC oscillator configuration, the OSC1/CLKI pin is a Schmitt Trigger input. It is not recommended that the PICmicro[®] device be driven with an external clock while in RC mode.

2: The leakage current on the MCLR pin is strongly dependent on the applied voltage level. The specified levels represent normal operating conditions. Higher leakage current may be measured at different input voltages.

3: Negative current is defined as current sourced by the pin.

4: Parameter is characterized but not tested.

PIC18F6525/6621/8525/8621

27.3 DC Characteristics: PIC18F6X2X/8X2X (Industrial, Extended) PIC18LF6X2X/8X2X (Industrial) (Continued)

DC CHARACTERISTICS			Standard Operating Conditions (unless otherwise stated) Operating temperature $-40^{\circ}\text{C} \leq T_A \leq +85^{\circ}\text{C}$ for industrial $-40^{\circ}\text{C} \leq T_A \leq +125^{\circ}\text{C}$ for extended			
Param No.	Symbol	Characteristic	Min	Max	Units	Conditions
D080	VOL	Output Low Voltage I/O ports	—	0.6	V	$I_{OL} = 8.5 \text{ mA}$, $V_{DD} = 4.5\text{V}$, -40°C to $+85^{\circ}\text{C}$
D080A			—	0.6	V	$I_{OL} = 7.0 \text{ mA}$, $V_{DD} = 4.5\text{V}$, -40°C to $+125^{\circ}\text{C}$
D083		OSC2/CLKO (RC mode)	—	0.6	V	$I_{OL} = 1.6 \text{ mA}$, $V_{DD} = 4.5\text{V}$, -40°C to $+85^{\circ}\text{C}$
D083A			—	0.6	V	$I_{OL} = 1.2 \text{ mA}$, $V_{DD} = 4.5\text{V}$, -40°C to $+125^{\circ}\text{C}$
D090	VOH	Output High Voltage⁽³⁾ I/O ports	$V_{DD} - 0.7$	—	V	$I_{OH} = -3.0 \text{ mA}$, $V_{DD} = 4.5\text{V}$, -40°C to $+85^{\circ}\text{C}$
D090A			$V_{DD} - 0.7$	—	V	$I_{OH} = -2.5 \text{ mA}$, $V_{DD} = 4.5\text{V}$, -40°C to $+125^{\circ}\text{C}$
D092		OSC2/CLKO (RC mode)	$V_{DD} - 0.7$	—	V	$I_{OH} = -1.3 \text{ mA}$, $V_{DD} = 4.5\text{V}$, -40°C to $+85^{\circ}\text{C}$
D092A			$V_{DD} - 0.7$	—	V	$I_{OH} = -1.0 \text{ mA}$, $V_{DD} = 4.5\text{V}$, -40°C to $+125^{\circ}\text{C}$
D150	VOD	Open-Drain High Voltage	—	8.5	V	RA4 pin
Capacitive Loading Specs on Output Pins						
D100 ⁽⁴⁾	Cosc2	OSC2 pin	—	15	pF	In XT, HS and LP modes when external clock is used to drive OSC1
D101	Cio	All I/O pins and OSC2 (in RC mode)	—	50	pF	To meet the AC Timing Specifications
D102	CB	SCL, SDA	—	400	pF	In I ² C™ mode

Note 1: In RC oscillator configuration, the OSC1/CLKI pin is a Schmitt Trigger input. It is not recommended that the PICmicro® device be driven with an external clock while in RC mode.

2: The leakage current on the MCLR pin is strongly dependent on the applied voltage level. The specified levels represent normal operating conditions. Higher leakage current may be measured at different input voltages.

3: Negative current is defined as current sourced by the pin.

4: Parameter is characterized but not tested.

PIC18F6525/6621/8525/8621

TABLE 27-1: COMPARATOR SPECIFICATIONS

Operating Conditions: $3.0V < V_{DD} < 5.5V$, $-40^{\circ}C < T_A < +125^{\circ}C$ (unless otherwise stated)							
Param No.	Sym	Characteristics	Min	Typ	Max	Units	Comments
D300	VIOFF	Input Offset Voltage	—	± 5.0	± 10	mV	
D301	VICM	Input Common Mode Voltage	0	—	$V_{DD} - 1.5$	V	
D302	CMRR	Common Mode Rejection Ratio	55	—	—	dB	
300 300A	TRESP	Response Time ⁽¹⁾	—	150	400 600	ns ns	PIC18F6X2X/8X2X PIC18LF6X2X/8X2X
301	TMC2OV	Comparator Mode Change to Output Valid	—	—	10	μs	

Note 1: Response time measured with one comparator input at $(V_{DD} - 1.5)/2$ while the other input transitions from VSS to VDD.

TABLE 27-2: VOLTAGE REFERENCE SPECIFICATIONS

Operating Conditions: $3.0V < V_{DD} < 5.5V$, $-40^{\circ}C < T_A < +125^{\circ}C$ (unless otherwise stated)							
Spec No.	Sym	Characteristics	Min	Typ	Max	Units	Comments
D310	VRES	Resolution	$V_{DD}/24$	—	$V_{DD}/32$	LSb	
D311	VRAA	Absolute Accuracy	—	—	1/2	LSb	
D312	VRUR	Unit Resistor Value (R)	—	2k	—	Ω	
310	TSET	Settling Time ⁽¹⁾	—	—	10	μs	

Note 1: Settling time measured while $VRR = 1$ and $VR<3:0>$ transitions from 0000 to 1111.

PIC18F6525/6621/8525/8621

FIGURE 27-3: LOW-VOLTAGE DETECT CHARACTERISTICS

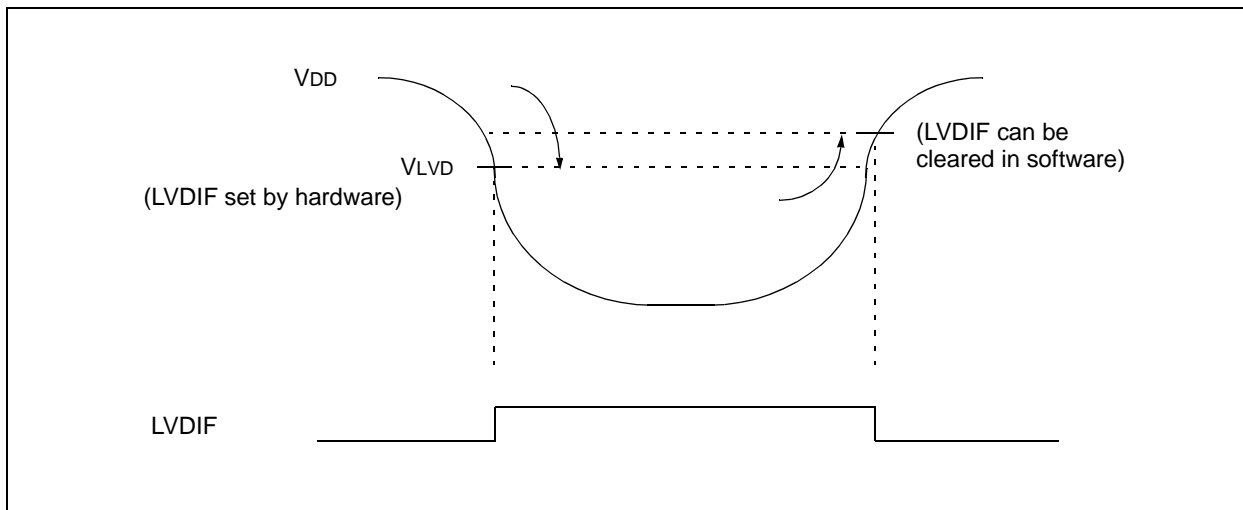

TABLE 27-3: LOW-VOLTAGE DETECT CHARACTERISTICS

LOW-VOLTAGE DETECT CHARACTERISTICS				Standard Operating Conditions (unless otherwise stated) Operating temperature $-40^{\circ}\text{C} \leq T_A \leq +85^{\circ}\text{C}$ for industrial $-40^{\circ}\text{C} \leq T_A \leq +125^{\circ}\text{C}$ for extended				
Param No.	Symbol	Characteristic	Min	Typ†	Max	Units	Conditions	
D420	VLVD	LVD Voltage on VDD transition high-to-low	LVV = 0000	—	—	—	V	
			LVV = 0001	1.96	2.06	2.16	V	
			LVV = 0010	2.16	2.27	2.38	V	
			LVV = 0011	2.35	2.47	2.59	V	
			LVV = 0100	2.46	2.58	2.71	V	
			LVV = 0101	2.64	2.78	2.92	V	
			LVV = 0110	2.75	2.89	3.03	V	
			LVV = 0111	2.95	3.10	3.26	V	
			LVV = 1000	3.24	3.41	3.58	V	
			LVV = 1001	3.43	3.61	3.79	V	
			LVV = 1010	3.53	3.72	3.91	V	
			LVV = 1011	3.72	3.92	4.12	V	
			LVV = 1100	3.92	4.13	4.33	V	
			LVV = 1101	4.11	4.33	4.55	V	
LVV = 1110	4.41	4.64	4.87	V				
D423	V _{BG}	Band Gap Reference Voltage Value	—	1.22	—	V		

† Production tested at $T_{AMB} = 25^{\circ}\text{C}$. Specifications over temp. limits ensured by characterization.

PIC18F6525/6621/8525/8621

TABLE 27-4: MEMORY PROGRAMMING REQUIREMENTS

DC Characteristics			Standard Operating Conditions (unless otherwise stated) Operating temperature $-40^{\circ}\text{C} \leq T_A \leq +85^{\circ}\text{C}$ for industrial $-40^{\circ}\text{C} \leq T_A \leq +125^{\circ}\text{C}$ for extended				
Param No.	Sym	Characteristic	Min	Typ†	Max	Units	Conditions
Internal Program Memory Programming Specifications							
D110	VPP	Voltage on $\overline{\text{MCLR}}/\text{VPP}$ pin	9.00	—	13.25	V	(Note 2)
D112	IPP	Current into $\overline{\text{MCLR}}/\text{VPP}$ pin	—	—	300	μA	
D113	IDDP	Supply Current during Programming	—	—	1.0	mA	
Data EEPROM Memory							
D120	ED	Byte Endurance	100K 10K	1M 100K	— —	E/W E/W	-40°C to $+85^{\circ}\text{C}$ -40°C to $+125^{\circ}\text{C}$
D121	VDRW	VDD for Read/Write	V _{MIN}	—	5.5	V	Using EECON to read/write V _{MIN} = Minimum operating voltage
D122	TDEW	Erase/Write Cycle Time	—	4	—	ms	Provided no other specifications are violated
D123	TRETD	Characteristic Retention	40	—	—	Year	
D124	TREF	Number of Total Erase/Write Cycles before Refresh ⁽¹⁾	1M 100K	10M 1M	— —	E/W E/W	
Program Flash Memory							
D130	EP	Cell Endurance	10K 1K	100K 10K	— —	E/W E/W	-40°C to $+85^{\circ}\text{C}$ -40°C to $+125^{\circ}\text{C}$
D131	VPR	VDD for Read	V _{MIN}	—	5.5	V	V _{MIN} = Minimum operating voltage
D132	VIE	VDD for Block Erase	4.5	—	5.5	V	Using ICSP™ port
D132A	VIW	VDD for Externally Timed Erase or Write	4.5	—	5.5	V	Using ICSP port
D132B	VPEW	VDD for Self-Timed Write and Row Erase	V _{MIN}	—	5.5	V	V _{MIN} = Minimum operating voltage
D133	TIE	ICSP Block Erase Cycle Time	—	4	—	ms	V _{DD} > 4.5V
D133A	TIW	ICSP Erase or Write Cycle Time (externally timed)	1	—	—	ms	V _{DD} > 4.5V
D133A	TIW	Self-Timed Write Cycle Time	—	2	—	ms	
D134	TRETD	Characteristic Retention	40	—	—	Year	Provided no other specifications are violated

† Data in “Typ” column is at 5.0V, 25°C unless otherwise stated. These parameters are for design guidance only and are not tested.

Note 1: Refer to **Section 7.8 “Using the Data EEPROM”** for a more detailed discussion on data EEPROM endurance.

2: Required only if Low-Voltage Programming is disabled.

27.4 AC (Timing) Characteristics

27.4.1 TIMING PARAMETER SYMBOLOGY

The timing parameter symbols have been created following one of the following formats:

1. TppS2ppS
2. TppS
3. TCC:ST (I²C specifications only)
4. Ts (I²C specifications only)

<p>T</p> <p>F Frequency</p>	<p>T Time</p>
----------------------------------	--------------------

Lowercase letters (pp) and their meanings:

<p>pp</p> <p>cc CCP1</p> <p>ck CLKO</p> <p>cs \overline{CS}</p> <p>di SDI</p> <p>do SDO</p> <p>dt Data in</p> <p>io I/O port</p> <p>mc \overline{MCLR}</p>	<p>osc OSC1</p> <p>rd \overline{RD}</p> <p>rw \overline{RD} or \overline{WR}</p> <p>sc SCK</p> <p>ss \overline{SS}</p> <p>t0 T0CKI</p> <p>t1 T1CKI</p> <p>wr \overline{WR}</p>
--	---

Uppercase letters and their meanings:

<p>S</p> <p>F Fall</p> <p>H High</p> <p>I Invalid (High-impedance)</p> <p>L Low</p> <p>I²C only</p> <p>AA output access</p> <p>BUF Bus free</p>	<p>P Period</p> <p>R Rise</p> <p>V Valid</p> <p>Z High-impedance</p> <p>High High</p> <p>Low Low</p>
--	---

TCC:ST (I²C specifications only)

<p>CC</p> <p>HD Hold</p> <p>ST</p> <p>DAT DATA input hold</p> <p>STA Start condition</p>	<p>SU Setup</p> <p>STO Stop condition</p>
---	--

PIC18F6525/6621/8525/8621

27.4.2 TIMING CONDITIONS

The temperature and voltages specified in Table 27-5 apply to all timing specifications, unless otherwise noted. Figure 27-4 specifies the load conditions for the timing specifications.

TABLE 27-5: TEMPERATURE AND VOLTAGE SPECIFICATIONS – AC

AC CHARACTERISTICS	Standard Operating Conditions (unless otherwise stated)
	Operating temperature $-40^{\circ}\text{C} \leq T_A \leq +85^{\circ}\text{C}$ for industrial
	$-40^{\circ}\text{C} \leq T_A \leq +125^{\circ}\text{C}$ for extended
	Operating voltage V_{DD} range as described in DC spec Section 27.1 and Section 27.3 .

LF parts operate for industrial temperatures only.

FIGURE 27-4: LOAD CONDITIONS FOR DEVICE TIMING SPECIFICATIONS

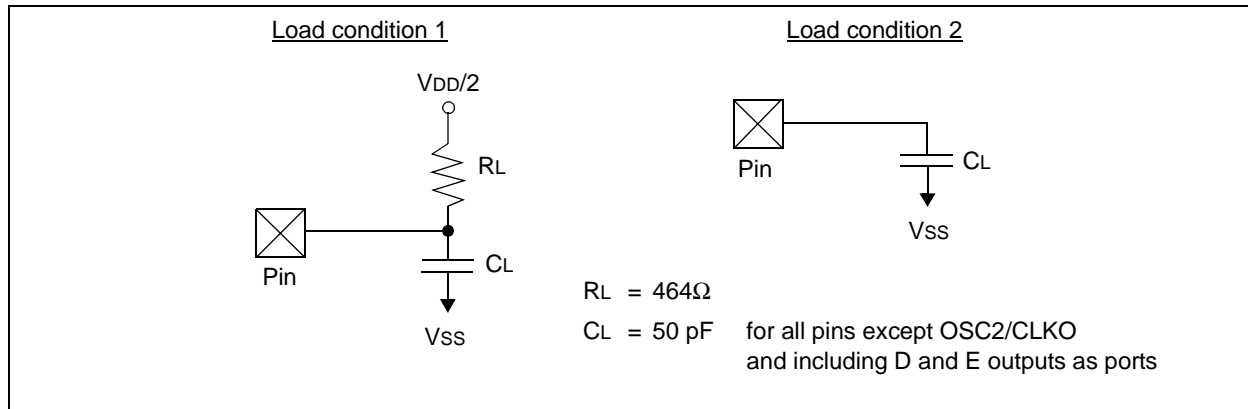

PIC18F6525/6621/8525/8621

27.4.3 TIMING DIAGRAMS AND SPECIFICATIONS

FIGURE 27-5: EXTERNAL CLOCK TIMING (ALL MODES EXCEPT PLL)

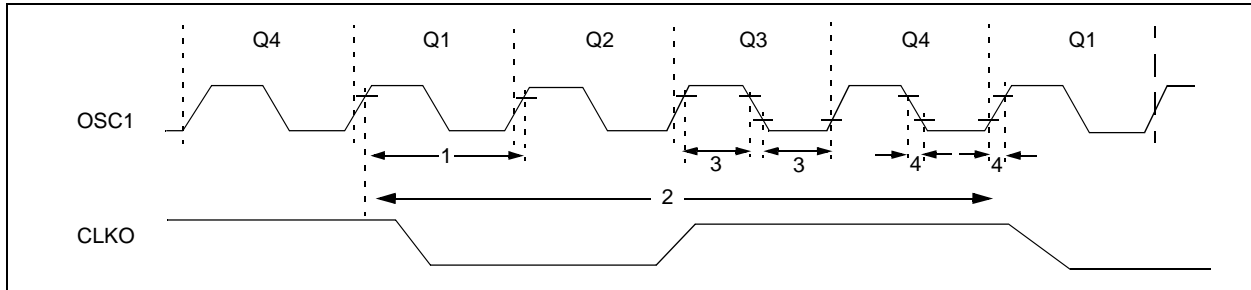

TABLE 27-6: EXTERNAL CLOCK TIMING REQUIREMENTS

Param. No.	Symbol	Characteristic	Min	Max	Units	Conditions
1A	Fosc	External CLKI Frequency ⁽¹⁾	DC	25	MHz	EC, ECIO ⁽²⁾ (-40°C to +85°C)
			DC	40	MHz	EC, ECIO
			DC	25	MHz	EC, ECIO (+85°C to +125°C)
		Oscillator Frequency ⁽¹⁾	DC	4	MHz	RC oscillator
			0.1	4	MHz	XT oscillator
			4	25	MHz	HS oscillator
			4	10	MHz	HS + PLL oscillator
			4	6.25	MHz	HS + PLL oscillator ⁽²⁾
			5	33	kHz	LP Oscillator mode
1	Tosc	External CLKI Period ⁽¹⁾	25	—	ns	EC, ECIO
			40	—	ns	EC, ECIO ⁽²⁾
			40	—	ns	EC, ECIO (+85°C to +125°C)
		Oscillator Period ⁽¹⁾	250	—	ns	RC oscillator
			250	10,000	ns	XT oscillator
			40	250	ns	HS oscillator
			100	250	ns	HS + PLL oscillator
			160	250	ns	HS + PLL oscillator ⁽²⁾
			30	200	μs	LP oscillator
2	Tcy	Instruction Cycle Time ⁽¹⁾	100	—	ns	Tcy = 4/Fosc
3	TosL, TosH	External Clock in (OSC1) High or Low Time	30	—	ns	XT oscillator
			2.5	—	μs	LP oscillator
			10	—	ns	HS oscillator
4	TosR, TosF	External Clock in (OSC1) Rise or Fall Time	—	20	ns	XT oscillator
			—	50	ns	LP oscillator
			—	7.5	ns	HS oscillator

Note 1: Instruction cycle period (Tcy) equals four times the input oscillator time base period for all configurations except PLL. All specified values are based on characterization data for that particular oscillator type under standard operating conditions with the device executing code. Exceeding these specified limits may result in an unstable oscillator operation and/or higher than expected current consumption. All devices are tested to operate at “min.” values with an external clock applied to the OSC1/CLKI pin. When an external clock input is used, the “max.” cycle time limit is “DC” (no clock) for all devices.

2: PIC18F6525/6621/8525/8621 devices using external memory interface.

PIC18F6525/6621/8525/8621

TABLE 27-7: PLL CLOCK TIMING SPECIFICATIONS (V_{DD} = 4.2 TO 5.5V)

Param. No.	Sym	Characteristic	Min	Typ†	Max	Units	Conditions
	F _{OSC}	Oscillator Frequency Range	4	—	10	MHz	HS mode
	F _{SYS}	On-Chip VCO System Frequency	16	—	40	MHz	HS mode
	t _{rc}	PLL Start-up Time (Lock Time)	—	—	2	ms	
	ΔCLK	CLKO Stability (Jitter)	-2	—	+2	%	

† Data in "Typ" column is at 5V, 25°C, unless otherwise stated. These parameters are for design guidance only and are not tested.

FIGURE 27-6: CLKO AND I/O TIMING

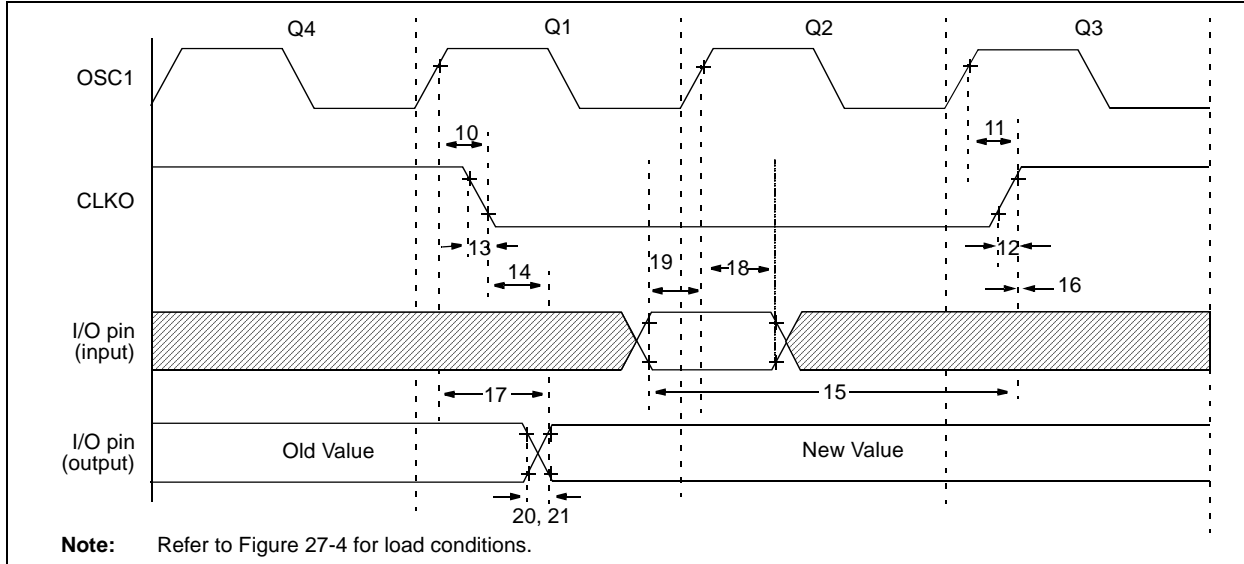

TABLE 27-8: CLKO AND I/O TIMING REQUIREMENTS

Param No.	Symbol	Characteristic	Min	Typ	Max	Units	Conditions	
10	TosH2ckL	OSC1 ↑ to CLKO ↓	—	75	200	ns	(Note 1)	
11	TosH2ckH	OSC1 ↑ to CLKO ↑	—	75	200	ns	(Note 1)	
12	TckR	CLKO Rise Time	—	35	100	ns	(Note 1)	
13	TckF	CLKO Fall Time	—	35	100	ns	(Note 1)	
14	TckL2ioV	CLKO ↓ to Port Out Valid	—	—	0.5 T _{cy} + 20	ns	(Note 1)	
15	TioV2ckH	Port In Valid before CLKO ↑	0.25 T _{cy} + 25	—	—	ns	(Note 1)	
16	TckH2ioL	Port In Hold after CLKO ↑	0	—	—	ns	(Note 1)	
17	TosH2ioV	OSC1 ↑ (Q1 cycle) to Port Out Valid	—	50	150	ns		
18	TosH2ioL	OSC1 ↑ (Q2 cycle) to Port Input Invalid (I/O in hold time)	PIC18F6X2X/8X2X	100	—	—	ns	
18A			PIC18LF6X2X/8X2X	200	—	—	ns	
19	TioV2osH	Port Input Valid to OSC1 ↑ (I/O in setup time)	0	—	—	ns		
20	TioR	Port Output Rise Time	PIC18F6X2X/8X2X	—	10	25	ns	
20A			PIC18LF6X2X/8X2X	—	—	60	ns	
21	TioF	Port Output Fall Time	PIC18F6X2X/8X2X	—	10	25	ns	
21A			PIC18LF6X2X/8X2X	—	—	60	ns	
22†	TINP	INT pin High or Low Time	T _{cy}	—	—	ns		
23†	TRBP	RB7:RB4 Change INT High or Low Time	T _{cy}	—	—	ns		
24†	TRCP	RC7:RC4 Change INT High or Low Time	20	—	—	ns		

† These parameters are asynchronous events not related to any internal clock edges.

Note 1: Measurements are taken in RC mode, where CLKO output is 4 x T_{osc}.

PIC18F6525/6621/8525/8621

FIGURE 27-7: PROGRAM MEMORY READ TIMING DIAGRAM

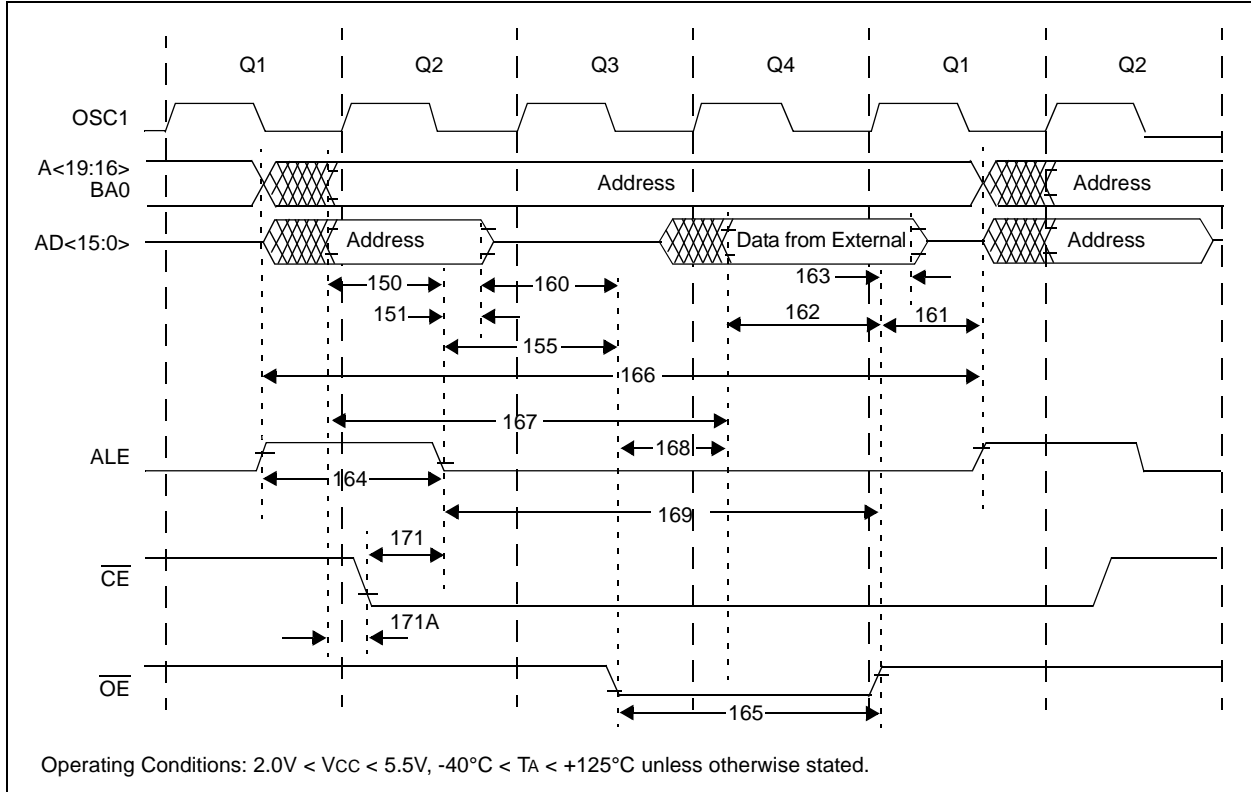

TABLE 27-9: PROGRAM MEMORY READ TIMING REQUIREMENTS

Param. No	Symbol	Characteristics	Min	Typ	Max	Units
150	TadV2alL	Address Out Valid to ALE ↓ (address setup time)	0.25 T _{CY} - 10	—	—	ns
151	TalL2adI	ALE ↓ to Address Out Invalid (address hold time)	5	—	—	ns
155	TalL2oeL	ALE ↓ to OE ↓	10	0.125 T _{CY}	—	ns
160	TadZ2oeL	AD high-Z to OE ↓ (bus release to OE)	0	—	—	ns
161	ToeH2adD	OE ↑ to AD Driven	0.125 T _{CY} - 5	—	—	ns
162	TadV2oeH	LS Data Valid before OE ↑ (data setup time)	20	—	—	ns
163	ToeH2adI	OE ↑ to Data In Invalid (data hold time)	0	—	—	ns
164	TalH2alL	ALE Pulse Width	—	0.25 T _{CY}	—	ns
165	ToeL2oeH	OE Pulse Width	0.5 T _{CY} - 5	0.5 T _{CY}	—	ns
166	TalH2alH	ALE ↑ to ALE ↑ (cycle time)	40 ns	T _{CY}	—	ns
167	Tacc	Address Valid to Data Valid	0.75 T _{CY} - 25	—	—	ns
168	Toe	OE ↓ to Data Valid	—	—	0.5 T _{CY} - 25	ns
169	TalL2oeH	ALE ↓ to OE ↑	0.625 T _{CY} - 10	—	0.625 T _{CY} + 10	ns
171	TalH2csL	Chip Enable Active to ALE ↓	—	—	10	ns
171A	TubL2oeH	AD Valid to Chip Enable Active	0.25 T _{CY} - 20	—	—	ns

PIC18F6525/6621/8525/8621

FIGURE 27-8: PROGRAM MEMORY WRITE TIMING DIAGRAM

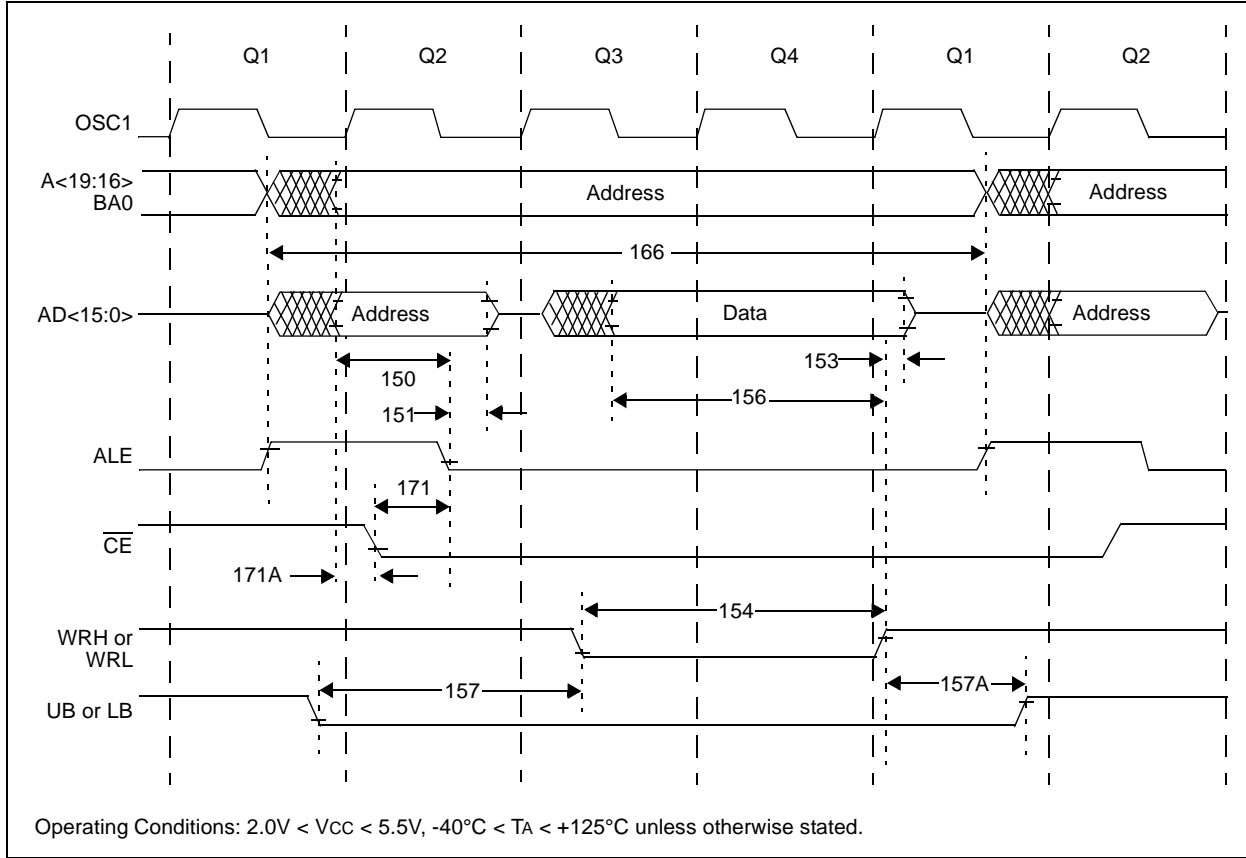

TABLE 27-10: PROGRAM MEMORY WRITE TIMING REQUIREMENTS

Param. No	Symbol	Characteristics	Min	Typ	Max	Units
150	TadV2aL	Address Out Valid to ALE ↓ (address setup time)	0.25 T _{CY} - 10	—	—	ns
151	TaIL2adI	ALE ↓ to Address Out Invalid (address hold time)	5	—	—	ns
153	TwrH2adI	WRn ↑ to Data Out Invalid (data hold time)	5	—	—	ns
154	TwrL	WRn Pulse Width	0.5 T _{CY} - 5	0.5 T _{CY}	—	ns
156	TadV2wrH	Data Valid before WRn ↑ (data setup time)	0.5 T _{CY} - 10	—	—	ns
157	TbsV2wrL	Byte Select Valid before WRn ↓ (byte select setup time)	0.25 T _{CY}	—	—	ns
157A	TwrH2bsI	WRn ↑ to Byte Select Invalid (byte select hold time)	0.125 T _{CY} - 5	—	—	ns
166	TaIH2aIH	ALE ↑ to ALE ↑ (cycle time)	—	T _{CY}	—	ns
171	TaIH2csL	Chip Enable Active to ALE ↓	—	—	10	ns
171A	TubL2oeH	AD Valid to Chip Enable Active	0.25 T _{CY} - 20	—	—	ns

PIC18F6525/6621/8525/8621

FIGURE 27-9: RESET, WATCHDOG TIMER, OSCILLATOR START-UP TIMER AND POWER-UP TIMER TIMING

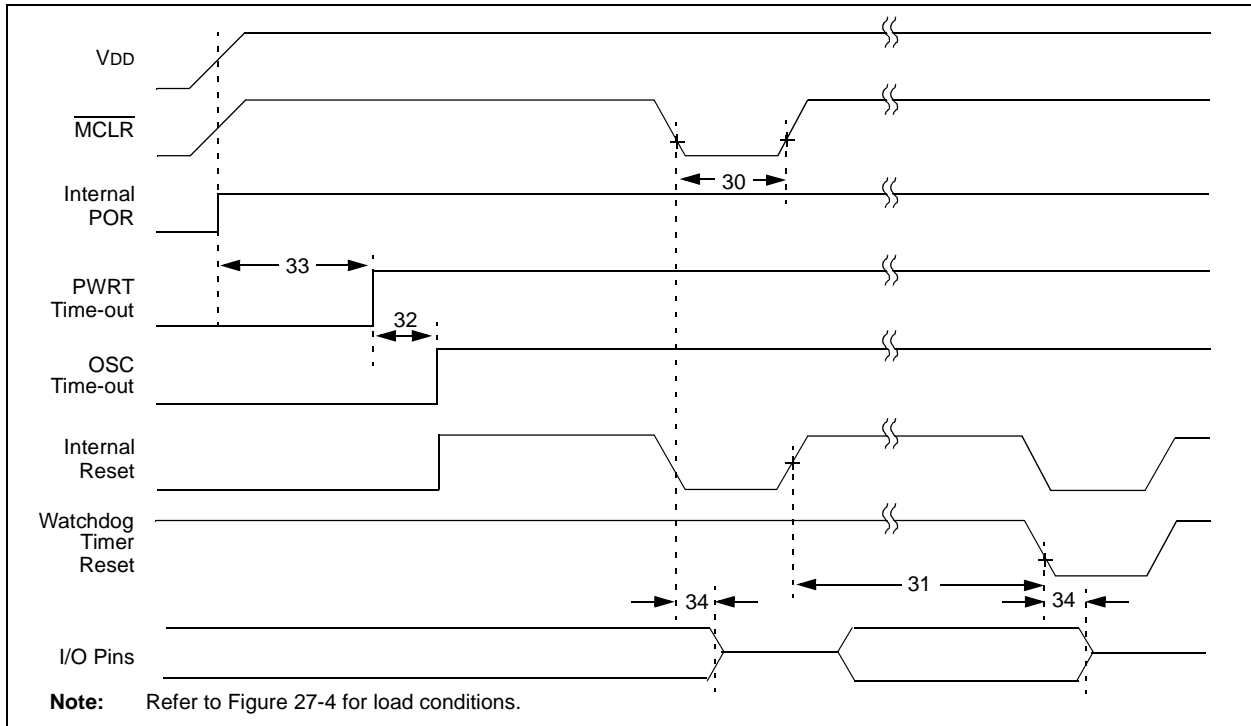

FIGURE 27-10: BROWN-OUT RESET TIMING

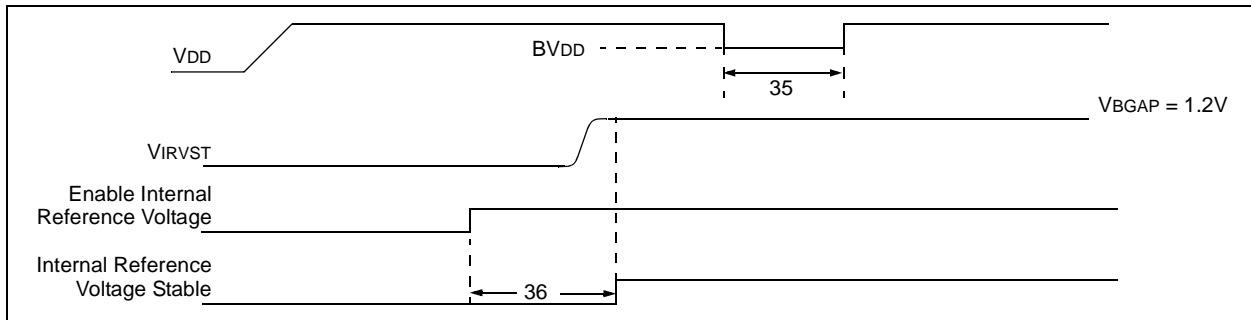

TABLE 27-11: RESET, WATCHDOG TIMER, OSCILLATOR START-UP TIMER, POWER-UP TIMER AND BROWN-OUT RESET REQUIREMENTS

Param. No.	Symbol	Characteristic	Min	Typ	Max	Units	Conditions
30	Tm _{CL}	MCLR Pulse Width (low)	2	—	—	μs	
31	TWDT	Watchdog Timer Time-out Period (no postscaler)	7	18	33	ms	
32	TOST	Oscillation Start-up Timer Period	1024 T _{osc}	—	1024 T _{osc}	—	T _{osc} = OSC1 period
33	TPWRT	Power-up Timer Period	28	72	132	ms	
34	TIOZ	I/O High-impedance from MCLR Low or Watchdog Timer Reset	—	2	—	μs	
35	TBOR	Brown-out Reset Pulse Width	200	—	—	μs	V _{DD} ≤ BV _{DD} (see D005)
36	TIRVST	Time for Internal Reference Voltage to become stable	—	20	50	μs	
37	TLVD	Low-Voltage Detect Pulse Width	200	—	—	μs	V _{DD} ≤ VL _{VD}

PIC18F6525/6621/8525/8621

FIGURE 27-11: TIMER0 AND TIMER1 EXTERNAL CLOCK TIMINGS

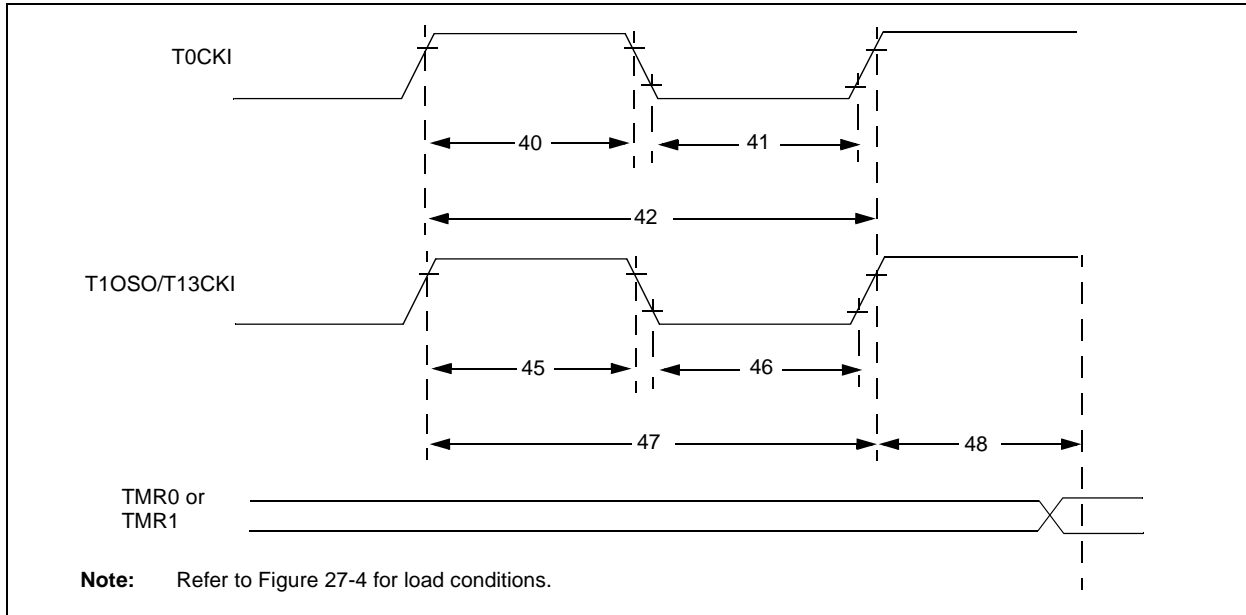

TABLE 27-12: TIMER0 AND TIMER1 EXTERNAL CLOCK REQUIREMENTS

Param. No.	Symbol	Characteristic		Min	Max	Units	Conditions	
40	Tt0H	T0CKI High Pulse Width	No prescaler	$0.5 T_{CY} + 20$	—	ns		
			With prescaler	10	—	ns		
41	Tt0L	T0CKI Low Pulse Width	No prescaler	$0.5 T_{CY} + 20$	—	ns		
			With prescaler	10	—	ns		
42	Tt0P	T0CKI Period	No prescaler	$T_{CY} + 10$	—	ns		
			With prescaler	Greater of: 20 ns or $\frac{T_{CY} + 40}{N}$	—	ns		N = prescale value (1, 2, 4, ..., 256)
45	Tt1H	T13CKI High Time	Synchronous, no prescaler	$0.5 T_{CY} + 20$	—	ns		
			Synchronous, with prescaler	PIC18F6X2X/8X2X	10	—		ns
				PIC18LF6X2X/8X2X	25	—		ns
			Asynchronous	PIC18F6X2X/8X2X	30	—		ns
PIC18LF6X2X/8X2X	50	—		ns				
46	Tt1L	T13CKI Low Time	Synchronous, no prescaler	$0.5 T_{CY} + 5$	—	ns		
			Synchronous, with prescaler	PIC18F6X2X/8X2X	10	—		ns
				PIC18LF6X2X/8X2X	25	—		ns
			Asynchronous	PIC18F6X2X/8X2X	30	—		ns
PIC18LF6X2X/8X2X	TBD	TBD		ns				
47	Tt1P	T13CKI Input Period	Synchronous	Greater of: 20 ns or $\frac{T_{CY} + 40}{N}$	—	ns	N = prescale value (1, 2, 4, 8)	
			Asynchronous	60	—	ns		
	Ft1	T13CKI Oscillator Input Frequency Range		DC	50	kHz		
48	Tcke2tmr1	Delay from External T13CKI Clock Edge to Timer Increment		$2 T_{OSC}$	$7 T_{OSC}$	—		

Legend: TBD = To Be Determined

PIC18F6525/6621/8525/8621

FIGURE 27-12: CAPTURE/COMPARE/PWM TIMINGS (ALL ECCP/CCP MODULES)

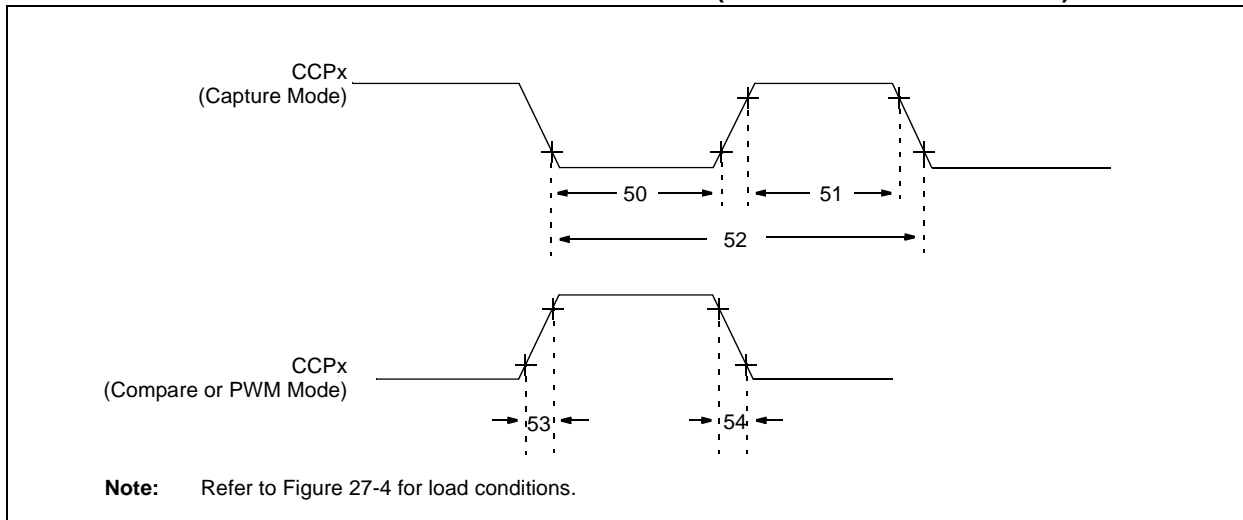

TABLE 27-13: CAPTURE/COMPARE/PWM REQUIREMENTS (ALL ECCP/CCP MODULES)

Param. No.	Symbol	Characteristic		Min	Max	Units	Conditions	
50	TccL	CCPx Input Low Time	No prescaler	$0.5 T_{CY} + 20$	—	ns		
			With prescaler	PIC18F6X2X/8X2X	10	—		ns
				PIC18LF6X2X/8X2X	20	—		ns
51	TccH	CCPx Input High Time	No prescaler	$0.5 T_{CY} + 20$	—	ns		
			With prescaler	PIC18F6X2X/8X2X	10	—		ns
				PIC18LF6X2X/8X2X	20	—		ns
52	TccP	CCPx Input Period		$\frac{3 T_{CY} + 40}{N}$	—	ns	N = prescale value (1,4 or 16)	
53	TccR	CCPx Output Rise Time	PIC18F6X2X/8X2X	—	25	ns		
			PIC18LF6X2X/8X2X	—	45	ns		
54	TccF	CCPx Output Fall Time	PIC18F6X2X/8X2X	—	25	ns		
			PIC18LF6X2X/8X2X	—	45	ns		

PIC18F6525/6621/8525/8621

FIGURE 27-13: PARALLEL SLAVE PORT TIMING (PIC18F8525/8621)

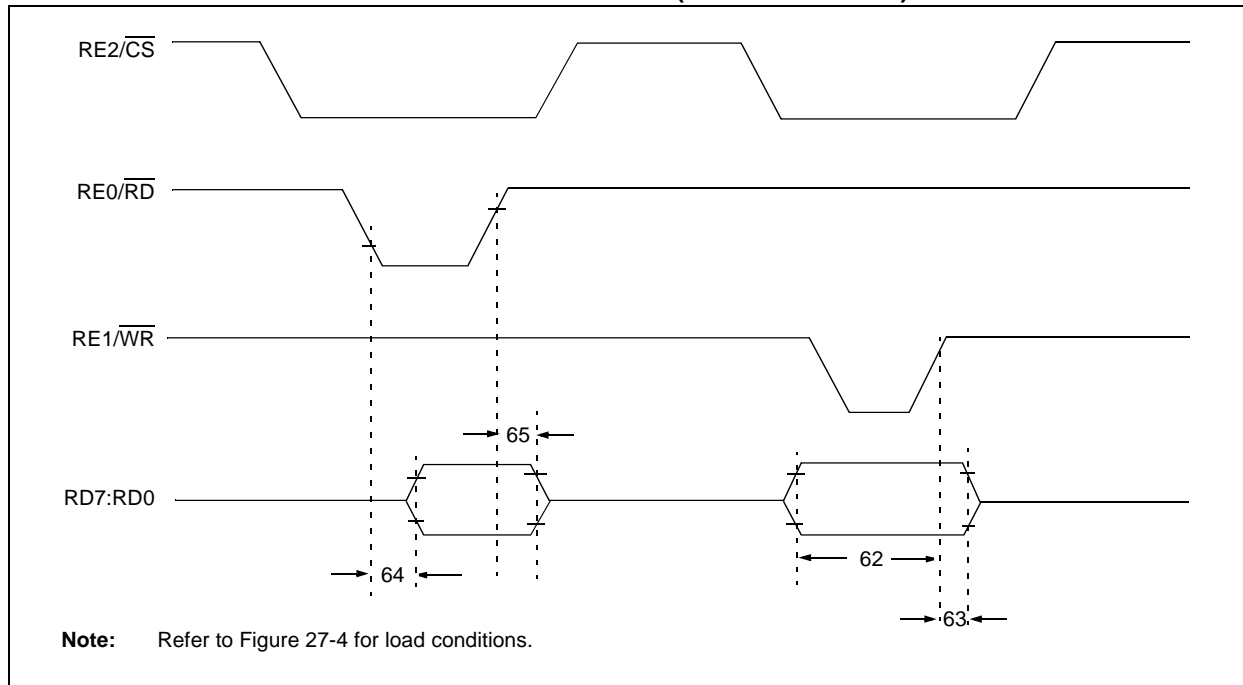

TABLE 27-14: PARALLEL SLAVE PORT REQUIREMENTS (PIC18F8525/8621)

Param. No.	Symbol	Characteristic	Min	Max	Units	Conditions	
62	TdtV2wrH	Data In Valid before $\overline{WR} \uparrow$ or $\overline{CS} \uparrow$ (setup time)	20 25	—	ns	Extended Temp. range	
63	TwrH2dtI	$\overline{WR} \uparrow$ or $\overline{CS} \uparrow$ to Data-in Invalid (hold time)	PIC18F6X2X/8X2X	20	—	ns	
			PIC18LF6X2X/8X2X	35	—	ns	
64	TrdL2dtV	$\overline{RD} \downarrow$ and $\overline{CS} \downarrow$ to Data-out Valid	—	80	ns	Extended Temp. range	
			—	90	ns		
65	TrdH2dtI	$\overline{RD} \uparrow$ or $\overline{CS} \downarrow$ to Data-out Invalid	10	30	ns		
66	TibfINH	Inhibit of the IBF Flag bit being cleared from $\overline{WR} \uparrow$ or $\overline{CS} \uparrow$	—	3 TCY			

PIC18F6525/6621/8525/8621

FIGURE 27-14: EXAMPLE SPI™ MASTER MODE TIMING (CKE = 0)

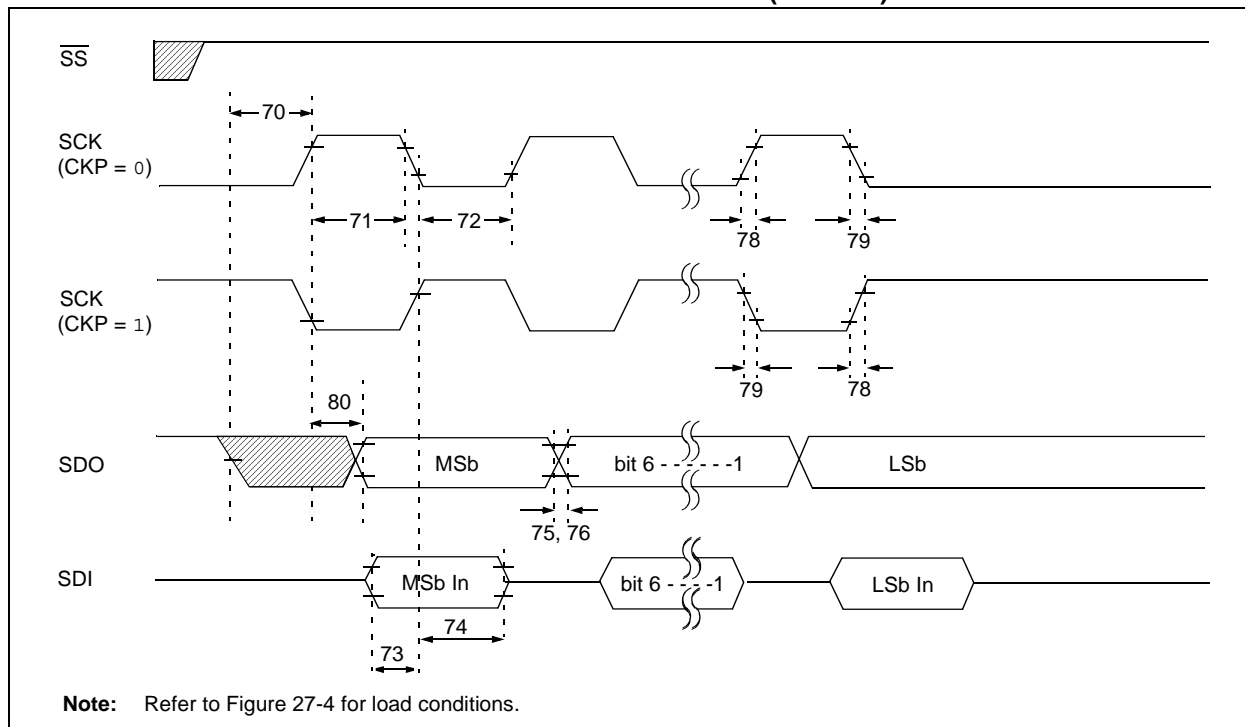

TABLE 27-15: EXAMPLE SPI™ MODE REQUIREMENTS (MASTER MODE, CKE = 0)

Param. No.	Symbol	Characteristic	Min	Max	Units	Conditions
70	TssL2scH, TssL2scL	SS ↓ to SCK ↓ or SCK ↑ Input	T _{CY}	—	ns	
71	TscH	SCK Input High Time (Slave mode)	Continuous	1.25 T _{CY} + 30	—	ns
71A			Single Byte	40	—	ns
72	TscL	SCK Input Low Time (Slave mode)	Continuous	1.25 T _{CY} + 30	—	ns
72A			Single Byte	40	—	ns
73	TdiV2scH, TdiV2scL	Setup Time of SDI Data Input to SCK Edge	100	—	ns	
73A	Tb2B	Last Clock Edge of Byte 1 to the 1st Clock Edge of Byte 2	1.5 T _{CY} + 40	—	ns	(Note 2)
74	Tsch2diL, TscL2diL	Hold Time of SDI Data Input to SCK Edge	100	—	ns	
75	TdoR	SDO Data Output Rise Time	PIC18F6X2X/8X2X	—	25	ns
			PIC18LF6X2X/8X2X	—	45	ns
76	TdoF	SDO Data Output Fall Time	—	25	ns	
78	TscR	SCK Output Rise Time (Master mode)	PIC18F6X2X/8X2X	—	25	ns
			PIC18LF6X2X/8X2X	—	45	ns
79	TscF	SCK Output Fall Time (Master mode)	—	25	ns	
80	Tsch2doV, TscL2doV	SDO Data Output Valid after SCK Edge	PIC18F6X2X/8X2X	—	50	ns
			PIC18LF6X2X/8X2X	—	100	ns

Note 1: Requires the use of Parameter #73A.

Note 2: Only if Parameter #71A and #72A are used.

PIC18F6525/6621/8525/8621

FIGURE 27-15: EXAMPLE SPI™ MASTER MODE TIMING (CKE = 1)

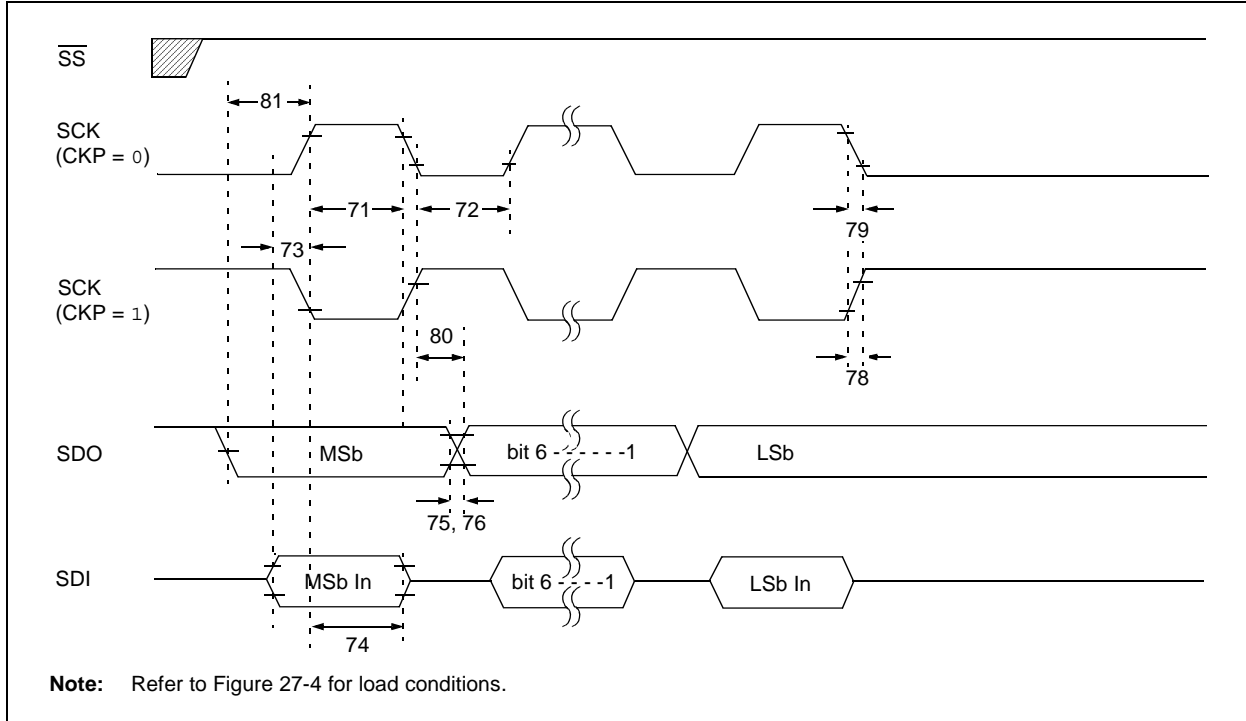

TABLE 27-16: EXAMPLE SPI™ MODE REQUIREMENTS (MASTER MODE, CKE = 1)

Param. No.	Symbol	Characteristic		Min	Max	Units	Conditions
71	Tsch	SCK Input High Time (Slave mode)	Continuous	$1.25 T_{CY} + 30$	—	ns	
71A			Single Byte	40	—	ns	(Note 1)
72	TscL	SCK Input Low Time (Slave mode)	Continuous	$1.25 T_{CY} + 30$	—	ns	
72A			Single Byte	40	—	ns	(Note 1)
73	TdiV2scH, TdiV2scL	Setup Time of SDI Data Input to SCK Edge		100	—	ns	
73A	Tb2B	Last Clock Edge of Byte 1 to the 1st Clock Edge of Byte 2		$1.5 T_{CY} + 40$	—	ns	(Note 2)
74	Tsch2diL, TscL2diL	Hold Time of SDI Data Input to SCK Edge		100	—	ns	
75	TdoR	SDO Data Output Rise Time	PIC18F6X2X/8X2X	—	25	ns	
76			PIC18LF6X2X/8X2X	—	45	ns	
76	TdoF	SDO Data Output Fall Time		—	25	ns	
78	TscR	SCK Output Rise Time (Master mode)	PIC18F6X2X/8X2X	—	25	ns	
79			PIC18LF6X2X/8X2X	—	45	ns	
79	TscF	SCK Output Fall Time (Master mode)		—	25	ns	
80	Tsch2doV, TscL2doV	SDO Data Output Valid after SCK Edge	PIC18F6X2X/8X2X	—	50	ns	
81			PIC18LF6X2X/8X2X	—	100	ns	
81	TdoV2scH, TdoV2scL	SDO Data Output Setup to SCK Edge		T_{CY}	—	ns	

Note 1: Requires the use of Parameter #73A.

Note 2: Only if Parameter #71A and #72A are used.

PIC18F6525/6621/8525/8621

FIGURE 27-16: EXAMPLE SPI™ SLAVE MODE TIMING (CKE = 0)

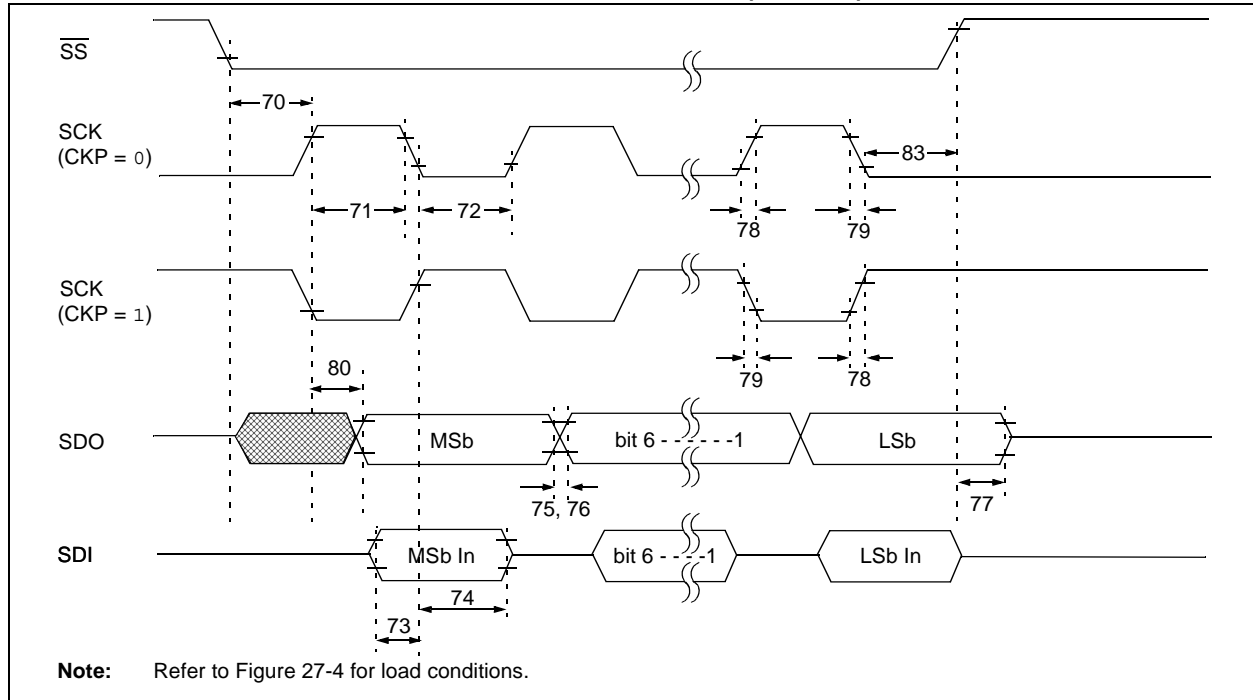

TABLE 27-17: EXAMPLE SPI™ MODE REQUIREMENTS (SLAVE MODE TIMING, CKE = 0)

Param. No.	Symbol	Characteristic	Min	Max	Units	Conditions
70	TssL2scH, TssL2scL	$\overline{SS} \downarrow$ to SCK \downarrow or SCK \uparrow Input	T _{CY}	—	ns	
71 71A	TscH	SCK Input High Time (Slave mode)	Continuous Single Byte	1.25 T _{CY} + 30 40	— ns	(Note 1)
72 72A	TscL	SCK Input Low Time (Slave mode)	Continuous Single Byte	1.25 T _{CY} + 30 40	— ns	(Note 1)
73	TdiV2scH, TdiV2scL	Setup Time of SDI Data Input to SCK Edge	100	—	ns	
73A	Tb2B	Last Clock Edge of Byte 1 to the First Clock Edge of Byte 2	1.5 T _{CY} + 40	—	ns	(Note 2)
74	Tsch2diL, TscL2diL	Hold Time of SDI Data Input to SCK Edge	100	—	ns	
75	TdoR	SDO Data Output Rise Time	PIC18F6X2X/8X2X PIC18F6X2X/8X2X	— 45	25 ns	
76	TdoF	SDO Data Output Fall Time	—	25	ns	
77	TssH2doZ	$\overline{SS} \uparrow$ to SDO Output High-impedance	10	50	ns	
78	TscR	SCK Output Rise Time (Master mode)	PIC18F6X2X/8X2X PIC18F6X2X/8X2X	— 45	25 ns	
79	TscF	SCK Output Fall Time (Master mode)	—	25	ns	
80	Tsch2doV, TscL2doV	SDO Data Output Valid after SCK Edge	PIC18F6X2X/8X2X PIC18F6X2X/8X2X	— 100	50 ns	
83	Tsch2ssH, TscL2ssH	$\overline{SS} \uparrow$ after SCK Edge	1.5 T _{CY} + 40	—	ns	

Note 1: Requires the use of Parameter #73A.
Note 2: Only if Parameter #71A and #72A are used.

PIC18F6525/6621/8525/8621

FIGURE 27-17: EXAMPLE SPI™ SLAVE MODE TIMING (CKE = 1)

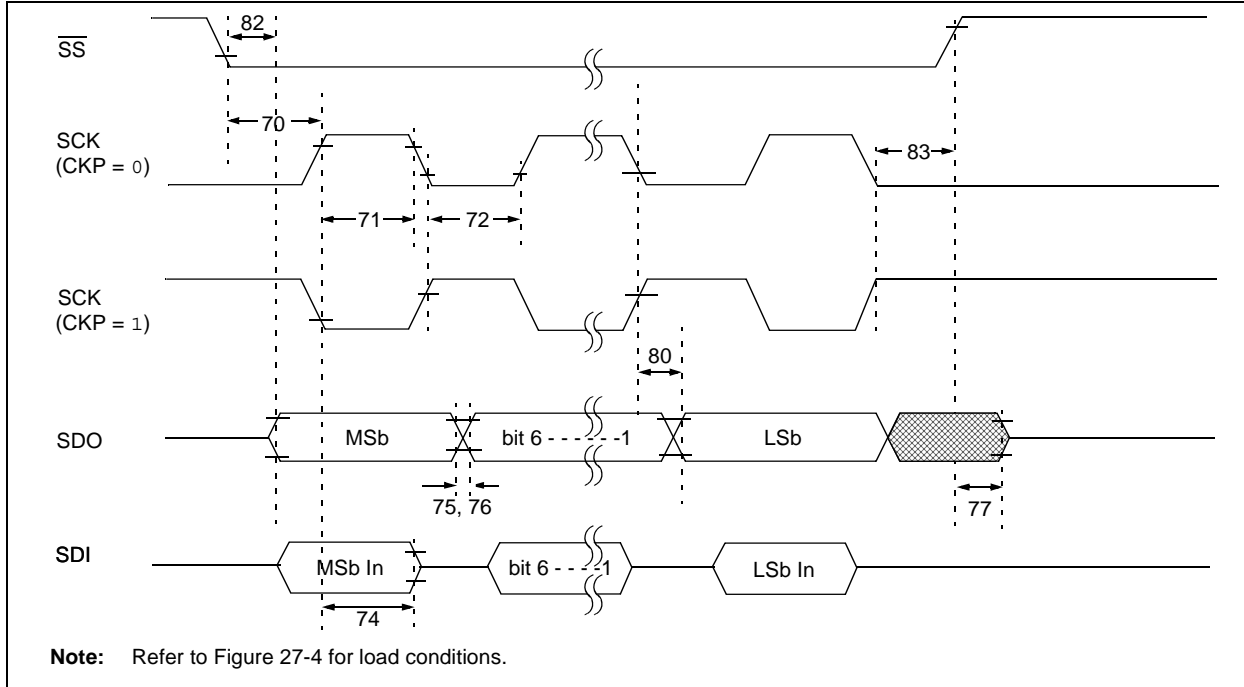

TABLE 27-18: EXAMPLE SPI™ SLAVE MODE REQUIREMENTS (CKE = 1)

Param No.	Symbol	Characteristic	Min	Max	Units	Conditions
70	TssL2scH, TssL2scL	SS ↓ to SCK ↓ or SCK ↑ Input	T _{cy}	—	ns	
71	TscH	SCK Input High Time (Slave mode)	Continuous	1.25 T _{cy} + 30	—	ns
71A			Single Byte	40	—	ns
72	TscL	SCK Input Low Time (Slave mode)	Continuous	1.25 T _{cy} + 30	—	ns
72A			Single Byte	40	—	ns
73A	Tb2B	Last Clock Edge of Byte 1 to the First Clock Edge of Byte 2	1.5 T _{cy} + 40	—	ns	(Note 2)
74	Tsch2diL, TscL2diL	Hold Time of SDI Data Input to SCK Edge	100	—	ns	
75	TdoR	SDO Data Output Rise Time	PIC18F6X2X/8X2X	—	25	ns
76			PIC18LF6X2X/8X2X	—	45	ns
76	TdoF	SDO Data Output Fall Time	—	25	ns	
77	TssH2doZ	SS ↑ to SDO Output High-impedance	10	50	ns	
78	TscR	SCK Output Rise Time (Master mode)	PIC18F6X2X/8X2X	—	25	ns
79			PIC18LF6X2X/8X2X	—	45	ns
79	TscF	SCK Output Fall Time (Master mode)	—	25	ns	
80	Tsch2doV, TscL2doV	SDO Data Output Valid after SCK Edge	PIC18F6X2X/8X2X	—	50	ns
82			PIC18LF6X2X/8X2X	—	100	ns
82	TssL2doV	SDO Data Output Valid after SS ↓ Edge	PIC18F6X2X/8X2X	—	50	ns
83			PIC18LF6X2X/8X2X	—	100	ns
83	Tsch2ssH, TscL2ssH	SS ↑ after SCK Edge	1.5 T _{cy} + 40	—	ns	

Note 1: Requires the use of Parameter #73A.

Note 2: Only if Parameter #71A and #72A are used.

PIC18F6525/6621/8525/8621

FIGURE 27-18: I²C™ BUS START/STOP BITS TIMING

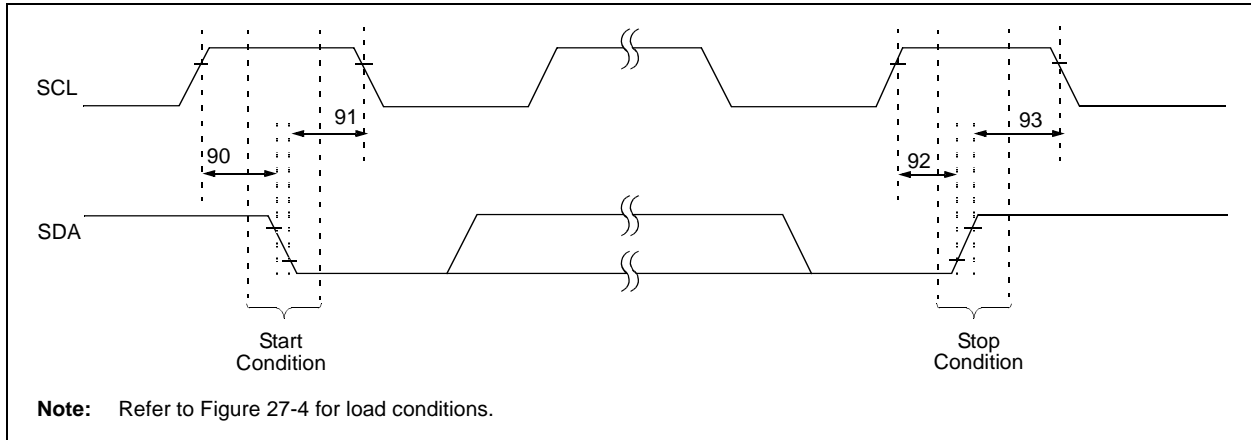
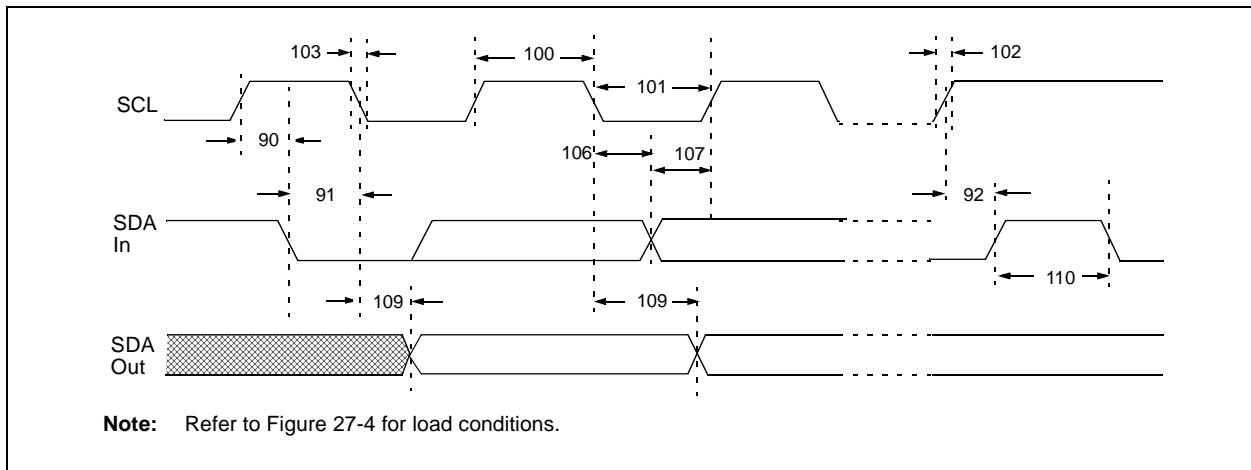

TABLE 27-19: I²C™ BUS START/STOP BITS REQUIREMENTS (SLAVE MODE)

Param. No.	Symbol	Characteristic		Min	Max	Units	Conditions
90	TSU:STA	Start Condition Setup Time	100 kHz mode	4700	—	ns	Only relevant for Repeated Start condition
			400 kHz mode	600	—		
91	THD:STA	Start Condition Hold Time	100 kHz mode	4000	—	ns	After this period, the first clock pulse is generated
			400 kHz mode	600	—		
92	TSU:STO	Stop Condition Setup Time	100 kHz mode	4700	—	ns	
			400 kHz mode	600	—		
93	THD:STO	Stop Condition Hold Time	100 kHz mode	4000	—	ns	
			400 kHz mode	600	—		

FIGURE 27-19: I²C™ BUS DATA TIMING



PIC18F6525/6621/8525/8621

TABLE 27-20: I²C™ BUS DATA REQUIREMENTS (SLAVE MODE)

Param. No.	Symbol	Characteristic		Min	Max	Units	Conditions	
100	THIGH	Clock High Time	100 kHz mode	4.0	—	μs	PIC18F6X2X/8X2X must operate at a minimum of 1.5 MHz	
			400 kHz mode	0.6	—	μs		PIC18F6X2X/8X2X must operate at a minimum of 10 MHz
			MSSP module	1.5 T _{CY}	—			
101	TLOW	Clock Low Time	100 kHz mode	4.7	—	μs	PIC18F6X2X/8X2X must operate at a minimum of 1.5 MHz	
			400 kHz mode	1.3	—	μs		PIC18F6X2X/8X2X must operate at a minimum of 10 MHz
			MSSP module	1.5 T _{CY}	—			
102	TR	SDA and SCL Rise Time	100 kHz mode	—	1000	ns	CB is specified to be from 10 to 400 pF	
			400 kHz mode	20 + 0.1 C _B	300	ns		
103	TF	SDA and SCL Fall Time	100 kHz mode	—	300	ns	CB is specified to be from 10 to 400 pF	
			400 kHz mode	20 + 0.1 C _B	300	ns		
90	TSU:STA	Start Condition Setup Time	100 kHz mode	4.7	—	μs	Only relevant for Repeated Start condition	
			400 kHz mode	0.6	—	μs		
91	THD:STA	Start Condition Hold Time	100 kHz mode	4.0	—	μs	After this period, the first clock pulse is generated	
			400 kHz mode	0.6	—	μs		
106	THD:DAT	Data Input Hold Time	100 kHz mode	0	—	ns		
			400 kHz mode	0	0.9	μs		
107	TSU:DAT	Data Input Setup Time	100 kHz mode	250	—	ns	(Note 2)	
			400 kHz mode	100	—	ns		
92	TSU:STO	Stop Condition Setup Time	100 kHz mode	4.7	—	μs		
			400 kHz mode	0.6	—	μs		
109	TAA	Output Valid from Clock	100 kHz mode	—	3500	ns	(Note 1)	
			400 kHz mode	—	—	ns		
110	TBUF	Bus Free Time	100 kHz mode	4.7	—	μs	Time the bus must be free before a new transmission can start	
			400 kHz mode	1.3	—	μs		
D102	CB	Bus Capacitive Loading		—	400	pF		

Note 1: As a transmitter, the device must provide this internal minimum delay time to bridge the undefined region (min. 300 ns) of the falling edge of SCL to avoid unintended generation of Start or Stop conditions.

- 2:** A Fast mode I²C™ bus device can be used in a Standard mode I²C bus system but the requirement TSU:DAT ≥ 250 ns must then be met. This will automatically be the case if the device does not stretch the low period of the SCL signal. If such a device does stretch the low period of the SCL signal, it must output the next data bit to the SDA line.

TR max. + TSU:DAT = 1000 + 250 = 1250 ns (according to the Standard mode I²C bus specification) before the SCL line is released.

PIC18F6525/6621/8525/8621

FIGURE 27-20: MASTER SSP I²C™ BUS START/STOP BITS TIMING WAVEFORMS

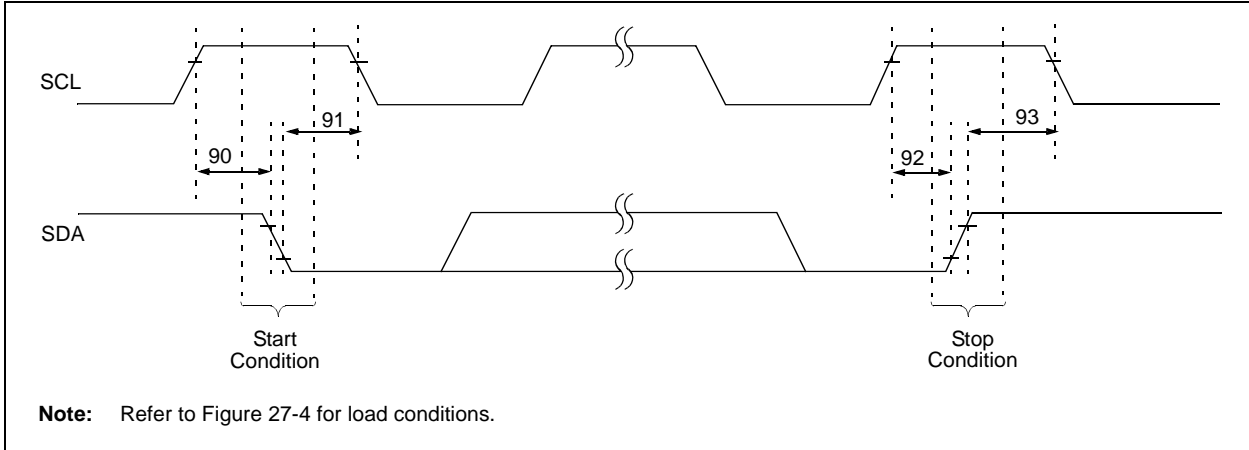
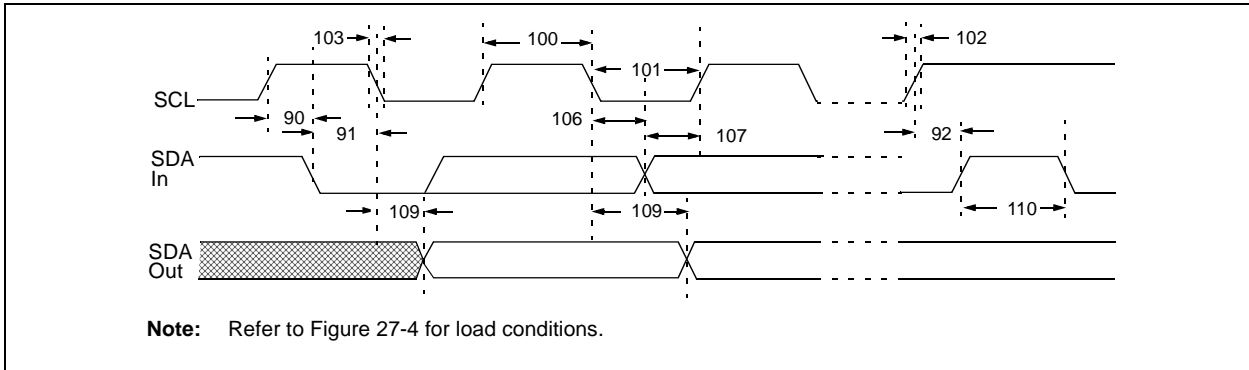

TABLE 27-21: MASTER SSP I²C™ BUS START/STOP BITS REQUIREMENTS

Param. No.	Symbol	Characteristic	Min	Max	Units	Conditions
90	TSU:STA	Start Condition Setup Time	100 kHz mode	$2(T_{osc})(BRG + 1)$	—	ns Only relevant for Repeated Start condition
			400 kHz mode	$2(T_{osc})(BRG + 1)$	—	
			1 MHz mode ⁽¹⁾	$2(T_{osc})(BRG + 1)$	—	
91	THD:STA	Start Condition Hold Time	100 kHz mode	$2(T_{osc})(BRG + 1)$	—	ns After this period, the first clock pulse is generated
			400 kHz mode	$2(T_{osc})(BRG + 1)$	—	
			1 MHz mode ⁽¹⁾	$2(T_{osc})(BRG + 1)$	—	
92	TSU:STO	Stop Condition Setup Time	100 kHz mode	$2(T_{osc})(BRG + 1)$	—	ns
			400 kHz mode	$2(T_{osc})(BRG + 1)$	—	
			1 MHz mode ⁽¹⁾	$2(T_{osc})(BRG + 1)$	—	
93	THD:STO	Stop Condition Hold Time	100 kHz mode	$2(T_{osc})(BRG + 1)$	—	ns
			400 kHz mode	$2(T_{osc})(BRG + 1)$	—	
			1 MHz mode ⁽¹⁾	$2(T_{osc})(BRG + 1)$	—	

Note 1: Maximum pin capacitance = 10 pF for all I²C pins.

FIGURE 27-21: MASTER SSP I²C™ BUS DATA TIMING



PIC18F6525/6621/8525/8621

TABLE 27-22: MASTER SSP I²C™ BUS DATA REQUIREMENTS

Param. No.	Symbol	Characteristic	Min	Max	Units	Conditions
100	THIGH	Clock High Time	100 kHz mode	2(Tosc)(BRG + 1)	—	ms
			400 kHz mode	2(Tosc)(BRG + 1)	—	ms
			1 MHz mode ⁽¹⁾	2(Tosc)(BRG + 1)	—	ms
101	TLOW	Clock Low Time	100 kHz mode	2(Tosc)(BRG + 1)	—	ms
			400 kHz mode	2(Tosc)(BRG + 1)	—	ms
			1 MHz mode ⁽¹⁾	2(Tosc)(BRG + 1)	—	ms
102	TR	SDA and SCL Rise Time	100 kHz mode	—	1000	ns
			400 kHz mode	20 + 0.1 Cb	300	ns
			1 MHz mode ⁽¹⁾	—	300	ns
103	TF	SDA and SCL Fall Time	100 kHz mode	—	300	ns
			400 kHz mode	20 + 0.1 Cb	300	ns
			1 MHz mode ⁽¹⁾	—	100	ns
90	TSU:STA	Start Condition Setup Time	100 kHz mode	2(Tosc)(BRG + 1)	—	ms
			400 kHz mode	2(Tosc)(BRG + 1)	—	ms
			1 MHz mode ⁽¹⁾	2(Tosc)(BRG + 1)	—	ms
91	THD:STA	Start Condition Hold Time	100 kHz mode	2(Tosc)(BRG + 1)	—	ms
			400 kHz mode	2(Tosc)(BRG + 1)	—	ms
			1 MHz mode ⁽¹⁾	2(Tosc)(BRG + 1)	—	ms
106	THD:DAT	Data Input Hold Time	100 kHz mode	0	—	ns
			400 kHz mode	0	0.9	ms
			1 MHz mode ⁽¹⁾	TBD	—	ns
107	TSU:DAT	Data Input Setup Time	100 kHz mode	250	—	ns
			400 kHz mode	100	—	ns
			1 MHz mode ⁽¹⁾	TBD	—	ns
92	TSU:STO	Stop Condition Setup Time	100 kHz mode	2(Tosc)(BRG + 1)	—	ms
			400 kHz mode	2(Tosc)(BRG + 1)	—	ms
			1 MHz mode ⁽¹⁾	2(Tosc)(BRG + 1)	—	ms
109	TAA	Output Valid from Clock	100 kHz mode	—	3500	ns
			400 kHz mode	—	1000	ns
			1 MHz mode ⁽¹⁾	—	—	ns
110	TBUF	Bus Free Time	100 kHz mode	4.7	—	ms
			400 kHz mode	1.3	—	ms
			1 MHz mode ⁽¹⁾	TBD	—	ms
D102	CB	Bus Capacitive Loading	—	400	pF	

Legend: TBD = To Be Determined

Note 1: Maximum pin capacitance = 10 pF for all I²C™ pins.

- 2:** A Fast mode I²C bus device can be used in a Standard mode I²C bus system but parameter #107 ≥ 250 ns must then be met. This will automatically be the case if the device does not stretch the low period of the SCL signal. If such a device does stretch the low period of the SCL signal, it must output the next data bit to the SDA line, parameter #102.+ parameter #107 = 1000 + 250 = 1250 ns (for 100 kHz mode), before the SCL line is released.

PIC18F6525/6621/8525/8621

FIGURE 27-22: EUSART SYNCHRONOUS TRANSMISSION (MASTER/SLAVE) TIMING

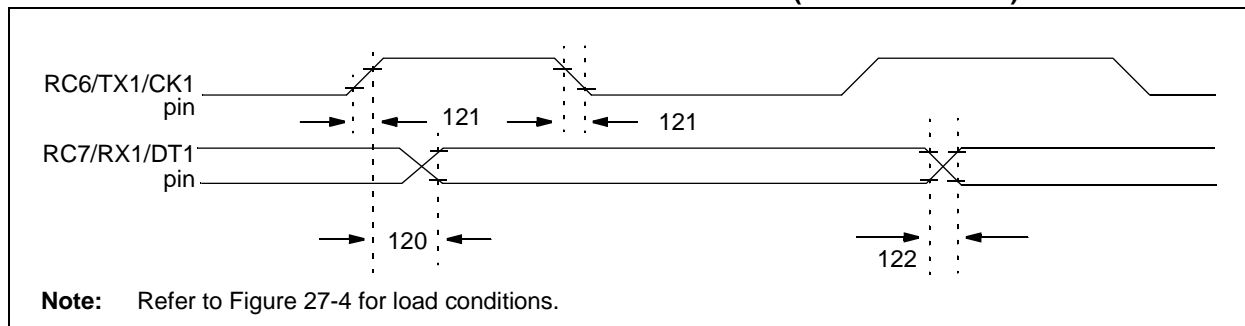

TABLE 27-23: EUSART SYNCHRONOUS TRANSMISSION REQUIREMENTS

Param. No.	Symbol	Characteristic	Min	Max	Units	Conditions
120	TckH2dtV	SYNC XMIT (Master and Slave) Clock High to Data Out Valid	PIC18F6X2X/8X2X	—	40	ns
			PIC18LF6X2X/8X2X	—	100	ns
121	Tckrf	Clock Out Rise Time and Fall Time (Master mode)	PIC18F6X2X/8X2X	—	20	ns
			PIC18LF6X2X/8X2X	—	50	ns
122	Tdtrf	Data Out Rise Time and Fall Time	PIC18F6X2X/8X2X	—	20	ns
			PIC18LF6X2X/8X2X	—	50	ns

FIGURE 27-23: EUSART SYNCHRONOUS RECEIVE (MASTER/SLAVE) TIMING

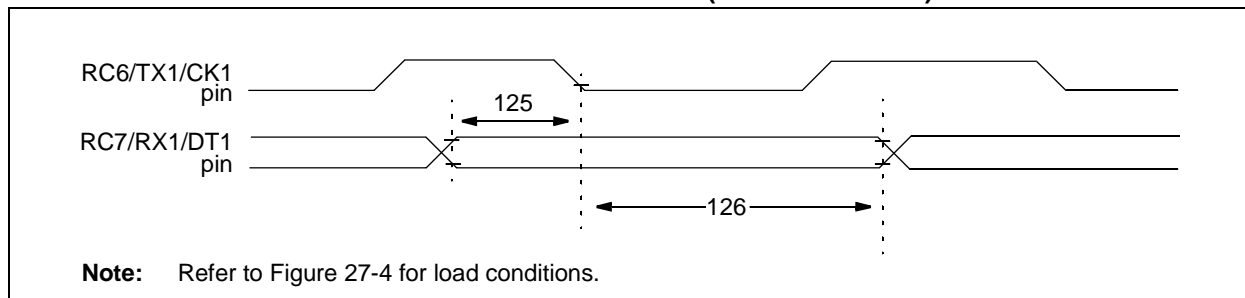

TABLE 27-24: EUSART SYNCHRONOUS RECEIVE REQUIREMENTS

Param. No.	Symbol	Characteristic	Min	Max	Units	Conditions
125	TdtV2ckl	SYNC RCV (Master and Slave) Data Hold before CKx ↓ (DTx hold time)	10	—	ns	
126	TckL2dtl	Data Hold after CKx ↓ (DTx hold time)	15	—	ns	

PIC18F6525/6621/8525/8621

**TABLE 27-25: A/D CONVERTER CHARACTERISTICS: PIC18F6X2X/8X2X (INDUSTRIAL, EXTENDED)
PIC18LF6X2X/8X2X (INDUSTRIAL)**

Param No.	Symbol	Characteristic	Min	Typ	Max	Units	Conditions
A01	NR	Resolution	— —	— —	10 TBD	bit bit	VREF = VDD ≥ 3.0V VREF = VDD < 3.0V
A03	EIL	Integral Linearity Error	— —	— —	<±1 TBD	LSb LSb	VREF = VDD ≥ 3.0V VREF = VDD < 3.0V
A04	EDL	Differential Linearity Error	— —	— —	<±1 TBD	LSb LSb	VREF = VDD ≥ 3.0V VREF = VDD < 3.0V
A05	EFS	Full Scale Error	— —	— —	<±1 TBD	LSb LSb	VREF = VDD ≥ 3.0V VREF = VDD < 3.0V
A06	E0FF	Offset Error	— —	— —	<±1 TBD	LSb LSb	VREF = VDD ≥ 3.0V VREF = VDD < 3.0V
A10	—	Monotonicity	guaranteed ⁽³⁾			—	VSS ≤ VAIN ≤ VREF
A20	VREF	Reference Voltage	0V	—	—	V	For 10-bit resolution
A20A		(VREFH – VREFL)	3V	—	—	V	
A21	VREFH	Reference Voltage High	AVSS	—	AVDD + 0.3V	V	
A22	VREFL	Reference Voltage Low	AVSS – 0.3V	—	AVDD	V	
A25	VAIN	Analog Input Voltage	AVSS – 0.3V	—	VREF + 0.3V	V	
A30	ZAIN	Recommended Impedance of Analog Voltage Source	—	—	10.0	kΩ	
A40	IAD	A/D Conversion Current (VDD)					Average current consumption when A/D is on (Note 1)
		PIC18F6X2X/8X2X	—	180	—	μA	
		PIC18LF6X2X/8X2X	—	90	—	μA	
A50	IREF	VREF Input Current (Note 2)	— —	— —	5 150	μA μA	During VAIN acquisition. During A/D conversion cycle.

Legend: TBD = To Be Determined

Note 1: When A/D is off, it will not consume any current other than minor leakage current. The power-down current spec includes any such leakage from the A/D module.

VREF current is from RA2/AN2/VREF- and RA3/AN3/VREF+ pins or AVDD and AVSS pins, whichever is selected as reference input.

2: VSS ≤ VAIN ≤ VREF

3: The A/D conversion result never decreases with an increase in the input voltage and has no missing codes.

PIC18F6525/6621/8525/8621

FIGURE 27-24: A/D CONVERSION TIMING

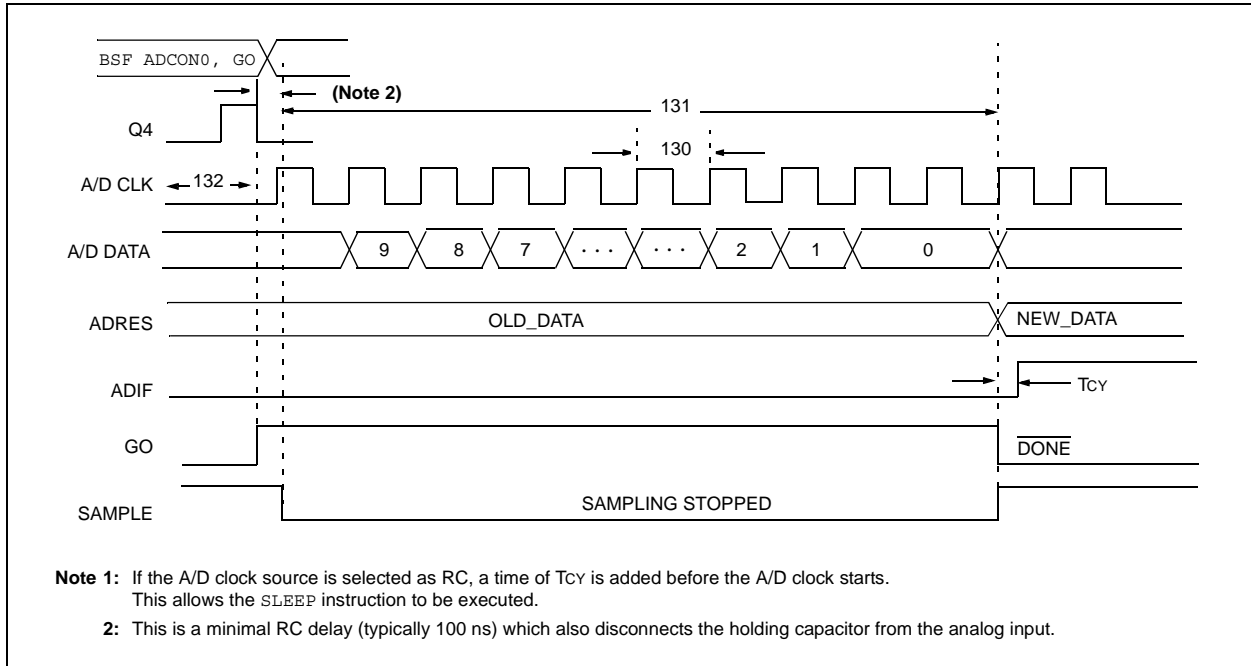

TABLE 27-26: A/D CONVERSION REQUIREMENTS

Param. No.	Symbol	Characteristic	Min	Max	Units	Conditions	
130	TAD	A/D Clock Period	PIC18F6X2X/8X2X	1.6	20 ⁽⁵⁾	μs	TOSC based, VREF ≥ 3.0V
			PIC18LF6X2X/8X2X	3.0	20 ⁽⁵⁾	μs	TOSC based, VREF full range
		PIC18F6X2X/8X2X	2.0	6.0	μs	A/D RC mode	
		PIC18LF6X2X/8X2X	3.0	9.0	μs	A/D RC mode	
131	TCNV	Conversion Time (not including acquisition time) (Note 1)	11	12	TAD		
132	TACQ	Acquisition Time (Note 3)	15	—	μs	-40°C ≤ Temp ≤ +125°C	
			10	—	μs	0°C ≤ Temp ≤ +125°C	
135	TSWC	Switching Time from Convert → Sample	—	(Note 4)			
136	TAMP	Amplifier Settling Time (Note 2)	1	—	μs	This may be used if the “new” input voltage has not changed by more than 1 LSb (i.e., 5 mV @ 5.12V) from the last sampled voltage (as stated on CHOLD).	

- Note 1:** ADRES register may be read on the following TCY cycle.
- 2:** See **Section 20.0 “10-Bit Analog-to-Digital Converter (A/D) Module”** for minimum conditions when input voltage has changed more than 1 LSb.
- 3:** The time for the holding capacitor to acquire the “New” input voltage when the voltage changes full scale after the conversion (AVDD to AVSS, or AVSS to AVDD). The source impedance (RS) on the input channels is 50Ω.
- 4:** On the next Q4 cycle of the device clock.
- 5:** The time of the A/D clock period is dependent on the device frequency and the TAD clock divider.

PIC18F6525/6621/8525/8621

NOTES:

PIC18F6525/6621/8525/8621

28.0 DC AND AC CHARACTERISTICS GRAPHS AND TABLES

Note: The graphs and tables provided following this note are a statistical summary based on a limited number of samples and are provided for informational purposes only. The performance characteristics listed herein are not tested or guaranteed. In some graphs or tables, the data presented may be outside the specified operating range (e.g., outside specified power supply range) and therefore, outside the warranted range.

“Typical” represents the mean of the distribution at 25°C. “Maximum” or “minimum” represents (mean + 3 σ) or (mean – 3 σ) respectively, where σ is a standard deviation, over the whole temperature range.

FIGURE 28-1: TYPICAL I_{DD} vs. F_{osc} OVER V_{DD} (HS MODE)

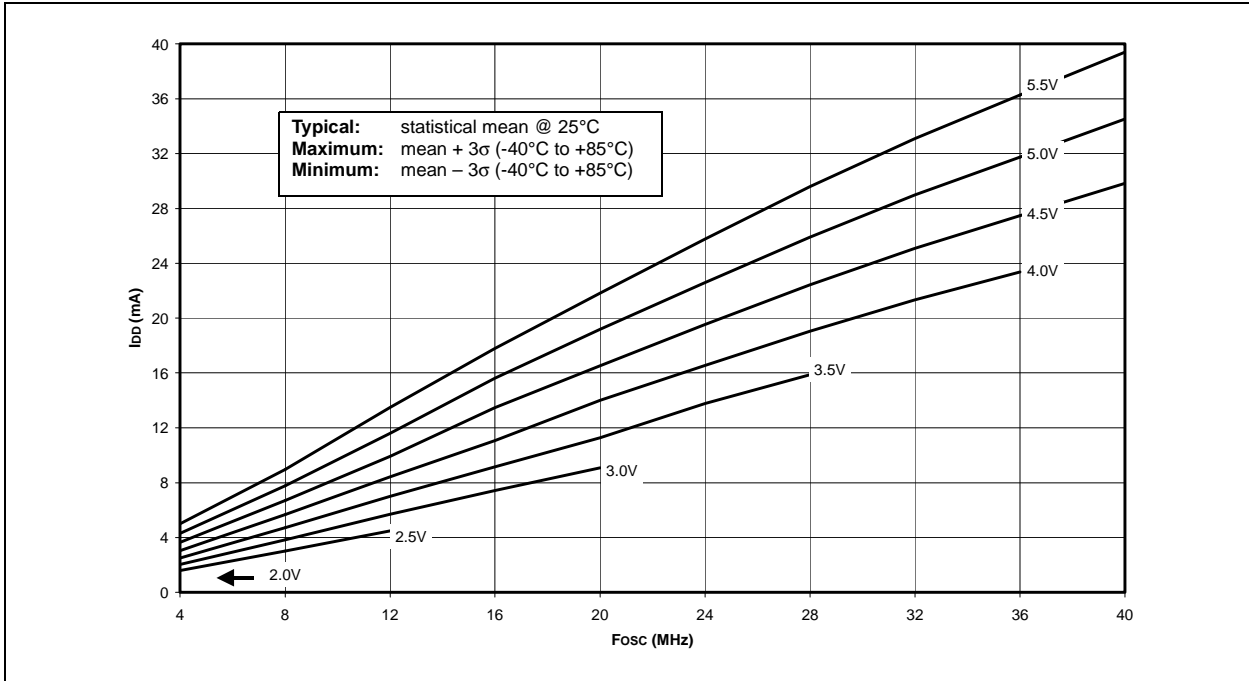
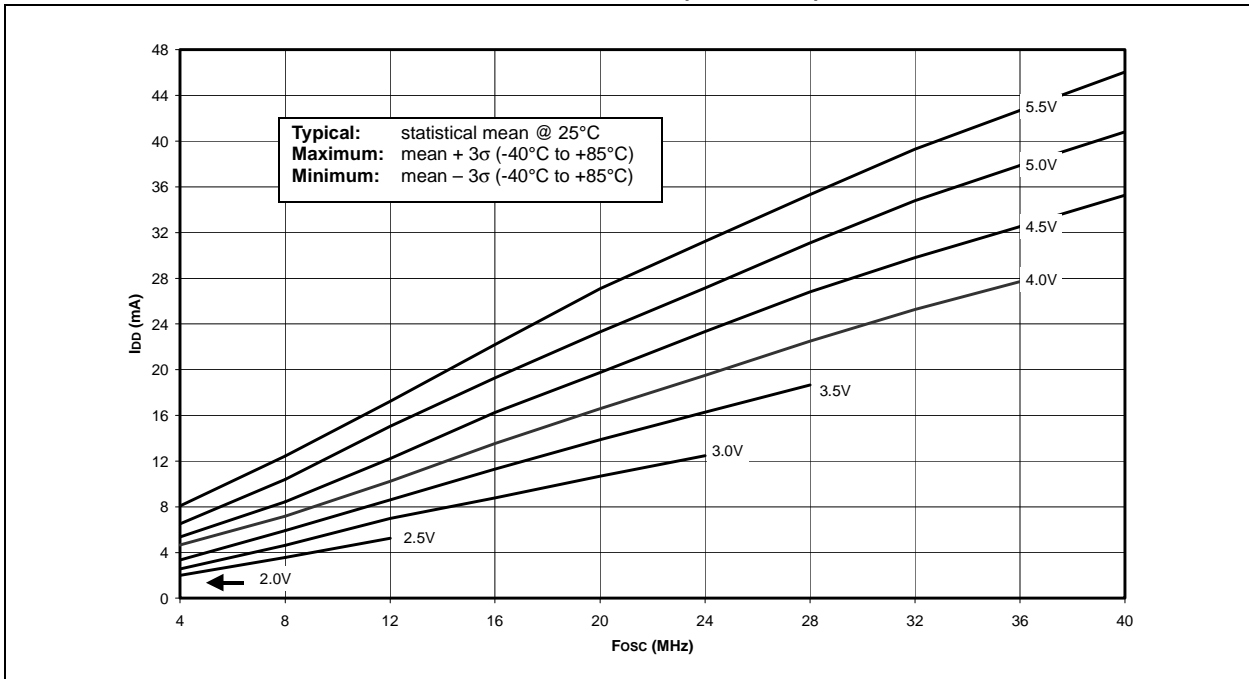

FIGURE 28-2: MAXIMUM I_{DD} vs. F_{osc} OVER V_{DD} (HS MODE)



PIC18F6525/6621/8525/8621

FIGURE 28-3: TYPICAL I_{DD} vs. F_{OSC} OVER V_{DD} (HS/PLL MODE)

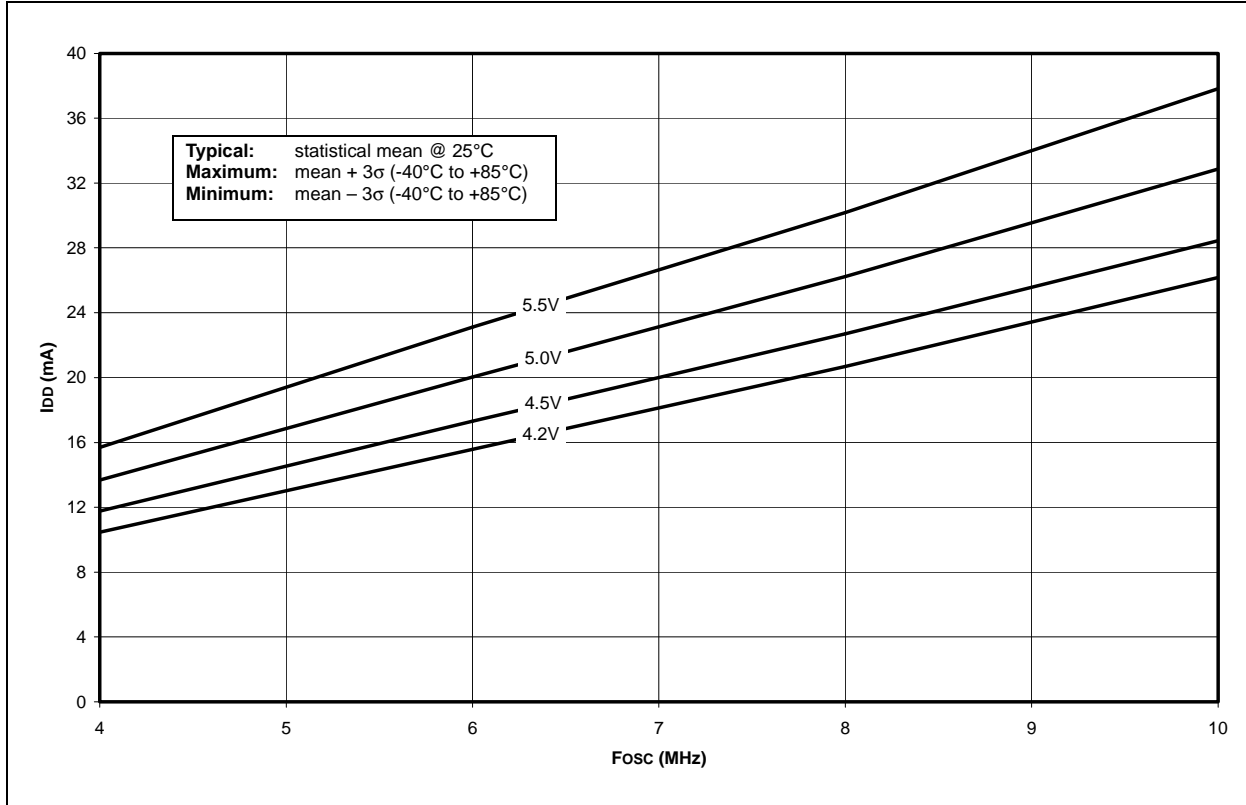
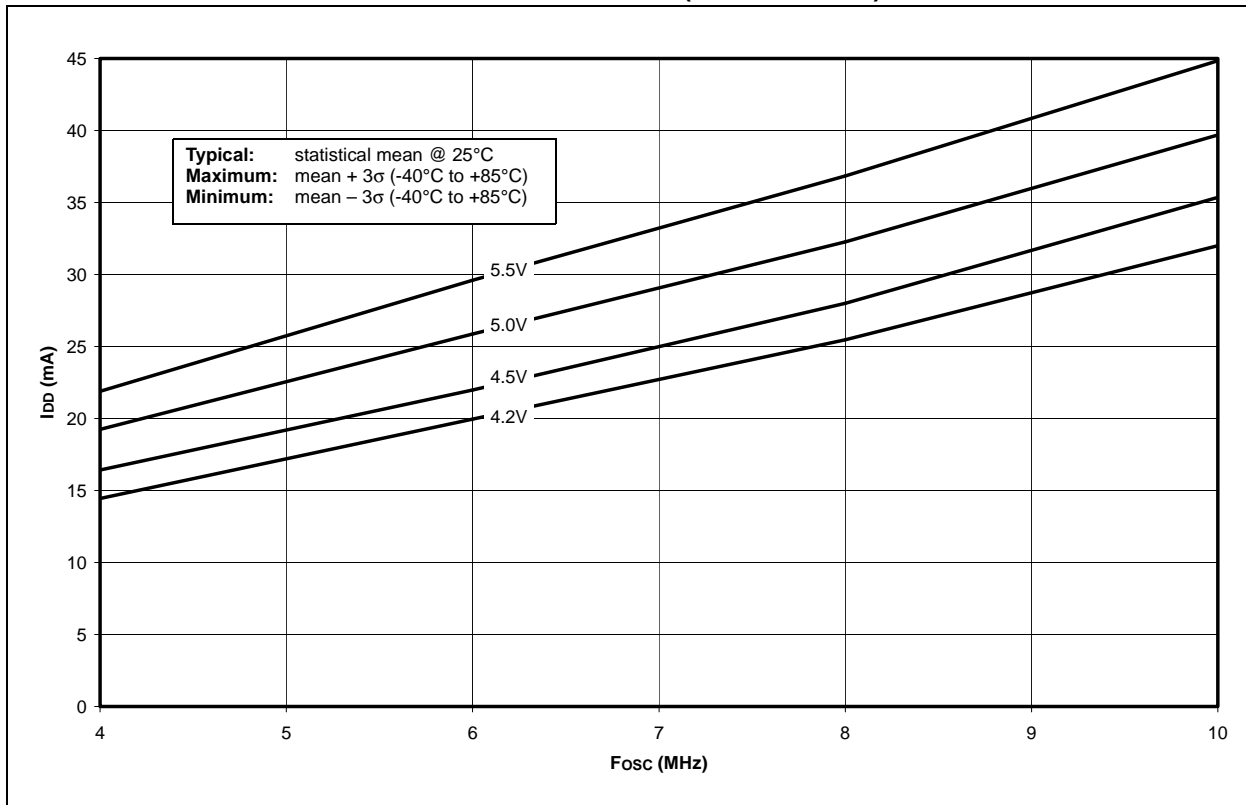

FIGURE 28-4: MAXIMUM I_{DD} vs. F_{OSC} OVER V_{DD} (HS/PLL MODE)



PIC18F6525/6621/8525/8621

FIGURE 28-5: TYPICAL I_{DD} vs. Fosc OVER V_{DD} (XT MODE)

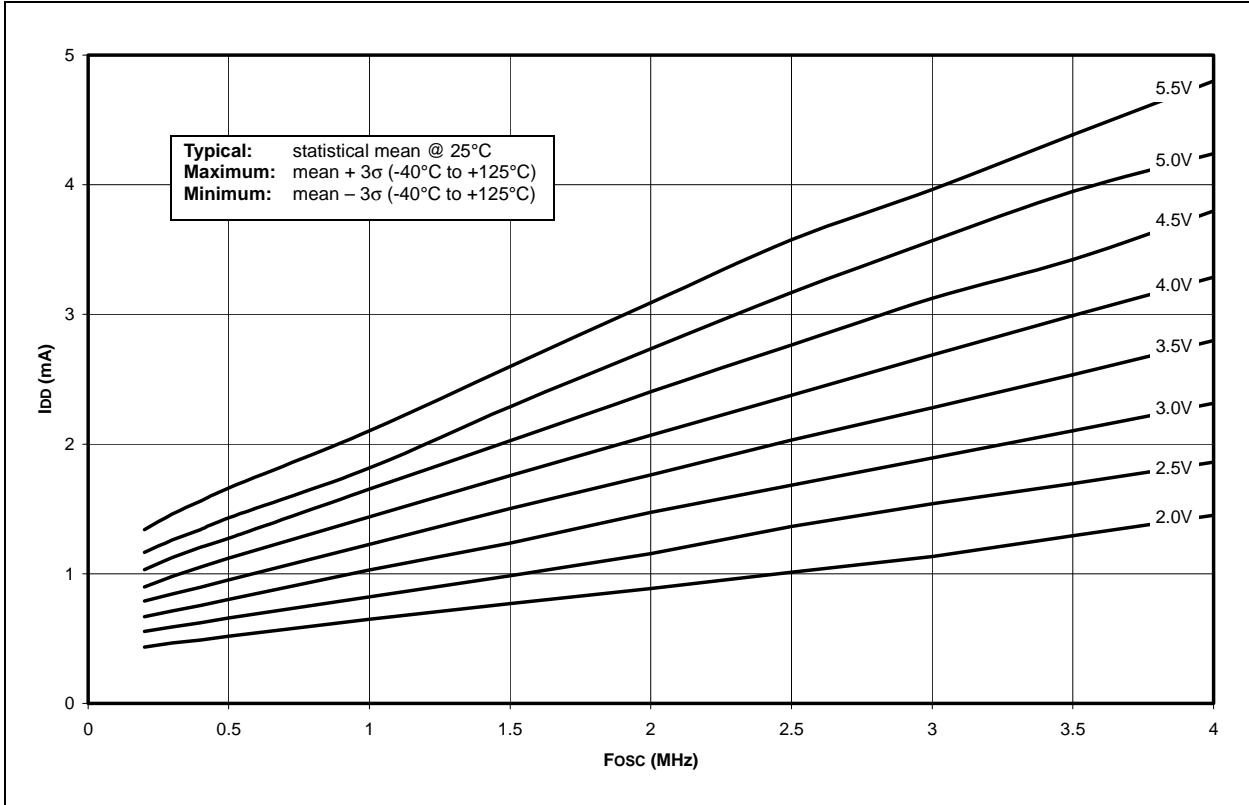
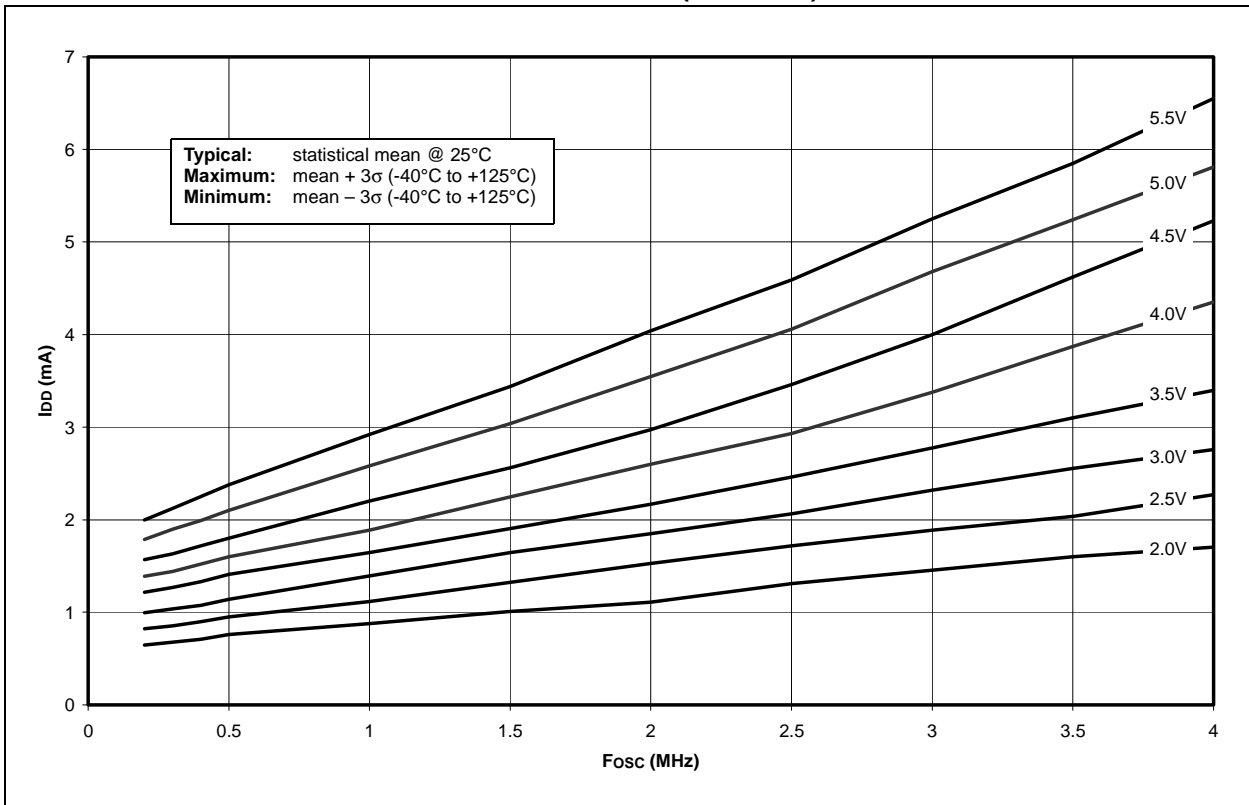

FIGURE 28-6: MAXIMUM I_{DD} vs. Fosc OVER V_{DD} (XT MODE)



PIC18F6525/6621/8525/8621

FIGURE 28-7: TYPICAL I_{DD} vs. Fosc OVER V_{DD} (LP MODE)

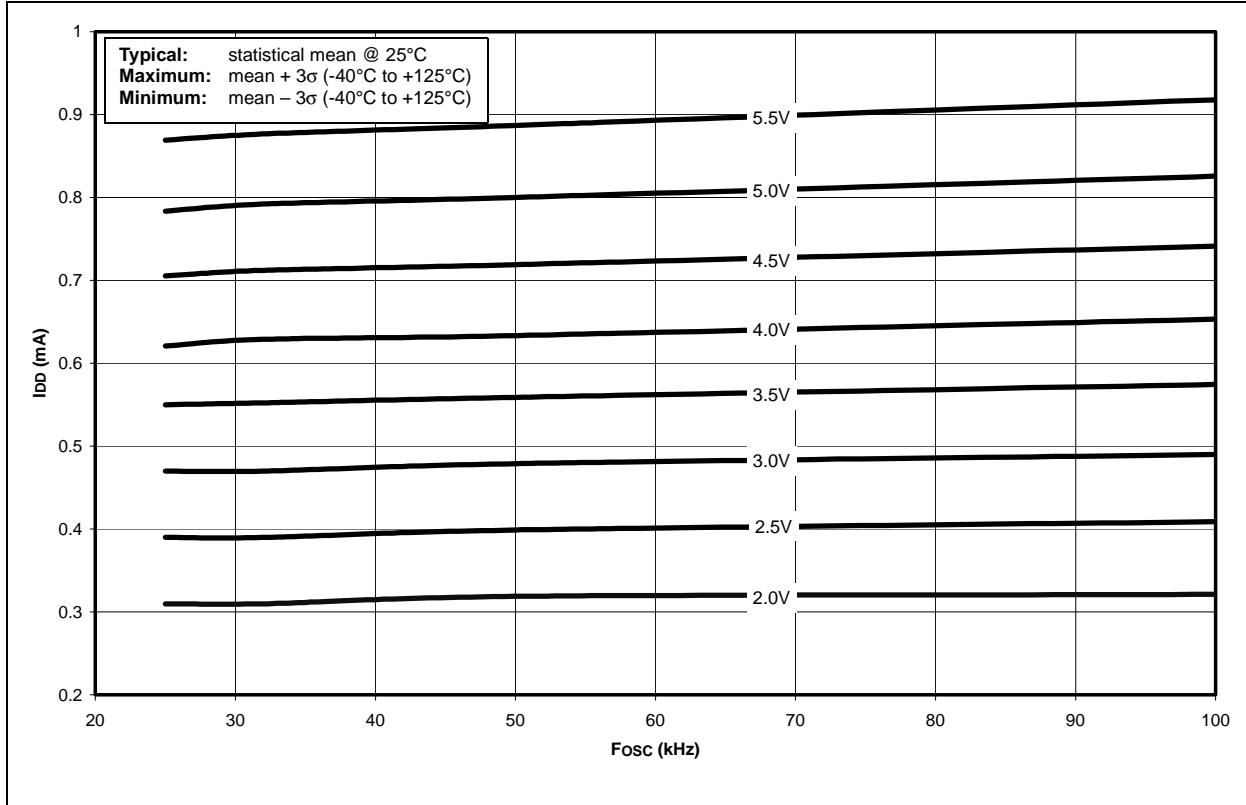
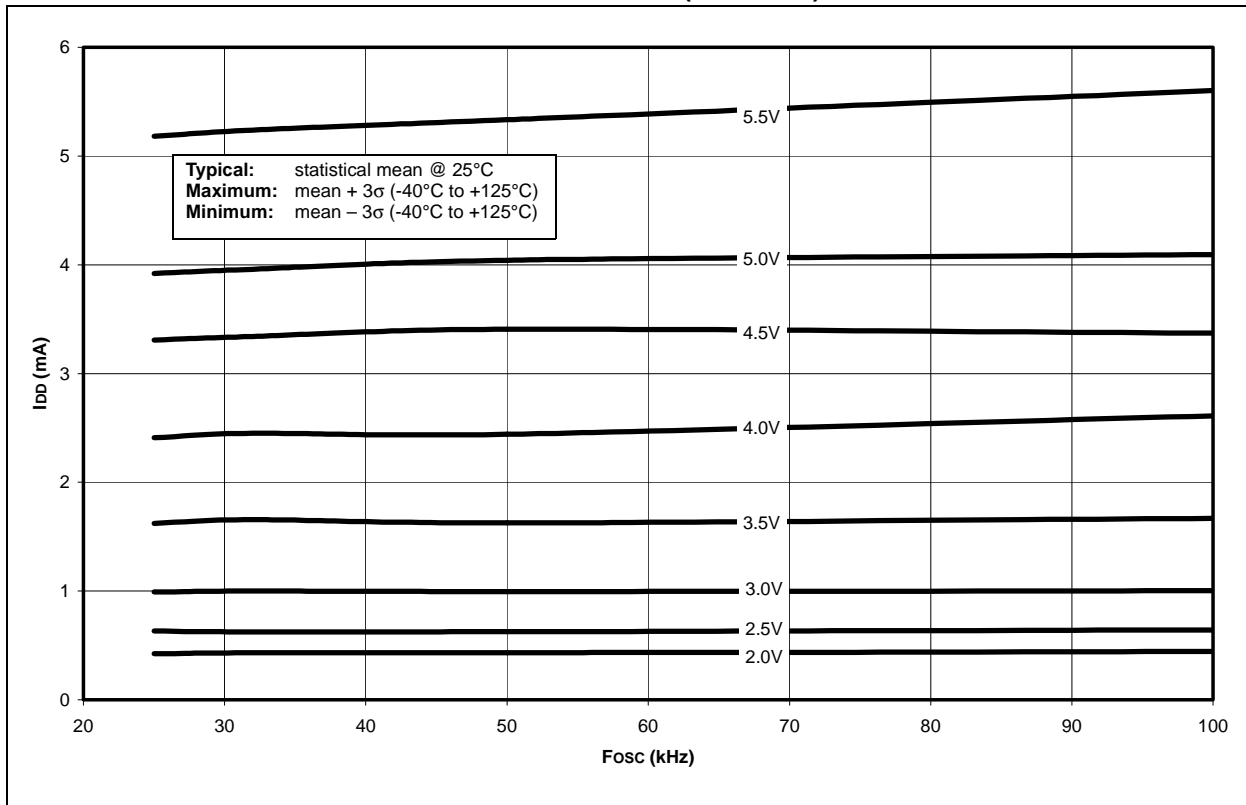

FIGURE 28-8: MAXIMUM I_{DD} vs. Fosc OVER V_{DD} (LP MODE)



PIC18F6525/6621/8525/8621

FIGURE 28-9: TYPICAL I_{DD} vs. F_{osc} OVER V_{DD} (EC MODE)

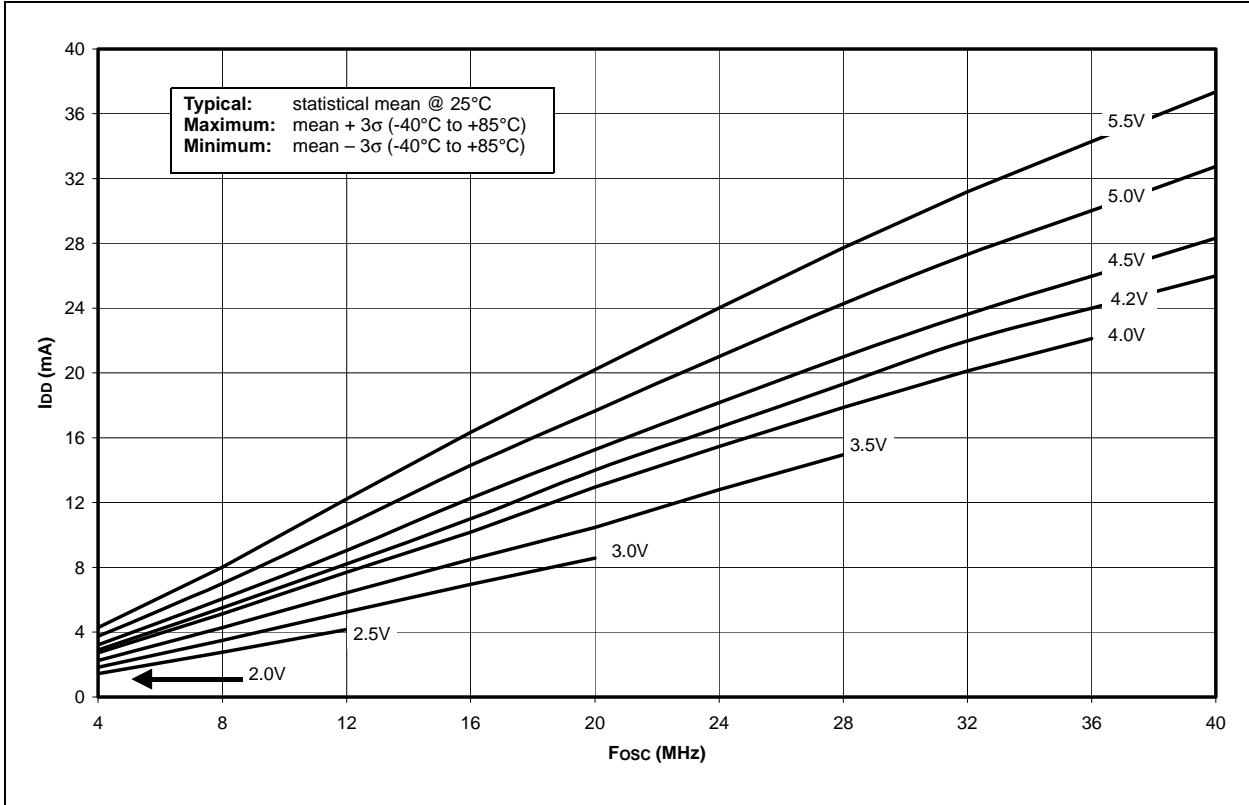
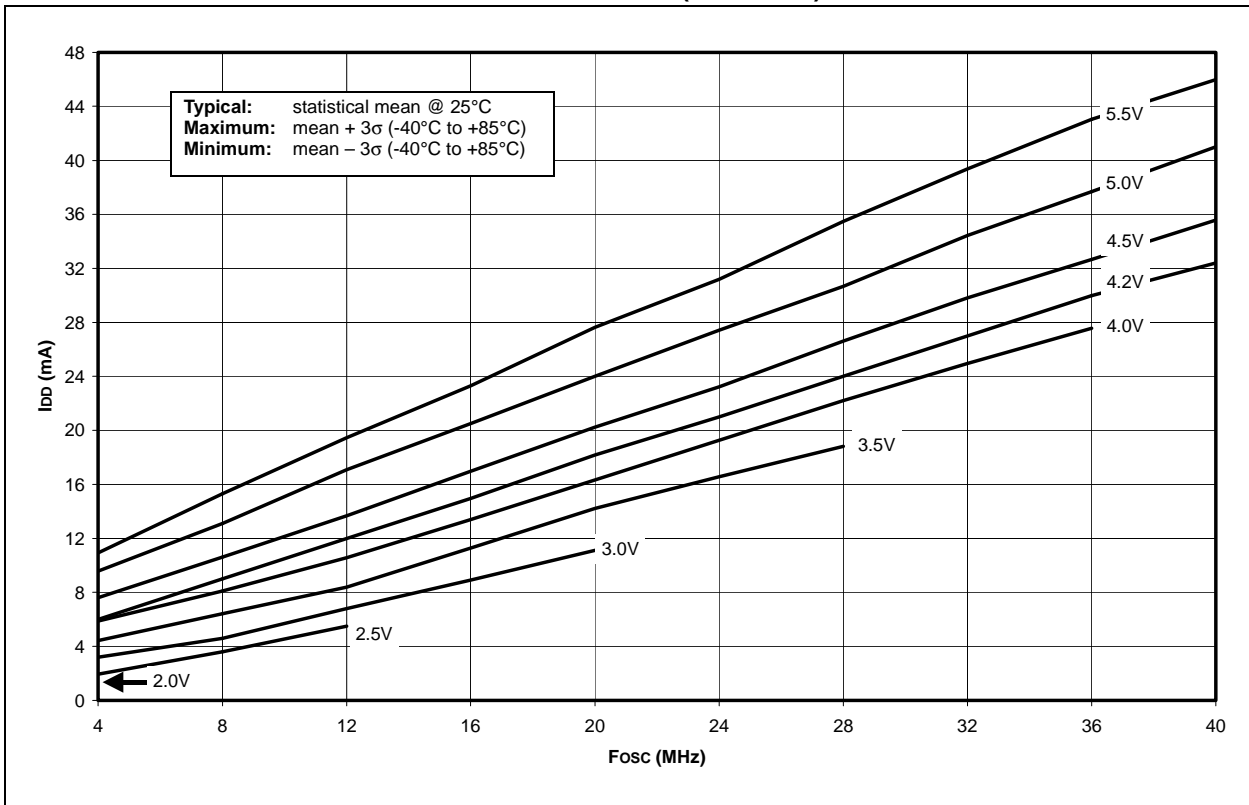

FIGURE 28-10: MAXIMUM I_{DD} vs. F_{osc} OVER V_{DD} (EC MODE)



PIC18F6525/6621/8525/8621

FIGURE 28-11: TYPICAL AND MAXIMUM I_{T1OSC} vs. V_{DD} (TIMER1 AS SYSTEM CLOCK)

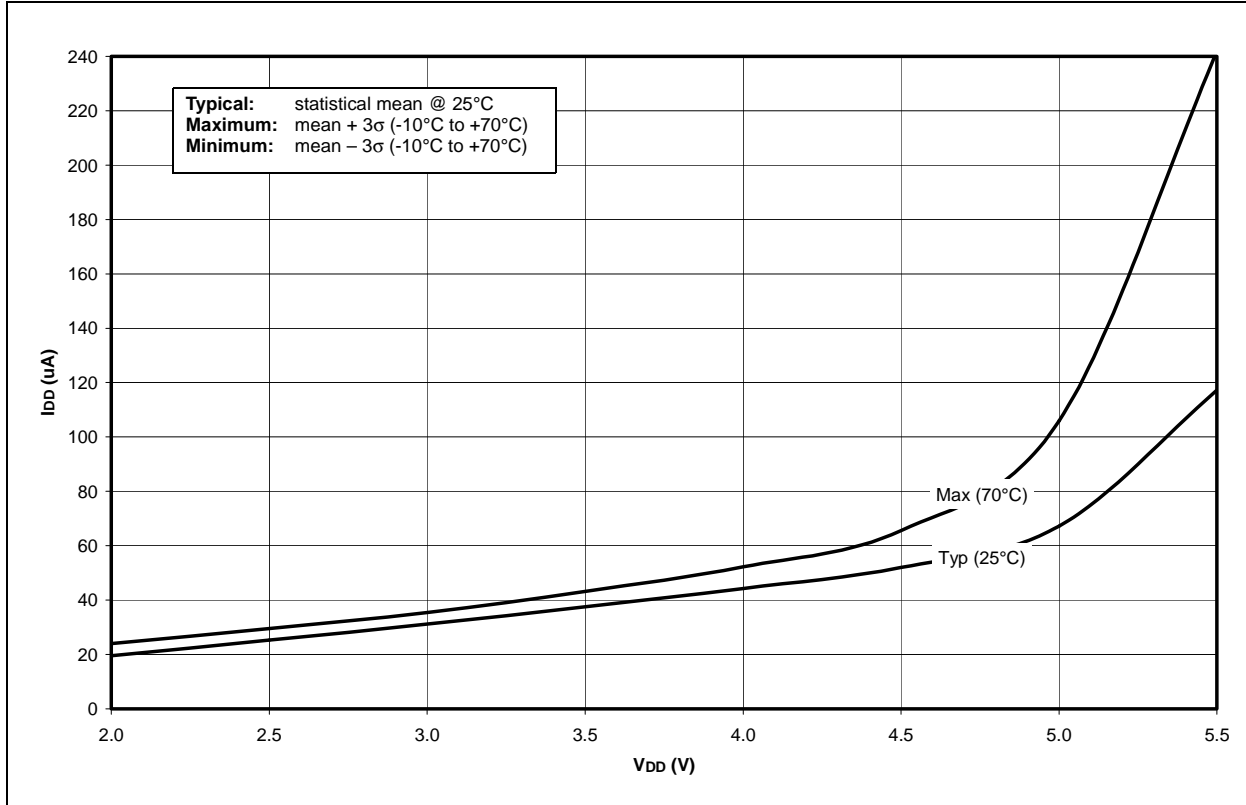
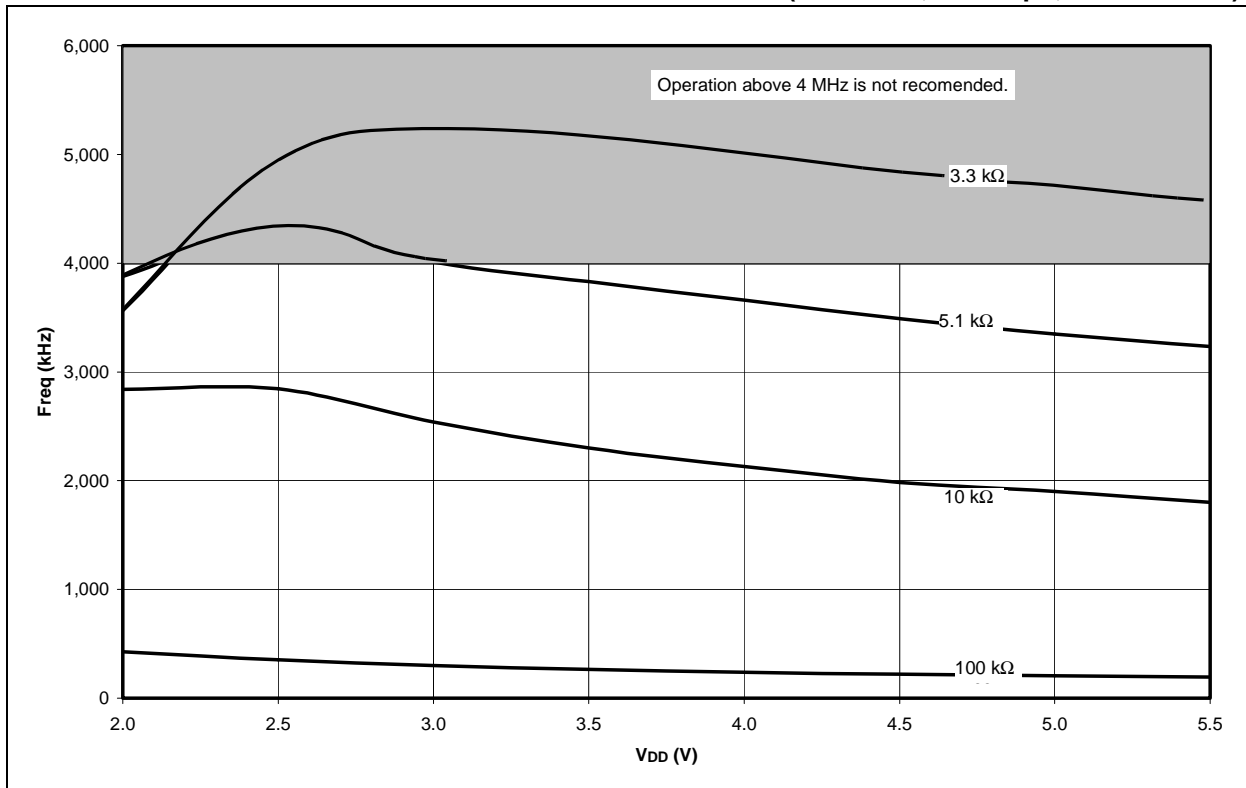

FIGURE 28-12: AVERAGE F_{OSC} vs. V_{DD} FOR VARIOUS R_s (RC MODE, $C = 20$ pF, TEMP = 25°C)



PIC18F6525/6621/8525/8621

FIGURE 28-13: AVERAGE F_{osc} vs. V_{DD} FOR VARIOUS R_s (RC MODE, $C = 100$ pF, TEMP = 25°C)

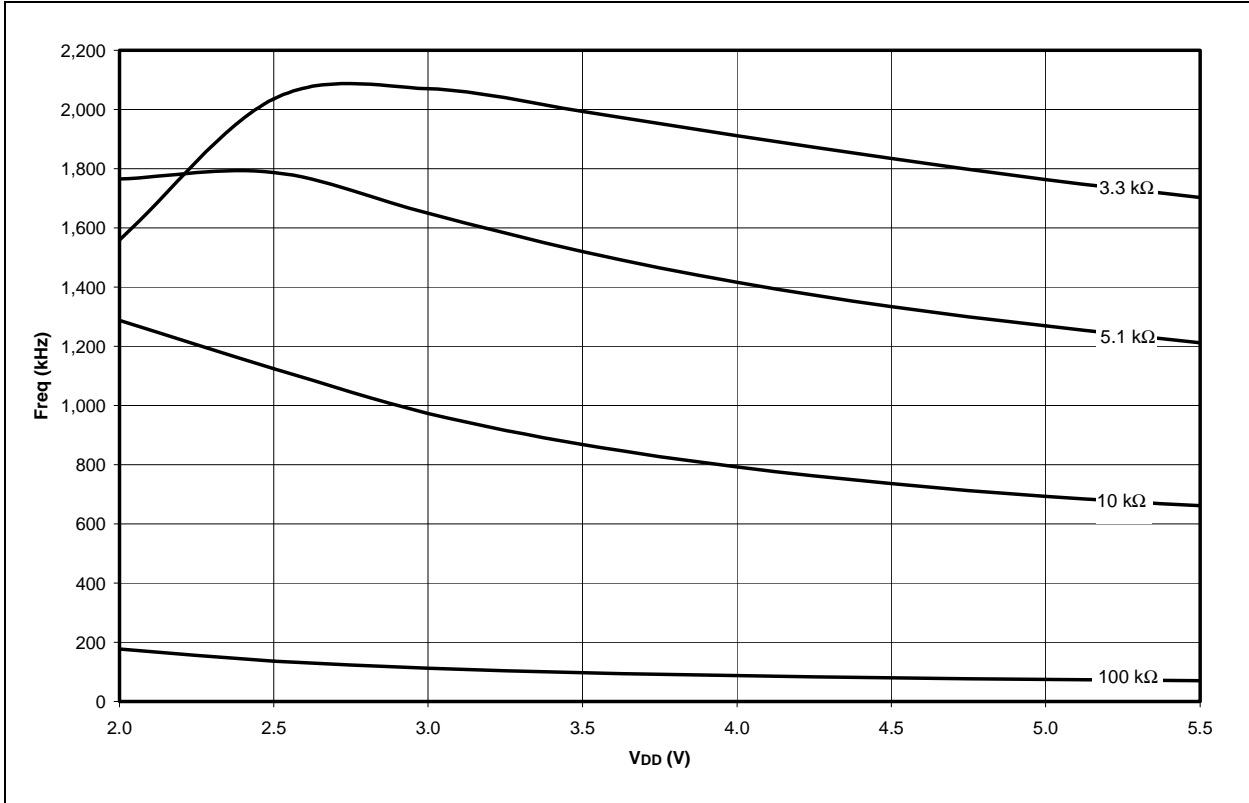
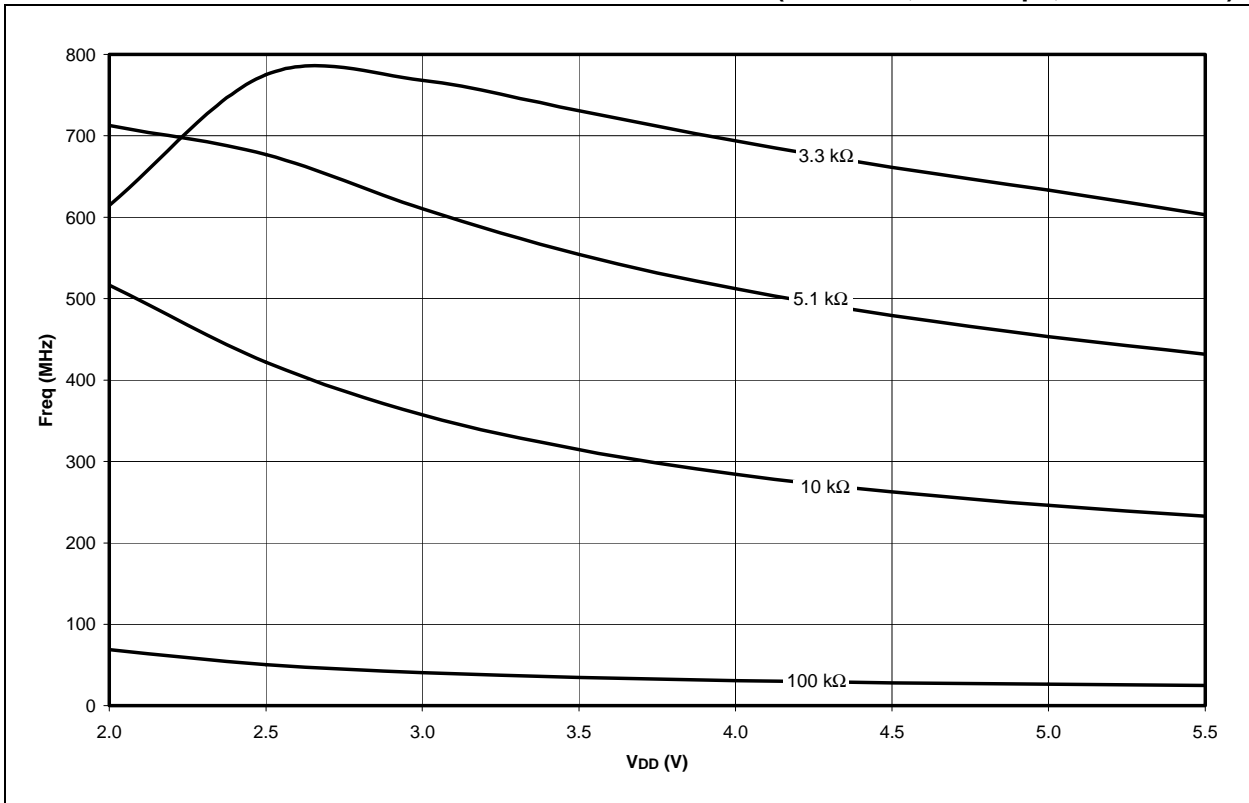

FIGURE 28-14: AVERAGE F_{osc} vs. V_{DD} FOR VARIOUS R_s (RC MODE, $C = 300$ pF, TEMP = 25°C)



PIC18F6525/6621/8525/8621

FIGURE 28-15: I_{PD} vs. V_{DD} (SLEEP MODE, ALL PERIPHERALS DISABLED)

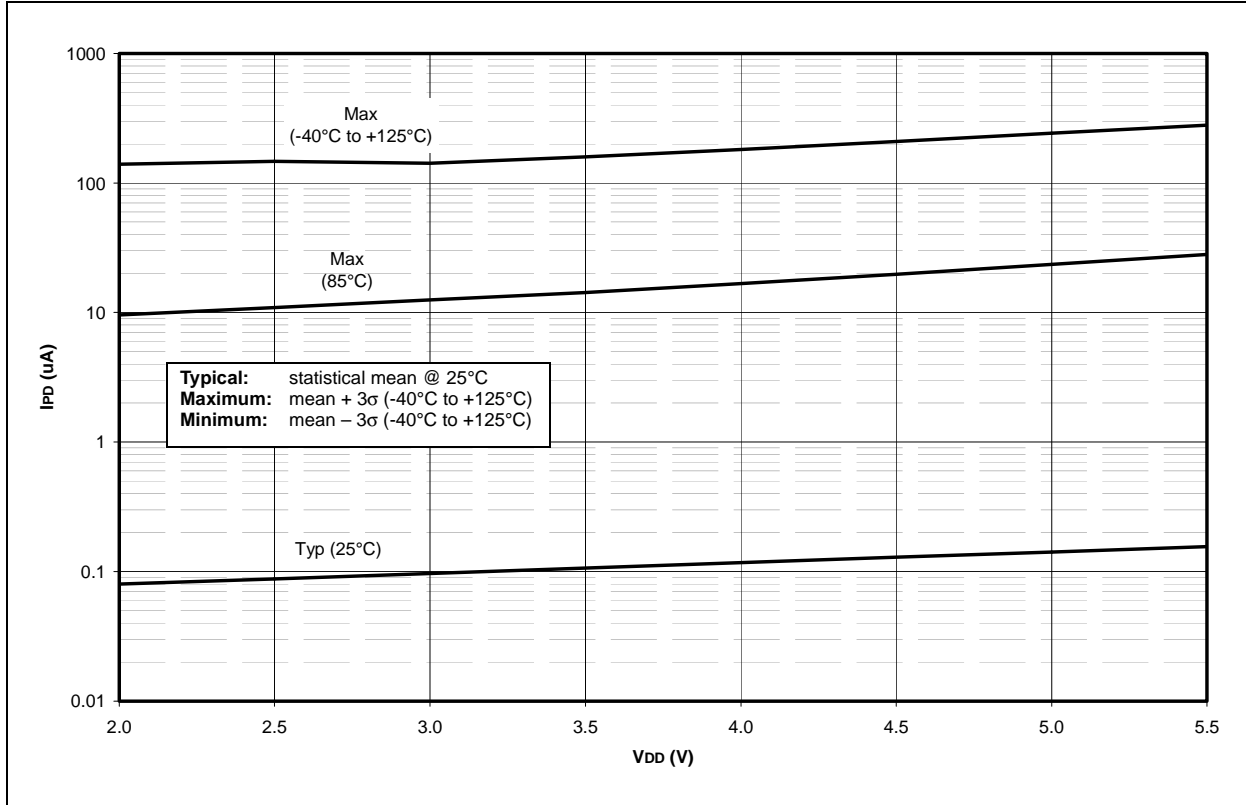
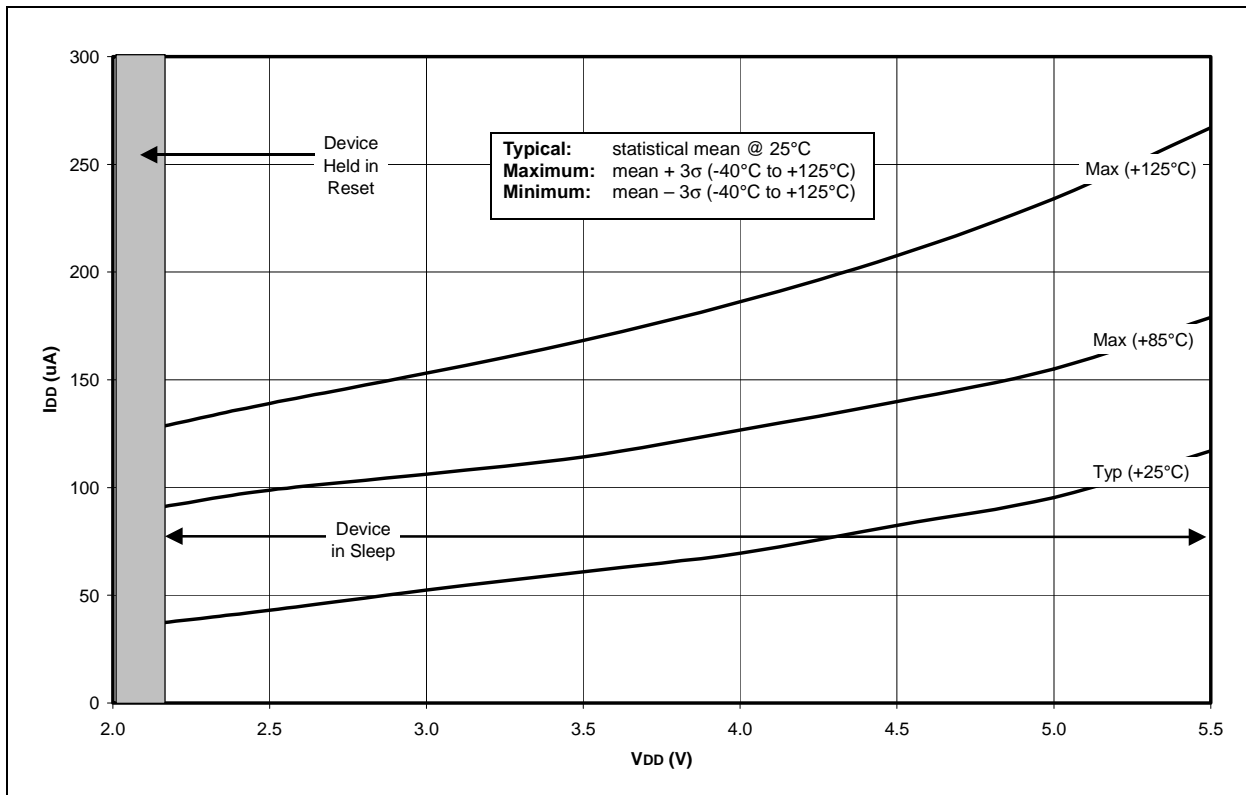

FIGURE 28-16: TYPICAL AND MAXIMUM ΔI_{BOR} vs. V_{DD} OVER TEMPERATURE, V_{BOR} = 2.00-2.16V



PIC18F6525/6621/8525/8621

FIGURE 28-17: I_{T1OSC} vs. V_{DD} (SLEEP MODE, TIMER1 AND OSCILLATOR ENABLED)

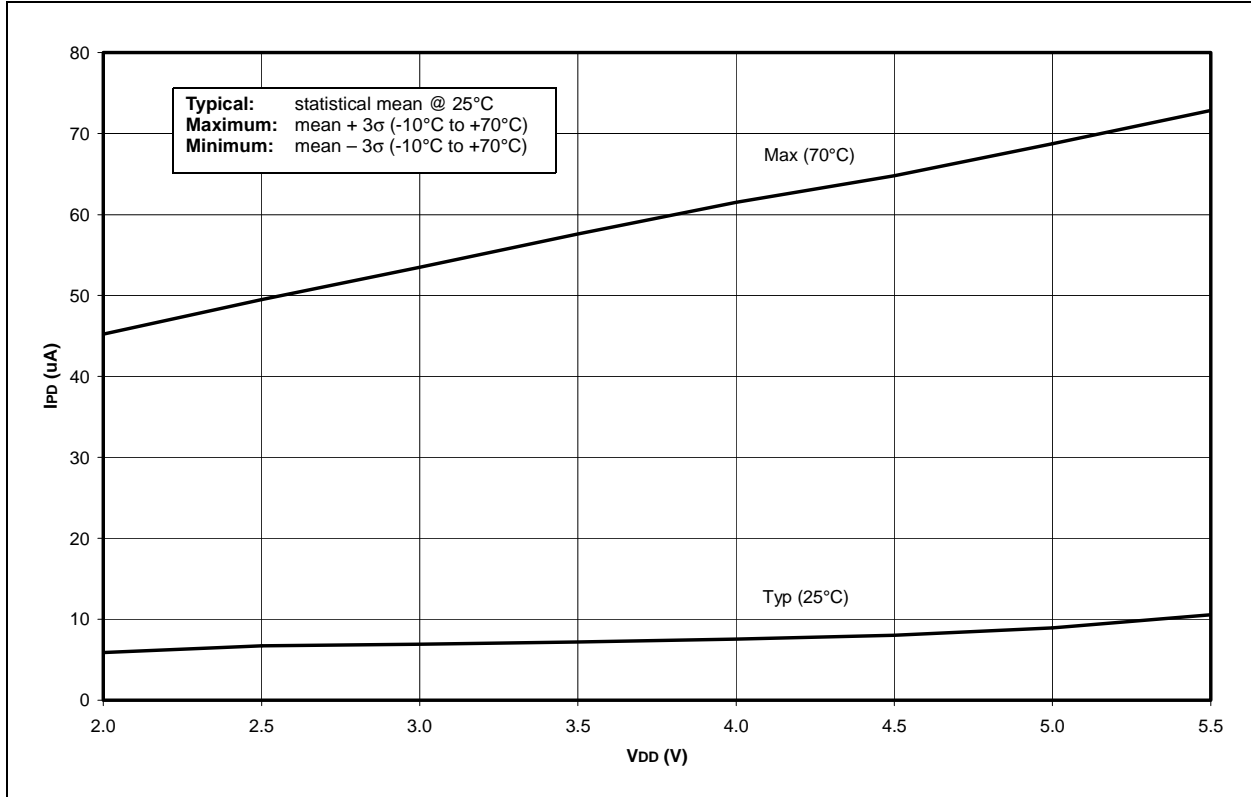
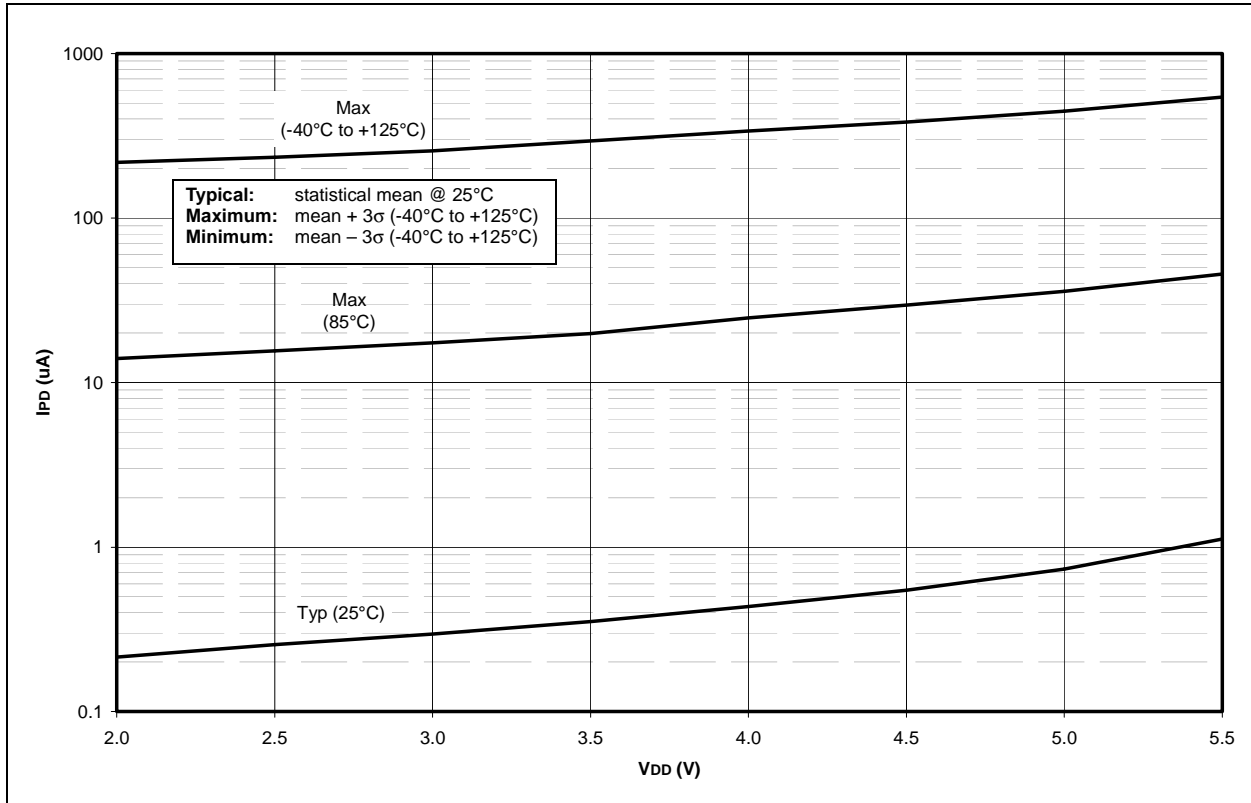

FIGURE 28-18: I_{PD} vs. V_{DD} (SLEEP MODE, WDT ENABLED)



PIC18F6525/6621/8525/8621

FIGURE 28-19: TYPICAL, MINIMUM AND MAXIMUM WDT PERIOD vs. VDD

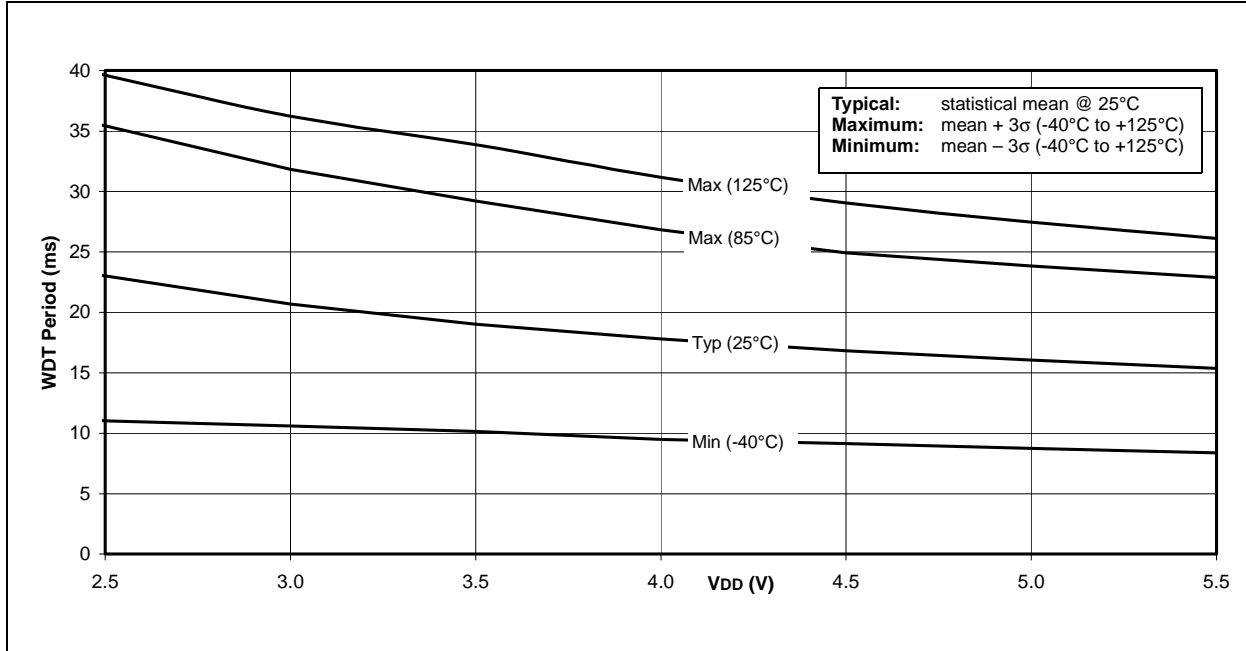
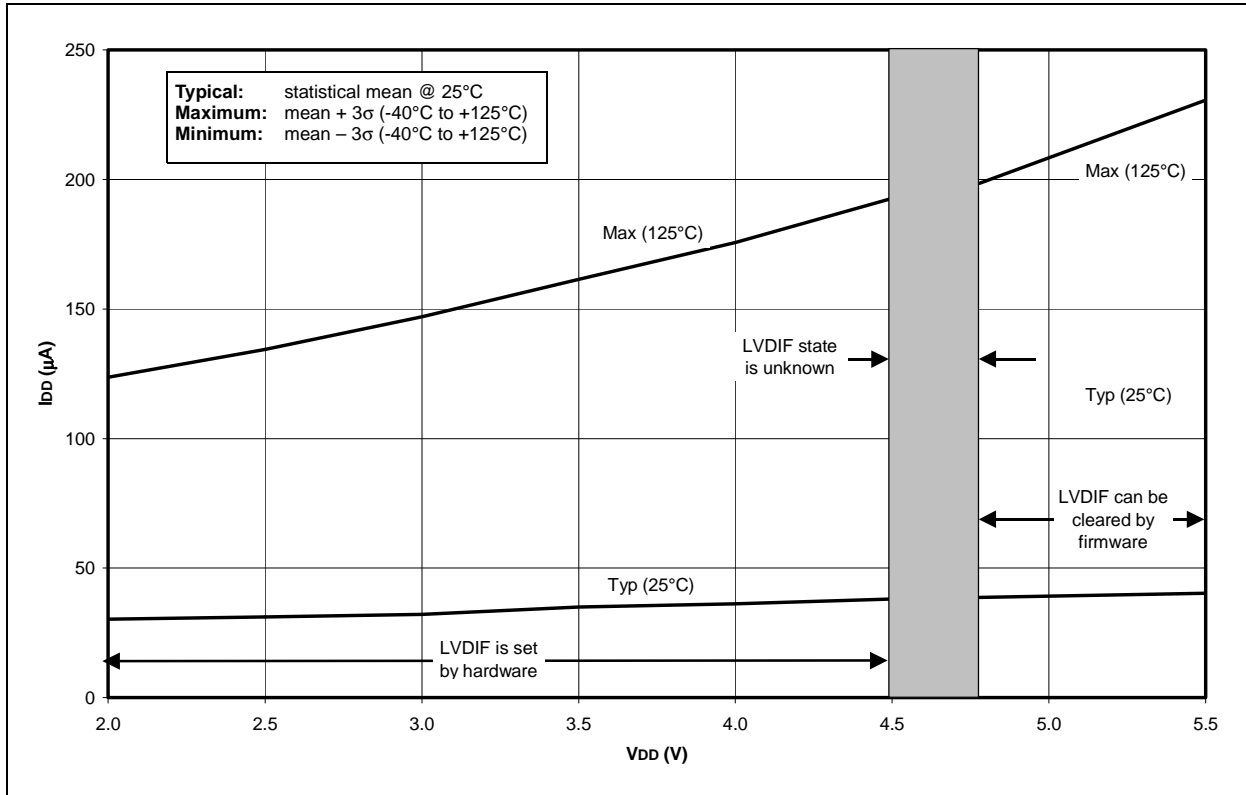

FIGURE 28-20: ΔI_{LVD} vs. VDD OVER TEMPERATURE, VLVD = 4.5-4.78V



PIC18F6525/6621/8525/8621

FIGURE 28-21: TYPICAL, MINIMUM AND MAXIMUM V_{OH} vs. I_{OH} ($V_{DD} = 5V$, $-40^{\circ}C$ TO $+125^{\circ}C$)

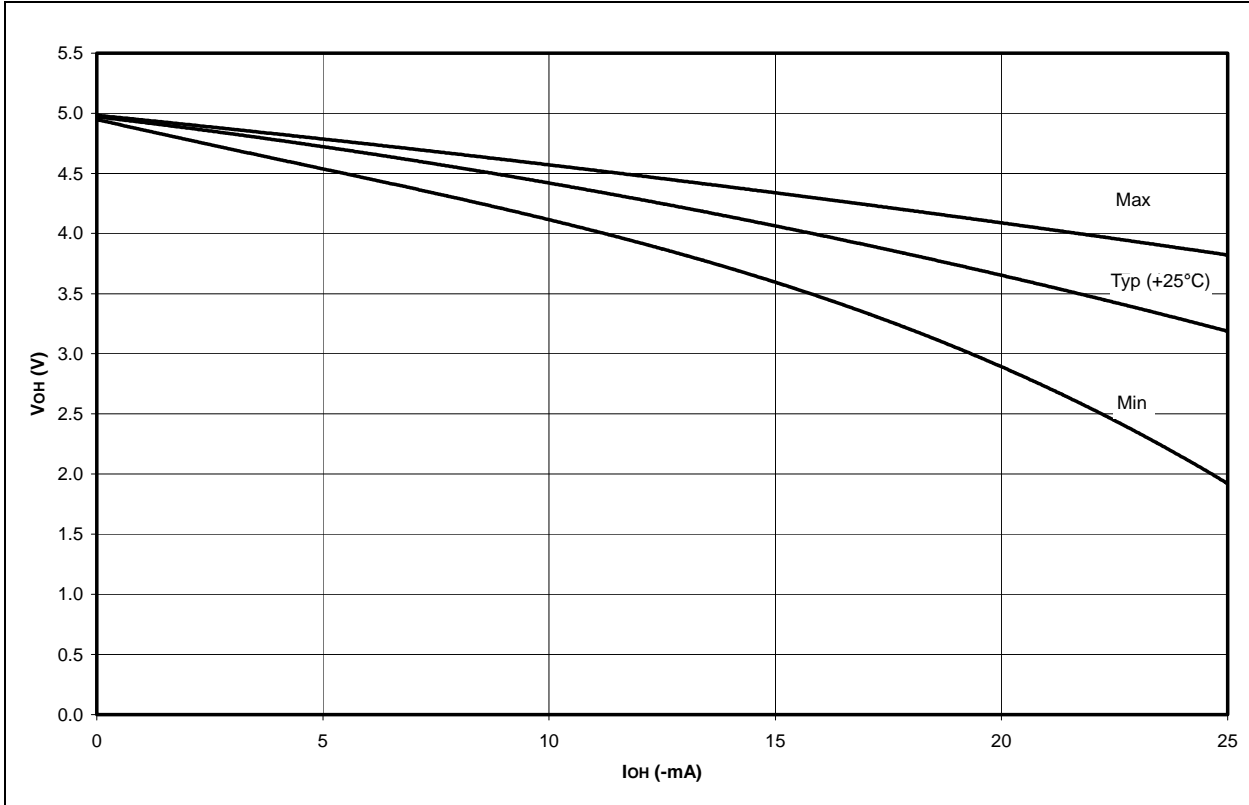
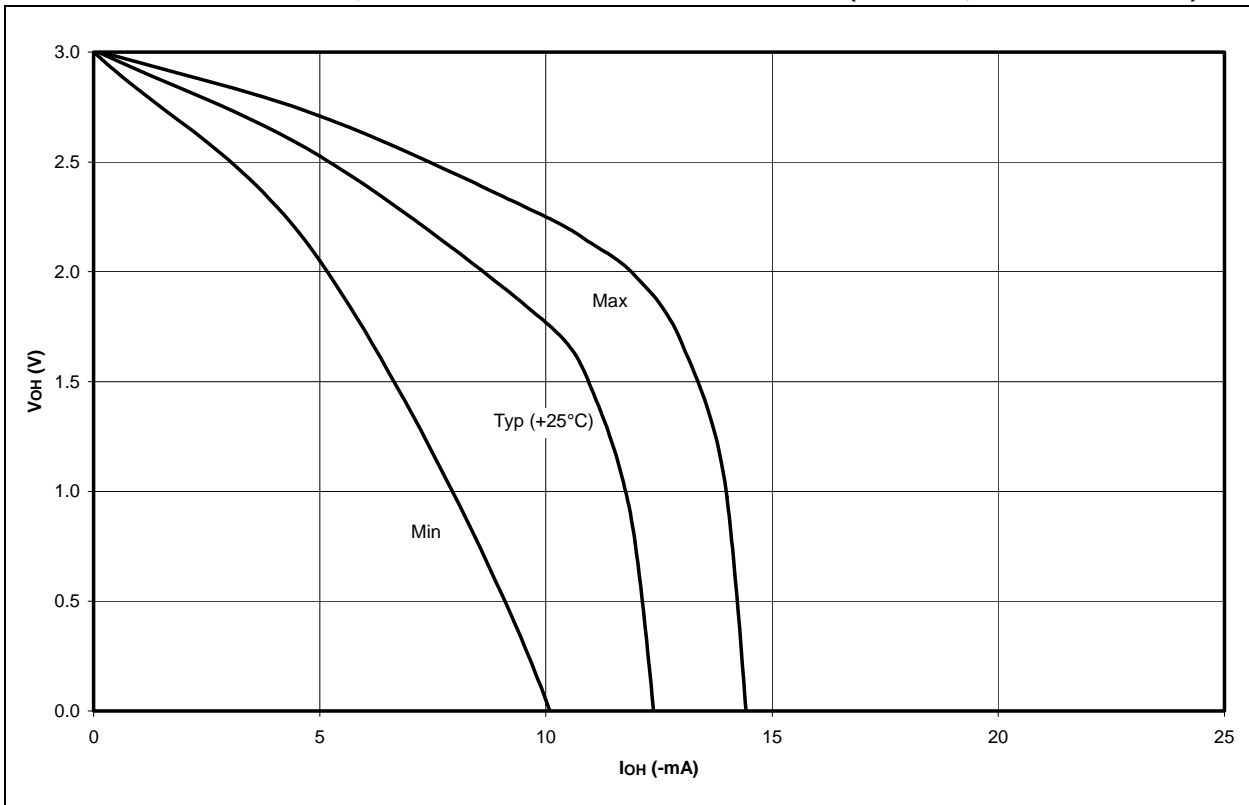

FIGURE 28-22: TYPICAL, MINIMUM AND MAXIMUM V_{OH} vs. I_{OH} ($V_{DD} = 3V$, $-40^{\circ}C$ TO $+125^{\circ}C$)



PIC18F6525/6621/8525/8621

FIGURE 28-23: TYPICAL AND MAXIMUM V_{OL} vs. I_{OL} ($V_{DD} = 5V$, $-40^{\circ}C$ TO $+125^{\circ}C$)

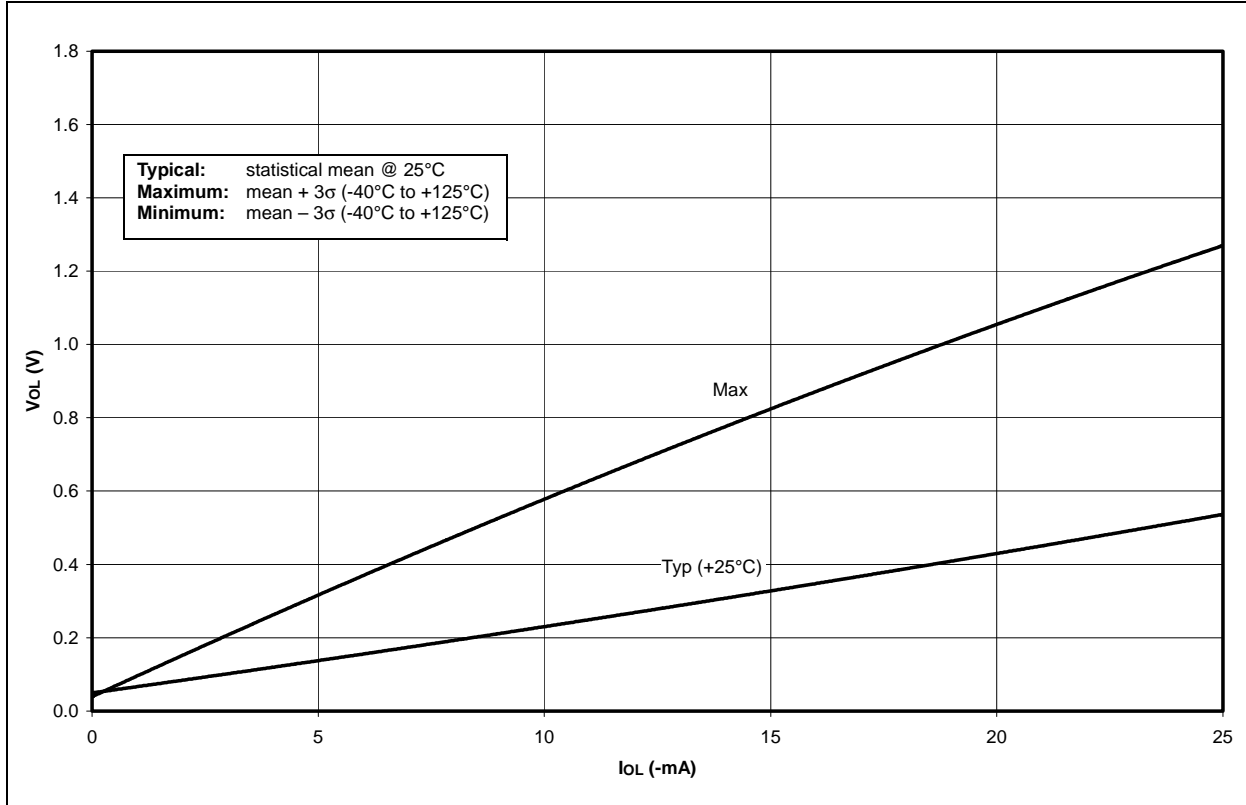
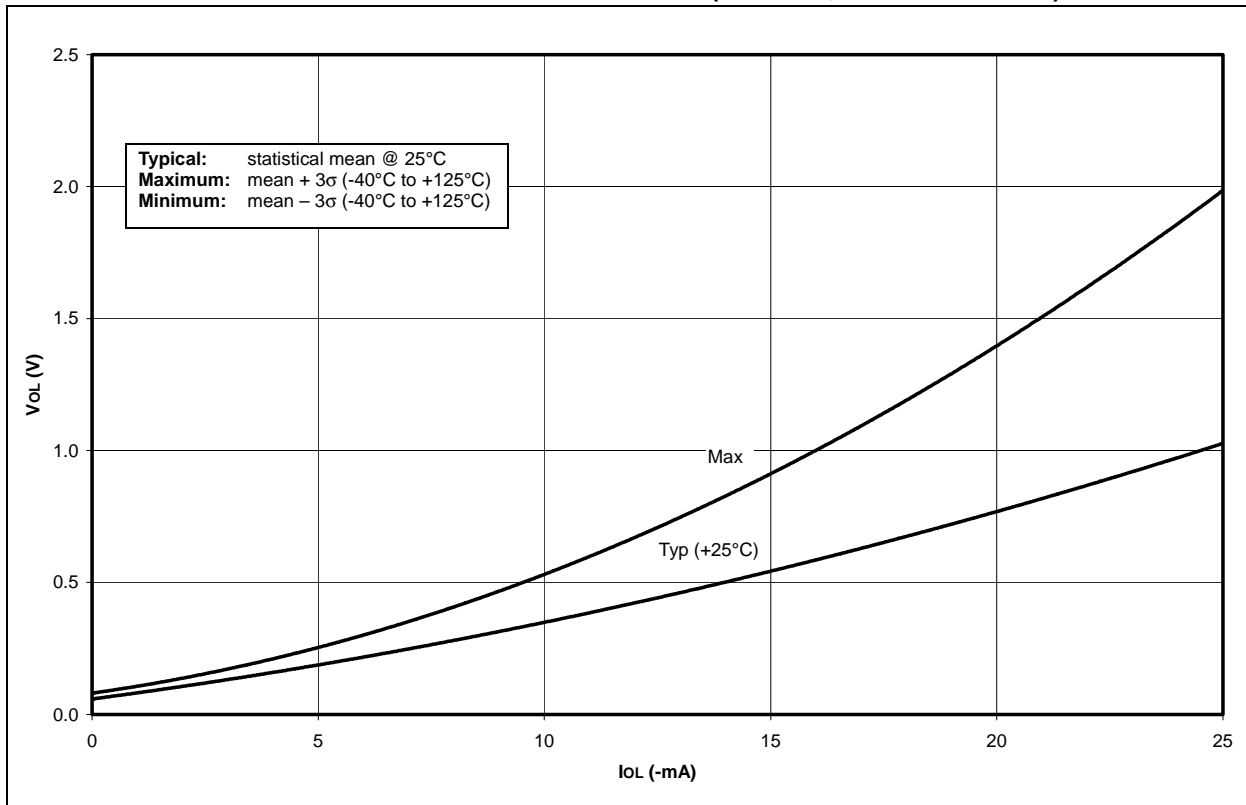

FIGURE 28-24: TYPICAL AND MAXIMUM V_{OL} vs. I_{OL} ($V_{DD} = 3V$, $-40^{\circ}C$ TO $+125^{\circ}C$)



PIC18F6525/6621/8525/8621

FIGURE 28-25: MINIMUM AND MAXIMUM V_{IN} vs. V_{DD} (ST INPUT, -40°C TO $+125^{\circ}\text{C}$)

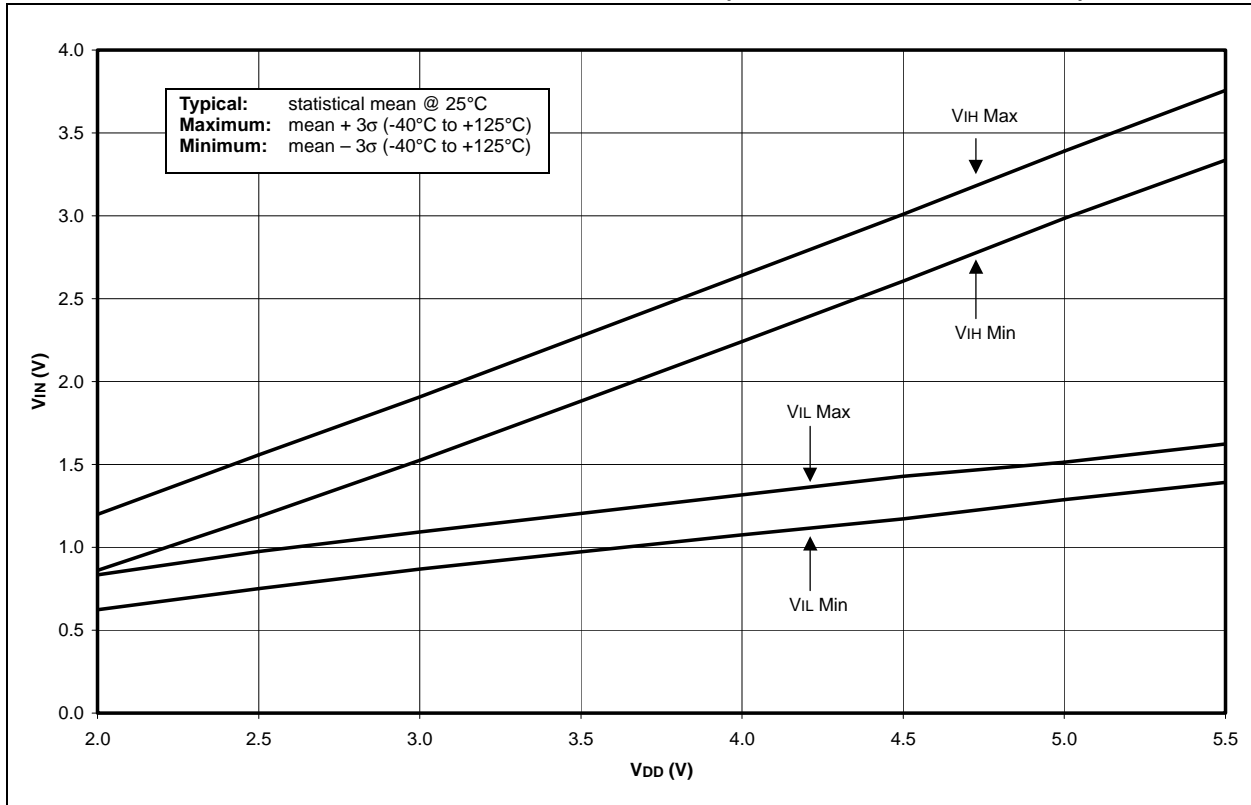
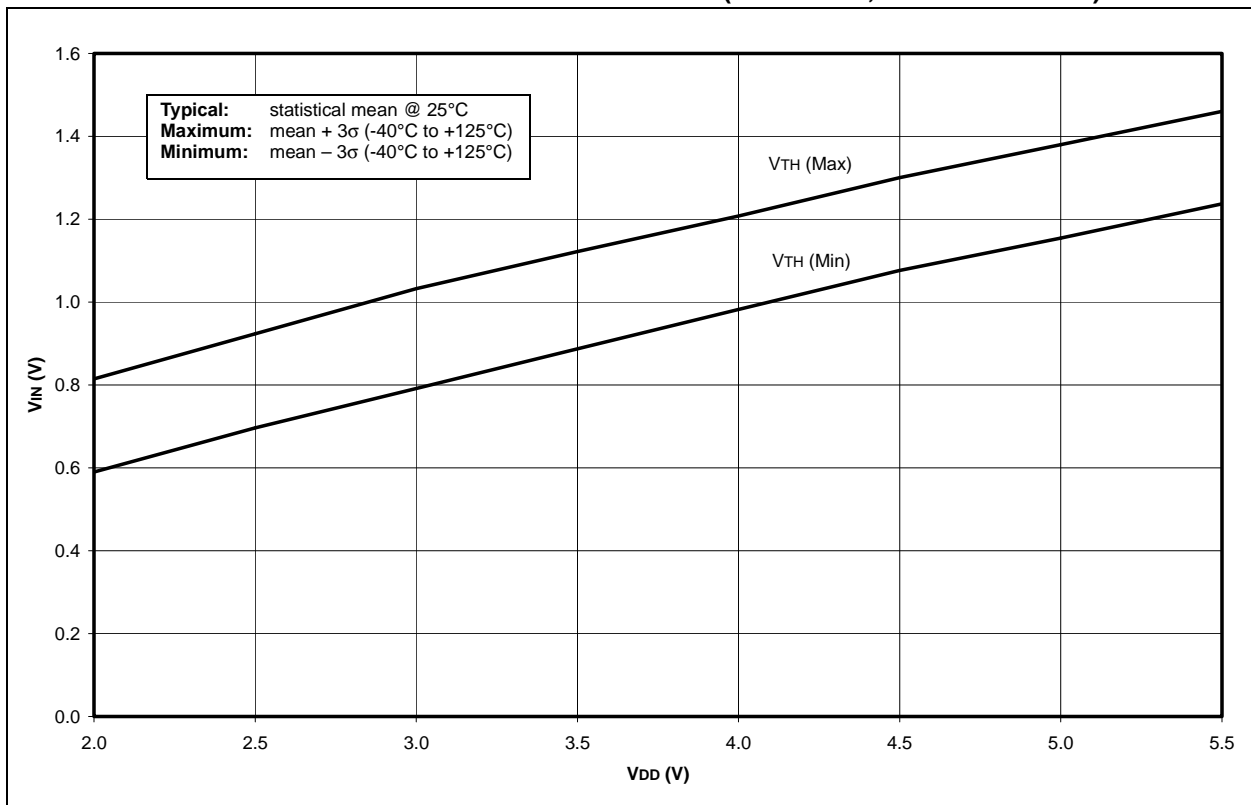

FIGURE 28-26: MINIMUM AND MAXIMUM V_{IN} vs. V_{DD} (TTL INPUT, -40°C TO $+125^{\circ}\text{C}$)



PIC18F6525/6621/8525/8621

FIGURE 28-27: MINIMUM AND MAXIMUM V_{IN} vs. V_{DD} (I^2C INPUT, $-40^{\circ}C$ TO $+125^{\circ}C$)

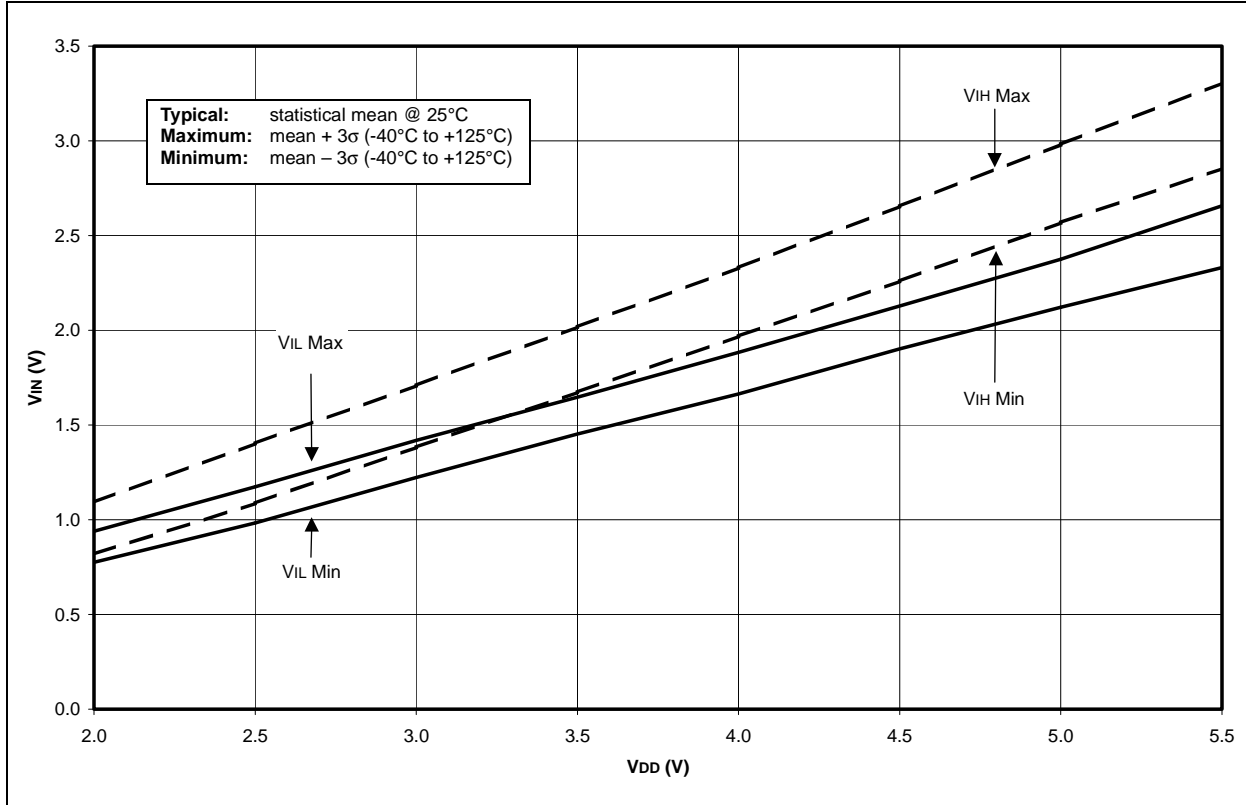
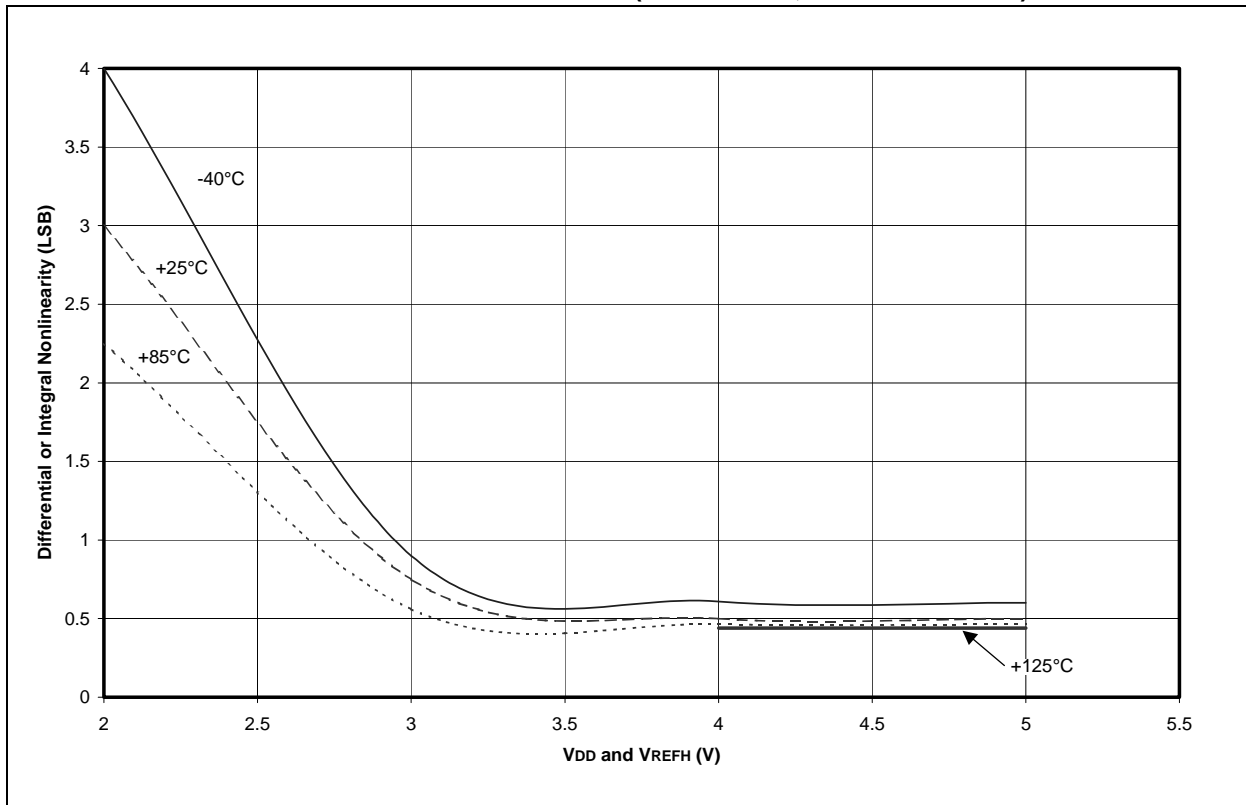
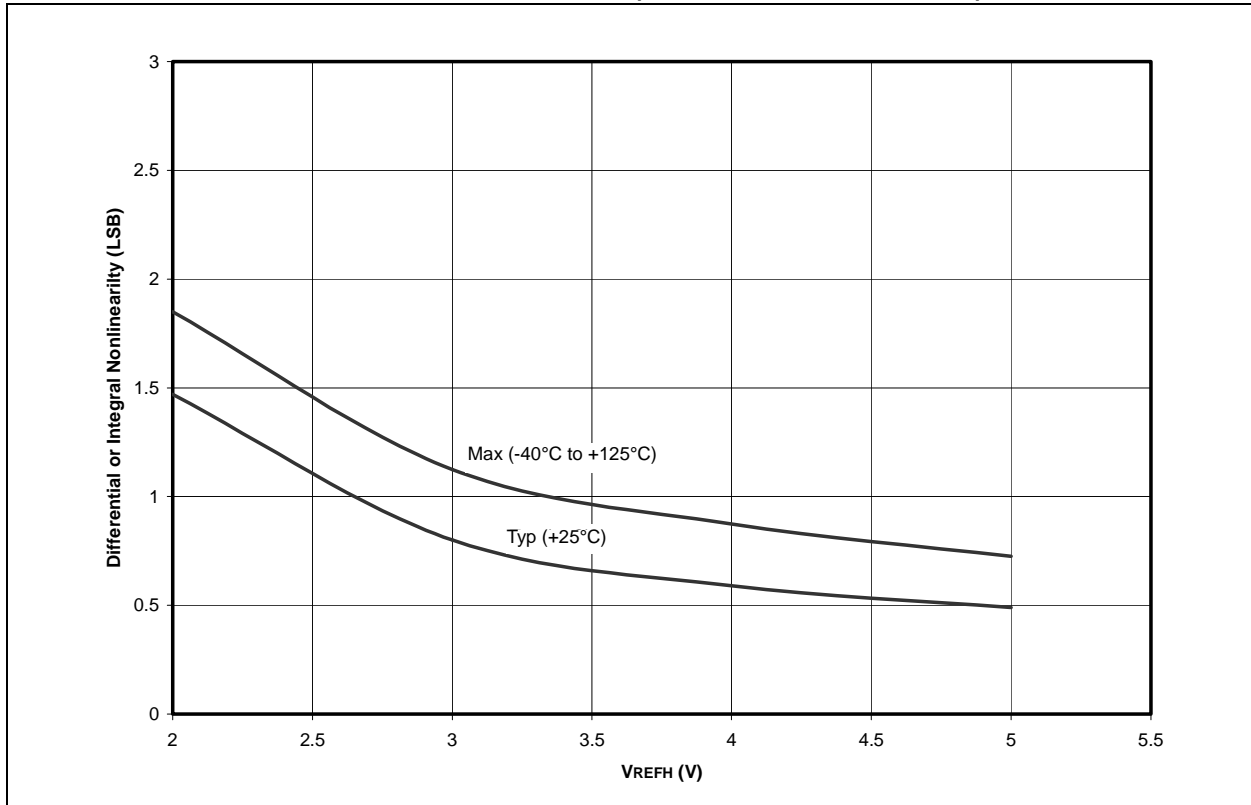

FIGURE 28-28: A/D NONLINEARITY vs. V_{REFH} ($V_{DD} = V_{REFH}$, $-40^{\circ}C$ TO $+125^{\circ}C$)



PIC18F6525/6621/8525/8621

FIGURE 28-29: A/D NONLINEARITY vs. VREFH (V_{DD} = 5V, -40°C TO +125°C)



PIC18F6525/6621/8525/8621

NOTES:

PIC18F6525/6621/8525/8621

29.0 PACKAGING INFORMATION

29.1 Package Marking Information

64-Lead TQFP

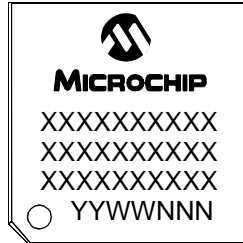

Example

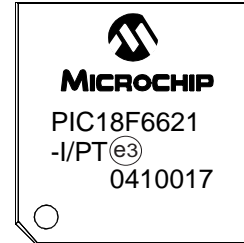

80-Lead TQFP

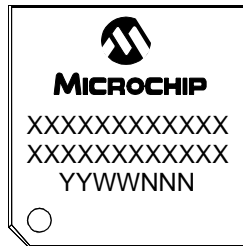

Example

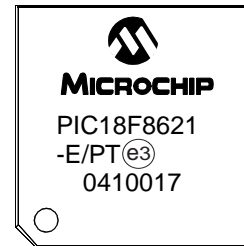

Legend:	XX...X	Customer-specific information
	Y	Year code (last digit of calendar year)
	YY	Year code (last 2 digits of calendar year)
	WW	Week code (week of January 1 is week '01')
	NNN	Alphanumeric traceability code
	^(e3)	Pb-free JEDEC designator for Matte Tin (Sn)
	*	This package is Pb-free. The Pb-free JEDEC designator (^(e3)) can be found on the outer packaging for this package.

Note: In the event the full Microchip part number cannot be marked on one line, it will be carried over to the next line, thus limiting the number of available characters for customer-specific information.

PIC18F6525/6621/8525/8621

29.2 Package Details

The following sections give the technical details of the packages.

64-Lead Plastic Thin Quad Flatpack (PT) 10x10x1 mm Body, 1.0/0.10 mm Lead Form (TQFP)

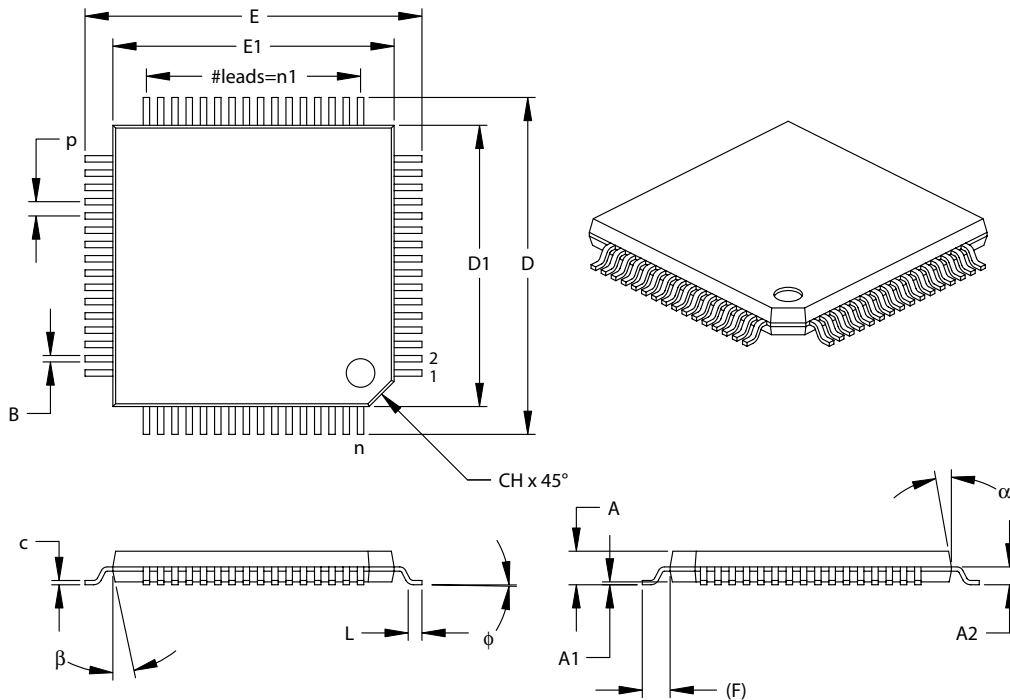

Units		INCHES			MILLIMETERS*		
Dimension Limits		MIN	NOM	MAX	MIN	NOM	MAX
Number of Pins	n	64			64		
Pitch	p		.020			0.50	
Pins per Side	n1		16			16	
Overall Height	A	.039	.043	.047	1.00	1.10	1.20
Molded Package Thickness	A2	.037	.039	.041	0.95	1.00	1.05
Standoff	A1	.002	.006	.010	0.05	0.15	0.25
Foot Length	L	.018	.024	.030	0.45	0.60	0.75
Footprint (Reference)	(F)		.039			1.00	
Foot Angle	φ	0	3.5	7	0	3.5	7
Overall Width	E	.463	.472	.482	11.75	12.00	12.25
Overall Length	D	.463	.472	.482	11.75	12.00	12.25
Molded Package Width	E1	.390	.394	.398	9.90	10.00	10.10
Molded Package Length	D1	.390	.394	.398	9.90	10.00	10.10
Lead Thickness	c	.005	.007	.009	0.13	0.18	0.23
Lead Width	B	.007	.009	.011	0.17	0.22	0.27
Pin 1 Corner Chamfer	CH	.025	.035	.045	0.64	0.89	1.14
Mold Draft Angle Top	α	5	10	15	5	10	15
Mold Draft Angle Bottom	β	5	10	15	5	10	15

*Controlling Parameter

Notes:

Dimensions D1 and E1 do not include mold flash or protrusions. Mold flash or protrusions shall not exceed .010" (0.254mm) per side.

JEDEC Equivalent: MS-026

Drawing No. C04-085

PIC18F6525/6621/8525/8621

80-Lead Plastic Thin Quad Flatpack (PT) 12x12x1 mm Body, 1.0/0.10 mm Lead Form (TQFP)

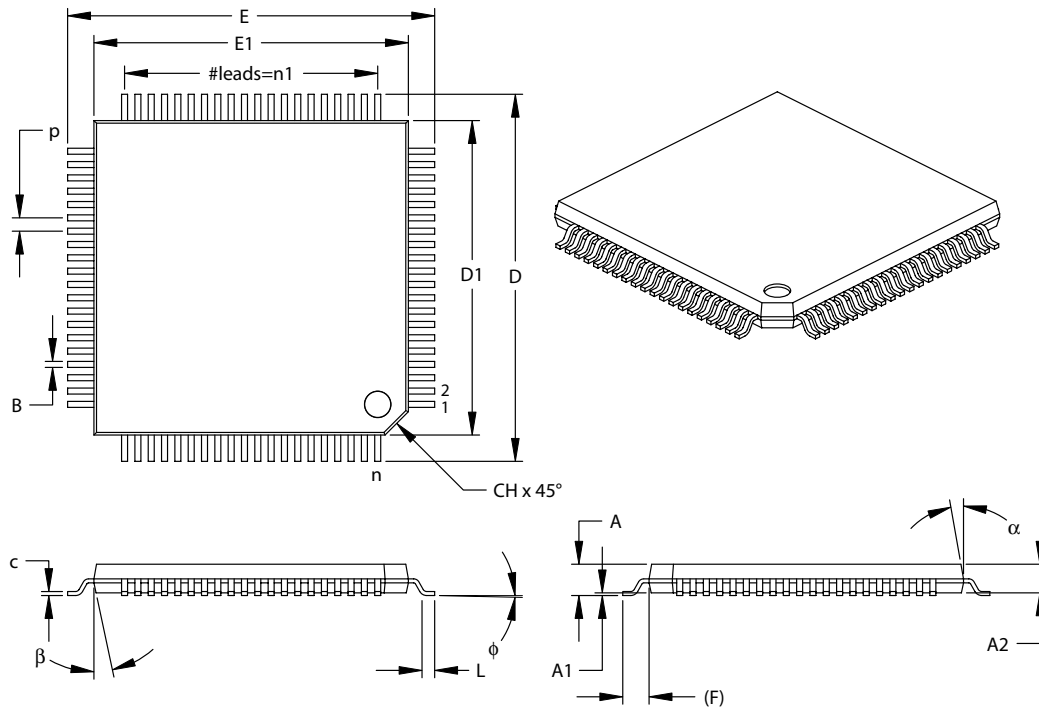

Units		INCHES			MILLIMETERS*		
Dimension Limits		MIN	NOM	MAX	MIN	NOM	MAX
Number of Pins	n	80			80		
Pitch	P		.020			0.50	
Pins per Side	n1		20			20	
Overall Height	A	.039	.043	.047	1.00	1.10	1.20
Molded Package Thickness	A2	.037	.039	.041	0.95	1.00	1.05
Standoff	A1	.002	.004	.006	0.05	0.10	0.15
Foot Length	L	.018	.024	.030	0.45	0.60	0.75
Footprint (Reference)	(F)		.039			1.00	
Foot Angle	φ	0	3.5	7	0	3.5	7
Overall Width	E	.541	.551	.561	13.75	14.00	14.25
Overall Length	D	.541	.551	.561	13.75	14.00	14.25
Molded Package Width	E1	.463	.472	.482	11.75	12.00	12.25
Molded Package Length	D1	.463	.472	.482	11.75	12.00	12.25
Lead Thickness	c	.004	.006	.008	0.09	0.15	0.20
Lead Width	B	.007	.009	.011	0.17	0.22	0.27
Pin 1 Corner Chamfer	CH	.025	.035	.045	0.64	0.89	1.14
Mold Draft Angle Top	α	5	10	15	5	10	15
Mold Draft Angle Bottom	β	5	10	15	5	10	15

*Controlling Parameter

Notes:

Dimensions D1 and E1 do not include mold flash or protrusions. Mold flash or protrusions shall not exceed .010" (0.254mm) per side.

JEDEC Equivalent: MS-026

Drawing No. C04-092

PIC18F6525/6621/8525/8621

NOTES:

PIC18F6525/6621/8525/8621

APPENDIX A: REVISION HISTORY

Revision A (July 2003)

Original data sheet for PIC18F6525/6621/8525/8621 family.

Revision B (August 2004)

This revision includes updates to the Electrical Specifications in **Section 27.0**, the DC and AC Characteristics Graphs and Tables in **Section 28.0** have been added and includes minor corrections to the data sheet text.

APPENDIX B: DEVICE DIFFERENCES

The differences between the devices listed in this data sheet are shown in Table B-1.

TABLE B-1: DEVICE DIFFERENCES

Feature	PIC18F6525	PIC18F6621	PIC18F8525	PIC18F8621
On-chip Program Memory (Kbytes)	48K	64K	48K	64K
I/O Ports	Ports A, B, C, D, E, F, G	Ports A, B, C, D, E, F, G	Ports A, B, C, D, E, F, G, H, J	Ports A, B, C, D, E, F, G, H, J
A/D Channels	12	12	16	16
External Memory Interface	No	No	Yes	Yes
Package Types	64-pin TQFP	64-pin TQFP	80-pin TQFP	80-pin TQFP

PIC18F6525/6621/8525/8621

APPENDIX C: CONVERSION CONSIDERATIONS

This appendix discusses the considerations for converting from previous versions of a device to the ones listed in this data sheet. Typically, these changes are due to the differences in the process technology used. An example of this type of conversion is from a PIC17C756 to a PIC18F8720.

Not Applicable

APPENDIX D: MIGRATION FROM MID-RANGE TO ENHANCED DEVICES

A detailed discussion of the differences between the mid-range MCU devices (i.e., PIC16CXXX) and the enhanced devices (i.e., PIC18FXXX) is provided in AN716, *"Migrating Designs from PIC16C74A/74B to PIC18C442."* The changes discussed, while device specific, are generally applicable to all mid-range to enhanced device migrations.

This Application Note is available as Literature Number DS00716.

APPENDIX E: MIGRATION FROM HIGH-END TO ENHANCED DEVICES

A detailed discussion of the migration pathway and differences between the high-end MCU devices (i.e., PIC17CXXX) and the enhanced devices (i.e., PIC18FXXX) is provided in AN726, "*PIC17CXXX to PIC18CXXX Migration*."

This Application Note is available as Literature Number DS00726.

PIC18F6525/6621/8525/8621

NOTES:

PIC18F6525/6621/8525/8621

INDEX

A

A/D	233
Acquisition Requirements	238
Acquisition Time	238
ADCON0 Register	233
ADCON1 Register	233
ADCON2 Register	233
ADRESH Register	233, 236
ADRESL Register	233, 236
Analog Port Pins	128
Analog Port Pins, Configuring	240
Associated Register Summary	241
Automatic Acquisition Time	239
Calculating Minimum Required	
Acquisition Time	238
Configuring the Module	237
Conversion Clock (TAD)	239
Conversion Status (GO/DONE Bit)	236
Conversion TAD Cycles	240
Conversions	240
Converter Characteristics	354
Converter Interrupt, Configuring	237
ECCP2 Special Event Trigger	241
Equations	238
Minimum Charging Time	238
Selecting and Configuring	
Acquisition Time	239
Special Event Trigger (ECCP)	160
TAD vs. Device Operating	
Frequencies (table)	239
Absolute Maximum Ratings	323
AC (Timing) Characteristics	335
Load Conditions for Device	
Timing Specifications	336
Parameter Symbolology	335
Temperature and Voltage	
Specifications	336
Timing Conditions	336
ACKSTAT	203
ACKSTAT Status Flag	203
ADCON0 Register	233
GO/DONE Bit	236
ADCON1 Register	233
ADCON2 Register	233
ADDLW	281
ADDWF	281
ADDWFC	282
ADRESH Register	233, 236
ADRESL Register	233, 236
Analog-to-Digital Converter. See A/D.	
ANDLW	282
ANDWF	283
Assembler	
MPASM Assembler	317
Auto-Wake-up on Sync Break Character	225
B	
Baud Rate Generator	199
BC	283
BCF	284
BF	203
BF Status Flag	203

Block Diagrams

16-Bit Byte Select Mode	75
16-Bit Byte Write Mode	73
16-Bit Word Write Mode	74
A/D	236
Analog Input Model	237
Baud Rate Generator	199
Capture Mode Operation	151
Comparator Analog Input Model	247
Comparator I/O Operating Modes	244
Comparator Output	246
Comparator Voltage Reference	250
Comparator Voltage Reference	
Output Buffer Example	251
Compare Mode Operation	152
Enhanced PWM	161
EUSART Receive	223
EUSART Transmit	221
Low-Voltage Detect (LVD)	254
Low-Voltage Detect with External Input	254
MCLR/VPP/RG5 Pin	121
MSSP (I ² C Master Mode)	197
MSSP (I ² C Mode)	182
MSSP (SPI Mode)	173
On-Chip Reset Circuit	29
PIC18F6525/6621	9
PIC18F8525/8621	10
PLL	23
Port/LAT/TRIS Operation	103
PORTC (Peripheral Output Override)	109
PORTD and PORTE (Parallel Slave Port)	128
PORTD in I/O Port Mode	111
PORTD in System Bus Mode	112
PORTE in I/O Mode	115
PORTE in System Bus Mode	115
PORTG (Peripheral Output Override)	120
PORTJ in I/O Mode	125
PWM Operation (Simplified)	154
RA3:RA0 and RA5 Pins	104
RA4/T0CKI Pin	104
RA6 Pin (Enabled as I/O)	104
RB2:RB0 Pins	107
RB3 Pin	107
RB7:RB4 Pins	106
Reads from Flash Program Memory	65
RF1/AN6/C2OUT and RF2/AN7/C1OUT Pins	117
RF6:RF3 and RF0 Pins	118
RF7 Pin	118
RH3:RH0 Pins in I/O Mode	122
RH3:RH0 Pins in System Bus Mode	123
RH7:RH4 Pins in I/O Mode	122
RJ4:RJ0 Pins in System Bus Mode	126
RJ7:RJ6 Pins in System Bus Mode	126
Single Comparator	245
Table Read Operation	61
Table Write Operation	62
Table Writes to Flash Program Memory	67
Timer0 in 16-Bit Mode	132
Timer0 in 8-Bit Mode	132
Timer1	136
Timer1 (16-Bit Read/Write Mode)	136
Timer2	142

PIC18F6525/6621/8525/8621

Timer3.....	144	Initializing PORTE.....	114
Timer3 (16-Bit Read/Write Mode).....	144	Initializing PORTF.....	117
Timer4.....	148	Initializing PORTG.....	120
Watchdog Timer.....	268	Initializing PORTH.....	122
BN.....	284	Initializing PORTJ.....	125
BNC.....	285	Loading the SSPBUF (SSPSR) Register.....	176
BNN.....	285	Reading a Flash Program Memory Word.....	65
BNOV.....	286	Saving STATUS, WREG and	
BNZ.....	286	BSR Registers in RAM.....	102
BOR. See Brown-out Reset.		Writing to Flash Program Memory.....	68–69
BOV.....	289	Code Protection.....	259, 270
BRA.....	287	Associated Registers.....	271
Break Character (12-Bit) Transmit and Receive.....	226	Configuration Register Protection.....	273
BRG. See Baud Rate Generator.		Data EEPROM.....	273
Brown-out Reset (BOR).....	30, 259	Program Memory.....	271
BSF.....	287	COMF.....	292
BTFSC.....	288	Comparator.....	243
BTFSS.....	288	Analog Input Connection Considerations.....	247
BTG.....	289	Associated Registers.....	248
BZ.....	290	Configuration.....	244
C		Effects of a Reset.....	247
C Compilers		Interrupts.....	246
MPLAB C17.....	318	Operation.....	245
MPLAB C18.....	318	Operation During Sleep.....	247
MPLAB C30.....	318	Outputs.....	245
CALL.....	290	Reference.....	245
Capture (CCP Module).....	151	External Signal.....	245
Associated Registers.....	153	Internal Signal.....	245
CCP Pin Configuration.....	151	Response Time.....	245
CCPR4H:CCPR4L Registers.....	151	Comparator Specifications.....	332
Software Interrupt.....	151	Comparator Voltage Reference.....	249
Timer1/Timer3 Mode Selection.....	151	Accuracy and Error.....	250
Capture (ECCP Module).....	160	Associated Registers.....	251
Capture/Compare/PWM (CCP).....	149	Configuring.....	249
Capture Mode. See Capture.		Connection Considerations.....	250
CCP Mode and Timer Resources.....	150	Effects of a Reset.....	250
CCPRxH Register.....	150	Operation During Sleep.....	250
CCPRxL Register.....	150	Compare (CCP Module).....	152
Compare Mode. See Compare.		Associated Registers.....	153
Interconnect Configurations.....	150	CCP Pin Configuration.....	152
Module Configuration.....	150	CCPR1 Register.....	152
PWM Mode. See PWM.		Software Interrupt.....	152
Clocking Scheme/Instruction Cycle.....	44	Special Event Trigger.....	152
CLRF.....	291	Timer1/Timer3 Mode Selection.....	152
CLRWDT.....	291	Compare (ECCP Module).....	160
Code Examples		Special Event Trigger.....	137, 145, 160
16 x 16 Signed Multiply Routine.....	86	Configuration Bits.....	259
16 x 16 Unsigned Multiply Routine.....	86	Context Saving During Interrupts.....	102
8 x 8 Signed Multiply Routine.....	85	Control Registers	
8 x 8 Unsigned Multiply Routine.....	85	EECON1 and EECON2.....	62
Changing Between Capture Prescalers.....	151	TABLAT (Table Latch) Register.....	64
Computed GOTO Using an Offset Value.....	46	TBLPTR (Table Pointer) Register.....	64
Data EEPROM Read.....	81	Conversion Considerations.....	378
Data EEPROM Refresh Routine.....	82	CPFSEQ.....	292
Data EEPROM Write.....	81	CPFSGT.....	293
Erasing a Flash Program Memory Row.....	66	CPFSLT.....	293
Fast Register Stack.....	44	D	
How to Clear RAM (Bank 1) Using		Data EEPROM Memory.....	79
Indirect Addressing.....	56	Associated Registers.....	83
Implementing a Real-Time Clock Using a		EEADR Register.....	79
Timer1 Interrupt Service.....	138	EEADRH Register.....	79
Initializing PORTA.....	103	EECON1 Register.....	79
Initializing PORTB.....	106	EECON2 Register.....	79
Initializing PORTC.....	109	Operation During Code-Protect.....	82
Initializing PORTD.....	111	Protection Against Spurious Write.....	82
Initializing PORTE.....	114		
Initializing PORTF.....	117		
Initializing PORTG.....	120		
Initializing PORTH.....	122		
Initializing PORTJ.....	125		
Loading the SSPBUF (SSPSR) Register.....	176		
Reading a Flash Program Memory Word.....	65		
Saving STATUS, WREG and			
BSR Registers in RAM.....	102		
Writing to Flash Program Memory.....	68–69		
Code Protection.....	259, 270		
Associated Registers.....	271		
Configuration Register Protection.....	273		
Data EEPROM.....	273		
Program Memory.....	271		
COMF.....	292		
Comparator.....	243		
Analog Input Connection Considerations.....	247		
Associated Registers.....	248		
Configuration.....	244		
Effects of a Reset.....	247		
Interrupts.....	246		
Operation.....	245		
Operation During Sleep.....	247		
Outputs.....	245		
Reference.....	245		
External Signal.....	245		
Internal Signal.....	245		
Response Time.....	245		
Comparator Specifications.....	332		
Comparator Voltage Reference.....	249		
Accuracy and Error.....	250		
Associated Registers.....	251		
Configuring.....	249		
Connection Considerations.....	250		
Effects of a Reset.....	250		
Operation During Sleep.....	250		
Compare (CCP Module).....	152		
Associated Registers.....	153		
CCP Pin Configuration.....	152		
CCPR1 Register.....	152		
Software Interrupt.....	152		
Special Event Trigger.....	152		
Timer1/Timer3 Mode Selection.....	152		
Compare (ECCP Module).....	160		
Special Event Trigger.....	137, 145, 160		
Configuration Bits.....	259		
Context Saving During Interrupts.....	102		
Control Registers			
EECON1 and EECON2.....	62		
TABLAT (Table Latch) Register.....	64		
TBLPTR (Table Pointer) Register.....	64		
Conversion Considerations.....	378		
CPFSEQ.....	292		
CPFSGT.....	293		
CPFSLT.....	293		
D			
Data EEPROM Memory.....	79		
Associated Registers.....	83		
EEADR Register.....	79		
EEADRH Register.....	79		
EECON1 Register.....	79		
EECON2 Register.....	79		
Operation During Code-Protect.....	82		
Protection Against Spurious Write.....	82		

PIC18F6525/6621/8525/8621

Reading.....	81	Baud Rate Generator (BRG)	217
Using.....	82	Associated Registers.....	217
Write Verify	82	Auto-Baud Rate Detect.....	220
Writing To.....	81	Baud Rate Error, Calculating.....	217
Data Memory	47	Baud Rates, Asynchronous Modes	218
General Purpose Registers.....	47	High Baud Rate Select (BRGH Bit)	217
Map for PIC18F6X2X/8X2X Devices	48	Sampling	217
Special Function Registers	47	Synchronous Master Mode.....	227
DAW.....	294	Associated Registers, Receive.....	230
DC and AC Characteristics		Associated Registers, Transmit.....	228
Graphs and Tables	357	Reception	229
DC Characteristics	330	Transmission	227
Power-Down and Supply Current	326	Synchronous Slave Mode.....	231
Supply Voltage.....	325	Associated Registers, Receive.....	232
DCFSNZ	295	Associated Registers, Transmit.....	231
DECF	294	Reception	232
DECFSZ.....	295	Transmission	231
Demonstration Boards		Evaluation and Programming Tools.....	321
PICDEM 1	320	Extended Microcontroller Mode.....	71
PICDEM 17.....	321	External Memory Interface.....	71
PICDEM 18R	321	16-Bit Byte Select Mode.....	75
PICDEM 2 Plus.....	320	16-Bit Byte Write Mode.....	73
PICDEM 3.....	320	16-Bit Mode	73
PICDEM 4.....	320	16-Bit Mode Timing	76
PICDEM LIN	321	16-Bit Word Write Mode	74
PICDEM USB.....	321	PIC18F8X2X External Bus -	
PICDEM.net Internet/Ethernet	320	I/O Port Functions.....	72
Development Support	317	Program Memory Modes and External	
Device Differences	377	Memory Interface.....	71
Direct Addressing.....	57		
Direct Addressing.....	55		
E		F	
ECCP		Flash Program Memory	61
Capture and Compare Modes.....	160	Associated Registers.....	69
Standard PWM Mode.....	160	Control Registers.....	62
Electrical Characteristics.....	323	Erase Sequence	66
Enhanced Capture/Compare/PWM (ECCP)	157	Erasing	66
and Program Memory modes	158	Operation During Code-Protect	69
Capture Mode. See Capture (ECCP Module).		Reading	65
Outputs and Configuration	158	Table Pointer	
Pin Configurations for ECCP1	158	Boundaries Based on Operation	64
Pin Configurations for ECCP2	159	Table Pointer Boundaries	64
Pin Configurations for ECCP3	159	Table Reads and Table Writes	61
PWM Mode. See PWM (ECCP Module).		Write Sequence	67
Timer Resources.....	160	Writing To	67
Use with CCP4 and CCP5.....	158	Protection Against Spurious Writes.....	69
Enhanced PWM Mode. See PWM (ECCP Module).		Unexpected Termination	69
Enhanced Universal Synchronous Asynchronous		Write Verify	69
Receiver Transmitter (EUSART).....	213		
Errata	5	G	
EUSART		General Call Address Support.....	196
Asynchronous Mode	221	GOTO	296
12-Bit Break Transmit and Receive	226		
Associated Registers, Receive	224	H	
Associated Registers, Transmit.....	222	Hardware Multiplier.....	85
Auto-Wake-up on Sync Break	225	Introduction.....	85
Receiver.....	223	Operation	85
Setting Up 9-Bit Mode with		Performance Comparison.....	85
Address Detect	223		
Transmitter.....	221		

PIC18F6525/6621/8525/8621

I	
I/O Ports	103
I ² C Mode	
Associated Registers	212
General Call Address Support	196
Master Mode	
Operation	198
Master Mode Transmit Sequence	198
Read/Write Bit Information (R/W Bit)	186, 187
Serial Clock (RC3/SCK/SCL)	187
ID Locations	259, 274
INCF	296
INCFSZ	297
In-Circuit Debugger	274
Resources (table)	274
In-Circuit Serial Programming (ICSP)	259, 274
Indirect Addressing	57
INDF and FSR Registers	56
Operation	56
Indirect Addressing Operation	57
Indirect File Operand	47
INFSNZ	297
Initialization Conditions for All Registers	32–36
Instruction Flow/Pipelining	45
Instruction Set	
ADDLW	281
ADDWF	281
ADDWFC	282
ANDLW	282
ANDWF	283
BC	283
BCF	284
BN	284
BNC	285
BNN	285
BNOV	286
BNZ	286
BOV	289
BRA	287
BSF	287
BTFSC	288
BTFSS	288
BTG	289
BZ	290
CALL	290
CLRF	291
CLRWDT	291
COMF	292
CPFSEQ	292
CPFSGT	293
CPFSLT	293
DAW	294
DCFSNZ	295
DECF	294
DECFSZ	295
Firmware Instructions	275
General Format	277
GOTO	296
INCF	296
INCFSZ	297
INFSNZ	297
IORLW	298
IORWF	298
LFSR	299
MOVF	299
MOVFF	300
MOVLB	300
MOVLW	301
MOVWF	301
MULLW	302
MULWF	302
NEGF	303
NOP	303
Opcode Field Descriptions	276
POP	304
PUSH	304
RCALL	305
RESET	305
RETFIE	306
RETLW	306
RETURN	307
RLCF	307
RLNCF	308
RRCF	308
RRNCF	309
SETF	309
SLEEP	310
SUBFWB	310
SUBLW	311
SUBWF	311
SUBWFB	312
SWAPF	312
TBLRD	313
TBLWT	314
TSTFSZ	315
XORLW	315
XORWF	316
Summary Table	278
INT Interrupt (RB3/INT3:RB0/INT0). See Interrupt Sources.	
INTCON Registers	89
Inter-Integrated Circuit. See I ² C.	
Interrupt Logic (diagram)	88
Interrupt Sources	259
A/D Conversion Complete	237
Capture Complete (CCP)	151
Compare Complete (CCP)	152
INT0	102
Interrupt-on-Change (RB7:RB4)	106
PORTB, Interrupt-on-Change	102
RB3/INT3:RB0/INT0/FLT0 Pins, External	102
TMR0	102
TMR0 Overflow	133
TMR1 Overflow	135, 137
TMR2 to PR2 Match	142
TMR2 to PR2 Match (PWM)	141, 154, 160
TMR3 Overflow	143, 145
TMR4 to PR4 Match	148
TMR4 to PR4 Match (PWM)	147
Interrupts	87
Control Registers	89
Enable Registers	95
Flag Registers	92
Priority Registers	98
Reset Control Registers	101
IORLW	298
IORWF	298
IPR Registers	98

PIC18F6525/6621/8525/8621

K

Key Features	
Easy Migration	7
Expanded Memory	7
External Memory Interface	7
Other Special Features	7

L

LFSR	299
Low-Voltage Detect	253
Characteristics	333
Converter Characteristics	333
Effects of a Reset	257
Operation	256
Current Consumption	257
During Sleep	257
Reference Voltage Set Point	257
Typical Application	253
Low-Voltage ICSP Programming	274
LVD. See Low-Voltage Detect.	

M

Master SSP (MSSP) Module Overview	173
Master Synchronous Serial Port (MSSP). See MSSP.	
Master Synchronous Serial Port. See MSSP	
Memory	
Mode Memory Access	40
Memory Maps for PIC18F6X2X/8X2X	
Program Memory Modes	41
Memory Organization	
Data Memory	47
Program Memory	39
Modes	39
Memory Programming Requirements	334
Microcontroller Mode	71
Microprocessor Mode	71
Microprocessor with Boot Block Mode	71
Migration from High-End to	
Enhanced Devices	379
Migration from Mid-Range to	
Enhanced Devices	378
MOVF	299
MOVFF	300
MOVLB	300
MOVLW	301
MOVWF	301
MPLAB ASM30 Assembler, Linker, Librarian	318
MPLAB ICD 2 In-Circuit Debugger	319
MPLAB ICE 2000 High-Performance	
Universal In-Circuit Emulator	319
MPLAB ICE 4000 High-Performance	
Universal In-Circuit Emulator	319
MPLAB Integrated Development	
Environment Software	317
MPLAB PM3 Device Programmer	319
MPLINK Object Linker/MPLIB Object Librarian	318
MSSP	173
ACK Pulse	186, 187
Clock Stretching	192
10-Bit Slave Receive Mode (SEN = 1)	192
10-Bit Slave Transmit Mode	192
7-Bit Slave Receive Mode (SEN = 1)	192
7-Bit Slave Transmit Mode	192
Clock Synchronization and the	
CKP bit (SEN = 1)	193

Control Registers (general)	173
Enabling SPI I/O	177
I ² C Mode	182
Acknowledge Sequence Timing	206
Baud Rate Generator	199
Bus Collision	
During a Repeated	
Start Condition	210
Bus Collision During a Start Condition	208
Bus Collision During a Stop Condition	211
Clock Arbitration	200
Effect of a Reset	207
I ² C Clock Rate w/BRG	199
Master Mode	197
Reception	203
Repeated Start Condition Timing	202
Start Condition Timing	201
Transmission	203
Multi-Master Communication, Bus	
Collision and Arbitration	207
Multi-Master Mode	207
Registers	182
Sleep Operation	207
Stop Condition Timing	206
Module Operation	186
Operation	176
Slave Mode	186
Addressing	186
Reception	187
Transmission	187
SPI Master Mode	178
SPI Mode	173
SPI Slave Mode	179
SSPBUF	178
SSPSR	178
TMR2 Output for Clock Shift	141, 142
TMR4 Output for Clock Shift	148
Typical Connection	177
MSSP Module	
SPI Master/Slave Connection	177
MULLW	302
MULWF	302

N

NEGF	303
NOP	303

O

Oscillator Configuration	21
EC	21
ECIO	21
ECIO+PLL	21
ECIO+SPLL	21
HS	21
HS+PLL	21
HS+SPLL	21
LP	21
RC	21
RCIO	21
XT	21
Oscillator Selection	259
Oscillator, Timer1	135, 137, 145
Oscillator, Timer3	143
Oscillator, WDT	267

PIC18F6525/6621/8525/8621

P	
Packaging	373
Details	374
Marking	373
Parallel Slave Port (PSP)	111, 128
Associated Registers	130
RE0/AD8/ $\overline{\text{RD}}$ /P2D Pin	128
RE1/AD9/ $\overline{\text{WR}}$ /P2C Pin	128
RE2/AD10/ $\overline{\text{CS}}$ /P2B Pin	128
Select (PSPMODE Bit)	111, 128
Phase Locked Loop (PLL)	23
PICkit 1 Flash Starter Kit	321
PICSTART Plus Development Programmer	320
PIE Registers	95
Pin Functions	
AVDD	20
AVSS	20
MCLR/VPP/RG5	11
OSC1/CLKI	11
OSC2/CLKO/RA6	11
RA0/AN0	12
RA1/AN1	12
RA2/AN2/VREF-	12
RA3/AN3/VREF+	12
RA4/T0CKI	12
RA5/AN4/LVDIN	12
RA6	12
RB0/INT0/FLT0	13
RB1/INT1	13
RB2/INT2	13
RB3/INT3/ECCP2/P2A	13
RB4/KBI0	13
RB5/KBI1/PGM	13
RB6/KBI2/PGC	13
RB7/KBI3/PGD	13
RC0/T1OSO/T13CKI	14
RC1/T1OSI/ECCP2/P2A	14
RC2/ECCP1/P1A	14
RC3/SCK/SCL	14
RC4/SDI/SDA	14
RC5/SDO	14
RC6/TX1/CK1	14
RC7/RX1/DT1	14
RD0/AD0/PSP0	15
RD1/AD1/PSP1	15
RD2/AD2/PSP2	15
RD3/AD3/PSP3	15
RD4/AD4/PSP4	15
RD5/AD5/PSP5	15
RD6/AD6/PSP6	15
RD7/AD7/PSP7	15
RE0/AD8/ $\overline{\text{RD}}$ /P2D	16
RE1/AD9/ $\overline{\text{WR}}$ /P2C	16
RE2/AD10/ $\overline{\text{CS}}$ /P2B	16
RE3/AD11/P3C	16
RE4/AD12/P3B	16
RE5/AD13/P1C	16
RE6/AD14/P1B	16
RE7/AD15/ECCP2/P2A	16
RF0/AN5	17
RF1/AN6/C2OUT	17
RF2/AN7/C1OUT	17
RF3/AN8	17
RF4/AN9	17
RF5/AN10/CVREF	17
RF6/AN11	17
RF7/ $\overline{\text{SS}}$	17
RG0/ECCP3/P3A	18
RG1/TX2/CK2	18
RG2/RX2/DT2	18
RG3/CCP4/P3D	18
RG4/CCP5/P1D	18
RH0/A16	19
RH1/A17	19
RH2/A18	19
RH3/A19	19
RH4/AN12/P3C	19
RH5/AN13/P3B	19
RH6/AN14/P1C	19
RH7/AN15/P1B	19
RJ0/ALE	20
RJ1/ $\overline{\text{OE}}$	20
RJ2/ $\overline{\text{WRL}}$	20
RJ3/ $\overline{\text{WRH}}$	20
RJ4/BA0	20
RJ5/ $\overline{\text{CE}}$	20
RJ6/ $\overline{\text{LB}}$	20
RJ7/ $\overline{\text{UB}}$	20
VDD	20
Vss	20
Pinout I/O Descriptions	11
PIR Registers	92
PLL Lock Time-out	30
Pointer, FSR	56
POP	304
POR. See Power-on Reset.	
PORTA	
Associated Registers	105
Functions	105
LATA Register	103
PORTA Register	103
TRISA Register	103
PORTB	
Associated Registers	108
Functions	108
LATB Register	106
PORTB Register	106
RB3/INT3:RB0/INT0/FLT0 Pins, External	102
TRISB Register	106
PORTC	
Associated Registers	110
Functions	110
LATC Register	109
PORTC Register	109
RC3/SCK/SCL Pin	187
TRISC Register	109
PORTD	128
Associated Registers	113
Functions	113
LATD Register	111
Parallel Slave Port (PSP) Function	111
PORTD Register	111
TRISD Register	111

PIC18F6525/6621/8525/8621

PORTE		Program Verification	270
Analog Port Pins	128	Programming, Device Instructions.....	275
Associated Registers	116	PSP. See Parallel Slave Port.	
Functions	116	Pulse-Width Modulation. See PWM (CCP Module)	
LATE Register.....	114	and PWM (ECCP Module).	
PORTE Register.....	114	PUSH.....	304
PSP Mode Select (PSPMODE Bit)	111, 128	PWM (CCP Module)	154
RE0/AD8/ \overline{RD} /P2D Pin.....	128	Associated Registers	156
RE1/AD9/ \overline{WR} /P2C Pin.....	128	CCPR4H:CCPR4L Registers	154
RE2/AD10/ \overline{CS} /P2B Pin.....	128	Duty Cycle	154
TRISE Register	114	Example Frequencies/Resolutions	155
PORTF		Period	154
Associated Registers	119	Setup for PWM Operation	155
Functions	119	TMR2 to PR2 Match	141, 154
LATF Register.....	117	TMR4 to PR4 Match	147
PORTF Register	117	PWM (ECCP Module).....	160
TRISF Register	117	Associated Registers	172
PORTG		CCPR1H:CCPR1L Registers	160
Associated Registers	121	Direction Change in Full-Bridge	
Functions	121	Output Mode.....	166
LATG Register	120	Duty Cycle	161
PORTG Register.....	120	Effects of a Reset	171
TRISG Register.....	120	Enhanced PWM Auto-Shutdown	168
PORTH		Example Frequencies/Resolutions	161
Associated Registers	124	Full-Bridge Application Example.....	166
Functions	124	Full-Bridge Mode	165
LATH Register	122	Half-Bridge Mode.....	163
PORTH Register	122	Half-Bridge Output Mode	
TRISH Register.....	122	Applications Example	164
PORTJ		Output Configurations.....	162
Associated Registers	127	Output Relationships (Active-High)	162
Functions	127	Output Relationships (Active-Low)	163
LATJ Register	125	Period	160
PORTJ Register.....	125	Programmable Dead-Band Delay.....	168
TRISJ Register.....	125	Setup for PWM Operation	171
Postscaler, WDT		Start-up Considerations.....	170
Assignment (PSA Bit)	133	TMR2 to PR2 Match	160
Rate Select (T0PS2:T0PS0 Bits)	133		
Switching Between Timer0 and WDT	133	Q	
Power-Down Mode. See Sleep.		Q Clock	154, 161
Power-on Reset (POR)	30, 259	R	
Oscillator Start-up Timer (OST)	30, 259	RAM. See Data Memory.	
Power-up Timer (PWRT)	30, 259	RC Oscillator.....	22
Time-out Sequence.....	30	RCALL	305
Prescaler		RCON Registers.....	101
Timer2.....	161	Register File.....	47
Prescaler, Capture	151	Registers	
Prescaler, Timer0	133	ADCON0 (A/D Control 0).....	233
Assignment (PSA Bit)	133	ADCON1 (A/D Control 1).....	234
Rate Select (T0PS2:T0PS0 Bits)	133	ADCON2 (A/D Control 2).....	235
Switching Between Timer0 and WDT	133	BAUDCONx (Baud Rate Control).....	216
Prescaler, Timer2.....	154	CCPxCON (Capture/Compare/PWM	
PRO MATE II Universal Device Programmer	319	Control - CCP4, CCP5)	149
Product Identification System	393	CCPxCON (Capture/Compare/PWM Control -	
Program Counter		ECCP1, ECCP2, ECCP3 Modules).....	157
PCL, PCLATH and PCLATU Register	44	CMCON (Comparator Control)	243
Program Memory		CONFIG1H (Configuration 1 High).....	260
Extended Microcontroller Mode	39	CONFIG2H (Configuration 2 High).....	261
Instructions.....	45	CONFIG2L (Configuration 2 Low)	261
Two-Word	46	CONFIG3H (Configuration 3 High).....	262
Interrupt Vector	39	CONFIG3L (Configuration 3 Low)	41, 262
Map and Stack for PIC18FX525	40	CONFIG4L (Configuration 4 Low)	263
Map and Stack for PIC18FX621	40	CONFIG5H (Configuration 5 High).....	264
Microcontroller Mode	39	CONFIG5L (Configuration 5 Low)	263
Microprocessor Mode	39	CONFIG6H (Configuration 6 High).....	265
Microprocessor with Boot Block Mode.....	39	CONFIG6L (Configuration 6 Low)	264
Reset Vector	39		

PIC18F6525/6621/8525/8621

CONFIG7H (Configuration 7 High)	266
CONFIG7L (Configuration 7 Low)	265
CVRCON (Comparator Voltage Reference Control)	249
Device ID Register 2	266
DEVID1 (Device ID Register 1)	266
ECCPxAS (ECCP Auto-Shutdown Control)	169
ECCPxDEL (PWM Configuration)	168
EECON1 (Data EEPROM Control 1)	63, 80
INTCON (Interrupt Control)	89
INTCON2 (Interrupt Control 2)	90
INTCON3 (Interrupt Control 3)	91
IPR1 (Peripheral Interrupt Priority 1)	98
IPR2 (Peripheral Interrupt Priority 2)	99
IPR3 (Peripheral Interrupt Priority 3)	100
LVDCON (Low-Voltage Detect Control)	255
MEMCON (Memory Control)	71
OSCCON (Oscillator Control)	25
PIE1 (Peripheral Interrupt Enable 1)	95
PIE2 (Peripheral Interrupt Enable 2)	96
PIE3 (Peripheral Interrupt Enable 3)	97
PIR1 (Peripheral Interrupt Request (Flag) 1)	92
PIR2 (Peripheral Interrupt Request (Flag) 2)	93
PIR3 (Peripheral Interrupt Request (Flag) 3)	94
PSPCON (Parallel Slave Port Control)	129
RCON (Reset Control)	59, 101
RCSTAx (Receive Status and Control)	215
SSPCON1 (MSSP Control 1, I ² C Mode)	184
SSPCON1 (MSSP Control 1, SPI Mode)	175
SSPCON2 (MSSP Control 2, I ² C Mode)	185
SSPSTAT (MSSP Status, I ² C Mode)	183
SSPSTAT (MSSP Status, SPI Mode)	174
STATUS	58
STKPTR (Stack Pointer)	43
Summary	51–54
T0CON (Timer0 Control)	131
T1CON (Timer 1 Control)	135
T2CON (Timer 2 Control)	141
T3CON (Timer3 Control)	143
T4CON (Timer 4 Control)	147
TXSTAx (Transmit Status and Control)	214
WDTCON (Watchdog Timer Control)	267
RESET	305
Reset	29, 259
MCLR Reset (normal operation)	29
MCLR Reset (Sleep)	29
Power-on Reset	29
Programmable Brown-out Reset (BOR)	29
RESET Instruction	29
Stack Full Reset	29
Stack Underflow Reset	29
Watchdog Timer (WDT) Reset	29
RETIE	306
RETLW	306
RETURN	307
Return Address Stack	42
and Associated Registers	43
Revision History	377
RLCF	307
RLNCF	308
RRCF	308
RRNCF	309
S	
SCK	173
SDI	173
SDO	173
Serial Clock, SCK	173
Serial Data In (SDI)	173
Serial Data Out (SDO)	173
Serial Peripheral Interface. See SPI Mode.	
SETF	309
Slave Select (\overline{SS})	173
Slave Select Synchronization	179
SLEEP	310
Sleep	259, 269
Software Simulator (MPLAB SIM)	318
Software Simulator (MPLAB SIM30)	318
Special Event Trigger. See Compare (ECCP Mode).	
Special Event Trigger. See Compare (ECCP Module).	
Special Features of the CPU	259
Configuration Registers	260–266
Special Function Registers	47
Map	49
SPI Mode	
Associated Registers	181
Bus Mode Compatibility	181
Effects of a Reset	181
Master Mode	178
Master/Slave Connection	177
Serial Clock	173
Serial Data In	173
Serial Data Out	173
Slave Mode	179
Slave Select	173
Slave Select Synchronization	179
Sleep Operation	181
SPI Clock	178
\overline{SS}	173
SSPOV	203
SSPOV Status Flag	203
SSPSTAT Register	
R/W Bit	186, 187
Status Bits	
Significance and Initialization Condition for RCON Register	31
SUBFWB	310
SUBLW	311
SUBWF	311
SUBWFB	312
SWAPF	312
T	
T0CON Register	
PSA Bit	133
T0CS Bit	133
T0PS2:T0PS0 Bits	133
T0SE Bit	133
Table Pointer Operations (table)	64
TBLRD	313
TBLWT	314
Time-out in Various Situations	31

PIC18F6525/6621/8525/8621

Timer0.....	131	Bus Collision During a Stop	
16-Bit Mode Timer Reads and Writes.....	133	Condition (Case 1).....	211
Associated Registers.....	133	Bus Collision During a Stop	
Clock Source Edge Select (T0SE Bit).....	133	Condition (Case 2).....	211
Clock Source Select (T0CS Bit).....	133	Bus Collision During Start	
Operation.....	133	Condition (SDA Only).....	208
Overflow Interrupt.....	133	Bus Collision for Transmit and	
Prescaler. See Prescaler, Timer0.		Acknowledge.....	207
Timer1.....	135	Capture/Compare/PWM	
16-Bit Read/Write Mode.....	137	(All ECCP/CCP Modules).....	343
Associated Registers.....	139	CLKO and I/O.....	338
Operation.....	136	Clock Synchronization.....	193
Oscillator.....	135, 137	Clock/Instruction Cycle.....	44
Overflow Interrupt.....	135, 137	EUSART Synchronous	
Special Event Trigger (ECCP).....	137, 160	Receive (Master/Slave).....	353
TMR1H Register.....	135	EUSART Synchronous	
TMR1L Register.....	135	Transmission (Master/Slave).....	353
Use as a Real-Time Clock.....	138	Example SPI Master Mode (CKE = 0).....	345
Timer2.....	141	Example SPI Master Mode (CKE = 1).....	346
Associated Registers.....	142	Example SPI Slave Mode (CKE = 0).....	347
MSSP Clock Shift.....	141, 142	Example SPI Slave Mode (CKE = 1).....	348
Operation.....	141	External Clock (All Modes Except PLL).....	337
Postscaler. See Postscaler, Timer2.		External Memory Bus Timing for Sleep	
PR2 Register.....	141, 154, 160	(Microprocessor Mode).....	77
Prescaler. See Prescaler, Timer2.		External Memory Bus Timing for TBLRD	
TMR2 Register.....	141	(Extended Microcontroller Mode).....	76
TMR2 to PR2 Match Interrupt.....	141, 142, 154, 160	External Memory Bus Timing for TBLRD	
Timer3.....	143	(Microprocessor Mode).....	76
Associated Registers.....	145	Full-Bridge PWM Output.....	165
Operation.....	144	Half-Bridge Output.....	163
Oscillator.....	143, 145	I ² C Bus Data.....	349
Overflow Interrupt.....	143, 145	I ² C Bus Start/Stop Bits.....	349
Special Event Trigger (ECCP).....	145	I ² C Master Mode	
TMR3H Register.....	143	(7 or 10-Bit Transmission).....	204
TMR3L Register.....	143	I ² C Master Mode (7-Bit Reception).....	205
Timer4.....	147	I ² C Master Mode First Start Bit Timing.....	201
Associated Registers.....	148	I ² C Slave Mode (10-Bit Reception, SEN = 0).....	190
MSSP Clock Shift.....	148	I ² C Slave Mode (10-Bit Reception, SEN = 1).....	195
Operation.....	147	I ² C Slave Mode (10-Bit Transmission).....	191
Postscaler. See Postscaler, Timer4.		I ² C Slave Mode (7-Bit Reception, SEN = 0).....	188
PR4 Register.....	147	I ² C Slave Mode (7-Bit Reception, SEN = 1).....	194
Prescaler. See Prescaler, Timer4.		I ² C Slave Mode (7-Bit Transmission).....	189
TMR4 Register.....	147	Low-Voltage Detect.....	256
TMR4 to PR4 Match Interrupt.....	147, 148	Master SSP I ² C Bus Data.....	351
Timing Diagrams		Master SSP I ² C Bus Start/Stop Bits.....	351
A/D Conversion.....	355	Parallel Slave Port (PSP).....	344
Acknowledge Sequence.....	206	Parallel Slave Port (PSP) Read.....	130
Asynchronous Reception.....	224	Parallel Slave Port (PSP) Write.....	129
Asynchronous Transmission.....	222	Program Memory Read.....	339
Asynchronous Transmission		Program Memory Write.....	340
(Back to Back).....	222	PWM Auto-Shutdown (PRSEN = 0,	
Automatic Baud Rate Calculation.....	220	Auto-Restart Disabled).....	170
Auto-Wake-up Bit (WUE) During		PWM Auto-Shutdown (PRSEN = 1,	
Normal Operation.....	225	Auto-Restart Enabled).....	170
Auto-Wake-up Bit (WUE) During Sleep.....	225	PWM Direction Change.....	167
Baud Rate Generator with Clock Arbitration.....	200	PWM Direction Change at Near	
BRG Reset Due to SDA Arbitration		100% Duty Cycle.....	167
During Start Condition.....	209	PWM Output.....	154
Brown-out Reset (BOR).....	341	Repeated Start Condition.....	202
Bus Collision During a Repeated Start		Reset, Watchdog Timer (WDT),	
Condition (Case 1).....	210	Oscillator Start-up Timer (OST)	
Bus Collision During a Repeated Start		and Power-up Timer (PWRT).....	341
Condition (Case 2).....	210	Send Break Character Sequence.....	226
Bus Collision During a Start		Slave Mode General Call Address Sequence	
Condition (SCL = 0).....	209	(7 or 10-Bit Address Mode).....	196

PIC18F6525/6621/8525/8621

Slave Synchronization	179	External Clock Requirements	337
Slow Rise Time (MCLR Tied to VDD via 1 k Ω Resistor).....	38	I ² C Bus Data Requirements (Slave Mode)	350
SPI Mode (Master Mode).....	178	I ² C Bus Start/Stop Bits Requirements (Slave Mode)	349
SPI Mode (Slave Mode with CKE = 0)	180	Master SSP I ² C Bus Data Requirements	352
SPI Mode (Slave Mode with CKE = 1)	180	Master SSP I ² C Bus Start/Stop Bits Requirements	351
Stop Condition Receive or Transmit Mode	206	Parallel Slave Port Requirements.....	344
Synchronous Reception (Master Mode, SREN).....	229	PLL Clock	338
Synchronous Transmission.....	227	Program Memory Read Requirements	339
Synchronous Transmission (Through TXEN)	228	Program Memory Write Requirements	340
Time-out Sequence on POR w/PLL Enabled (MCLR Tied to VDD via 1 k Ω Resistor)	38	Reset, Watchdog Timer, Oscillator Start-up Timer, Power-up Timer and Brown-out Reset Requirements	341
Time-out Sequence on Power-up (MCLR Not Tied to VDD): Case 1	37	Timer0 and Timer1 External Clock Requirements	342
Time-out Sequence on Power-up (MCLR Not Tied to VDD): Case 2	37	TRISE Register PSPMODE Bit.....	111, 128
Time-out Sequence on Power-up (MCLR Tied to VDD via 1 k Ω Resistor)	37	TSTFSZ	315
Timer0 and Timer1 External Clock	342	Two-Word Instructions Example Cases.....	46
Timing for Transition Between Timer1 and OSC1 (EC with PLL Active, SCS1 = 1).....	27	TXSTAx Register BRGH Bit	217
Timing for Transition Between Timer1 and OSC1 (HS with PLL Active, SCS1 = 1).....	27	V	
Transition Between Timer1 and OSC1 (HS, XT, LP).....	26	Voltage Reference Specifications.....	332
Transition Between Timer1 and OSC1 (RC, EC).....	28	W	
Transition from OSC1 to Timer1 Oscillator	26	Wake-up from Sleep	259, 269
Wake-up from Sleep via Interrupt	270	Using Interrupts	269
Timing Specifications	337	Watchdog Timer (WDT).....	259, 267
A/D Conversion Requirements	355	Associated Registers	268
Capture/Compare/PWM Requirements	343	Control Register.....	267
CLKO and I/O Requirements	338	Postscaler	268
EUSART Synchronous Receive Requirements.....	353	Programming Considerations	267
EUSART Synchronous Transmission Requirements.....	353	RC Oscillator.....	267
Example SPI Mode Requirements (Master Mode, CKE = 0)	345	Time-out Period	267
Example SPI Mode Requirements (Master Mode, CKE = 1)	346	WCOL	201, 202, 203, 206
Example SPI Mode Requirements (Slave Mode, CKE = 0)	347	WCOL Status Flag.....	201, 202, 203, 206
Example SPI Slave Mode Requirements (CKE = 1).....	348	WWW, On-Line Support	5
		X	
		XORLW.....	315
		XORWF	316

THE MICROCHIP WEB SITE

Microchip provides online support via our WWW site at www.microchip.com. This web site is used as a means to make files and information easily available to customers. Accessible by using your favorite Internet browser, the web site contains the following information:

- **Product Support** – Data sheets and errata, application notes and sample programs, design resources, user's guides and hardware support documents, latest software releases and archived software
- **General Technical Support** – Frequently Asked Questions (FAQ), technical support requests, online discussion groups, Microchip consultant program member listing
- **Business of Microchip** – Product selector and ordering guides, latest Microchip press releases, listing of seminars and events, listings of Microchip sales offices, distributors and factory representatives

CUSTOMER CHANGE NOTIFICATION SERVICE

Microchip's customer notification service helps keep customers current on Microchip products. Subscribers will receive e-mail notification whenever there are changes, updates, revisions or errata related to a specified product family or development tool of interest.

To register, access the Microchip web site at www.microchip.com, click on Customer Change Notification and follow the registration instructions.

CUSTOMER SUPPORT

Users of Microchip products can receive assistance through several channels:

- Distributor or Representative
- Local Sales Office
- Field Application Engineer (FAE)
- Technical Support
- Development Systems Information Line

Customers should contact their distributor, representative or field application engineer (FAE) for support. Local sales offices are also available to help customers. A listing of sales offices and locations is included in the back of this document.

Technical support is available through the web site at: <http://support.microchip.com>

In addition, there is a Development Systems Information Line which lists the latest versions of Microchip's development systems software products. This line also provides information on how customers can receive currently available upgrade kits.

The Development Systems Information Line numbers are:

1-800-755-2345 – United States and most of Canada

1-480-792-7302 – Other International Locations

PIC18F6525/6621/8525/8621

READER RESPONSE

It is our intention to provide you with the best documentation possible to ensure successful use of your Microchip product. If you wish to provide your comments on organization, clarity, subject matter, and ways in which our documentation can better serve you, please FAX your comments to the Technical Publications Manager at (480) 792-4150.

Please list the following information, and use this outline to provide us with your comments about this document.

To: Technical Publications Manager
RE: Reader Response
Total Pages Sent _____

From: Name _____
Company _____
Address _____
City / State / ZIP / Country _____
Telephone: (_____) _____ - _____ FAX: (_____) _____ - _____

Application (optional):

Would you like a reply? ___Y ___N

Device: PIC18F6525/6621/8525/8621 Literature Number: DS39612B

Questions:

1. What are the best features of this document?

2. How does this document meet your hardware and software development needs?

3. Do you find the organization of this document easy to follow? If not, why?

4. What additions to the document do you think would enhance the structure and subject?

5. What deletions from the document could be made without affecting the overall usefulness?

6. Is there any incorrect or misleading information (what and where)?

7. How would you improve this document?

PIC18F6525/6621/8525/8621

PIC18F6525/6621/8525/8621 PRODUCT IDENTIFICATION SYSTEM

To order or obtain information, e.g., on pricing or delivery, refer to the factory or the listed sales office.

<u>PART NO.</u>	-	<u>X</u>	<u>/XX</u>	<u>XXX</u>	
Device		Temperature Range	Package	Pattern	
Device		PIC18F6525/6621/8525/8621 ⁽¹⁾ , PIC18F6525/6621/8525/8621T ⁽²⁾ ; VDD range 4.2V to 5.5V PIC18LF6X2X/8X2X ⁽¹⁾ , PIC18LF6X2X/8X2XT ⁽²⁾ ; VDD range 2.0V to 5.5V			
Temperature Range		I = -40°C to +85°C (Industrial) E = -40°C to +125°C (Extended)			
Package		PT = TQFP (Thin Quad Flatpack)			
Pattern		QTP, SQTP, Code or Special Requirements (blank otherwise)			
					Examples: a) PIC18LF6621-I/PT 301 = Industrial temp., TQFP package, Extended VDD limits, QTP pattern #301. b) PIC18F8621-E/PT = Extended temp., TQFP package, standard VDD limits.
					Note 1: F = Standard Voltage Range LF = Extended Voltage Range 2: T = in tape and reel



WORLDWIDE SALES AND SERVICE

AMERICAS

Corporate Office

2355 West Chandler Blvd.
Chandler, AZ 85224-6199
Tel: 480-792-7200
Fax: 480-792-7277
Technical Support:
<http://support.microchip.com>
Web Address:
www.microchip.com

Atlanta

Alpharetta, GA
Tel: 770-640-0034
Fax: 770-640-0307

Boston

Westford, MA
Tel: 978-692-3848
Fax: 978-692-3821

Chicago

Itasca, IL
Tel: 630-285-0071
Fax: 630-285-0075

Dallas

Addison, TX
Tel: 972-818-7423
Fax: 972-818-2924

Detroit

Farmington Hills, MI
Tel: 248-538-2250
Fax: 248-538-2260

Kokomo

Kokomo, IN
Tel: 765-864-8360
Fax: 765-864-8387

Los Angeles

Mission Viejo, CA
Tel: 949-462-9523
Fax: 949-462-9608

San Jose

Mountain View, CA
Tel: 650-215-1444
Fax: 650-961-0286

Toronto

Mississauga, Ontario,
Canada
Tel: 905-673-0699
Fax: 905-673-6509

ASIA/PACIFIC

Australia - Sydney

Tel: 61-2-9868-6733
Fax: 61-2-9868-6755

China - Beijing

Tel: 86-10-8528-2100
Fax: 86-10-8528-2104

China - Chengdu

Tel: 86-28-8676-6200
Fax: 86-28-8676-6599

China - Fuzhou

Tel: 86-591-8750-3506
Fax: 86-591-8750-3521

China - Hong Kong SAR

Tel: 852-2401-1200
Fax: 852-2401-3431

China - Shanghai

Tel: 86-21-5407-5533
Fax: 86-21-5407-5066

China - Shenyang

Tel: 86-24-2334-2829
Fax: 86-24-2334-2393

China - Shenzhen

Tel: 86-755-8203-2660
Fax: 86-755-8203-1760

China - Shunde

Tel: 86-757-2839-5507
Fax: 86-757-2839-5571

China - Qingdao

Tel: 86-532-502-7355
Fax: 86-532-502-7205

ASIA/PACIFIC

India - Bangalore

Tel: 91-80-2229-0061
Fax: 91-80-2229-0062

India - New Delhi

Tel: 91-11-5160-8631
Fax: 91-11-5160-8632

Japan - Kanagawa

Tel: 81-45-471-6166
Fax: 81-45-471-6122

Korea - Seoul

Tel: 82-2-554-7200
Fax: 82-2-558-5932 or
82-2-558-5934

Singapore

Tel: 65-6334-8870
Fax: 65-6334-8850

Taiwan - Kaohsiung

Tel: 886-7-536-4818
Fax: 886-7-536-4803

Taiwan - Taipei

Tel: 886-2-2500-6610
Fax: 886-2-2508-0102

Taiwan - Hsinchu

Tel: 886-3-572-9526
Fax: 886-3-572-6459

EUROPE

Austria - Weis

Tel: 43-7242-2244-399
Fax: 43-7242-2244-393

Denmark - Ballerup

Tel: 45-4450-2828
Fax: 45-4485-2829

France - Massy

Tel: 33-1-69-53-63-20
Fax: 33-1-69-30-90-79

Germany - Ismaning

Tel: 49-89-627-144-0
Fax: 49-89-627-144-44

Italy - Milan

Tel: 39-0331-742611
Fax: 39-0331-466781

Netherlands - Drunen

Tel: 31-416-690399
Fax: 31-416-690340

England - Berkshire

Tel: 44-118-921-5869
Fax: 44-118-921-5820