

100V/2A Peak, Low Cost, High Frequency Half Bridge Driver

The HIP2100 is a high frequency, 100V Half Bridge N-Channel MOSFET driver IC, available in 8 lead plastic SOIC. The low-side and high-side gate drivers are independently controlled and matched to 8ns. This gives the user maximum flexibility in dead-time selection and driver protocol. Undervoltage protection on both the low-side and high-side supplies force the outputs low. An on-chip diode eliminates the discrete diode required with other driver ICs. A new level-shifter topology yields the low-power benefits of pulsed operation with the safety of DC operation. Unlike some competitors, the high-side output returns to its correct state after a momentary undervoltage of the high-side supply.

Ordering Information

| PART NUMBER | TEMP. RANGE (°C) | PACKAGE | PKG. NO. |
|-------------|------------------|---------------|----------|
| HIP2100IB | -40°C to 85°C | 8 Ld SOIC (N) | M8.15 |

Features

- Drives N-Channel MOSFET Half Bridge
- Space Saving SO8 Package
- Bootstrap Supply Max Voltage to 116VDC
- On-Chip 1Ω Bootstrap Diode
- Fast Propagation Times Needed for Multi-MHz Circuits
- Drives 1000pF Load at 1MHz with Rise and Fall Times of Typically 10ns
- CMOS Input Thresholds for Improved Noise Immunity
- Independent Inputs for Non-Half Bridge Topologies
- No Start-Up Problems
- Outputs Unaffected by Supply Glitches, HS Ringing Below Ground, or HS Slewing at High dv/dt
- Low Power Consumption
- Wide Supply Range
- Supply Undervoltage Protection
- 3Ω Output Resistance

Applications

- Telecom Half Bridge Power Supplies
- Avionic DC-DC Converters
- Two-Switch Forward Converters
- Active Clamp Forward Converters

Pinout

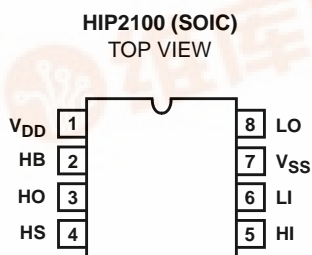

Application Block Diagram

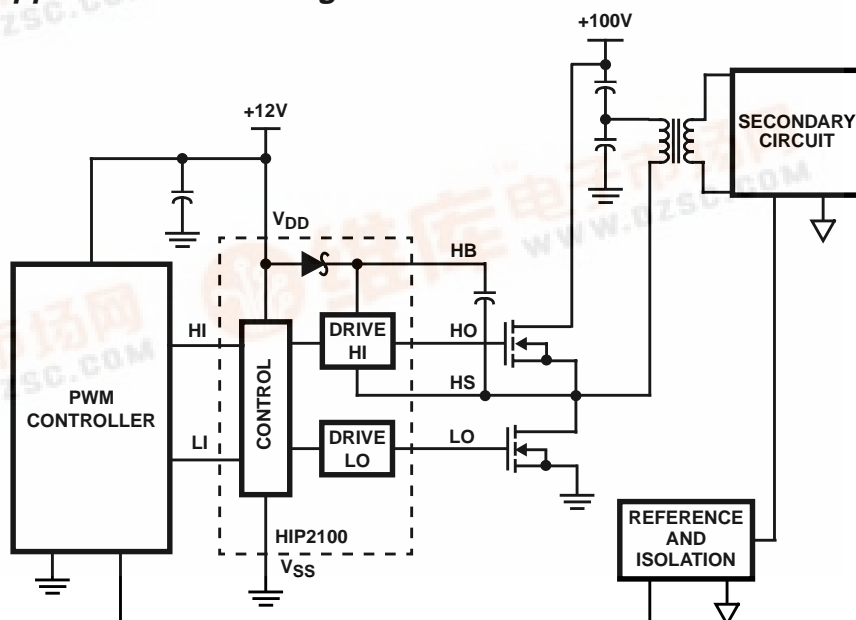

HIP2100

Functional Block Diagram

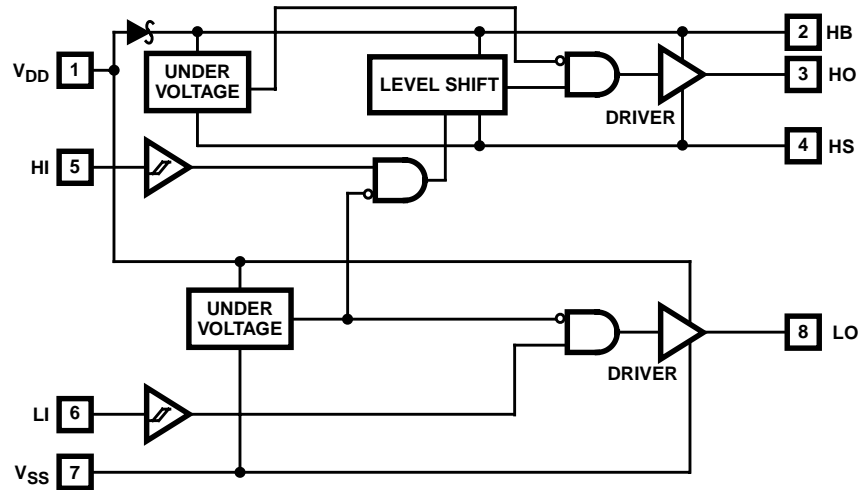

Other Applications

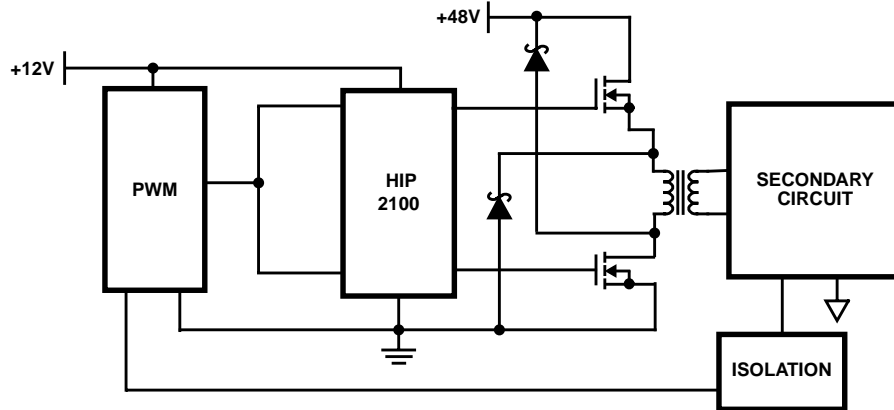

FIGURE 1. TWO-SWITCH FORWARD CONVERTER

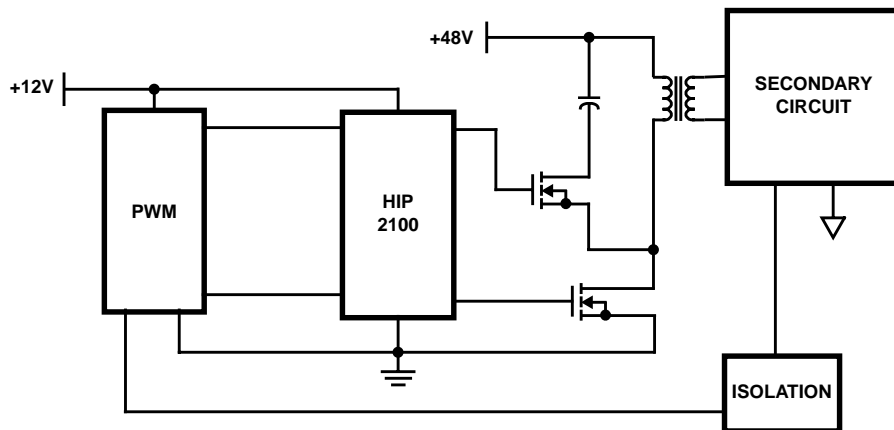

FIGURE 2. FORWARD CONVERTER WITH AN ACTIVE CLAMP

HIP2100

Absolute Maximum Ratings

| | |
|--|----------------------------------|
| Supply Voltage, V_{DD} , V_{HB} - V_{HS} | -0.3V to 18V |
| LI and HI Voltages | -3V to V_{DD} +0.3V |
| Voltage on LO | -0.3V to V_{DD} +0.3V |
| Voltage on HO | V_{HS} -0.3V to V_{HB} +0.3V |
| Voltage on HS (Continuous) | -1V to 110V |
| Voltage on HB | +118V |
| Average Current in V_{DD} to HB diode | 100mA |
| ESD Classification | Class 1 (1kV) |

NOTE: All Voltages Relative to Pin 7, V_{SS} Unless Otherwise Specified

Thermal Information

| | | |
|---|---------------|----------------|
| Thermal Resistance | θ_{JA} | θ_{JC} |
| SOIC | 160°C/W | N/A |
| SOIC in Thermal Conductive Media | | 70°C/W |
| HS Slew Rate | | 10V/ns |
| Storage Temperature Range | | -65°C to 150°C |
| Junction Temperature Range | | -55°C to 150°C |
| Lead Temperature (Soldering 10s - Lead Tips Only) | | 300°C |
| Maximum Power Dissipation at +25°C in Free Air | | 780mW |

CAUTION: Stresses above those listed in "Absolute Maximum Ratings" may cause permanent damage to the device. This is a stress only rating and operation of the device at these or any other conditions above those indicated in the recommended operating conditions of this specification is not implied.

Recommended Operating Conditions

| | | | |
|--------------------------|---------------|--|------------------------------------|
| Supply Voltage, V_{DD} | +9V to +16.5V | Voltage on HS | (Repetitive Transient) -5V to 105V |
| Voltage on HS | -1V to 100V | Voltage on HB V_{HS} +8V to V_{HS} +16.5V and V_{DD} -1V to V_{DD} +100V | |

Electrical Specifications $V_{DD} = V_{HB} = 12V$, $V_{SS} = V_{HS} = 0V$, No Load on LO or HO, Unless Otherwise Specified

| PARAMETERS | SYMBOL | TEST CONDITIONS | $T_J = 25^\circ\text{C}$ | | | $T_J = -40^\circ\text{C}$ TO 125°C | | UNITS |
|------------------------------------|------------|--|--------------------------|------|------|---|-----|---------------|
| | | | MIN | TYP | MAX | MIN | MAX | |
| SUPPLY CURRENTS | | | | | | | | |
| V_{DD} Quiescent Current | I_{DD} | LI = HI = 0V | - | 0.1 | 0.15 | - | 0.2 | mA |
| V_{DD} Operating Current | I_{DDO} | f = 500kHz | - | 1.5 | 2.5 | - | 3 | mA |
| Total HB Quiescent Current | I_{HB} | LI = HI = 0V | - | 0.1 | 0.15 | - | 0.2 | mA |
| Total HB Operating Current | I_{HBO} | f = 500kHz | - | 1.5 | 2.5 | - | 3 | mA |
| HB to V_{SS} Current, Quiescent | I_{HBS} | $V_{HS} = V_{HB} = 116.5V$ | - | 0.05 | 1 | - | 10 | μA |
| HB to V_{SS} Current, Operating | I_{HBSO} | f = 500kHz | - | 0.7 | - | - | - | mA |
| INPUT PINS | | | | | | | | |
| Low Level Input Voltage Threshold | V_{IL} | | 4 | 5.4 | - | 3 | - | V |
| High Level Input Voltage Threshold | V_{IH} | | - | 5.8 | 7 | - | 8 | V |
| Input Voltage Hysteresis | V_{IHYS} | | - | 0.4 | - | - | - | V |
| Input Pulldown Resistance | R_I | | - | 200 | - | 100 | 500 | k Ω |
| UNDER VOLTAGE PROTECTION | | | | | | | | |
| V_{DD} Rising Threshold | V_{DDR} | | 7 | 7.3 | 7.8 | 6.5 | 8 | V |
| V_{DD} Threshold Hysteresis | V_{DDH} | | - | 0.5 | - | - | - | V |
| HB Rising Threshold | V_{HBR} | | 6.5 | 6.9 | 7.5 | 6 | 8 | V |
| HB Threshold Hysteresis | V_{HBH} | | - | 0.4 | - | - | - | V |
| BOOT STRAP DIODE | | | | | | | | |
| Low-Current Forward Voltage | V_{DL} | $I_{V_{DD}-HB} = 100\mu\text{A}$ | - | 0.45 | 0.55 | - | 0.7 | V |
| High-Current Forward Voltage | V_{DH} | $I_{V_{DD}-HB} = 100\text{mA}$ | - | 0.7 | 0.8 | - | 1 | V |
| Dynamic Resistance | R_D | $I_{V_{DD}-HB} = 100\text{mA}$ | - | 0.8 | 1 | - | 1.5 | Ω |
| LO GATE DRIVER | | | | | | | | |
| Low Level Output Voltage | V_{OLL} | $I_{LO} = 100\text{mA}$ | - | 0.25 | 0.3 | - | 0.4 | V |
| High Level Output Voltage | V_{OHL} | $I_{LO} = -100\text{mA}$, $V_{OHL} = V_{DD} - V_{LO}$ | - | 0.25 | 0.3 | - | 0.4 | V |
| Peak Pullup Current | I_{OHL} | $V_{LO} = 0V$ | - | 2 | - | - | - | A |
| Peak Pulldown Current | I_{OLL} | $V_{LO} = 12V$ | - | 2 | - | - | - | A |
| HO GATE DRIVER | | | | | | | | |
| Low Level Output Voltage | V_{OLH} | $I_{HO} = 100\text{mA}$ | - | 0.25 | 0.3 | - | 0.4 | V |
| High Level Output Voltage | V_{OHH} | $I_{HO} = -100\text{mA}$, $V_{OHH} = V_{HB} - V_{HO}$ | - | 0.25 | 0.3 | - | 0.4 | V |
| Peak Pullup Current | I_{OHH} | $V_{HO} = 0V$ | - | 2 | - | - | - | A |
| Peak Pulldown Current | I_{OLH} | $V_{HO} = 12V$ | - | 2 | - | - | - | A |

HIP2100

Switching Specifications

$V_{DD} = V_{HB} = 12V$, $V_{SS} = V_{HS} = 0V$, No Load on LO or HO, Unless Otherwise Specified

| PARAMETERS | SYMBOL | TEST CONDITIONS | $T_J = 25^\circ C$ | | | $T_J = -40^\circ C$ TO $125^\circ C$ | | UNITS |
|---|------------------|------------------|--------------------|-----|-----|---|-----|-------|
| | | | MIN | TYP | MAX | MIN | MAX | |
| Lower Turn-Off Propagation Delay (LI Falling to LO Falling) | t_{LPHL} | | - | 20 | 35 | - | 45 | ns |
| Upper Turn-Off Propagation Delay (HI Falling to HO Falling) | t_{HPLH} | | - | 20 | 35 | - | 45 | ns |
| Lower Turn-On Propagation Delay (LI Rising to LO Rising) | t_{LPLH} | | - | 20 | 35 | - | 45 | ns |
| Upper Turn-On Propagation Delay (HI Rising to HO Rising) | t_{HPLH} | | - | 20 | 35 | - | 45 | ns |
| Delay Matching: Lower Turn-On and Upper Turn-Off | t_{MON} | | - | 2 | 8 | - | 10 | ns |
| Delay Matching: Lower Turn-Off and Upper Turn-On | t_{MOFF} | | - | 2 | 8 | - | 10 | ns |
| Either Output Rise/Fall Time | t_{RC}, t_{FC} | $C_L = 1000pF$ | - | 10 | - | - | - | ns |
| Either Output Rise/Fall Time (3V to 9V) | t_R, t_F | $C_L = 0.1\mu F$ | - | 0.5 | 0.6 | - | 0.8 | us |
| Either Output Rise Time Driving DMOS | t_{RD} | $C_L = IRFR120$ | - | 20 | - | - | - | ns |
| Either Output Fall Time Driving DMOS | t_{FD} | $C_L = IRFR120$ | - | 10 | - | - | - | ns |
| Minimum Input Pulse Width that Changes the Output | t_{PW} | | - | - | - | - | 50 | ns |
| Bootstrap Diode Turn-On or Turn-Off Time | t_{BS} | | - | 10 | - | - | - | ns |

Pin Descriptions

| PIN NUMBER | SYMBOL | DESCRIPTION |
|------------|----------|---|
| 1 | V_{DD} | Positive Supply to lower gate drivers. De-couple this pin to V_{SS} (Pin 7). Bootstrap diode connected to HB (pin 2). |
| 2 | HB | High-Side Bootstrap supply. External bootstrap capacitor is required. Connect positive side of bootstrap capacitor to this pin. Bootstrap diode is on-chip. |
| 3 | HO | High-Side Output. Connect to gate of High-Side power MOSFET. |
| 4 | HS | High-Side Source connection. Connect to source of High-Side power MOSFET. Connect negative side of bootstrap capacitor to this pin. |
| 5 | HI | High-Side input. |
| 6 | LI | Low-Side input. |
| 7 | V_{SS} | Chip negative supply, generally will be ground. |
| 8 | LO | Low-Side Output. Connect to gate of Low-Side power MOSFET. |

Timing Diagrams

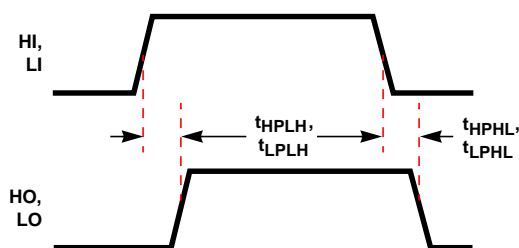

FIGURE 3.

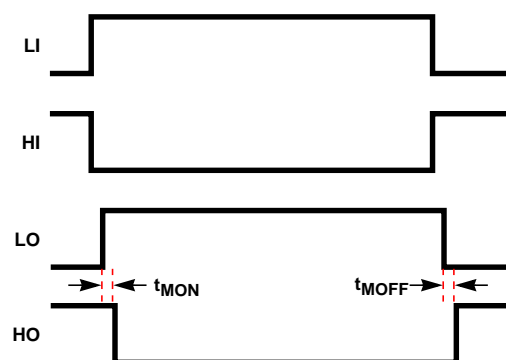

FIGURE 4.

Typical Performance Curves

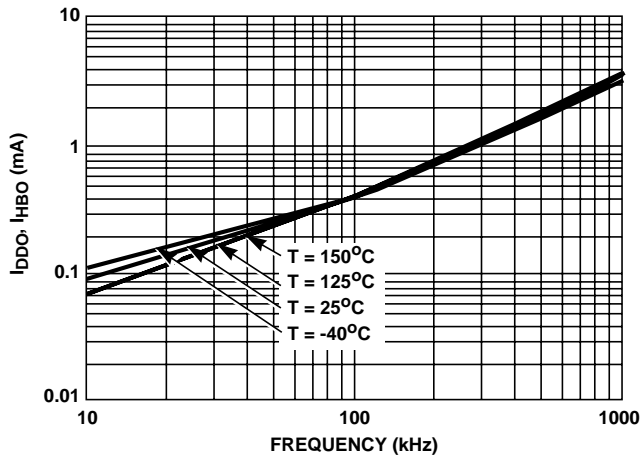

FIGURE 5. OPERATING CURRENT vs FREQUENCY

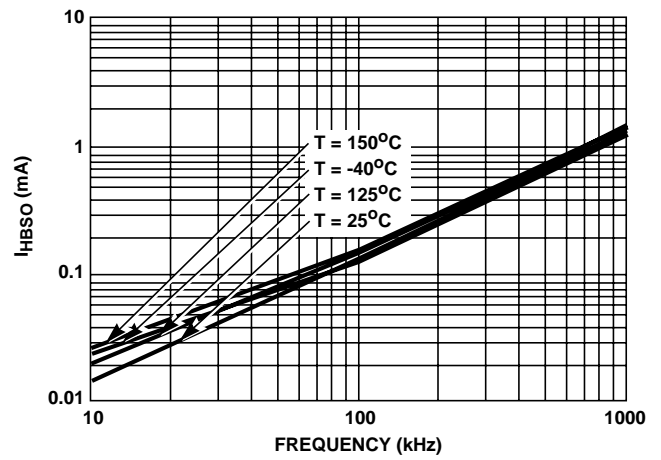

FIGURE 6. LEVEL SHIFTER CURRENT vs FREQUENCY

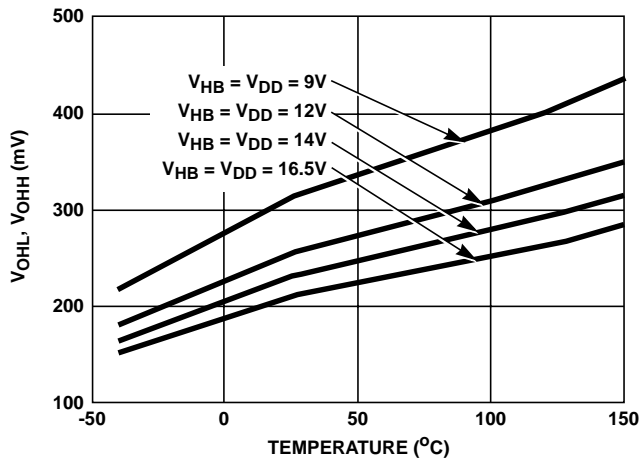

FIGURE 7. HIGH LEVEL OUTPUT VOLTAGE vs TEMPERATURE

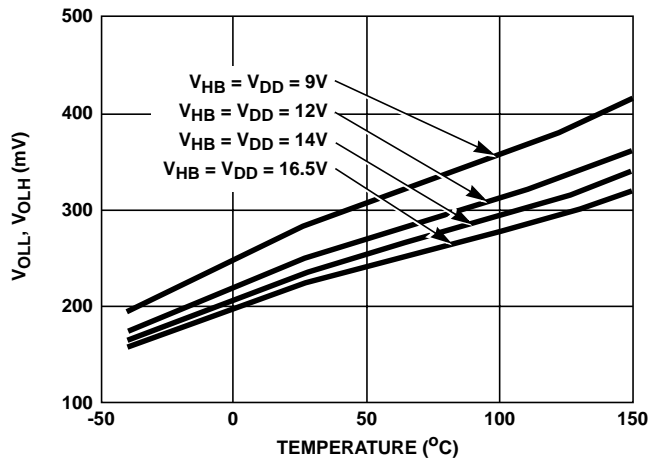

FIGURE 8. LOW LEVEL OUTPUT VOLTAGE vs TEMPERATURE

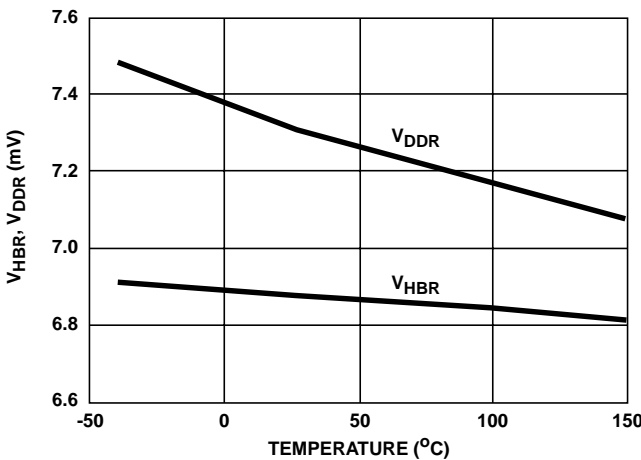

FIGURE 9. UNDERVOLTAGE LOCKOUT THRESHOLD vs TEMPERATURE

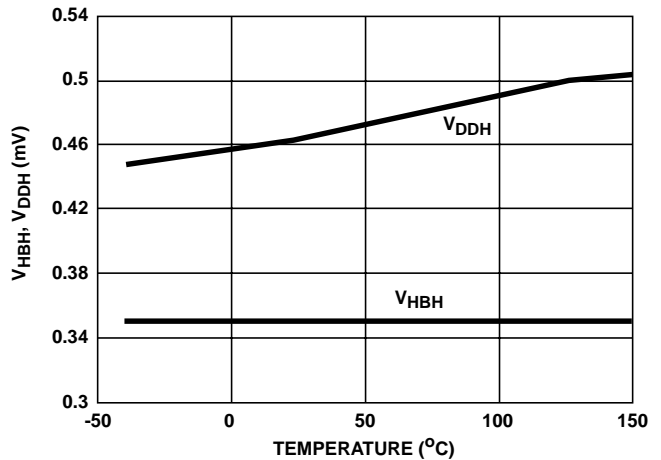

FIGURE 10. UNDERVOLTAGE LOCKOUT HYSTERESIS vs TEMPERATURE

HIP2100

Typical Performance Curves (Continued)

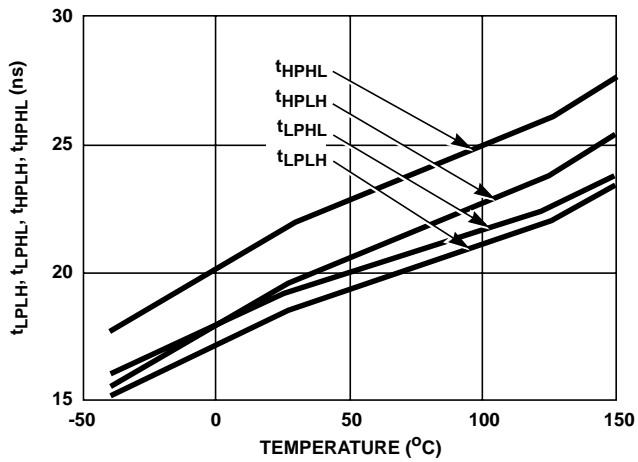

FIGURE 11. PROPAGATION DELAYS vs TEMPERATURE

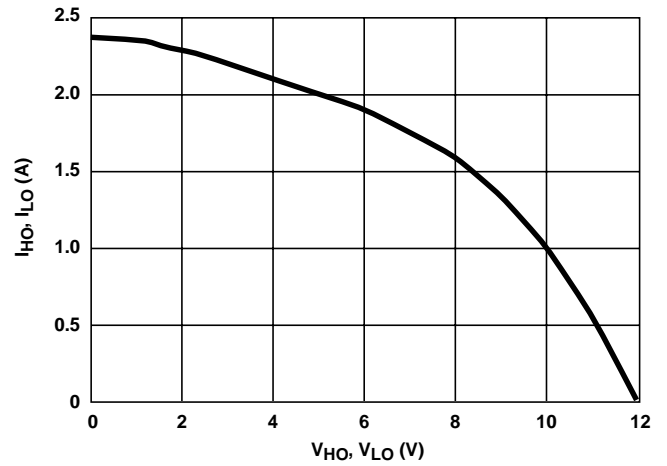

FIGURE 12. PULLUP CURRENT vs OUTPUT VOLTAGE

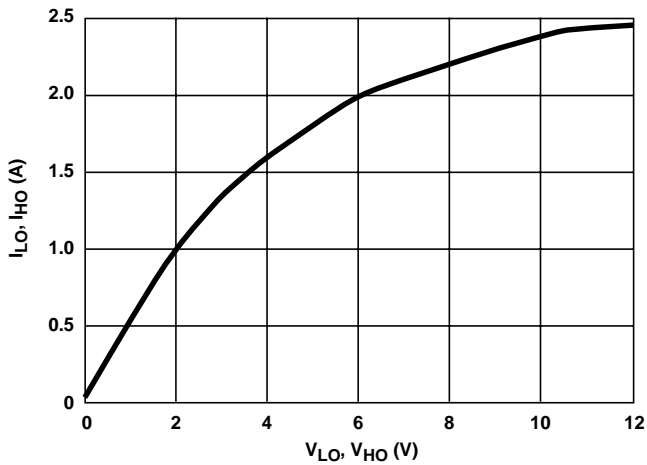

FIGURE 13. PULLDOWN CURRENT vs OUTPUT VOLTAGE

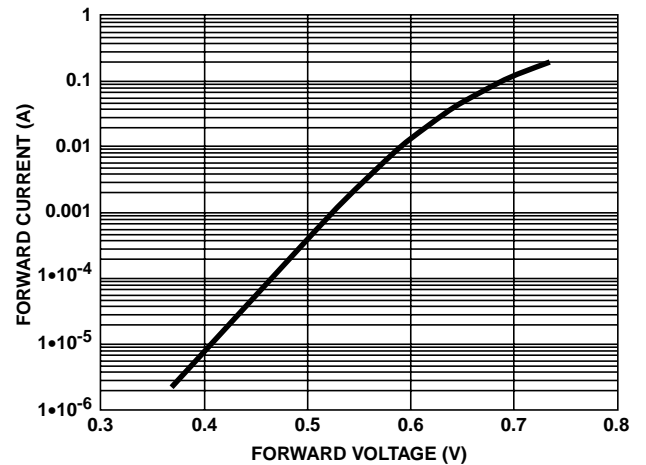

FIGURE 14. BOOTSTRAP DIODE I-V CHARACTERISTICS

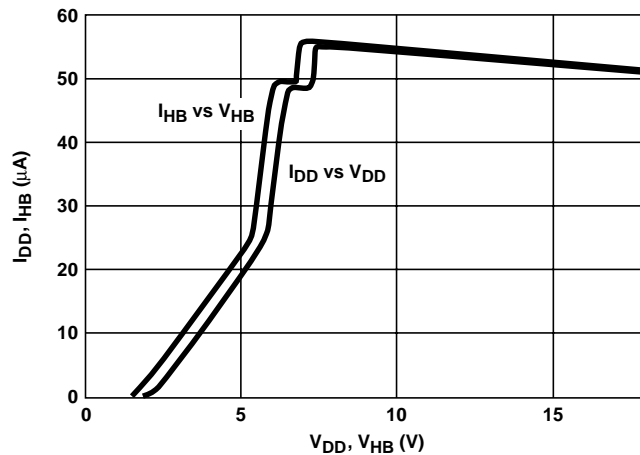

FIGURE 15. BIAS CURRENT vs VOLTAGE

HIP2100

All Intersil semiconductor products are manufactured, assembled and tested under **ISO9000** quality systems certification.

Intersil semiconductor products are sold by description only. Intersil Corporation reserves the right to make changes in circuit design and/or specifications at any time without notice. Accordingly, the reader is cautioned to verify that data sheets are current before placing orders. Information furnished by Intersil is believed to be accurate and reliable. However, no responsibility is assumed by Intersil or its subsidiaries for its use; nor for any infringements of patents or other rights of third parties which may result from its use. No license is granted by implication or otherwise under any patent or patent rights of Intersil or its subsidiaries.

For information regarding Intersil Corporation and its products, see web site <http://www.intersil.com>

Sales Office Headquarters

NORTH AMERICA

Intersil Corporation
P. O. Box 883, Mail Stop 53-204
Melbourne, FL 32902
TEL: (407) 724-7000
FAX: (407) 724-7240

EUROPE

Intersil SA
Mercure Center
100, Rue de la Fusee
1130 Brussels, Belgium
TEL: (32) 2.724.2111
FAX: (32) 2.724.22.05

ASIA

Intersil (Taiwan) Ltd.
7F-6, No. 101 Fu Hsing North Road
Taipei, Taiwan
Republic of China
TEL: (886) 2 2716 9310
FAX: (886) 2 2715 3029