



HT6P20 2²⁴ OTP Encoder

Features

- Operating voltage: 2V~12V
- Low power consumption
- Built-in oscillator needs only 5% resistor
- 0/2/4/8 data selectable
- 2²⁴ maximum address and data codes
- Easy interface with an RF or IR medium
- One time programmable process
- Data active: D0~D7
- Minimal external components
- HT6P20/A/B: 8-pin DIP/NSOP package
HT6P20/D: 16-pin DIP/NSOP package

Applications

- Burglar alarm system
- Smoke and fire alarm system
- Garage door controllers
- Car door controllers
- Security system
- Cordless telephones
- Other remote control systems

General Description

The HT6P20 is a CMOS LSI encoder designed for remote control system applications. It encodes 24 bits of information and then serially transmits it via the DOUT pin upon receipt of transmission enable (DATA pins: D0~D7) signals. The combination of address and data bits of the HT6P20 is designed using one time pro-

grammable process. In addition, the chip offers various packaging for flexible combination of programmable address/data so as to meet various applications. Its programmable address/data is transmitted together with the anti-code bits via RF or infrared transmission medium upon receipt of a trigger signal.

Block Diagram

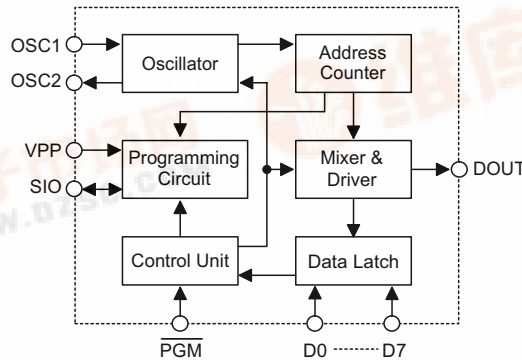

Note: Address/Data numbers are available in various combinations, refer to the functional description.

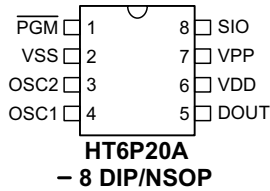
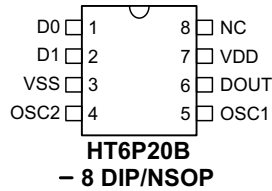
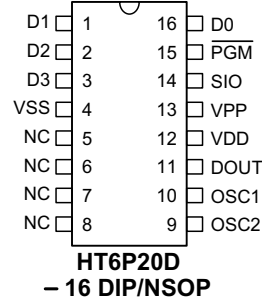
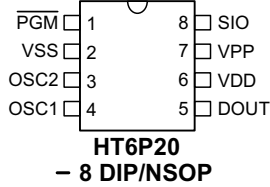
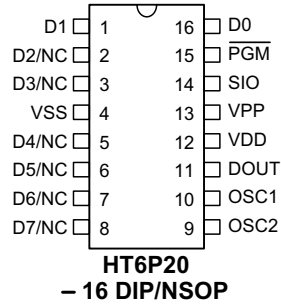

Pin Assignment
**24-Address
0-Data**

**22-Address
2-Data**

**20-Address
4-Data**

Blank device

Blank device

Note: The customer code and control code have been programmed into HT6P20A/B/D by Holtek's factory process.

The blank device HT6P20 is not programmed, it can be programmed by Holtek's programming kit.

Warning: The 8-pin blank device only allows programming as HT6P20A type.

The 16-pin blank device allows programming as one of HT6P20/D type. After programming the HT6P20 pin name are the same as one of HT6P20D, which is determined by the kit programming procedure.

Pin name "NC" stands for no connection (floating).

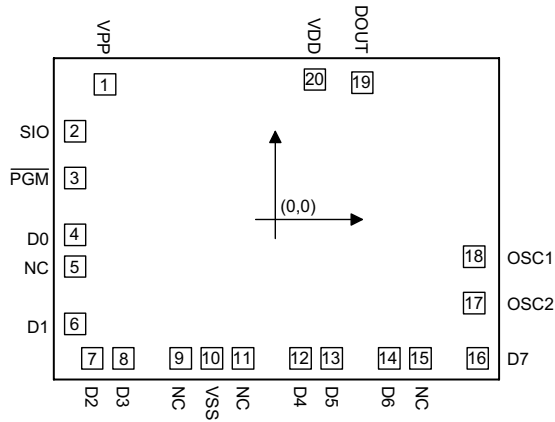
Pad Assignment

Chip size: 2590 × 2010 (μm)²

* The IC substrate should be connected to VSS in the PCB layout artwork.

Pad Coordinates

Unit: μm

Pad No.	X	Y
1	-956.50	762.75
2	-1123.00	498.75
3	-1123.00	236.25
4	-1123.00	-86.25
5	-1123.00	-261.25
6	-1123.00	-583.75
7	-1027.50	-776.75
8	-852.50	-776.75
9	-530.00	-776.75
10	-355.00	-776.75
11	-180.00	-776.75
12	142.50	-776.75
13	317.50	-776.75
14	640.00	-776.75
15	815.00	-776.75
16	1137.50	-776.75
17	1118.00	-466.75
18	1118.00	-205.75
19	489.00	772.05
20	223.50	789.75

Pin Description
HT6P20D

Pin No.	Pin Name	I/O	Internal Connection	Description
16 1~3	D0~D3	I	CMOS IN Pull-high	Data input and transmission enable (active low) They can be externally set to VSS or left open.
4	VSS	—	—	Negative power supply, ground
5~8	NC	—	—	No connection
9	OSC2	O	OSCILLATOR	Oscillator output pin
10	OSC1	I	OSCILLATOR	Oscillator input pin
11	DOUT	O	CMOS OUT	Data serial transmission output
12	VDD	—	—	Positive power supply
13	VPP	I	—	Programming power supply, V _{DD} for normal operation
14	SIO	I/O	CMOS IN/OUT	Programming address/control code input and mode code output for mode verification
15	$\overline{\text{PGM}}$	I	CMOS IN Pull-high	Program mode control pin, active low

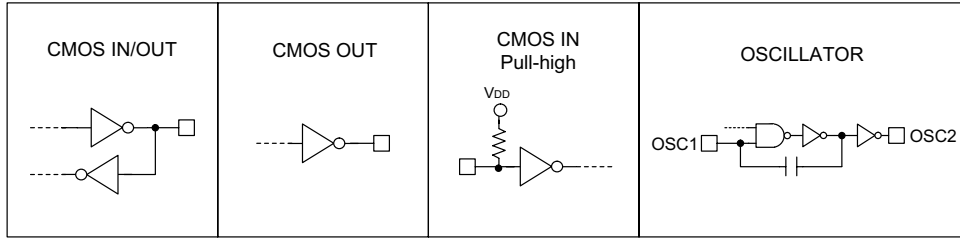
Approximate internal connection circuits

Absolute Maximum Ratings

Supply Voltage-0.3V to 12V	Storage Temperature.....-50°C to 125°C
Input Voltage $V_{SS}-0.3V$ to $V_{DD}+0.3V$	Operating Temperature-20°C to 75°C

Note: These are stress ratings only. Stresses exceeding the range specified under "Absolute Maximum Ratings" may cause substantial damage to the device. Functional operation of this device at other conditions beyond those listed in the specification is not implied and prolonged exposure to extreme conditions may affect device reliability.

Electrical Characteristics
 $T_a=25^\circ\text{C}$

Symbol	Parameter	Test Conditions		Min.	Typ.	Max.	Unit	
		V_{DD}	Conditions					
V_{DD}	Operating Voltage	—	—	2	—	12	V	
I_{STB}	Standby Current	12V	Oscillator stops	—	1	2	μA	
I_{DD}	Operating Current	12V	No load $f_{OSC}=3\text{kHz}$	—	200	400	μA	
V_{IH}	"H" Input Voltage	—	—	$0.8V_{DD}$	—	V_{DD}	V	
V_{IL}	"L" Input Voltage	—	—	0	—	$0.2V_{DD}$	V	
R_{PH}	D0~D7 Pull-high Resistance	12V	—	—	150	300	$\text{k}\Omega$	
I_{DOUT}	Output Current	Source	5V	$0.9V_{DD}$	-2	-5	—	mA
			12V	$0.9V_{DD}$	-6.5	-15	—	mA
		Sink	5V	$0.1V_{DD}$	2	5	—	mA
			12V	$0.1V_{DD}$	6	15	—	mA
f_{OSC}	Oscillator Frequency	12V	$R_{OSC}=1.4\text{M}\Omega$	—	3	—	kHz	

Functional Description

Programming

The HT6P20 is a one time programmable encoding integrated circuit. The programmable codes consist of 4-bit control codes and 24-bit address codes. Before using the device, first program the internal 4 control bits and 24 address bits. Then, to program the address and control codes, connect the PGM pin to VSS, allowing the SIO pin to receive control and address codes from the continuously transmitting programming kit. The control codes (B0~B3) and address timing are respectively shown on the Table and the Figure for Programming Timing. In the programming process, the mode bit (B0) has to be programmed first. The 0/2/4/8 data number is selected by the address along with the data format bits (B1,B2). The HT6P20, in addition, provides a polarity bit (B3) to select the polarity of the output data.

Various packages of the HT6P20 offer programmable combinations of address/data to meet various application needs.

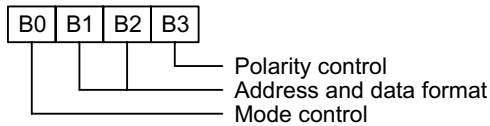

Table 1: Control code

- Mode control (B0)

B0	Function
0	Not programmed
1	Programmed

- Address and data format (B1,B2)

B2	B1	Code Format
0	0	A0~A23
0	1	A0~A21 + D1~D0
1	0	A0~A19 + D3~D0
1	1	A0~A15 + D7~D0

- Polarity control (B3)

B3	Data Output Polarity
0	Negative polarity
1	Positive polarity

The HT6P20A/D can be programmed by the SIO pins. The HT6P20B, on the other hand, is programmed for 2-data and positive polarity application.

Programming timing of the HT6P20D (B0~B3=1010)

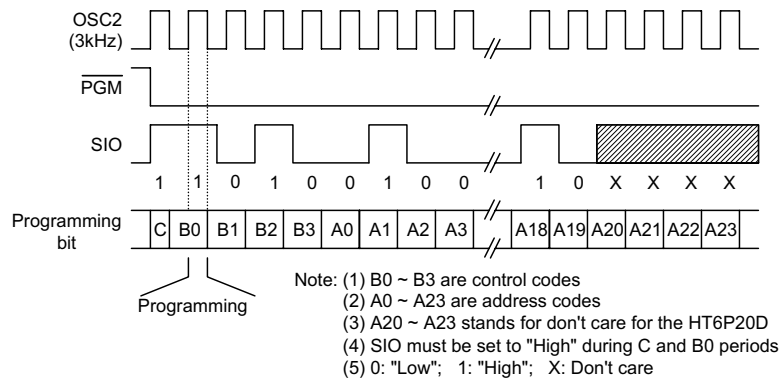

Programming timing for the HT6P20D

Normal operation

The HT6P20 encodes and transmits address/data to a decoder upon receipt of a trigger signal. The address codes of the HT6P20A are always transmitted as long as power (VDD) is supplied. The transmission function of the HT6P20B/D is enabled by the D0~D7 pins (active low). The following is the transmission timing of the HT6P20:

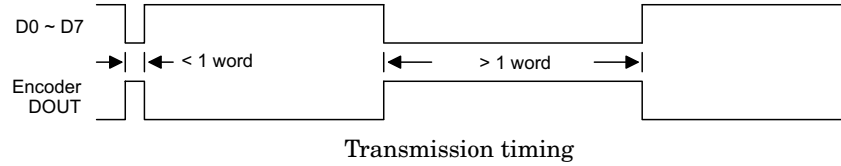

A complete code word of the HT6P20D consists of 3 periods as shown below.

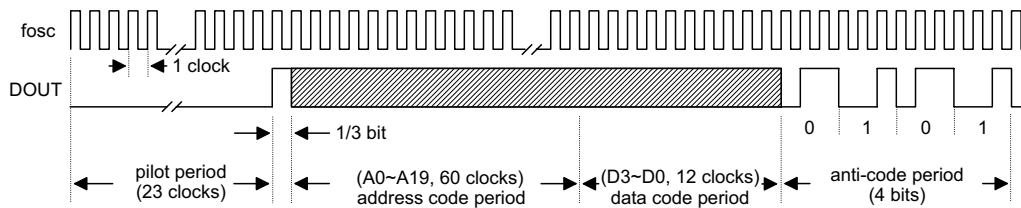

A complete code word for the HT6P20D

The HT6P20A/B/D detects the logic state of the internal programmed address and the external data pins, and then transmits the detected information during the code period. Each address/data bit can be set to one of the following two logic states:

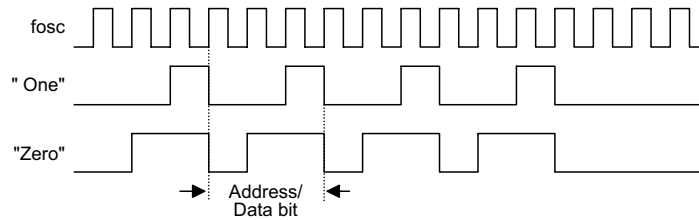

Flowchart

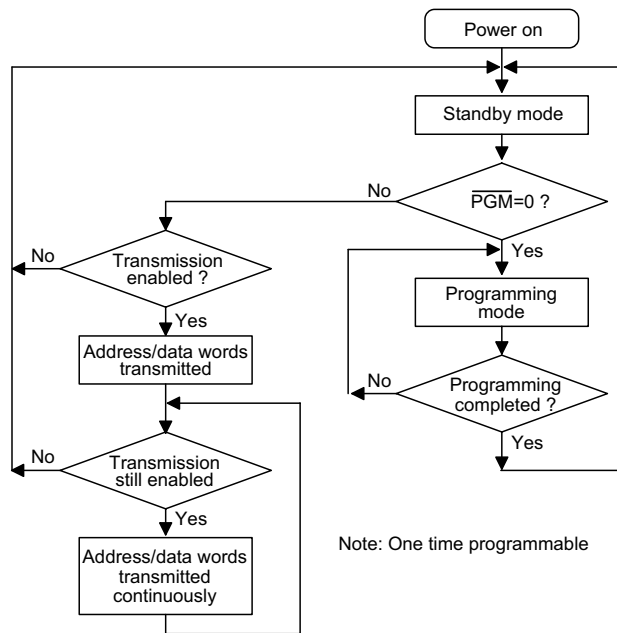

Application Circuits

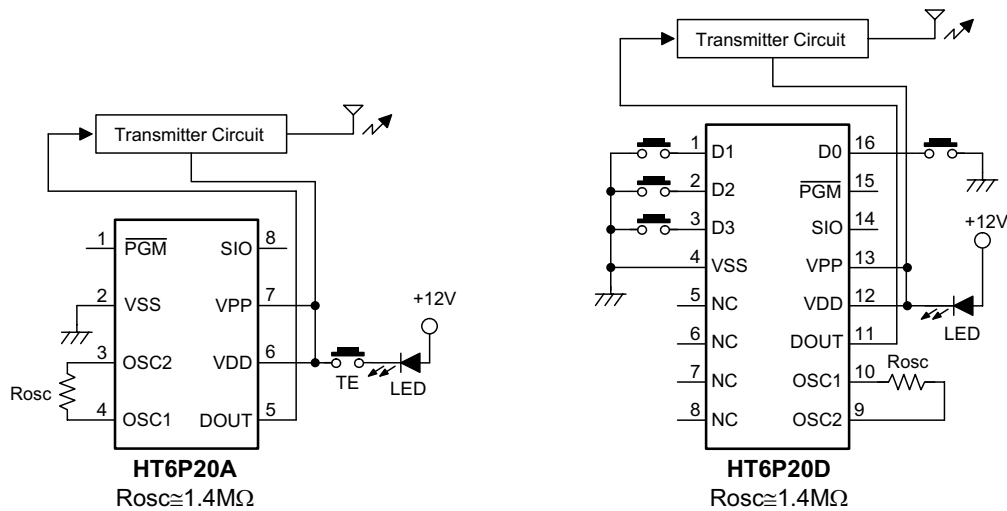

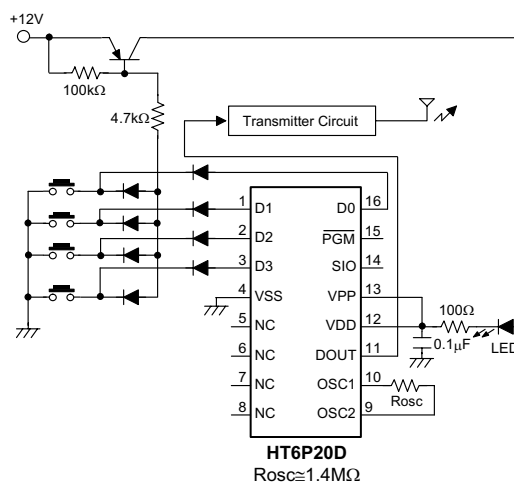
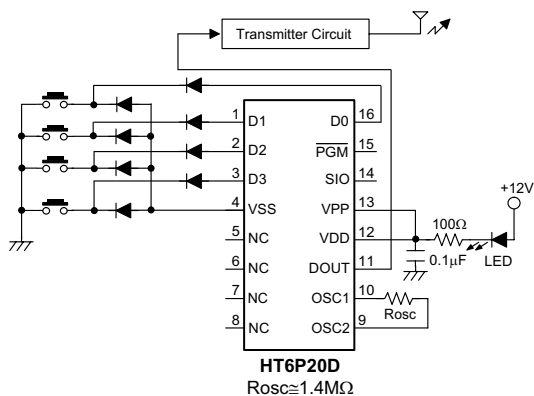
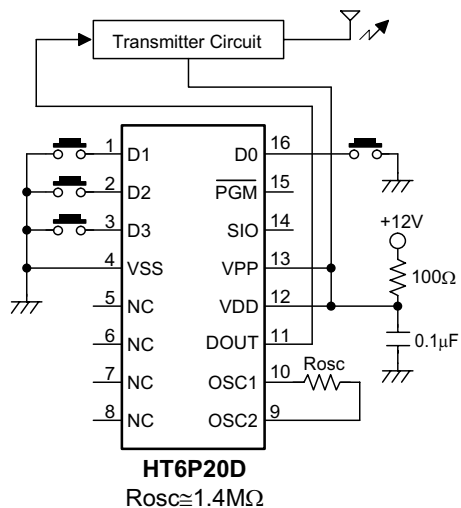

Note: In order to prevent the IC from getting damaged due to the latch up, the 100 Ω resistor or the LED which can also be a transmission indicator is indispensable when V_{DD} =9V~12V.

Holtek Semiconductor Inc. (Headquarters)

No.3 Creation Rd. II, Science-based Industrial Park, Hsinchu, Taiwan, R.O.C.
Tel: 886-3-563-1999
Fax: 886-3-563-1189

Holtek Semiconductor Inc. (Taipei Office)

5F, No.576, Sec.7 Chung Hsiao E. Rd., Taipei, Taiwan, R.O.C.
Tel: 886-2-2782-9635
Fax: 886-2-2782-9636
Fax: 886-2-2782-7128 (International sales hotline)

Holtek Semiconductor (Hong Kong) Ltd.

RM.711, Tower 2, Cheung Sha Wan Plaza, 833 Cheung Sha Wan Rd., Kowloon, Hong Kong
Tel: 852-2-745-8288
Fax: 852-2-742-8657

Copyright © 2000 by HOLTEK SEMICONDUCTOR INC.

The information appearing in this Data Sheet is believed to be accurate at the time of publication. However, Holtek assumes no responsibility arising from the use of the specifications described. The applications mentioned herein are used solely for the purpose of illustration and Holtek makes no warranty or representation that such applications will be suitable without further modification, nor recommends the use of its products for application that may present a risk to human life due to malfunction or otherwise. Holtek reserves the right to alter its products without prior notification. For the most up-to-date information, please visit our web site at <http://www.holtek.com.tw>.