

Low Charge Injection 8-Channel High Voltage Analog Switches with Bleed Resistors

Features

- ❑ HVCMOS® technology for high performance
- ❑ Very low quiescent power dissipation – 10µA
- ❑ Output On-resistance typically 22 ohms
- ❑ Integrated bleed resistors on the outputs
- ❑ Low parasitic capacitances
- ❑ DC to 10MHz analog signal frequency
- ❑ -60dB typical output off isolation at 5MHz
- ❑ CMOS logic circuitry for low power
- ❑ Excellent noise immunity
- ❑ On-chip shift register, latch and clear logic circuitry
- ❑ Flexible high voltage supplies

Applications

- ❑ Medical ultrasound imaging
- ❑ Piezoelectric transducer drivers

Block Diagram

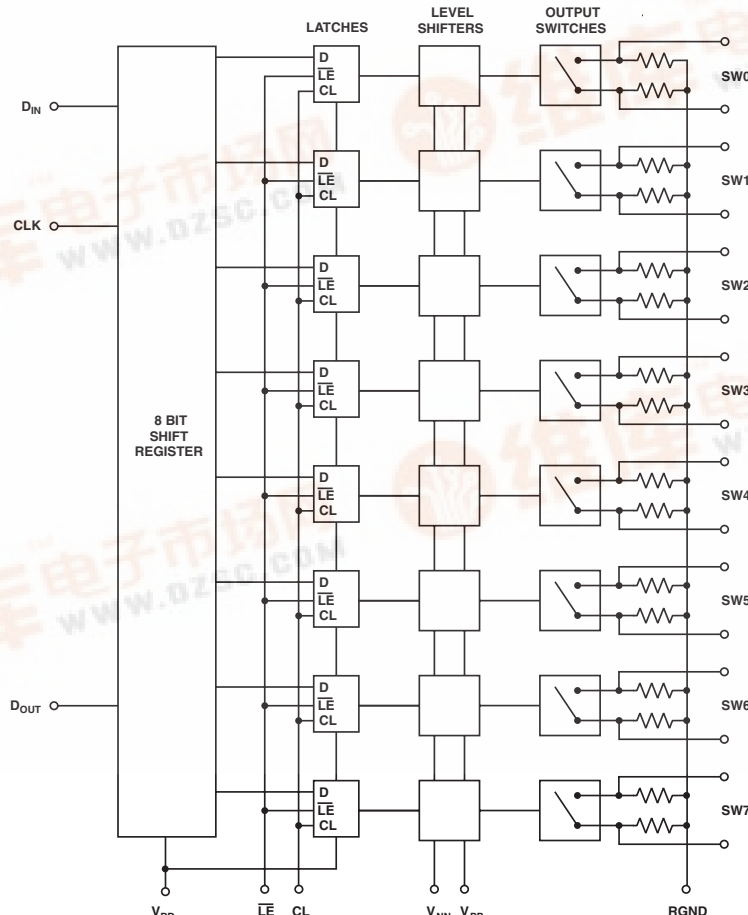

General Description

The Supertex HV230 and HV232 are low charge injection 8-channel high-voltage analog switch integrated circuits (ICs) with bleed resistors. These devices can be used in applications requiring high voltage switching controlled by low voltage control signals, such as ultrasound imaging and printers. The bleed resistors eliminate voltage built up on capacitive loads such as piezoelectric transducers. Input data is shifted into an 8-bit shift register which can then be retained in an 8-bit latch. To reduce any possible clock feed-through noise, Latch Enable Bar (\overline{LE}) should be left high until all bits are clocked in. Using HVCMOS technology, this switch combines high voltage bilateral DMOS switches and low power CMOS logic to provide efficient control of high voltage analog signals.

These ICs are suitable for various combinations of high voltage supplies, e.g., V_{PP}/V_{NN} : +50V/-150V, or +100V/-100V.



Absolute Maximum Ratings*

V_{DD} Logic power supply voltage	-0.5V to +15V
$V_{PP} - V_{NN}$ Supply voltage	220V
V_{PP} Positive high voltage supply	-0.5V to $V_{NN} + 200V$
V_{NN} Negative high voltage supply	+0.5V to -200V
Logic input voltages	-0.5V to $V_{DD} + 0.3V$
Analog Signal Range	V_{NN} to V_{PP}
Peak analog signal current/channel	3.0A
Storage temperature	-65°C to +150°C
Power dissipation:	
28-lead PLCC	1.2W
48-lead TQFP	1.0W
26-lead TAPP	1.0W
26-lead μ -BGA	1.0W

* Absolute Maximum Ratings are those values beyond which damage to the device may occur. Functional operation under these conditions is not implied. Continuous operation of the device at the absolute rating level may affect device reliability. All voltages are referenced to device ground.

Operating Conditions*

Symbol	Parameter	Value
V_{DD}	Logic power supply voltage ^{1, 3}	4.5V to 13.2V
V_{PP}	Positive high voltage supply ^{1, 3}	40V to $V_{NN} + 200V$
V_{NN}	Negative high voltage supply ^{1, 3}	-40V to -160V
V_{IH}	High-level input voltage	$V_{DD} - 1.5V$ to V_{DD}
V_{IL}	Low-level input voltage	0V to 1.5V
V_{SIG}	Analog signal voltage peak to peak	$V_{NN} + 10V$ to $V_{PP} - 10V^2$
T_A	Operating free air-temperature	0°C to 70°C

Notes:

- 1 Power up/down sequence is arbitrary except GND must be powered-up first and powered-down last.
- 2 V_{SIG} must be $V_{NN} - V_{SIG} - V_{PP}$ or floating during power up/down transition.
- 3 Rise and fall times of power supplies V_{DD} , V_{PP} , and V_{NN} should not be less than 1.0msec.

Ordering Information

Package Options					$V_{PP} - V_{NN}$
28-Lead plastic chip carrier	48-Lead TQFP	26-lead TAPP	26-lead μ -BGA	Die	
HV232PJ	HV232FG	-	HV232GA	HV232X	200V
-	-	HV230TA	-	-	200V

Truth Table

D0	D1	D2	D3	D4	D5	D6	D7	\overline{LE}	CL	SW0	SW1	SW2	SW3	SW4	SW5	SW6	SW7	
L								L	L	OFF								
H								L	L	ON								
	L							L	L		OFF							
	H							L	L		ON							
		L						L	L			OFF						
		H						L	L			ON						
			L					L	L				OFF					
			H					L	L				ON					
				L				L	L					OFF				
				H				L	L					ON				
					L			L	L						OFF			
					H			L	L						ON			
						L		L	L								OFF	
							H	L	L								ON	
X	X	X	X	X	X	X	X	H	L	HOLD PREVIOUS STATE								
X	X	X	X	X	X	X	X	X	H	OFF	OFF	OFF	OFF	OFF	OFF	OFF	OFF	OFF

Notes:

1. The eight switches operate independently.
2. Serial data is clocked in on the L to H transition CLK.
3. The switches go to a state retaining their present condition at the rising edge of \overline{LE} . When \overline{LE} is low the shift register data flows through the latch.
4. D_{OUT} is high when data in shift register 7 is high.
5. Shift register clocking has no effect on the switch states if \overline{LE} is H.
6. The clear input overrides all other inputs.

Electrical Characteristics

DC Characteristics (over recommended operating conditions unless otherwise noted)

Characteristics	Sym	0°C		+25°C			+70°C		Units	Test Conditions	
		min	max	min	typ*	max	min	max			
Small Signal Switch (ON) Resistance	R _{ONS}		30		26	38		48	Ω	I _{SIG} = 5mA	V _{PP} = 40V, V _{NN} = -160V
			25		22	27		32		I _{SIG} = 200mA	V _{NN} = -100V
			25		22	27		30		I _{SIG} = 5mA	V _{PP} = 100V, V _{NN} = -100V
			18		18	24		27		I _{SIG} = 200mA	V _{NN} = -100V
			23		20	25		30		I _{SIG} = 5mA	V _{PP} = 160V, V _{NN} = -40V
			22		16	25		27		I _{SIG} = 200mA	V _{NN} = -40V
Small Signal Switch (ON) Resistance Matching	ΔR _{ONS}		20		5.0	20		20	%	I _{SW} = 5mA, V _{PP} = 100V, V _{NN} = -100V	
Large Signal Switch (ON) Resistance	R _{ONL}				15				Ω	V _{SIG} = V _{PP} - 10V, I _{SIG} = 1A	
Output Switch Shunt Resistance	R _{INT}			20	35	50			KΩ	Output switch to R _{GND} I _{RINT} = 0.5mA	
Switch Off Leakage Per Switch	I _{SOL}		5.0		1.0	10		15	μA	V _{SIG} = V _{PP} - 10V	
DC Offset Switch Off			300		100	300		300	mV	No Load	
DC Offset Switch On			500		100	500		500	mV	No Load	
Pos. HV Supply Current	I _{PPQ}				10	50			μA	ALL SWs OFF	
Neg. HV Supply Current	I _{NNQ}				-10	-50			μA	ALL SWs OFF	
Pos. HV Supply Current	I _{PPQ}				10	50			μA	ALL SWs ON, I _{SW} = 5mA	
Neg. HV Supply Current	I _{NNQ}				-10	-50			μA	ALL SWs ON, I _{SW} = 5mA	
Switch Output Peak Current			3.0		3.0	2.0		2.0	A	V _{SIG} duty cycle - 0.1%	
Output Switch Frequency	f _{SW}					50			KHz	Duty Cycle = 50%	
I _{PP} Supply Current	I _{PP}		6.5			7.0		8.0	mA	V _{PP} = 40V, V _{NN} = -160V	50KHz Output Switching Frequency with no load
			4.0			5.0		5.5		V _{PP} = 100V, V _{NN} = -100V	
			4.0			5.0		5.5		V _{PP} = 160V, V _{NN} = -40V	
I _{NN} Supply Current	I _{NN}		6.5			7.0		8.0	mA	V _{PP} = 40V, V _{NN} = -160V	
			4.0			5.0		5.5		V _{PP} = 100V, V _{NN} = -100V	
			4.0			5.0		5.5		V _{PP} = 160V, V _{NN} = -40V	
Logic Supply Average Current	I _{DD}		4.0			4.0		4.0	mA	f _{CLK} = 5MHz, V _{DD} = 5.0V	
Logic Supply Quiescent Current	I _{DDQ}		10			10		10	μA		
Data Out Source Current	I _{SOR}	0.45		0.45	0.70		0.40		mA	V _{OUT} = V _{DD} - 0.7V	
Data Out Sink Current	I _{SINK}	0.45		0.45	0.70		0.40		mA	V _{OUT} = 0.7V	
Logic Input Capacitance	C _{IN}		10			10		10	pF		

*Typical values only for HV232

Electrical Characteristics

AC Characteristics (over operating conditions $V_{DD} = 5V$, unless otherwise noted)

Characteristics	Sym	0°C		+25°C			+70°C		Units	Test Conditions
		min	max	min	typ*	max	min	max		
Set Up Time Before \overline{LE} Rises	t_{SD}	150		150			150		ns	
Time Width of \overline{LE}	t_{WLE}	150		150			150		ns	
Clock Delay Time to Data Out	t_{DO}	55	150	60		150	70	150	ns	
Time Width of CL	t_{WCL}	150		150			150		ns	
Set Up Time Data to Clock	t_{SU}	15		15	8.0		20		ns	
Hold Time Data from Clock	t_h	35		35			35		ns	
Clock Freq	f_{CLK}		5.0			5.0		5.0	MHz	50% duty cycle $f_{DATA} = f_{CLK}/2$
Clock Rise and Fall Times	t_r, t_f		1.0			1.0		1.0	μs	
Turn On Time	t_{ON}		5.0			5.0		5.0	μs	$V_{SIG} = V_{PP} - 10V$, $R_L = 10K\Omega$
Turn Off Time	t_{OFF}		5.0			5.0		5.0	μs	$V_{SIG} = V_{PP} - 10V$, $R_L = 10K\Omega$
Maximum V_{SIG} Slew Rate	dv/dt		20			20		20	V/ns	$V_{PP} = 160V$, $V_{NN} = -40V$
			20			20		20		$V_{PP} = 100V$, $V_{NN} = -100V$
			20			20		20		$V_{PP} = 40V$, $V_{NN} = -160V$
Off Isolation	KO	-30		-30	-33		-30		dB	$f = 5MHz$, 1K Ω /15pF load
		-58		-58			-58			$f = 5MHz$, 50 Ω load
Switch Crosstalk	K_{CR}	-60		-60	-70		-60		dB	$f = 5MHz$, 50 Ω load
Output Switch Isolation Diode Current	I_{ID}		300			300		300	mA	300ns pulse width, 2.0% duty cycle
Off Capacitance SW to GND	$C_{SG(OFF)}$	5.0	17	5.0	12	17	5.0	17	pF	0V, 1MHz
On Capacitance SW to GND	$C_{SG(ON)}$	25	50	25	38	50	25	50	pF	0V, 1MHz

*Typical values only for HV232

Electrical Characteristics

AC Characteristics (over operating conditions $V_{DD} = 5V$, unless otherwise noted)

Characteristics	Sym	+25°C			Units	Test Conditions
		min	typ*	max		
Output Voltage Spike	$+V_{SPK}$			150	mV	$V_{PP} = 40V, V_{NN} = -160V, R_L = 50\Omega$
	$-V_{SPK}$			150		
	$+V_{SPK}$			150		$V_{PP} = 100V, V_{NN} = -100V, R_L = 50\Omega$
	$-V_{SPK}$			150		
	$+V_{SPK}$			150		$V_{PP} = 160V, V_{NN} = -40V, R_L = 50\Omega$
	$-V_{SPK}$			150		

*Typical values only for HV232

Test Circuits

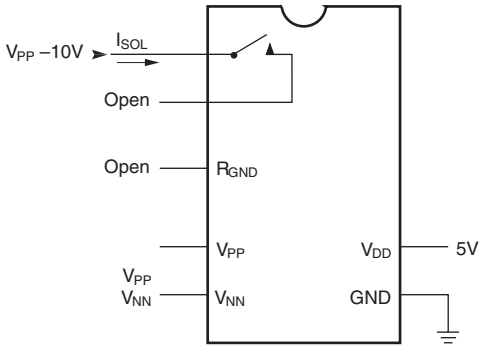

Switch OFF Leakage

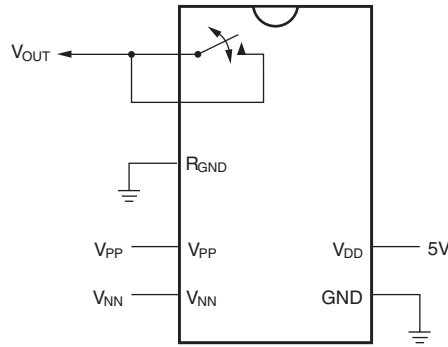

DC Offset ON/OFF

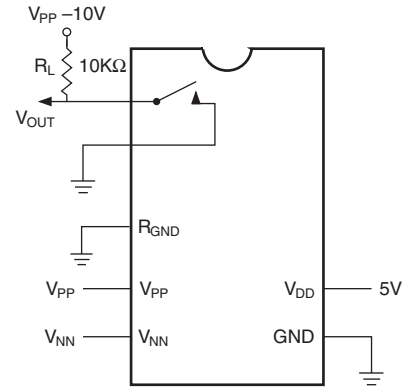

T_{ON}/T_{OFF} Test Circuit

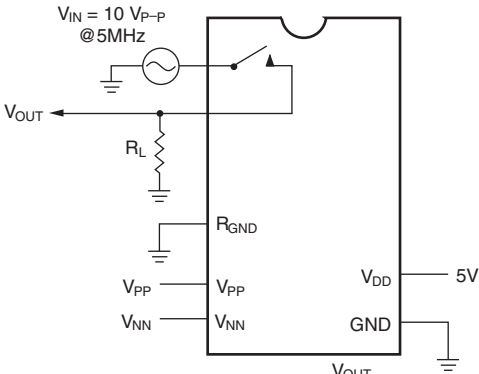

$K_O = 20 \text{Log} \frac{V_{OUT}}{V_{IN}}$
OFF Isolation

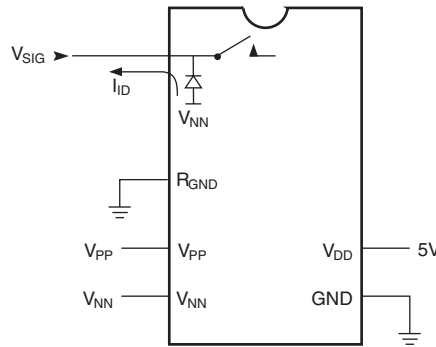

Isolation Diode Current

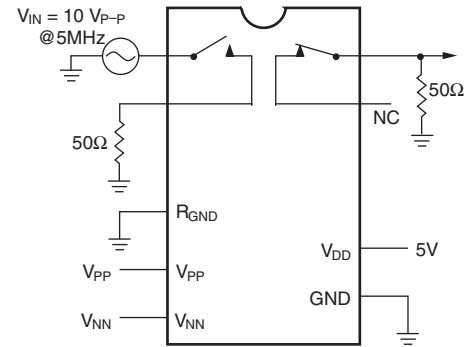

$K_{CR} = 20 \text{Log} \frac{V_{OUT}}{V_{IN}}$
Crosstalk

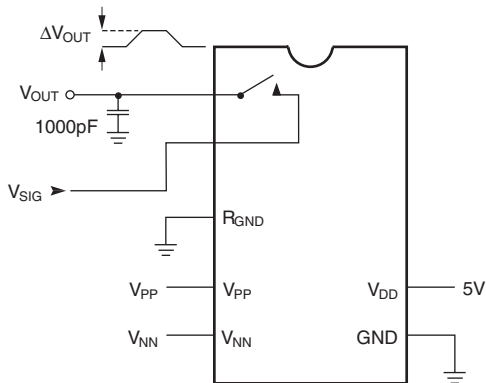

$Q = 1000 \text{pF} \times \Delta V_{OUT}$
Charge Injection

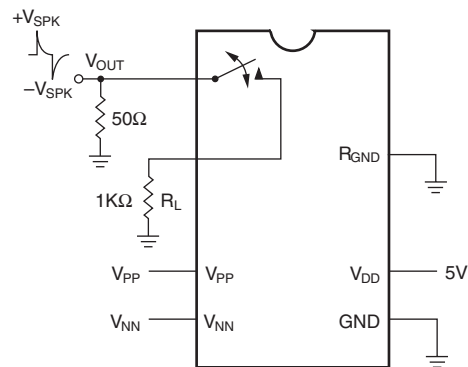

Output Voltage Spike

Logic Timing Waveforms

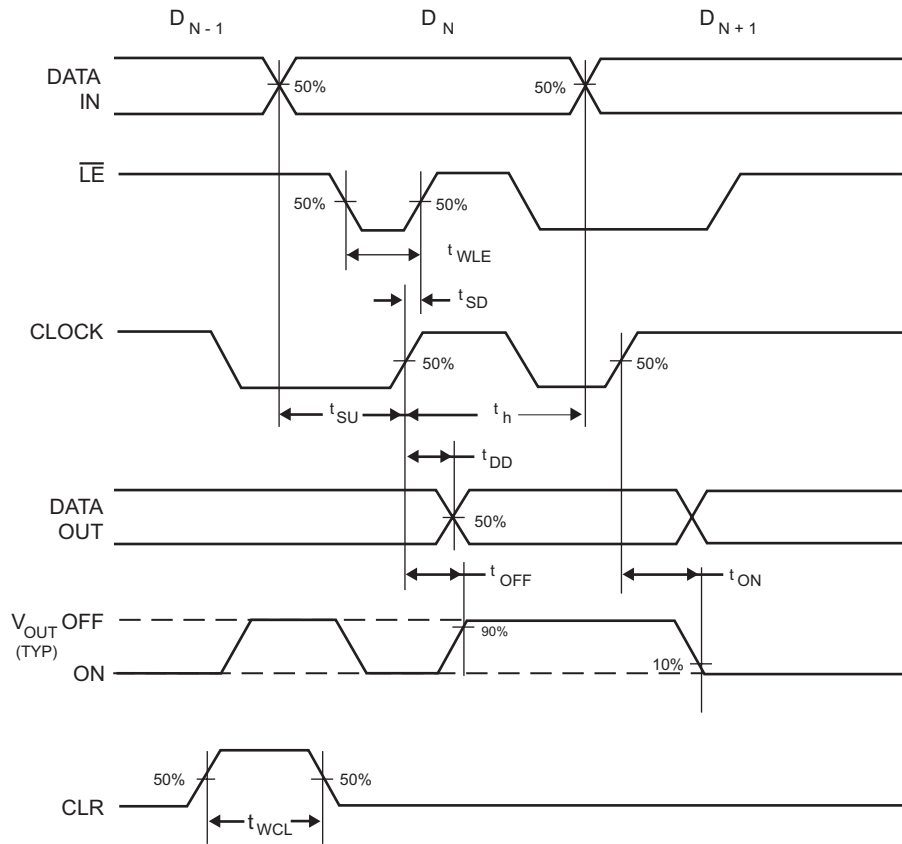

Block Diagram

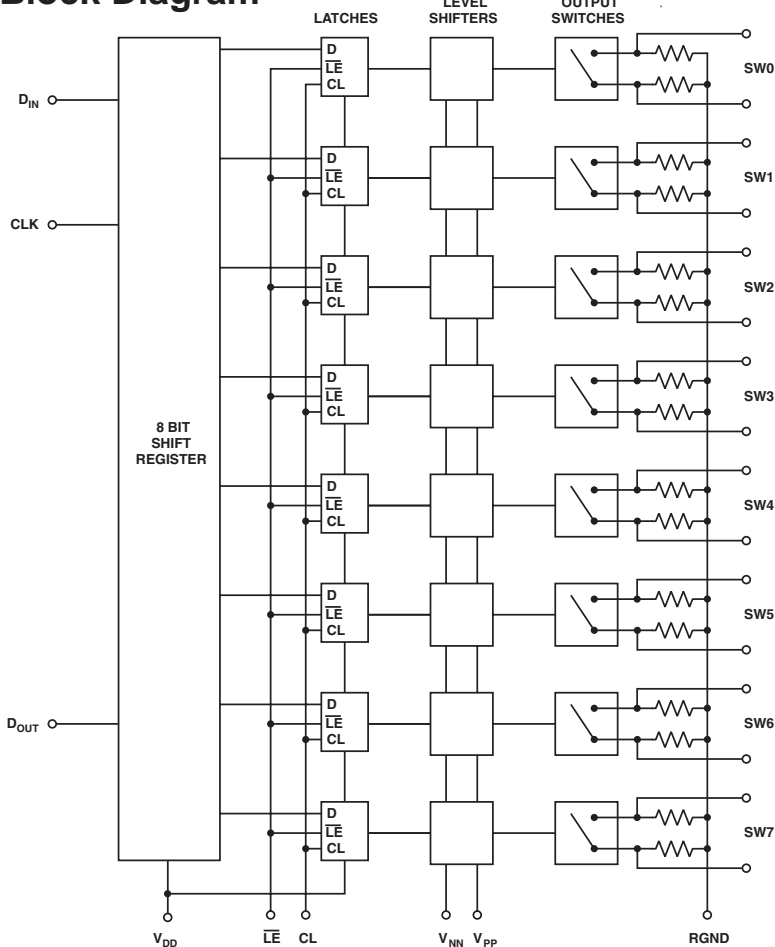

Pin Configurations

Package Outlines

HV232 28-Pin J-Lead

Pin	Function	Pin	Function
1	SW3	15	N/C
2	SW3	16	D _{IN}
3	SW2	17	CLK
4	SW2	18	LE
5	SW1	19	CL
6	SW1	20	D _{OUT}
7	SW0	21	SW7
8	SW0	22	SW7
9	N/C	23	SW6
10	V _{PP}	24	SW6
11	R _{GND}	25	SW5
12	V _{NN}	26	SW5
13	GND	27	SW4
14	V _{DD}	28	SW4

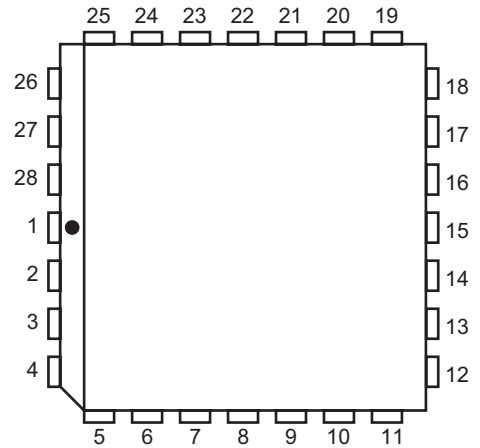

Top View
28-Pin J-Lead Package

HV232 48-Pin TQFP

Pin	Function	Pin	Function
1	SW5	25	V _{NN}
2	N/C	26	N/C
3	SW4	27	R _{GND}
4	N/C	28	GND
5	SW4	29	V _{DD}
6	N/C	30	N/C
7	N/C	31	N/C
8	SW3	32	N/C
9	N/C	33	D _{IN}
10	SW3	34	CLK
11	N/C	35	LE
12	SW2	36	CLR
13	N/C	37	D _{OUT}
14	SW2	38	N/C
15	N/C	39	SW7
16	SW1	40	N/C
17	N/C	41	SW7
18	SW1	42	N/C
19	N/C	43	SW6
20	SW0	44	N/C
21	N/C	45	SW6
22	SW0	46	N/C
23	N/C	47	SW5
24	V _{PP}	48	N/C

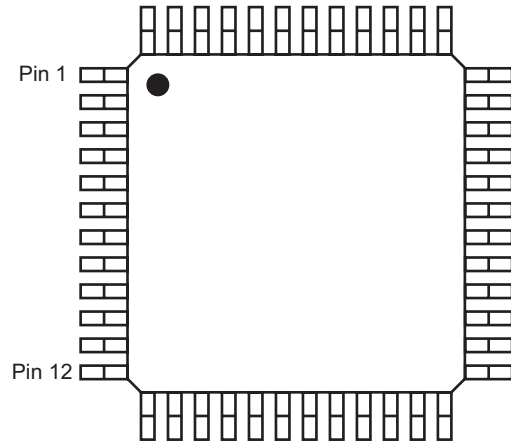

Top View
48-Pin TQFP

HV232GA Package Outline (μ -BGA)

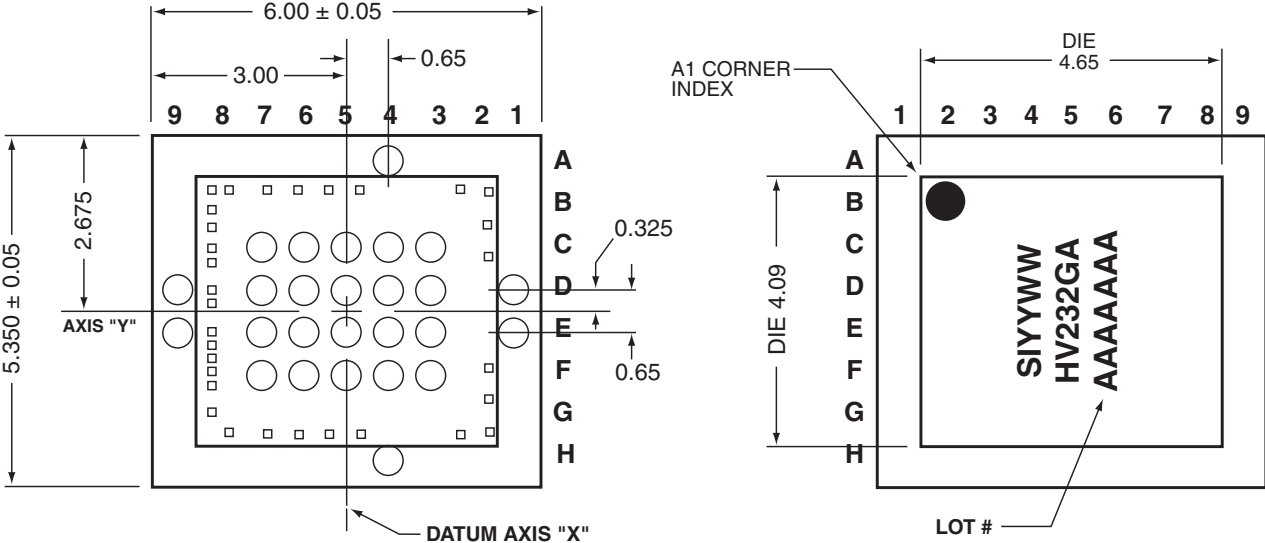

Notes:

- 1. Dimensioning and tolerance per ASME Y14.5M-1994.
- 2. Do not subject part to ultrasonic cleaning or intense UV.
- 3. Contact ball position per JESD 95-1, SPP-010.
- 4. Units are in millimeters.

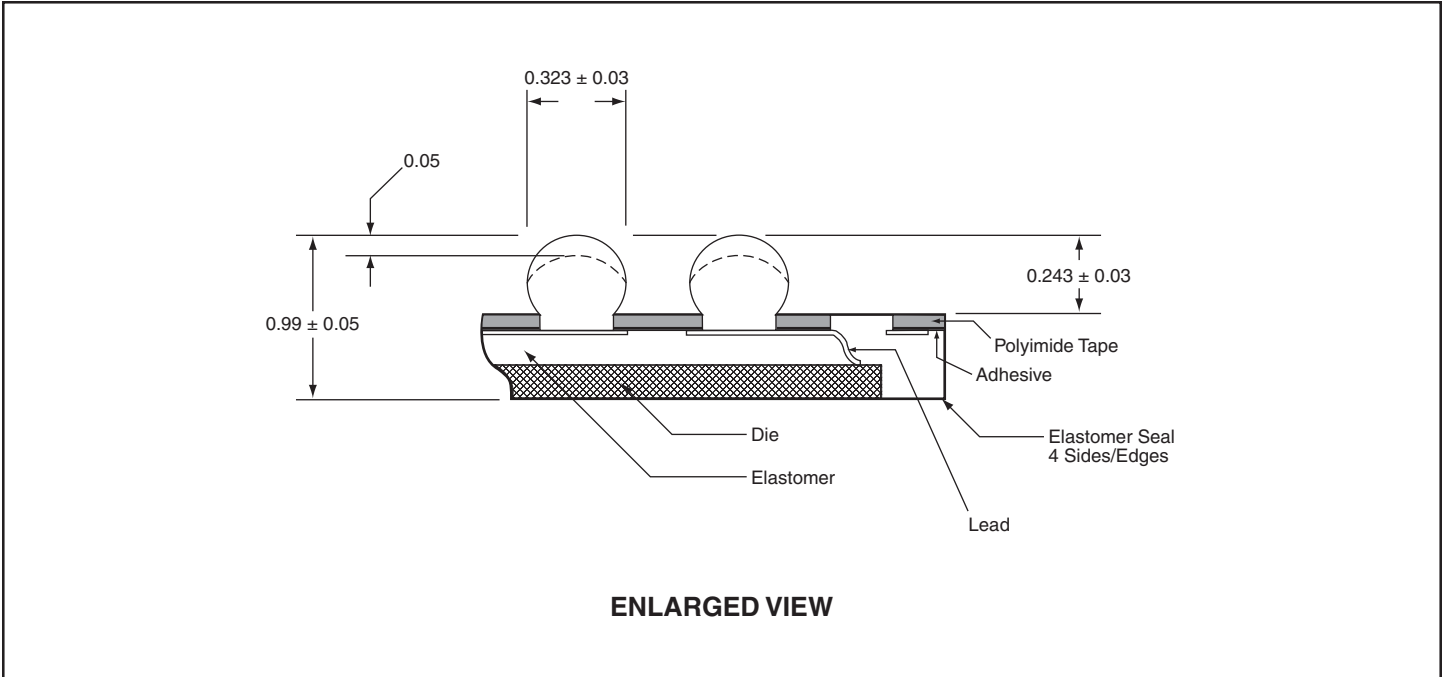

μ-BGA Function Table

Ball Location	Function
A4	SW1
C3	SW2
C4	SW1
C5	SW0
C6	V _{PP}
C7	V _{NN}
D1	SW3
D3	SW3
D4	SW2
D5	SW0
D6	R _{GND}
D7	GND
D9	V _{DD}
E1	SW4
E3	SW4
E4	SW5
E5	SW7
E6	$\overline{\text{LE}}$
E7	CLK
E9	D _{IN}
F3	SW5
F4	SW6
F5	SW7
F6	D _{OUT}
F7	CLR
H4	SW6

Pin Configuration

Pin #	Function	Pin #	Function
1	SW4	14	V _{DD}
2	SW3	15	D _{IN}
3	SW3	16	CLK
4	SW2	17	LE bar
5	SW2	18	CLR
6	SW1	19	D _{OUT}
7	SW1	20	SW7
8	SW0	21	SW7
9	SW0	22	SW6
10	V _{PP}	23	SW6
11	V _{NN}	24	SW5
12	R _{GND}	25	SW5
13	GND	26	SW4

Pad Diagram

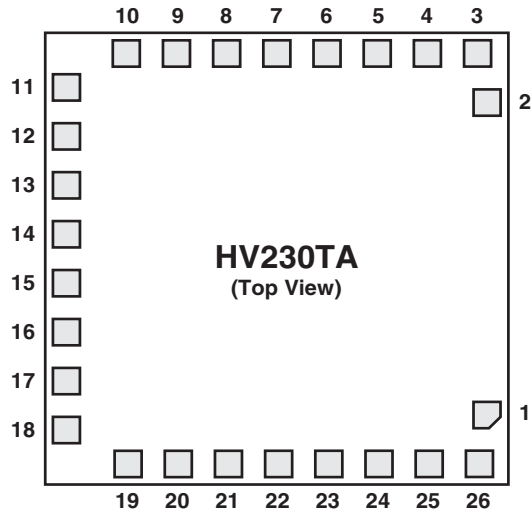

Pad connections are on the backside of the package

Package Dimensions

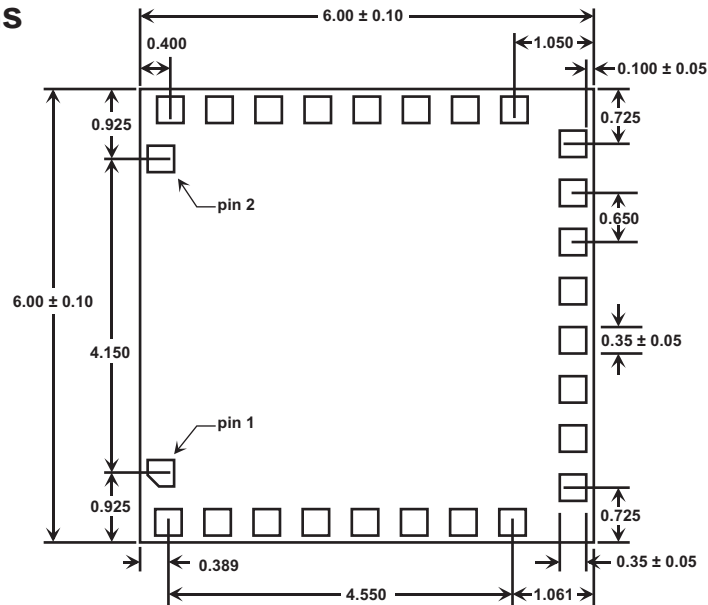

Bottom View
Dimensions are in mm



Side View
Dimensions are in mm

Supertex Inc. does not recommend the use of its products in life support applications and will not knowingly sell its products for use in such applications unless it receives an adequate "products liability indemnification insurance agreement". Supertex does not assume responsibility for use of devices described and limits its liability to the replacement of the devices determined defective due to workmanship. No responsibility is assumed for possible omissions or inaccuracies. Circuitry and specifications are subject to change without notice. For the latest product specifications, refer to the Supertex website: <http://www.supertex.com>. For complete liability information on all Supertex products, refer to the most current databook or to the Legal/ Disclaimer page on the Supertex website.