



CURRENT-MODE PWM CONTROLLER

The KA3842A are fixed frequency current-mode PWM controller. They are specially designed for OFF-Line and DC-to-DC converter applications with minimal external components. These integrated circuits feature a trimmed oscillator for precise duty cycle control, a temperature compensated reference, high gain error amplifier, current sensing comparator, and a high current totempole output ideally suited for driving a power MOSFET.

Protection circuitry includes built under-voltage lockout and current limiting.

The KA3842A, KA3844AM can

The KA3842A have Start-Up Current 0.45 mA

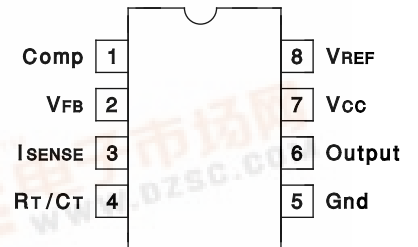

FEATURES

- Low Start-Up Current
- Maximum Duty Cycle
- U/V Lockout With Hysteresis
- Operating Frequency Up To 500kHz

ordering information

Device	Package	Operating temperature
KA3842AM	SO-8	0 to +70°C

BLOCK DIAGRAM

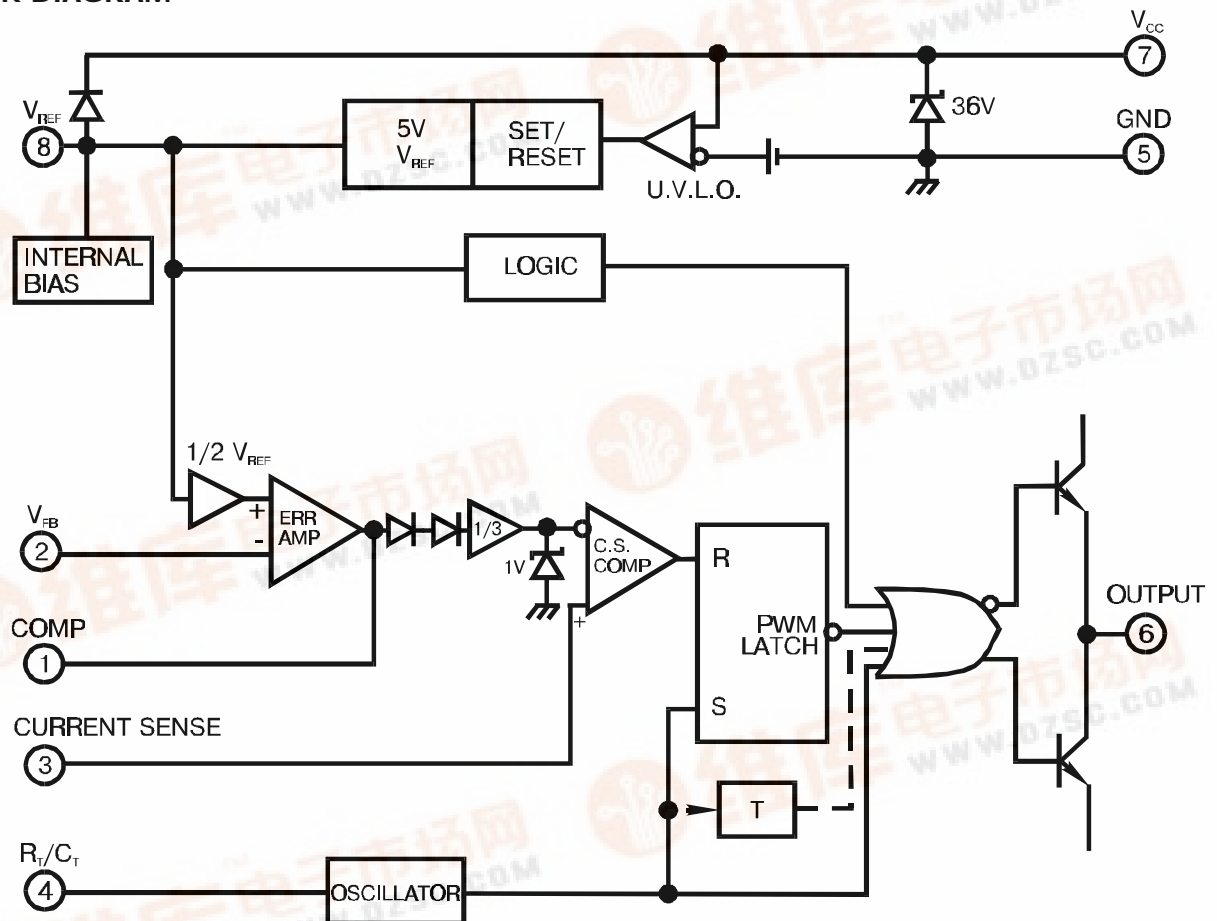

Absolute Maximum Ratings

Characteristic	Symbol	Value	Unit
Supply Voltage	V_{CC}	30	V
Output Current	I_O	± 1	A
Analog Inputs	V_I	-0.3 to V_{CC}	V
Error Amp Output Sink Current	$I_{SINK (E.A)}$	10	mA
Power Dissipation ($T_A=25^\circ C$)	P_O	1	W





Electrical characteristics (* $V_{CC}=15V$, $R_T=10k\Omega$, $C_T=3.3nF$, $T_A=0^{\circ}C$ to $+70^{\circ}C$, unless otherwise specified)

Characteristics	Symbol	Test Condition	Min	Typ	Max	Unit
Reference Section						
Reference Output Voltage	V_{REF}	$T_J = 25^{\circ}C$, $I_{REF} = 1\text{ mA}$	4.9	5.0	5.1	V
Line Regulation	ΔV_{REF}	$12V \leq V_{CC} \leq 25\text{ V}$		6.0	20	mV
Load Regulation	ΔV_{REF}	$1\text{ mA} \leq I_{REF} \leq 20\text{mA}$		6.0	25	
Short Circuit Output Current	I_{SC}	$T_A = 25^{\circ}C$		-100	-180	mA
Oscillator Section						
Oscillation Frequency	f	$T_J = 25^{\circ}C$	47	52	57	KHz
Frequency Change with Voltage	$\Delta f/\Delta V_{CCF}$	$12V \leq V_{CC} \leq 25\text{ V}$		0.05	1.0	%
Oscillator Amplitude	$V_{(OSC)}$			1.6		V_{p-p}
Error Amplifier Section						
Input Bias Current	I_{BIAS}			-0.1	-2	μA
Input Voltage	$V_{I(E.A)}$	$V_1 = 2.5V$	2.42	2.5	2.58	V
Open Loop Voltage Gain	G_{VO}	$2V \leq V_O \leq 4V$	65	90		dB
Power Supply Rejection Ratio	PSRR	$12V \leq V_{CC} \leq 25\text{ V}$	60	70		
Output Sink Current	I_{SINK}	$V_2 = 2.7V$, $V_1 = 1.1V$	2	7		mA
Output Source Current	I_{SOURCE}	$V_2 = 2.3V$, $V_1 = 5V$	-0.5	-1.0		mA
High Output Voltage	V_{OH}	$V_2 = 2.3V$, $R_L = 15K\Omega$ to GND	5.0	6.0		V
Low Output Voltage	V_{OL}	$V_2 = 2.7V$, $R_L = 15K\Omega$ to PIN 8		0.8	1.1	
Current Sense Section						
Gain	G_V	(Note 1 & 2)	2.85	3.0	3.15	V/V
Maximum Input Signal	$V_{I(MAX)}$	$V_1 = 5V$ (Note1)	0.9	1.0	1.1	V
Power Supply Rejection Ratio	PSRR	$12V \leq V_{CC} \leq 25\text{ V}$ (Note 1)		70		dB
Input Bias Current	I_{BIAS}			-3.0	-10	μA
Output Section						
Low Output Voltage	V_{OL}	$I_{SINK} = 20\text{ mA}$		0.08	0.4	V
		$I_{SINK} = 200\text{ mA}$		1.4	2.2	
High Output Voltage	V_{OH}	$I_{SINK} = 20\text{ mA}$	13	13.5		
		$I_{SINK} = 200\text{ mA}$	12	13.0		
Rise Time	t_R	$T_J = 25^{\circ}C$, $C_L = 1nF$ (Note 3)		45	150	nS
Fall Time	t_F	$T_J = 25^{\circ}C$, $C_L = 1nF$ (Note 3)		35	150	
Under-Voltage Lockout Section						
Start Theshold	$V_{TH(ST)}$		14.5	16.0	17.5	V
Min. Operating Voltage (After Turn On)	$V_{OPR(min)}$		8.5	10	11.5	
PWM Section						
Max. Duty Cycle	$D_{(MAX)}$		95	97	100	%
Min. Duty Cycle	$D_{(MAX)}$				0	
Total Standby Current						
Start-Up Current	I_{ST}			0.17	0.3	mA
Operating Supply Current	$I_{CC (OPR)}$	$V_3 = V_2 = 0V$		14	17	
Zener Voltage	V_Z		30	38		V

* Adjust V_{CC} above the start threshold before setting at 15V

Note 1: Parameter measured at trip point of lath with $V_2=0$

Note 2: Gain defined as $A=\Delta V_1/\Delta V_3$; $0 \leq V_3 \leq 0.8V$

Note 3: These parameters, although guaranteed, are not 100% tested in production.



Pad Location

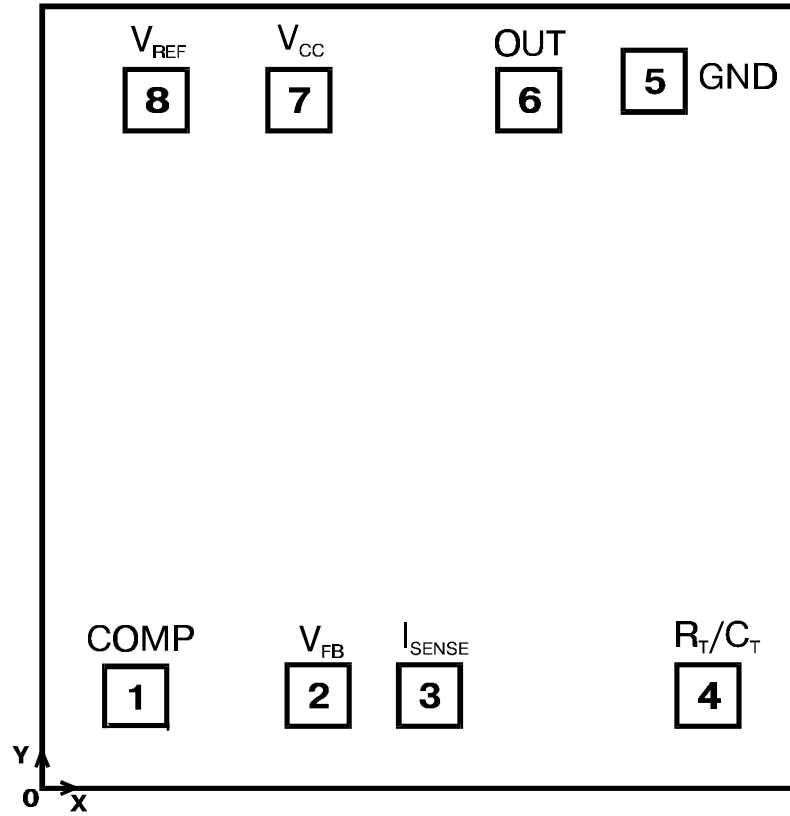

Chip size: 2.38 x 1.63 mm

Pad N	Coordinates μm		Pad N	Coordinates μm	
	X	Y		X	Y
1	90	110	5	1680	1450
2	1050	110	6	1310	1410
3	1310	110			
4	2000	150	7	815	1410
			8	460	1390



DIM.	mm			inch		
	MIN.	TYP.	MAX.	MIN.	TYP.	MAX.
A			1.75			0.069
a1	0.1		0.25	0.004		0.010
a2			1.65			0.065
a3	0.65		0.85	0.026		0.033
b	0.35		0.48	0.014		0.019
b1	0.19		0.25	0.007		0.010
C	0.25		0.5	0.010		0.020
c1	45° (typ.)					
D (1)	4.8		5.0	0.189		0.197
E	5.8		6.2	0.228		0.244
e		1.27			0.050	
e3		3.81			0.150	
F (1)	3.8		4.0	0.15		0.157
L	0.4		1.27	0.016		0.050
M			0.6			0.024
S	8° (max.)					

OUTLINE AND MECHANICAL DATA

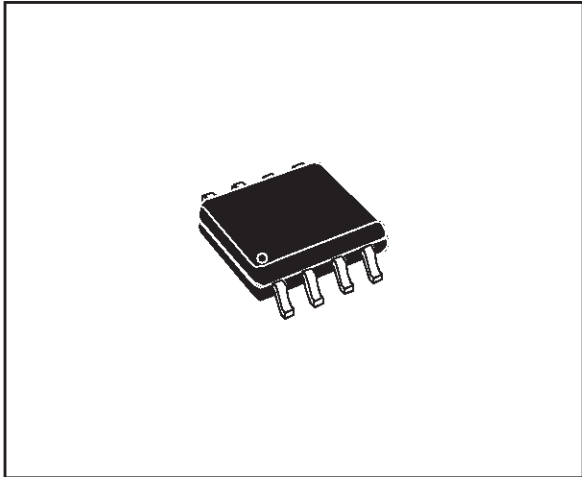

SO8

(1) D and F do not include mold flash or protrusions. Mold flash or protrusions shall not exceed 0.15mm (.006inch).

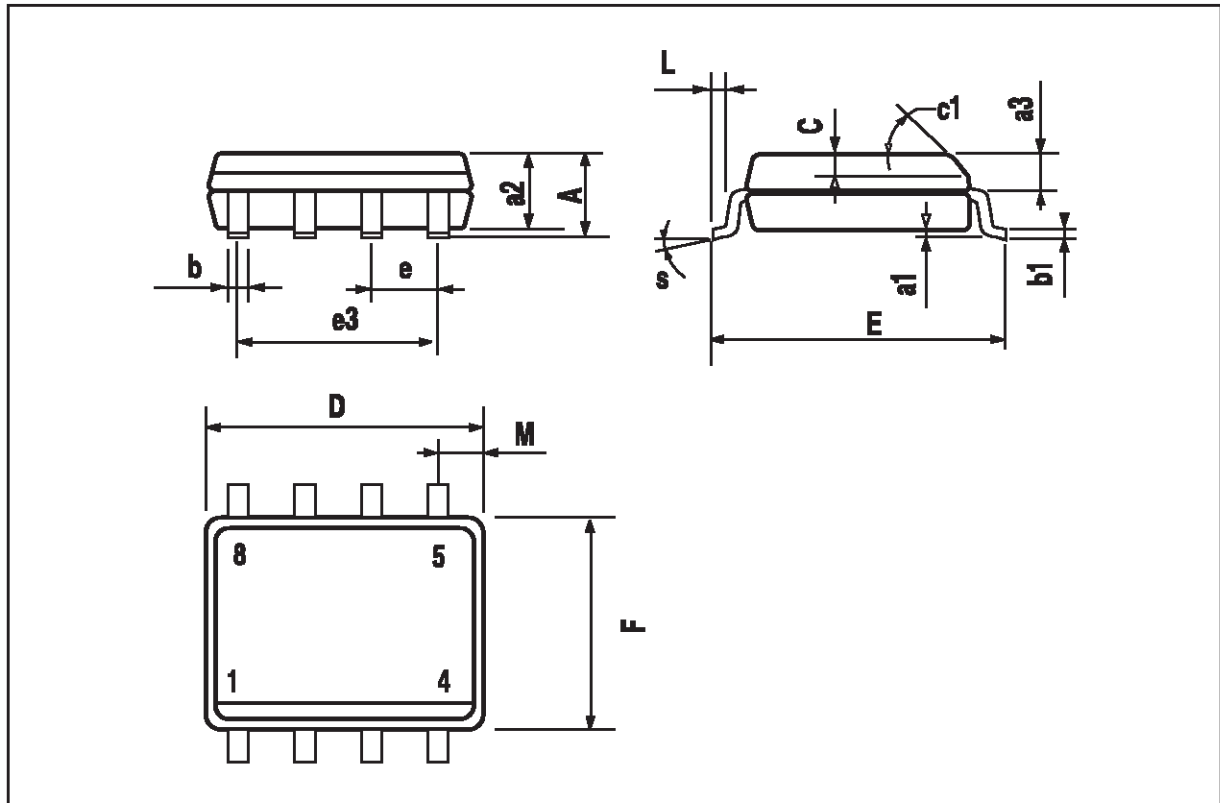

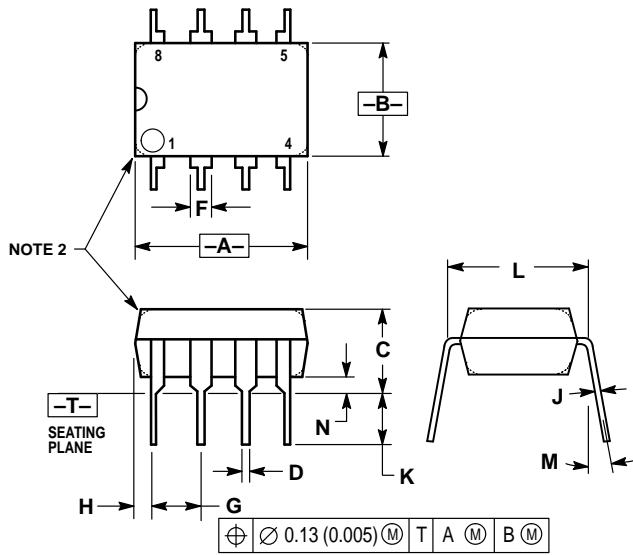

NOTES:

1. DIMENSION L TO CENTER OF LEAD WHEN FORMED PARALLEL.
2. PACKAGE CONTOUR OPTIONAL (ROUND OR SQUARE CORNERS).
3. DIMENSIONING AND TOLERANCING PER ANSI Y14.5M, 1982.

DIM	MILLIMETERS		INCHES	
	MIN	MAX	MIN	MAX
A	9.40	10.16	0.370	0.400
B	6.10	6.60	0.240	0.260
C	3.94	4.45	0.155	0.175
D	0.38	0.51	0.015	0.020
F	1.02	1.78	0.040	0.070
G	2.54 BSC		0.100 BSC	
H	0.76	1.27	0.030	0.050
J	0.20	0.30	0.008	0.012
K	2.92	3.43	0.115	0.135
L	7.62 BSC		0.300 BSC	
M	— 10°		— 10°	
N	0.76	1.01	0.030	0.040