

Monolithic Linear IC

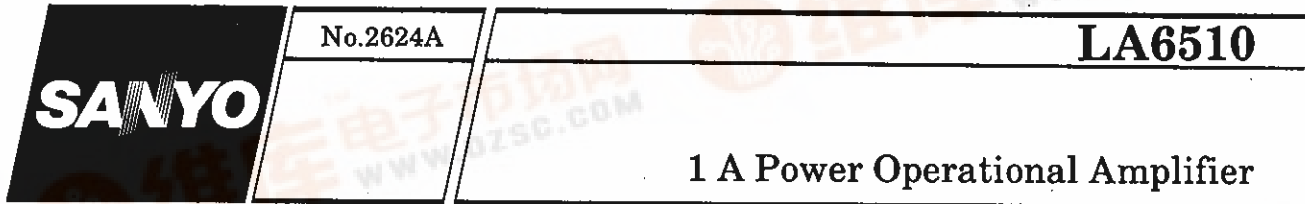

1 A Power Operational Amplifier

OVERVIEW

The LA6510 is a high-performance power operational amplifier IC capable of delivering larger output currents than conventional op amps.

The LA6510 features an on-chip current limiter and provides high voltage gain and a high common-mode rejection ratio.

The LA6510 is an ideal choice for power applications such as DC servos, capstan drivers, actuator drivers, programmable power supplies and high-quality audio amplifiers.

The LA6510 is available in 10-pin SIPs and operates from -15 V and 15 V supplies.

FEATURES

- 1 A output current
- 100 dB voltage gain
- 80 dB common-mode rejection
- 0.15 V/ μ s slew rate
- 2 mV offset voltage
- 10 nA offset current
- On-chip current limiter
- -15 V and 15 V supplies
- 10-pin SIP

PINOUT

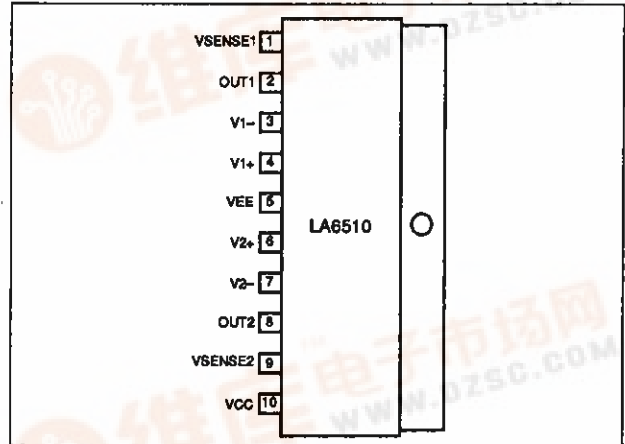

PACKAGE DIMENSIONS

Unit: mm

3064A-SIP10F

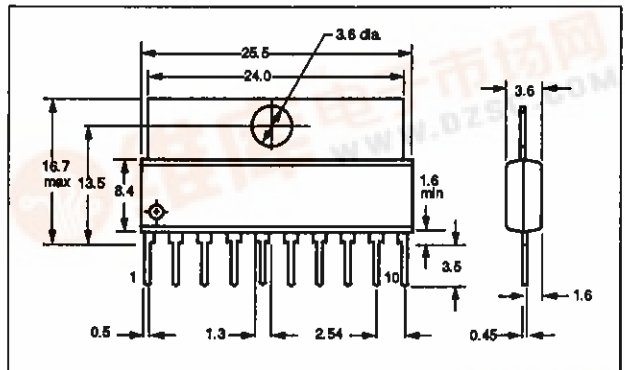

LA6510

BLOCK DIAGRAM

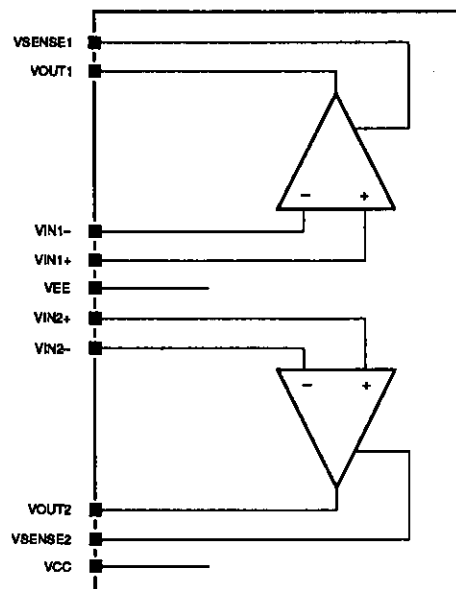

PIN DESCRIPTION

Number	Name	Description
1	VSENSE1	Voltage detect
2	OUT1	Output
3	V1-	Inverting input
4	V1+	Non-inverting input
5	VEE	-15 V supply
6	V2+	Non-inverting input
7	V2-	Inverting input
8	OUT2	Output
9	VSENSE2	Voltage detect
10	VCC	15 V supply

SPECIFICATIONS

Absolute Maximum Ratings

Parameter	Symbol	Rating	Unit
Supply voltages	V _{CC}	18	V
	V _{EE}	-18	
Differential input voltage	V _{ID}	30	V
Common-mode input voltage	V _{ICOM}	±15	V
Output current	I _o	1.0	A
Power dissipation	P _d	2.5	W
Operating temperature range	T _{OPR}	-20 to 75	deg. C
Storage temperature range	T _{STG}	-55 to 150	deg. C

LA6510

Recommended Operating Conditions

$T_a = 25 \text{ deg. C}$

Parameter	Symbol	Rating	Unit
Supply voltages	V_{CC}	15	V
	V_{EE}	-15	

Electrical Characteristics

$V_{CC} = 15 \text{ V}$, $V_{EE} = -15 \text{ V}$, $T_a = 25 \text{ deg. C}$ unless otherwise noted

Parameter	Symbol	Condition	Rating			Unit
			min	typ	max	
Quiescent current	I_{CCO}		-	12	20	mA
Input offset voltage	V_{IO}	$R_g \leq 10 \text{ k}\Omega$	-	2	6	mV
Input offset current	I_{IO}		-	10	200	nA
Input bias current	I_b		-	100	700	nA
Common-mode input voltage	V_{ICM}		-15	-	13	V
Common-mode rejection ratio	CMR		70	80	-	dB
Maximum output voltage	V_O	$R_L = 33 \Omega$	± 12	± 13	-	V
Voltage gain	V_{G_O}		-	100	-	dB
Slew rate	SR	$G_V = 0$, $R_L = 33 \Omega$, $R = 2.2 \Omega$, $L = 0.1 \mu\text{F}$	-	0.15	-	V/ μs
Equivalent input noise voltage	V_{NI}	$R_g = 1 \text{ k}\Omega$, DIN AUDIO	-	2	-	μV
Supply voltage rejection ratio	SVR		-	30	150	$\mu\text{V/V}$
Limiting current	I_{SC}	$R_{SC} = 2.2 \Omega$	-	0.35	-	A

Typical Performance Characteristics

TYPICAL APPLICATION

Power dissipation vs. ambient temperature

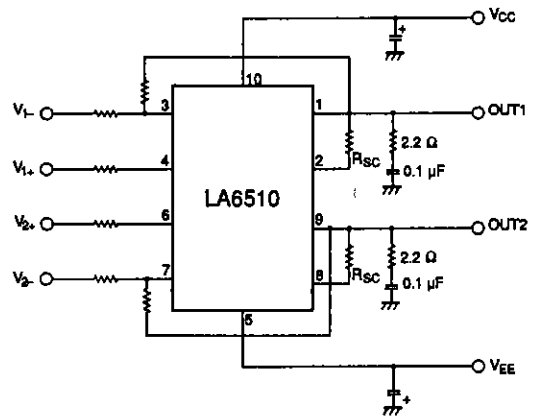
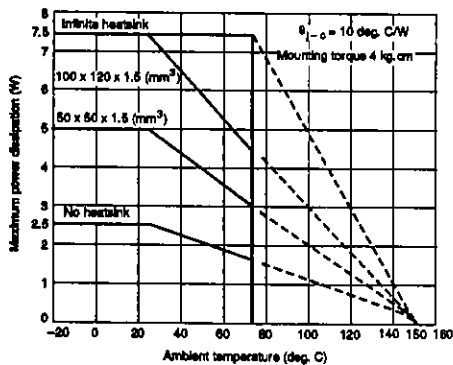

- No products described or contained herein are intended for use in surgical implants, life-support systems, aerospace equipment, nuclear power control systems, vehicles, disaster/crime-prevention equipment and the like, the failure of which may directly or indirectly cause injury, death or property loss.
- Anyone purchasing any products described or contained herein for an above-mentioned use shall:
 - ① Accept full responsibility and indemnify and defend SANYO ELECTRIC CO., LTD., its affiliates, subsidiaries and distributors and all their officers and employees, jointly and severally, against any and all claims and litigation and all damages, cost and expenses associated with such use:
 - ② Not impose any responsibility for any fault or negligence which may be cited in any such claim or litigation on SANYO ELECTRIC CO., LTD., its affiliates, subsidiaries and distributors or any of their officers and employees jointly or severally.
- Information (including circuit diagrams and circuit parameters) herein is for example only; it is not guaranteed for volume production. SANYO believes information herein is accurate and reliable, but no guarantees are made or implied regarding its use or any infringements of intellectual property rights or other rights of third parties.