

**SANYO**

**Vertical Deflection Output Circuit**

**Overview**

The LA7840 is a vertical deflection output IC for TVs and CRT displays with excellent image quality that use a BUS control system signal processing IC. This IC can drive the direct (even including a DC component) deflection yoke with the sawtooth wave output from the BUS control system signal processing IC. When used in conjunction with Sanyo's LA7615 series of BUS control system signal processing ICs for TVs, this IC can process all color television signal system functions through the BUS system. Because the maximum deflection current is 1.8 Ap-p, the LA7840 is suited for small and medium screen sets.

**Features**

- Low power dissipation due to built-in pump-up circuit
- Vertical output circuit
- Thermal protection circuit built in
- Excellent crossover characteristics
- DC coupling possible

**Specifications**

**Maximum Ratings at Ta = 25 °C**

Parameter	Symbol	Conditions	Ratings	Unit
Maximum supply voltage	V <sub>CC6</sub> max		34	V
Output block supply voltage	V <sub>CC3</sub> max		70	V
Deflection output current	I <sub>2</sub> max		-1.5 to +1.5	Ap-o
Thermal resistance	θ <sub>j-c</sub>		4.0	°C/W
Allowable power dissipation	P <sub>d</sub> max	With arbitrarily large heat sink	9	W
Operating temperature	T <sub>opr</sub>		-20 to +85	°C
Storage temperature	T <sub>stg</sub>		-40 to +150	°C

**Operating Conditions at Ta = 25 °C**

Parameter	Symbol	Conditions	Ratings	Unit
Recommended supply voltage	V <sub>CC6</sub>		24	V
Operating supply voltage range	V <sub>CC6</sub> op		16 to 33	V
Recommended deflection output current	I <sub>2</sub> p-p		to 1.8	Ap-p

**Package Dimensions**

unit : mm

**3075-SIP7H**

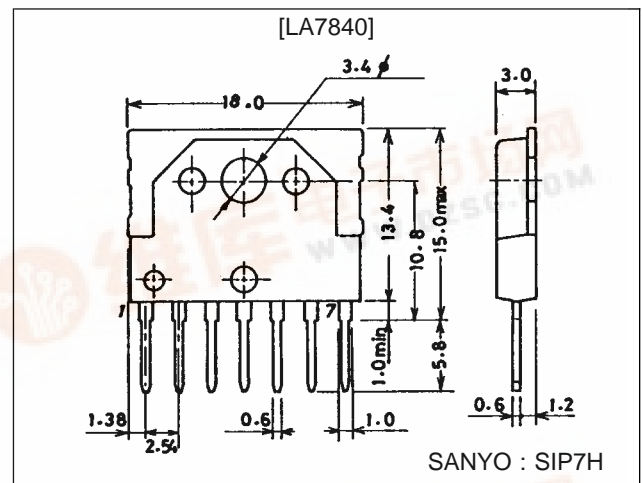

## LA7840

### Operating Characteristics at $T_a = 25\text{ }^\circ\text{C}$ , $V_{CC6} = 24\text{ V}$

Parameter	Symbol	Conditions	min	typ	max	Unit
Pump-up charge saturation voltage	$V_{S7-1}$	$I_7 = 20\text{ mA}$			1.8	V
Pump-up discharge saturation voltage	$V_{S6-7}$	$I_7 = -0.9\text{ A}$			3.0	V
Deflection output saturation voltage (lower)	$V_{S2-1}$	$I_2 = 0.9\text{ A}$			1.3	V
Deflection output saturation voltage (upper)	$V_{S3-2}$	$I_2 = -0.9\text{ A}$			3.2	V
Idling current	$I_{DL}$		35		65	mA
Midpoint voltage	$V_{MID}$		11.0	12.0	13.0	V

### Block Diagram

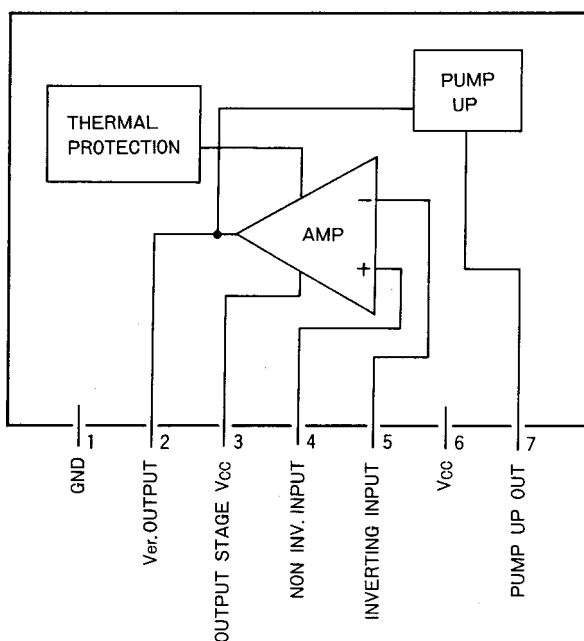

### Sample Application Circuit

(Single power supply)

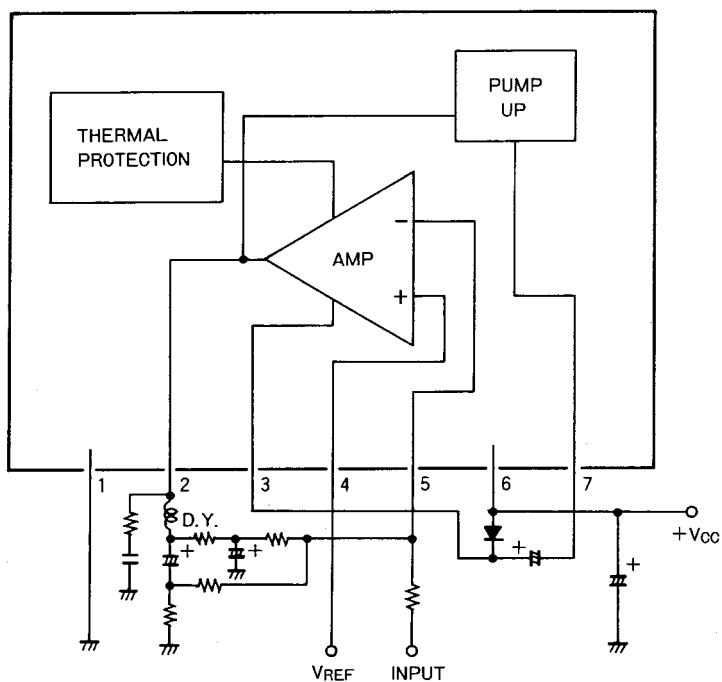

# LA7840

## Sample Application Circuit

(Double power supply)

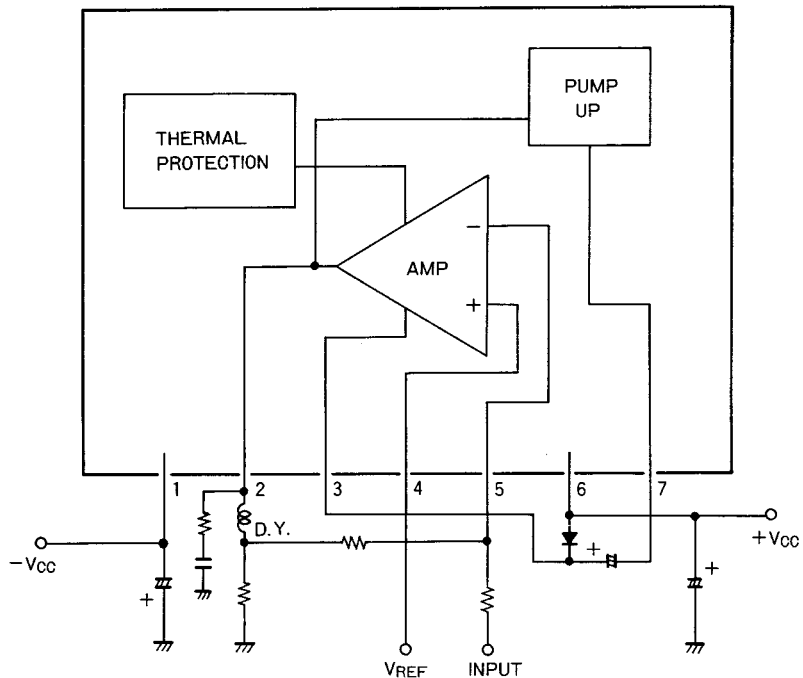

## Sample Application Circuit

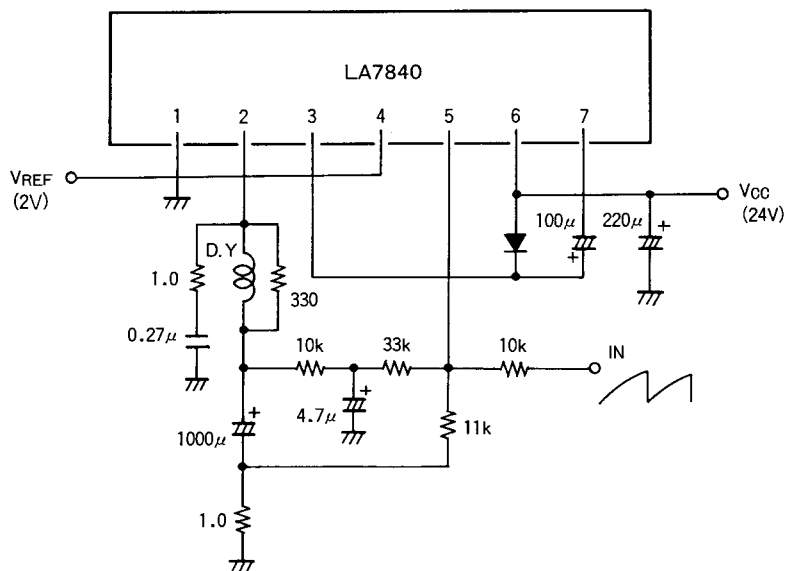

Unit (resistance:  $\Omega$ , capacitance: F)

- No products described or contained herein are intended for use in surgical implants, life-support systems, aerospace equipment, nuclear power control systems, vehicles, disaster/crime-prevention equipment and the like, the failure of which may directly or indirectly cause injury, death or property loss.
- Anyone purchasing any products described or contained herein for an above-mentioned use shall:
  - ① Accept full responsibility and indemnify and defend SANYO ELECTRIC CO., LTD., its affiliates, subsidiaries and distributors and all their officers and employees, jointly and severally, against any and all claims and litigation and all damages, cost and expenses associated with such use:
  - ② Not impose any responsibility for any fault or negligence which may be cited in any such claim or litigation on SANYO ELECTRIC CO., LTD., its affiliates, subsidiaries and distributors or any of their officers and employees jointly or severally.
- Information (including circuit diagrams and circuit parameters) herein is for example only; it is not guaranteed for volume production. SANYO believes information herein is accurate and reliable, but no guarantees are made or implied regarding its use or any infringements of intellectual property rights or other rights of third parties.