

## Voltage comparator

## LM111/211/311/ LM311B

### DESCRIPTION

The LM111 series are voltage comparators that have input currents approximately a hundred times lower than devices like the  $\mu$ A710. They are designed to operate over a wider range of supply voltages; from standard  $\pm 15\text{V}$  op amp supplies down to a single 3V supply. Their output is compatible with RTL, DTL, and TTL as well as MOS circuits. Further, they can drive lamps or relays, switching voltages up to 50V at currents as high as 50mA.

Both the inputs and the outputs of the LM111 series can be isolated from system ground, and the output can drive loads referred to ground, the positive supply, or the negative supply. Offset balancing and strobe capability are provided and outputs can be wire-ORed.

Although slower than the  $\mu$ A710 (200ns response time vs 40ns), the devices are also much less prone to spurious oscillations. The LM111 series has the same pin configuration as the  $\mu$ A710 series.

### FEATURES

- Operates from single 3V supply (LM311B)
- Maximum input bias current: 150nA (LM311—250nA)
- Maximum offset current: 20nA (LM311—50nA)
- Differential input voltage range:  $\pm 30\text{V}$
- Power consumption: 135mW at  $\pm 15\text{V}$
- High sensitivity—200V/mV
- Zero crossing detector

### ORDERING INFORMATION

DESCRIPTION	TEMPERATURE RANGE	ORDER CODE	DWG #
8-Pin Plastic Dual In-Line Package (DIP)	-55°C to +125°C	LM111N	0404B
8-Pin Plastic Dual In-Line Package (DIP)	-25°C to +85°C	LM211N	0404B
8-Pin Plastic Small Outline Package (SO)	0 to +70°C	LM311D	0174C
8-Pin Plastic Dual In-Line Package (DIP)	0 to +70°C	LM311N	0404B
8-Pin Plastic Small Outline Package (SO)	-25°C to +85°C	LM211D	0174C
8-Pin Ceramic Dual In-Line Package (CERDIP)	-55°C to +125°C	LM111FE	0580A
8-Pin Plastic Small Outline Package (SO)	0 to +70°C	LM311BD	0174C
8-Pin Plastic Dual In-Line Package (DIP)	0 to +70°C	LM311BN	0404B

### PIN CONFIGURATION

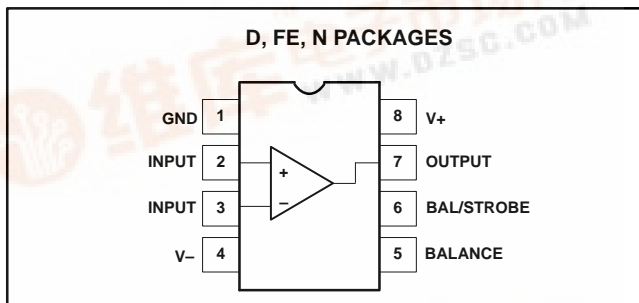

### APPLICATIONS

- Precision squarer
- Positive/negative peak detector
- Low voltage adjustable reference supply
- Switching power amplifier

# Voltage comparator

## LM111/211/311/ LM311B

### EQUIVALENT SCHEMATIC

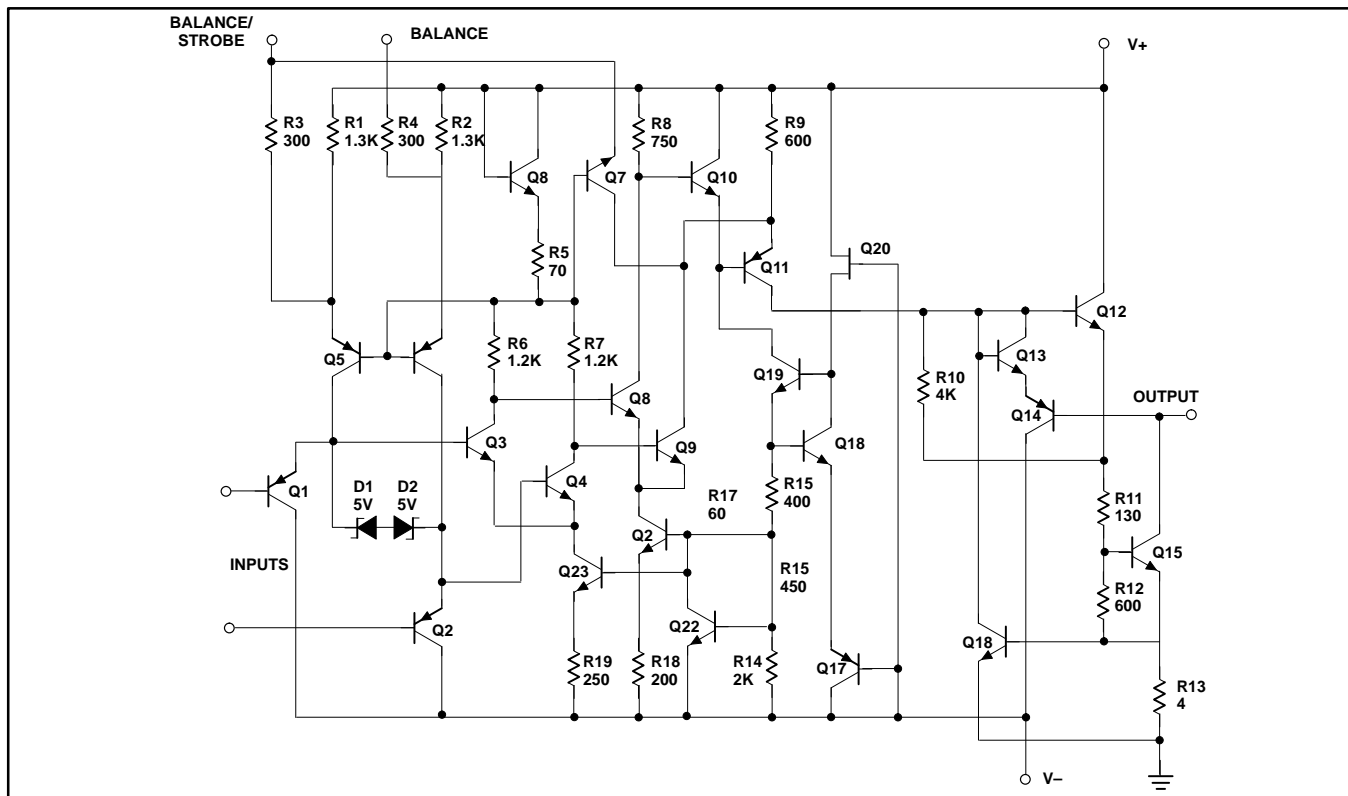

### ABSOLUTE MAXIMUM RATINGS

SYMBOL	PARAMETER	RATING	UNIT
V <sub>S</sub>	Total supply voltage	36	V
	Output to negative supply voltage:		
	LM111/LM211	50	V
	LM311/LM311B	40	V
	Ground to negative supply voltage	30	V
	Differential input voltage	±30	V
V <sub>IN</sub>	Input voltage <sup>1</sup>	±15	V
P <sub>D MAX</sub>	Maximum power dissipation, T <sub>A</sub> =25°C (still-air) <sup>2</sup>		
	F package	810	mW
	N package	1190	mW
	D package	780	mW
I	Output short-circuit duration	10	sec
T <sub>A</sub>	Operating ambient temperature range		
	LM111	-55 to +125	°C
	LM211	-25 to +85	°C
	LM311/LM311B	0 to +70	°C
T <sub>STG</sub>	Storage temperature range	-65 to +150	°C
T <sub>SOLD</sub>	Lead soldering temperature (10sec max)	300	°C

**NOTES:**

1. This rating applies for ±15V supplies. The positive input voltage limit is 30V above the negative supply. The negative input voltage limit is equal to the negative supply voltage or 30V below the positive supply, whichever is less.
2. Derate above 25°C, at the following rates: F package at 6.4mW/°C; N package at 9.5mW/°C; D package at 6.2mW/°C

## Voltage comparator

LM111/211/311/  
LM311B**DC ELECTRICAL CHARACTERISTICS<sup>1, 2, 3, 6</sup>**

Over temperature range unless otherwise specified.

SYMBOL	PARAMETER	TEST CONDITIONS	LM111/LM211			LM311			LM311B			UNIT
			Min	Typ	Max	Min	Typ	Max	Min	Typ	Max	
V <sub>OS</sub>	Input offset voltage <sup>3</sup>	T <sub>A</sub> =25°C, R <sub>S</sub> ≤50kΩ		0.7	3.0		2.0	7.5		2.0	7.5	mV
I <sub>OS</sub>	Input offset current <sup>3</sup>	T <sub>A</sub> =25°C		4.0	10		6.0	50		6	25	nA
I <sub>BIAS</sub>	Input bias current	T <sub>A</sub> =25°C		60	100		100	250		100	200	nA
A <sub>V</sub>	Voltage gain	T <sub>A</sub> =25°C		200			200			200		V/mV
	Response time <sup>4</sup>	T <sub>A</sub> =25°C		200			200			500		ns
V <sub>SAT</sub>	Saturation voltage	LM111/211 V <sub>IN</sub> ≤-5mV, I <sub>OUT</sub> =50mA LM311/B V <sub>IN</sub> ≤-10mV, I <sub>OUT</sub> =50mA T <sub>A</sub> =25°C		0.75	1.5		0.75	1.5		0.75	1.5	V
I <sub>BAL/STR</sub>	Strobe on current	T <sub>A</sub> =25°C		3.0			3.0			3.0		mA
I <sub>LEAKAGE</sub>	Output leakage current <sup>6</sup>	LM111/211 V <sub>IN</sub> ≥5mV, V <sub>OUT</sub> =35V LM311/B V <sub>IN</sub> ≥10mV, V <sub>OUT</sub> =35V T <sub>A</sub> =25°C, I <sub>STROBE</sub> =3mA (V <sub>-</sub> = V <sub>GND</sub> = -5V)		0.2	10		0.2	50		0.2	50	nA
V <sub>OS</sub>	Input offset voltage <sup>3</sup>	R <sub>S</sub> ≤50kΩ			4.0			10			10	mV
I <sub>OS</sub>	Input offset current <sup>3</sup>				20			70			50	nA
I <sub>BIAS</sub>	Input bias current				150			300			250	nA
V <sub>IN</sub>	Input voltage range	V=±15V (Pin 7 may go to 5V)	-14.5	13.8 to -14.7	13.0	-14.5	13.8 to -14.7	13.0	V- +0.5		V+ -1.5	V
V <sub>OL</sub>	Saturation voltage <sup>6</sup>	V <sub>+</sub> ≥ 4.5V, V <sub>-</sub> = 0 LM111/211 V <sub>IN</sub> ≤-6mV, I <sub>SINK</sub> ≤8mA LM311/B V <sub>IN</sub> ≤-10mV, I <sub>SINK</sub> ≤8mA		0.23	0.4		0.23	0.4		0.23	0.4	V
I <sub>OH</sub>	Output leakage current	V <sub>IN</sub> ≥5mV, V <sub>OUT</sub> =35V		0.1	0.5							μA
I <sub>CC</sub>	Positive supply current	T <sub>A</sub> =25°C		5.1	6.0		5.1	7.5		1.6	3.5	mA
I <sub>EE</sub>	Negative supply voltage	T <sub>A</sub> =25°C		4.1	5.0		4.1	5.0				mA

**NOTES:**

1. This rating applies for ±15V supplies. The positive input voltage limit is 30V above the negative supply. The negative input voltage limit is equal to the negative supply voltage or 30V below the positive supply, whichever is less.
2. These specifications apply for V<sub>S</sub>=±15V and 0°C < T<sub>A</sub> < 70°C unless otherwise specified. With the LM211, however, all temperature specifications are limited to -25°C ≤ T<sub>A</sub> ≤ 85°C and for the LM111 is limited to -55°C T<sub>A</sub> < 125°C. The offset voltage, offset current, and bias current specifications apply for any supply voltage from a single 5V supply up to ±15V supplies.
3. The offset voltages and offset currents given are the maximum values required to drive the output within a volt of either supply with 1mA load. Thus, these parameters define an error band and take into account the worst case effects of voltage gain and input impedance.
4. The response time specified is for a 100mV input step with 5mV over-drive.
5. Do not short the strobe pin to ground; it should be current driven at 3mA to 5mA.
6. LM311B, all parameters are at V<sub>+</sub> = 3V ±10%, V<sub>-</sub> = GND = 0V.

# Voltage comparator

## LM111/211/311/ LM311B

### TYPICAL APPLICATIONS

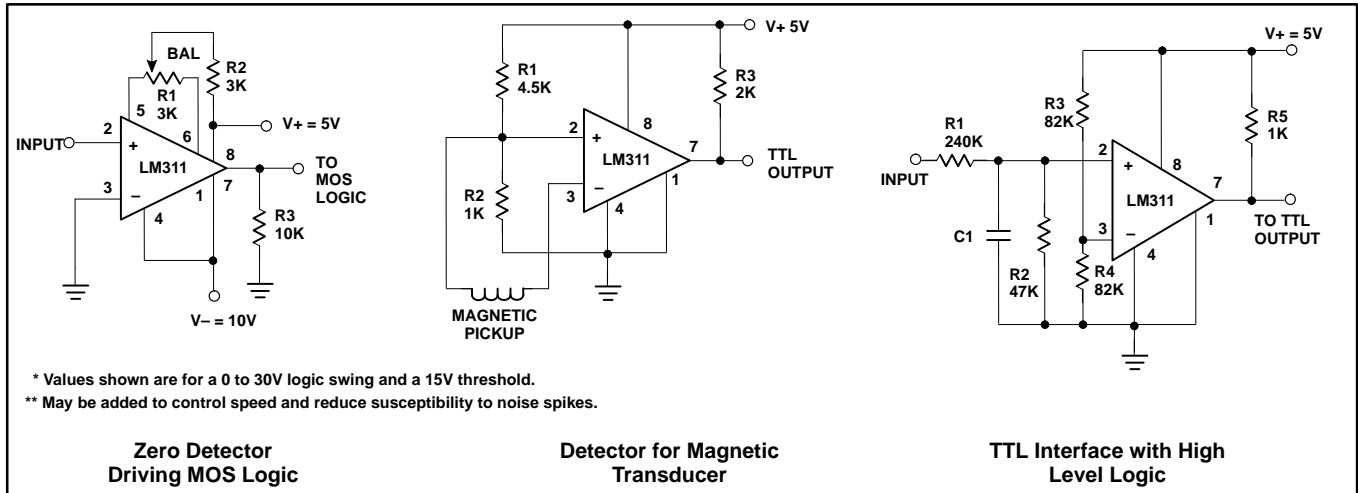

**Zero Detector  
Driving MOS Logic**

**Detector for Magnetic  
Transducer**

**TTL Interface with High  
Level Logic**