



June 1999

LM231A/LM231/LM331A/LM331 Precision Voltage-to-Frequency Converters

General Description

The LM231/LM331 family of voltage-to-frequency converters are ideally suited for use in simple low-cost circuits for analog-to-digital conversion, precision frequency-to-voltage conversion, long-term integration, linear frequency modulation or demodulation, and many other functions. The output when used as a voltage-to-frequency converter is a pulse train at a frequency precisely proportional to the applied input voltage. Thus, it provides all the inherent advantages of the voltage-to-frequency conversion techniques, and is easy to apply in all standard voltage-to-frequency converter applications. Further, the LM231A/LM331A attain a new high level of accuracy versus temperature which could only be attained with expensive voltage-to-frequency modules. Additionally the LM231/331 are ideally suited for use in digital systems at low power supply voltages and can provide low-cost analog-to-digital conversion in microprocessor-controlled systems. And, the frequency from a battery powered voltage-to-frequency converter can be easily channeled through a simple photoisolator to provide isolation against high common mode levels.

The LM231/LM331 utilize a new temperature-compensated band-gap reference circuit, to provide excellent accuracy

over the full operating temperature range, at power supplies as low as 4.0V. The precision timer circuit has low bias currents without degrading the quick response necessary for 100 kHz voltage-to-frequency conversion. And the output are capable of driving 3 TTL loads, or a high voltage output up to 40V, yet is short-circuit-proof against V_{CC} .

Features

- Guaranteed linearity 0.01% max
- Improved performance in existing voltage-to-frequency conversion applications
- Split or single supply operation
- Operates on single 5V supply
- Pulse output compatible with all logic forms
- Excellent temperature stability, ± 50 ppm/ $^{\circ}\text{C}$ max
- Low power dissipation, 15 mW typical at 5V
- Wide dynamic range, 100 dB min at 10 kHz full scale frequency
- Wide range of full scale frequency, 1 Hz to 100 kHz
- Low cost

Typical Applications

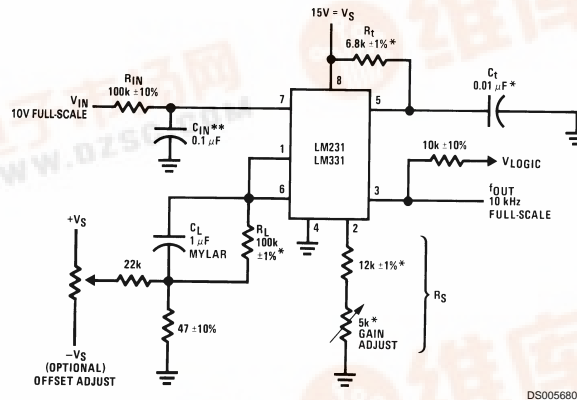

$$f_{OUT} = \frac{V_{IN}}{2.09 \text{ V}} \cdot \frac{R_S}{R_L} \cdot \frac{1}{R_1 C_1}$$

*Use stable components with low temperature coefficients. See Typical Applications section.

**0.1 μF or 1 μF , See "Principles of Operation."

FIGURE 1. Simple Stand-Alone Voltage-to-Frequency Converter with $\pm 0.03\%$ Typical Linearity ($f = 10 \text{ Hz}$ to 11 kHz)

Teflon[®] is a registered trademark of DuPont



Absolute Maximum Ratings (Note 1)

If Military/Aerospace specified devices are required, please contact the National Semiconductor Sales Office/Distributors for availability and specifications.

	LM231A/LM231	LM331A/LM331
Supply Voltage	40V	40V
Output Short Circuit to Ground	Continuous	Continuous
Output Short Circuit to V_{CC}	Continuous	Continuous
Input Voltage	-0.2V to $+V_S$	-0.2V to $+V_S$
Operating Ambient Temperature Range	T_{MIN} T_{MAX} -25°C to +85°C	T_{MIN} T_{MAX} 0°C to +70°C
Power Dissipation (P_D at 25°C) and Thermal Resistance (θ_{jA}) (N Package) P_D θ_{jA}	1.25W 100°C/W	1.25W 100°C/W
Lead Temperature (Soldering, 10 sec.) Dual-In-Line Package (Plastic)	260°C	260°C
ESD Susceptibility (Note 4) N Package	500V	500V

Electrical Characteristics

$T_A=25^\circ\text{C}$ unless otherwise specified (Note 2)

Parameter	Conditions	Min	Typ	Max	Units
VFC Non-Linearity (Note 3)	$4.5V \leq V_S \leq 20V$		± 0.003	± 0.01	% Full-Scale
	$T_{MIN} \leq T_A \leq T_{MAX}$		± 0.006	± 0.02	% Full-Scale
VFC Non-Linearity In Circuit of Figure 1	$V_S = 15V$, $f = 10\text{ Hz to }11\text{ kHz}$		± 0.024	± 0.14	% Full-Scale
Conversion Accuracy Scale Factor (Gain) LM231, LM231A LM331, LM331A	$V_{IN} = -10V$, $R_S = 14\text{ k}\Omega$	0.95	1.00	1.05	kHz/V
		0.90	1.00	1.10	kHz/V
Temperature Stability of Gain LM231/LM331 LM231A/LM331A	$T_{MIN} \leq T_A \leq T_{MAX}$, $4.5V \leq V_S \leq 20V$		± 30	± 150	ppm/°C
			± 20	± 50	ppm/°C
Change of Gain with V_S	$4.5V \leq V_S \leq 10V$		0.01	0.1	%/V
	$10V \leq V_S \leq 40V$		0.006	0.06	%/V
Rated Full-Scale Frequency	$V_{IN} = -10V$	10.0			kHz
Gain Stability vs Time (1000 Hrs)	$T_{MIN} \leq T_A \leq T_{MAX}$		± 0.02		% Full-Scale
Overrange (Beyond Full-Scale) Frequency	$V_{IN} = -11V$	10			%
INPUT COMPARATOR					
Offset Voltage LM231/LM331 LM231A/LM331A	$T_{MIN} \leq T_A \leq T_{MAX}$ $T_{MIN} \leq T_A \leq T_{MAX}$		± 3	± 10	mV
			± 4	± 14	mV
Bias Current			-80	-300	nA
Offset Current			± 8	± 100	nA
Common-Mode Range	$T_{MIN} \leq T_A \leq T_{MAX}$	-0.2		$V_{CC}-2.0$	V
TIMER					
Timer Threshold Voltage, Pin 5		0.63	0.667	0.70	$\times V_S$
Input Bias Current, Pin 5 All Devices LM231/LM331 LM231A/LM331A	$V_S = 15V$ $0V \leq V_{PIN 5} \leq 9.9V$ $V_{PIN 5} = 10V$ $V_{PIN 5} = 10V$		± 10	± 100	nA
			200	1000	nA
			200	500	nA

Electrical Characteristics (Continued)

$T_A=25^{\circ}\text{C}$ unless otherwise specified (Note 2)

Parameter	Conditions	Min	Typ	Max	Units
TIMER					
$V_{SAT\ PIN\ 5}$ (Reset)	$I = 5\text{ mA}$		0.22	0.5	V
CURRENT SOURCE (Pin 1)					
Output Current LM231, LM231A LM331, LM331A	$R_S=14\text{ k}\Omega$, $V_{PIN\ 1}=0$	126 116	135 136	144 156	μA μA
Change with Voltage	$0\text{V} \leq V_{PIN\ 1} \leq 10\text{V}$		0.2	1.0	μA
Current Source OFF Leakage LM231, LM231A, LM331, LM331A All Devices	$T_A=T_{MAX}$		0.02 2.0	10.0 50.0	nA nA
Operating Range of Current (Typical)			(10 to 500)		μA
REFERENCE VOLTAGE (Pin 2)					
LM231, LM231A LM331, LM331A		1.76 1.70	1.89 1.89	2.02 2.08	V_{DC} V_{DC}
Stability vs Temperature			± 60		ppm/ $^{\circ}\text{C}$
Stability vs Time, 1000 Hours			± 0.1		%
LOGIC OUTPUT (Pin 3)					
V_{SAT}	$I=5\text{ mA}$ $I=3.2\text{ mA}$ (2 TTL Loads), $T_{MIN} \leq T_A \leq T_{MAX}$		0.15 0.10	0.50 0.40	V V
OFF Leakage			± 0.05	1.0	μA
SUPPLY CURRENT					
LM231, LM231A LM331, LM331A	$V_S=5\text{V}$ $V_S=40\text{V}$ $V_S=5\text{V}$ $V_S=40\text{V}$	2.0 2.5 1.5 2.0	3.0 4.0 3.0 4.0	4.0 6.0 6.0 8.0	mA mA mA mA

Note 1: Absolute Maximum Ratings indicate limits beyond which damage to the device may occur. DC and AC electrical specifications do not apply when operating the device beyond its specified operating conditions.

Note 2: All specifications apply in the circuit of Figure 4, with $4.0\text{V} \leq V_S \leq 40\text{V}$, unless otherwise noted.

Note 3: Nonlinearity is defined as the deviation of f_{OUT} from $V_{IN} \times (10\text{ kHz} \sim 10\text{ V}_{DC})$ when the circuit has been trimmed for zero error at 10 Hz and at 10 kHz, over the frequency range 1 Hz to 11 kHz. For the timing capacitor, C_T , use NPO ceramic, Teflon[®], or polystyrene.

Note 4: Human body model, 100 pF discharged through a 1.5 k Ω resistor.

Functional Block Diagram

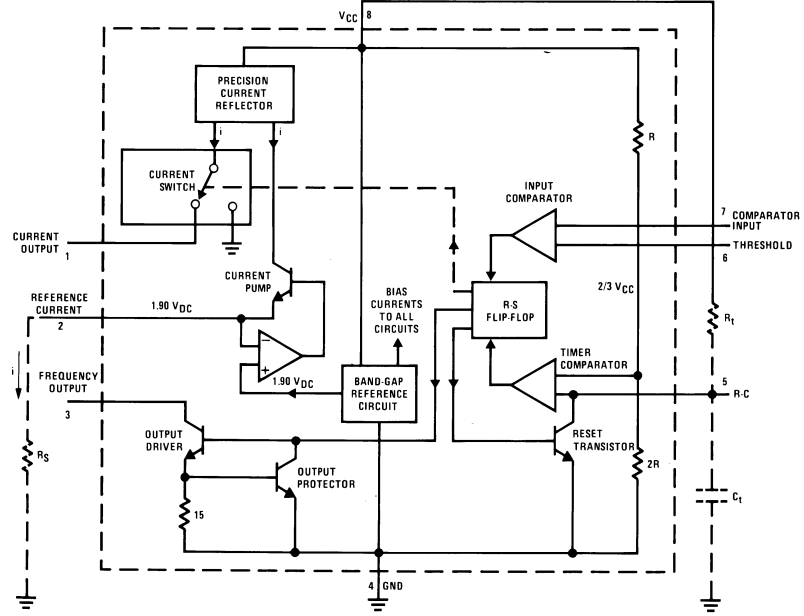

DS005680-2

Pin numbers apply to 8-pin packages only.

FIGURE 2.

Typical Performance Characteristics

(All electrical characteristics apply for the circuit of Figure 4, unless otherwise noted.)

Nonlinearity Error as Precision V-to-F Converter (Figure 4)

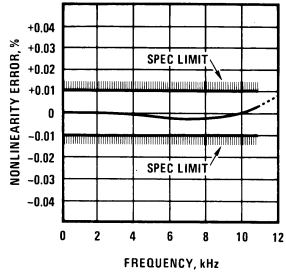

Nonlinearity Error

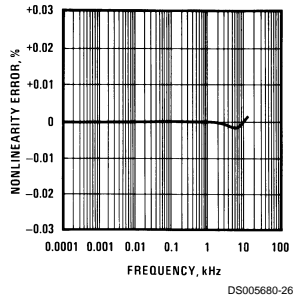

Nonlinearity Error vs Power Supply Voltage

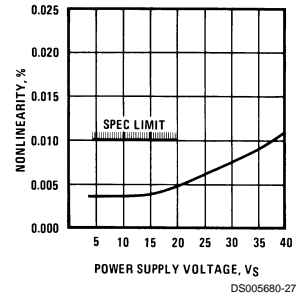

Frequency vs Temperature

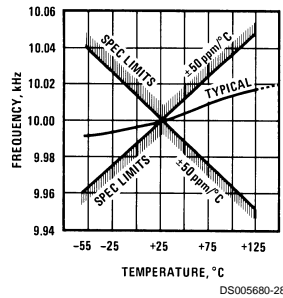

V_{REF} vs Temperature

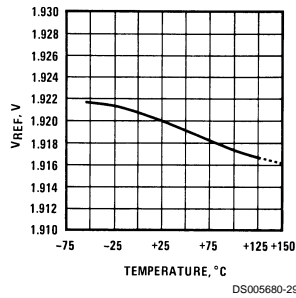

Output Frequency vs V_{SUPPLY}

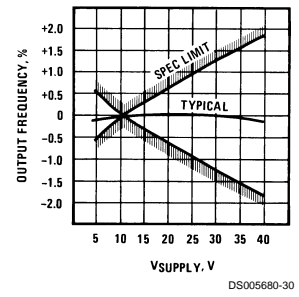

100 kHz Nonlinearity Error (Figure 5)

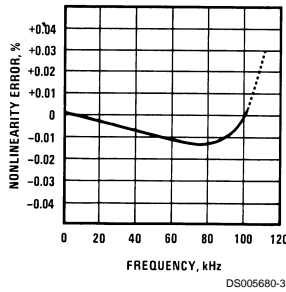

Nonlinearity Error (Figure 1)

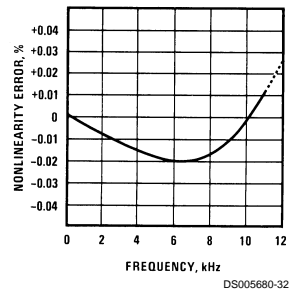

Input Current (Pins 6,7) vs Temperature

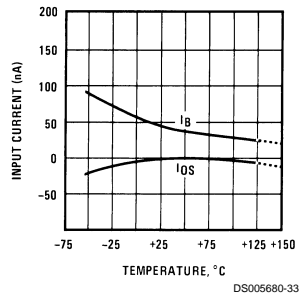

Typical Performance Characteristics (Continued)

Power Drain vs V_{SUPPLY}

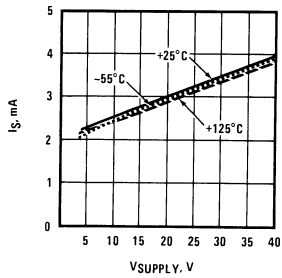

DS005680-34

Output Saturation Voltage vs I_{OUT} (Pin 3)

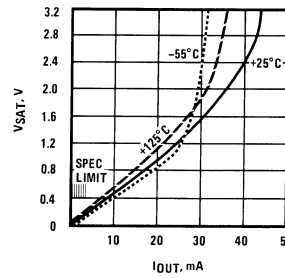

DS005680-35

Nonlinearity Error, Precision F-to-V Converter (Figure 7)

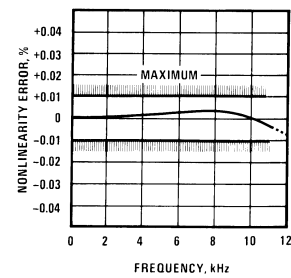

DS005680-36

Typical Applications

PRINCIPLES OF OPERATION OF A SIMPLIFIED VOLTAGE-TO-FREQUENCY CONVERTER

The LM231/331 are monolithic circuits designed for accuracy and versatile operation when applied as voltage-to-frequency (V-to-F) converters or as frequency-to-voltage (F-to-V) converters. A simplified block diagram of the LM231/331 is shown in Figure 3 and consists of a switched current source, input comparator, and 1-shot timer.

The operation of these blocks is best understood by going through the operating cycle of the basic V-to-F converter, Figure 3, which consists of the simplified block diagram of the LM231/331 and the various resistors and capacitors connected to it.

The voltage comparator compares a positive input voltage, V_1 , at pin 7 to the voltage, V_x , at pin 6. If V_1 is greater, the comparator will trigger the 1-shot timer. The output of the timer will turn ON both the frequency output transistor and the switched current source for a period $t = 1.1 R_t C_t$. During this period, the current i will flow out of the switched current source and provide a fixed amount of charge, $Q = i \times t$, into the capacitor, C_L . This will normally charge V_x up to a higher level than V_1 . At the end of the timing period, the current i will turn OFF, and the timer will reset itself.

Now there is no current flowing from pin 1, and the capacitor C_L will be gradually discharged by R_L until V_x falls to the level of V_1 . Then the comparator will trigger the timer and start another cycle.

The current flowing into C_L is exactly $I_{AVE} = i \times (1.1 \times R_t C_t) \times f$, and the current flowing out of C_L is exactly $V_x / R_L \cong V_{IN} / R_L$. If V_{IN} is doubled, the frequency will double to maintain this balance. Even a simple V-to-F converter can provide a frequency precisely proportional to its input voltage over a wide range of frequencies.

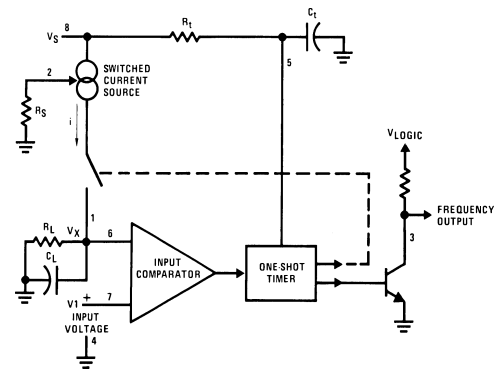

DS005680-4

FIGURE 3. Simplified Block Diagram of Stand-Alone Voltage-to-Frequency Converter and External Components

DETAIL OF OPERATION, FUNCTIONAL BLOCK DIAGRAM (Figure 2)

The block diagram shows a band gap reference which provides a stable 1.9 V_{DC} output. This 1.9 V_{DC} is well regulated over a V_S range of 3.9V to 40V. It also has a flat, low temperature coefficient, and typically changes less than 1/2% over a 100°C temperature change.

The current pump circuit forces the voltage at pin 2 to be at 1.9V, and causes a current $i = 1.90V / R_S$ to flow. For $R_S = 14k$, $i = 135 \mu A$. The precision current reflector provides a current equal to i to the current switch. The current switch switches the current to pin 1 or to ground depending on the state of the R_S flip-flop.

The timing function consists of an R_S flip-flop, and a timer comparator connected to the external $R_t C_t$ network. When the input comparator detects a voltage at pin 7 higher than pin 6, it sets the R_S flip-flop which turns ON the current switch and the output driver transistor. When the voltage at pin 5 rises to 2/3 V_{CC} , the timer comparator causes the R_S flip-flop to reset. The reset transistor is then turned ON and the current switch is turned OFF.

However, if the input comparator still detects pin 7 higher than pin 6 when pin 5 crosses 2/3 V_{CC} , the flip-flop will not be reset, and the current at pin 1 will continue to flow, in its attempt to make the voltage at pin 6 higher than pin 7. This

Typical Applications (Continued)

condition will usually apply under start-up conditions or in the case of an overload voltage at signal input. It should be noted that during this sort of overload, the output frequency will be 0; as soon as the signal is restored to the working range, the output frequency will be resumed.

The output driver transistor acts to saturate pin 3 with an ON resistance of about 50Ω . In case of overvoltage, the output current is actively limited to less than 50 mA.

The voltage at pin 2 is regulated at $1.90 V_{DC}$ for all values of i between $10\ \mu A$ to $500\ \mu A$. It can be used as a voltage reference for other components, but care must be taken to ensure that current is not taken from it which could reduce the accuracy of the converter.

PRINCIPLES OF OPERATION OF BASIC VOLTAGE-TO-FREQUENCY CONVERTER (Figure 1)

The simple stand-alone V-to-F converter shown in Figure 1 includes all the basic circuitry of Figure 3 plus a few components for improved performance.

A resistor, $R_{IN}=100\ k\Omega\pm 10\%$, has been added in the path to pin 7, so that the bias current at pin 7 ($-80\ nA$ typical) will cancel the effect of the bias current at pin 6 and help provide minimum frequency offset.

The resistance R_S at pin 2 is made up of a $12\ k\Omega$ fixed resistor plus a $5\ k\Omega$ (cermet, preferably) gain adjust rheostat. The function of this adjustment is to trim out the gain tolerance of the LM231/331, and the tolerance of R_i , R_L and C_t .

For best results, all the components should be stable low-temperature-coefficient components, such as metal-film resistors. The capacitor should have low dielectric absorption; depending on the temperature characteristics desired, NPO ceramic, polystyrene, Teflon or polypropylene are best suited.

A capacitor C_{IN} is added from pin 7 to ground to act as a filter for V_{IN} . A value of $0.01\ \mu F$ to $0.1\ \mu F$ will be adequate in most cases; however, in cases where better filtering is required, a

$1\ \mu F$ capacitor can be used. When the RC time constants are matched at pin 6 and pin 7, a voltage step at V_{IN} will cause a step change in f_{OUT} . If C_{IN} is much less than C_L , a step at V_{IN} may cause f_{OUT} to stop momentarily.

A 47Ω resistor, in series with the $1\ \mu F\ C_L$, is added to give hysteresis effect which helps the input comparator provide the excellent linearity (0.03% typical).

DETAIL OF OPERATION OF PRECISION V-TO-F CONVERTER (Figure 4)

In this circuit, integration is performed by using a conventional operational amplifier and feedback capacitor, C_F . When the integrator's output crosses the nominal threshold level at pin 6 of the LM231/331, the timing cycle is initiated.

The average current fed into the op amp's summing point (pin 2) is $i \times (1.1 R_i C_t) \times f$ which is perfectly balanced with $-V_{IN}/R_{IN}$. In this circuit, the voltage offset of the LM231/331 input comparator does not affect the offset or accuracy of the V-to-F converter as it does in the stand-alone V-to-F converter; nor does the LM231/331 bias current or offset current. Instead, the offset voltage and offset current of the operational amplifier are the only limits on how small the signal can be accurately converted. Since op amps with voltage offset well below $1\ mV$ and offset currents well below $2\ nA$ are available at low cost, this circuit is recommended for best accuracy for small signals. This circuit also responds immediately to any change of input signal (which a stand-alone circuit does not) so that the output frequency will be an accurate representation of V_{IN} , as quickly as 2 output pulses' spacing can be measured.

In the precision mode, excellent linearity is obtained because the current source (pin 1) is always at ground potential and that voltage does not vary with V_{IN} or f_{OUT} . (In the stand-alone V-to-F converter, a major cause of non-linearity is the output impedance at pin 1 which causes i to change as a function of V_{IN}).

The circuit of Figure 5 operates in the same way as Figure 4, but with the necessary changes for high speed operation.

Typical Applications (Continued)

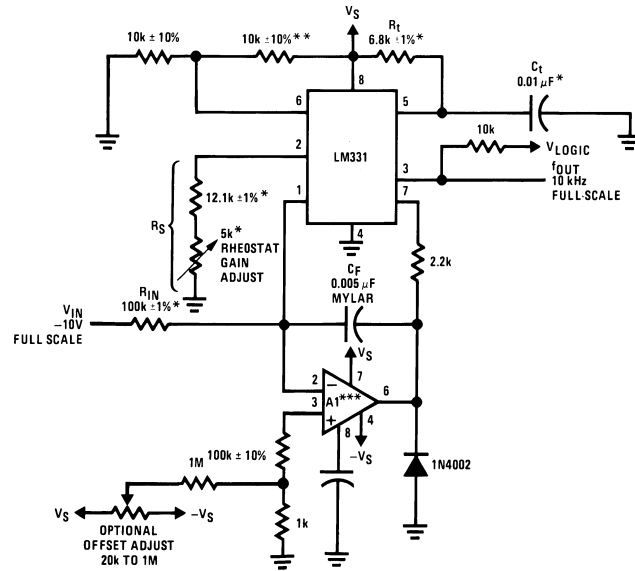

DS005680-5

$$f_{\text{OUT}} = \frac{-V_{\text{IN}}}{2.09 \text{ V}} \cdot \frac{R_S}{R_{\text{IN}}} \cdot \frac{1}{R_{\text{T}} C_{\text{T}}}$$

*Use stable components with low temperature coefficients. See Typical Applications section.

**This resistor can be 5 kΩ or 10 kΩ for $V_S=8\text{V}$ to 22V, but must be 10 kΩ for $V_S=4.5\text{V}$ to 8V.

***Use low offset voltage and low offset current op amps for A1: recommended type LF411A

FIGURE 4. Standard Test Circuit and Applications Circuit, Precision Voltage-to-Frequency Converter

Typical Applications (Continued)

DETAILS OF OPERATION, FREQUENCY-TO-VOLTAGE CONVERTERS (Figure 6 and Figure 7)

In these applications, a pulse input at f_{IN} is differentiated by a C-R network and the negative-going edge at pin 6 causes the input comparator to trigger the timer circuit. Just as with a V-to-F converter, the average current flowing out of pin 1 is $I_{AVERAGE} = i \times (1.1 R_t C_t) \times f$.

In the simple circuit of Figure 6, this current is filtered in the network $R_t = 100 \text{ k}\Omega$ and $1 \mu\text{F}$. The ripple will be less than 10 mV peak, but the response will be slow, with a 0.1 second time constant, and settling of 0.7 second to 0.1% accuracy.

In the precision circuit, an operational amplifier provides a buffered output and also acts as a 2-pole filter. The ripple will be less than 5 mV peak for all frequencies above 1 kHz, and the response time will be much quicker than in Figure 6. However, for input frequencies below 200 Hz, this circuit will have worse ripple than Figure 6. The engineering of the filter time-constants to get adequate response and small enough ripple simply requires a study of the compromises to be made. Inherently, V-to-F converter response can be fast, but F-to-V response can not.

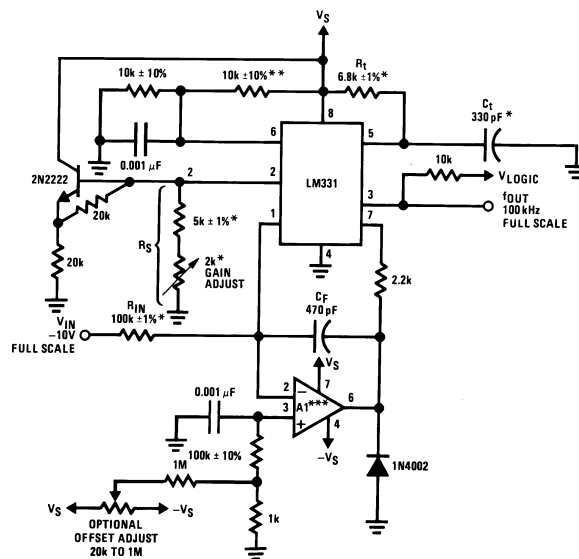

DS005680-6

*Use stable components with low temperature coefficients.
See Typical Applications section.

**This resistor can be 5 k Ω or 10 k Ω for $V_S=8\text{V}$ to 22V, but must be 10 k Ω for $V_S=4.5\text{V}$ to 8V.

***Use low offset voltage and low offset current op amps for A1: recommended types LF411A or LF356.

**FIGURE 5. Precision Voltage-to-Frequency Converter,
100 kHz Full-Scale, $\pm 0.03\%$ Non-Linearity**

Typical Applications (Continued)

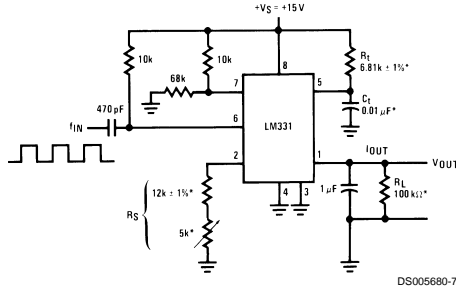

DS005680-7

$$V_{OUT} = f_{IN} \times 2.09V \times \frac{R_1}{R_5} \times (R_1 C_1)$$

*Use stable components with low temperature coefficients.

FIGURE 6. Simple Frequency-to-Voltage Converter, 10 kHz Full-Scale, ±0.06% Non-Linearity

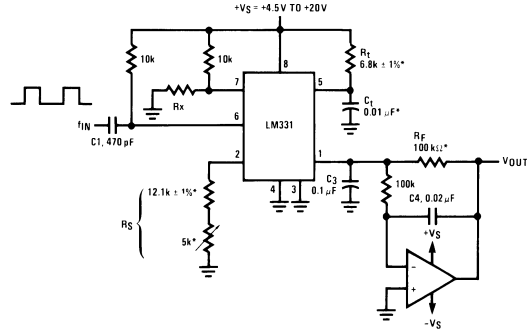

DS005680-8

$$V_{OUT} = -f_{IN} \times 2.09V \times \frac{R_6}{R_8} \times (R_1 C_1)$$

$$\text{SELECT } R_x = \frac{(V_S - 2V)}{0.2 \text{ mA}}$$

*Use stable components with low temperature coefficients.

FIGURE 7. Precision Frequency-to-Voltage Converter, 10 kHz Full-Scale with 2-Pole Filter, ±0.01% Non-Linearity Maximum

Light Intensity to Frequency Converter

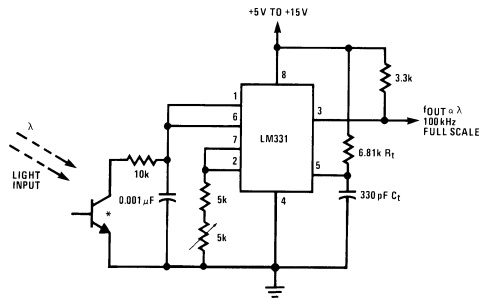

DS005680-9

*L14F-1, L14G-1 or L14H-1, photo transistor (General Electric Co.) or similar

Temperature to Frequency Converter

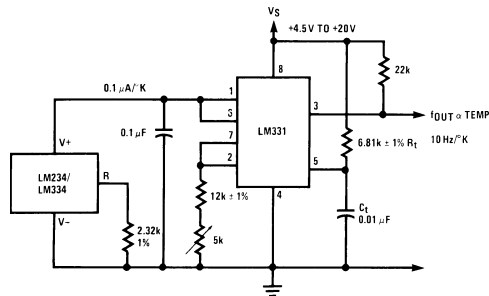

DS005680-10

Typical Applications (Continued)

Long-Term Digital Integrator Using VFC

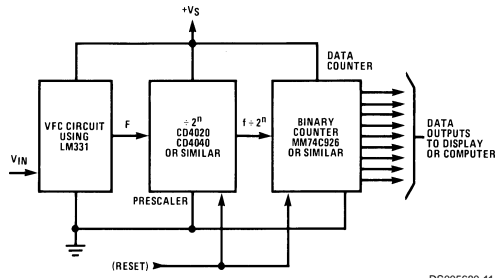

DS005680-11

Basic Analog-to-Digital Converter Using Voltage-to-Frequency Converter

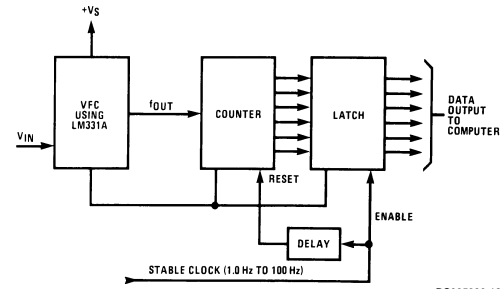

DS005680-12

Analog-to-Digital Converter with Microprocessor

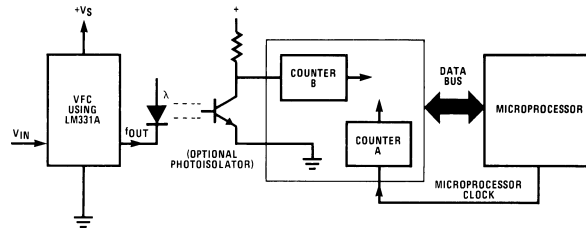

DS005680-13

Remote Voltage-to-Frequency Converter with 2-Wire Transmitter and Receiver

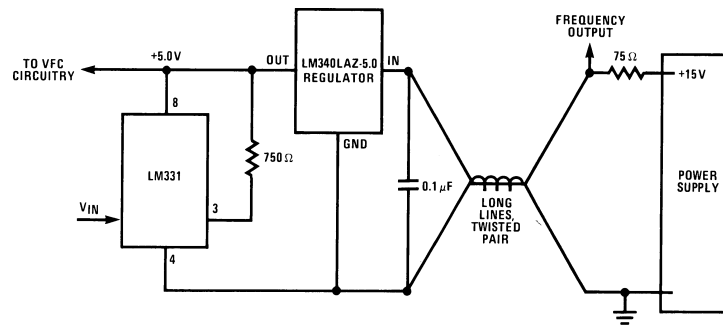

DS005680-14

Typical Applications (Continued)

Voltage-to-Frequency Converter with Square-Wave Output Using $\div 2$ Flip-Flop

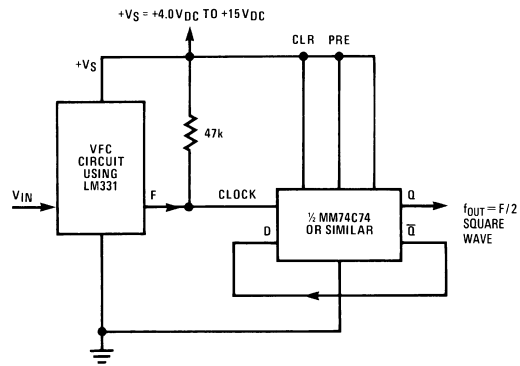

DS005680-15

Voltage-to-Frequency Converter with Isolators

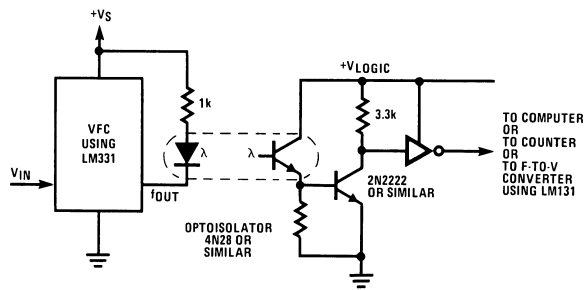

DS005680-16

Voltage-to-Frequency Converter with Isolators

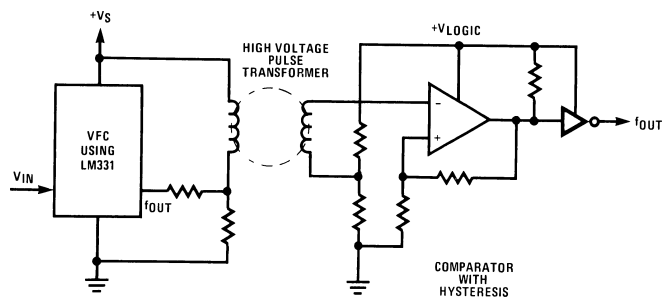

DS005680-17

Typical Applications (Continued)

Voltage-to-Frequency Converter with Isolators

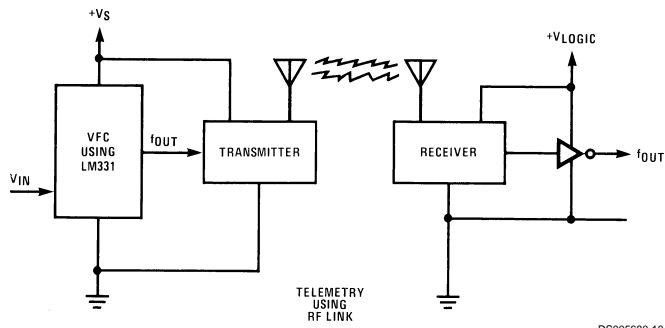

Voltage-to-Frequency Converter with Isolators

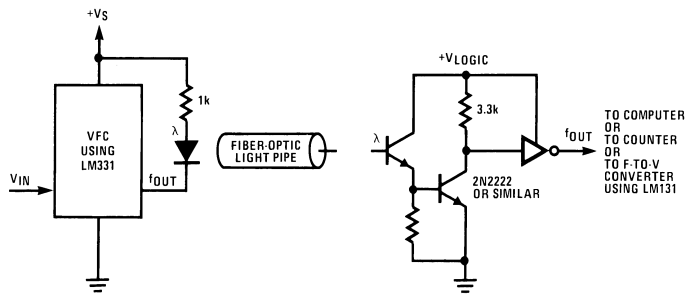

Connection Diagram

Dual-In-Line Package

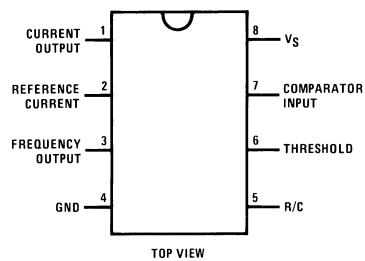

Order Number LM231AN, LM231N, LM331AN,
or LM331N
See NS Package Number N08E

Schematic Diagram

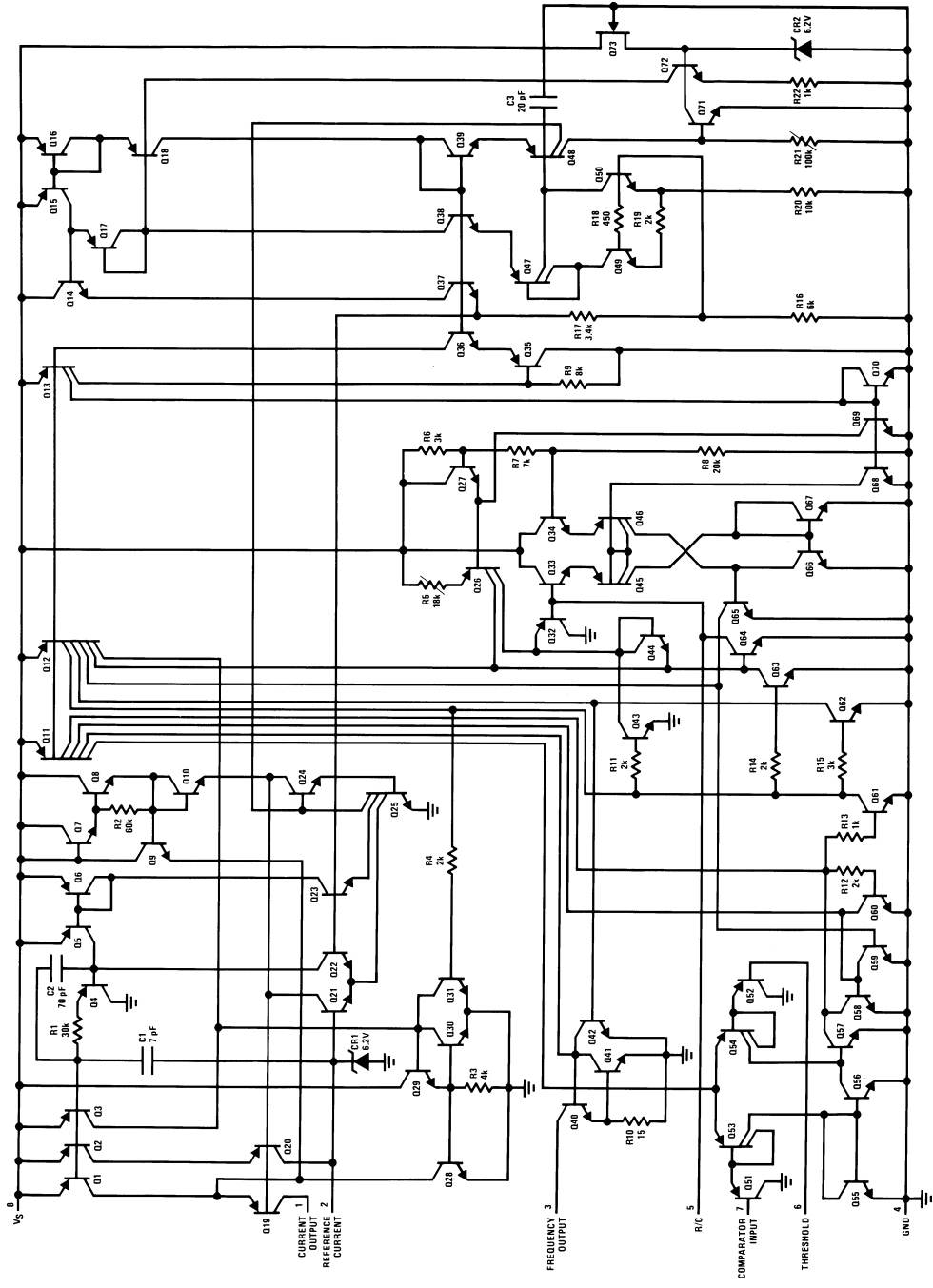

DS90C680-22

Physical Dimensions inches (millimeters) unless otherwise noted

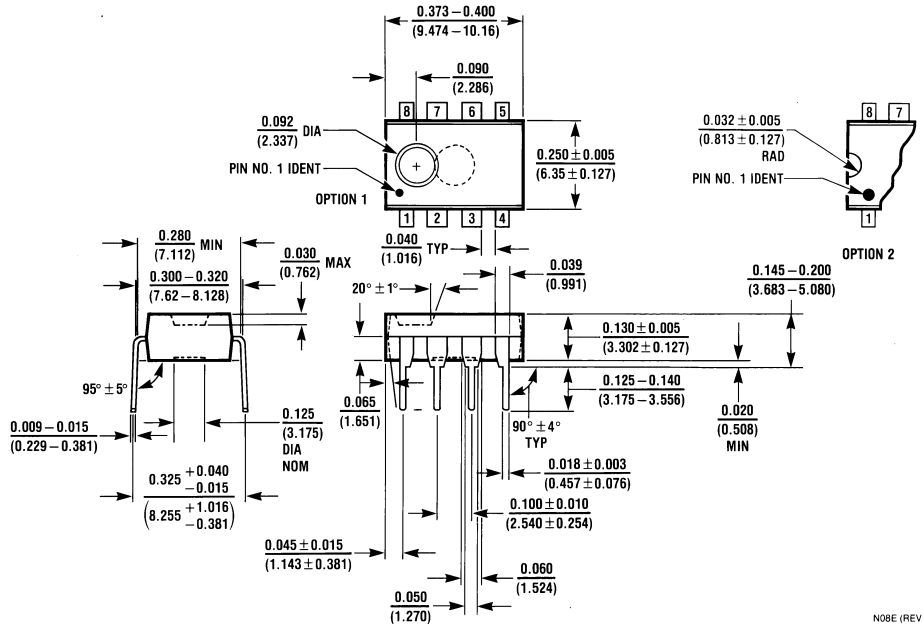

Dual-In-Line Package (N)
Order Number LM231AN, LM231N, LM331AN, or LM331N
NS Package N08E

N08E (REV F)

LIFE SUPPORT POLICY

NATIONAL'S PRODUCTS ARE NOT AUTHORIZED FOR USE AS CRITICAL COMPONENTS IN LIFE SUPPORT DEVICES OR SYSTEMS WITHOUT THE EXPRESS WRITTEN APPROVAL OF THE PRESIDENT AND GENERAL COUNSEL OF NATIONAL SEMICONDUCTOR CORPORATION. As used herein:

1. Life support devices or systems are devices or systems which, (a) are intended for surgical implant into the body, or (b) support or sustain life, and whose failure to perform when properly used in accordance with instructions for use provided in the labeling, can be reasonably expected to result in a significant injury to the user.
2. A critical component is any component of a life support device or system whose failure to perform can be reasonably expected to cause the failure of the life support device or system, or to affect its safety or effectiveness.

National Semiconductor Corporation
 Americas
 Tel: 1-800-272-9959
 Fax: 1-800-737-7018
 Email: support@nsc.com

National Semiconductor Europe
 Fax: +49 (0) 1 80-530 85 86
 Email: europe.support@nsc.com
 Deutsch Tel: +49 (0) 1 80-530 85 85
 English Tel: +49 (0) 1 80-532 78 32
 Français Tel: +49 (0) 1 80-532 93 58
 Italiano Tel: +49 (0) 1 80-534 16 80

National Semiconductor Asia Pacific Customer Response Group
 Tel: 65-2544466
 Fax: 65-2504466
 Email: sea.support@nsc.com

National Semiconductor Japan Ltd.
 Tel: 81-3-5639-7560
 Fax: 81-3-5639-7507

www.national.com