

UTC LM8560

MOS IC

DIGITAL ALARM CLOCK

DESCRIPTION

The LM8560 is alarm equipped digital clock IC with built-in driver capable of directly driving LED display equipment. As IC himself the VDD pin for the LM8560 is graded to withstand a voltage of 15V.

FEATURES

- *Single chip P-channel ED MOS LSI
- *LED direct drive using time division (duplex configuration)
- *Wide operating power supply voltage range
- *Built-in alarm function with 24-hour control
- *Supports changeover between 12-hour AM/PM and 24-hour displays
- *Built-in battery backup CR oscillator
- *Users 50Hz or 60Hz as standard frequency
- *Built-in automatic fast forward function for hour and minute settings
- *Built-in sleep timer function (maximum intervals of 59 minutes or 1 hours and 59 minutes)
- *Built-in snooze function supporting repeat use
- *Equipped with power failure display function
- *900Hz output for alarm tone

FUNCTIONS

- *Current time display
- *Snooze alarm function
- *Sleep timer function (maximum intervals of 59 minutes or 1 hours and 59 minutes)

APPLICATIONS

- *Alarm clocks
- *Clock radios

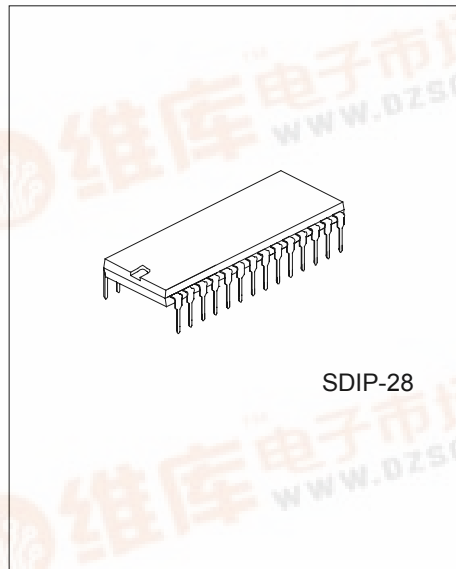

PIN CONFIGURATIONS

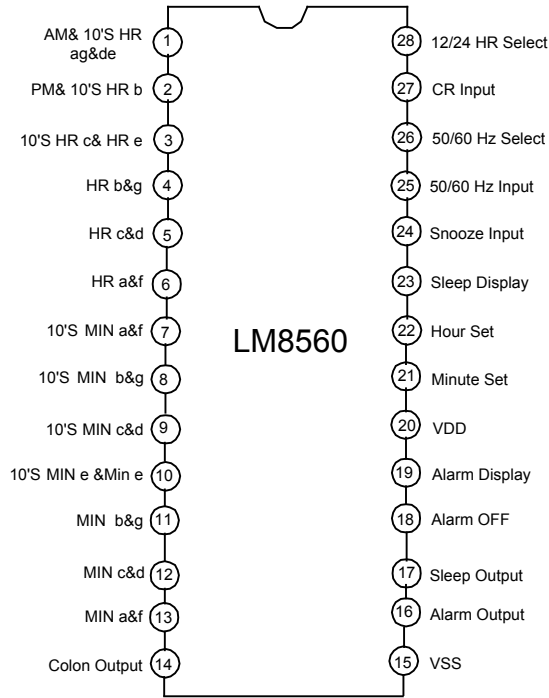

ABSOLUTE MAXIMUM RATINGS (Ta=25°C, Vss=0V)

PARAMETER	SYMBOL	TEST CONDITIONS	RATING	UNIT
Maximum Supply Voltage	VDD (max)		-15 ~ +0.3	V
Input Voltage1	VIN1	50/60Hz Input	-15 ~ +0.3	V
Input Voltage2	VIN2	Except 50/60Hz Input	-15 ~ +0.3	V
Output Voltage	VOUT		-15 ~ +0.3	V
Input Clamp Current	IIN	50/60Hz Input	-0.4 ~ +0.4	mA
Allowable Power Dissipation	Pd (max)	Ta=70°C	700	mW
Operating Temperature	Topr		-30 ~ +70	°C
Storage Temperature	Tstg		-55 ~ +125	°C

ALLOWABLE OPERATING RANGES (Ta=25°C, Vss=0V)

PARAMETER	SYMBOL	TEST CONDITIONS	MIN.	TYP.	MAX.	UNIT
Supply Voltage	VDD		-14		-7.5	V
Input "H" Level Voltage1	VIH1	50/60Hz Input	-1			V
Input "L" Level Voltage1	VIL1	50/60Hz Input			VDD+2	V
Input "H" Level Voltage2	VIH2	Except 50/60Hz Input	-1.5			V
Input "L" Level Voltage2	VIL2	Except 50/60Hz Input			VDD+2	V
50/60Hz Input Pin Input Voltage	VAC-IN	Sets Vss as Reference	VLED			V

ELECTRICAL CHARACTERISTICS (Ta=25°C, VDD=-12V unless otherwise specified)

PARAMETER	SYMBOL	TEST CONDITIONS	MIN.	TYP.	MAX.	UNIT
Input "H" Level Current 1	I _{IH1}	50/60Hz Input, V _{IN} =V _{SS}			10	μA
Input "L" Level Current 1	I _{IL1}	50/60Hz Input, V _{IN} =V _{DD}			10	μA
Input "H" Level Current 2	I _{IH2}	Input Pins Other Than 50/60Hz Input V _{IN} =V _{SS}			20	μA
Input "L" Level Current 2	I _{IL2}	Input Pins Other Than 50/60Hz Input V _{IN} =V _{DD}			10	μA
Output "H" Level Current 1	I _{OH1}	Alarm Output and Sleep Output V _{OH} =V _{SS} -1V	5			mA
Output Leakage Current 1	I _{OF1}	Alarm Output and Sleep Output V _{OUT} =V _{DD}			10	μA
Output "H" Level Current 2	I _{OH2}	AM & 10'S HR ag & de (24H mode) V _{OUT} =V _{DD} -1V	36			mA
Output Leakage Current 2	I _{OF2}	AM & 10'S HR ag & de (24H mode) V _{OUT} =V _{DD}			20	μA
Output "H" Level Current 3	I _{OH3}	Segment Output Other Than Those V _{OUT} =V _{SS} -1V	18			mA
Output Leakage Current 3	I _{OF3}	Segment Output Other Than Those Listed Above, V _{OUT} =V _{DD}			20	μA
Power failure detection Voltage	V _{DD}		-7.5	-5		V
Consumption Current	I _{CC}	Output set to off and Pull-down attached input set open		5	7	mA
Backup Oscillator Stability Factor	F _S	Standard Value,900Hz, V _{DD} =-9V±10%-10	-10		10	%
Backup Oscillator Accuracy	F _A	Standard Value,900Hz, V _{DD} =-9V-10	-10		10	%

DESCRIPTION OF OPERATIONS

*50/60Hz Input:

Built-in Shmidt circuit enables noise eliminations at 50/60Hz commercial frequencies with use of a simple CR filter. Built-in pull-up resistor.

*CR Input:

When the AC power supply is interrupted, the time counter switches to a holding state and a built-in oscillator promptly begins operation. If 50/60Hz input continues for 3 clocks without arriving, this oscillator's output is activated and functions as the time counter clock in place of 50/60Hz input. The frequency level of this clock oscillator is determined according to the CR value. While the above mentioned oscillator is operating using backup mode, all segment output is switched to OFF.

(Note) When the backup oscillator is in use due to an AC power supply interruption, the 50/60Hz input pin must be maintained open or at a V_{SS} level.

*50/60 Selective Input:

When 50/60 selective input is connected to V_{SS}, 50Hz use is enabled. When 50/60 selective input is left open, V_{DD} is activated using an internal pull-down resistor and the setting is switched to enable use at 60Hz.

*Display Mode Selective Input (Alarm Select/Sleep Select):

Since the pull-down resistor is built-in, selection from four display modes is possible using two SPST switches (single-pole and single-throw switches). Table 1 shows these display mode selections.

Table1 Display Modes

Selective Input		Display Mode	Digit No. 1	Digit No. 2	Digit No. 3	Digit No.4
Alarm	Sleep					
NC	NC	Time display	10's place for hour, AM/PM	Hour	10's place for Minute	Minute
Vss	NC	Alarm display	10's place for hour, AM/PM	Hour	10's place for Minute	Minute
NC	Vss	Sleep display	Clear	Hour	10's place for Minute	Minute
Vss	Vss	Second display	Clear	Minute	10's place for Second	Second

Note: Activating Vss using two inputs simultaneously (alarm select and sleep select), the display mode is switched to display seconds.

*Time Setting Input:

There are two setting inputs for use with "hour" and "minute". Time content settings show in Table2 are possible by activating Vss to these pins, A pull-down resistor is built-in.

Table2 Setting contents

Display Mode	Set Input	Functions
Time	Hour	Immediately adds 1 to hour digits and then assigns an additional 1, at a speed of 2 Hz, after each 1/4 to 3/4 second.
	Min	Immediately adds 1 to minute digits and then assigns an additional 1, at a speed of 2 Hz, after each 1/4 to 3/4 second. Seconds are rest.
	Both	Operates both as outline above.
Second (Alarm & Sleep)	Hour (note1)	Second digits are cleared to [00].
	Min	Time holds.
	Both (note2)	Resets hour and minute digits as [0:00] when operating in 24-H mode or [12:00] when operating in 12-H mode.
Alarm	Hour	Immediately adds 1 to hour digits and then assigns an additional 1, at a speed of 2 Hz, after each 1/4 to 3/4 second.
	Min	Immediately adds 1 to minute digits and then assigns an additional 1, at a speed of 2 Hz, after each 1/4 to 3/4 second.
	Both	Resets hour and minute digits as [0:00] when operating in 24-hour mode or [12:00] when operating in 12-hour mode.
Sleep	-	Sets sleep counter to [0:59] instantly when VDD is activated to sleep select
	Hour	Sets Sleep counter to [1:59] instantly when VDD is activated to sleep select and hour at the same time.
	Min	Sleep counter looses 1 at a speed of 2 Hz.
	Both	Sleep counter looses 1 at a speed of 2 Hz.

Note:1.Once conditions have been switched to reset or hold, input of other functions is locked until both Hour and Min input have been separated.

2.When the digital reading for seconds is between 30 and 59 seconds, 1 is added to the digits for minutes as he digital reading for seconds rests to [00].

*12/24H Select Input :

When this pin set open (VDD), a 12-hour display is enabled whereas connecting this pin to Vss enables the 24-hour display. A pull-down resistor is build-in.

*Power Failure Detection Display :

When activated by drop in power supply, all segments which are lit begin to blink and the unit switches to a power failure detection display. The power failure detection display is canceled by activating Vss to Hours set or Min set.

*Alarm Operation and Alarm Output :

The alarm signal outputs when alarm content matches the content of current time. When not rest by either snooze input or alarm off input, output continues after 1 hour and 59 minutes. This output signal consists of 900Hz 2Hz intermittent (50% duty) modulation signals, When the need arises , a filter can be applied to after the alarm signal to a DC signal.

*Snooze Input :

When the alarm is sounding and instantly activating Vss to this pin , alarm output is set to OFF for a period between 8 and 9 minutes after which time the alarm signal is once again output. The snooze function can be used repeatedly in 1 hours and 59 minutes intervals. A pull-down resistor is built-in. Activating Vss to the snooze pin when the alarm is OFF resets the sleep timer counter to [0:00](This is known as the one-touch sleep timer reset function.)

*Alarm Off Input :

Activating this input pin to VSS instantly sets alarm output to OFF. A pull-down resistor is built-in.

*Sleep Timer and Sleep Output :

Sleep output can turn on the radio and can be set for time intervals of 59 minutes or 1 hour and 59 minute. Refer to Table 2 for the proper selection procedure (59 minutes or 1 hour and 59 minute selection.) This sleep timer is constructed using a down counter and when the counter content arrives at [00], output is set to off and the radio turns off. Adding Vss to snooze input turns sleep output off. When sleep output is on.

BLOCK DIAGRAM

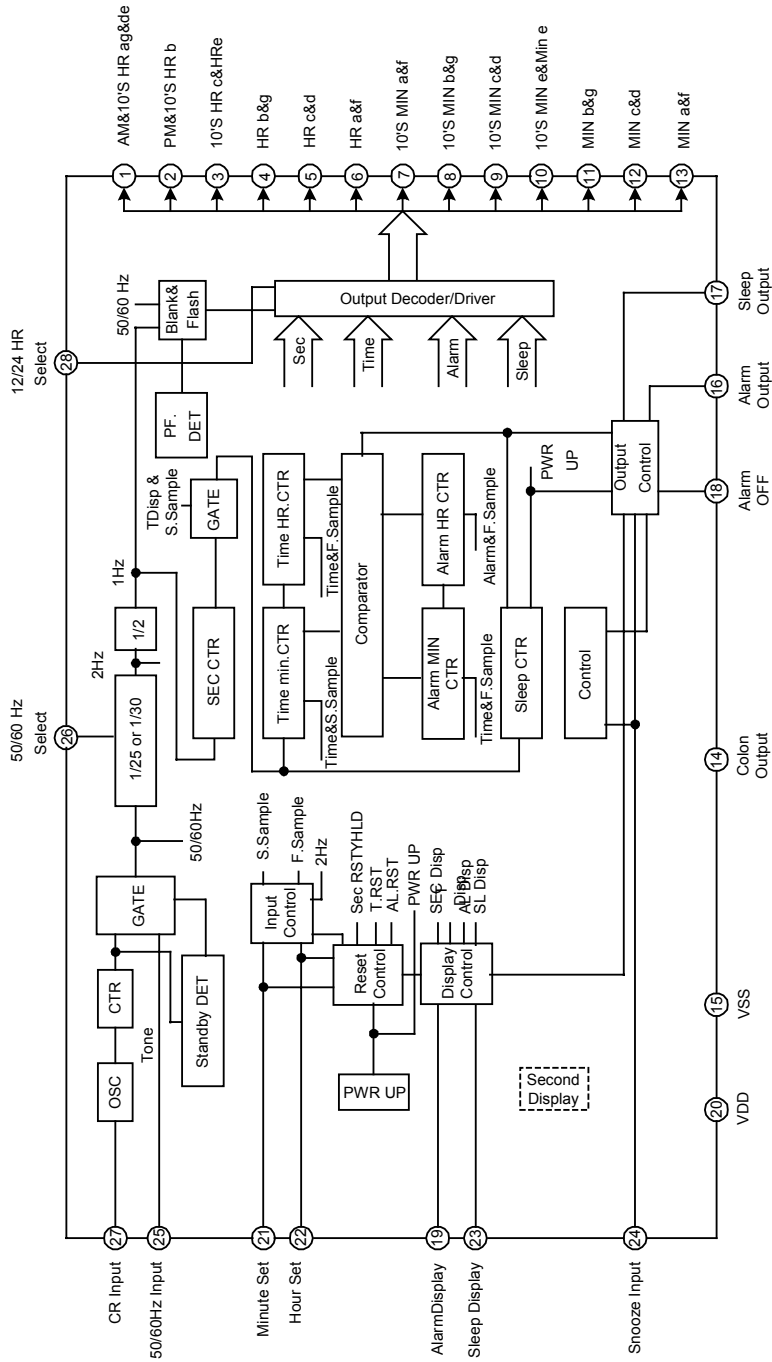

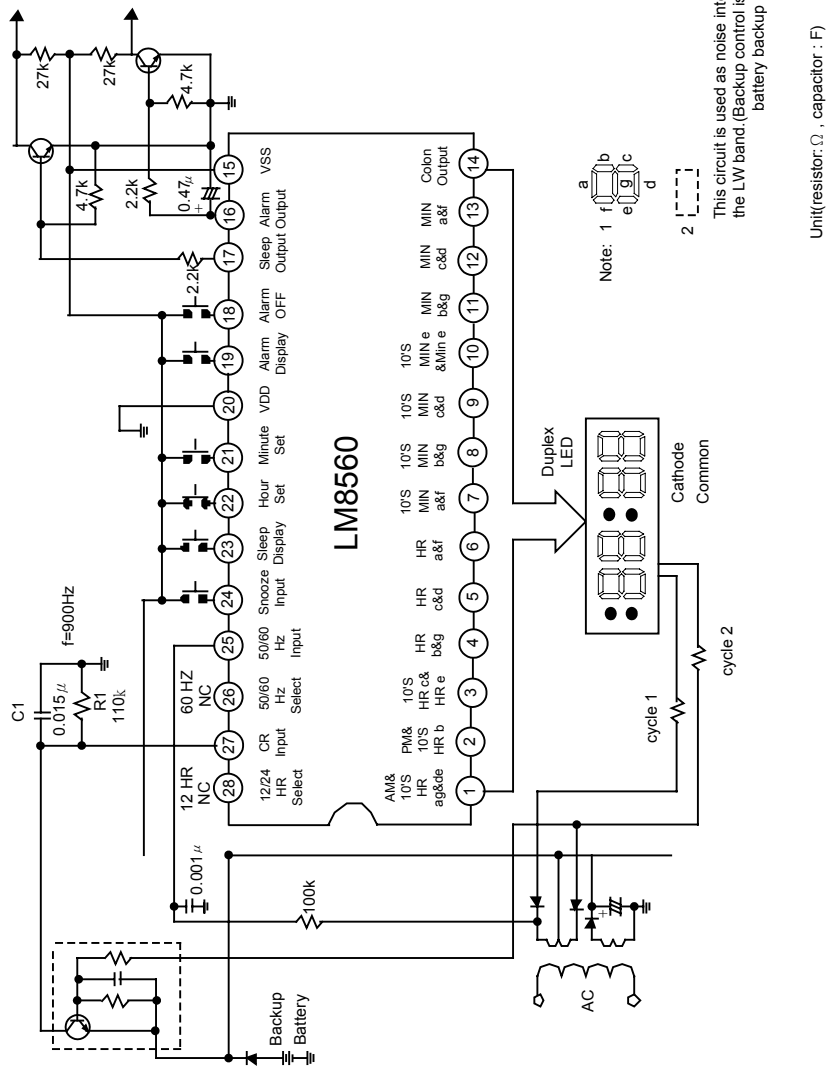

12 Hour Display and 60Hz Circuit Diagram

UTC assumes no responsibility for equipment failures that result from using products at values that exceed, even momentarily, rated values (such as maximum ratings, operating condition ranges, or other parameters) listed in products specifications of any and all UTC products described or contained herein. UTC products are not designed for use in life support appliances, devices or systems where malfunction of these products can be reasonably expected to result in personal injury. Reproduction in whole or in part is prohibited without the prior written consent of the copyright owner. The information presented in this document does not form part of any quotation or contract, is believed to be accurate and reliable and may be changed without notice.