

M57962L

HYBRID IC FOR DRIVING IGBT MODULES

Block Diagram

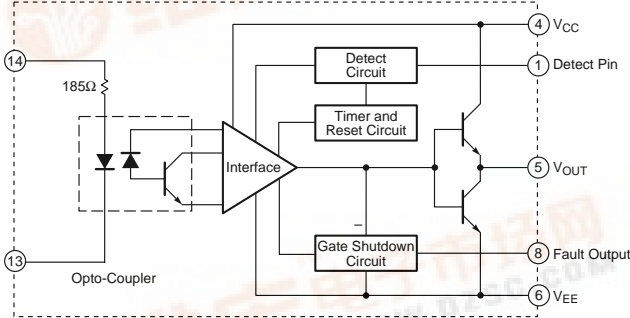

Outline Drawing

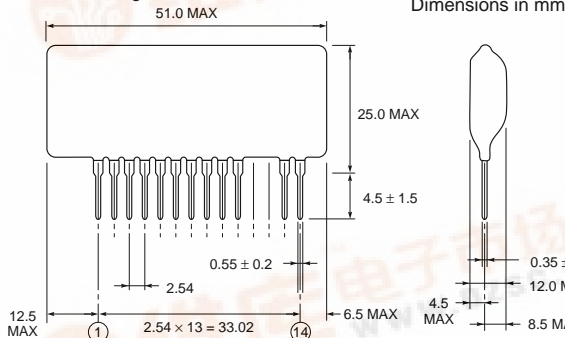

Test Circuit

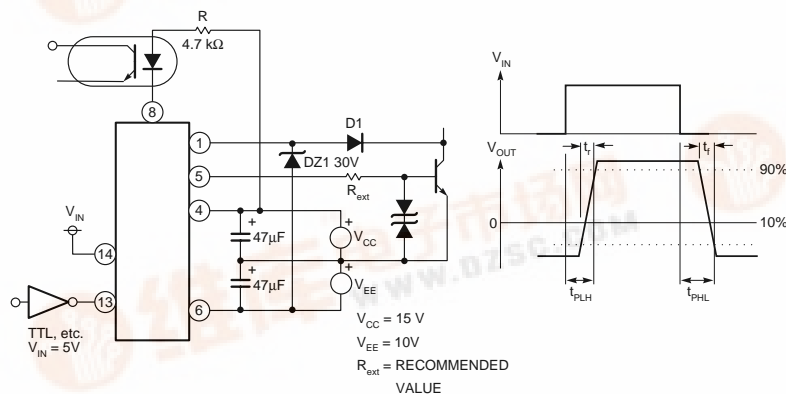

Hybrid Integrated Circuit For Driving IGBT Modules

Description:

M57962L is a hybrid integrated circuit designed for driving n-channel IGBT modules in any gate amplifier application. This device operates as an isolation amplifier for these modules and provides the required electrical isolation between the input and output with an opto-coupler. Short circuit protection is provided by a built in desaturation detector. A fault signal is provided if the short circuit protection is activated.

Features:

- Built in high CMRR opto-coupler (V_{CMR} : Typical 30kV/ μs , Min. 15kV/ μs)
- Electrical Isolation between input and output with opto-couplers ($V_{iso} = 2500$, V_{RMS} for 1 min.)
- TTL compatible input interface
- Two supply drive topology
- Built in short circuit protection circuit with a pin for fault output

Application:

To drive IGBT modules for inverter, AC Servo systems, UPS, CVCF inverter, and welding applications.

Recommended Modules:

$V_{CES} = 600\text{V}$ Series
(up to 400A Class)

$V_{CES} = 1200\text{V}$ Series
(up to 200A Class)

$V_{CES} = 1400\text{V}$ Series
(up to 200A Class)

HYBRID IC FOR DRIVING IGBT MODULES

Absolute Maximum Ratings, $T_a = 25^\circ\text{C}$ unless otherwise specified

Item	Symbol	Test Conditions	Limit	Units
Supply Voltage*	V_{CC}	DC	18	Volts
	V_{EE}	DC	-15	Volts
Input Voltage	V_I		-1 ~ 7	Volts
Output Voltage	V_O	Output Voltage "H"	V_{CC}	Volts
Output Current	I_{OHP}	Pulse Width 2 μs , $f = 20\text{kHz}$	-5	Amperes
	I_{OLP}	Pulse Width 2 μs , $f = 20\text{kHz}$	5	Amperes
Output Current	I_{OH}	$f = 20\text{kHz}$, 50% Duty Cycle	0.5	Amperes
Isolation Voltage	V_{RMS}	Sinewave Voltage 60Hz, 1 min.	2500	Volts
Junction Temperature	T_j		85	$^\circ\text{C}$
Operating Temperature	T_{opr}	(Differs from H/C Condition)	-20 ~ 60	$^\circ\text{C}$
Storage Temperature	t_{stg}		-25 ~ 100	$^\circ\text{C}$
Fault Output Current	I_{FO}		20	mA
Input Voltage	V_{R1}		50	Volts

*20 Volts $\leq V_{CC} + V_{EE} \leq 28$ Volts**Electrical Characteristics, $T_a = 25^\circ\text{C}$, $V_{CC} = 15\text{V}$, $-V_{EE} = 10\text{V}$ unless otherwise specified**

Characteristics	Symbol	Test Conditions	Min.	Typ.	Max.	Units
Supply Voltage	V_{CC}	Recommended Range	14	15	—	Volts
	V_{EE}	Recommended Range	-7	—	-10	Volts
Pull-up Voltage on Input Side	V_{IN}	Recommended Range	4.75	5.00	5.25	Volts
"H" Input Current	I_{IH}	$V_{IN} = 5\text{V}$, $R = 185\Omega$	—	16	—	mA
"H" Output Voltage	V_{OH}		13	14	—	Volts
"L" Output Voltage	V_{OL}		-8	-9	—	Volts
Internal Power Dissipation	P_D	$f = 20\text{kHz}$,	—	2.38	—	Watts
		Module 400A, 1200V IGBT				
"L-H" Propagation Time	t_{PLH}	$V_I = 0$ to 4V, $T_j \pm 85^\circ\text{C}$	—	1.0	1.5	μs
"L-H" Rise Time	t_r	$V_I = 0$ to 4V, $T_j \pm 85^\circ\text{C}$	—	0.6	1.0	μs
"H-L" Propagation Time	t_{PHL}	$V_I = 0$ to 4V, $T_j \pm 85^\circ\text{C}$	—	1.0	1.5	μs
"H-L" Rise Time	t_r	$V_I = 0$ to 4V, $T_j \pm 85^\circ\text{C}$	—	0.4	1.0	μs
Reset Time of Protection	t_{RESET}		1	—	2	ms
Fault Output Current	I_{FO}		—	5	—	mA
SC Voltage	V_{SC}		15	—	—	Volts