

MAXIM

MAX2291 Evaluation Kit

Evaluates: MAX2291

General Description

The MAX2291 evaluation kit (EV kit) simplifies evaluation of the MAX2291 power amplifier (PA). It enables testing of the device's RF performance and requires no additional support circuitry. The EV kit's signal inputs and outputs use SMA connectors to facilitate the connection of RF test equipment.

Three versions of the MAX2291 EV kit are available, covering N-CDMA, TDMA, and WCDMA/UMTS.

Component Suppliers

SUPPLIER	PHONE	FAX
Alpha	360-647-2360	360-671-4936
ATC	949-583-9119	949-583-9213
Coilcraft	847-639-6400	847-639-1469
Kayama	219-489-1533	219-489-2261
Murata	770-436-1300	770-436-3030

Features

- ◆ Easy Evaluation of the MAX2291
- ◆ +2.7V to +4.2V Single-Supply Operation
- ◆ Jumpers for Digital Power Control and Shutdown
- ◆ All Critical Peripheral Components Included

Ordering Information

PART	TEMP RANGE	IC PACKAGE
MAX2291NCDMAEVKIT	-40°C to +85°C	5 × 5 UCSP
MAX2291TDMAEVKIT	-40°C to +85°C	5 × 5 UCSP
MAX2291WCDMAEVKIT	-40°C to +85°C	5 × 5 UCSP

Component List

N-CDMA

DESIGNATION	QTY	DESCRIPTION
C17, C46, C47, C50, L8, L12, R2, IN2SMA	0	Not installed
C45, C54, C57, C64	4	0.01µF capacitors, Murata GRM36X7R103K16
C48	1	470pF capacitor, Murata GRM36X7R471K50
C49	1	6.0pF ±0.1pF capacitor, Murata GRM36COG6R0B50
C52	1	1.6pF ±0.1pF capacitor, Murata GRM36COG1R6B50
C56	1	10pF ±0.1pF capacitor, Murata GRM36COG100B50
C58	1	5.0pF ±0.1pF capacitor, Murata GRM36COG5R0B50
C62	1	0.1µF capacitor, Murata GRM39X7R104K16
C65	1	10µF, 6.3V, 100mΩ Taiyo Yuden ceramic capacitor, 1206 case size
C66	1	22pF capacitor, Murata GRM36COG220J50

DESIGNATION	QTY	DESCRIPTION
C90	1	4.7pF ±0.1pF capacitor, ATC ATC100A4R7BW150XB
C91	1	1.6pF ±0.1pF capacitor, ATC ATC100A1R6BW150XB
C92	1	0.75pF ±0.1pF capacitor, Murata GRM36COGR75B50
D1	1	Pin diode, Alpha SMP1320-079
L9, L15	2	0Ω ±5% resistors
L11	1	2.55nH inductor, Coilcraft 0906-3
L14	1	33nH inductor, Murata LQP10A33G00
R14	1	27.4kΩ ±1% resistor (0402)
R16	1	24kΩ ±5% resistor (0402)
R17, R18	2	15kΩ ±1% resistors (0402)
R19	1	8.2kΩ ±1% resistor (0402)
U1	1	MAX2291 5 × 5 UCSP™
VCC, GND	2	Banana jacks (red for VCC and black for GND), solder to 2-pin headers straight up
VCC, GND	2	2-pin headers (0.1in centers)
IN1, OUT	2	0.031in edge-mount SMAs
JU1, JU2	2	3-pin headers (0.1in centers)

UCSP is a trademark of Maxim Integrated Products, Inc.



MAX2291 Evaluation Kit

Component List

TDMA

DESIGNATION	QTY	DESCRIPTION
C17, C49, C50, C52, C54, C58, D1, R2, IN2SMA, L9, L14, L15, R17, R19	0	Not installed
C45, C57, C64	3	0.01 μ F capacitors, Murata GRM36X7R103K16
C48	1	470pF capacitor, Murata GRM36X7R471K50
C49	1	5.0pF capacitor, Murata GRM36COG050C50
C56	1	10pF \pm 5% capacitor, ATC ATC650L100JW25
C62	1	0.01 μ F capacitor, Murata GRM39X7R103K16
C65	1	10 μ F, 6.3V, 100m Ω , Taiyo Yuden ceramic capacitor, 1206 case size
C66	1	22pF capacitor, Murata GRM36COG220J50
C90	1	4.7pF \pm 0.1pF capacitor, ATC ATC100A4R7BW150XB
C91	1	1.8pF \pm 0.1pF capacitor, ATC ATC100A1R8BW150XB
L9	1	1.2nH, Murata LQP10A1N2B00
L11	1	2.55nH inductor, Coilcraft 0906-
L14	1	33nH inductor, Murata LQP10A33G00
R14	1	16.2k Ω \pm 1% resistor (0402)
R16	1	24k Ω \pm 5% resistor (0402)
R18	1	15k Ω \pm 1% resistor (0402)
U1	1	MAX2291 5 \times 5 UCSP
VCC, GND	2	Banana jacks (red for VCC and black for GND), solder to 2-pin headers straight up
VCC, GND	2	2-pin headers (0.1in centers)
IN1, OUT	2	0.031in edge-mount SMAs
JU1	1	3-pin header (0.1in centers)

WCDMA

DESIGNATION	QTY	DESCRIPTION
C17, C46, C47, C50, L8, L12, D1, R2, IN2SMA, JU9, R15	0	Not installed
C45, C54, C57, C64	4	0.01 μ F capacitors, Murata GRM36X7R103K16
C48	1	470pF capacitor, Murata GRM36X7R471K50
C49	1	5.6pF \pm 0.1pF capacitor, Murata GRM36COG5R6B50
C52	1	1.3pF \pm 0.1pF capacitor, Murata GRM36COG1R3B50
C56	1	9.1pF \pm 0.1pF capacitor, Murata GRM36COG9R1B50
C66	1	22pF capacitor, Murata GRM36COG220J50
C58	1	4.0pF \pm 0.1pF capacitor, Murata GRM36COG4R0B50
C62	1	0.01 μ F capacitor, Murata GRM39X7R103K16
C65	1	10 μ F, 6.3V, 100m Ω , Taiyo Yuden ceramic capacitor, 1206 case size
C90	1	3.9pF \pm 0.1pF capacitor, ATC ATC100A3R9BW150XB
C91	1	3.3pF \pm 0.1pF capacitor, ATC ATC100A3R3BW150XB
C92	1	0.5pF \pm 0.1pF capacitor, Murata GRM36COG0R5B50
D1	1	Pin diode, Alpha SMP1320-079
L9, L15	2	0 Ω \pm 5% resistors
L11	1	2.55nH inductor, Coilcraft 0906-3
L14	1	33nH inductor, Murata LQP10A33G00
R14	1	20k Ω \pm 1% resistor (0402)
R16	1	24k Ω \pm 5% resistor (0402)
R17, R18	2	15k Ω \pm 1% resistor (0402)
R19	1	8.25k Ω \pm 1% resistor (0402)
U1	1	MAX2291 5 \times 5 UCSP
VCC, GND	2	Banana jacks (red for VCC and black for GND), solder to 2-pin headers straight up
VCC, GND	2	2-pin headers (0.1in centers)
IN1, OUT	2	0.031 in edge-mount SMAs
JU1, JU2	2	3-pin headers (0.1in centers)

MAX2291 Evaluation Kit

Component List

KOREAN BAND CDMA

DESIGNATION	QTY	DESCRIPTION
C17, C46, C47, C50, L8, L12, D1, R2, IN2SMA	0	Not installed
C45, C54, C57, C64	4	0.01 μ F capacitors, Murata GRM36X7R103K16
C48	1	470pF capacitor, Murata GRM36X7R471K50
C49	1	6.8pF \pm 0.1pF capacitor, Murata GRM36COG6R8B50
C52	1	1.6pF \pm 0.1pF capacitor, Murata GRM36COG1R6B50
C56, C66	2	22pF capacitors, Murata GRM36COG220J50
C58	1	5.0pF \pm 0.1pF capacitor, Murata GRM36COG5R0B50
C62	1	0.01 μ F capacitor, Murata GRM39X7R103K16
C65	1	10 μ F, 6.3V, 100m Ω , Taiyo Yuden ceramic capacitor, 1206 case size

DESIGNATION	QTY	DESCRIPTION
C90	1	4.7pF \pm 0.1pF capacitor, ATC ATC100A4R7BW150XB
C91	1	1.8pF \pm 0.1pF capacitor, ATC ATC100A1R8BW150XB
C92	1	1.6pF \pm 0.1pF capacitor, Murata GRM36COG1R6B50
D1	1	Pin diode, Alpha SMP1320-079
L9	1	0 Ω \pm 5% resistor
L11	1	2.55nH inductor Coilcraft 0906-3
L14	1	33nH inductor, Murata LQP10A33G00
L15	1	1.2nH inductor, Murata LQP10A1N2B00
R14	1	27.4k Ω \pm 1% resistor (0402)
R16	1	24k Ω \pm 5% resistor (0402)
R17, R18	2	15k Ω \pm 1% resistors (0402)
R19	1	8.25k Ω \pm 1% resistor (0402)
U1	1	MAX2291 5 \times 5 UCSP
VCC, GND	2	Banana jacks (red for VCC and black for GND), solder to 2-pin headers straight up
VCC, GND	2	2-pin headers (0.1in centers)
IN1, OUT	2	0.031in edge-mount SMAs
JU1, JU2	2	3-pin headers (0.1in centers)

Evaluates: MAX2291

MAX2291 Evaluation Kit

Quick Start

MAX2291 EV kits are fully assembled and factory tested. Follow the instructions in the *Connections and Setup* section for proper device evaluation.

Test Equipment Required

This section lists the test equipment recommended to verify operation of the MAX2291. It is intended as a guide only, and some substitutions are possible:

- One RF signal generator capable of delivering at least +5dBm of output power at the operating frequency (HPE4433B or equivalent)
- One RF power sensor capable of handling at least +20dBm of output power at the operating frequency (HP 8482A or equivalent)
- One RF power meter capable of measuring up to +20dBm of output power at the operating frequency (HP 437B or equivalent)
- An RF spectrum analyzer that covers the MAX2291 operating frequency range, as well as a few harmonics (FSEB20, for example)
- A power supply capable of up to 1A at +2.7V to +4.2V
- An optional ammeter for measuring the supply current
- Two SMA cables
- One SMA 20dB pad
- A network analyzer (HP 8753D, for example) to measure small-signal return loss and gain (optional)

Connections and Setup

This section provides a step-by-step guide to operating the EV kit and testing the device's function. Do not turn on the DC power or RF signal generators until all connections are made.

- 1) Connect a DC supply set to +3.5V (through an ammeter if desired) to the VCC and GND terminals on the EV kit. Do not turn on the supply.
- 2) Connect one RF signal generator to the IN1 SMA connector; do not turn on the generator's output. Set the generator for output frequency and power level according to Table 1.
- 3) Connect a 20dB pad to the OUT SMA connector on the EV kit. This is to prevent overloading of the power sensor and the power meter.
- 4) Connect a power sensor to the 20dB pad.
- 5) Connect the power sensor to a power meter. Set the power meter offset to 20dB and frequency according to Table 1. For more accuracy, measure the actual offset.
- 6) Connect jumpers JU1 and JU2 to make $\overline{\text{SHDN}} = \text{VCC}$, $\text{MODE} = \text{GND}$. This sets the MAX2291 to high-power mode. The MAX2291 EV kit is shipped in this setting.
- 7) Turn on the DC supply. The supply current should read approximately 170mA.
- 8) Activate the RF generator's output. The power meter should read approximately +29dBm (N-CDMA). The supply current should increase to approximately 630mA (N-CDMA). See Table 1 for approximate readings in other modes.
- 9) Another method for determining gain is by using a network analyzer (optional). This has the advantage of displaying gain versus a swept-frequency band, in addition to displaying input return loss. Refer to the network analyzer manufacturer's user manual for setup details.

Table 1. Typical Operating Conditions

PARAMETER	N-CDMA	TDMA	KCDMA	WCDMA	UNITS
Frequency	1880	1880	1765	1950	MHz
Signal Generator Power	+2	+3	+2	+1	dBm
Output Power	+29	+30.5	+29	+28	dBm
Supply Current	630	800	630	480	mA

MAX2291 Evaluation Kit

Evaluates: MAX2291

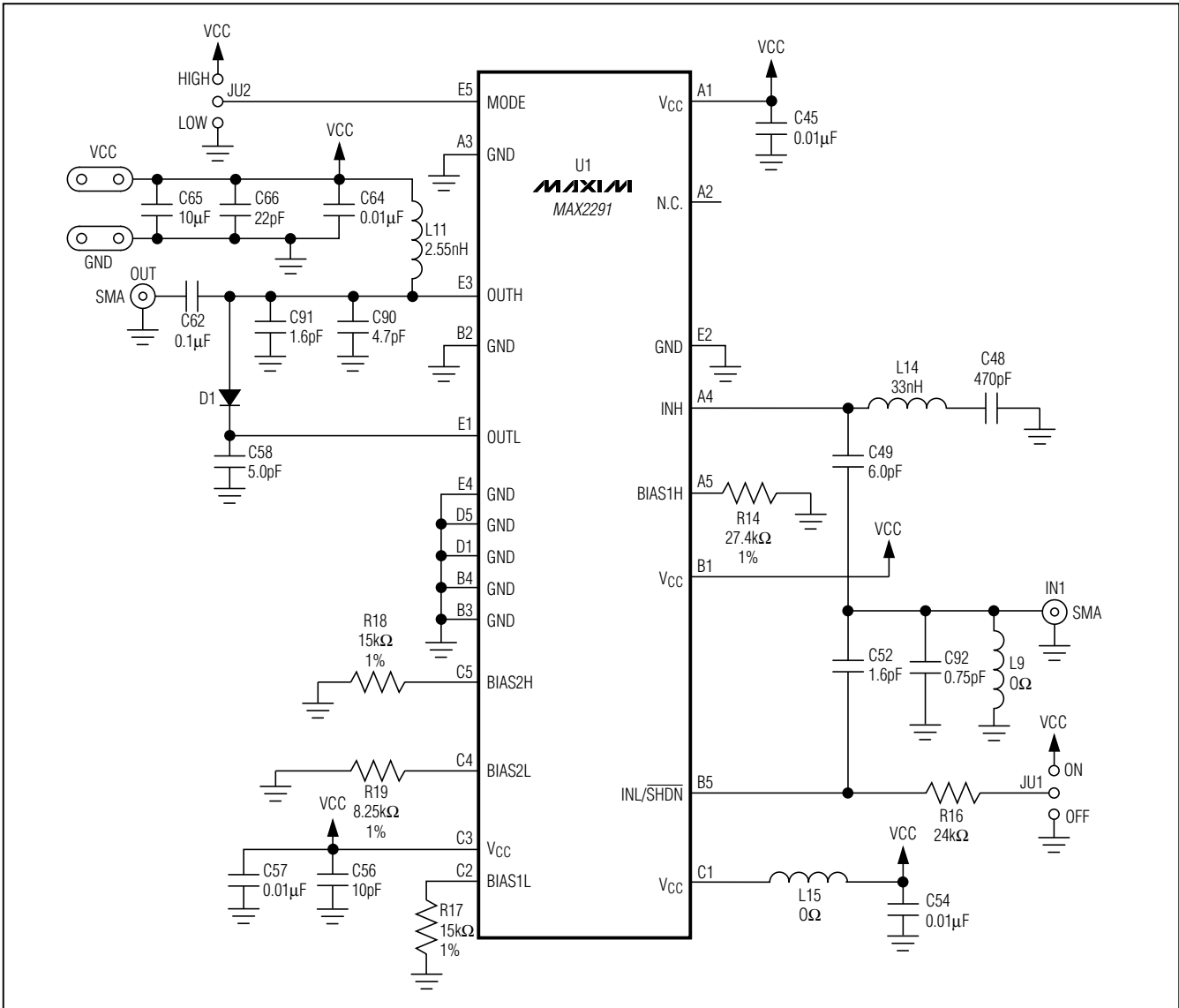

Figure 1. MAX2291 N-CDMA EV Kit Schematic

MAX2291 Evaluation Kit

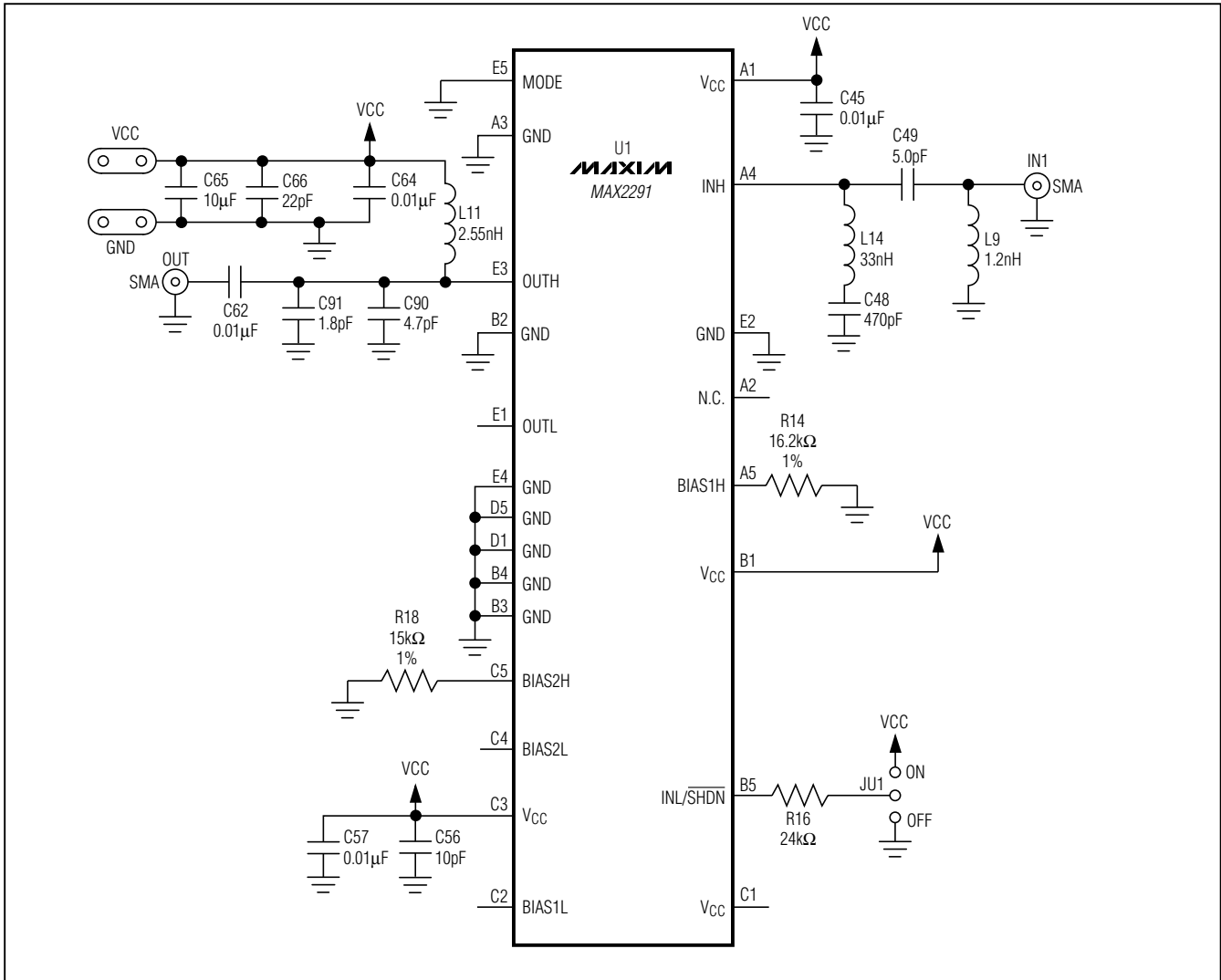

Figure 2. MAX2291 TDMA EV Kit Schematic

MAX2291 Evaluation Kit

Evaluates: MAX2291

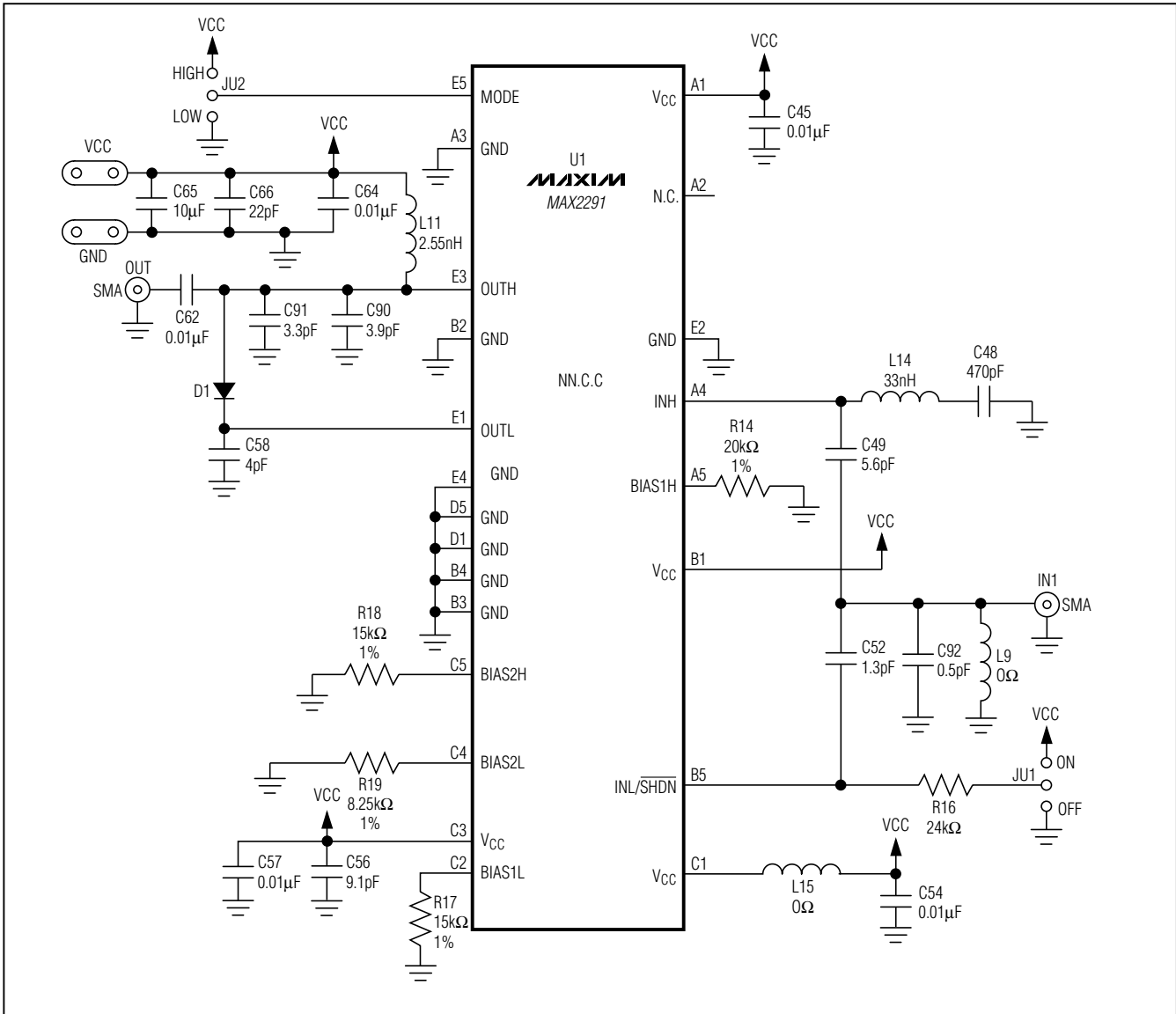

Figure 3. MAX2291 WCDMA EV Kit Schematic

MAX2291 Evaluation Kit

Evaluates: MAX2291

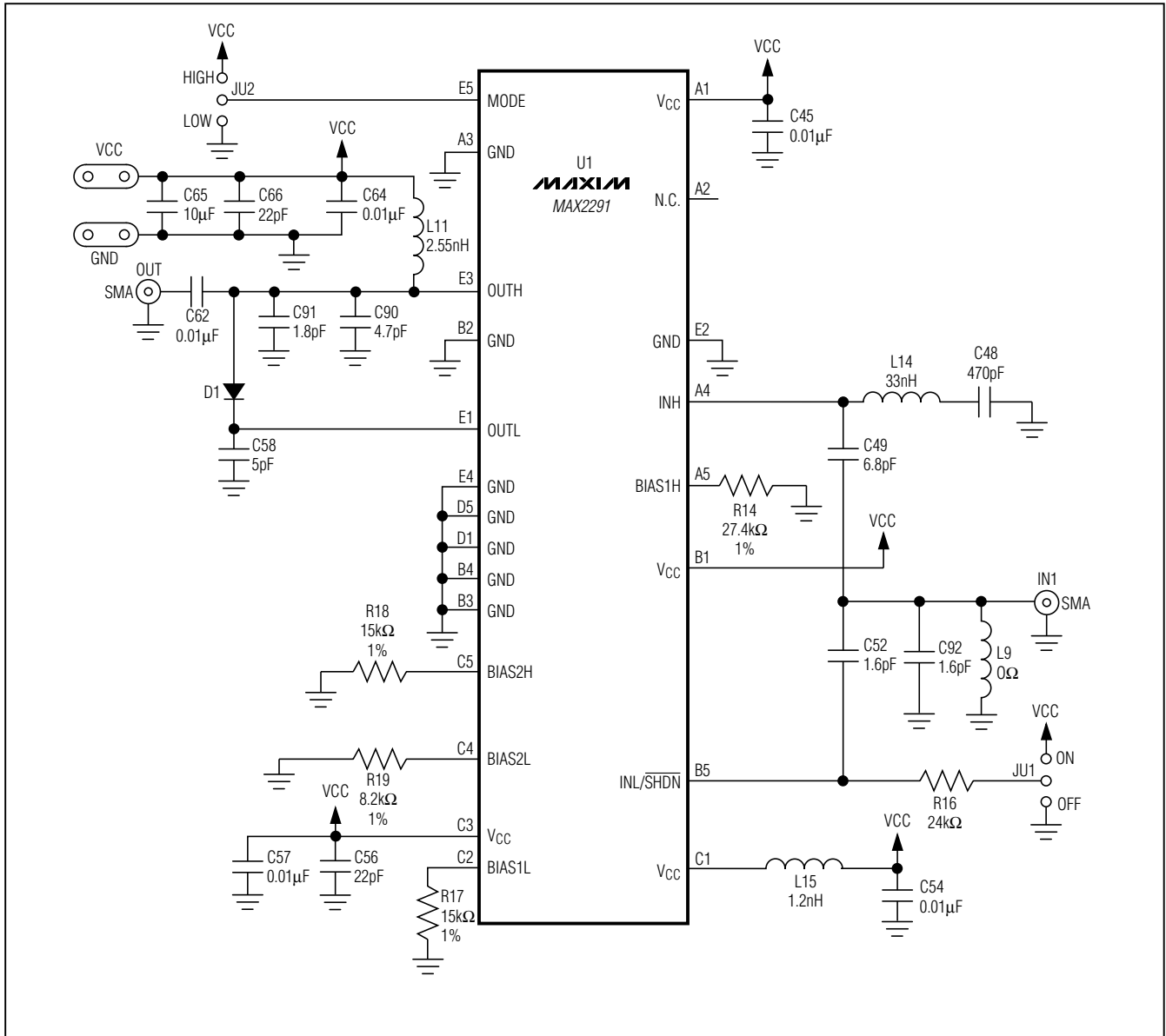

Figure 4. MAX2291 Korean CDMA EV Kit Schematic

MAX2291 Evaluation Kit

Evaluates: MAX2291

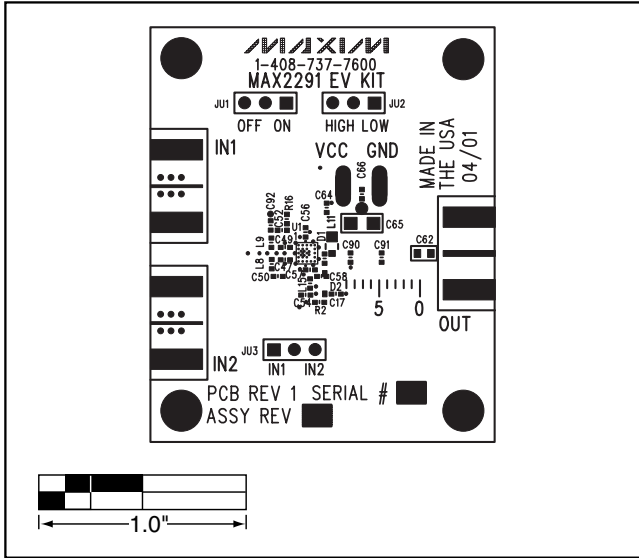

Figure 5. MAX2291 EV Kit Component Placement Guide—Component Side

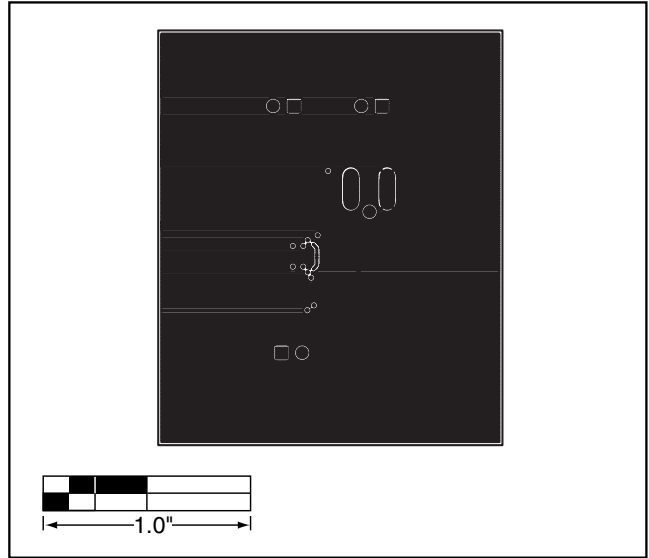

Figure 6. MAX2291 EV Kit PC Board Layout—Ground Plane Layer 2

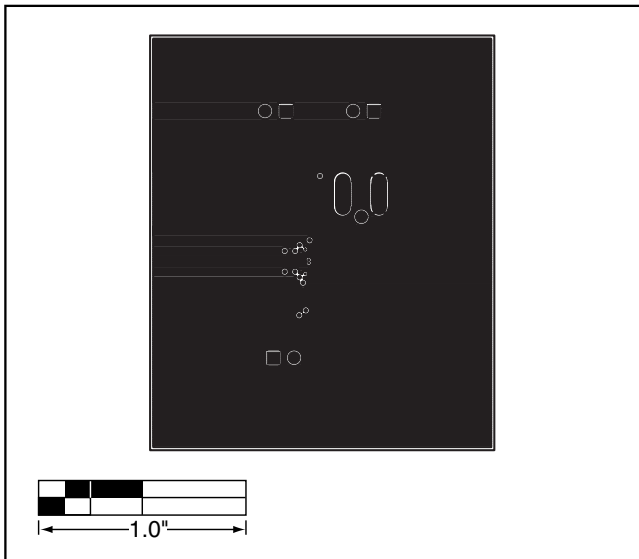

Figure 7. MAX2291 EV Kit PC Board Layout—Ground Plane Layer 3

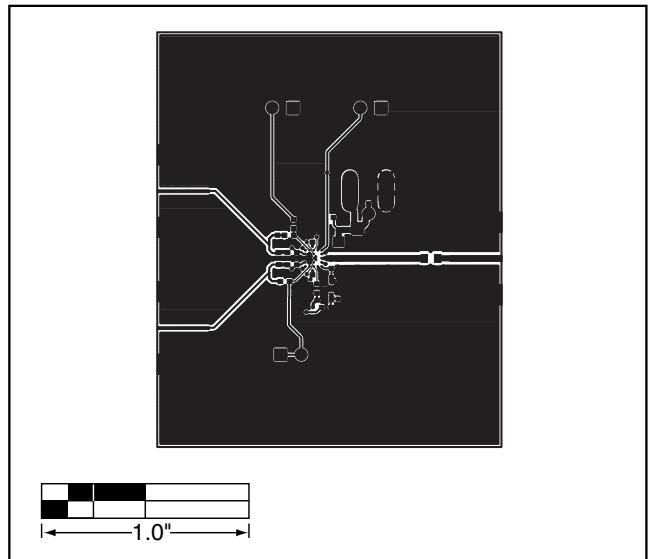

Figure 8. MAX2291 EV Kit PC Board Layout—Component Side

MAX2291 Evaluation Kit

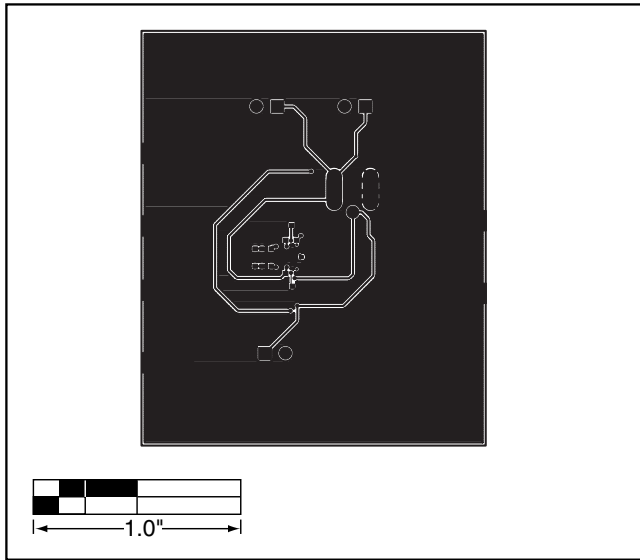

Figure 9. MAX2291 EV Kit PC Board Layout—Secondary Side

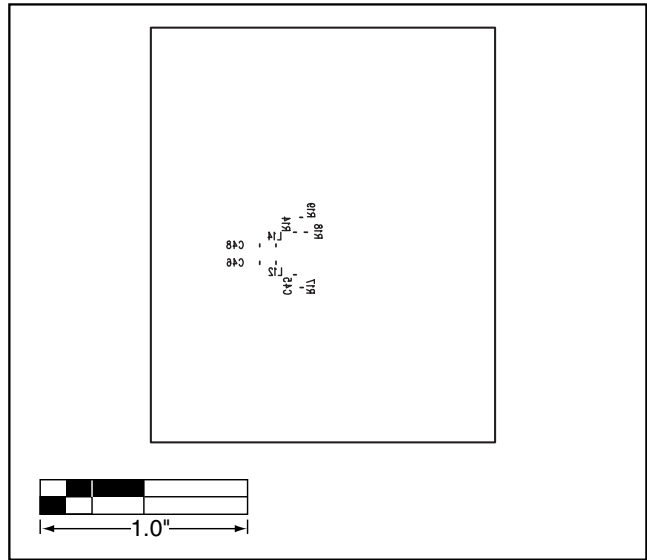

Figure 10. MAX2291 EV Kit PC Board Layout—Back Side.

Maxim cannot assume responsibility for use of any circuitry other than circuitry entirely embodied in a Maxim product. No circuit patent licenses are implied. Maxim reserves the right to change the circuitry and specifications without notice at any time.