



Wednesday, February 20, 2002

ML2860 SPECIFICATION ver 1.0.0

Oki Electric Industry Co.Ltd.

# ML2860 DATA SHEET

16-Tone, 32-Poly Hi-Grade PCM Sound Generator LSI

Version 1.0.1, Revised on Wednesday, February 20, 2002

## GENERAL DESCRIPTION

ML2860 is a PCM-based hi-grade sound generator LSI, developed specifically for music ringers as used in cellular/PHS phones. With an on-chip high-quality General MIDI sound set, ML2860 is capable of playing 16 tones and 32 polyphonies simultaneously. Using the on-chip three FIFOs which store musical score data, MIDI message and ADPCM audio data, a fantastic music ringer subsystem can readily be built around this chip.

## FEATURES

- 1) Supports GM System level 1
- 2) On-chip high-quality GM sound set
- 3) 128 timbres + 48 percussions embedded
- 4) 16 timbres, 32 polyphonies simultaneously (default setting is 24)
- 5) 5V open drain ports with current control for vibrator, front panel light, LED x 4
- 6) 3-wire serial / 8-bit parallel bus selectable
- 7) FIFO embedded for CPU power reduction
- 8) Power down current: 1μA (typ.)
- 9) Operating current: 60mA (max.)
- 10) Power supply: +2.7 ~ 3.3V
- 11) Operating temperature: -20 ~ +85°C
- 12) Internal stereo earphone amplifier & DAC

## APPLICATION EXAMPLES

Mobile phone, PHS, Fax, PDA

### (Note)

Please appreciate that ML2860 is not offered for musical instrument and toy applications, such as keyboards.

## PACKAGE SPECIFICATION

48PIN W-CSP (P-VFLGA48-6.26x5.98-0.80-W)

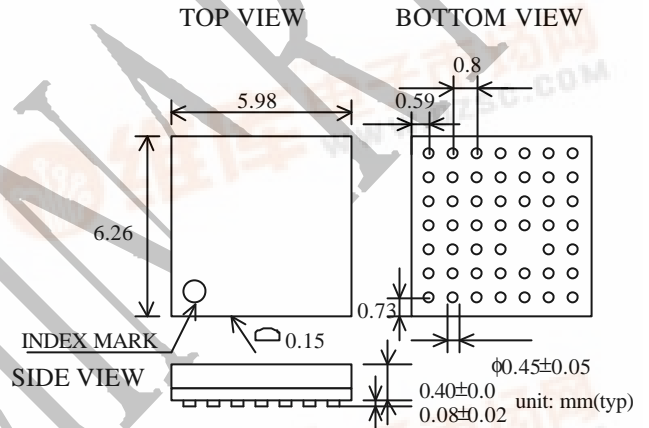

## ABSOLUTE MAXIMUM RATINGS

Parameter	Symbol	Condition	Rating	Unit
Supply Voltage	VDD	Ta=25°C	-0.3 - +5.0	V
Input Voltage 1 *1	VIN		-0.3 - VDD+0.3	V
Input Voltage 2 *1	VIN		-0.3 - +5.5	V
Power Dissipation	Pd		320	mW
Storage Temperature	TSTG	-	-55 - +125	°C

## RECOMMENDED OPERATING RANGES

Parameter	Symbol	Condition	Rating	Unit
Supply Voltage	DVDD	DGND=AGND=0V	2.7 - 3.3	V
Supply Voltage	AVDD	DGND=AGND=0V	DVDD	V
Supply Voltage	IOVDD	DGND=AGND=0V Bus Interface	1.65-DVDD	V
Supply Voltage	IOVDD	DGND=AGND=0V Serial Interface	DVDD	V
Operating Temperature	TOP	-	-20 - +85	°C
Master clock frequency	fCLK	-	2.7 - 34	MHz



**BLOCK DIAGRAM**

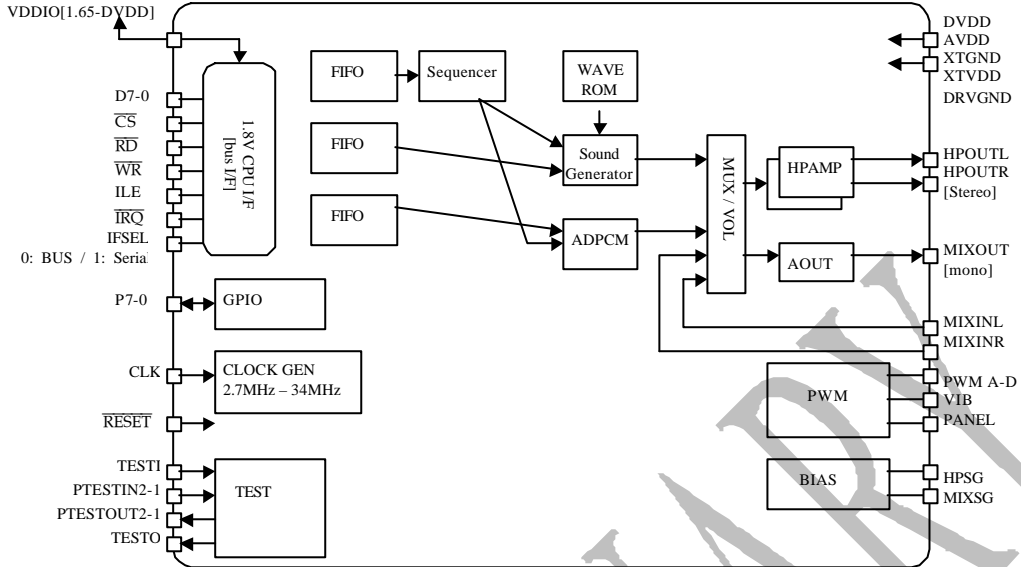

**TYPICAL APPLICATION CIRCUIT**

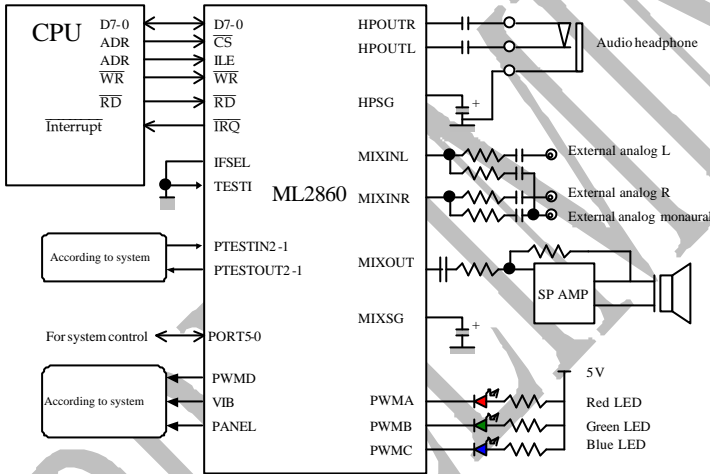

**SOFTWARE SUPPORT (SUBJECT TO AN NON DISCLOSURE AGREEMENT)**

- a.) Support software for Standard MIDI file format 0/1 playback.
- b.) Support software for MCDF (Oki original musical score format) playback.
  - MCDF: 1) File size compression of musical score from Standard MIDI file
  - 2) Expand function for synchronization between picture, text, LED and MIDI.

**DC CHARACTERISTICS [OUTLINE]**

IOVDD=1.65-DVDD, DVDD=AVDD=+2.7V-3.3V, DGND=AGND=0V, Ta=-20-+85°C

Parameter	Symbol	Condition	Min.	Typ	Max.	Unit
“H” Input Voltage	VIH	DGND=AGND=0V	VDD x 0.8	-	-	V
“L” Input Voltage	VIL	-	-	-	VDD x 0.2	V
“H” Output Voltage	VOH	IOH=-100μA	VDDx0.8	-	-	V
“L” Output Voltage	VOL	IOL=100μA	-	-	VDDx0.2	V
“H” Input Current	IiH	VIH=VDD	-	-	10	μA
“L” Input Current	IiL	VIL=0V	-10	-	-	μA
Operating Current	IDDD	Sound generator (Ports no load)	-	20	30	mA
		Stereo/f=1kHz Each drive 3mW AC-Load = 32Ω	-	18	-	mA
Standby Current	IDDS	Ta=-20-+40°C	-	1	10	μA
		Ta=+40-+50°C	-	-	20	μA
		Ta=+50-+75°C	-	-	100	μA
		Ta=+75-+85°C	-	-	150	μA

**AC CHARACTERISTICS / TIMING CHART [OUTLINE]**

IOVDD=1.65V- DVDD, DVDD=+2.7V-3.3V, DGND=AGND=0V, Ta=-20-+85°C

**BUS WRITE TIMING**

Parameter	Symbol	Min	Max.	Unit
ILE valid to Write Enable Low	tIWL	10		ns
ILE valid to Write Enable High	tIWH	10		ns
CSB valid to Write Enable Low	tCWL	5		ns
Write Enable Pulse Width	tWW	25		ns
Data Valid to Write Enable Low	tDWL	50		ns
Data Valid to Write Enable High	tDWH	0		ns
Chip Select to End of Write	tCEW	50		ns

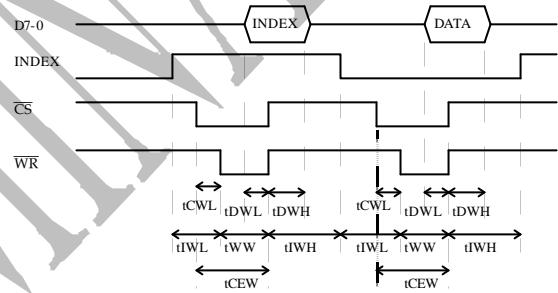

**BUS READ TIMING**

Parameter	Symbol	Min	Max.	Unit
ILE valid to Read Enable Low	TIRL	10	-	ns
ILE valid to Read Enable High	TIRH	10	-	ns
Read Enable Low to Data Valid	TRLDV	-	85	ns
Chip Enable Low to Data Valid	TCLDV	-	85	ns
Read Enable High to Data Transition	TRHDT	-	85	ns
Chip Enable High to Data Transition	TCHDT	-	85	ns

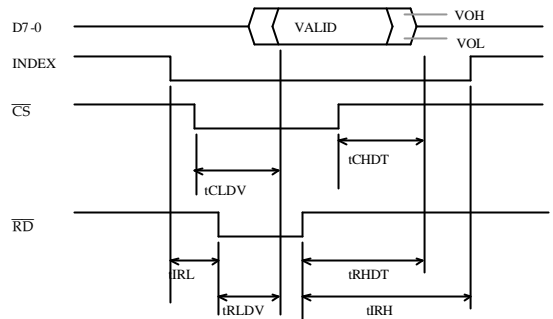

SERIAL INTERFACE

DVDD =IOVDD =+2.7V-3.3V, DGND=AGND=0V, Ta=-20-+85°C

Parameter	Symbol	Min	Max.	Unit
Chip Select Low to SCLK Low 1	tCLSL1	50	-	ns
Chip Select Low to SCLK Low 2	tCLSL2	25	-	ns
Chip Select Low to SCLK High 1	tCLSH1	50	-	ns
Chip Select Low to SCLK High 2	tCLSH2	25	-	ns
SCLK High Pulse Width	tSH	25	-	ns
SCLK Low Pulse Width	tSL	25	-	ns
SCLK Cycle Time	tSC	50	-	ns
Input Data Valid to SCLK Low1	tIDSL1	15	-	ns
Input Data Valid to SCLK Low2	tIDSL2	15	-	ns
Input Data Valid to SCLK High1	tIDSH1	15	-	ns
Input Data Valid to SCLK High2	tIDSH2	15	-	ns
Chip Select High to SCLK Low 1	tCHSL1	0	-	ns
Chip Select High to SCLK High 2	tCHSH2	0	-	ns
Chip Select High Pulse Width	tCH	25	-	ns
Output Data Valid to SCLK Low 1	tODSL1	-	20	ns
Output Data Valid to SCLK High 2	tODSH2	-	20	ns
Chip Enable High to Data Transition	tCHDT	-	20	ns
RST High to Chip Select Low	tRSC	90	-	ns
RST Pulse Width	tRST	1	-	μs
Initialize Time	tINIT	-	40	ms

DATA Write Timing

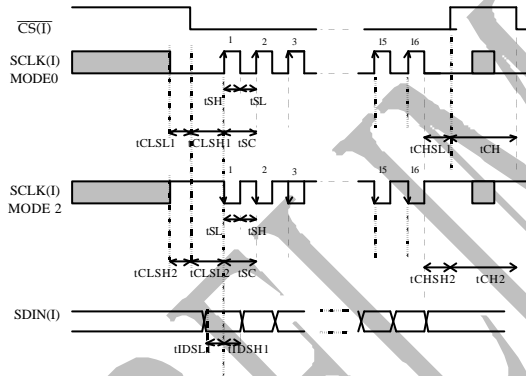

Data Read Timing

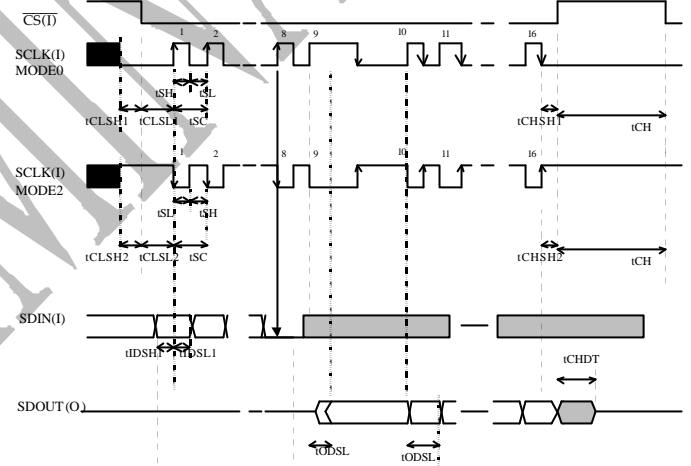

FREQUENTLY ASKED QUESTIONS

- Q1. What kind of musical score formats does the ML2860 support?  
 A1. ML2860 can play Standard MIDI files under given conditions and the Oki original musical score format directly. If Standard MIDI file format 1/0 or Karaoke function need to be supported, Oki provides sample software based on NDA for this purpose.
- Q2. What is the condition for playing Standard MIDI file directly?  
 A2.  
 (1) Play format 0 only, do not play format 1.  
 (2) Eliminate text and MIDI events not supported by the ML2860.
- Q3. Which MIDI events does the ML2860 support?  
 A3.  
 - Note On/Off / Program change / Pitch bend / Channel pressure  
 - Control change [Modulation / Volume / Pan / Expression / Sustain / Reset all controller / All note off]  
 - RPN [Pitch bend sensitivity / Fine tuning / Coarse tuning]
- Q4. Does the ML2860 support synchronization of LED with ADPCM playback ?  
 A4. Yes. LED and ADPCM functions are included in the musical score and are assigned as percussion to MIDI channel 10. It is necessary to build a software routine for this synchronization.