

# Bi-directional Sensorless BLDC Motor Controller

## GENERAL DESCRIPTION

The ML4426 PWM motor controller provides all of the functions necessary for starting and controlling the speed of delta or wye wound Brushless DC (BLDC) motors without Hall Effect sensors. Back EMF voltage is sensed from the motor windings to determine the proper commutation phase sequence using a PLL. This patented sensing technique will commutate a wide range of 3-Phase BLDC motors and is insensitive to PWM noise and motor snubbing circuitry.

The ML4426 limits the motor current using a constant off-time PWM control loop. The velocity loop is controlled with an onboard amplifier. The ML4426 has circuitry to ensure that there is no shoot-through in directly driven external power MOSFETs.

The timing of the start-up sequence is determined by the selection of three timing capacitors. This allows optimization for a wide range of motors and loads.

## FEATURES

- Motor starts and stops with power to IC
- Bi-directional motor drive for applications requiring forward/reverse operation
- On-board start sequence: Align → Ramp → Set Speed
- Patented Back-EMF commutation technique provides jitterless torque for minimum "spin-up" time
- Onboard speed control loop
- PLL used for commutation provides noise immunity from PWM spikes, compared to noise sensitive zero crossing technique
- PWM control for maximum efficiency
- Direct FET drive for 12V motors; drives high voltage motors with IC buffers from IR, IXYS, Harris, Power Integrations, Siliconix, etc.

(\* Indicates Part Is End Of Life As Of July 1, 2000)

## BLOCK DIAGRAM (Pin Configuration Shown for 28 Pin Version)

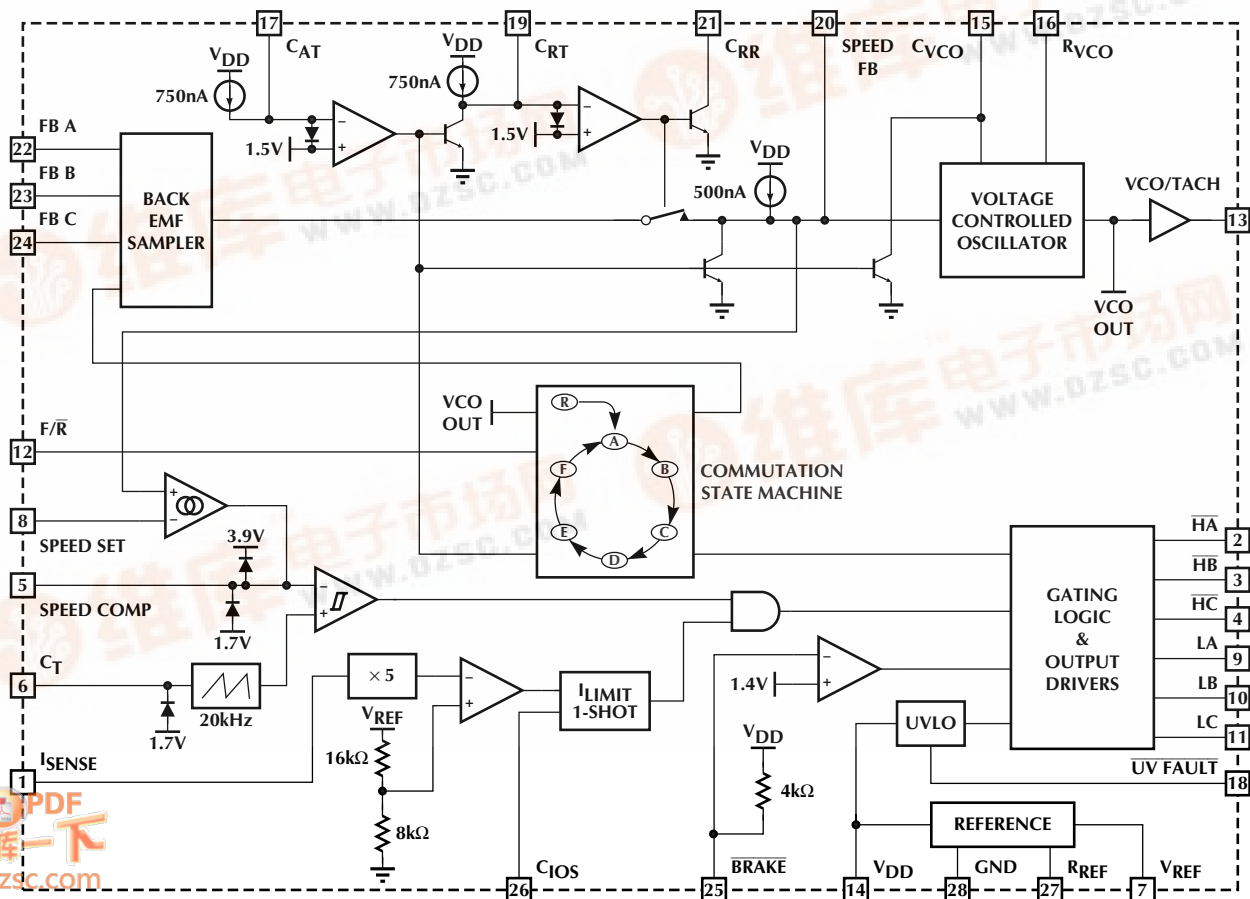

# ML4426

## PIN CONFIGURATION

**ML4426**  
28-Pin Narrow PDIP (P28N)  
28-Pin SOIC (S28)

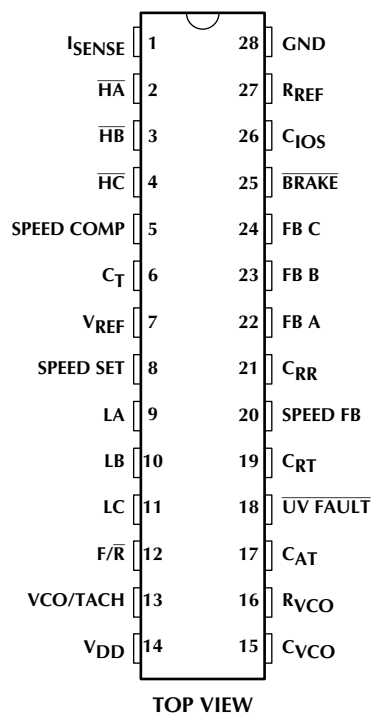

**ML4425**  
32-Pin TQFP (H32-7)

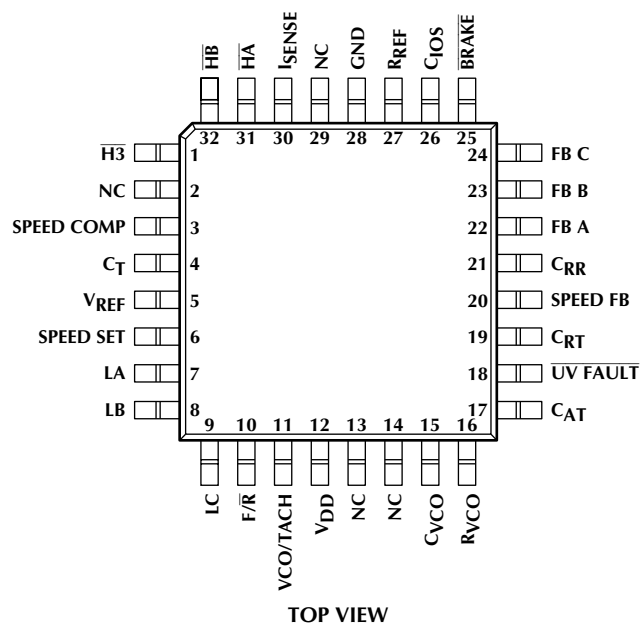

**PIN DESCRIPTION** (Pin number in parenthesis is for TQFP package)

| PIN    | NAME               | FUNCTION                                                                                                                                                                                                              | PIN    | NAME                   | FUNCTION                                                                                                                                                                                                                     |
|--------|--------------------|-----------------------------------------------------------------------------------------------------------------------------------------------------------------------------------------------------------------------|--------|------------------------|------------------------------------------------------------------------------------------------------------------------------------------------------------------------------------------------------------------------------|
| 1(30)  | I <sub>SENSE</sub> | Motor current sense input. When I <sub>SENSE</sub> exceeds $0.2 \times I_{LIMIT}$ , the output drivers LA, LB, and LC are shut off for a fixed time determined by C <sub>IOS</sub>                                    | 17(17) | C <sub>AT</sub>        | A capacitor to GND sets the time that the controller stays in the align mode                                                                                                                                                 |
| 2(31)  | $\overline{HA}$    | Active low output driver for the phase A high-side switch                                                                                                                                                             | 18(18) | $\overline{UV\ FAULT}$ | This output goes low when V <sub>DD</sub> drops below the UVLO threshold, and indicates that all output drivers have been disabled                                                                                           |
| 3(32)  | $\overline{HB}$    | Active low output driver for the phase B high-side switch                                                                                                                                                             | 19(19) | C <sub>RT</sub>        | A capacitor to GND sets the time that the controller stays in the ramp mode                                                                                                                                                  |
| 4(1)   | $\overline{HC}$    | Active low output driver for the phase C high-side switch                                                                                                                                                             | 20(20) | SPEED FB               | Output of the back-EMF sampling circuit and input to the VCO. An RC network connected to SPEED FB sets the compensation for the PLL loop formed by the back-EMF sampling circuit, the VCO, and the commutation state machine |
| 5(3)   | SPEED COMP         | Speed control loop compensation is set by a series resistor and capacitor from SPEED COMP to GND                                                                                                                      | 21(21) | C <sub>RR</sub>        | A capacitor to between C <sub>RR</sub> and SPEED FB sets the ramp rate (acceleration) of the motor when the controller is in ramp mode                                                                                       |
| 6(4)   | C <sub>T</sub>     | A capacitor from C <sub>T</sub> to GND sets the PWM oscillator frequency                                                                                                                                              | 22(22) | FB A                   | The motor feedback voltage from phase A is monitored through a resistor divider for back-EMF sensing at this pin                                                                                                             |
| 7(5)   | V <sub>REF</sub>   | 6.9V reference voltage output                                                                                                                                                                                         | 23(23) | FB B                   | The motor feedback voltage from phase B is monitored through a resistor divider for back-EMF sensing at this pin                                                                                                             |
| 8(6)   | SPEED SET          | Speed loop input which ranges from 0 (stopped) to V <sub>REF</sub> (maximum speed)                                                                                                                                    | 24(24) | FB C                   | The motor feedback voltage from phase C is monitored through a resistor divider for back-EMF sensing at this pin                                                                                                             |
| 9(7)   | LA                 | Active high output driver for the phase A low-side switch                                                                                                                                                             | 25(25) | $\overline{BRAKE}$     | A logic low input activates motor braking by shutting off the high-side output drivers and turning on the low-side output drivers                                                                                            |
| 10(8)  | LB                 | Active high output driver for the phase B low-side switch                                                                                                                                                             | 26(26) | C <sub>IOS</sub>       | A capacitor to GND sets the time that the low-side output drivers remain off after I <sub>SENSE</sub> exceeds its threshold                                                                                                  |
| 11(9)  | LC                 | Active high output driver for the phase C low-side switch                                                                                                                                                             | 27(27) | R <sub>REF</sub>       | An 137kΩ resistor to GND sets a current proportional to V <sub>REF</sub> that is used to set all the internal bias currents except for the VCO                                                                               |
| 12(10) | $\overline{F/R}$   | This TTL level input selects the direction of the motor by changing the sequence of the commutation state machine                                                                                                     | 28(28) | GND                    | Signal and power ground                                                                                                                                                                                                      |
| 13(11) | VCO/TACH           | This TTL level output corresponds to the signal used to clock the commutation state machine. The output frequency is proportional to the motor speed when the back-EMF sensing loop is locked onto the rotor position |        |                        |                                                                                                                                                                                                                              |
| 14(12) | V <sub>DD</sub>    | 12V power supply input                                                                                                                                                                                                |        |                        |                                                                                                                                                                                                                              |
| 15(15) | C <sub>VCO</sub>   | A capacitor to GND sets the voltage-to-frequency ratio of the VCO                                                                                                                                                     |        |                        |                                                                                                                                                                                                                              |
| 16(16) | R <sub>VCO</sub>   | An resistor to GND sets up a current proportional to the input voltage of the VCO                                                                                                                                     |        |                        |                                                                                                                                                                                                                              |

# ML4426

## ABSOLUTE MAXIMUM RATINGS

Absolute maximum ratings are those values beyond which the device could be permanently damaged. Absolute maximum ratings are stress ratings only and functional device operation is not implied.

|                                               |                                     |
|-----------------------------------------------|-------------------------------------|
| V <sub>DD</sub> .....                         | 14V                                 |
| Logic Inputs (BRAKE, F/R) .....               | GND - 0.3 to 7V                     |
| All Other Inputs and Outputs ..               | GND -0.3V to V <sub>DD</sub> + 0.3V |
| Output Current (LA, LB, LC, HA, HB, HC) ..... | ±50mA                               |
| Junction Temperature .....                    | 150°C                               |
| Storage Temperature Range .....               | -65°C to 150°C                      |
| Lead Temperature (Soldering 10 sec.) .....    | 260°C                               |

|                                       |        |
|---------------------------------------|--------|
| Thermal Resistance (θ <sub>JA</sub> ) |        |
| 28-Pin Narrow PDIP .....              | 48°C/W |
| 28-Pin SOIC .....                     | 75°C/W |
| 32-Pin TQFP .....                     | 80°C/W |

## OPERATING CONDITIONS

|                       |                |
|-----------------------|----------------|
| Temperature Range     |                |
| ML4426CX .....        | 0°C to 70°C    |
| ML4426IX .....        | -40°C to 85°C  |
| V <sub>DD</sub> ..... | 10.8V to 13.2V |

## ELECTRICAL CHARACTERISTICS

Unless otherwise specified, V<sub>DD</sub> = 12V ± 10%, R<sub>SENSE</sub> = 1Ω, C<sub>VCO</sub> = 10nF, C<sub>IOS</sub> = 100pF, R<sub>REF</sub> = 137kΩ, T<sub>A</sub> = Operating Temperature Range (Notes 1, 2)

| SYMBOL                               | PARAMETER                            | CONDITIONS                                              | MIN      | TYP  | MAX              | UNITS |    |
|--------------------------------------|--------------------------------------|---------------------------------------------------------|----------|------|------------------|-------|----|
| <b>REFERENCE</b>                     |                                      |                                                         |          |      |                  |       |    |
| V <sub>REF</sub>                     | Total Variation                      | Line, Temp                                              | 6.5      | 6.9  | 7.5              | V     |    |
| <b>PWM OSCILLATOR</b>                |                                      |                                                         |          |      |                  |       |    |
|                                      | Total Variation                      | C <sub>T</sub> = 1nF                                    |          | 28   |                  | kHz   |    |
|                                      | Ramp Peak                            |                                                         |          | 3.9  |                  | V     |    |
|                                      | Ramp Valley                          |                                                         |          | 1.7  |                  | V     |    |
|                                      | Ramp Charging Current                |                                                         |          | ?    |                  | μA    |    |
| <b>SPEED CONTROL LOOP</b>            |                                      |                                                         |          |      |                  |       |    |
|                                      | SPEED SET Input Voltage Range        |                                                         | 0        |      | V <sub>REF</sub> | V     |    |
|                                      | SPEED FB Input Voltage Range         |                                                         | 0        |      | V <sub>REF</sub> | V     |    |
|                                      | SPEED COMP Output Current            |                                                         | ±5       |      | ±20              | μA    |    |
|                                      | SPEED SET Error Amp Transconductance | V <sub>SPEED SET</sub> = xV, V <sub>SPEED FB</sub> = yV |          | 144  |                  | μΩ    |    |
| <b>START-UP</b>                      |                                      |                                                         |          |      |                  |       |    |
| C <sub>AT</sub> Charging Current     |                                      | C Suffix                                                | 0.68     |      | 0.98             | μA    |    |
|                                      |                                      | I Suffix                                                | 0.5      |      | 1.1              | μA    |    |
| C <sub>AT</sub> Threshold Voltage    |                                      |                                                         | 1.4      |      | 1.7              | V     |    |
| C <sub>RT</sub> Charging Current     |                                      | C Suffix                                                | 0.68     |      | 0.98             | μA    |    |
|                                      |                                      | I Suffix                                                | 0.5      |      | 1.1              | μA    |    |
| C <sub>RT</sub> Threshold Voltage    |                                      |                                                         | 1.4      |      | 1.7              | V     |    |
| <b>VOLTAGE CONTROLLED OSCILLATOR</b> |                                      |                                                         |          |      |                  |       |    |
|                                      | Frequency Range                      | R <sub>VCO</sub> = 5V, SPEED FB = 6V                    | 1.5      | 1.85 | 2.2              | kHz   |    |
|                                      | Frequency vs. SPEED FB               | R <sub>VCO</sub> = 5V, 0.5V ≤ SPEED FB ≤ 7V             |          | 300  |                  | Hz/V  |    |
| <b>CURRENT LIMIT</b>                 |                                      |                                                         |          |      |                  |       |    |
| I <sub>SENSE</sub> Gain              |                                      |                                                         | 4.5      | 5.0  | 5.5              | V/V   |    |
| One Shot OFF-Time                    |                                      | C <sub>IOS</sub> = 100pF                                | C Suffix | 9    |                  | 18    | μs |
|                                      |                                      |                                                         | I Suffix | 9    |                  | 20    | μs |

**ELECTRICAL CHARACTERISTICS** (Continued)

| SYMBOL                                             | PARAMETER                                  | CONDITIONS                                                                | MIN                   | TYP                   | MAX | UNITS |    |
|----------------------------------------------------|--------------------------------------------|---------------------------------------------------------------------------|-----------------------|-----------------------|-----|-------|----|
| <b>LOGIC INPUTS (BRAKE, F/R) (Note 3)</b>          |                                            |                                                                           |                       |                       |     |       |    |
| V <sub>IH</sub>                                    | Input High Voltage                         |                                                                           | 2                     |                       |     | V     |    |
| V <sub>IL</sub>                                    | Input Low Voltage                          |                                                                           |                       |                       | 0.8 | V     |    |
| I <sub>IH</sub>                                    | Input High Current                         | V <sub>IH</sub> = 2.4V                                                    |                       | 2.4                   |     | mA    |    |
| I <sub>IL</sub>                                    | Input Low Current                          | V <sub>IL</sub> = 0.4V                                                    |                       | 2.9                   |     | mA    |    |
| <b>LOGIC OUTPUTS (VCO/TACH, UV FAULT) (Note 3)</b> |                                            |                                                                           |                       |                       |     |       |    |
|                                                    | VCO/TACH Output High Voltage               | I <sub>OUT</sub> = -100μA                                                 | 2.2                   |                       |     | V     |    |
|                                                    | VCO/TACH Output Low Voltage                | I <sub>OUT</sub> = 400μA                                                  |                       |                       | 0.6 | V     |    |
|                                                    | UV FAULT Output High Voltage               | I <sub>OUT</sub> = -10μA                                                  | C Suffix              | 3.4                   | 4.5 | 5.4   | V  |
|                                                    |                                            |                                                                           | I Suffix              | 3.2                   |     | 5.6   | V  |
|                                                    | UV FAULT Output Low Voltage                | I <sub>OUT</sub> = 400μA                                                  |                       |                       | 0.6 | V     |    |
| <b>BACK-EMF SAMPLER</b>                            |                                            |                                                                           |                       |                       |     |       |    |
|                                                    | SPEED FB Align Mode Voltage                |                                                                           |                       | 125                   | 250 | mV    |    |
|                                                    | SPEED FB Ramp Mode Current                 |                                                                           | C Suffix              | 500                   |     | 720   | nA |
|                                                    |                                            |                                                                           | I Suffix              | 500                   |     | 750   | nA |
|                                                    | SPEED FB Run Mode Current                  | State A, C <sub>RT</sub> = 5V,<br>V <sub>PHB</sub> = V <sub>DD</sub> /3   | C Suffix              | 30                    |     | 90    | μA |
|                                                    |                                            |                                                                           | I Suffix              | 27                    |     | 90    | μA |
|                                                    |                                            | State A, C <sub>RT</sub> = 5V, V <sub>PHB</sub> = V <sub>DD</sub> /2      |                       | -15                   |     | 15    | μA |
|                                                    |                                            | State A, C <sub>RT</sub> = 5V,<br>V <sub>PHB</sub> = 2×V <sub>DD</sub> /3 | C Suffix              | -90                   |     | -30   | μA |
|                                                    |                                            |                                                                           | I Suffix              | -90                   |     | -27   | μA |
| <b>OUTPUT DRIVERS</b>                              |                                            |                                                                           |                       |                       |     |       |    |
|                                                    | High Side Driver Output Low Current        | V <sub>HX</sub> = 2V                                                      | 0.5                   |                       | 1.2 | mA    |    |
|                                                    | High Side Driver Output High Voltage       | I <sub>HX</sub> = -10μA                                                   | V <sub>CC</sub> - 1.3 |                       |     | V     |    |
|                                                    | Low Side Driver Output Low Voltage         | I <sub>LX</sub> = 1mA                                                     |                       | 0.2                   | 0.7 | V     |    |
|                                                    | Low Side Driver Output High Voltage        | V(I <sub>SENSE</sub> ) = 0V                                               | C Suffix              | V <sub>DD</sub> - 2.2 |     | V     |    |
|                                                    |                                            |                                                                           | I Suffix              | V <sub>DD</sub> - 2.9 |     | V     |    |
|                                                    | Phase C Cross-conduction Lockout Threshold |                                                                           |                       | V <sub>DD</sub> - 3.0 |     | V     |    |
| <b>SUPPLY</b>                                      |                                            |                                                                           |                       |                       |     |       |    |
| I <sub>DD</sub>                                    | V <sub>DD</sub> Current                    |                                                                           |                       | 32                    | 50  | mA    |    |
|                                                    | UVLO Threshold                             |                                                                           | C Suffix              | 8.8                   | 9.5 | 10.2  | V  |
|                                                    |                                            |                                                                           | I Suffix              | 8.6                   |     | 10.3  | V  |
|                                                    | UVLO Hysteresis                            |                                                                           |                       | 150                   |     | mV    |    |

**Note 1:** Limits are guaranteed by 100% testing, sampling, or correlation with worst case test conditions.

**Note 2:** For explanation of states, see Figure 4 and Table 1.

**Note 3:** The BRAKE and UV FAULT pins each have an internal 4kΩ resistor to the internal reference.

# ML4426

## FUNCTIONAL DESCRIPTION

### GENERAL

The ML4426 provides all the circuitry for sensorless speed control of 3-phase Brushless DC (BLDC) motors. Controller functions include start-up circuitry, back-EMF commutation control, Pulse Width Modulation (PWM) speed control, fixed OFF-time current limiting, braking, and undervoltage protection.

The start-up circuitry aligns the motor to a known position, then ramps up the motor speed to generate a back-EMF signal. A back-EMF sampling circuit controls commutation timing by forming a Phase Locked Loop (PLL). The commutation control circuitry also outputs a speed feedback (SPEED FB) signal used in the speed control loop. The speed control loop consists of an error amplifier and PWM comparator that produce a PWM duty cycle for speed regulation. Motor current is limited by a fixed OFF-time PWM shutdown comparator that is controlled by an external sense resistor. Commutation control, PWM speed control, and current limiting are combined to produce the output driver signals. Six output drivers are used to provide gating signals to an external 3 phase bridge power stage sized for the BLDC motor voltage and current requirements. Additional functions include a braking function and undervoltage protection circuit to shut down the output drivers in the event of a low voltage condition on  $V_{DD}$  of the ML4426.

### COMPONENT SELECTION

Selecting external components for the ML4426 requires calculations based on the motor's electrical and mechanical parameters. The following is a list of the motor parameters needed for these calculations :

- DC motor supply voltage –  $V_{MOTOR}$  (V)
- Maximum operating current –  $I_{MAX}$  (A)
- Number of magnetic poles – N
- Back EMF constant –  $K_e$  (V-s/Rad)
- Motor torque constant –  $K_t$  (Nm/A) ( $K_t = K_e$  in SI units)
- Maximum speed of operation  $RPM_{MAX}$  (RPM)
- Moment of inertia of the motor and load – J (Kg-m<sup>2</sup>)
- Viscous damping factor of the motor and load –  $\zeta$

If one or more of the above values is not known, it is still possible to pick components for the ML4426, but some experimentation may be necessary to determine the optimal values. All quantities are in SI units unless otherwise specified. The following formulas should be considered as a starting point for optimization. All calculations for capacitors and resistors should be used as the first approximation for selecting the closest standard value.

### POWER SUPPLY AND REFERENCE

The supply voltage ( $V_{DD}$ ) is nominally 12V  $\pm$ 10%. A 100nF bypass capacitor to ground should be placed as close as possible to  $V_{DD}$ . A 6.9V voltage reference output ( $V_{REF}$ ) is provided to set the speed command and current limit of the ML4426. A 137k $\Omega$  from  $R_{REF}$  to GND is required to set up a reference current for internal functions.

### OUTPUT DRIVERS

The output drivers LA, LB, LC,  $\overline{HA}$ ,  $\overline{HB}$ , and  $\overline{HC}$  provide totem pole output drive signals for a 3 phase bridge power stage. All control functions in the ML4426 translate to outputs at these pins. LA, LB, and LC provide the low-side drive signals for phases A, B, and C of the 3 phase power stage and are 12V active high signals.  $\overline{HA}$ ,  $\overline{HB}$ , and  $\overline{HC}$  provide the high-side signals and are 12V active low signals.

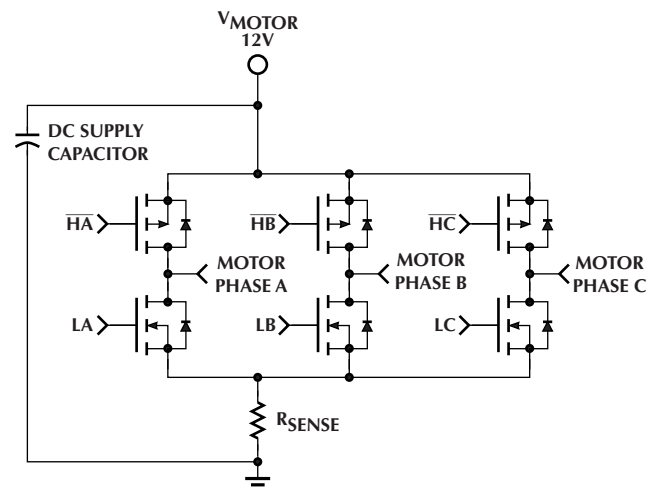

Figure 1. Using  $R_{SENSE}$  in a 3-Phase 12V Power Stage

**FUNCTIONAL DESCRIPTION** (Continued)

**CURRENT LIMITING IN THE POWER STAGE**

The current sense resistor ( $R_{SENSE}$ ) shown in Figure 1 regulates the maximum current in the power stage and the BLDC motor. Current regulation is accomplished by shutting off the output drivers LA, LB, and LC for a fixed amount of time if the voltage across  $R_{SENSE}$  exceeds the current limit threshold.

**$R_{SENSE}$**

The function of  $R_{SENSE}$  is to provide a voltage proportional to the motor current to set the current limit trip point. The default trip voltage across  $R_{SENSE}$  is 460mV, set by the internal  $I_{LIMIT}$  divider ratio. The current sense resistor should be a low inductance resistor such as a carbon composition. For resistors in the milliohms range, wire-wound resistors tend to have low values of inductance.  $R_{SENSE}$  should be sized to handle the power dissipation ( $I_{MAX}^2 \times R_{SENSE}$ ).

**$I_{SENSE}$  Filter**

The  $I_{SENSE}$  RC lowpass filter is placed in series with the current sense signal as shown in Figure 2. The purpose of this filter is to remove the diode reverse recovery shootthrough current. This current causes a voltage spike on the leading edge of the current sense signal which may falsely trigger the current limit. The current sense voltage waveform is shown before and after filtering in Figure 3. The recommended starting values for this circuit are  $R = 1k\Omega$  and  $C = 330pF$ . This gives a time constant of 330ns, and will filter out spikes of shorter duration. C can be increased to as much as 2.2nF, but should not exceed a time constant of more than a few microseconds.

**$C_{IOS}$**

When  $I_{SENSE}$  exceeds  $0.2 \times I_{LIMIT}$ , the current limit one-shot is activated, turning off LA, LB, and LC for a fixed amount of time ( $t_{OFF}$ ).  $t_{OFF}$  is set by the amount of capacitance connected to  $C_{IOS}$ .  $C_{IOS}$  is usually set for a fixed off time equal to or less than the PWM period. For a 25kHz PWM frequency, the PWM period is 40µs;  $t_{OFF}$  should be between 20µs and 40µs. The lower limit of  $t_{OFF}$  is dictated by the minimum on time of the power stage; a safe approximation is 5µs or less. The equation for finding the  $C_{IOS}$  capacitance value is as follows:

$$C_{OS} = \frac{t_{OFF} \times 50\mu A}{2.4V} \quad (1)$$

**COMMUTATION CONTROL**

A 3-phase BLDC motor requires electronic commutation to achieve rotational motion. Electronic commutation requires the switching on and off of the power switches of a 3-phase half bridge. For torque production to be achieved in one direction, the commutation is dictated by the rotor position. Electronic commutation in the ML4426 is achieved by turning on and off, in the proper sequence,

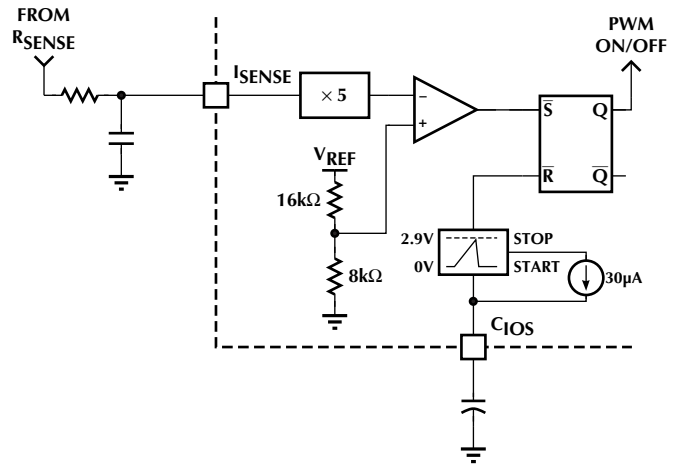

Figure 2. Current Sense Circuitry

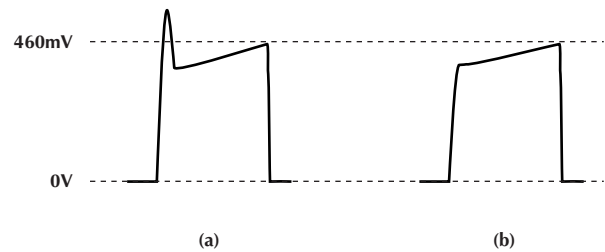

Figure 3. Current Sense Resistor Waveforms (a) Without Filtering, and (b) With Filtering

one N output from one phase and one P output from another phase. There are six combinations of N and P outputs (six switching states) that constitute a full commutation cycle. These combinations are illustrated in Table 1 and Figure 4, and are labeled states A through F. This sequence is programmed into the commutation state machine. Clocking of the commutation state machine is provided by a voltage controlled oscillator (VCO).

**Forward/Reverse Control**

The commutation sequence is reversed by pulling the  $F/\bar{R}$  pin to GND. This allows the motor to operate in the opposite direction. This pin should change state only when the motor is at rest. Either remove and restore power to the ML4426, or pull the  $\bar{BRAKE}$  pin and  $C_{AT}$  pin to 0V to stop the motor prior to changing the voltage on  $F/\bar{R}$ . Either method resets the internal commutation state machine, and initiates a new start-up sequence.

# ML4426

| STATE | OUTPUTS |     |     |     |     |     | INPUT SAMPLING |
|-------|---------|-----|-----|-----|-----|-----|----------------|
|       | LA      | LB  | LC  | HA  | HB  | HC  |                |
| R     | OFF     | ON  | OFF | ON  | OFF | ON  | N/A            |
| A     | OFF     | OFF | ON  | ON  | OFF | OFF | FB B           |
| B     | OFF     | OFF | ON  | OFF | ON  | OFF | FB A           |
| C     | ON      | OFF | OFF | OFF | ON  | OFF | FB C           |
| D     | ON      | OFF | OFF | OFF | OFF | ON  | FB B           |
| E     | OFF     | ON  | OFF | OFF | OFF | ON  | FB A           |
| F     | OFF     | ON  | OFF | ON  | OFF | OFF | FB C           |

Table 1. Commutation State Functions (Forward Direction)

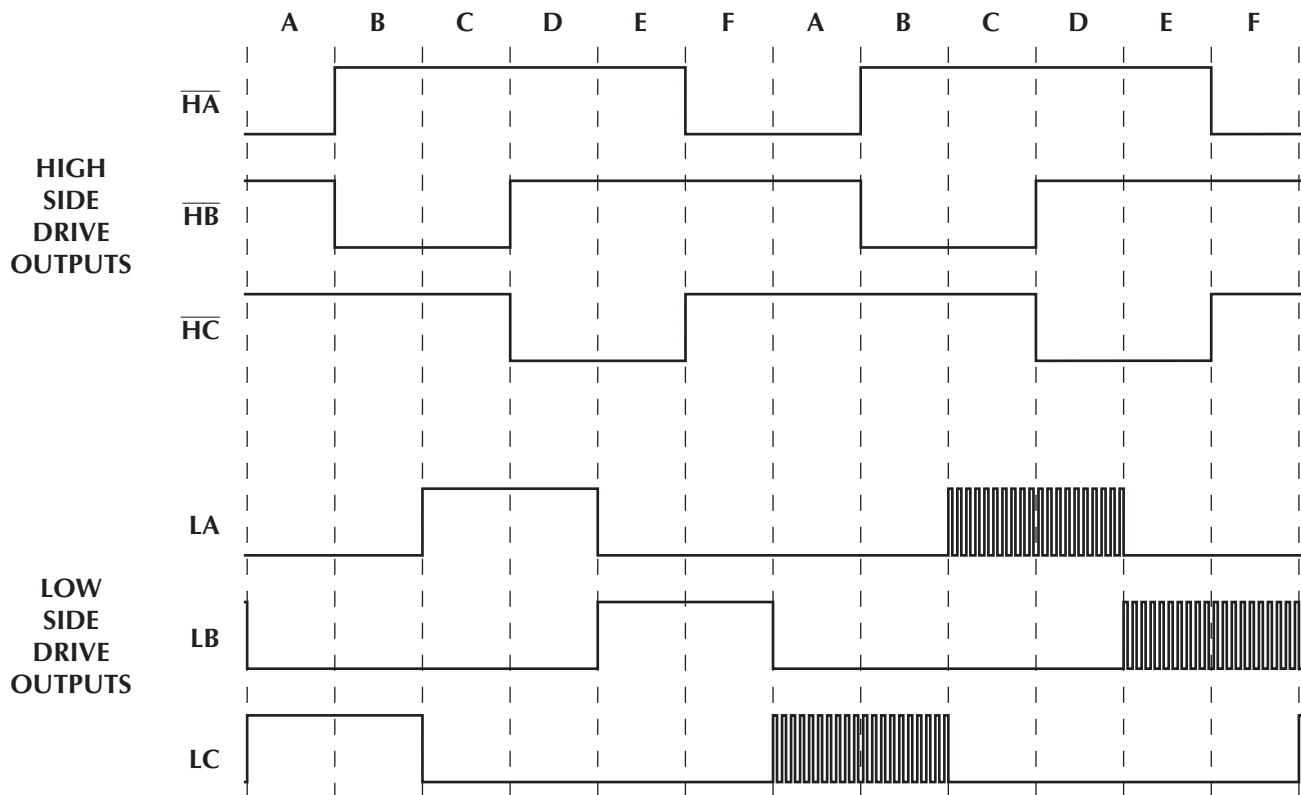

Figure 4. Output Commutation Sequence Timing Diagram (Forward Direction)  
 Cycle 1 - Full Commutation, Cycle 2 - Commutation with 50% PWM Duty Cycle

## FUNCTIONAL DESCRIPTION (Continued)

### Voltage Controlled Oscillator (VCO)

The VCO provides a TTL compatible clock output on the VCO/TACH pin proportional to the VCO input voltage at the SPEED FB pin. The proportion of frequency to voltage (VCO constant,  $K_v$ ) is set by an 80.6k $\Omega$  resistor on  $R_{VCO}$  and a capacitor on  $C_{VCO}$  as shown in Figure 5.  $R_{VCO}$  sets up a current proportional the VCO input voltage at SPEED FB. This current is used to charge and discharge  $C_{VCO}$  between the threshold voltages of 2.3V and 4.3V. The resulting triangle wave on  $C_{VCO}$  corresponds to the clock on VCO.  $K_v$  should be set so that the VCO output

frequency corresponds to the maximum commutation frequency or maximum motor speed when the VCO input is equal to or slightly less than  $V_{REF}$ .  $C_{VCO}$  is calculated using the following equation:

$$C_{VCO} = \frac{6.5V \times 3.101 \times 10^{-6} \frac{\text{Hz} \cdot \text{Farad}}{V}}{0.05 \frac{\text{Hz}}{\text{RPM}} \times N \times \text{SPEED}_{\text{MAX}}} \quad (2)$$

The closest standard value that is equal to or less than the calculated  $C_{VCO}$  should be used.



**FUNCTIONAL DESCRIPTION** (Continued)

The maximum frequency on the VCO pin is found by:

$$f_{MAX} = 0.05 \times N \times RPM_{MAX} \quad (3)$$

The voltage at the VCO/TACH pin is equal to the rotor speed. The voltage at SPEED FB is controlled by the back EMF sampler.

**BACK EMF SAMPLER**

The input to the voltage controlled oscillator is the back EMF sampler. The back EMF sense pins FB A, FB B, and FB C inputs to the back EMF sampler require a signal from the motor phase leads that is below the  $V_{DD}$  of the ML4426. The phase sense input impedance is  $8k\Omega$ . This requires a series resistor RES1 from the motor phase lead as shown in Figure 6 based on the following equation:

$$RES1 = 670\Omega / V \times (V_{MOTOR} - 10V) \quad (4)$$

The back EMF sampler takes the motor phase voltages divided down to signals that are less than  $V_{DD}$  (12V nominal) and calculates the neutral point of the motor by the following equation:

$$Neutral = \frac{PH1 + PH2 + PH3}{3} \quad (5)$$

This allows the ML4426 to compare the back EMF signal to the motor's neutral point without the need for bringing out an extra wire on a WYE wound motor. For DELTA wound motors there is no physical neutral to bring out, so this reference point must be calculated in any case.

The back EMF sampler measures the motor phase that is not driven (i.e. if LA and HB are on, then phase A is driven low, phase B is driven high, and phase C is

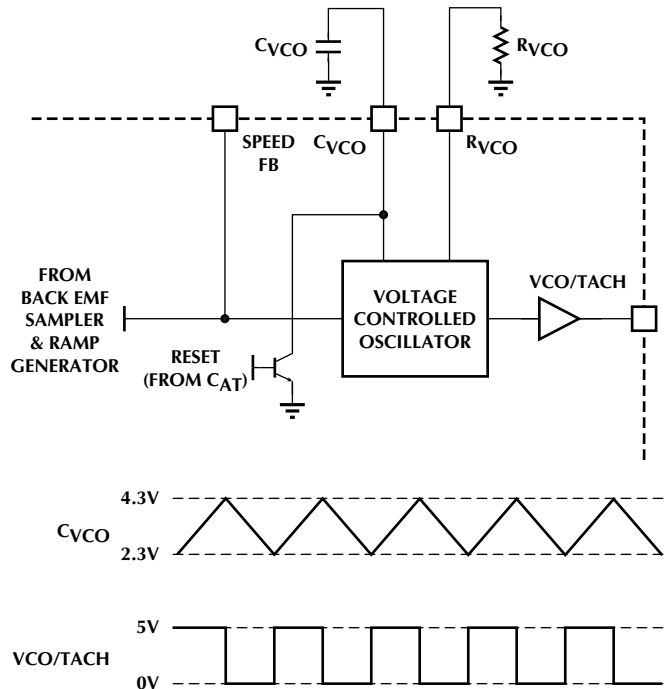

Figure 5. External VCO Component Connections

sampled). The sampled phase provides a back EMF signal that is compared against the neutral of the motor. The sampler is controlled by the commutation state machine. The sampled back EMF is compared to the neutral through an error amplifier. The output of the error amplifier outputs a charging or discharging current to SPEED FB, which provides the control voltage to the VCO.

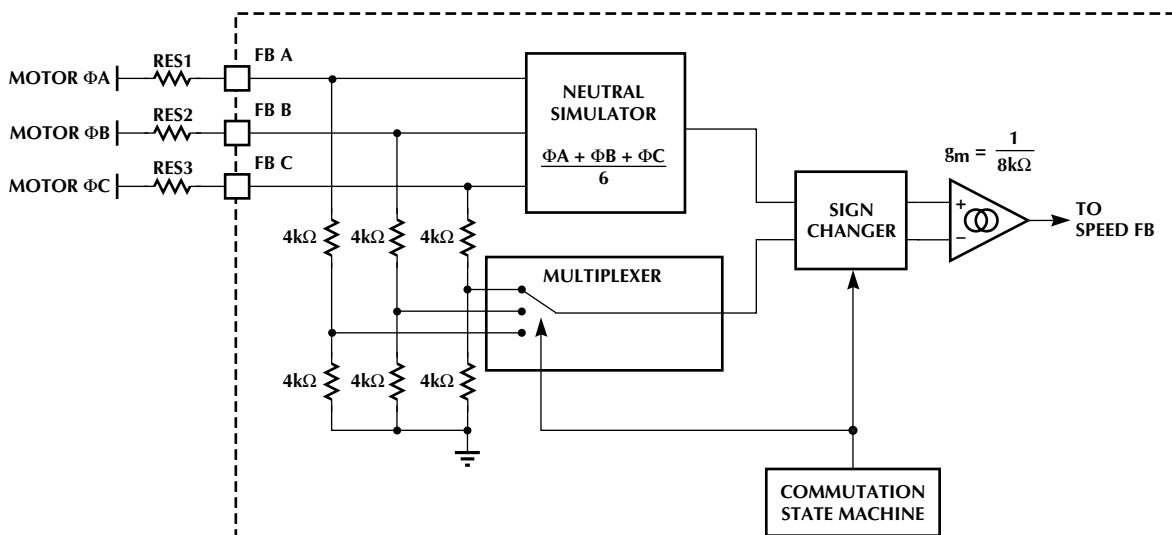

Figure 6. Back EMF Sampler Detailed Block Diagram

# ML4426

## FUNCTIONAL DESCRIPTION (Continued)

### BACK EMF SENSING PLL COMMUTATION CONTROL

Three blocks form a phase locked loop that locks the commutation clock onto the back EMF signal: the commutation state machine, the voltage controlled oscillator, and the back EMF sampler. The complete phase locked loop is illustrated in Figure 7. The phased locked loop requires a lead lag filter that is set by external components on SPEED FB. The components are selected as follows:

$$C_{\text{SPEEDFB1}} = 0.25 \times \frac{K_{O1}}{\sqrt{M}} \times \left( \frac{N_s^2}{\left( \ln\left(\frac{d}{100}\right)^2 \times f_{\text{VCO}}^2 \right)} \right) \quad (6a)$$

$$R_{\text{SPEEDFB}} = 2 \times M \times \ln\left(\frac{d}{100}\right) \times \frac{f_{\text{VCO}}}{N_s \times K_{O1} \times (1-M)} \quad (6b)$$

$$C_{\text{SPEEDFB2}} = C_{\text{SPEEDFB1}} \times (M-1) \quad (6c)$$

### START-UP SEQUENCE

When power is first applied to the ML4426 and the motor is at rest, the back EMF is equal to zero. The motor needs to be rotating for the back EMF sampler to lock onto the rotor position and commutate the motor. The ML4426 uses an open loop start-up technique to bring the rotor from rest up to a speed fast enough to allow back EMF sensing. Start-up is comprised of three modes: align mode, ramp mode, and run mode.

#### Align Mode (RESET)

Before the motor can be started, the rotor must be in a known position. When power is first applied to the ML4426, the controller is reset into the align mode. Align mode turns on the output drivers LB, HA, and HC which aligns the motor into a position 30 electrical degrees before the center of the first commutation state. This is shown as state R in the commutation states of Table 1. Align mode must last long enough to allow the motor and its load to settle into this position. The align mode time is set by a capacitor connected to the C<sub>AT</sub> pin as shown in Figure 8. C<sub>AT</sub> is charged by a constant 750μA current from GND to 1.5 V until the align comparator trips to end the align mode. A starting point for C<sub>AT</sub> is calculated as follows:

$$C_{\text{AT}} = \frac{t_s \times 7.5 \times 10^{-7} \times \text{amp}}{1.5\text{V}} \quad (7)$$

If the align time is not long enough to allow the rotor to settle for reliable starting, then increase C<sub>AT</sub> until the desired performance is achieved.

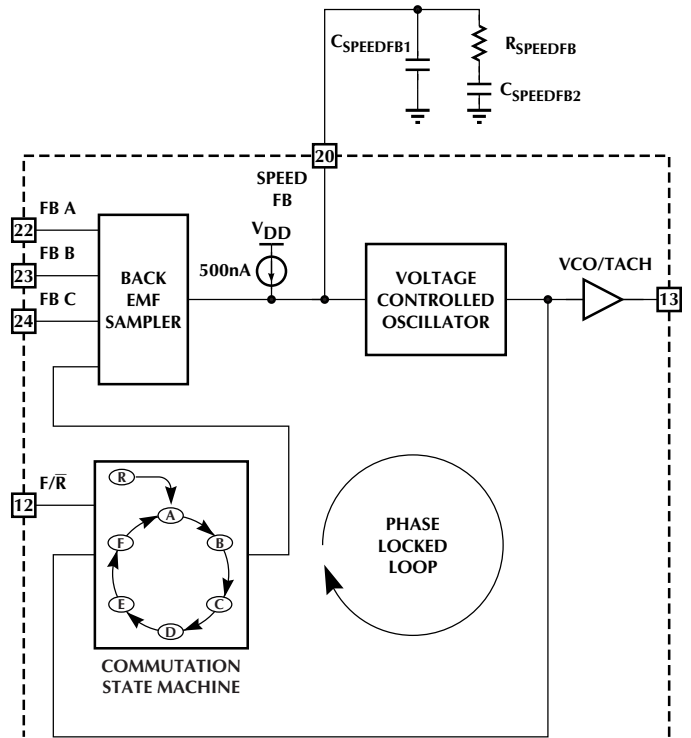

Figure 7. Back EMF Commutation Phase Locked Loop

#### Ramp Mode

At the end of align mode the controller goes into ramp mode. Ramp mode starts commutating through the states A through F as shown in Table 1. This ramps up the commutation frequency, and therefore the motor speed, for a fixed length of time. This allows the motor to reach a sufficient speed for the back EMF sampler to lock commutation onto the motor's back EMF. The amount of time the ML4426 stays in ramp mode is determined by a capacitor connected to the C<sub>RT</sub> pin as shown in Figure 8. C<sub>RT</sub> is charged by a constant 750μA current from GND to 1.5 V until the ramp comparator trips to end the ramp mode. This gives a fixed ramp time. C<sub>RT</sub> is calculated as follows:

$$C_{\text{RT}} = \frac{2\pi \times J \times 5 \times 10^{-7} \times \text{amp} \times K_V}{I_{\text{MAX}} \times K_t \times 3 \times N} \quad (8)$$

The rate at which the ML4426 ramps up the motor speed is determined by a fixed 500μA current source on the SPEED FB pin. The current source charges up the PLL filter components causing the VCO frequency to ramp up. During ramp mode, the back EMF sampler is disabled to allow control of the ramping to be set only by the 500μA current source. The ramp based on the SPEED FB filter is generally too fast for the motor to keep up, so a capacitor from C<sub>RR</sub> to SPEED FB can be added to slow down the ramping rate. The optimal ramp rate is based on the motor and load parameters and is can be adjusted by varying the value of C<sub>RR</sub>.

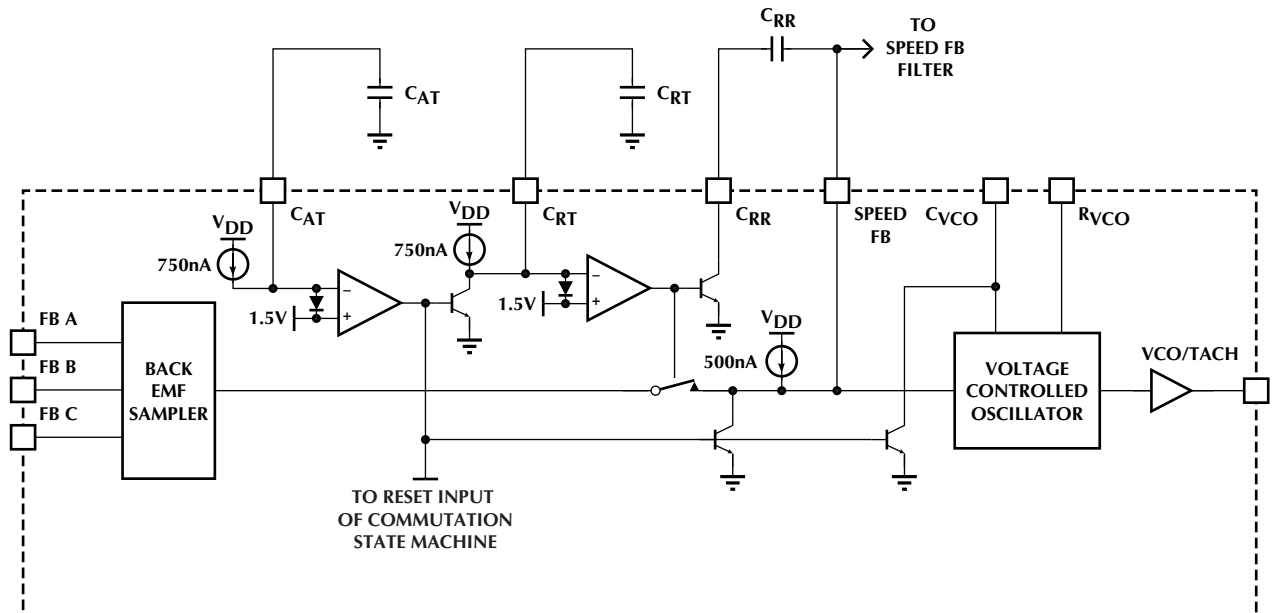

Figure 8. ML4426 Start-up Circuitry for Controlling the Align and Ramp Times

**Run Mode (Back EMF Sensing)**

At the end of ramp mode the controller goes into run mode. In run mode, the back EMF sensing is enabled and commutation is now under the control of the phase locked loop. Motor speed is now regulated by the speed control loop.

**PWM SPEED CONTROL**

Speed control is accomplished by setting a speed command at SPEED SET with an input voltage from 0 to 6.9V ( $V_{REF}$ ). The accuracy of the speed command is determined by the external components  $R_{VCO}$  and  $C_{VCO}$ . There are a number of methods that can be used to control the speed command of the ML4426. One is to use a 10kΩ potentiometer from  $V_{REF}$  to ground with the wiper connected to SPEED SET. If SPEED SET is controlled from a microcontroller, one of its DACs can be used with  $V_{REF}$  as its input reference.

The speed command is compared with the sensed speed from SPEED FB through a transconductance error amplifier. The output of the speed error amplifier is SPEED COMP. SPEED COMP is clamped between one diode drop above 3.9V (approximately 4.6V) and one diode drop below 1.7V (approximately 1V) to prevent speed loop “wind-up”. Speed loop compensation components are connected to this pin as shown in Figure 9. The speed loop compensation components are calculated as follows:

$$C_{SC} = \frac{26.9 \times N \times V_{MOTOR} \times C_{VCO}}{f_{SB} \times K_e \sqrt{2.5 + 98.696 \times \tau m^2 \times f_{SB}^2}} \quad (9a)$$

$$R_{SC} = \frac{10}{2\pi \times f_{SB} \times C_{SC}} \quad (9b)$$

Where  $f_{SB}$  is the speed loop bandwidth in Hz.

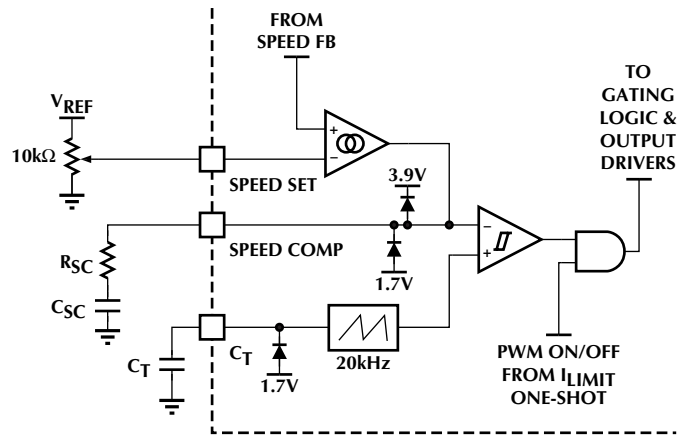

Figure 9. Speed Control Loop Component Connections

The voltage on SPEED COMP is compared with a ramp oscillator to create a PWM duty cycle. The PWM ramp oscillator creates a sawtooth function from 1.7V to 3.9V as shown in Figure 9. A negative clamp at one diode drop below 1.7V (approximately 1V) starts the oscillator on power up. The frequency of the ramp oscillator is set by a capacitor to ground  $C_{IOS}$  and is selected using the following equation:

$$C_T = \frac{1}{f_{PWM}} \times 50\mu A \quad (10)$$

Where  $f_{PWM}$  is the PWM frequency in Hz. The PWM duty cycle from the speed control loop is gated the current limit one shot that controls the LA, LB, and LC output drivers.

# ML4426

## FUNCTIONAL DESCRIPTION (Continued)

### CROSS CONDUCTION COMPARATOR

When the ML4426 goes from align mode into ramp mode, there is a possibility of cross conduction in phase 3 of the bridge power stage. This cross conduction can happen when  $\overline{HC}$  is on in the align mode shown as state R in Table 1, and the controller transitions to state A in ramp mode where  $\overline{HC}$  is turned off and LC is turned on. Cross conduction can appear due to the differences in turn on and turn off times of the power devices. To solve this problem, the LC output driver is gated off until the  $\overline{HC}$  is equal to  $V_{DD} - 3V$  as shown in Figure 10.

### BRAKING

When the  $\overline{BRAKE}$  pin is pulled below 1.4V, the low side output drivers LA, LB, and LC are turned on and the high side output drivers HA, HB, HC are turned off. Braking causes rapid deceleration of the motor and current limiting is de-activated, and care should be taken when using the  $\overline{BRAKE}$  pin.  $\overline{BRAKE}$  has an internal 4k $\Omega$  pull-up as shown in Figure 10, and can be driven by a switch to ground, an open collector or drain logic signal, or a TTL logic signal.

### UNDERVOLTAGE LOCKOUT

Undervoltage lockout is used to protect the 3-phase bridge power stage from a low  $V_{DD}$  condition. Undervoltage is triggered at  $V_{DD}$  of 9.5V or less and is indicated by a TTL low output on the UV FAULT pin. Undervoltage lockout also turns off all output drivers (LA, LB, LC,  $\overline{HA}$ ,  $\overline{HB}$ , and  $\overline{HC}$ ). The comparator that triggers undervoltage lockout has 150mV of hysteresis.

## DESIGN CONSIDERATIONS

### INTERFACING TO A 3-PHASE BRIDGE POWER STAGE

The ML4426 output drivers are configured to drive a 3 phase bridge power stage. For applications with buss voltages from 12V up to 80V, level shifting circuitry can be used to drive higher voltage P-channel MOSFETS for the high side switches as shown in Figure 11.

The most flexible configuration is to use high side drivers to control N-Channel MOSFETS (or IGBTs) which allows applications from less than 12V up to 600V. Figure 12 shows the interface between the ML4426 and IR2118 high side drivers from International Rectifier. This configuration is capable of driving motors from busses of up to 320V. The  $\overline{BRAKE}$  pin can be pulsed prior to startup with an RC circuit. This charges the bootstrap capacitors (C19, C20, and C21) for the three high side drivers, allowing the reset phase to operate normally. These capacitors must be sized so that they stay sufficiently charged during the align mode. Refer to AN-43 for additional applications information on the ML4426.

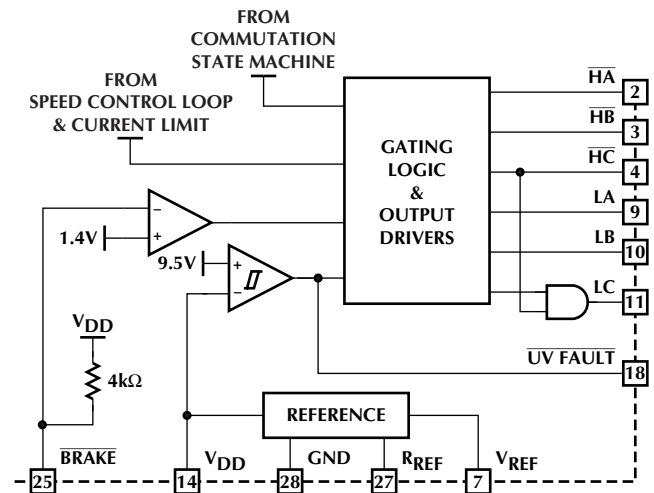

Figure 10. Cross Conduction, Brake, and UVLO Circuits

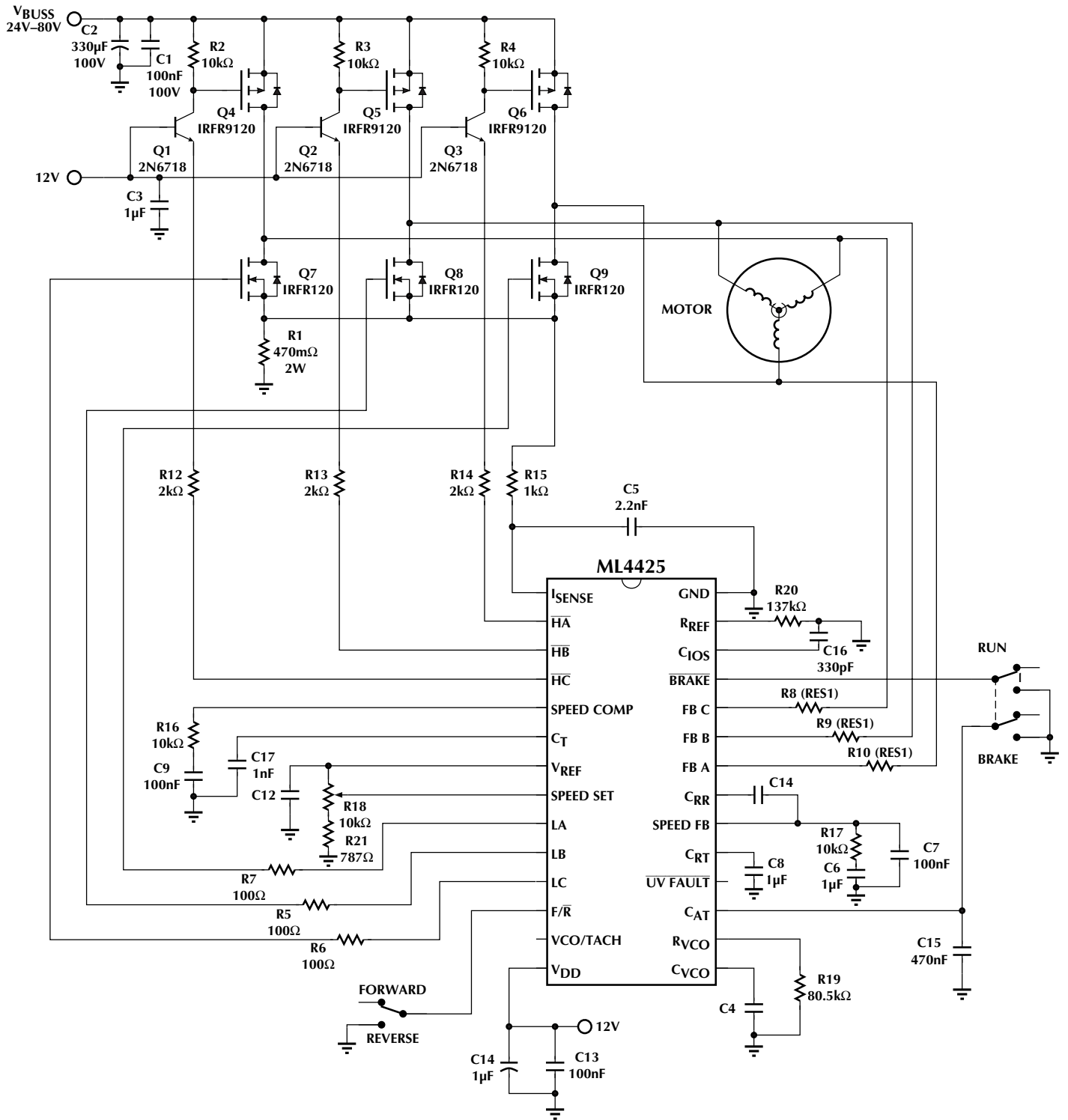

Figure 11. Driving Lower Voltage Motors (12 to 80V)

# ML4426

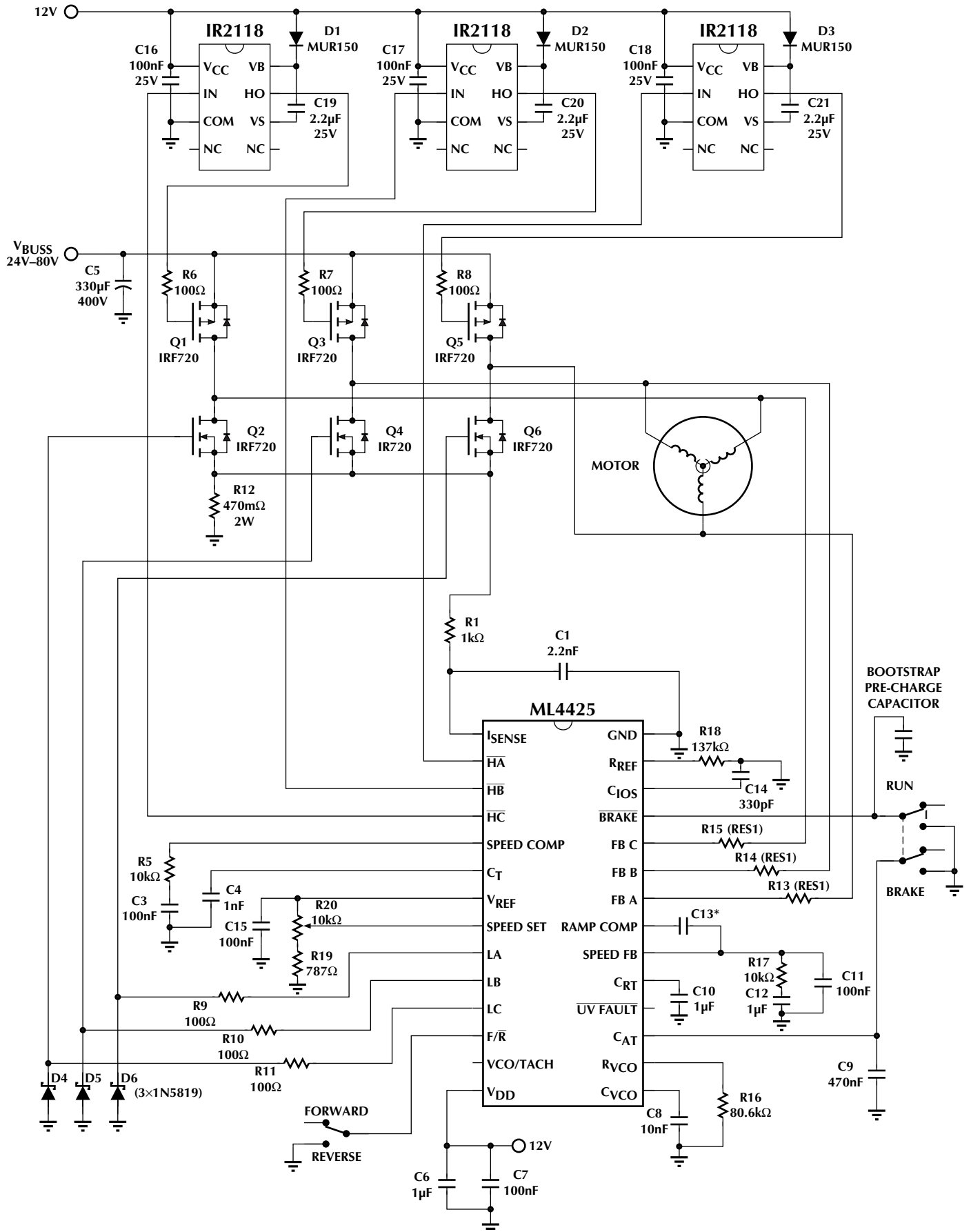
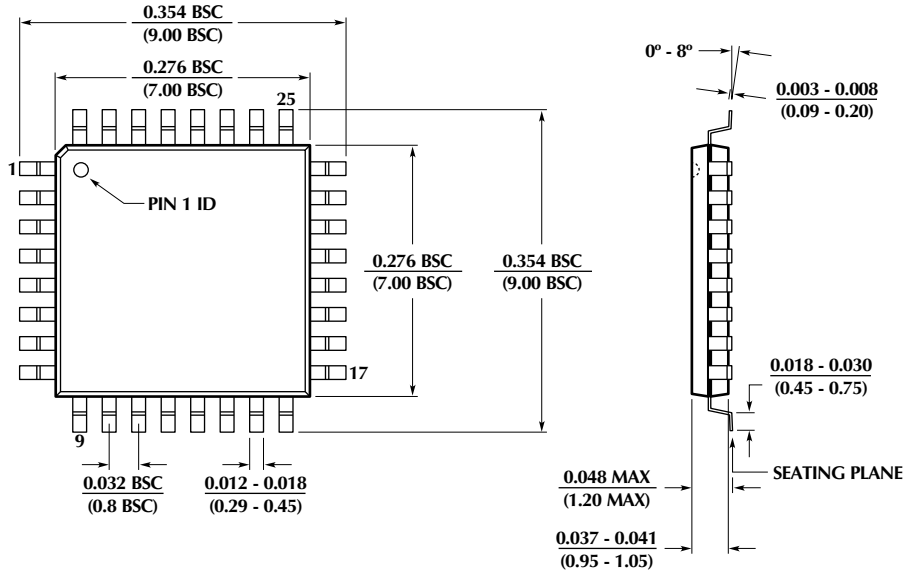

Figure 12. ML4426 High Voltage Motor Drive Application Circuit

**PHYSICAL DIMENSIONS** inches (millimeters)

**Package: H32-7**  
**32-Pin (7 x 7 x 1mm) TQFP**



**Package: P28N**  
**28-Pin Narrow PDIP**

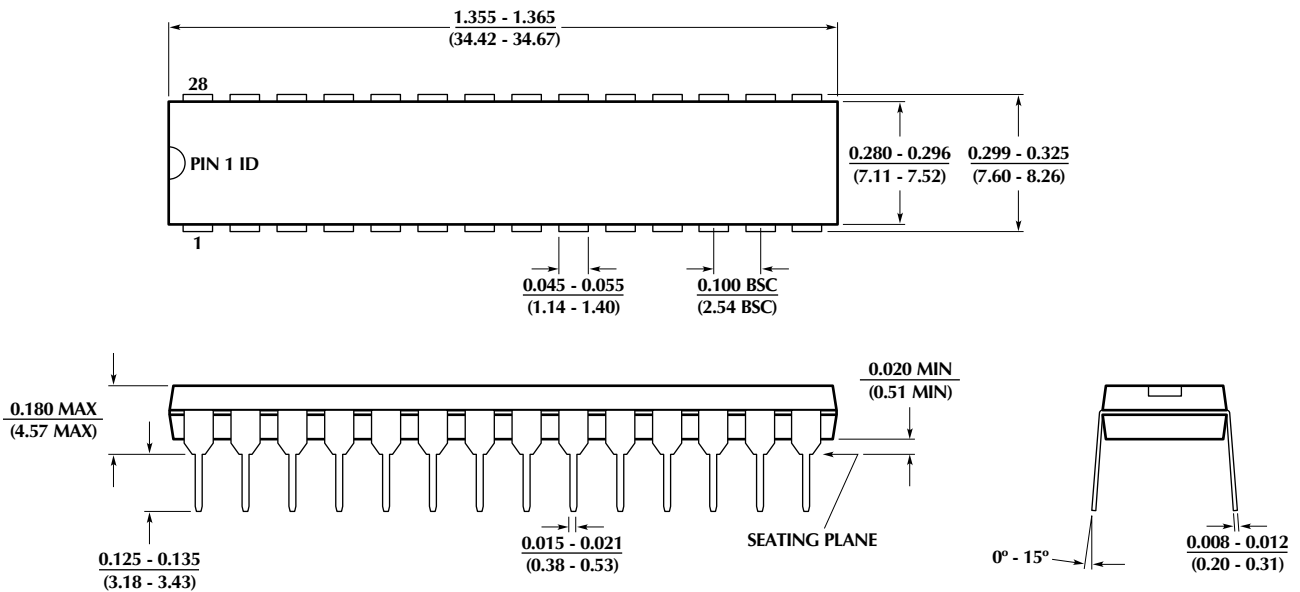

# ML4426

## PHYSICAL DIMENSIONS inches (millimeters)

Package: S28  
28-Pin SOIC

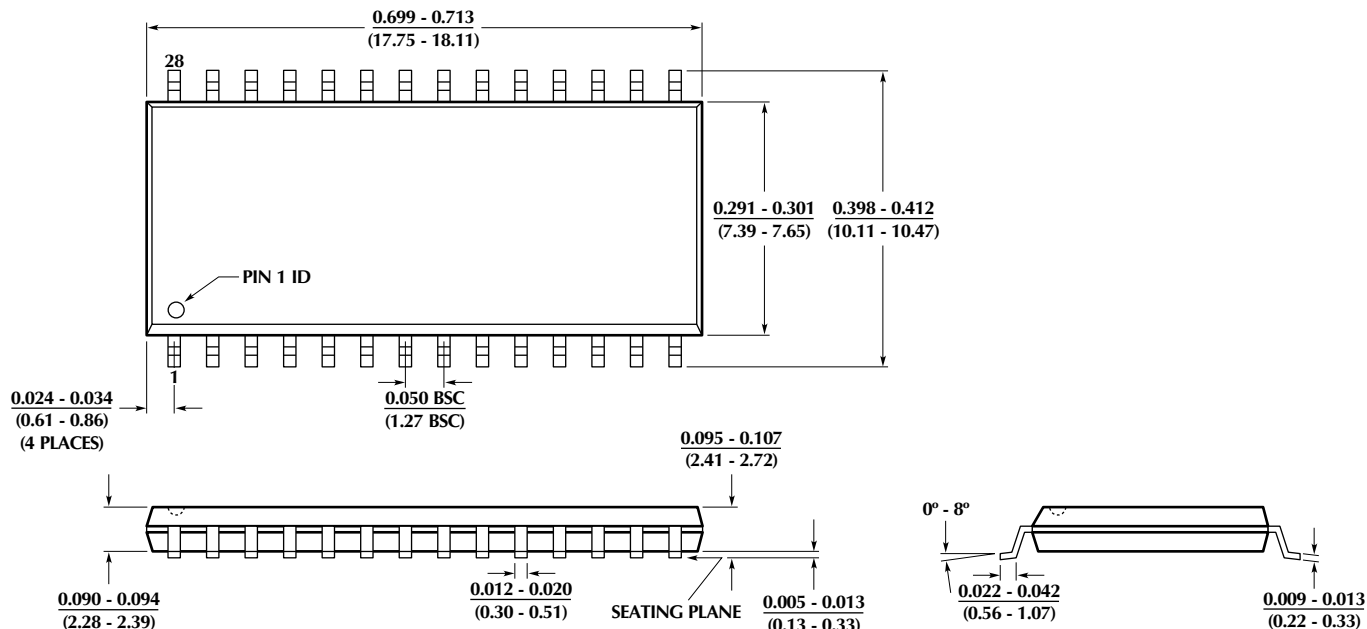

## ORDERING INFORMATION

| PART NUMBER            | TEMPERATURE RANGE | PACKAGE             |
|------------------------|-------------------|---------------------|
| ML4426CP (End of Life) | 0°C to 70°C       | 28-Pin PDIP (P28N)  |
| ML4426CS (End of Life) | 0°C to 70°C       | 28-Pin SOIC (S28)   |
| ML4426CH (End of Life) | 0°C to 70°C       | 32-Pin TQFP (H32-7) |
| ML4426IP (End of Life) | -40°C to 85°C     | 28-Pin PDIP (P28N)  |
| ML4426IS (End of Life) | -40°C to 85°C     | 28-Pin SOIC (S28)   |
| ML4426IH (End of Life) | -40°C to 85°C     | 32-Pin TQFP (H32-7) |

© Micro Linear 1998. **Micro Linear** is a registered trademark of Micro Linear Corporation. All other trademarks are the property of their respective owners.

Products described herein may be covered by one or more of the following U.S. patents: 4,897,611; 4,964,026; 5,027,116; 5,281,862; 5,283,483; 5,418,502; 5,508,570; 5,510,727; 5,523,940; 5,546,017; 5,559,470; 5,565,761; 5,592,128; 5,594,376; 5,652,479; 5,661,427; 5,663,874; 5,672,959; 5,689,167; 5,714,897; 5,717,798; 5,742,151; 5,747,977; 5,754,012; 5,757,174; 5,767,653; Japan: 2,598,946; 2,619,299; 2,704,176. Other patents are pending.

Micro Linear reserves the right to make changes to any product herein to improve reliability, function or design. Micro Linear does not assume any liability arising out of the application or use of any product described herein, neither does it convey any license under its patent right nor the rights of others. The circuits contained in this data sheet are offered as possible applications only. Micro Linear makes no warranties or representations as to whether the illustrated circuits infringe any intellectual property rights of others, and will accept no responsibility or liability for use of any application herein. The customer is urged to consult with appropriate legal counsel before deciding on a particular application.

DS4426-01

2092 Concourse Drive  
San Jose, CA 95131  
Tel: 408/433-5200  
Fax: 408/432-0295  
www.microlinear.com