



MLX90247 family

Discrete Infrared Thermopile Detectors

Features and Benefits

- Solid state sensor
- High reliability
- Low cost, small size
- On chip temperature sensor

Applications

- Gas analysis equipment
- IR thermometers
- Automotive contactless temperature sensing.



Ordering Information

Part No	Ta	Suffix	Package code	Type	Description
MLX90247	E (-20C to +85C)		SF(TO-39)	DSA	Thermopile detector with on-chip PTC thermistor, floating thermopile outputs.
MLX90247	E (-20C to +85C)		SF(TO-39)	DSE	Thermopile detector with high sensitivity NTC thermistor, floating thermopile outputs.
MLX90247	E (-20C to +85C)		SF(TO-39)	DSG	Thermopile detector with on-chip PTC thermistor, symmetrical thermopile outputs

1. Functional Diagrams

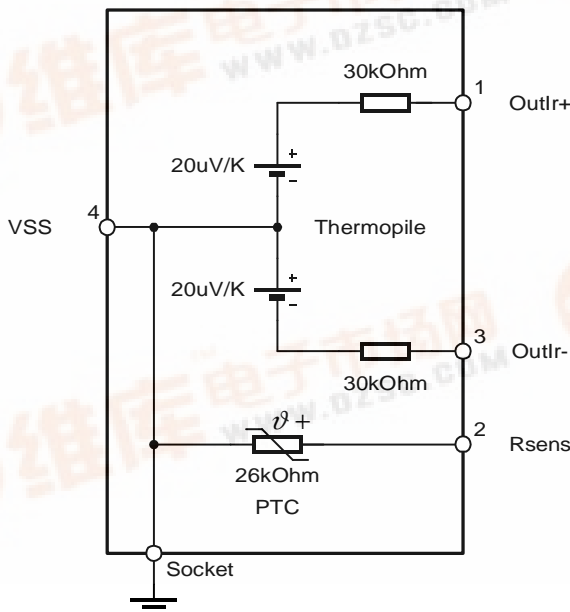

MLX90247DSG

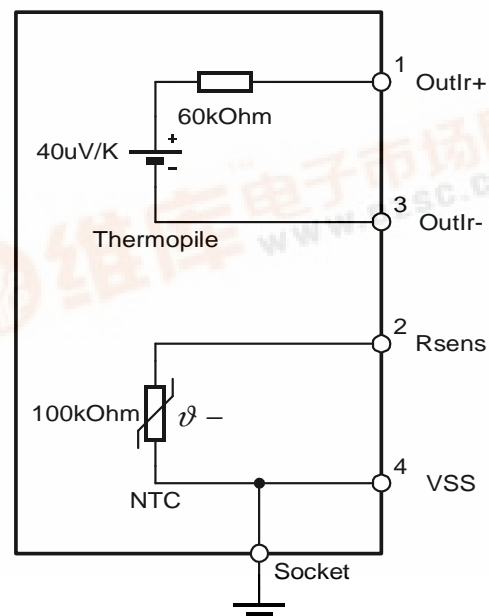

MLX90247DSE

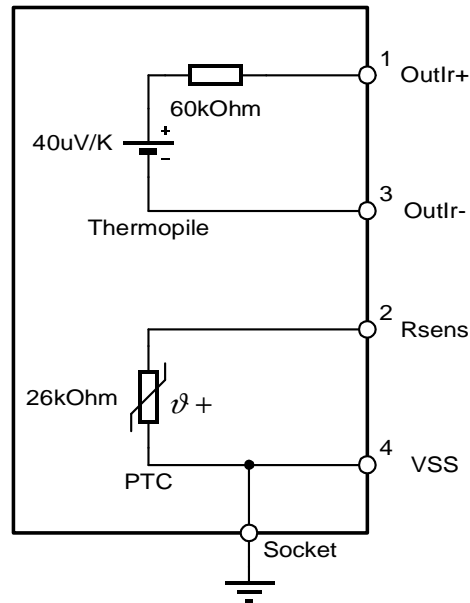

MLX90247DSA

2. Description

The MLX90247family sensors are thermopile sensors IC which detects very small amounts of heat radiation. The sensors consist of a membrane with a thermopile on top of it. The hot junctions of the thermopile are positioned near the center of the membrane and the cold junctions above the bulk silicon edge. Due to the low thermal conductivity of the membrane, absorbed heat will cause the temperature to increase more at the center of the membrane than at the edge above the bulk. This temperature difference is converted to an electric potential by the thermo-electric effect in the thermopile junctions. No supply voltage is needed.

The MLX90247DSG sensor IC is integrated together with a PTC thermistor. The thermopile sensor is grounded at the middle point, so that the output common-mode voltage is at ground potential. Using grounded thermopile sensor gives improved EMC susceptibility in some applications.

The MLX90247DSE sensor IC is packaged together with a 100k NTC chip thermistor. The

sensor and thermistor can be used independent of each other if desired, as the thermopile potential is floating. This type of thermistor has better sensitivity than the PTC types, but must be used in smaller ambient ranges. Typical applications are ear thermometers or other medical equipment.

The MLX90247DSA sensor IC is integrated together with a PTC thermistor. The sensor and thermistor can be used independent of each other if desired, as the thermopile potential is floating.

TABLE OF CONTENTS

FEATURES AND BENEFITS	1
APPLICATIONS	1
1. FUNCTIONAL DIAGRAMS	1-1
2. DESCRIPTION	2-2
3. GLOSSARY OF TERMS	4
4. ABSOLUTE MAXIMUM RATINGS	4
5. MLX90247DSG	5
5.1. MLX90247DSG ELECTRICAL SPECIFICATIONS	5
6. MLX90247DSE	6
6.1. MLX90247DSE ELECTRICAL SPECIFICATIONS	6
7. MLX90247DSA	7
7.1. MLX90247DSA ELECTRICAL SPECIFICATIONS	7
8. PIN OUT	8
9. HOUSING SPECIFICATIONS	8
10. PACKAGE OUT	9
11. RELIABILITY INFORMATION	10
12. ESD PRECAUTIONS	10
13. DISCLAIMER	11

3. Glossary of Terms

IR : Infrared. Every object emits infrared radiation in relation to its temperature. This effect can be used to measure the temperature without the need for physical contact.

NTC : See Thermistor

PTC : See Thermistor

Thermistor : Temperature dependant resistor. Basically there are 2 types. The types that increase their resistance with rising temperature are PTC (positive thermal coefficient) types. The ones that decrease their resistance with rising temperature we call NTC (negative thermal coefficient) types.

4. Absolute Maximum Ratings

Operating Temperature Range	-20 ~ 85 °C	
Operating Temperature Range	-40 ~ 150 °C	
Soldering Temperature	< 220 °C	T < 5 sec.

Exceeding the absolute maximum ratings may cause permanent damage. Exposure to absolute-maximum-rated conditions for extended periods may affect device reliability.

5. MLX90247DSG

5.1. MLX90247DSG Electrical Specifications

DC Operating Parameters $T_A = -20^{\circ}\text{C}$ to 85°C , (unless otherwise specified)

Parameter	Symbol	Test Conditions	Min	Typ	Max	Units
Thermopile Resistance	Rtp	@298K	44		75	k Ω
Sensitivity	S	sensor @298K black body @299K	29		55	$\mu\text{V}/\text{K}$
TC of Sensitivity	TCs	@298K		0.1		%/K
Thermistor Value	Rptc	@298K	18.2	26	33.8	k Ω
Thermal Coefficient PTC ⁽¹⁾	A1	25 $^{\circ}\text{C}$ -100 $^{\circ}\text{C}$	5720	7150	8580	ppm/K
	A2		11.57			ppm/K ²

$$R(T) = R(298K) \cdot [1 + A1 \cdot (T - 298K) + A2 \cdot (T - 298K)^2]$$

Note:

when measuring resistances with an ohm meter, please take care that the internal protection diodes, as indicated in the diagram below, are always reverse biased.

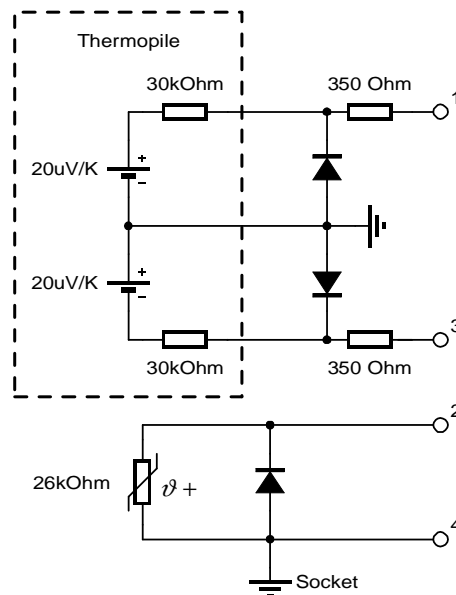

6. MLX90247DSE

6.1. MLX90247DSE Electrical Specifications

DC Operating Parameters $T_A = -20^{\circ}\text{C}$ to 85°C , (unless otherwise specified)

Parameter	Symbol	Test Conditions	Min	Typ	Max	Units
Thermopile Resistance	Rtp	@298K	44		75	k Ω
Sensitivity	S	sensor @298K black body @299K	29		55	$\mu\text{V}/\text{K}$
TC of Sensitivity	TCs	@298K		0.1		%/K
Thermistor Value	Rntc	@298K	95	100	105	k Ω
Thermal Coefficient NTC	β_{ntc}	0-50 $^{\circ}\text{C}$ ⁽¹⁾	4120	4140	4161	K

Tolerance given between 15 $^{\circ}\text{C}$ and 35 $^{\circ}\text{C}$. Typical value corresponds to a relative resistance change of - 4.68%/ $^{\circ}\text{C}$. Definition of β is $\Delta \ln R / \Delta (1/T)$ with T in K. (Naperian logarithm).

Note:

when measuring resistances with an ohm meter, please take care that the internal protection diodes, as indicated in the functional diagram below, are always reverse biased.

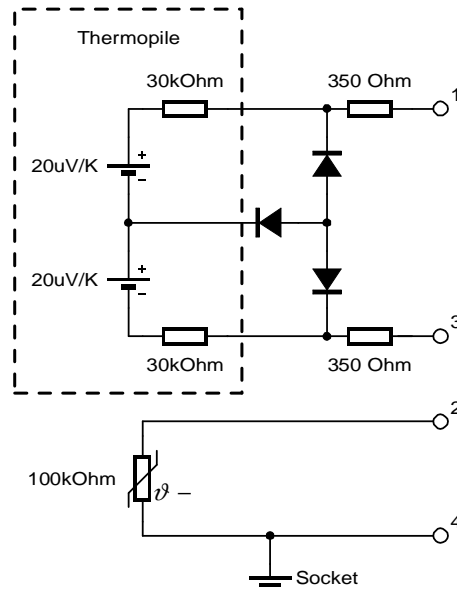

7. MLX90247DSA

7.1. MLX90247DSA Electrical Specifications

DC Operating Parameters $T_A = -20^{\circ}\text{C}$ to 85°C , (unless otherwise specified)

Parameter	Symbol	Test Conditions	Min	Typ	Max	Units
Thermopile Resistance	Rtp	@298K	44		75	k Ω
Sensitivity	S	sensor @298K black body @299K	29		55	$\mu\text{V}/\text{K}$
TC of Sensitivity	TCs	@298K		0.1		%/K
Thermistor Value	Rptc	@298K	18.2	26	33.8	k Ω
Thermal Coefficient PTC ⁽¹⁾	A1 A2	25 $^{\circ}\text{C}$ -100 $^{\circ}\text{C}$	5720	7150 11.57	8580	ppm/K ppm/K ²

$$R(T) = R(298K) \cdot [1 + A1 \cdot (T - 298K) + A2 \cdot (T - 298K)^2]$$

Note:

when measuring resistances with an ohm meter, please take care that the internal protection diodes, as indicated in the functional diagram below, are always reverse biased.

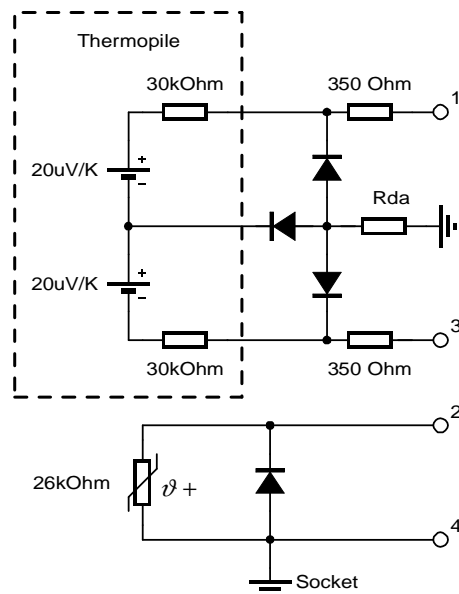

8. Pin Out

TO-39 package - connections

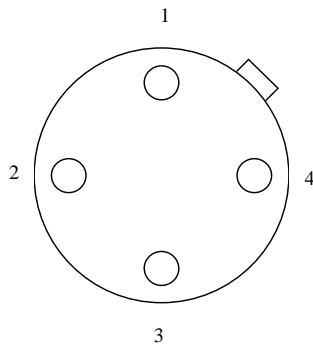

Top view = pins down

Pin	Symbol	Description
1	Outlr+	Infrared Thermopile positive output
2	Rsens	Thermistor for sensor ambient temperature measurement
3	Outlr-	Infrared Thermopile negative output
4	Vss	Thermistor and thermopile ground / case potential

9. Housing specifications

Parameter	Value	Unit	Comment
TO-39 specifications			
Metal cap			Welded
Filling gas			Nitrogen
Filter specifications			
Transmission	>75	%	$7.5\mu < \lambda < 13.5\mu$
Transmission	<0.5	%	$0 < \lambda < 5\mu$
Sensor window			
FOV	100	°	Full opening angle: Determined by aperture
Aperture diameter	3.5	mm	Default

10. Package Out

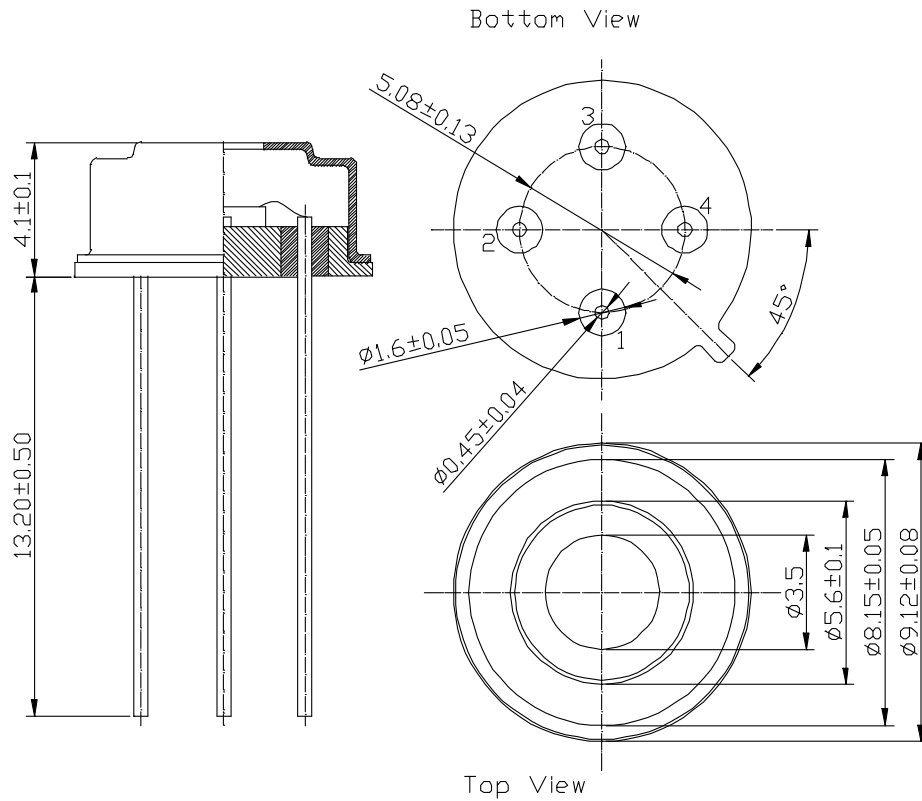

11. Reliability Information

Melexis devices are classified and qualified regarding suitability for infrared, vapor phase and wave soldering with usual (63/37 SnPb-) solder (melting point at 183degC).

The following test methods are applied:

- IPC/JEDEC J-STD-020A (issue April 1999)
Moisture/Reflow Sensitivity Classification For Nonhermetic Solid State Surface Mount Devices
- CECC00802 (issue 1994)
Standard Method For The Specification of Surface Mounting Components (SMDs) of Assessed Quality
- MIL 883 Method 2003 / JEDEC-STD-22 Test Method B102 Solderability

For all soldering technologies deviating from above mentioned standard conditions (regarding peak temperature, temperature gradient, temperature profile etc) additional classification and qualification tests have to be agreed upon with Melexis.

The application of Wave Soldering for SMD's is allowed only after consulting Melexis regarding assurance of adhesive strength between device and board.

For more information on manufacturability/solderability see quality page at our website:

<http://www.melexis.com/>

12. ESD Precautions

Electronic semiconductor products are sensitive to Electro Static Discharge (ESD).

Always observe Electro Static Discharge control procedures whenever handling semiconductor products.

13. Disclaimer

Devices sold by Melexis are covered by the warranty and patent indemnification provisions appearing in its Term of Sale. Melexis makes no warranty, express, statutory, implied, or by description regarding the information set forth herein or regarding the freedom of the described devices from patent infringement. Melexis reserves the right to change specifications and prices at any time and without notice. Therefore, prior to designing this product into a system, it is necessary to check with Melexis for current information. This product is intended for use in normal commercial applications. Applications requiring extended temperature range, unusual environmental requirements, or high reliability applications, such as military, medical life-support or life-sustaining equipment are specifically not recommended without additional processing by Melexis for each application.

The information furnished by Melexis is believed to be correct and accurate. However, Melexis shall not be liable to recipient or any third party for any damages, including but not limited to personal injury, property damage, loss of profits, loss of use, interrupt of business or indirect, special incidental or consequential damages, of any kind, in connection with or arising out of the furnishing, performance or use of the technical data herein. No obligation or liability to recipient or any third party shall arise or flow out of Melexis' rendering of technical or other services.

© 2002 Melexis NV. All rights reserved.

For the latest version of this document, go to our website at:

www.melexis.com

Or for additional information contact Melexis Direct:

Europe and Japan:	All other locations:
Phone: +32 13 67 04 95	Phone: +1 603 223 2362
E-mail: sales_europe@melexis.com	E-mail: sales_usa@melexis.com