

MP7543

5 V CMOS

Serial Input 12-Bit

Digital-to-Analog Converter



FEATURES

- 12-Bit DAC with Serial Digital Input Interface
- Nonlinearity $\pm 1/2$ LSB from T_{min} to T_{max}
- Lowest Sensitivity to Amplifier V_{OS}
- Low Output Capacitance
- Full 4-Quadrant Multiplication
- Latch-Up Free
- Asynchronous CLEAR Input
- Serial Load On Positive or Negative Strobes
- +5 V Supply Operation
- 3 V Version: MP75L43
- 4-Bit Parallel Version: MP7542

BENEFITS

- Compatible with Serial Addressing Systems

GENERAL DESCRIPTION

The MP7543 is a precision, 12-bit CMOS 4-quadrant multiplying Digital-to-Analog Converter designed for serial interface applications.

The MP7543 consists of two 12-bit registers, control logic and a 12-bit multiplying D/A converter. The input register (register A) is a 12-bit serial-in parallel-out shift register. Serial data at the SR1 pin is clocked into Register A on the leading or trailing edge (user selected) of the strobe input, with the MSB loaded first. Register B is a 12-bit parallel-in parallel-out register that follows register A. The contents of register A are loaded into register B

under control of the Load inputs.

A CLEAR input is provided for the asynchronous resetting of register B to all 0's.

The MP7543 is manufactured using an advanced thin film monolithic CMOS fabrication process. A unique decoding technique is utilized yielding excellent accuracy and stability. 12-bit linearity is achieved without laser trimming.

The MP7543 reduces the additional linearity errors due to output amplifier offset to only 330 μ V per millivolt of offset - half the value of a standard R-2R CMOS DAC design approach.

SIMPLIFIED BLOCK DIAGRAM

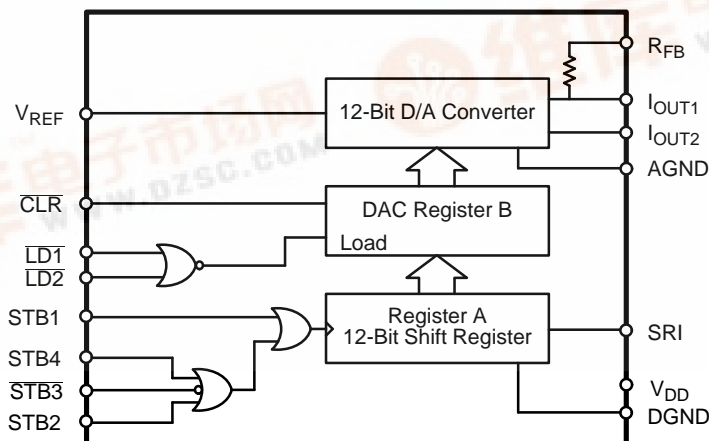

ORDERING INFORMATION

Package Type	Temperature Range	Part No.	INL (LSB)	DNL (LSB)	Gain Error (LSB)
Plastic Dip	-40 to +85°C	MP7543JN	±1	±2	±14.5
Plastic Dip	-40 to +85°C	MP7543KN	±1/2	±1	±14.5
SOIC	-40 to +85°C	MP7543JS	±1	±2	±14.5
SOIC	-40 to +85°C	MP7543KS	±1/2	±1	±14.5
PLCC	-40 to +85°C	MP7543JP	±1	±2	±14.5
PLCC	-40 to +85°C	MP7543KP	±1/2	±1	±14.5
Ceramic Dip	-40 to +85°C	MP7543AD	±1	±2	±14.5
Ceramic Dip	-40 to +85°C	MP7543BD	±1/2	±1	±14.5
Ceramic Dip	-55 to +125°C	MP7543SD*	±1	±2	±14.5
Ceramic Dip	-55 to +125°C	MP7543TD*	±1/2	±1	±14.5

*Contact factory for non-compliant military processing

PIN CONFIGURATIONS

See Packaging Section for Package Dimensions

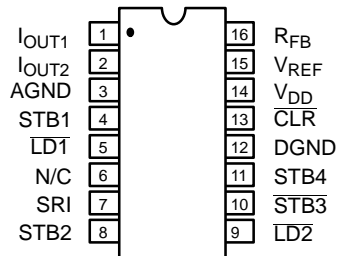

16 Pin CDIP, PDIP (0.300")
D16, N16

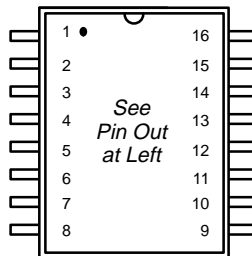

16 Pin SOIC (Jedec, 0.300")
S16

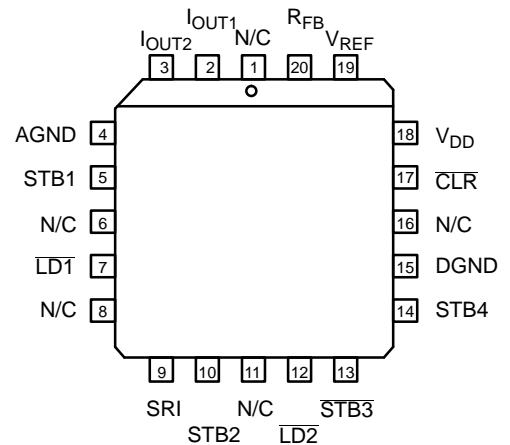

20 Pin PLCC
P20

PIN OUT DEFINITIONS

PDIP, CDIP and SOIC

PIN NO.	NAME	DESCRIPTION
1	I _{OUT1}	DAC current output pin. Normally terminated at op amp virtual ground.
2	I _{OUT2}	DAC current output pin. Normally terminated at AGND.
3	AGND	Analog Ground.
4	STB1	Register A Strobe 1 input, <i>See Table 1.</i>
5	$\overline{LD1}$	DAC Register B Load 1 input. When $\overline{LD1}$ and $\overline{LD2}$ go low the contents of Register A are loaded into DAC Register B.
6	N/C	No Connection.
7	SRI	Serial Data Input to Register A.
8	STB2	Register A Strobe 2 input, <i>See Table 1.</i>
9	$\overline{LD2}$	DAC Register B Load 2 input. When $\overline{LD1}$ and $\overline{LD2}$ go low the contents of Register A are loaded into DAC Register B.
10	$\overline{STB3}$	Register A Strobe 3 input, <i>See Table 1.</i>
11	STB4	Register A Strobe 4 input, <i>See Table 1.</i>
12	DGND	Digital Ground.
13	\overline{CLR}	Register B CLEAR input (active LOW), can be used to asynchronously reset Register B to 0000 0000 0000.
14	V _{DD}	+5 V Supply Input.
15	V _{REF}	Reference input. Can be positive or negative DC voltage or AC signal.
16	R _{FB}	DAC Feedback Resistor.

PLCC

PIN NO.	NAME	DESCRIPTION
1	N/C	No Connection.
2	I _{OUT1}	DAC current output pin. Normally terminated at op amp virtual ground.
3	I _{OUT2}	DAC current output pin. Normally terminated at AGND.
4	AGND	Analog Ground.
5	STB1	Register A Strobe 1 input, <i>See Table 1.</i>
6	N/C	No Connection.
7	$\overline{LD1}$	DAC Register B Load 1 input. When $\overline{LD1}$ and $\overline{LD2}$ go low the contents of Register A are loaded into DAC Register B.
8	N/C	No Connection.
9	SR1	Serial Data Input to Register A.
10	STB2	Register A Strobe 2 input, <i>See Table 1.</i>
11	N/C	No Connection.
12	$\overline{LD2}$	DAC Register B Load 2 input. When $\overline{LD1}$ and $\overline{LD2}$ go low the contents of Register A are loaded into DAC Register B.
13	$\overline{STB3}$	Register A Strobe 3 input, <i>See Table 1.</i>
14	STB4	Register A Strobe 4 input, <i>See Table 1.</i>
15	DGND	Digital Ground.
16	N/C	No Connection.
17	\overline{CLR}	Register B CLEAR input (active LOW), can be used to asynchronously reset Register B to 0000 0000 0000.
18	V _{DD}	+5 V Supply Input.
19	V _{REF}	Reference input. Can be positive or negative DC voltage or AC signal.
20	R _{FB}	DAC Feedback Resistor.

ELECTRICAL CHARACTERISTICS

($V_{DD} = +5\text{ V}$, $V_{REF} = +10\text{ V}$ unless otherwise noted)

Parameter	Symbol	25°C			Tmin to Tmax		Units	Test Conditions/Comments
		Min	Typ	Max	Min	Max		
STATIC PERFORMANCE¹								
Resolution (All Grades)	N	12			12		Bits	
Integral Non-Linearity (Relative Accuracy) J, A, S K, B, T	INL			±1 ±1/2		±1 ±1/2	LSB	Best Fit Straight Line Spec. (Max INL – Min INL) / 2
Differential Non-Linearity J, A, S K, B, T	DNL			±2 ±1		±2 ±1	LSB	Monotonicity: 11 Bits Guaranteed 12 Bits Guaranteed
Gain Error J, A, K, B, S, T	GE			±12.3		±14.5	LSB	Using Internal R_{FB}
Gain Temperature Coefficient ²	TC_{GE}					±2	ppm/°C	$\Delta\text{Gain}/\Delta\text{Temperature}$
Power Supply Rejection Ratio	PSRR			±50		±100	ppm/%	$ \Delta\text{Gain}/\Delta V_{DD} \Delta V_{DD} = \pm 5\%$
Output Leakage Current J, K, A, B S, T	I_{OUT}			±10 ±10		±10 ±200	nA	
DYNAMIC PERFORMANCE								
Current Output Settling Time ²	t_S			2		2	μs	$R_L=100\Omega$, $C_L=13\text{pF}$ Full Scale Output Settles to 1/2 LSB of Final Value
AC Feedthrough at I_{OUT1} ²	F_T			2.5		2.5	mV p-p	$V_{REF} = 10\text{kHz}$, 20 Vp-p, sinewave
REFERENCE INPUT								
Input Resistance	R_{IN}	5	10	20	5	20	kΩ	
DIGITAL INPUTS³								
Logical "1" Voltage	V_{IH}	3.0			3.0		V	
Logical "0" Voltage	V_{IL}			0.8		0.8	V	
Input Leakage Current	I_{LKG}			±1		±1	μA	
ANALOG OUTPUTS²								
Output Capacitance	C_{OUT1} C_{OUT1} C_{OUT2} C_{OUT2}			260 100 50 210		260 100 50 210	pF pF pF pF	DAC Inputs all 1's DAC Inputs all 0's DAC Inputs all 1's DAC Inputs all 0's
POWER SUPPLY								
Supply Voltage	V_{DD}	4.75		5.25	4.75	5.25	V	$V_{DD} = +5\text{ V} \pm 5\%$ for specified performance
Supply Current	I_{DD}			2.5		2.5	mA	All digital inputs = 0 V or all = 5 V

ELECTRICAL CHARACTERISTICS (CONT'D)

Parameter	Symbol	25°C			Tmin to Tmax		Units	Test Conditions/Comments
		Min	Typ	Max	Min	Max		
SWITCHING CHARACTERISTICS^{2, 4}								
Serial Input to Strobe Set-up Time	t _{DS1}	50			100		ns	STB1 used as a strobe
Serial Input to Strobe Set-up Time	t _{DS4}	0			0		ns	STB4 used as a strobe
Serial Input to Strobe Set-up Time	t _{DS3}	0			0		ns	STB3 used as a strobe
Serial Input to Strobe Set-up Time	t _{DS2}	20			40		ns	STB2 used as a strobe
Serial Input to Strobe Hold Time	t _{DH1}	30			60		ns	STB1 used as a strobe
Serial Input to Strobe Hold Time	t _{DH4}	80			160		ns	STB4 used as a strobe
Serial Input to Strobe Hold Time	t _{DH3}	80			160		ns	STB3 used as a strobe
Serial Input to Strobe Hold Time	t _{DH2}	60			120		ns	STB2 used as a strobe
SRI Data Pulse Width	t _{SRI}	80			160		ns	
STB1 Pulse Width	t _{STB1}	80			160		ns	
STB4 Pulse Width	t _{STB4}	100			200		ns	
STB3 Pulse Width	t _{STB3}	100			200		ns	
STB2 Pulse Width	t _{STB2}	80			160		ns	
Load Pulse Width	t _{LD1, 2}	150			300		ns	
Minimum time between strobing Reg. A and loading Reg. B	t _{ASB}	0			0		ns	
CLR pulse width	t _{CLR}	200			400		ns	

NOTES:

- 1 Full Scale Range (FSR) is 10V for unipolar mode.
- 2 Guaranteed but not production tested.
- 3 Digital input levels should not go below ground or exceed the positive supply voltage, otherwise damage may occur.
- 4 See timing diagram.

Specifications are subject to change without notice

ABSOLUTE MAXIMUM RATINGS (TA = +25°C unless otherwise noted)^{1, 2, 3}

V_{DD} to GND +7 V
 Digital Input Voltage to GND (2) . GND -0.5 to V_{DD} +0.5 V
 I_{OUT1}, I_{OUT2} to GND GND -0.5 to V_{DD} +0.5 V
 V_{REF} to GND (2) ±25 V
 V_{RFB} to GND (2) ±25 V
 AGND to DGND ±1 V
 (Functionality Guaranteed ±0.5 V)

Storage Temperature -65°C to +150°C
 Lead Temperature (Soldering, 10 seconds) +300°C
 Package Power Dissipation Rating to 75°C
 CDIP, PDIP, SOIC, PLCC 700mW
 Derates above 75°C 10mW/°C

NOTES:

- 1 Stresses above those listed under "Absolute Maximum Ratings" may cause permanent damage to the device. This is a stress rating only and functional operation at or above this specification is not implied. Exposure to maximum rating conditions for extended periods may affect device reliability.
- 2 Any input pin which can see a value outside the absolute maximum ratings should be protected by Schottky diode clamps (HP5082-2835) from input pin to the supplies. *All inputs have protection diodes* which will protect the device from short transients outside the supplies of less than 100mA for less than 100µs.
- 3 GND refers to AGND and DGND.

TIMING DIAGRAM

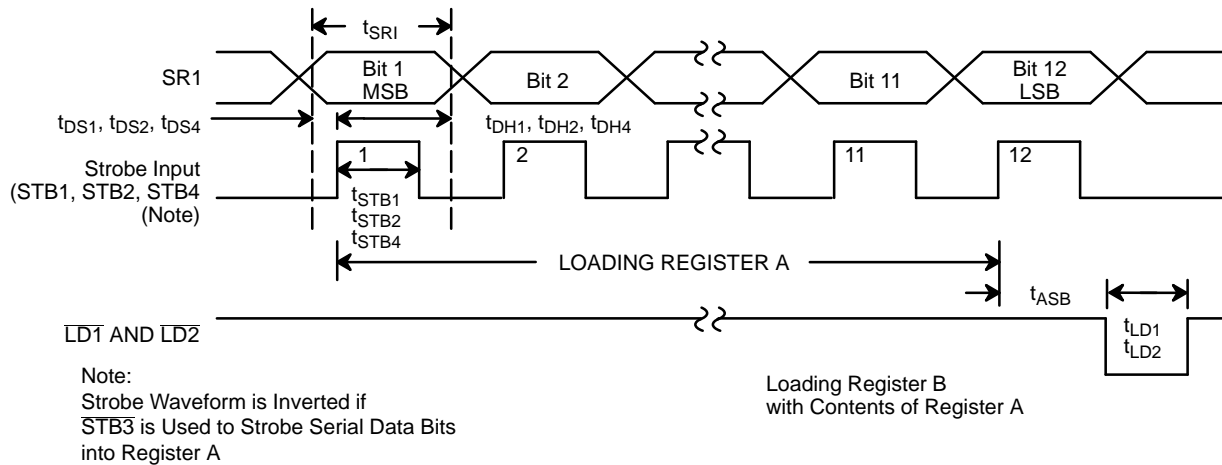

MP7543 Logic Inputs							MP7543 Operation	Notes
Register A Control Inputs			Register B Control Inputs					
STB4	STB3	STB2	STB1	CLR	LD2			
0	1	0	↗	X	X	X	Data appearing at SRI strobed into Register A	2, 3
0	1	↗	0	X	X	X	Data appearing at SRI strobed into Register A	2, 3
0	↘	0	0	X	X	X	Data appearing at SRI strobed into Register A	2, 3
↗	1	0	0	X	X	X	Data appearing at SRI strobed into Register A	2, 3
1	X	X	X				No Operation (Register A)	3
X	0	X	X					
X	X	1	X					
X	X	X	1					
				0	X	X	Clear Register B to code 0000 0000 0000 (Asynchronous)	1, 3
				1	1	X	No Operation (Register B)	3
				1	X	1		
				1	0	0	Load Register B with the contents of Register A	3

NOTES

1. CLR = 0 Asynchronously resets Register B to 0000 0000 0000, but has no effect on Register A.
2. Serial data is loaded into Register A MSB first, on edges shown ↗ is positive edge, ↘ is negative edge.
3. 0 = Logic LOW, 1 = Logic HIGH, X = Don't Care.

Table 1. Truth Table

APPLICATION NOTES

Refer to Section 8 for Applications Information

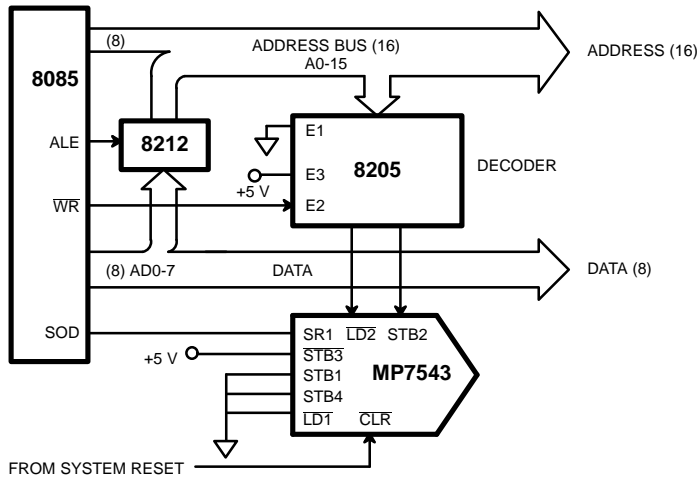

Figure 1. MP7543 8085 Interface

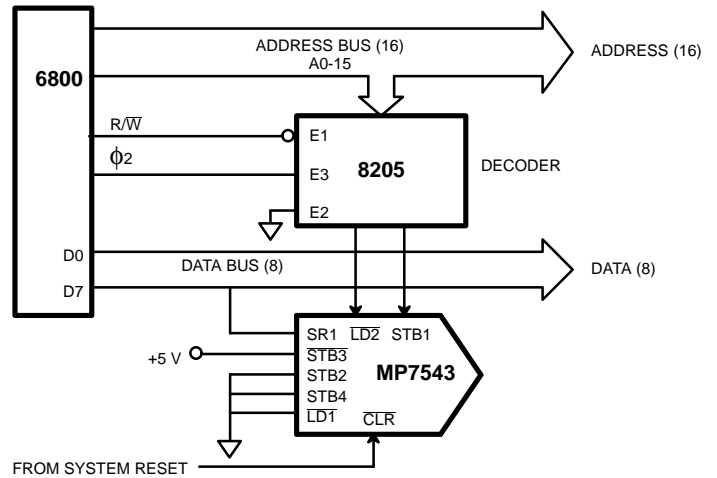

Figure 2. MP7543 MC6800 Interface

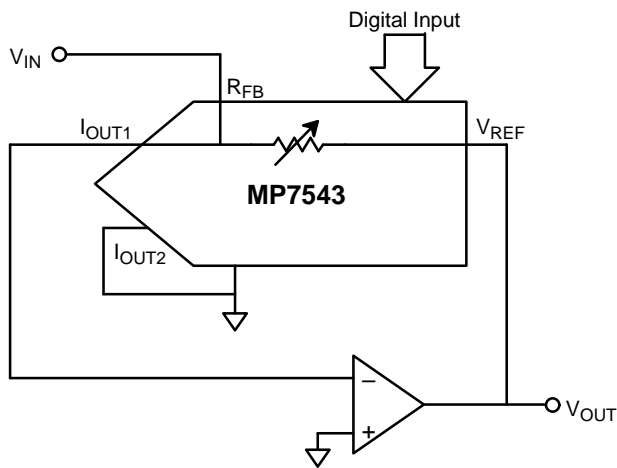
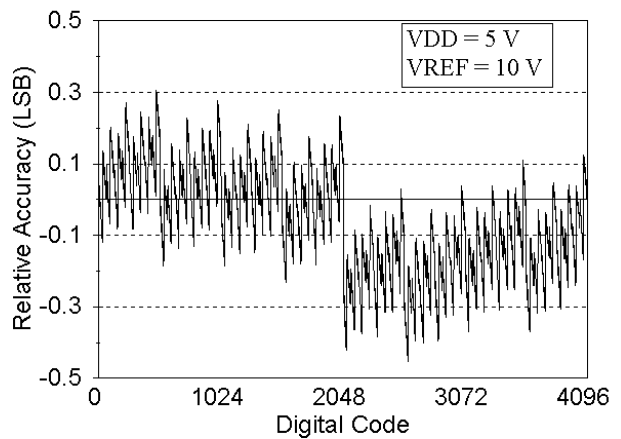
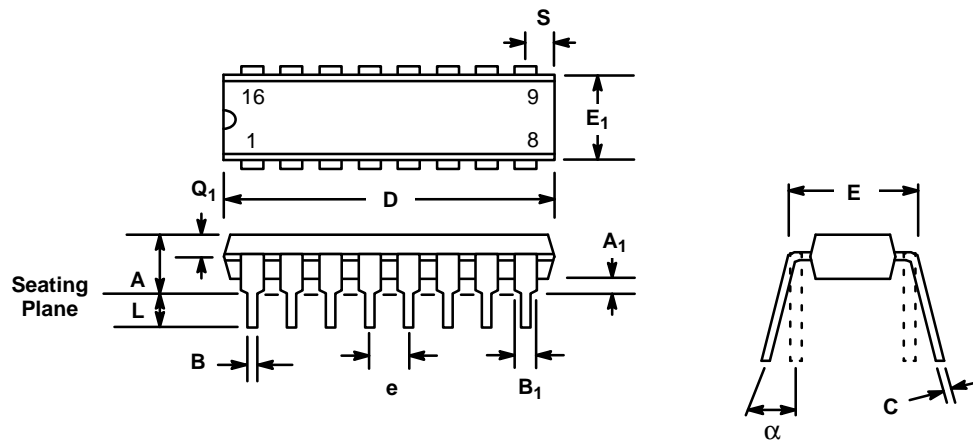

Figure 3. Digitally Programmable Gain Amplifier



Graph 1. Relative Accuracy vs. Digital Code

16 LEAD PLASTIC DUAL-IN-LINE (300 MIL PDIP) N16



SYMBOL	INCHES		MILLIMETERS	
	MIN	MAX	MIN	MAX
A	—	0.200	—	5.08
A ₁	0.015	—	0.38	—
B	0.014	0.023	0.356	0.584
B ₁ (1)	0.038	0.065	0.965	1.65
C	0.008	0.015	0.203	0.381
D	0.745	0.785	18.92	19.94
E	0.295	0.325	7.49	8.26
E ₁	0.220	0.310	5.59	7.87
e	0.100 BSC		2.54 BSC	
L	0.115	0.150	2.92	3.81
α	0°	15°	0°	15°
Q ₁	0.055	0.070	1.40	1.78
S	0.020	0.080	0.51	2.03

Note: (1) The minimum limit for dimensions B1 may be 0.023" (0.58 mm) for all four corner leads only.

**16 LEAD CERAMIC DUAL-IN-LINE
(300 MIL CDIP)
D16**

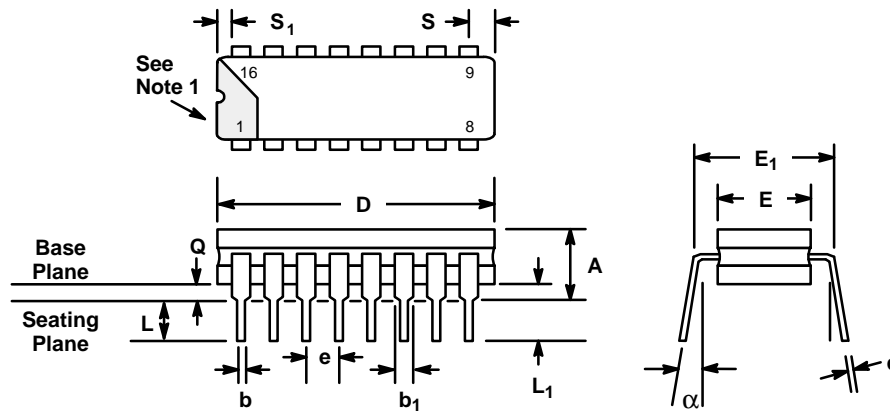

SYMBOL	INCHES		MILLIMETERS		NOTES
	MIN	MAX	MIN	MAX	
A	—	0.200	—	5.08	—
b	0.014	0.023	0.356	0.584	—
b ₁	0.038	0.065	0.965	1.65	2
c	0.008	0.015	0.203	0.381	—
D	—	0.840	—	21.34	4
E	0.220	0.310	5.59	7.87	4
E ₁	0.290	0.320	7.37	8.13	7
e	0.100 BSC		2.54 BSC		5
L	0.125	0.200	3.18	5.08	—
L ₁	0.150	—	3.81	—	—
Q	0.015	0.060	0.381	1.52	3
S	—	0.080	—	2.03	6
S ₁	0.005	—	0.13	—	6
α	0°	15°	0°	15°	—

NOTES

1. Index area; a notch or a lead one identification mark is located adjacent to lead one and is within the shaded area shown.
2. The minimum limit for dimension b₁ may be 0.023 (0.58 mm) for all four corner leads only.
3. Dimension Q shall be measured from the seating plane to the base plane.
4. This dimension allows for off-center lid, meniscus and glass overrun.
5. The basic lead spacing is 0.100 inch (2.54 mm) between centerlines.
6. Applies to all four corners.
7. This is measured to outside of lead, not center.

**16 LEAD SMALL OUTLINE
(300 MIL JEDEC SOIC)
S16**

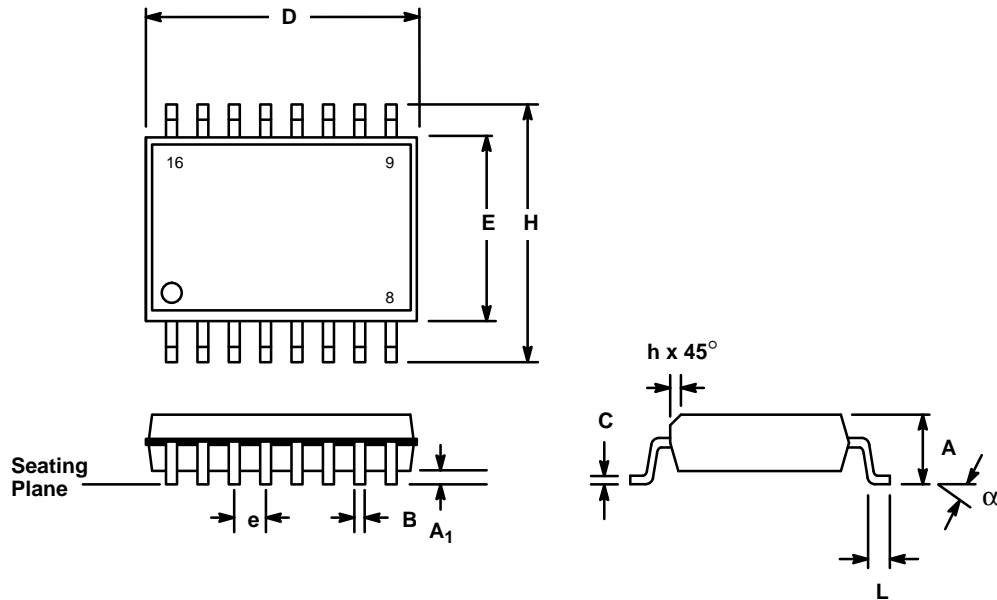

SYMBOL	INCHES		MILLIMETERS	
	MIN	MAX	MIN	MAX
A	0.097	0.104	2.46	2.64
A ₁	0.0050	0.0115	0.127	0.292
B	0.014	0.019	0.356	0.482
C	0.0091	0.0125	0.231	0.318
D	0.402	0.412	10.21	10.46
E	0.292	0.299	7.42	7.59
e	0.050 BSC		1.27 BSC	
H	0.400	0.410	10.16	10.41
h	0.010	0.016	0.254	0.406
L	0.016	0.035	0.406	0.889
α	0°	8°	0°	8°

**20 LEAD PLASTIC LEADED CHIP CARRIER
(PLCC)
P20**

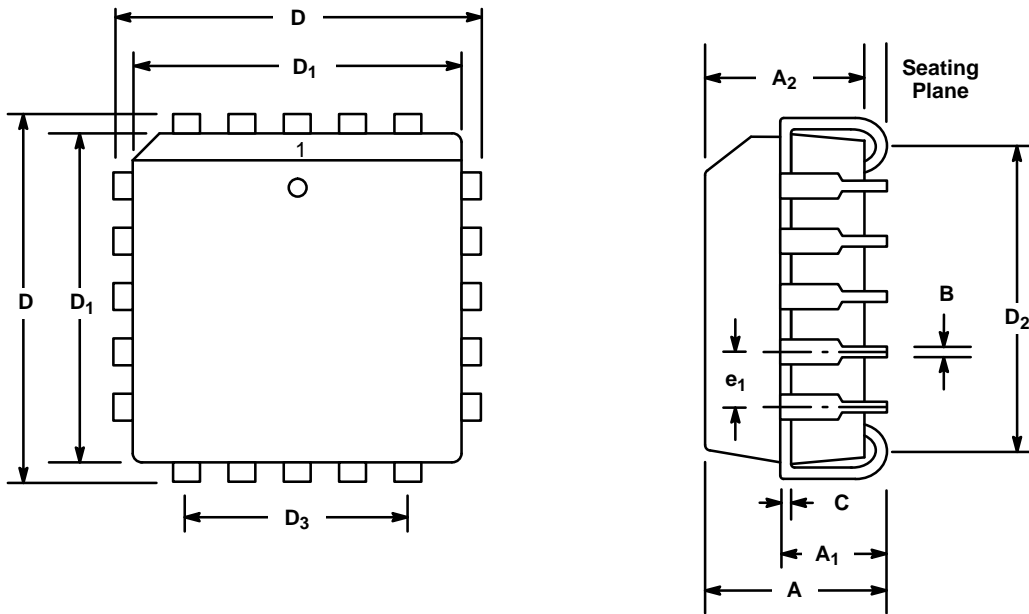

SYMBOL	INCHES		MILLIMETERS	
	MIN	MAX	MIN	MAX
A	0.165	0.180	4.19	4.57
A ₁	0.100	0.110	2.54	2.79
A ₂	0.148	0.156	3.76	3.96
B	0.013	0.021	0.330	0.533
C	0.008	0.012	0.203	0.305
D	0.385	0.395	9.78	10.03
D ₁ (1)	0.350	0.354	8.89	8.99
D ₂	0.290	0.330	7.37	8.38
D ₃	0.200 Ref		5.08 Ref.	
e ₁	0.050 BSC		1.27 BSC	

Note: (1) Dimension D₁ does not include mold protrusion.
Allowed mold protrusion is 0.254 mm/0.010 in.

NOTICE

EXAR Corporation reserves the right to make changes to the products contained in this publication in order to improve design, performance or reliability. EXAR Corporation assumes no responsibility for the use of any circuits described herein, conveys no license under any patent or other right, and makes no representation that the circuits are free of patent infringement. Charts and schedules contains here in are only for illustration purposes and may vary depending upon a user's specific application. While the information in this publication has been carefully checked; no responsibility, however, is assumed for inaccuracies.

EXAR Corporation does not recommend the use of any of its products in life support applications where the failure or malfunction of the product can reasonably be expected to cause failure of the life support system or to significantly affect its safety or effectiveness. Products are not authorized for use in such applications unless EXAR Corporation receives, in writing, assurances to its satisfaction that: (a) the risk of injury or damage has been minimized; (b) the user assumes all such risks; (c) potential liability of EXAR Corporation is adequately protected under the circumstances.

Copyright EXAR Corporation

Datasheet April 1995

Reproduction, in part or whole, without the prior written consent of EXAR Corporation is prohibited.