



OXFW911

IEEE1394 to ATA/ATAPI Native Bridge

Data Sheet

FEATURES

- S400 (50 Mbytes/s) compliant 1394-1995 Link and Transaction layers
- Compatible with 1394-1995 and 1394A Phys.
- Microsoft Win98-Second Edition, Win2000 and Apple MacOS generic driver support
- SBP-2 Target Revision 4 compliant interface
- Fully ATA-5 compliant (see T13-1321D)
- Support for UDMA5 (ATA100)
- Sustained data transfer of 35 MB/s
- Supports PIO modes 0 to 4, DMA modes 0 to 2 and Ultra DMA modes 0 to 5
- ORB co-processor to accelerate translation of ORBs to ATAPI commands
- Supports ORB chaining for increased performance
- High performance ATA command translation in firmware using Reduced Block Command (RBC) set
- Integrated 32-bit RISC processor (ARM7TDMI) with on-chip scratch RAM
- Optional External Serial ROM interface for configuration data, user serial number, etc.
- Integrated 512kb Flash memory
- Blank Flash memory programming feature via 1394 bus
- Firmware and Flash Programming Utilities supplied by Oxford Semiconductor
- 3.3 Volts operation
- Low Power CMOS
- Ultra-thin 128-TQFP package (14 x 14 x 1 mm)

DESCRIPTION

The OXFW911 is a high-performance 1394 to ATA/ATAPI (IDE) native bridge with an integrated target Serial Bus Protocol (SBP-2) controller. By supporting the SBP-2 protocol, the device can use generic SBP-2 drivers available in the Microsoft Windows 98SE, Microsoft Windows 2000, Microsoft Millennium and Apple MacOS (8.4 to 9.04) operating systems. MacOS support also includes booting from Firewire disk.

The device is ideally suited for smart-cable or tailgate interface applications for removable-media drives, compact flash card readers, CD-ROM, CD-R, CD-RW, DVD-ROM, DVD-RAM and hard disk drives, allowing IDE drives to be connected to a 1394 serial bus in a plug-and-play fashion. Both ATA and ATAPI devices are supported using the same firmware.

This highly integrated device offers a two-chip solution to native bridge applications using an external 1394 PHY. The device is compatible with both 1394-1995 and 1394A PHYs.

The LINK controller complies with 1394-1995 and 1394A specifications. The 1394 transaction layer and SBP-2 protocol is implemented using a combination of the ARM7TDMI (low-power 32-bit RISC processor), an ORB (Operational Request Block) hardware co-processor and a high performance buffer manager.

The buffer manager has a RAM bandwidth of 800Mbps. It provides storage for 1394 and ATA/ATAPI packets,

automatically storing them and passing them to the appropriate destinations, without any intervention from the processor. It also provides storage and manages the sequencing of ORB fetching to reduce latency and improve data throughput.

The configuration data including the IEEE OUI (Organisational Unique Identifier) and device serial number is stored in the Flash ROM which may be uploaded from the 1394 bus, even when blank. The device also facilitates firmware uploads from the 1394 bus.

The ORB co-processor translates ORBs as defined in the SBP-2 protocol into ATA/ATAPI commands, and automatically stores error/status messages at an address specified by the host.

Concurrent operation of the ATA/ATAPI and 1394 interfaces are facilitated using the high throughput buffer manager where LINK, ATAPI manager and ARM7TDMI can perform interleaved accesses to the on-chip RAM buffer. The high performance processor ensures that no significant latency is incurred. The ATA command translation is performed in firmware to meet RBC (Reduced Block Commands) standard, T10-1228D. The ATA/ATAPI Manager supports PIO modes 0 to 4, DMA modes 0 to 2 and Ultra DMA mode 0 to 5 and provides the interface to the IDE bus. It is compliant with T13-1321D, ATA-5 specification, as well as support for ATA100.



CONTENTS

FEATURES.....	1
DESCRIPTION	1
CONTENTS.....	2
1 BLOCK DIAGRAM.....	3
2 PIN INFORMATION	4
3 PIN DESCRIPTIONS.....	5
4 OPERATING CONDITIONS	7
5 DC ELECTRICAL CHARACTERISTICS	7
5.1 I/O BUFFERS	7
6 AC ELECTRICAL CHARACTERISTICS	8
6.1 IDE INTERFACE	8
6.2 1394 LINK-PHY INTERFACE	11
6.3 EXTERNAL PROCESSOR INTERFACE.....	13
7 TIMING WAVEFORMS.....	14
8 PACKAGE INFORMATION	29
9 ORDERING INFORMATION	29
NOTES	31
CONTACT DETAILS.....	32
DISCLAIMER	32

1 BLOCK DIAGRAM

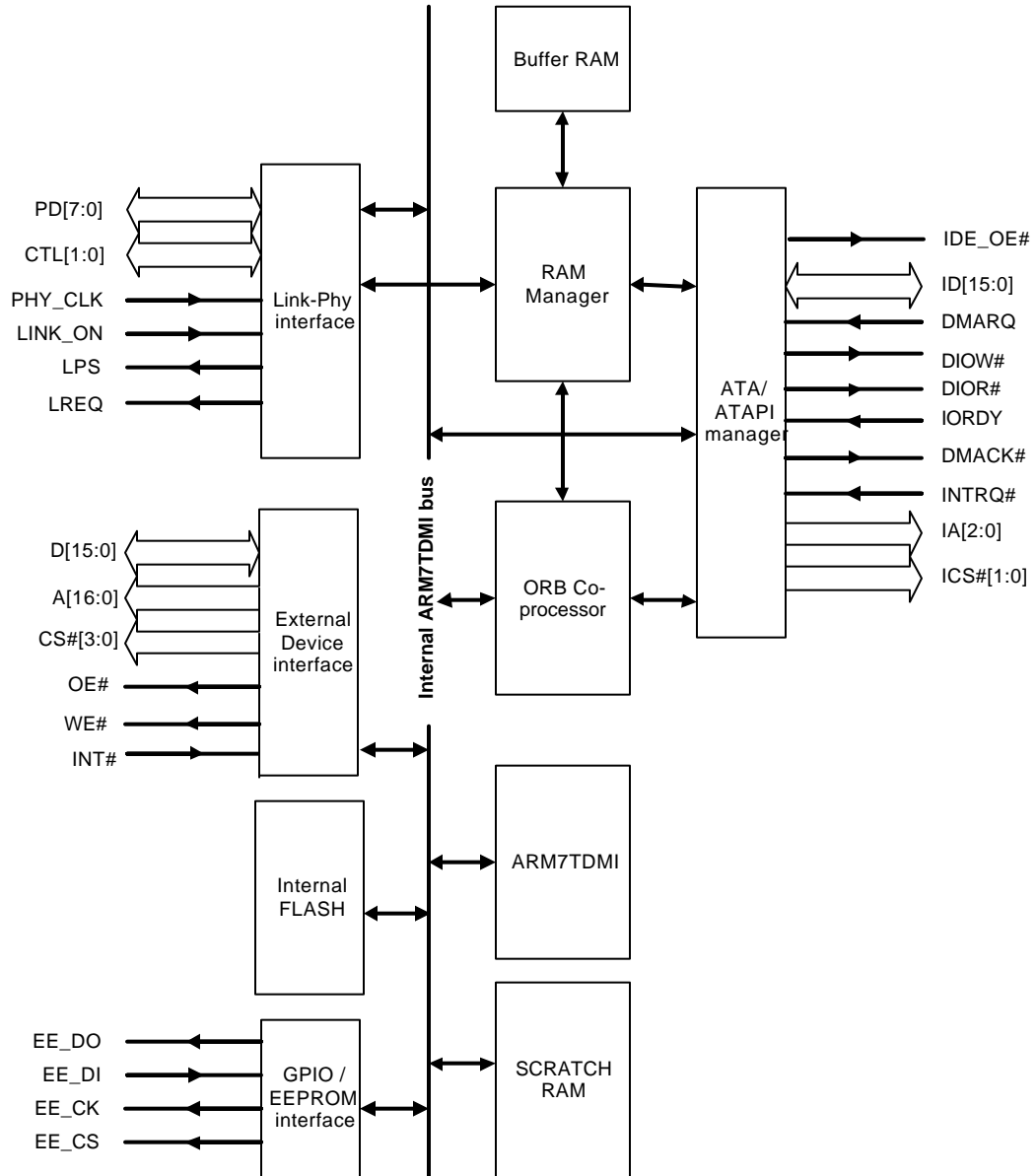

Figure 1: OXFW911 Block Diagram

2 PIN INFORMATION

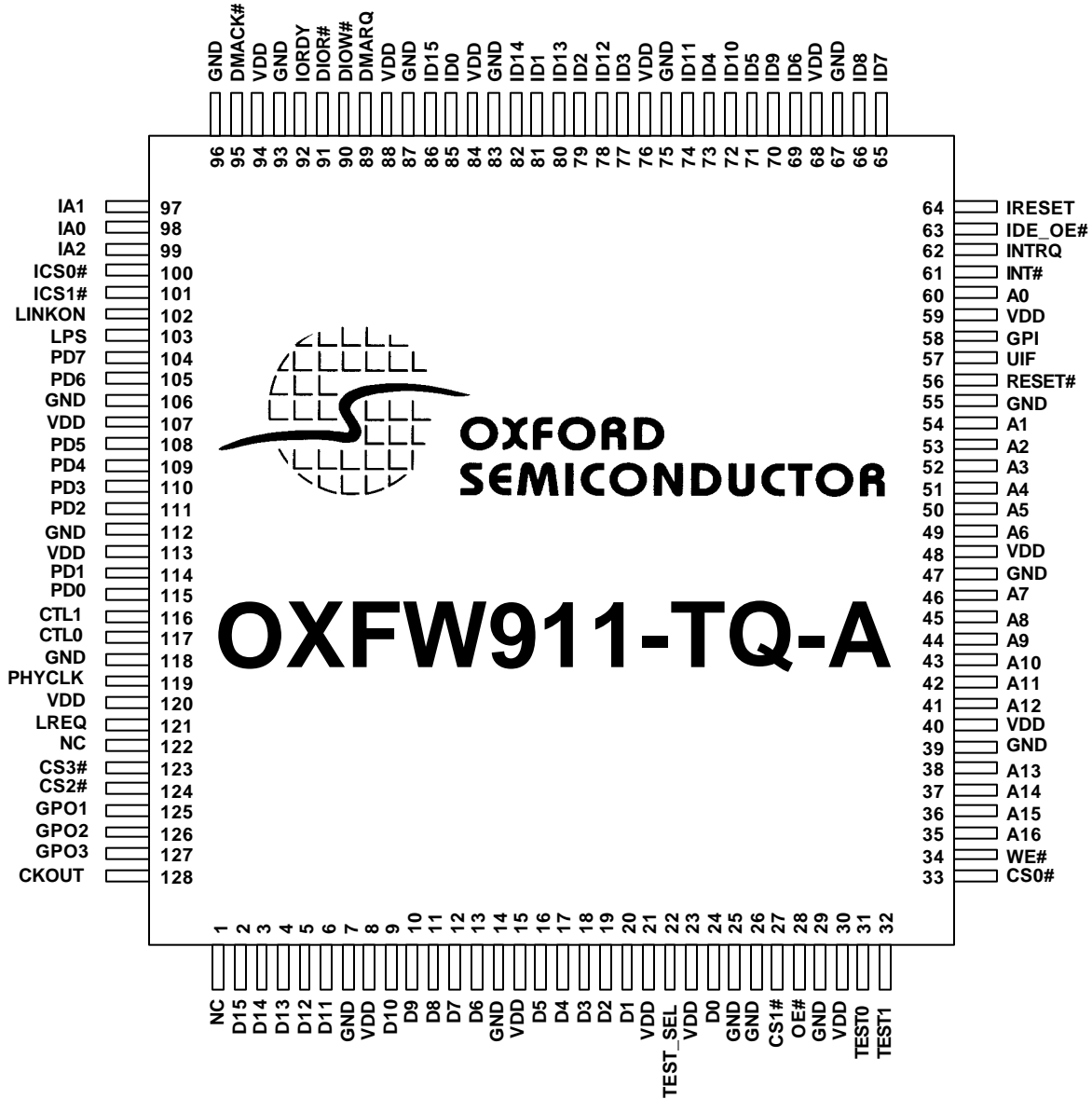

Figure 2: Pinout (package = 128 TQFP)

3 PIN DESCRIPTIONS

	Dir ¹	Name	Description
1394 PHY-LINK interface			
104, 105, 108, 109, 110, 111, 114, 115	I/O	PD[7:0]	Phy-Link Data Bus
116, 117	I/O	CTL[1:0]	Phy-Link Control Bus
119	I	PHYCLK	49.152 MHz clock sourced by PHY
121	O	LREQ	Link Request
102	IU	LINKON	Requests link to power up when in a low power mode
103	O	LPS	Indicates to phy that link is powered and ready
ARM external interface			
2, 3, 4, 5, 6, 9, 10, 11, 12, 13, 16, 17, 18, 19, 20, 24	T_I/O	D[15:0]	ARM external data bus
35, 36, 37, 38, 41, 42, 43, 44, 45, 46, 49, 50, 51, 52, 53, 54, 60	T_O	A[16:0]	ARM external address bus
123, 124, 27, 33	T_O	CS#[3:0]	ARM external chip selects. CS0# is always used for program ROM.
28	T_O	OE#	ARM external output enable. Active when reading data from external devices including program ROM
34	T_O	WE#	Write Enable. Active when writing to external devices
61	T_IU	INT#	External ARM interrupt
IDE interface			
86, 82, 80, 78, 74, 72, 70, 66, 65, 69, 71, 73, 77, 79, 81, 85	T_I/O	ID[15:0]	IDE data bus
99, 97, 98	T_O	IA[2:0]	IDE address bus
101, 100	T_O	ICS#[1:0]	IDE chip select. Used to select the Command Block or Control Block registers.
63	T_O	IDE_OE#	IDE output enable. Only used when external buffering is required to drive IDE data bus
64	T_O	IRESET	IDE interface reset
89	T_I	DMARQ	
90	T_O	DIOW#	IDE interface write strobe
91	T_O	DIOR#	IDE interface read strobe
92	T_O	IORDY	
95	T_O	DMACK#	
62	T_I	INTRQ	
EEPROM interface			
125	O	GPO1	General Purpose Output 1
126	O	GPO2	General Purpose Output 2
127	O	GPO3	General Purpose Output 3
58	T_IU	GPI	General Purpose Input
Miscellaneous Pins			
56	IU	RESET#	Global reset for the OXFW911. Active Low.
128	T_O	CKOUT	Clock output. 49.152 MHz clock output.
22, 32, 31	I	TEST_SEL, TEST[1:0]	'100' = NORMAL OPERATION. Other settings are for foundry test purposes only.
57	IU	UIF	Leave unconnected to use internal Flash, tie low to use only external device
Power and ground²			
15, 8, 40, 48, 59, 76, 94, 107, 113	VDD	AC VDD	Supplies power to output buffers in switching (AC) state
30, 21, 23, 68, 84, 88, 120	VDD	DC VDD	Power supply. Supplies power to core logic, input buffers and output buffers in steady state

14, 7, 39, 47, 55, 67, 75, 93, 96, 106, 112,	GND	AC GND	Supplies GND to output buffers in switching (AC) state
29, 25, 26, 83, 87, 118	GND	DC GND	Ground (0 volts). Supplies GND to core logic, input buffers and output buffers in steady state
Other			
1, 122	NC		No Connect

Table 1: Pin Descriptions

Note 1: Direction key:

I	Input	T_O	5V tolerant output
IU	Input with internal pull-up	T_I/O	5V tolerant bi-directional
ID	Input with external pull-down	GND	Ground
O	Output	VDD	3.3V power
I/O	Bi-directional	NC	No Connect
T_I	5V tolerant input		

Note 2: Power & Ground

There are two GND and two VDD rails internally. One set of rails supply power and ground to output buffers while in switching state (called AC power) and another rail supply the core logic, input buffers and output buffers in steady-state (called DC rail).

The rails are not connected internally. This precaution reduces the effects of simultaneous switching outputs and undesirable RF radiation from the chip.

Configuration & Operation

4 OPERATING CONDITIONS

Symbol	Parameter	Min	Max	Units
V _{DD}	DC supply voltage	-0.3	3.8	V
V _{IN}	DC input voltage (3.3V IO)	-0.3	V _{DD} + 0.3	V
V _{IN}	DC input voltage (5V tolerant IO)	-0.3	5.5	V
I _{IN}	DC input current		+/- 10	mA
T _{STG}	Storage temperature	-40	125	°C

Table 2: Absolute maximum ratings

Symbol	Parameter	Min	Max	Units
V _{DD}	DC supply voltage	3.15	3.6	V
T _C	Temperature	0	70	°C

Table 3: Recommended operating conditions

5 DC ELECTRICAL CHARACTERISTICS

5.1 I/O Buffers

Symbol	Parameter	Condition	Min	Max	Units
V _{DD}	Supply voltage	Commercial	3.0	3.6	V
V _{IH}	Input high voltage	CMOS Interface CMOS Schmitt trig	2.0 2.0		V
V _{IL}	Input low voltage	CMOS Interface ¹ CMOS Schmitt trig		0.8 0.8	V
C _{IL}	Cap of input buffers			4.0	pF
C _{OL}	Cap of output buffers			4.0	pF
I _{IH}	Input high leakage current	V _{in} = V _{DD}	-10	10	μA
I _{IL}	Input low leakage current	V _{in} = V _{SS}	-10	10	μA
V _{OH}	Output high voltage	I _{OH} = -1 μA	V _{DD} - 0.05		V
V _{OH}	Output high voltage	I _{OH} = -1mA to -24mA	2.4		V
V _{OL}	Output low voltage	I _{OL} = 1 μA		0.05	V
V _{OL}	Output low voltage	I _{OL} = 1mA to 24mA		0.4	V
I _{OZ}	3-state output leakage current		-10	10	μA

Symbol	Parameter	Condition	Typical	Max	Units
I _{CC}	Operating supply current in normal mode	V _{DD} = 3.3V	85	TBD	mA
		T = 25°C			
	Operating supply current in Power-down mode				

Table 4: Characteristics of OXFW911 I/O buffers

6 AC ELECTRICAL CHARACTERISTICS

6.1 IDE interface

Symbol	Parameter	Mode 0	Mode 1	Mode 2	Mode 3	Mode 4	Units
t0	Cycle Time	600	400	360	200	120	ns
t1	Address Valid to DIOR# / DIOW# setup	80	80	40	40	40	ns
t2	DIOR# / DIOW# pulse width	320	320	320	80	80	ns
t2i	DIOR# / DIOW# recovery time	-	-	-	80	40	ns
t3	DIOW# data setup (min)	60	45	30	30	20	ns
t4	DIOW# data hold	40	40	40	40	40	ns
t5	DIOR# data setup (min)	50	35	20	20	20	ns
t6	DIOR# data hold (min)	5	5	5	5	5	ns
t6z	DIOR# data tristate (max)	30	30	30	30	30	ns
t9	DIOR# / DIOW# to address valid hold	40	40	40	40	40	ns
tRD	Read Data Valid to IORDY active if IORDY initially low after tA	0	0	0	0	0	ns
tA	IORDY Setup time	35	35	35	35	35	ns
tB	IORDY Pulse Width (max)	1250	1250	1250	1250	1250	ns
tA	IORDY assertion to release	5	5	5	5	5	ns

Table 5: OXFW911 IDE PIO / Register Transfers

Symbol	Parameter	Mode 0	Mode 1	Mode 2	Units
t ₀	Cycle time	480	160	120	ns
t _D	DIOR# / DIOW#	240	80	80	ns
t _E	DIOR# data access (max)	150	60	50	ns
t _F	DIOR# data hold (min)	5	5	5	ns
t _G	DIOR# / DIOW# data setup	100	30	20	ns
t _H	DIOW# data hold	20	15	10	ns
t _I	DMACK to DIOR# / DIOW# setup (min)	0	0	0	ns
t _J	DIOR# / DIOW# to DMACK hold (min)	20	5	5	ns
t _{Kr}	DIOR# negated pulse width	80	80	40	ns
t _{Kw}	DIOW# negated pulse width	240	80	40	ns
t _{Lr}	DIOR# to DMARQ delay (max)	120	40	35	ns
t _{Lw}	DIOW# to DMARQ delay (max)	40	40	35	ns
t _M	IDCS[1:0] valid to DIOR# / DIOW#	80	40	40	ns
t _N	IDCS[1:0] hold	40	40	40	ns
t _Z	DMACK to tristate (max)	20	25	25	ns

Table 6: OXFW911 Multiword DMA timings

Symbol	Parameter	Mode 0 min	Mode 0 max	Mode 1 min	Mode1 max	Mode 2 min	Mode 2 max	Units
t2cyc	Typical sustained average two cycle time	240		160		120		ns
tcyc	Cycle time allowing for clock variations (refer to ATA spec)	112		75		55		ns
t2cyc	Two cycle time allowing for clock variations (refer to ATA spec)	230		156		117		ns
tds	Data setup time at recipient	15		10		7		ns
tdh	Data hold time at recipient	5		5		5		ns
tdvs	Data valid setup time at sender (from data bus being valid until STROBE edge)	70		48		34		ns
tdvh	Data valid hold time at sender (from STROBE edge until data may become invalid	6		6		6		ns
tfs	First STROBE time (for device to first negate DSTROBE from STOP during a data-in burst)	0	230	0	200	0	170	ns
tli	Limited interlock time	0	150	0	150	0	150	ns
tmll	Interlock time with minimum	20		20		20		ns
tui	Unlimited interlock time	0		0		0		ns
taz	Maximum time allowed for output drivers to release (from being asserted or negated)		10		10		10	ns
tzah	Minimum delay time required for output drivers to assert or negate (from released state)	20		20		20		ns
tzad		0		0		0		
tenv	Envelope time (from DMACK# to STOP and HDMARDY# during data-out burst initiation	20	70	20	70	20	70	ns
tsr	STROBE to DMARDY time (refer to ATA spec		50		30		20	ns
trfs	Ready-to-final-STROBE time (no STROBE edges shall be sent this long after the negation of DDMARDY#		75		70		60	ns
trp	Ready-to-pause time (time that recipient shall wait to initiate pause after negating DMARDY#)	160		125		100		ns
tiordyz	Pull-up time before allowing IORDY to be released		20		20		20	ns
tziordy	Minimum time a device shall wait before driving IORDY	0		0		0		ns
tack	Setup and hold times for DMACK# (before assertion or negation)	20		20		20		ns
tss	Time from STROBE edge to negation of DMARQ or assertion of STOP (when sender terminates a burst)	50		50		50		ns

Table 7: OXFW911 Ultra DMA timings

Symbol	Parameter	Mode 3 min	Mode 3 max	Mode 4 min	Mode 4 max	Mode 5 min	Mode 5 max	Unit s
t2cyc _{typ}	Typical sustained average two cycle time	100		60		40		ns
tcyc	Cycle time allowing for clock variations (refer to ATA spec)	39		25		20		ns
t2cyc	Two cycle time allowing for clock variations (refer to ATA spec)	86		57		40		ns
tds	Data setup time at recipient	7		5		4.0		ns
tdh	Data hold time at recipient	5		5		4.6		ns
tdvs	Data valid setup time at sender (from data bus being valid until STROBE edge)	20		6		4.8		ns
tdvh	Data valid hold time at sender (from STROBE edge until data may become invalid	6		6		4.8		ns
tfs	First STROBE time (for device to first negate DSTROBE from STOP during a data-in burst)	0	130	0	120	0	90	ns
tli	Limited interlock time	0	100	0	100	0	75	ns
tmli	Interlock time with minimum	20		20			20	ns
tui	Unlimited interlock time	0		0			0	ns
taz	Maximum time allowed for output drivers to release (from being asserted or negated)		10		10		10	ns
tzah	Minimum delay time required for output drivers to assert or negate (from released state)	20		20			20	ns
tzad		0		0			0	
tenv	Envelope time (from DMACK# to STOP and HDMARDY# during data-out burst initiation	20	55	20	55	20	50	ns
trfs	Ready-to-final-STROBE time (no STROBE edges shall be sent this long after the negation of DDMARDY#		60		60		50	ns
trp	Ready-to-pause time (time that recipient shall wait to initiate pause after negating DMARDY#)	100		100			85	ns
tiordyz	Pull-up time before allowing IORDY to be released		20		20		20	ns
tziordy	Minimum time a device shall wait before driving IORDY	0		0		0		ns
tack	Setup and hold times for DMACK# (before assertion or negation)	20		20		20		ns
tss	Time from STROBE edge to negation of DMARQ or assertion of STOP (when sender terminates a burst)	50		50		50		ns

Table 7a: OXFW911 Ultra DMA timings (cont)

6.2 1394 Link-Phy interface

The timings for 1394 Link – Phy are shown below :

Symbol	Parameter	Min	Max	Units
tl _{su}	Setup Time, PD[7:0] and CTL[1:0] before PhyClk	8		ns
tl _h	Hold Time, PD[7:0] and CTL[1:0] after PhyClk	0		ns
Tld1	Delay Time, PhyClk input high to initial instance of PD[7:0], CTL[1:0] and Lreq outputs valid	2	10	ns
Tld2	Delay Time, PhyClk input high to subsequent instance(s) of PD[7:0], CTL[1:0] and Lreq outputs valid	2	10	ns
Tld3	Delay Time, PhyClk input high to PD[7:0], CTL[1:0] and Lreq outputs invalid (high impedance)	2	10	ns
tcyc	Duty Cycle	45	55	%

Table 8: OXFW911 Link-Phy interface timings

6.3 External Processor Interface

Name	Description	min (ns)	max (ns)
	Common Timings		
tas	CSx# and OE# falling to valid Address	0	2
tws	Wait State Additional Delay (number of wait states (WS) * 20 ns)	20	300
taddr	Address Valid	60	40+tws
	Common Read Timings		
tah	Address hold after CSx# or OE# rising	0	-
tdsa	Data setup to CSx# and OE# rising	44	-
tdha	Data hold after CSx# and OE# rising	0	-
	Common Write Timings		
twds	Data valid to WE# rising	17	17+(tws-20)
twdh	Data hold after WE# rising	4	7
tcsw	CS# setup before WE# valid	7	9
tadw	Address setup before WE# valid	5	7
twe	WE# valid	20	20+tws

Table 9: External Processor Interface timings

7 TIMING WAVEFORMS

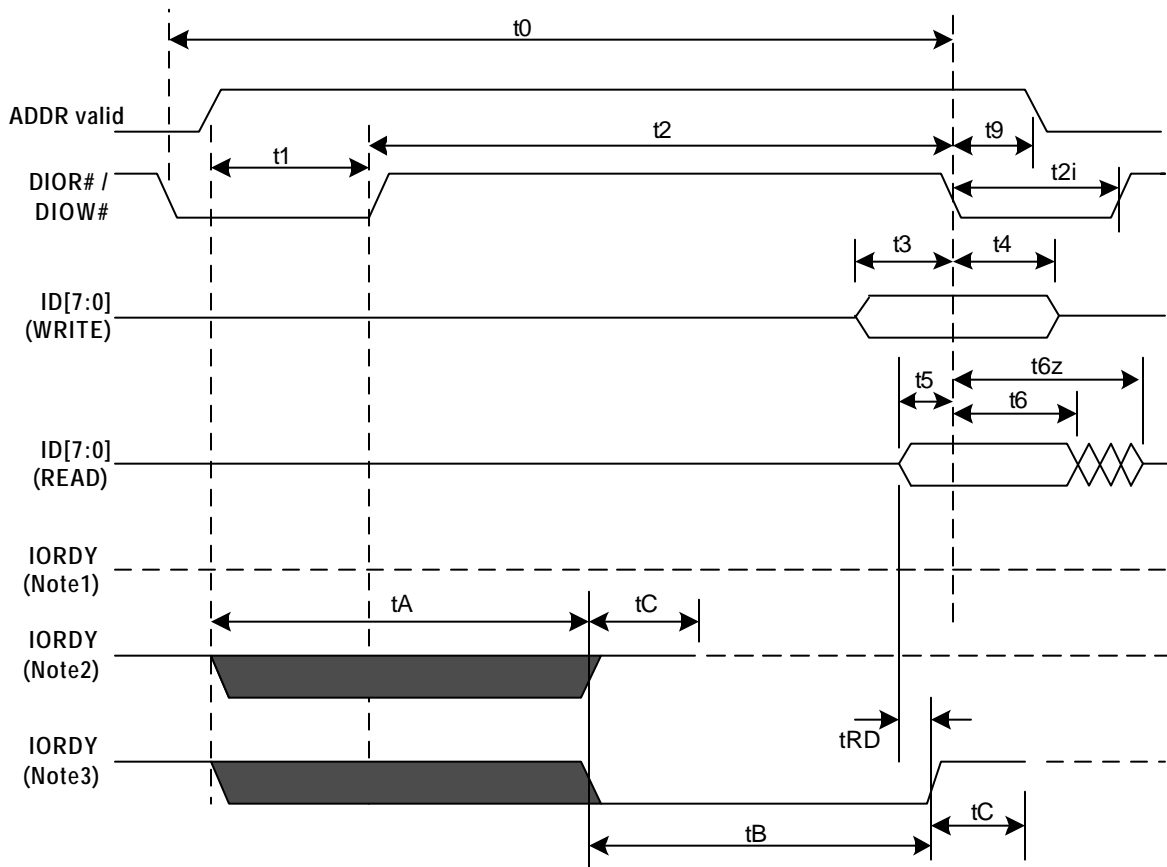

Figure 3: PIO / Register Transfer to / from IDE device

Notes : Negation of IORDY by the drive is used to extend the PIO cycle. The determination of whether the cycle is to be extended is made by the host after tA from the Assertion of DIOR# or DIOW#. The assertion and negation of IORDY are described in the following three cases : -

- 1) Device never negates IORDY and no wait is generated.
- 2) Device negates IORDY before tA, but causes IORDY to be asserted before tA. IORDY is released prior to negation and may be asserted for no more than 5ns before release : no wait generated.
- 3) Device negated IORDY before tA. IORDY is released prior to negation and may be asserted for no more than 5ns before release : wait generated. The cycle completes after IORDY is reasserted. For cycles where a wait is generated and DIOR# is asserted, the device shall place read data on DD[7:0] for tRD before asserting IORDY

TIMING WAVEFORMS

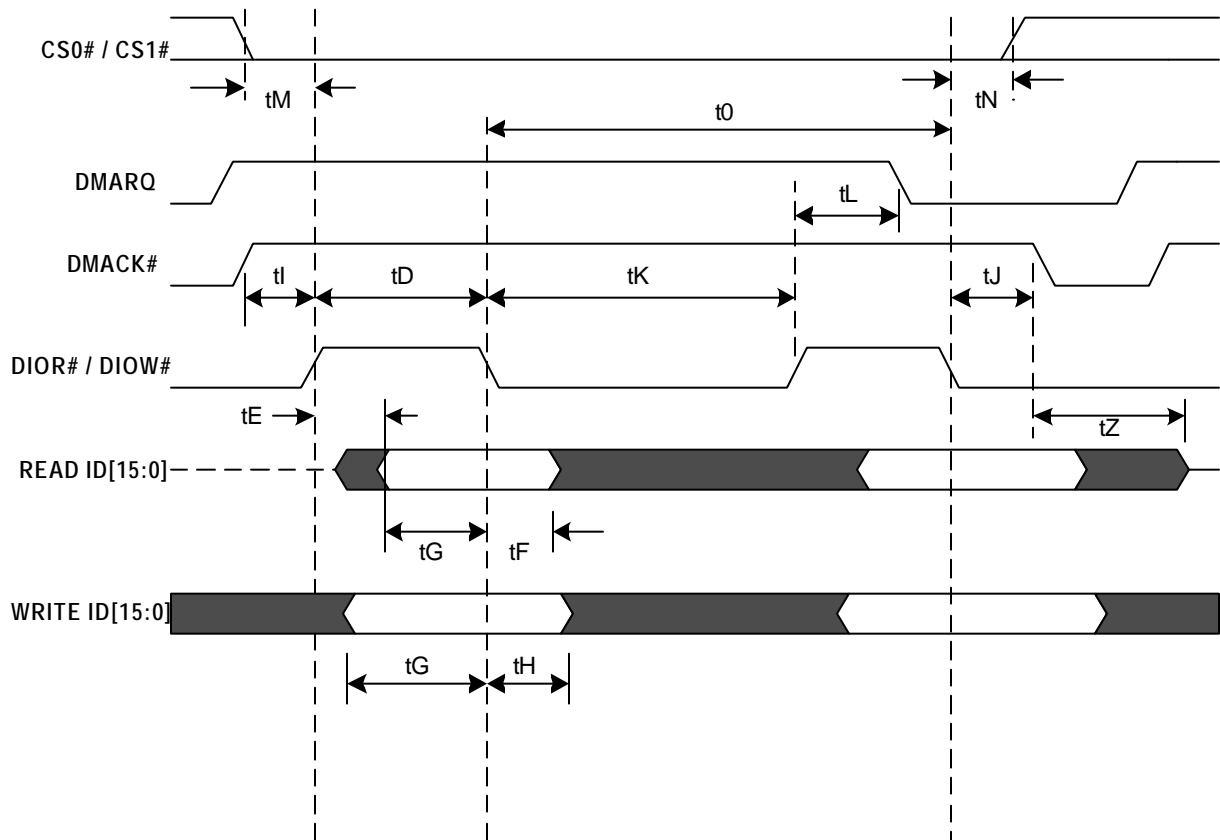

Figure 4: MultiWord DMA transfer to / from IDE device

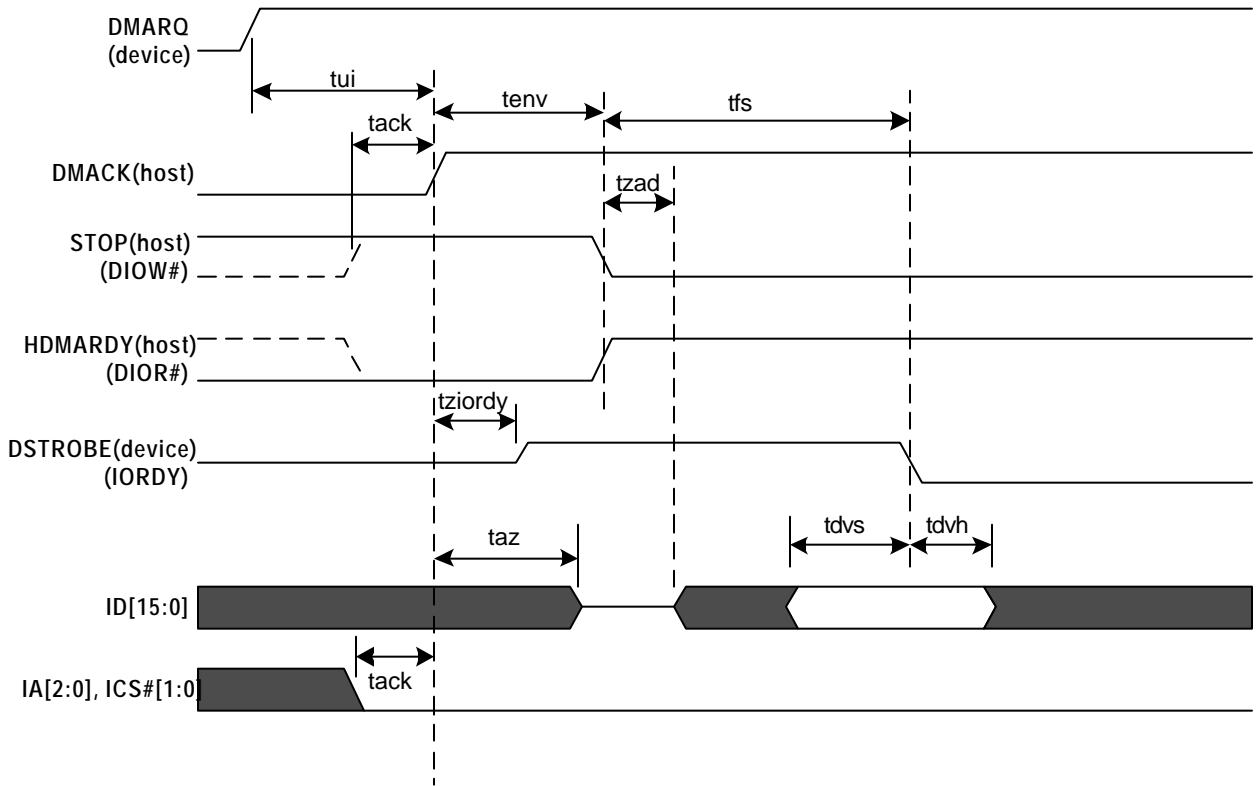

Figure 5: Initiating an Ultra DMA data-in burst

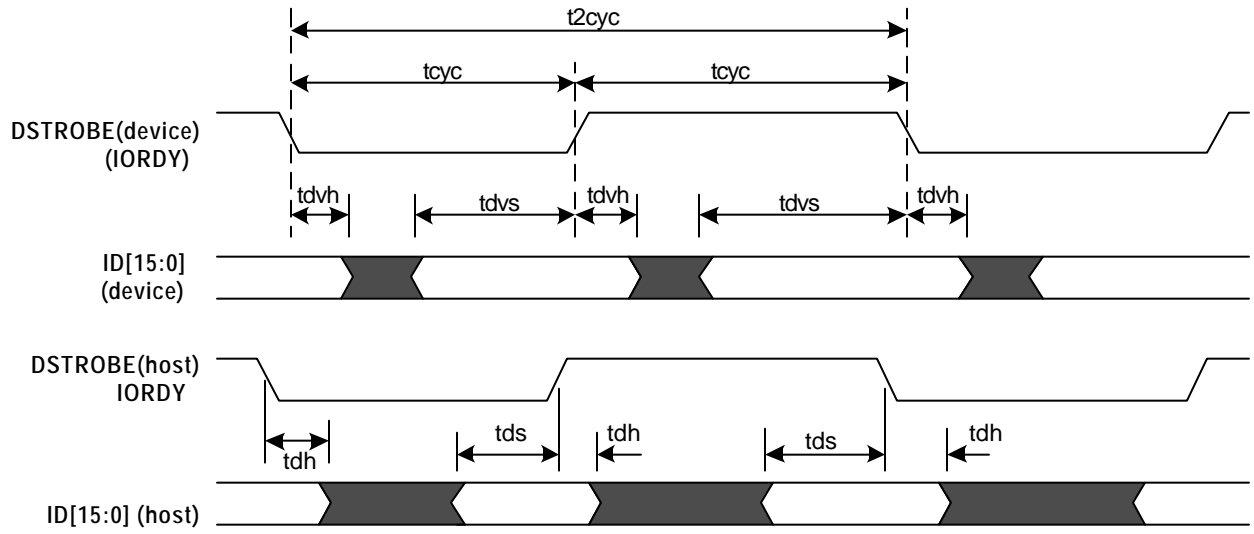

Figure 6: Sustained Ultra DMA data-in burst

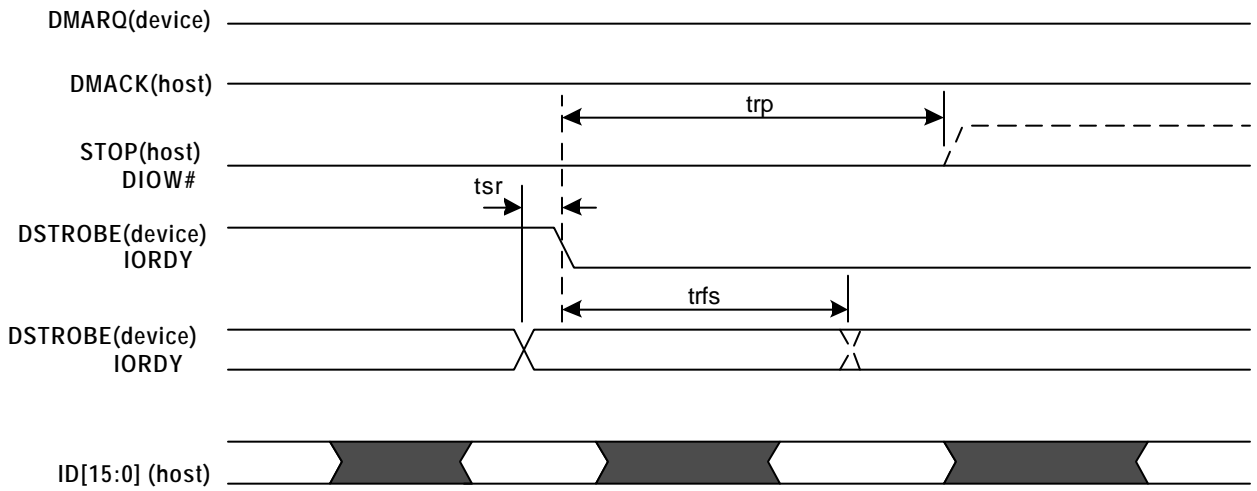

Figure 7: Host pausing an Ultra DMA data-in burst

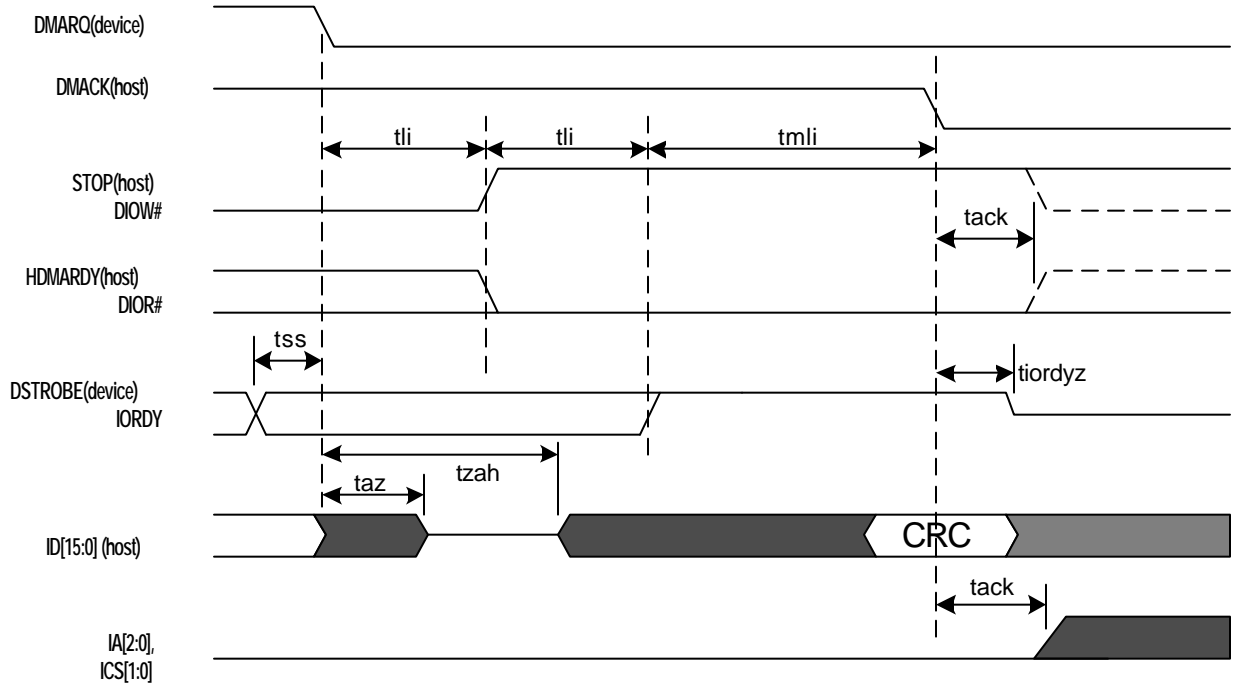

Figure 8: Device terminating an Ultra DMA data-in burst

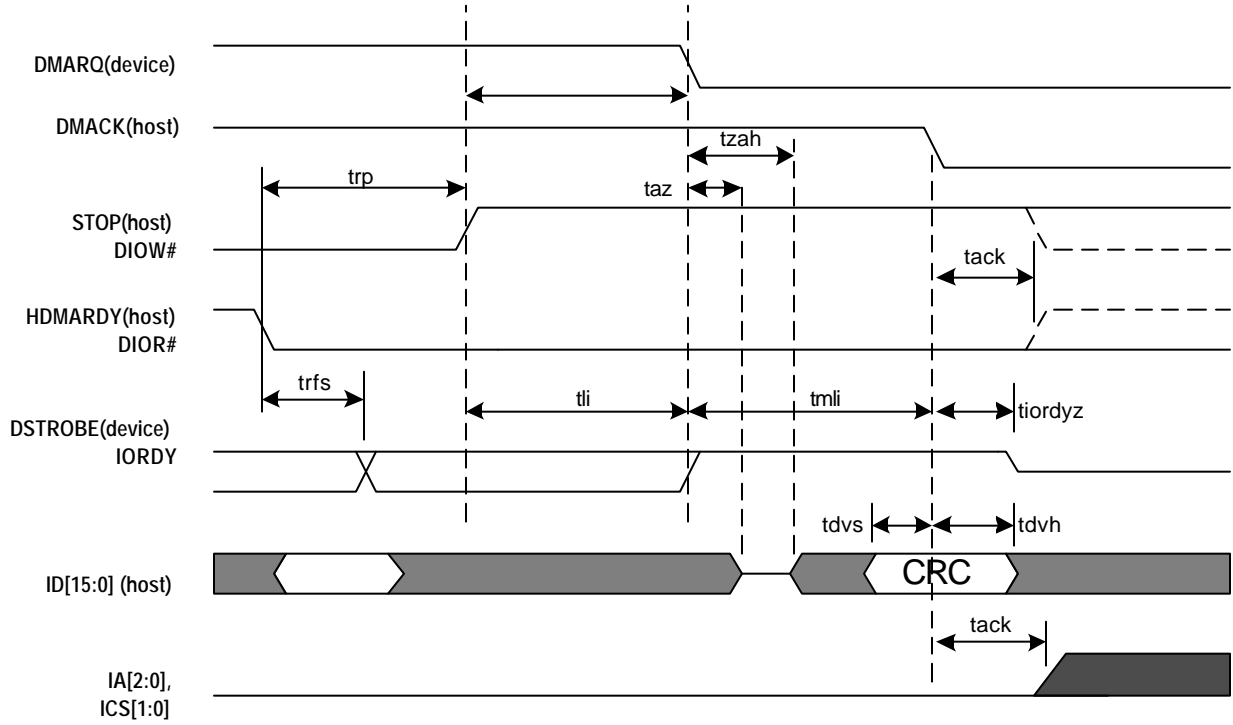

Figure 9: Host terminating an Ultra DMA data-in burst

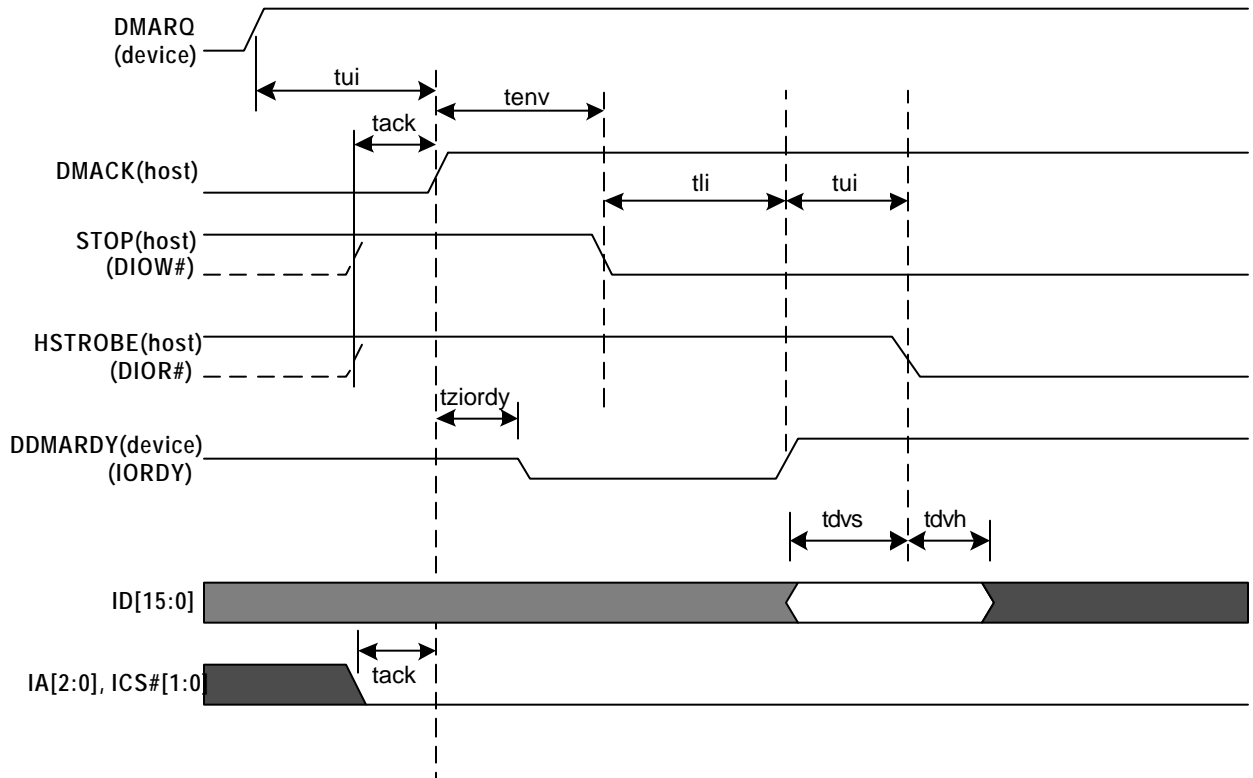

Figure 10: Initiating an Ultra DMA data-out burst

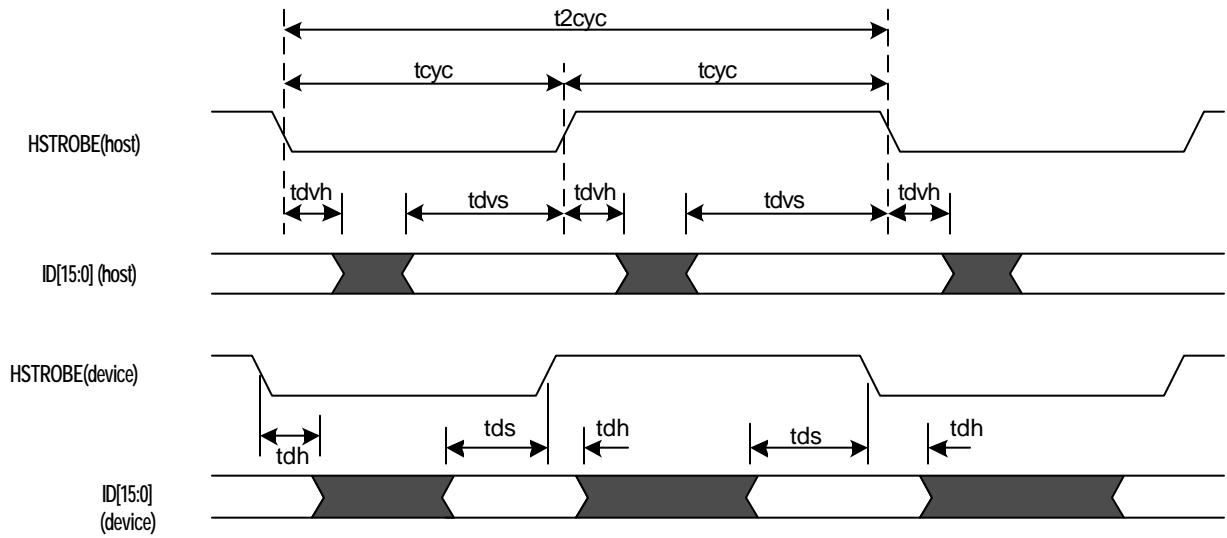

Figure 11: Sustained Ultra DMA data-out burst

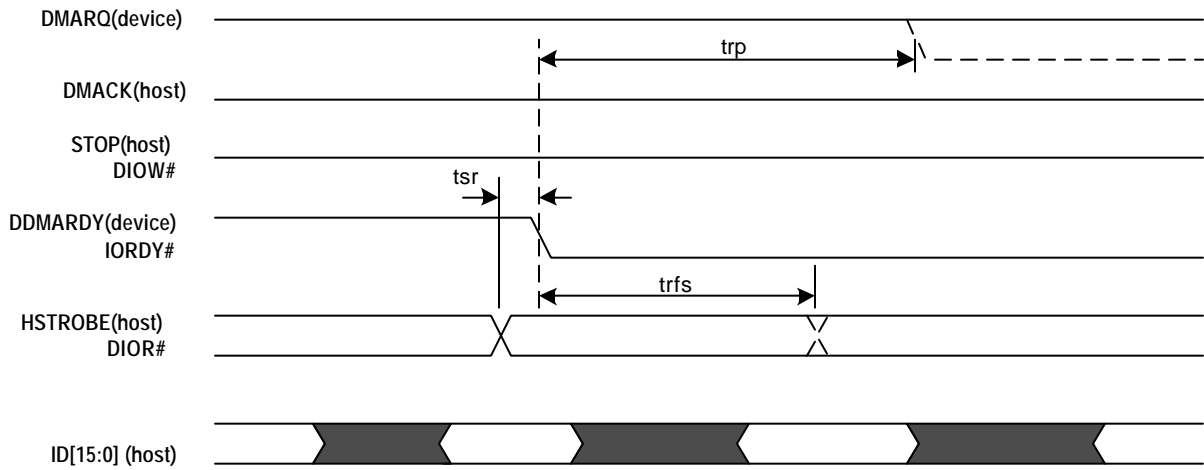

Figure 12: Device pausing an Ultra DMA data-in burst

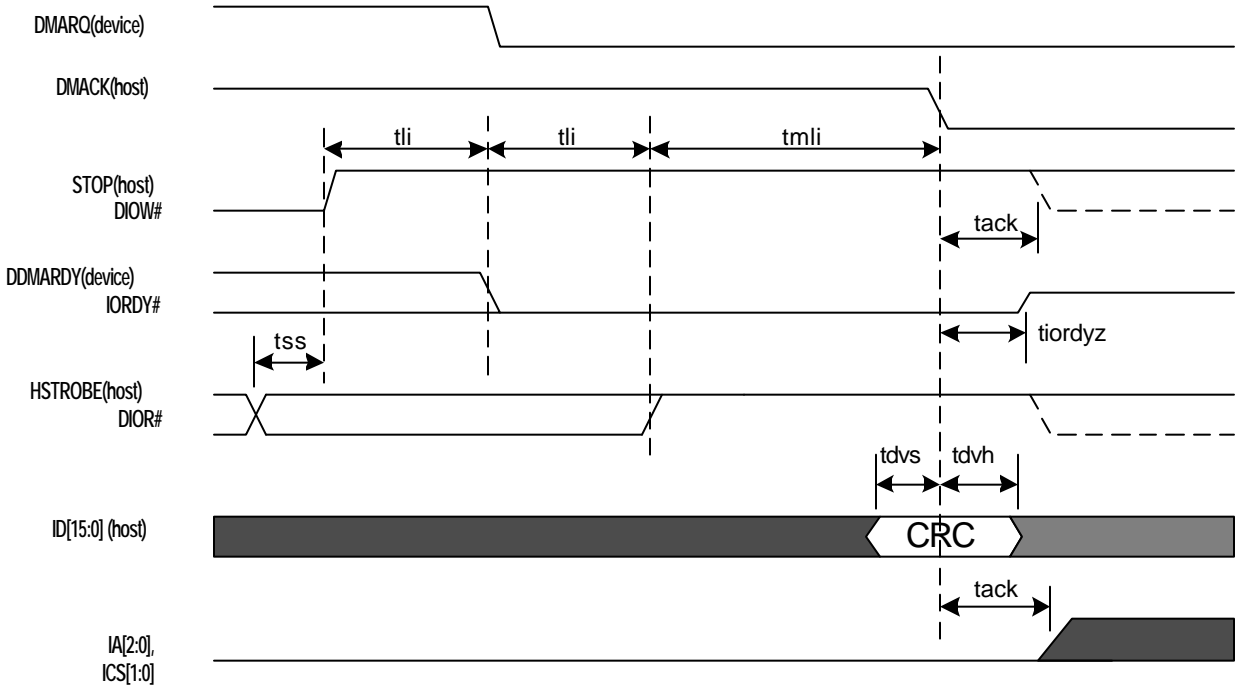

Figure 13: Host Terminating an Ultra DMA data-out burst

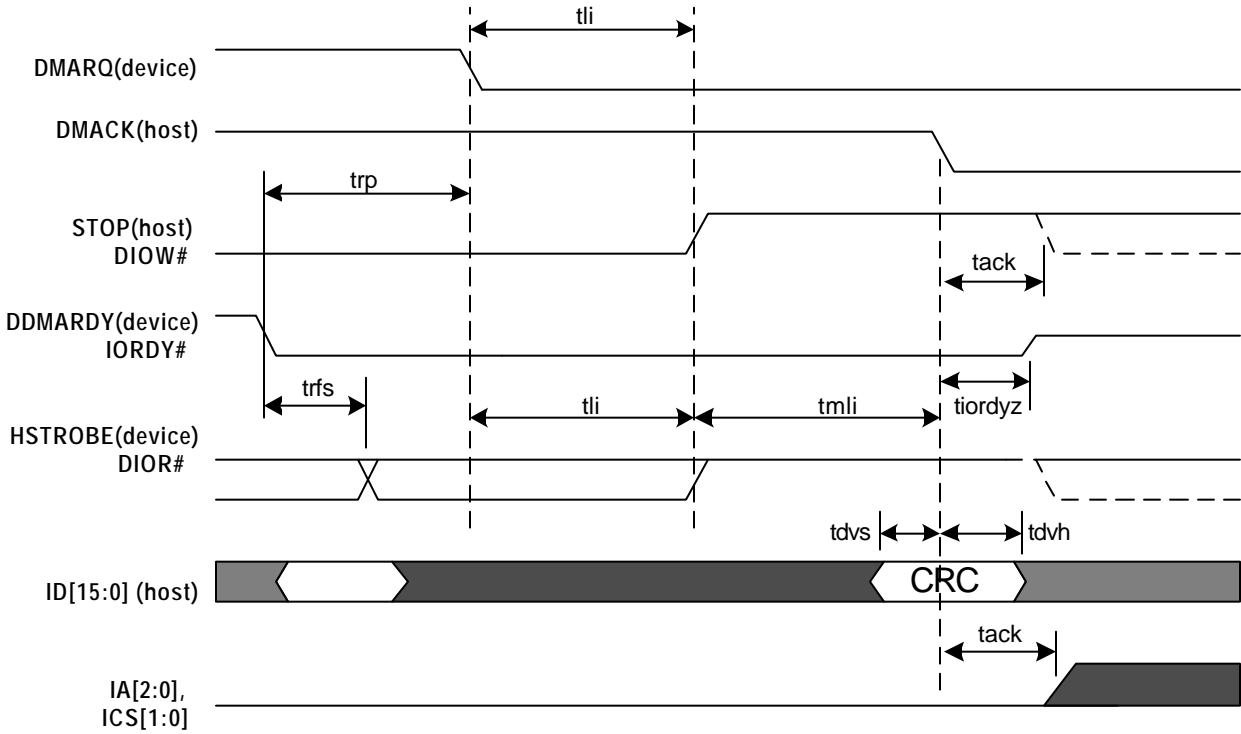

Figure 14: Device Terminating an Ultra DMA data-out burst

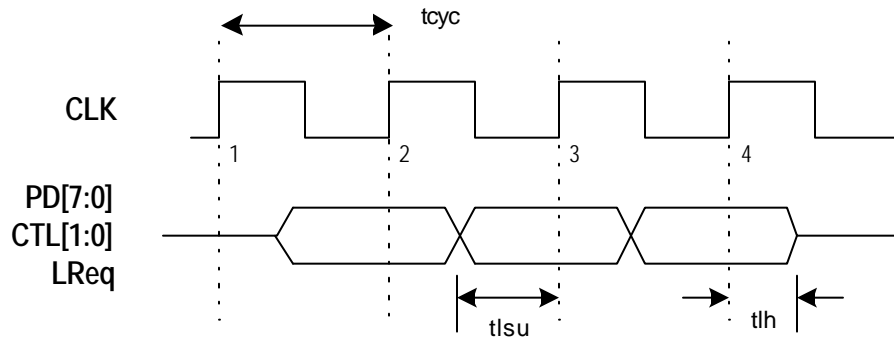

Figure 15: Phy to Link timings

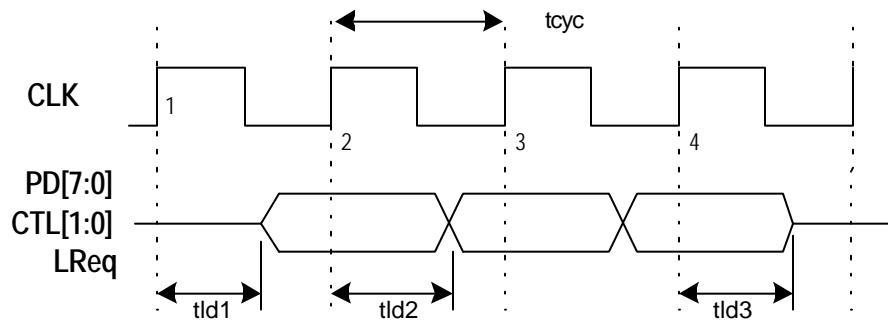

Figure 16: Link to Phy timings

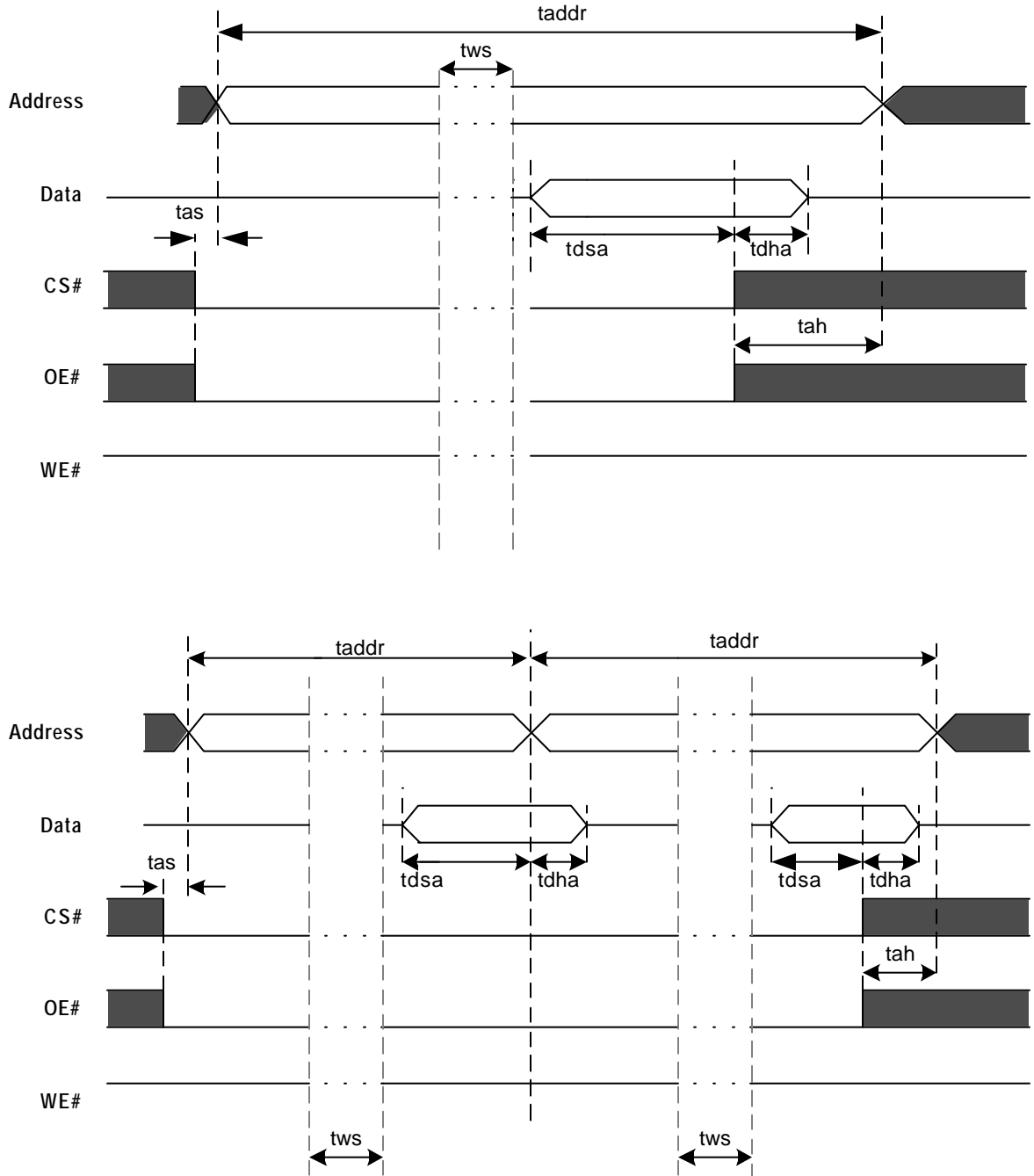

Figure 17: External Processor Bus read timings

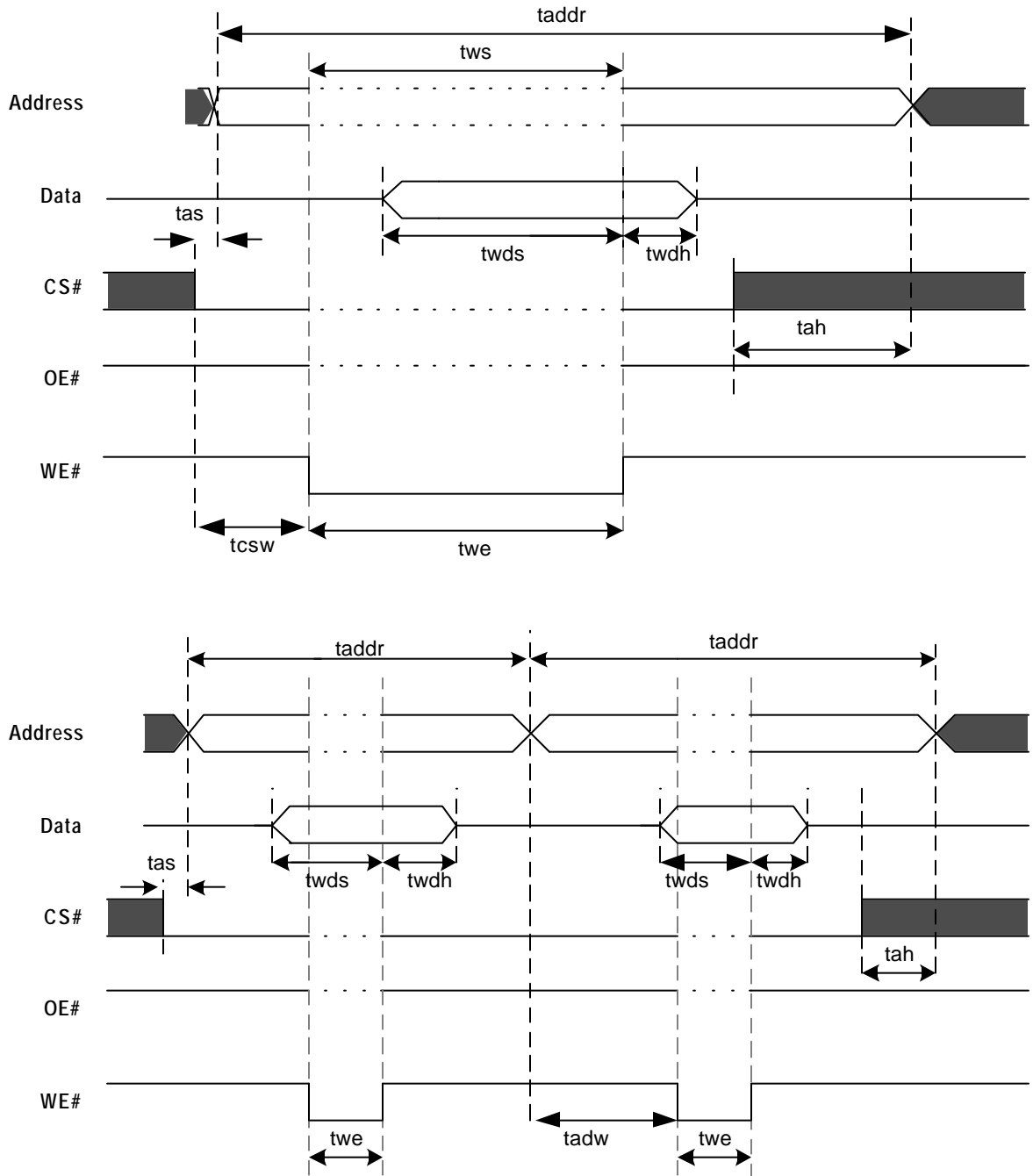

Figure 17a: External Processor Bus write timings

8 PACKAGE INFORMATION

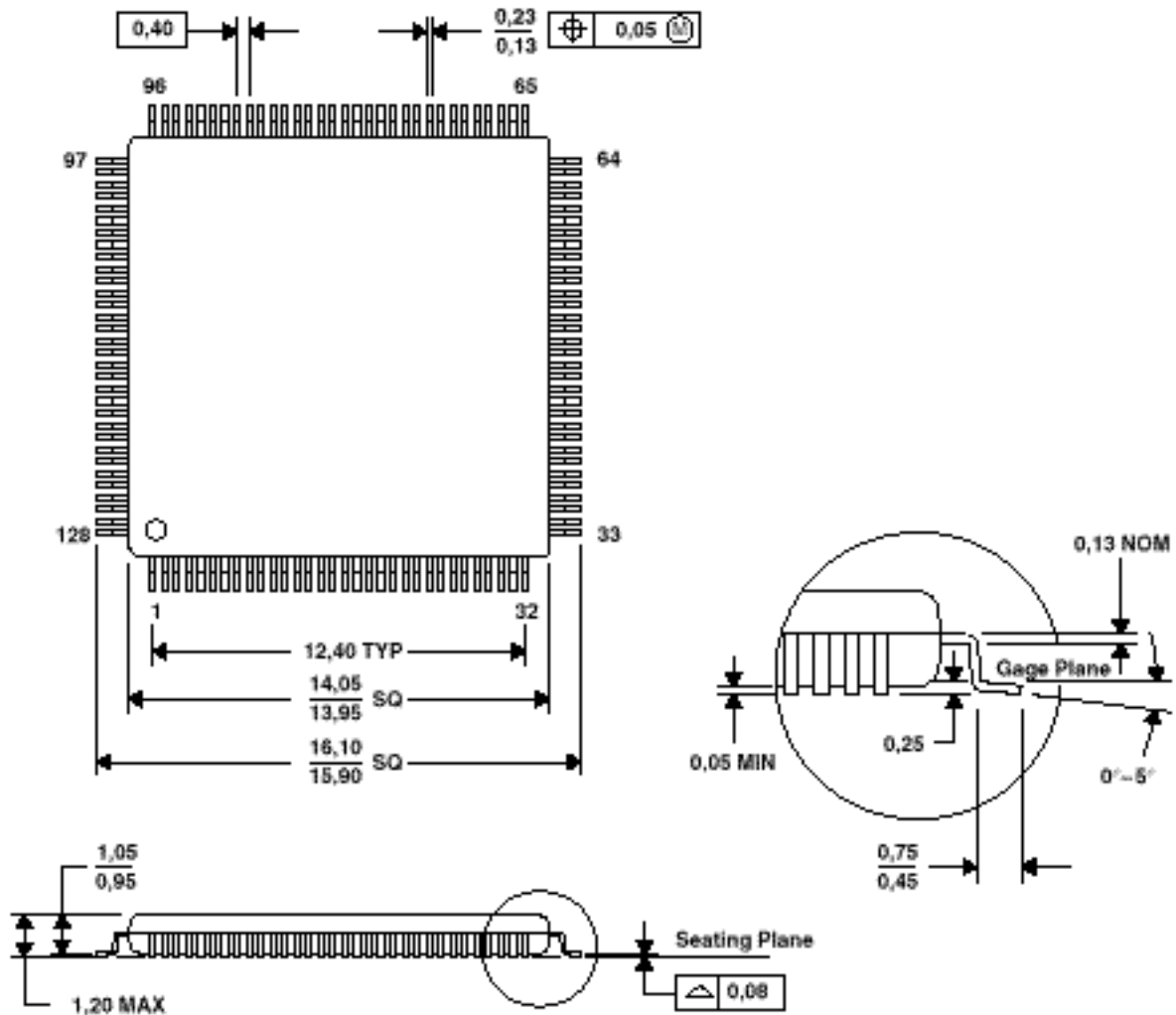
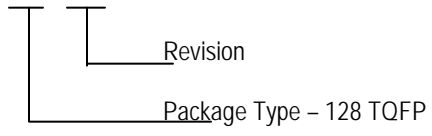

Figure 18: 128 TOFP package information

OXFW911-TQ - A



NOTES

CONTACT DETAILS

Oxford Semiconductor Ltd.

25 Milton Park
Abingdon
Oxfordshire
OX14 4SH
United Kingdom

<i>Telephone:</i>	+44 (0)1235 824900
<i>Fax:</i>	+44 (0)1235 821141
<i>Sales e-mail:</i>	sales@oxsemi.com
<i>Web site:</i>	http://www.oxsemi.com

DISCLAIMER

Oxford Semiconductor believes the information contained in this document to be accurate and reliable. However, it is subject to change without notice. No responsibility is assumed by Oxford Semiconductor for its use, nor for infringement of patents or other rights of third parties. No part of this publication may be reproduced, or transmitted in any form or by any means without the prior consent of Oxford Semiconductor Ltd. Oxford Semiconductor's terms and conditions of sale apply at all times.
