

## FEATURES

- High-Performance Static CMOS Technology
- TMS470R1x 16/32-Bit RISC Core (ARM7TDMI™)
  - 24-MHz System Clock (48-MHz Pipeline)
  - Independent 16/32-Bit Instruction Set
  - Open Architecture With Third-Party Support
  - Built-In Debug Module
- Integrated Memory
  - 288K-Byte Program Flash
    - Two Banks With 8 Contiguous Sectors
  - 16K-Byte Static RAM (SRAM)
  - Memory Security Module (MSM)
  - JTAG Security Module
- Operating Features
  - Low-Power Modes: STANDBY and HALT
  - Industrial Temperature Range
- 470+ System Module
  - 32-Bit Address Space Decoding
  - Bus Supervision for Memory/Peripherals
  - Digital Watchdog (DWD) Timer
  - Analog Watchdog (AWD) Timer
  - Enhanced Real-Time Interrupt (RTI)
  - Interrupt Expansion Module (IEM)
  - System Integrity and Failure Detection
  - ICE Breaker
- Direct Memory Access (DMA) Controller
  - 32 Control Packets and 16 Channels
- Zero-Pin Phase-Locked Loop (ZPLL)-Based Clock Module With Prescaler
  - Multiply-by-8 Internal ZPLL Option
  - ZPLL Bypass Mode
- Ten Communication Interfaces:
  - Two Serial Peripheral Interfaces (SPIs)
    - 255 Programmable Baud Rates
  - Two Serial Communication Interfaces (SCIs)
    - 2<sup>24</sup> Selectable Baud Rates
    - Asynchronous/Isosynchronous Modes
  - Class II Serial Interface B (C2S1b)
    - Normal 10.4 Kbps and 4X Mode 41.6 Kbps
  - Two Standard CAN Controllers (SCC)
    - 16-Mailbox Capacity
    - Fully Compliant With CAN Protocol, Version 2.0B
- Three Inter-Integrated Circuit (I2C) Modules
  - Multi-Master and Slave Interfaces
  - Up to 400 Kbps (Fast Mode)
  - 7- and 10-Bit Address Capability
- High-End Timer Lite (HET)
  - 12 Programmable I/O Channels:
    - 12 High-Resolution Pins
  - High-Resolution Share Feature (XOR)
  - High-End Timer RAM
    - 64-Instruction Capacity
- External Clock Prescale (ECP) Module
  - Programmable Low-Frequency External Clock (CLK)
- 12-Channel 10-Bit Multi-Buffered ADC (MibADC)
  - 64-Word FIFO Buffer
  - Single- or Continuous-Conversion Modes
  - 1.55 µs Minimum Sample/Conversion Time
  - Calibration Mode and Self-Test Features
- Flexible Interrupt Handling
- Expansion Bus Module (EBM) (PGE only)
  - Supports 8- and 16-Bit Expansion Bus Memory Interface Mappings
  - 42 I/O Expansion Bus Pins
- 50 Dedicated General-Purpose I/O (GIO) Pins and 43 Additional Peripheral I/Os (PGE)
- 14 Dedicated General-Purpose I/O (GIO) Pins and 43 Additional Peripheral I/Os (PZ)
- 16 External Interrupts
- On-Chip Scan-Base Emulation Logic, IEEE Standard 1149.1<sup>(1)</sup> (JTAG) Test-Access Port
- 144-Pin Plastic Low-Profile Quad Flatpack (PGE Suffix)
- 100-Pin Plastic Low-Profile Quad Flatpack (PZ Suffix)

<sup>(1)</sup> The test-access port is compatible with the IEEE Standard 1149.1-1990, IEEE Standard Test-Access Port and Boundary Scan Architecture specification. Boundary scan is not supported on this device.



Please be aware that an important notice concerning availability, standard warranty, and use in critical applications of Texas Instruments semiconductor products and disclaimers thereto appears at the end of this data sheet.

ARM7TDMI is a trademark of Advanced RISC Machines Limited (ARM).  
All trademarks are the property of their respective owners.

**TMS470R1A288**  
**16/32-Bit RISC Flash Microcontroller**

SPNS106–SEPTEMBER 2005

**TMS470R1A288 144-Pin PGE Package (Top View) (without Expansion Bus)**

Pin	Signal	Pin	Signal
108	ADIN[5]	72	HET[1]
107	ADIN[6]	71	HET[2]
106	ADIN[7]	70	GIOE[6]
105	ADIN[8]	69	VCCIO
104	ADIN[9]	68	VSSIO
103	ADIN[10]	67	GIOE[5]
102	ADIN[11]	66	HET[3]
101	ADEVT	65	HET[4]
100	GIOF[7]	64	GIOE[4]
99	GIOF[6]	63	HET[5]
98	GIOA[5]/INT[5]	62	SPI2SCS
97	PLLDIS	61	GIOE[3]
96	GIOF[5]	60	SPI2ENA
95	I2C2SCL	59	SPI2SIMO
94	I2C2SDA	58	GIOE[2]
93	GIOF[4]	57	SPI2SOMI
92	VCC	56	SPI2CLK
91	VSS	55	CAN2STX
90	GIOF[3]	54	CAN2SRX
89	GIOF[2]	53	VCC
88	I2C1SCL	52	VSS
87	I2C1SDA	51	SCI2CLK
86	VCCIO	50	SCI2RX
85	VSSIO	49	SCI2TX
84	CAN1STX	48	SCI1CLK
83	CAN1SRX	47	GIOE[1]
82	GIOF[1]	46	SCI1RX
81	CLKOUT	45	SCI1TX
80	GIOF[0]	44	GIOE[0]
79	GIOA[7]/INT[7]	43	GIOB[0]
78	GIOA[6]/INT[6]	42	GIOD[0]
77	GIOE[7]	41	GIOH[1]/INT[9]
76	TCK	40	GIOH[2]/INT[10]
75	TDO	39	GIOD[1]
74	TDI	38	GIOH[3]/INT[11]
73	HET[0]	37	GIOH[4]/INT[12]
109	ADREFHI		
110	ADREFLO		
111	VCCAD		
112	VSSAD		
113	ADIN[4]		
114	ADIN[3]		
115	ADIN[2]		
116	ADIN[1]		
117	ADIN[0]		
118	PORRST		
119	GIOC[4]		
120	GIOC[3]		
121	RST		
122	VSS		
123	VCC		
124	TEST		
125	GIOH[5]/INT[13]		
126	GIOC[2]		
127	GIOA[4]/INT[4]		
128	GIOC[1]		
129	VSS		
130	VCC		
131	VCCP		
132	FLTP2		
133	GIOA[3]/INT[3]		
134	GIOA[2]/INT[2]		
135	GIOC[0]		
136	GIOA[1]/INT[1]/ECLK		
137	VCCIO		
138	VSSIO		
139	GIOH[0]/INT[8]		
140	GIOG[7]		
141	GIOA[0]/INT[0]		
142	GIOG[6]		
143	GIOG[5]		
144	TRST		
1	SPI1SCS		
2	SPI1ENA		
3	GIOG[4]		
4	SPI1CLK		
5	SPI1SIMO		
6	GIOG[3]		
7	SPI1SOMI		
8	GIOG[2]		
9	HET[6]		
10	GIOG[1]		
11	HET[7]		
12	HET[8]		
13	VCC		
14	VSS		
15	HET[18]		
16	TMS2		
17	TMS		
18	HET[20]		
19	HET[22]		
20	GIOG[0]		
21	C2SILPN		
22	C2SIRX		
23	GIOD[5]		
24	C2SITX		
25	VCCIO		
26	VSSIO		
27	GIOD[4]		
28	I2C3SCL		
29	I2C3SDA		
30	GIOD[3]		
31	VCC		
32	OSCOUT		
33	OSCIN		
34	VSS		
35	GIOD[2]		
36	AWD		



# TMS470R1A288 16/32-Bit RISC Flash Microcontroller

SPNS106—SEPTEMBER 2005

TMS470R1A288 100-Pin PZ Package (Top View)

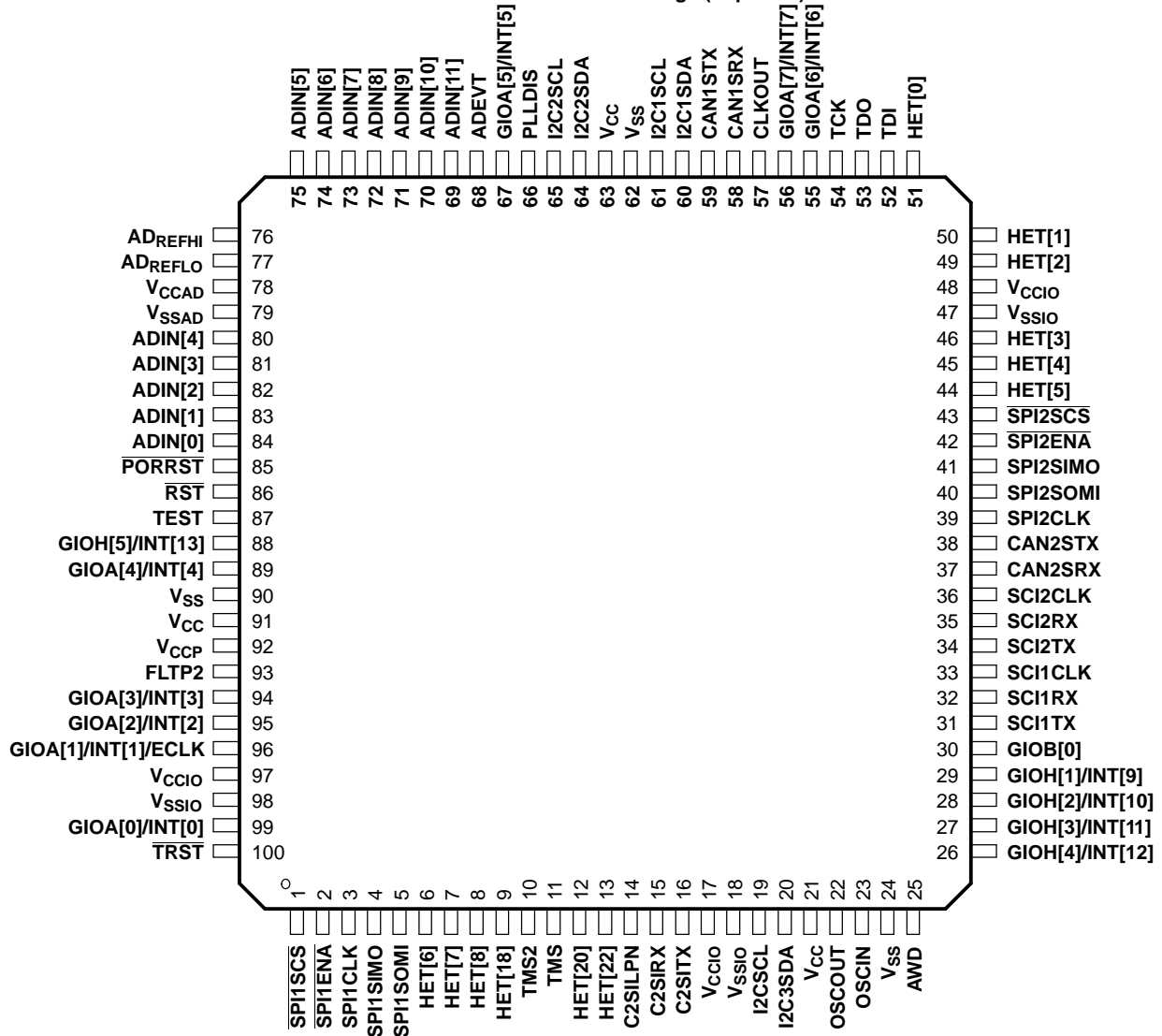

## DESCRIPTION

The TMS470R1A288<sup>(1)</sup> devices are members of the Texas Instruments TMS470R1x family of general-purpose 16/32-bit reduced instruction set computer (RISC) microcontrollers. The A288 microcontroller offers high performance utilizing the high-speed ARM7TDMI 16/32-bit RISC central processing unit (CPU), resulting in a high instruction throughput while maintaining greater code efficiency. The ARM7TDMI 16/32-bit RISC CPU views memory as a linear collection of bytes numbered upwards from zero. The A288 utilizes the big-endian format where the most significant byte of a word is stored at the lowest-numbered byte and the least significant byte at the highest numbered byte.

High-end embedded control applications demand more performance from their controllers while maintaining low costs. The A288 RISC core architecture offers solutions to these performance and cost demands while maintaining low power consumption.

The A288 devices contain the following:

- ARM7TDMI 16/32-Bit RISC CPU
- TMS470R1x system module (SYS) with 470+ enhancements
- 288K-byte flash
- 16K-byte SRAM
- Zero-pin phase-locked loop (ZPLL) clock module
- Digital watchdog (DWD) timer
- Analog watchdog (AWD) timer
- Enhanced real-time interrupt (RTI) module
- Interrupt expansion module (IEM)
- Memory security module (MSM)
- JTAG security module (JSM)
- Two serial peripheral interface (SPI) modules
- Two serial communications interface (SCI) modules
- Two standard CAN controllers (SCC)
- Three inter-integrated circuit (I2C) modules
- Class II serial interface B (C2SIb) module
- 10-bit multi-buffered analog-to-digital converter (MibADC), with 12 input channels
- High-end timer lite (HET) controlling 12 I/Os
- External clock prescale (ECP)
- Expansion bus module (EBM)
- Up to 93 I/O pins (PGE only), up to 57 I/O (PZ only)

The functions performed by the 470+ system module (SYS) include:

- Address decoding
- Memory protection
- Memory and peripherals bus supervision
- Reset and abort exception management
- Prioritization for all internal interrupt sources
- Device clock control
- Parallel signature analysis (PSA)

The enhanced real-time interrupt (RTI) module on the A288 has the option to be driven by the oscillator clock. The digital watchdog (DWD) is a 25-bit resettable decrementing counter that provides a system reset when the watchdog counter expires. This data sheet includes device-specific information such as memory and peripheral select assignment, interrupt priority, and a device memory map. For a more detailed functional description of the SYS module, see the *TMS470R1x System Module Reference Guide* (literature number SPNU189).

The A288 memory includes general-purpose SRAM supporting single-cycle read/write accesses in byte, half-word, and word modes.

(1) Throughout the remainder of this document, the TMS470R1A288 will be referred to as either the full device name or as A288.

The flash memory on this device is a nonvolatile, electrically erasable and programmable memory implemented with a 32-bit-wide data bus interface. When in pipeline mode, the flash operates with a system clock frequency of up to 48 MHz. The flash operates with a system clock frequency of up to 24 MHz. For more detailed information on the flash, see the *Flash* section of this data sheet and the *TMS470R1x F05 Flash Reference Guide* (literature number SPNU213).

The memory security module (MSM) and JTAG security module (JSM) prevent unauthorized access and visibility to on-chip memory, thereby preventing reverse engineering or manipulation of proprietary code. For more information, see the *TMS470R1x Memory Security Module Reference Guide* (literature number SPNU246) and the *TMS470R1x JTAG Security Module Reference Guide* (literature number SPNU245).

The A288 device has ten communication interfaces: two SPIs, two SCIs, two SCCs, a C2SI, and three I2Cs. The SPI provides a convenient method of serial interaction for high-speed communications between similar shift-register type devices. The SCI is a full-duplex, serial I/O interface intended for asynchronous communication between the CPU and other peripherals using the standard non-return-to-zero (NRZ) format. The SCC uses a serial, multimaster communication protocol that efficiently supports distributed real-time control with robust communication rates of up to 1 megabit per second (Mbps). The SCC is ideal for applications operating in noisy and harsh environments (e.g., industrial fields) that require reliable serial communication or multiplexed wiring. The C2SIb allows the A288 to transmit and receive messages on a class II network following an SAE J1850<sup>(2)</sup> standard. The I2C module is a multi-master communication module providing an interface between the A288 microcontroller and an I2C-compatible device via the I2C serial bus. The I2C supports both 100 Kbps and 400 Kbps speeds. For more detailed functional information on the SPI, SCI, and CAN peripherals, see the specific reference guides (literature numbers SPNU195, SPNU196, and SPNU197). For more detailed functional information on the I2C, see the *TMS470R1x Inter-Integrated Circuit (I2C) Reference Guide* (literature number SPNU223). For more detailed functional information on the C2SI, see the *TMS470R1x Class II Serial Interface B (C2SIb) Reference Guide* (literature number SPNU214).

The HET is an advanced intelligent timer that provides sophisticated timing functions for real-time applications. The timer is software-controlled, using a reduced instruction set, with a specialized timer micromachine and an attached I/O port. The HET can be used for compare, capture, or general-purpose I/O. It is especially well suited for applications requiring multiple sensor information and drive actuators with complex and accurate time pulses. The HET used in this device is the high-end timer lite. It has fewer I/Os than the usual 32 in a standard HET. For more detailed functional information on the HET, see the *TMS470R1x High-End Timer (HET) Reference Guide* (literature number SPNU199).

The A288HET peripheral contains the XOR-share feature. This feature allows two adjacent HET high-resolution channels to be XORed together, making it possible to output smaller pulses than a standard HET. For more detailed information on the HET XOR-share feature, see the *TMS470R1x High-End Timer (HET) Reference Guide* (literature number SPNU199).

The A288 device has one 10-bit-resolution, sample-and-hold MibADC. Each of the MibADC channels can be converted individually or can be grouped by software for sequential conversion sequences. There are three separate groupings, two of which can be triggered by an external event. Each sequence can be converted once when triggered or configured for continuous conversion mode. For more detailed functional information on the MibADC, see the *TMS470R1x Multi-Buffered Analog-to-Digital Converter (MibADC) Reference Guide* (literature number SPNU206).

The zero-pin phase-locked loop (ZPLL) clock module contains a phase-locked loop, a clock-monitor circuit, a clock-enable circuit, and a prescaler (with prescale values of 1–8). The function of the ZPLL is to multiply the external frequency reference to a higher frequency for internal use. The ZPLL provides ACLK to the system (SYS) module. The SYS module subsequently provides system clock (SYSCLK), real-time interrupt clock (RTICLK), CPU clock (MCLK), and peripheral interface clock (ICLK) to all other A288 device modules. For more detailed functional information on the ZPLL, see the *TMS470R1x Zero-Pin Phase-Locked Loop (ZPLL) Clock Module Reference Guide* (literature number SPNU212).

**NOTE:**

ACLK should not be confused with the MibADC internal clock, ADCLK. ACLK is the continuous system clock from an external resonator/crystal reference.

(2) SAE Standard J1850 Class B Data Communication Network Interface

The expansion bus module (EBM) is a standalone module that supports the multiplexing of the GIO functions and the expansion bus interface. For more information on the EBM, see the *TMS470R1x Expansion Bus Module (EBM) Reference Guide* (literature number SPNU222).

The A288 device also has an external clock prescaler (ECP) module that when enabled, outputs a continuous external clock (ECLK) on a specified GIO pin. The ECLK frequency is a user-programmable ratio of the peripheral interface clock (ICLK) frequency. For more detailed functional information on the ECP, see the *TMS470R1x External Clock Prescaler (ECP) Reference Guide* (literature number SPNU202).

**Device Characteristics**

The A288 device is a derivative of the F05 system emulation device SE470R1VB8AD. [Table 1](#) identifies all the characteristics of the A288 device except the SYSTEM and CPU, which are generic.

**Table 1. Device Characteristics**

CHARACTERISTICS	DEVICE DESCRIPTION TMS470R1A288	COMMENTS
<b>MEMORY</b>		
For the number of memory selects on this device, see <a href="#">Table 3</a> , <i>TMS470R1A288 Memory Selection Assignment</i> .		
INTERNAL MEMORY	Pipeline/Non-Pipeline 288K-Byte Flash 16K-Byte SRAM Memory Security Module (MSM) JTAG Security Module (JSM)	Flash is pipeline-capable. The A288 RAM is implemented in one 16K-byte array selected by two memory-select signals (see <a href="#">Table 3</a> , <i>TMS470R1A288 Memory Selection Assignment</i> ).
<b>PERIPHERALS</b>		
For the device-specific interrupt priority configurations, see <a href="#">Table 6</a> , <i>Interrupt Priority (IEM and CIM)</i> . For the 1K-byte peripheral address ranges and their peripheral selects, see <a href="#">Table 4</a> , <i>A288 Peripherals, System Module, and Flash Base Addresses</i> .		
CLOCK	ZPLL	Zero-pin phase-locked loop has no external loop filter pins.
EXPANSION BUS	EBM	Expansion bus module with 42 pins. Supports 8- and 16-bit memories. See <a href="#">Table 7</a> for details.
GENERAL-PURPOSE I/Os	50 I/O (PGE Suffix) 14 I/O (PZ Suffix)	In the PGE package, Port A has 8 external pins, Port B has only 1 external pin, Port C has 5 external pins, Port D has 6 external pins, Ports E, F, and G each have 8 external pins, and Port H has 6 external pins. In the PZ package, Port A has 8 external pins, Port B has only 1 external pin, and Port H has 5 external pins.
ECP	YES	
SCI	2 (3-pin)	
CAN (HECC and/or SCC)	2 SCC	Two standard CAN controllers
SPI (5-pin, 4-pin or 3-pin)	2 (5-pin)	
C2S1b	1	
I2C	3	
HET with XOR SHARE	12 I/O	The high-resolution (HR) SHARE feature allows even-numbered HR pins to share the next higher odd HR pin structures. This HR sharing is independent of whether or not the odd pin is available externally. If an odd pin is available externally and shared, then the odd pin can only be used as a general-purpose I/O. For more information on HR SHARE, see the <i>TMS470R1x High-End Timer (HET) Reference Guide</i> (literature number SPNU199).
HET RAM	64-Instruction Capacity	
MibADC	10-bit, 12-channel 64-word FIFO	Both the logic and registers for a full 16-channel MibADC are present.
CORE VOLTAGE	1.8 V	
I/O VOLTAGE	3.3 V	
PINS	144 100	
PACKAGES	PGE PZ	



**Functional Block Diagram**

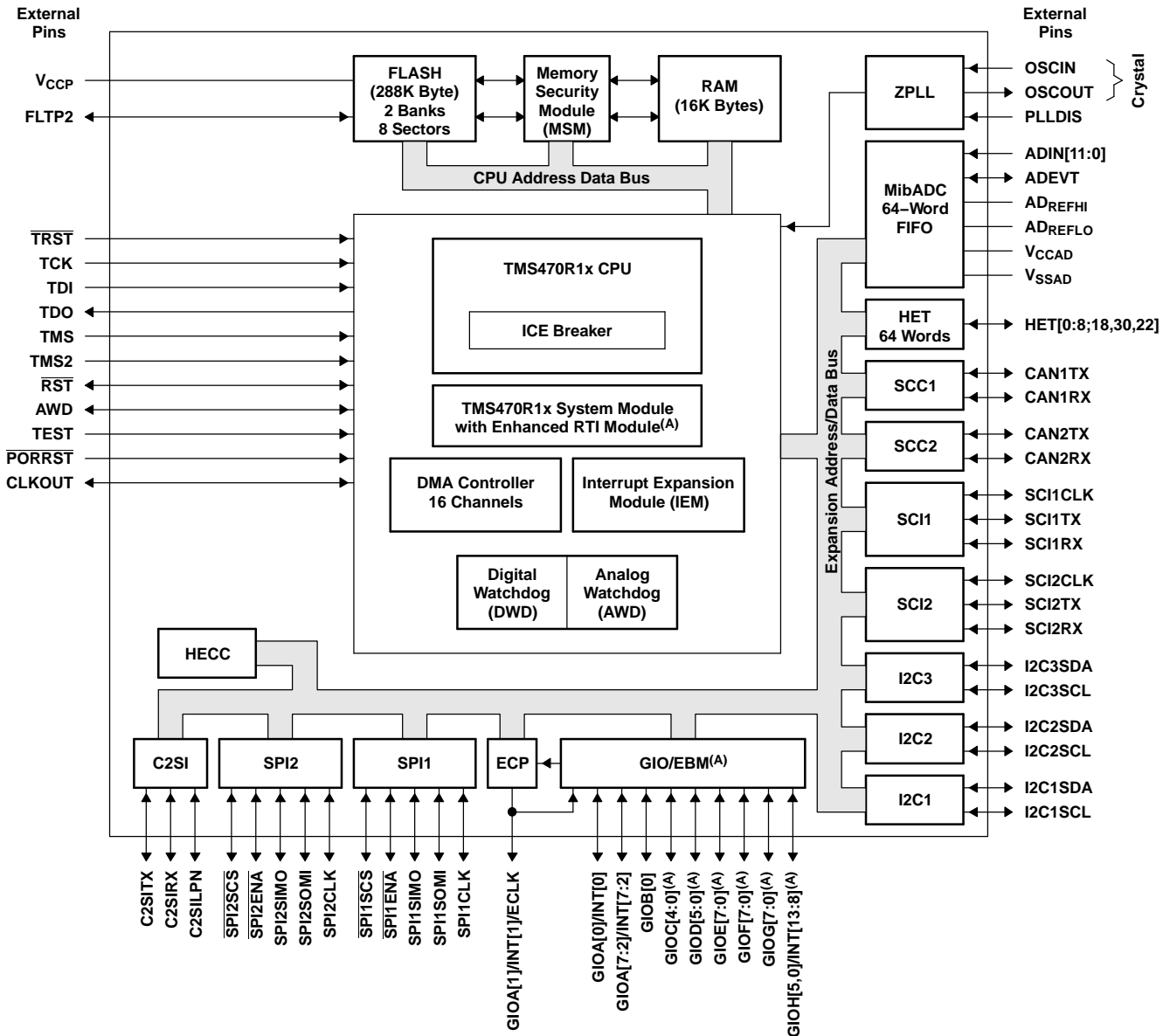

- A. The enhanced RTI module is the system module with two extra bits to disable the ZPLL while in STANDBY mode.
- B. GIOC[4:0], GIOD[5:0], GIOE[5:0], GIOF[7:0], and GIOH[0], which are muxed with EBM, are not available on the PZ package. See [Table 7](#) for EBM-to-GIO mapping.

**Table 2. Terminal Functions**

TERMINAL			INPUT VOLTAGE <sup>(1)(2)</sup>	OUTPUT CURRENT <sup>(3)</sup>	INTERNAL PULLUP/PULLDOWN	DESCRIPTION
NAME	PZ	PGE				
<b>HIGH-END TIMER (HET)</b>						
HET[0]	51	73	3.3-V	2 mA -z		<p>Timer input capture or output compare. The HET[8:0,18,20,22] applicable pins can be programmed as general-purpose input/output (GIO) pins. All are high-resolution pins.</p> <p>The high-resolution (HR) SHARE feature allows even HR pins to share the next higher odd HR pin structures. This HR sharing is independent of whether or not the odd pin is available externally. If an odd pin is available externally and shared, then the odd pin can only be used as a general-purpose I/O. For more information on HR SHARE, see the <i>TMS470R1x High-End Timer (HET) Reference Guide</i> (literature number SPNU199).</p>
HET[1]	50	72				
HET[2]	49	71				
HET[3]	46	66				
HET[4]	45	65				
HET[5]	44	63				
HET[6]	6	9				
HET[7]	7	11				
HET[8]	8	12				
HET[18]	9	15				
HET[20]	12	18				
HET[22]	13	19				
<b>STANDARD CAN CONTROLLER (SCC)</b>						
CAN1SRX	58	83	5 V tolerant	4 mA		SCC1 receive pin or GIO pin
CAN1STX	59	84	3.3-V	2 mA -z		SCC1 transmit pin or GIO pin
CAN2SRX	37	54	5 V tolerant	4 mA		SCC2 receive pin or GIO pin
CAN2STX	38	55	3.3-V	2 mA -z		SCC 2 transmit pin or GIO pin
<b>CLASS II SERIAL INTERFACE (C2SIB)</b>						
C2SILPN	14	21	3.3-V	2 mA -z		C2S1b module loopback enable pin or GIO pin
C2SIRX	15	22	5 V tolerant	4 mA		C2S1b module receive data input pin or GIO pin
C2SITX	16	24	3.3-V	2 mA -z		C2S1b module transmit data output pin or GIO pin
<b>GENERAL-PURPOSE I/O (GIO)</b>						
GIOA[0]/INT[0]	99	141	5 V tolerant	4 mA		<p>General-purpose input/output pins. GIOA[7:0]/INT[7:0] are interrupt-capable pins. GIOA[1]/INT[1]/ECLK pin is multiplexed with the external clock-out function of the external clock prescale (ECP) module.</p>
GIOA[1]/INT[1]/ECLK	96	136				
GIOA[2]/INT[2]	95	134				
GIOA[3]/INT[3]	94	133				
GIOA[4]/INT[4]	89	127				
GIOA[5]/INT[5]	67	98				
GIOA[6]/INT[6]	55	78				
GIOA[7]/INT[7]	56	79				
GIOB[0]/DMAREQ[0]	30	43	3.3-V	2 mA -z	IPD (20 µA)	<p>GIOB[0], GIOC[4:0], GIOD[5:0], GIOE[7:0], GIOF[7:0], GIOG[7:0], and GIOH[5:0] are multiplexed with the expansion bus module. See <a href="#">Table 7</a>.</p>
GIOC[0]/EBOE	-	135				
GIOC[1]/EBWR[0]	-	128				
GIOC[2]/EBWR[1]	-	126				
GIOC[3]/EBCS[5]	-	120				
GIOC[4]/EBCS[6]	-	119				

- (1) PWR = power, GND = ground, REF = reference voltage, NC = no connect
- (2) All I/O pins, except  $\overline{RST}$ , are configured as inputs while  $\overline{PORRST}$  is low and immediately after  $\overline{PORRST}$  goes high.
- (3) IPD = internal pulldown, IPU = internal pullup (all internal pullups and pulldowns are active on input pins, independent of the  $\overline{PORRST}$  state.)

**Table 2. Terminal Functions (continued)**

TERMINAL			INPUT VOLTAGE <sup>(1)(2)</sup>	OUTPUT CURRENT <sup>(3)</sup>	INTERNAL PULLUP/ PULLDOWN	DESCRIPTION
NAME	PZ	PGE				
<b>GENERAL-PURPOSE I/O (GIO) (CONTINUED)</b>						
GIOD[0]/EBADDR[0]	-	42	3.3-V	2 mA -z	IPD (20 µA)	GIOB[0], GIOC[4:0], GIOD[5:0], GIOE[7:0:], GIOF[7:0], GIOG[7:0], AND GIOH[5:0] are multiplexed with the expansion bus module. See <a href="#">Table 7</a> .
GIOD[1]/EBADDR[1]	-	39				
GIOD[2]/EBADDR[2]	-	35				
GIOD[3]/EBADDR[3]	-	30				
GIOD[4]/EBADDR[4]	-	27				
GIOD[5]/EBADDR[5]	-	23				
GIOE[0]/EBDATA[0]	-	44				
GIOE[1]/EBDATA[1]	-	47				
GIOE[2]/EBDATA[2]	-	58				
GIOE[3]/EBDATA[3]	-	61				
GIOE[4]/EBDATA[4]	-	64				
GIOE[5]/EBDATA[5]	-	67				
GIOE[6]/EBDATA[6]	-	70				
GIOE[7]/EBDATA[7]	-	77				
GIOF[0]/EBADDR[6]/ EBDATA[8]	-	80				
GIOF[1]/EBADDR[7]/ EBDATA[9]	-	82				
GIOF[2]/EBADDR[8]/ EBDATA[10]	-	89				
GIOF[3]/EBADDR[9]/ EBDATA[11]	-	90				
GIOF[4]/EBADDR[10]/ EBDATA[12]	-	93				
GIOF[5]/EBADDR[11]/ EBDATA[13]	-	96				
GIOF[6]/EBADDR[12]/ EBDATA[14]	-	99				
GIOF[7]/EBADDR[13]/ EBDATA[15]	-	100				
GIOG[0]/EBADDR[14] /EBADDR[6]	-	20				
GIOG[1]/EBADDR[15] /EBADDR[7]	-	10				
GIOG[2]/EBADDR[16] /EBADDR[8]	-	8				
GIOG[3]/EBADDR[17] /EBADDR[9]	-	6				

**Table 2. Terminal Functions (continued)**

TERMINAL			INPUT VOLTAGE <sup>(1)(2)</sup>	OUTPUT CURRENT <sup>(3)</sup>	INTERNAL PULLUP/PULLDOWN	DESCRIPTION
NAME	PZ	PGE				
<b>GENERAL-PURPOSE I/O (GIO) (CONTINUED)</b>						
GIOG[4]/EBADDR[18]/EBADDR[10]	-	3	3.3-V	2 mA -z	IPD (20 µA)	GIOB[0], GIOC[4:0], GIOD[5:0], GIOE[7:0], GIOF[7:0], GIOG[7:0], AND GIOH[5:0] are multiplexed with the expansion bus module. See <a href="#">Table 7</a> . GIOH[5:0]/INT[13:8] are interrupt-capable pins.
GIOG[5]/EBADDR[19]/EBADDR[11]	-	143				
GIOG[6]/EBADDR[20]/EBADDR[12]	-	142				
GIOG[7]/EBADDR[21]/EBADDR[13]	-	140				
GIOH[0]/EBADDR[22]/EBADDR[14]/INT[8]	-	139		2 mA		
GIOH[1]/EBADDR[23]/EBADDR[15]/INT[9]	29	41				
GIOH[2]/EBADDR[24]/EBADDR[16]/INT[10]	28	40				
GIOH[3]/EBADDR[25]/EBADDR[17]/INT[11]	27	38				
GIOH[4]/EBADDR[26]/EBADDR[18]/INT[12]	26	37				
GIOH[5]/EBHOLD/INT[13]	88	125				
<b>MULTI-BUFFERED ANALOG-TO-DIGITAL CONVERTER (MibADC)</b>						
ADEVT	68	101	3.3-V	2 mA -z		MibADC event input. Can be programmed as a GIO pin.
ADIN[0]	84	117	3.3-V			MibADC analog input pins
ADIN[1]	83	116				
ADIN[2]	82	115				
ADIN[3]	81	114				
ADIN[4]	80	113				
ADIN[5]	75	108				
ADIN[6]	74	107				
ADIN[7]	73	106				
ADIN[8]	72	105				
ADIN[9]	71	104				
ADIN[10]	70	103				
ADIN[11]	69	102				
AD <sub>REFHI</sub>	76	109	3.3-V REF			MibADC module high-voltage reference input
AD <sub>REFLO</sub>	77	110	GND REF			MibADC module low-voltage reference input
V <sub>CCAD</sub>	78	111	3.3-V PWR			MibADC analog supply voltage
V <sub>SSAD</sub>	79	112	GND			MibADC analog ground reference

**Table 2. Terminal Functions (continued)**

TERMINAL			INPUT VOLTAGE <sup>(1)(2)</sup>	OUTPUT CURRENT <sup>(3)</sup>	INTERNAL PULLUP/ PULLDOWN	DESCRIPTION
NAME	PZ	PGE				
<b>SERIAL PERIPHERAL INTERFACE 1 (SPI1)</b>						
SPI1CLK	3	4	5 V tolerant	4 mA		SPI1 clock. SPI1CLK can be programmed as a GIO pin.
SPI1EN $\bar{A}$	2	2				SPI1 chip enable. Can be programmed as a GIO pin.
SPI1SCS	1	1				SPI1 slave chip select. Can be programmed as a GIO pin.
SPI1SIMO	4	5				SPI1 data stream. Slave in/master out. Can be programmed as a GIO pin.
SPI1SOMI	5	7				SPI1 data stream. Slave out/master in. Can be programmed as a GIO pin.
<b>SERIAL PERIPHERAL INTERFACE 2 (SPI2)</b>						
SPI2CLK	39	56	5 V tolerant	4 mA		SPI2 clock. Can be programmed as a GIO pin.
SPI2EN $\bar{A}$	42	60				SPI2 chip enable. Can be programmed as a GIO pin.
SPI2SCS	43	62				SPI2 slave chip select. Can be programmed as a GIO pin.
SPI2SIMO	41	59				SPI2 data stream. Slave in/master out. Can be programmed as a GIO pin.
SPI2SOMI	40	57				SPI2 data stream. Slave out/master in. Can be programmed as a GIO pin.
<b>INTER-INTEGRATED CIRCUIT (I2C)</b>						
I2C1SDA	60	87	5 V tolerant	4 mA		I2C1 serial data pin or GIO pin
I2C1SCL	61	88				I2C1 serial clock pin or GIO pin
I2C2SDA	64	94				I2C2 serial data pin or GIO pin
I2C2SCL	65	95				I2C2 serial clock pin or GIO pin
I2C3SDA	20	29				I2C3 serial data pin or GIO pin
I2C3SCL	19	28				I2C3 serial clock pin or GIO pin
<b>ZERO-PIN PHASE-LOCKED LOOP (ZPLL)</b>						
OSCIN	23	33	1.8-V			Crystal connection pin or external clock input
OSCOU $\bar{T}$	22	32		2 mA		External crystal connection pin
PLLDIS	66	97	3.3-V		IPD (20 $\mu$ A)	Enable/disable the ZPLL. The ZPLL can be bypassed and the oscillator becomes the system clock. If not in bypass mode, TI recommends that this pin be connected to ground or pulled down to ground by an external resistor.
<b>SERIAL COMMUNICATIONS INTERFACE 1 (SCI1)</b>						
SCI1CLK	33	48	3.3-V	2 mA -z		SCI1 clock. SCI1CLK can be programmed as a GIO pin.
SCI1RX	32	46	5 V tolerant	4 mA		SCI1 data receive. SCI1RX can be programmed as a GIO pin.
SCI1TX	31	45	3.3-V	2 mA -z		SCI1 data transmit. SCI1TX can be programmed as a GIO pin.
<b>SERIAL COMMUNICATIONS INTERFACE 2 (SCI2)</b>						
SCI2CLK	36	51	3.3-V	2 mA -z		SCI2 clock. SCI2CLK can be programmed as a GIO pin.
SCI2RX	35	50	5 V tolerant	4 mA		SCI2 data receive. SCI2RX can be programmed as a GIO pin.
SCI2TX	34	49	3.3-V	2 mA -z		SCI2 data transmit. SCI2TX can be programmed as a GIO pin.

**Table 2. Terminal Functions (continued)**

TERMINAL			INPUT VOLTAGE <sup>(1)(2)</sup>	OUTPUT CURRENT <sup>(3)</sup>	INTERNAL PULLUP/PULLDOWN	DESCRIPTION	
NAME	PZ	PGE					
<b>SYSTEM MODULE (SYS)</b>							
CLKOUT	57	81	3.3-V	8 mA		Bidirectional pin. CLKOUT can be programmed as a GIO pin or the output of SYSCLK, ICLK, or MCLK.	
$\overline{\text{PORRST}}$	85	118	3.3-V		IPD (20 $\mu$ A)	Input master chip power-up reset. External $V_{CC}$ monitor circuitry must assert a power-on reset.	
$\overline{\text{RST}}$	86	121	3.3-V	4 mA	IPU (20 $\mu$ A)	Bidirectional reset. The internal circuitry can assert a reset, and an external system reset can assert a device reset. On this pin, the output buffer is implemented as an open drain (drives low only). To ensure an external reset is not arbitrarily generated, TI recommends that an external pullup resistor be connected to this pin.	
<b>WATCHDOG/REAL-TIME INTERRUPT (WD/RTI)</b>							
AWD	25	36	3.3-V	8 mA		Analog watchdog reset. The AWD pin provides a system reset if the WD KEY is not written in time by the system, providing an external RC network circuit is connected. If the user is not using AWD, TI recommends that this pin be connected to ground or pulled down to ground by an external resistor.  For more details on the external RC network circuit, see the <i>TMS470R1x System Module Reference Guide</i> (literature number SPNU189).	
<b>TEST/DEBUG (T/D)</b>							
TCK	54	76	3.3-V		IPD (20 $\mu$ A)	Test clock. TCK controls the test hardware (JTAG).	
TDI	52	74				8 mA	Test data in. TDI inputs serial data to the test instruction register, test data register, and programmable test address (JTAG).
TDO	53	75				8 mA	Test data out. TDO outputs serial data from the test instruction register, test data register, identification register, and programmable test address (JTAG).
TEST	87	124				Test enable. Reserved for internal use only. TI recommends that this pin be connected to ground or pulled down to ground by an external resistor.	
TMS	11	17				8 mA	Serial input for controlling the state of the CPU test access port (TAP) controller (JTAG).
TMS2	10	16				8 mA	Serial input for controlling the second TAP. TI recommends that this pin be connected to VCCIO or pulled up to VCCIO by an external resistor.
$\overline{\text{TRST}}$	100	144					Test hardware reset to TAP1 and TAP2. IEEE Standard 1149-1 (JTAG) Boundary-Scan Logic. TI recommends that this pin be pulled down to ground by an external resistor.

**Table 2. Terminal Functions (continued)**

TERMINAL			INPUT VOLTAGE <sup>(1)(2)</sup>	OUTPUT CURRENT <sup>(3)</sup>	INTERNAL PULLUP/ PULLDOWN	DESCRIPTION
NAME	PZ	PGE				
<b>FLASH</b>						
FLTP2	93	132	NC	NC		Flash test pad 2. <b>For proper operation, this pin must not be connected [no connect (NC)].</b>
V <sub>CCP</sub>	92	131	3.3-V PWR			Flash external pump voltage (3.3 V)
<b>SUPPLY VOLTAGE CORE (1.8 V)</b>						
V <sub>CC</sub>	21	13	1.8-V	PWR		Core logic supply voltage
	63	31				
	91	53				
	-	92				
	-	123				
	-	130				
<b>SUPPLY VOLTAGE DIGITAL I/O (3.3 V)</b>						
V <sub>CCIO</sub>	17	25	3.3-V	PWR		Digital I/O supply voltage
	48	69				
	-	86				
	97	137				
<b>SUPPLY GROUND CORE</b>						
V <sub>SS</sub>	90	14	GND			Core supply ground reference
	-	34				
	-	52				
	-	91				
	62	122				
	24	129				
<b>SUPPLY GROUND DIGITAL I/O</b>						
V <sub>SSIO</sub>	18	26	GND			Digital I/O supply ground reference
	47	68				
	-	85				
	98	138				

TMS470R1A288 DEVICE-SPECIFIC INFORMATION

Memory

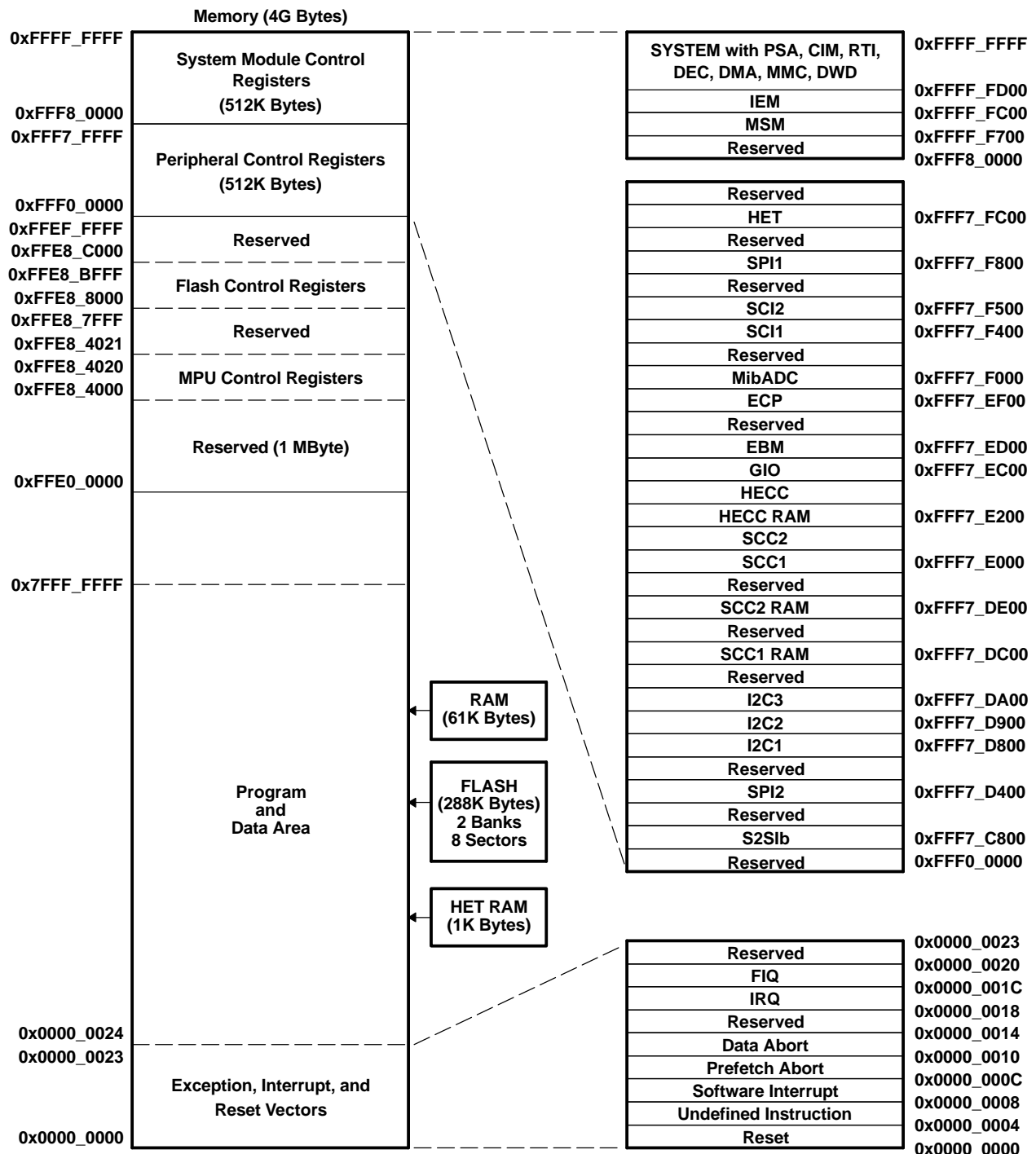

- A. Memory addresses are configurable by the system (SYS) module within the range of 0x0000\_0000 to 0xFFE0\_0000.
- B. The CPU registers are not a part of the memory map.

Figure 1. TMS470R1A288 Memory Map



## Memory Selects

Memory selects allow the user to address memory arrays (i.e., flash, RAM, and HET RAM) at user-defined addresses. Each memory select has its own set (low and high) of memory base address registers (MFBAHRx and MFBALRx) that, together, define the array's starting (base) address, block size, and protection.

The base address of each memory select is configurable to any memory address boundary that is a multiple of the decoded block size. For more information on how to control and configure these memory select registers, see the bus structure and memory sections of the *TMS470R1x System Module Reference Guide* (literature number SPNU189).

For the memory selection assignments and the memory selected, see [Table 3](#).

**Table 3. TMS470R1A288 Memory Selection Assignment**

MEMORY SELECT	MEMORY SELECTED (ALL INTERNAL)	MEMORY SIZE <sup>(1)</sup>	MPU	MSM	MEMORY BASE ADDRESS REGISTER	STATIC MEM CTL REGISTER
0 (fine)	FLASH/ROM	288K	NO	YES	MFBAHR0 and MFBALR0	
1 (fine)	FLASH/ROM		NO	YES	MFBAHR1 and MFBALR1	
2 (fine)	RAM	16K <sup>(2)</sup>	YES	YES	MFBAHR2 and MFBALR2	
3 (fine)	RAM		YES	YES	MFBAHR3 and MFBALR3	
4 (fine)	HET RAM	1K	NO	NO	MFBAHR4 and MFBALR4	SMCR1
5 (coarse)	$\overline{CS}[5]/\text{GIOC}[3]$	128 MB (x8) 1MB (x16)	NO	NO	MCBAHR2 and MCBALR2	SMCR5
6 (coarse)	$\overline{CS}[6]/\text{GIOC}[4]$	128 MB (x8) 1MB (x16)	NO	NO	MCBAHR3 and MCBALR3	SMCR6

(1) x8 refers to size of memory in 8-bits; x16 refers to size of memory in 16-bits.

(2) The starting addresses for both RAM memory-select signals cannot be offset from each other by a multiple of the user-defined block size in the memory-base address register.

## Memory Security Module

The A288 device also includes a memory security module (MSM) to provide additional security and flexibility to the memory contents' protection. The password for unlocking the MSM is located in the four words just before the flash protection keys (see the *Flash Protection Keys* section below).

## JTAG Security Module (JSM)

The A288 device includes a JTAG security module to provide maximum security to the memory contents. The visible unlock code can be chosen to be in the OTP sector or in the first bank of the user-programmable memory. For the A288, the visible unlock code is in the OTP sector.

## RAM

The A288 device contains 16K-bytes of internal static RAM configurable by the SYS module to be addressed within the range of 0x0000\_0000 to 0xFFE0\_0000. This A288 RAM is implemented in one 16K-byte array selected by two memory-select signals.

### NOTE:

This A288 configuration imposes an additional constraint on the memory map for RAM; the starting addresses for both RAM memory selects cannot be offset from each other by the multiples of the size of the physical RAM (i.e., 16K for the A288 device). The A288 RAM is addressed through memory selects 2 and 3.

The RAM can be protected by the memory protection unit (MPU) portion of the SYS module, allowing the user finer blocks of memory protection than is allowed by the memory selects. The MPU is ideal for protecting an operating system while allowing access to the current task. For more detailed information on the MPU portion of the SYS module and memory protection, see the memory section of the *TMS470R1x System Module Reference Guide* (literature number SPNU189).

**F05 Flash**

The F05 flash memory is a nonvolatile electrically erasable and programmable memory implemented with a 32-bit-wide data bus interface. The F05 flash has an external state machine for programming and erase functions. See the *Flash Read* and *Flash Program and Erase* sections below.

**Flash Protection Keys**

The A288 device provides flash protection keys. These four 32-bit protection keys prevent program/erase/compaction operations from occurring until after the four protection keys have been matched by the CPU loading the correct user keys into the FMPKEY control register. The protection keys on the A288 are located in the last 4 words of the first 8K sector. For more detailed information on the flash protection keys and the FMPKEY control register, see the "Optional Quadruple Protection Keys" and "Programming the Protection Keys" portions of the *TMS470R1x F05 Flash Reference Guide* (literature number SPNU213).

**Flash Read**

The A288 flash memory is configurable by the SYS module to be addressed within the range of 0x0000\_0000 to 0xFFE0\_0000. The flash is addressed through memory selects 0 and 1.

**NOTE:**

The flash external pump voltage ( $V_{CCP}$ ) is required for all operations (program, erase, and read).

**Flash Pipeline Mode**

When in pipeline mode, the flash operates with a system clock frequency of up to 48 MHz. In normal mode, the flash operates with a system clock frequency of up to 24 MHz. Flash in pipeline mode is capable of accessing 64-bit words and provides two 32-bit pipelined words to the CPU. Also, in pipeline mode the flash can be read with no wait states when memory addresses are contiguous (after the initial 1- or 2-wait-state reads).

**NOTE:**

After a system reset, pipeline mode is disabled (FMREGOPT[0] is a 0). In other words, the A288 device powers up and comes out of reset in non-pipeline mode. Furthermore, setting the flash configuration mode bit (GBLCTRL[4]) will override pipeline mode.

**Flash Program and Erase**

The A288 device flash contains one 32K-byte memory array (or bank) and one 256K-byte bank, for a total of 288K-bytes of flash, and consists of eight sectors. These eight sectors are sized as follows:

SECTOR NO.	SEGMENT	LOW ADDRESS	HIGH ADDRESS	MEMORY ARRAYS (OR BANKS)
OTP	2K Bytes	0x0000_0000	0x0000_07FF	BANK0 (32K Bytes)
0	8K Bytes	0x0000_0000	0x0000_1FFF	
1	8K Bytes	0x0000_2000	0x0000_3FFF	
2	8K Bytes	0x0000_4000	0x0000_5FFF	
3	8K Bytes	0x0000_6000	0x0000_7FFF	
0	64K Bytes	0x0004_0000	0x0004_FFFF	BANK1 (256K Bytes)
1	64K Bytes	0x0005_0000	0x0005_FFFF	
2	64K Bytes	0x0006_0000	0x0006_FFFF	
3	64K Bytes	0x0007_0000	0x0007_FFFF	

The minimum size for an erase operation is one sector. The maximum size for a program operation is one 16-bit word.

**NOTE:**

The flash external pump voltage ( $V_{CCP}$ ) is required for all operations (program, erase, and read).

Execution can occur from one bank while programming/erasing any or all sectors of another bank. However, execution can not occur from any sector within a bank that is being programmed or erased.

For more detailed information on flash program and erase operations, see the *TMS470R1x F05 Flash Reference Guide* (literature number SPNU213).

**HET RAM**

The A288 device contains HET RAM. The HET RAM has a 64-instruction capability. The HET RAM is configurable by the SYS module to be addressed within the range of 0x0000\_0000 to 0xFFE0\_0000. The HET RAM is addressed through memory select 4.

**XOR Share**

The A288 HET peripheral contains the XOR-share feature. This feature allows two adjacent HET high-resolution channels to be XORed together, making it possible to output smaller pulses than a standard HET. For more detailed information on the HET XOR-share feature, see the *TMS470R1x High-End Timer (HET) Reference Guide* (literature number SPNU199).

**Peripheral Selects and Base Addresses**

The A288 device uses 10 of the 16 peripheral selects to decode the base addresses of the peripherals. These peripheral selects are fixed and transparent to the user because they are part of the decoding scheme used by the SYS module.

Control registers for the peripherals, SYS module, and flash begin at the base addresses shown in [Table 4](#).

**Table 4. A288 Peripherals, System Module, and Flash Base Addresses**

CONNECTING MODULE	ADDRESS RANGE		PERIPHERAL SELECTS
	BASE ADDRESS	ENDING ADDRESS	
SYSTEM	0xFFFF_FFD0	0x FFFF_FFFF	N/A
RESERVED	0xFFFF_FF70	0xFFFF_FF7F	N/A
DWD	0xFFFF_FF60	0x FFFF_FF6F	N/A
PSA	0xFFFF_FF40	0xFFFF_FF5F	N/A
CIM	0xFFFF_FF20	0xFFFF_FF3F	N/A
RTI	0xFFFF_FF00	0xFFFF_FF1F	N/A
DMA	0xFFFF_FE80	0xFFFF_FEFF	N/A
DEC	0xFFFF_FE00	0xFFFF_FE7F	N/A
RESERVED	0xFFFF_FD80	0xFFFF_FD7F	N/A
MMC	0xFFFF_FD00	0xFFFF_FD7F	N/A
IEM	0xFFFF_FC00	0xFFFF_FCFF	N/A
RESERVED	0xFFFF_FB00	0xFFFF_FBFF	N/A
RESERVED	0xFFFF_FA00	0xFFFF_FAFF	N/A
DMA CMD BUFFER	0xFFFF_F800	0xFFFF_F9FF	N/A
MSM	0xFFFF_F700	0xFFFF_F7FF	N/A
RESERVED	0xFFFF8_0000	0xFFFF_F6FF	N/A
RESERVED	0xFFFF7_FD00	0xFFFF7_FFFF	PS[0]
HET	0xFFFF7_FC00	0xFFFF7_FCF7	

**Table 4. A288 Peripherals, System Module, and Flash Base Addresses (continued)**

CONNECTING MODULE	ADDRESS RANGE		PERIPHERAL SELECTS
	BASE ADDRESS	ENDING ADDRESS	
RESERVED	0xFFF7_F900	0xFFF7_FBFF	PS[1]
SPI1	0xFFF7_F800	0xFFF7_F8FF	
RESERVED	0xFFF7_F600	0xFFF7_F7FF	PS[2]
SCI2	0xFFF7_F500	0xFFF7_F5FF	
SCI1	0xFFF7_F400	0xFFF7_F4FF	PS[3]
RESERVED	0xFFF7_F100	0xFFF7_F3FF	
MibADC	0xFFF7_F000	0xFFF7_F0FF	
ECP	0xFFF7_EF00	0xFFF7_EFFF	PS[4]
RESERVED	0xFFF7_EE00	0xFFF7_EEFF	
EBM	0xFFF7_ED00	0xFFF7_EDFF	
GIO	0xFFF7_EC00	0xFFF7_ECFE	
HECC	0xFFF7_EA00	0xFFF7_EBFF	PS[5]
RESERVED	0xFFF7_E800	0xFFF7_E9FF	
HECC RAM	0xFFF7_E600	0xFFF7_E7FF	PS[6]
RESERVED	0xFFF7_E400	0xFFF7_E5FF	
RESERVED	0xFFF7_E300	0xFFF7_E3FF	PS[7]
SCC2	0xFFF7_E200	0xFFF7_E2FF	
RESERVED	0xFFF7_E100	0xFFF7_E1FF	
SCC1	0xFFF7_E000	0xFFF7_E0FF	
RESERVED	0xFFF7_DF00	0xFFF7_DFFF	PS[8]
SCC2 RAM	0xFFF7_DE00	0xFFF7_DEFF	
RESERVED	0xFFF7_DD00	0xFFF7_DDFF	
SCC1 RAM	0xFFF7_DC00	0xFFF7_DCFE	
RESERVED	0xFFF7_DB00	0xFFF7_DBFF	PS[9]
I2C3	0xFFF7_DA00	0xFFF7_DAFF	
I2C2	0xFFF7_D900	0xFFF7_D9FF	
I2C1	0xFFF7_D800	0xFFF7_D8FF	
RESERVED	0xFFF7_D500	0xFFF7_D7FF	PS[10]
SPI2	0xFFF7_D400	0xFFF7_D4FF	
RESERVED	0xFFF7_CC00	0xFFF7_D3FF	PS[11] - PS[12]
RESERVED	0xFFF7_C900	0xFFF7_CBFF	PS[13]
C2S1b	0xFFF7_C800	0xFFF7_C8FF	
RESERVED	0xFFF7_C000	0xFFF7_C7FF	PS[14] - PS[15]
RESERVED	0xFFF0_0000	0xFFF7_BFFF	N/A
Flash Control Registers	0xFFE8_8000	0xFFE8_BFFF	N/A
RESERVED	0xFFF8_4024	0xFFF8_7FFF	N/A
MPU Control Registers	0xFFE8_4000	0xFFE8_4023	N/A
RESERVED	0xFFF8_0000	0xFFF8_3FFF	N/A

## Direct-Memory Access (DMA)

The direct-memory access (DMA) controller transfers data to and from any specified location in the A288 memory map (except for restricted memory locations such as the system control registers area). The DMA manages up to 16 channels, and supports data transfer for both on-chip and off-chip memories and peripherals. The DMA controller is connected to both the CPU and peripheral buses, enabling these data transfers to occur in parallel with CPU activity and thus maximizing overall system performance.

Although the DMA controller has two possible configurations for the A288 device, the DMA controller configuration is 32 control packets and 16 channels.

For the A288 DMA request hardwired configuration, see [Table 5](#).

**Table 5. DMA Request Lines Connections<sup>(1)</sup>**

MODULES	DMA REQUEST INTERRUPT SOURCES		DMA CHANNEL
EBM	Expansion Bus DMA request	EBDMAREQ0	DMAREQ[0]
SPI1	SPI1 end-receive	SPI1DMA0	DMAREQ[1]
SPI1	SPI1 end-transmit	SPI1DMA1	DMAREQ[2]
MibADC/I2C1	ADC EV/I2C1 read	MibADCDMA0/I2C1DMA0	DMAREQ[3]
MibADC/SCI1	ADC G1/SCI1 end-receive	MibADCDMA1/SCI1DMA0	DMAREQ[4]
MibADC/SCI1	ADC G2/SCI1 end-transmit	MibADCDMA2/SCI1DMA1	DMAREQ[5]
I2C1	I2C1 write	I2C1DMA1	DMAREQ[6]
SPI2	SPI2 end-receive	SPI2DMA0	DMAREQ[7]
SPI2	SPI2 end-transmit	SPI2DMA1	DMAREQ[8]
I2C2/C2S1b	I2C2 read end-receive/C2S1b end-receive	I2C2DMA0/C2SIDMA0	DMAREQ[9]
I2C2/C2S1b	I2C2 write end-transmit/C2S1b end-transmit	I2C2DMA1/C2SIDMA1	DMAREQ[10]
I2C3	I2C3 read	I2C3DMA0	DMAREQ[11]
I2C3	I2C3 write	I2C3DMA1	DMAREQ[12]
Reserved			DMAREQ[13]
SCI2	SCI2 end-receive	SCI2DMA0	DMAREQ[14]
SCI2	SCI2 end-transmit	SCI2DMA1	DMAREQ[15]

(1) For DMA channels with more than one assigned request source, only one of the sources listed can be the DMA request generator in a given application. The device has software control to ensure that there are no conflicts between requesting modules.

Each channel has two control packets attached to it, allowing the DMA to continuously load RAM and generate periodic interrupts so that the data can be read by the CPU. The control packets allow for the interrupt enable, and the channels determine the priority level of the interrupt.

DMA transfers occur in one of two modes:

- Non-request mode (used when transferring from memory to memory)
- Request mode (used when transferring from memory to peripheral)

For more detailed functional information on the DMA controller, see the *TMS470R1x Direct Memory Access (DMA) Controller Reference Guide* (literature number SPNU194).

## Interrupt Priority (IEM to CIM)

Interrupt requests originating from the A288 peripheral modules (i.e., SPI1 or SPI2; SCI1 or SCI2; RTI; etc.) are assigned to channels within the 48-channel interrupt expansion module (IEM) where, via programmable register mapping, these channels are then mapped to the 32-channel central interrupt manager (CIM) portion of the SYS module.

Programming multiple interrupt sources in the IEM to the same CIM channel effectively shares the CIM channel between sources.

The CIM request channels are maskable so that individual channels can be selectively disabled. All interrupt requests can be programmed in the CIM to be of either type:

- Fast interrupt request (FIQ)
- Normal interrupt request (IRQ)

The CIM prioritizes interrupts. The precedences of request channels decrease with ascending channel order in the CIM (0 [highest] and 31 [lowest] priority). For IEM-to-CIM default mapping, channel priorities, and their associated modules, see [Table 6](#).

**Table 6. Interrupt Priority (IEM and CIM)**

MODULES	INTERRUPT SOURCES	DEFAULT CIM INTERRUPT LEVEL/CHANNEL	IEM CHANNEL
SPI1	SPI1 end-transfer/overrun	0	0
RTI	COMP2 interrupt	1	1
RTI	COMP1 interrupt	2	2
RTI	TAP interrupt	3	3
SPI2	SPI2 end-transfer/overrun	4	4
GIO	GIO interrupt A	5	5
Reserved		6	6
HET	HET interrupt 1	7	7
I2C1	I2C1 interrupt	8	8
SCI1/SCI2	SCI1 or SCI2 error interrupt	9	9
SCI1	SCI1 receive interrupt	10	10
C2S1b	C2S1b interrupt	11	11
I2C2	I2C2 interrupt	12	12
SCC2	SCC2 interrupt A	13	13
SCC1	SCC1 interrupt A	14	14
Reserved		15	15
MibADC	MibADC end event conversion	16	16
SCI2	SCI2 receive interrupt	17	17
DMA	DMA interrupt 0	18	18
I2C3	I2C3 interrupt	19	19
SCI1	SCI1 transmit interrupt	20	20
System	SW interrupt (SSI)	21	21
Reserved		22	22
HET	HET interrupt 2	23	23
SCC2	SCC2 interrupt B	24	24
SCC1	SCC1 interrupt B	25	25
SCI2	SCI2 transmit interrupt	26	26
MibADC	MibADC end Group 1 conversion	27	27
DMA	DMA Interrupt 1	28	28
GIO	GIO interrupt B	29	29
MibADC	MibADC end Group 2 conversion	30	30
Reserved		31	31
Reserved		31	32–37
HECC	HECC interrupt A	31	38
HECC	HECC interrupt B	31	39
Reserved		31	40–47

For more detailed functional information on the IEM, see the *TMS470R1x Interrupt Expansion Module (IEM) Reference Guide* (literature number SPNU211). For more detailed functional information on the CIM, see the *TMS470R1x System Module Reference Guide* (literature number SPNU189).

## Expansion Bus Module (EBM)

The expansion bus module (EBM) is a standalone module used to bond out both general-purpose input/output pins and expansion bus interface pins. The module supports 8- and 16-bit expansion bus memory interface mappings, as well as mapping of the following expansion bus signals:

- 27-bit address bus (EBADDR[26:0]) for x8, 19-bit address bus (EBADDR[18:0]) for x16
- 8- or 16-bit data bus (EBDATA[7:0] or EBDATA[15:0])
- 2 write strobes ( $\overline{\text{EBWR}}[1:0]$ )
- 2 memory chip selects ( $\overline{\text{EBCS}}[6:5]$ )
- 1 output enable ( $\overline{\text{EBOE}}$ )
- 1 external hold signal for interfacing to slow memories ( $\overline{\text{EBHOLD}}$ )

Table 7 shows the multiplexing of I/O signals with the expansion bus interface signals. The mapping of these pins varies depending on the memory mode.

**Table 7. Expansion Bus Mux Mapping<sup>(1)</sup>**

GIO	EXPANSION BUS MODULE PINS <sup>(2)</sup>	
	x8	x16
GIOB[0]	EBDMAREQ[0]	EBDMAREQ[0]
GIOC[0]	$\overline{\text{EBOE}}$	$\overline{\text{EBOE}}$
GIOC[2:1]	$\overline{\text{EBWR}}[1:0]$	$\overline{\text{EBWR}}[1:0]$
GIOC[4:3]	$\overline{\text{EBCS}}[6:5]$	$\overline{\text{EBCS}}[6:5]$
GIOD[5:0]	EBADDR[5:0]	EBADDR[5:0]
GIOE[7:0]	EBDATA[7:0]	EBDATA[7:0]
GIOF[7:0]	EBADDR[13:6]	EBDATA[15:8]
GIOG[7:0]	EBADDR[21:14]	EBADDR[13:6]
GIOH[4:0]	EBADDR[26:22]	EBADDR[18:14]
GIOH[5]	$\overline{\text{EBHOLD}}$	$\overline{\text{EBHOLD}}$

(1) These mappings are controlled by the EBM mux control registers B-H (EBMXCRB - EBMXCRH) and the EBM control register 1 (EBMCR1). For GPIO functions, use GIODIRx, GIODINx, GIODOUTx, GIODSETx, and GIODCLR. For more detailed information, see the *TMS470R1x General-Purpose Input/Output (GIO) Reference Guide* (literature number SPNU192) and the *TMS470R1x Expansion Bus Module (EBM) Reference Guide* (literature number SPNU222).

(2) x8 refers to size of memory in 8-bits; x16 refers to size of memory in 16-bits.

Table 8 lists the names of the expansion bus interface signals and their functions.

**Table 8. Expansion Bus Pins**

PIN	DESCRIPTION
EBDMAREQ	Expansion bus DMA request
$\overline{\text{EBOE}}$	Expansion bus output enable
$\overline{\text{EBWR}}$	Expansion bus write strobe. $\overline{\text{EBWR}}[1]$ controls EBDATA[15:8] and $\overline{\text{EBWR}}[0]$ controls EBDATA[7:0].
$\overline{\text{EBCS}}$	Expansion bus chip select
EBADDR	Expansion bus address
EBDATA	Expansion bus data
$\overline{\text{EBHOLD}}$	Expansion bus hold: an external device connected to the expansion bus may assert this signal to add wait states to an expansion bus transaction.

**MibADC**

The multi-buffered analog-to-digital converter (MibADC) accepts an analog signal and converts the signal to a 10-bit digital value.

The A288 MibADC module can function in two modes: compatibility mode, where its programmer's model is compatible with the TMS470R1x ADC module and its digital results are stored in digital result registers; or in buffered mode, where the digital result registers are replaced with three FIFO buffers, one for each conversion group [event, group1 (G1), and group2 (G2)]. In buffered mode, the MibADC buffers can be serviced by interrupts or by the DMA.

**MibADC Event Trigger Enhancements**

The MibADC includes two major enhancements over the event-triggering capability of the TMS470R1x ADC.

- Both group 1 and the event group can be configured for event-triggered operation, providing up to two event-triggered groups.
- The trigger source and polarity can be selected individually for both group 1 and the event group from the options identified in Table 8.

**Table 9. MibADC Event Hookup Configuration**

EVENT NO.	SOURCE SELECT BITS FOR G1 OR EVENT (G1SRC[1:0] OR EVSRC[1:0])	SIGNAL PIN NAME
EVENT1	00	ADEVT
EVENT2	01	HET18
EVENT3	10	Reserved
EVENT4	11	Reserved

For group 1, these event-triggered selections are configured via the group 1 source select bits (G1SRC[1:0]) in the AD event source register (ADEVTSRC[5:4]). For the event group, these event-triggered selections are configured via the event group source select bits (EVSRC[1:0]) in the AD event source register (ADEVTSRC[1:0]).

For more detailed functional information on the MibADC, see the *TMS470R1x Multi-Buffered Analog-to-Digital Converter (MibADC) Reference Guide* (literature number SPNU206).

**JTAG Interface**

There are two main test access ports (TAPs) on the A288 device:

- TMS470R1x CPU TAP
- Device TAP for factory test

Some of the JTAG pins are shared among these two TAPs. The hookup is illustrated in [Figure 2](#).

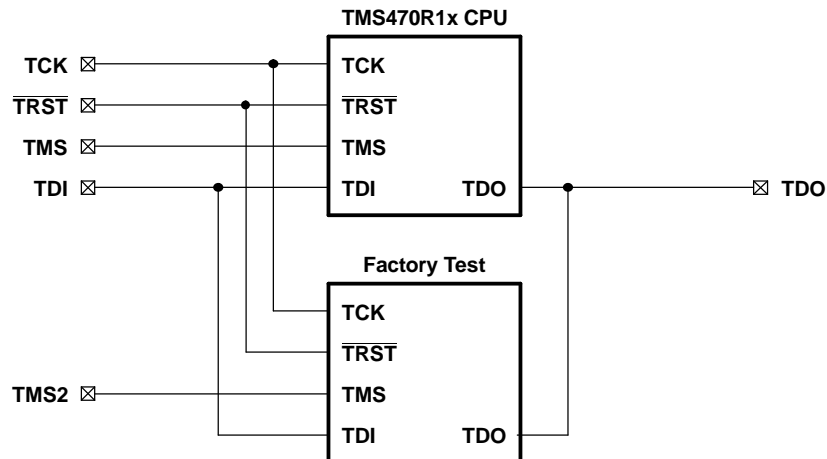

**Figure 2. JTAG Interface**



## Documentation Support

Extensive documentation supports all of the TMS470 microcontroller family generation of devices. The types of documentation available include: data sheets with design specifications; complete user's guides for all devices and development support tools; and hardware and software applications. Useful reference documentation includes:

- Bulletin
  - *TMS470 Microcontroller Family Product Bulletin* (literature number SPNB086)
- User's Guides
  - *TMS470R1x System Module Reference Guide* (literature number SPNU189)
  - *TMS470R1x General Purpose Input/Output (GPIO) Reference Guide* (literature number SPNU192)
  - *TMS470R1x Direct Memory Access (DMA) Controller Reference Guide* (literature number SPNU194)
  - *TMS470R1x Serial Peripheral Interface (SPI) Reference Guide* (literature number SPNU195)
  - *TMS470R1x Serial Communication Interface (SCI) Reference Guide* (literature number SPNU196)
  - *TMS470R1x Controller Area Network (CAN) Reference Guide* (literature number SPNU197)
  - *TMS470R1x High End Timer (HET) Reference Guide* (literature number SPNU199)
  - *TMS470R1x External Clock Prescale (ECP) Reference Guide* (literature number SPNU202)
  - *TMS470R1x MultiBuffered Analog to Digital (MibADC) Reference Guide* (literature number SPNU206)
  - *TMS470R1x ZeroPin Phase Locked Loop (ZPLL) Clock Module Reference Guide* (literature number SPNU212)
  - *TMS470R1x F05 Flash Reference Guide* (literature number SPNU213)
  - *TMS470R1x Class II Serial Interface B (C2SIb) Reference Guide* (literature number SPNU214)
  - *TMS470R1x Class II Serial Interface A (C2SIa) Reference Guide* (literature number SPNU218)
  - *TMS470R1x JTAG Security Module (JSM) Reference Guide* (literature number SPNU245)
  - *TMS470R1x Memory Security Module (MSM) Reference Guide* (literature number SPNU246)
  - *TMS470 Peripherals Overview Reference Guide* (literature number SPNU248)
- Errata Sheet
- *TMS470R1A288 TMS470 Microcontrollers Silicon Errata* (literature number SPNZ142)

### Device and Development-Support Tool Nomenclature

To designate the stages in the product development cycle, TI assigns prefixes to the part numbers of all DSP devices and support tools. Each DSP commercial family member has one of three prefixes: TMX, TMP, or TMS (e.g., **TMS470R1A288**). Texas Instruments recommends two of three possible prefix designators for its support tools: TMDX and TMDS. These prefixes represent evolutionary stages of product development from engineering prototypes (TMX/TMDX) through fully qualified production devices/tools (TMS/TMDS).

Device development evolutionary flow:

**TMX** Experimental device that is not necessarily representative of the final device's electrical specifications

**TMP** Final silicon die that conforms to the device's electrical specifications but has not completed quality and reliability verification

**TMS** Fully qualified production device

Support tool development evolutionary flow:

**TMDX** Development-support product that has not yet completed Texas Instruments internal qualification testing.

**TMDS** Fully qualified development-support product

TMX and TMP devices and TMDX development-support tools are shipped against the following disclaimer:

"Developmental product is intended for internal evaluation purposes."

TMS devices and TMDS development-support tools have been characterized fully, and the quality and reliability of the device have been demonstrated fully. TI's standard warranty applies.

Predictions show that prototype devices (TMX or TMP) have a greater failure rate than the standard production devices. Texas Instruments recommends that these devices not be used in any production system because their expected end-use failure rate still is undefined. Only qualified production devices are to be used.

[Figure 3](#) illustrates the numbering and symbol nomenclature for the TMS470R1x family.

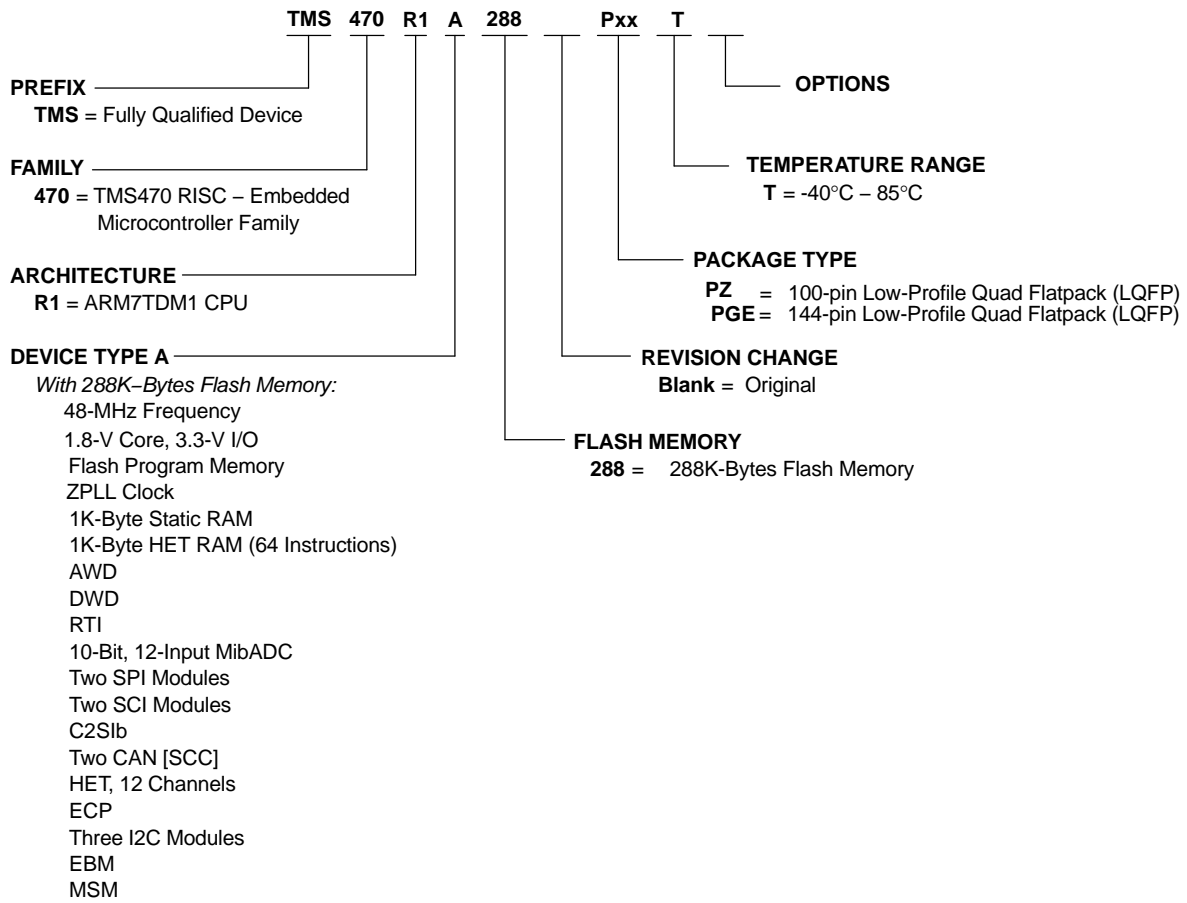
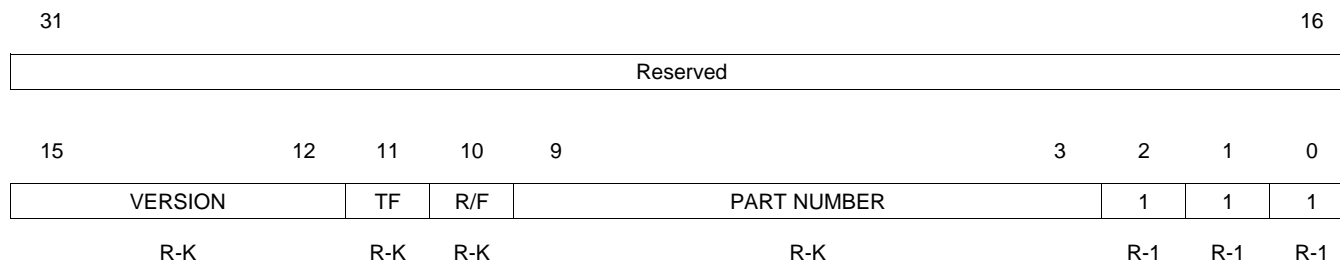

**Figure 3. TMS470R1x Family Nomenclature**

**Device Identification Code Register**

The device identification code register identifies the silicon version, the technology family (TF), a ROM or flash device, and an assigned device-specific part number (see [Figure 4](#)). The A288 device identification code register value is 0xn95F.

**Figure 4. TMS470 Device ID Bit Allocation Register [offset = FFFF\_FFF0h]**



LEGEND:  
R = Read only, -K = Value constant after  $\overline{\text{RESET}}$ ; -n = Value after  $\overline{\text{RESET}}$

**Table 10. TMS470 Device ID Bit Allocation Register Field Descriptions**

Bit	Field	Value	Description
31-16	Reserved		Reads are undefined and writes have no effect.
15-12	VERSION		Silicon version (revision) bits These bits identify the silicon version of the device. Initial device version numbers start at 0000.
11	TF	0 1	Technology family bit This bit distinguishes the technology family core power supply: 0 3.3 V for F10/C10 devices 1 1.8 V for F05/C05 devices
10	R/F	0 1	ROM/flash bit This bit distinguishes between ROM and flash devices: 0 Flash device 1 ROM device
9-3	PART NUMBER		Device-specific part number bits These bits identify the assigned device-specific part number. The assigned device-specific part number for the A288 device is 0101011.
2-0	1		Mandatory High Bits 2, 1, and 0 are tied high by default.

## Device Electrical Specifications and Timing Parameters

### Absolute Maximum Ratings

over operating free-air temperature range, A version unless otherwise noted<sup>(1)</sup>

Supply voltage range:	$V_{CC}$ <sup>(2)</sup>	-0.3 V to 2.5 V
Supply voltage range:	$V_{CCIO}$ , $V_{CCAD}$ , $V_{CCP}$ (flash pump) <sup>(2)</sup>	-0.3 V to 4.1V
Input voltage range:	All 5 V- tolerant input pins	-0.3 V to 6.0V
	All other input pins	-0.3 V to 4.1V
Input clamp current:	All 5-V tolerant pins, $\overline{PORRST}$ , $\overline{TRST}$ , $\overline{TEST}$ , and TCK ( $V_I < 0$ )	-20 mA <sup>(3)</sup>
	ADIN[0:11] $I_{IK}$ ( $V_I < 0$ or $V_I > V_{CCAD}$ )	±10 mA
	All other pins $I_{IK}$ ( $V_I < 0$ or $V_I > V_{CCAD}$ )	±20 mA
Operating free-air temperature ranges, $T_A$	A version	-40°C to 85°C
Operating junction temperature range, $T_J$		-40°C to 150°C
Storage temperature range, $T_{stg}$		-40°C to 150°C

(1) Stresses beyond those listed under "Absolute Maximum Ratings" may cause permanent damage to the device. These are stress ratings only, and functional operation of the device at these or any other conditions beyond those indicated under "Recommended Operating Conditions" is not implied. Exposure to absolute-maximum-rated conditions for extended periods may affect device reliability.

(2) All voltage values are with respect to their associated grounds.

(3) These pins do not have an internal clamp diode to a positive supply voltage.

### Device Recommended Operating Conditions<sup>(1)</sup>

			MIN	NOM	MAX	UNIT
$V_{CC}$	Digital logic supply voltage (Core)		1.71		2.05	V
$V_{CCIO}$	Digital logic supply voltage (I/O)		3		3.6	V
$V_{CCAD}$	MibADC supply voltage		3		3.6	V
$V_{CCP}$	Flash pump supply voltage		3		3.6	V
$V_{SS}$	Digital logic supply ground			0		V
$V_{SSAD}$	MibADC supply ground		-0.1		0.1	V
$T_A$	Operating free-air temperature	A version	-40		85	°C
$T_J$	Operating junction temperature		-40		150	°C

(1) All voltages are with respect to  $V_{SS}$ , except  $V_{CCAD}$ , which is with respect to  $V_{SSAD}$ .

**Electrical Characteristics**

over recommended operating free-air temperature range<sup>(1)</sup>

PARAMETER		TEST CONDITIONS	MIN	TYP	MAX	UNIT	
V <sub>hys</sub>	Input hysteresis		0.15			V	
V <sub>IL</sub>	Low-level input voltage	All inputs <sup>(2)</sup>	-0.3		0.8	V	
V <sub>IH</sub>	High-level input voltage	All inputs	2		V <sub>CCIO</sub> + 0.3	V	
V <sub>th</sub>	Input threshold voltage	AWD only <sup>(3)</sup>	1.35		1.8	V	
V <sub>OL</sub>	Low-level output voltage <sup>(4)</sup>	I <sub>OL</sub> = I <sub>OL</sub> MAX			0.2 V <sub>CCIO</sub>	V	
		I <sub>OL</sub> = 50 μA			0.2		
V <sub>OH</sub>	High-level output voltage <sup>(4)</sup>	I <sub>OH</sub> = I <sub>OH</sub> MIN	0.8 V <sub>CCIO</sub>			V	
		I <sub>OH</sub> = 50 μA	V <sub>CCIO</sub> - 0.2				
I <sub>IC</sub>	Input clamp current (I/O pins) <sup>(5)</sup>	V <sub>I</sub> < V <sub>SSIO</sub> - 0.3 or V <sub>I</sub> > V <sub>CCIO</sub> + 0.3	-2		2	mA	
I <sub>I</sub>	Input current (3.3 V input pins)	I <sub>IL</sub> Pulldown	V <sub>I</sub> = V <sub>SS</sub>	-1		1	μA
		I <sub>IH</sub> Pulldown	V <sub>I</sub> = V <sub>CCIO</sub>	5		40	
		I <sub>IL</sub> Pullup	V <sub>I</sub> = V <sub>SS</sub>	-40		-5	
		I <sub>IH</sub> Pullup	V <sub>I</sub> = V <sub>CCIO</sub>	-1		1	
		All other pins	No pullup or pulldown	-1		1	
	Input current (5 V tolerant input pins)	V <sub>I</sub> = V <sub>SS</sub>	-1		1	μA	
		V <sub>I</sub> = V <sub>CCIO</sub>	-1		1		
		V <sub>I</sub> = 5 V	0.5		20		
V <sub>I</sub> = 5.5 V		1		40			
I <sub>OL</sub>	Low-level output current	CLKOUT, AWD, TDI, TDO, TMS, TMS2	V <sub>OL</sub> = V <sub>OL</sub> MAX			8	mA
		R <sub>ST</sub>				4	
		All other 3.3 V I/O <sup>(6)</sup>				2	
		5 V tolerant				4	
I <sub>OH</sub>	High-level output current	CLKOUT, TDI, TDO, TMS, TMS2	V <sub>OH</sub> = V <sub>OH</sub> MIN	-8			mA
		R <sub>ST</sub>		-4			
		All other 3.3 V I/O <sup>(6)</sup>		-2			
		5 V tolerant		-4			
I <sub>CC</sub>	V <sub>CC</sub> Digital supply current (operating mode)	SYSCLK = 48 MHz, ICLK = 24 MHz, V <sub>CC</sub> = 2.05 V			115	mA	
		SYSCLK = 24 MHz, ICLK = 15 MHz, V <sub>CC</sub> = 2.05 V			90	mA	
	V <sub>CC</sub> Digital supply current (standby mode) <sup>(7)(8)</sup>	OSCIN = 4MHz, V <sub>CC</sub> = 2.05 V			750	μA	
	V <sub>CC</sub> Digital supply current (halt mode) <sup>(7)(8)</sup>	30°C version, no DC load, V <sub>CCIO</sub> = 2.05 V			30	μA	
		V <sub>CC</sub> = 2.05 V			160	μA	

- (1) Source currents (out of the device) are negative while sink currents (into the device) are positive.
- (2) This does not apply to the  $\overline{\text{PORRST}}$  pin. For  $\overline{\text{PORRST}}$  exceptions, see the *R<sub>ST</sub> and  $\overline{\text{PORRST}}$  timings* section.
- (3) These values help to determine the external RC network circuit. For more details, see the *TMS470R1x System Module Reference Guide* (literature number SPNU189).
- (4) V<sub>OL</sub> and V<sub>OH</sub> are linear with respect to the amount of load current (I<sub>OL</sub>/I<sub>OH</sub>) applied.
- (5) Parameter does not apply to input-only or output-only pins.
- (6) The 2 mA buffers on this device are called zero-dominant buffers. If two of these buffers are shorted together and one is outputting a low level and the other is outputting a high level, the resulting value will always be low.
- (7) For flash banks/pumps in sleep mode.
- (8) For reduced power consumption in low power mode, CANSRX and CANSTX should be driven output LOW.

## Electrical Characteristics (continued)

over recommended operating free-air temperature range

PARAMETER		TEST CONDITIONS	MIN	TYP	MAX	UNIT
$I_{CCIO}$	$V_{CCIO}$ Digital supply current (operating mode)	No DC load, $V_{CCIO} = 3.6\text{ V}^{(9)}$			15	mA
	$V_{CCIO}$ Digital supply current (standby mode) <sup>(8)</sup>	No DC load, $V_{CCIO} = 3.6\text{ V}^{(9)}$			10	$\mu\text{A}$
	$V_{CCIO}$ Digital supply current (halt mode) <sup>(8)</sup>	30°C version, no DC load, $V_{CCIO} = 3.6\text{ V}^{(9)}$			5	$\mu\text{A}$
		No DC load, $V_{CCIO} = 3.6\text{ V}^{(9)}$			5	$\mu\text{A}$
$I_{CCAD}$	$V_{CCAD}$ supply current (operating mode)	All frequencies, $V_{CCAD} = 3.6\text{ V}$			25	mA
	$V_{CCAD}$ supply current (standby mode)	No DC load, $V_{CCAD} = 3.6\text{ V}^{(9)}$			10	$\mu\text{A}$
	$V_{CCAD}$ supply current (halt mode)	30°C version, no DC load, $V_{CCAD} = 3.6\text{ V}$			5	$\mu\text{A}$
		$V_{CCAD} = 3.6\text{ V}$			5	$\mu\text{A}$
$I_{CCP}$	$V_{CCP}$ pump supply current	$V_{CCP} = 3.6\text{ V}$ read operation			60	mA
		$V_{CCP} = 3.6\text{ V}$ program and erase			70	mA
		$V_{CCP} = 3.6\text{ V}$ standby mode operation <sup>(7)</sup>			10	$\mu\text{A}$
		30°C version, no DC load, $V_{CCP} = 3.6\text{ V}$ halt mode operation <sup>(7)</sup>			5	$\mu\text{A}$
		$V_{CCP} = 3.6\text{ V}$ halt mode operation <sup>(7)</sup>			5	$\mu\text{A}$
$C_I$	Input capacitance			2	pF	
$C_O$	Output capacitance			3	pF	

(9) I/O pins configured as inputs or outputs with no load. All pulldown inputs  $\leq 0.2\text{ V}$ . All pullup inputs  $\geq V_{CCIO} - 0.2\text{ V}$ .

## Parameter Measurement Information

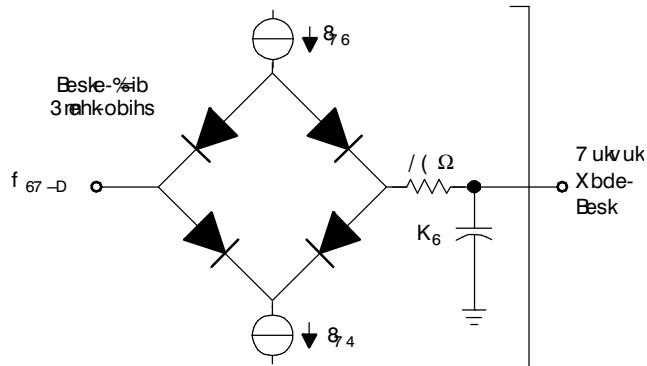

Where:  $I_{OL} = I_{OL\text{ MAX}}$  for the respective pin<sup>(A)</sup>  
 $I_{OH} = I_{OH\text{ MIN}}$  for the respective pin<sup>(A)</sup>  
 $V_{LOAD} = 1.5\text{ V}$   
 $C_L = 150\text{-pF}$  typical load-circuit capacitance<sup>(B)</sup>

- For these values, see the "Electrical Characteristics over Recommended Operating Free-Air Temperature Range" table.
- All timing parameters measured using an external load capacitance of 150 pF unless otherwise noted.

**Figure 5. Test Load Circuit**

## Timing Parameter Symbolology

Timing parameter symbols have been created in accordance with JEDEC Standard 100. To shorten the symbols, some of the pin names and other related terminology have been abbreviated as follows:

CM	Compaction, CMPCT	RD	Read
CO	CLKOUT	RST	Reset, $\overline{\text{RST}}$
ER	Erase	RX	SCInRX
ICLK	Interface clock	S	Slave mode
M	Master mode	SCC	SCInCLK
OSC, OSC1	OSCIN	SIMO	SPInSIMO
OSCO	OSCOOUT	SOMI	SPInSOMI
P	Program, PROG	SPC	SPInCLK
R	Ready	SYS	System clock
R0	Read margin 0, RDMRGN0	TX	SCInTX
R1	Read margin 1, RDMRGN1		

Lowercase subscripts and their meanings are:

a	access time	r	rise time
c	cycle time (period)	su	setup time
d	delay time	t	transition time
f	fall time	v	valid time
h	hold time	w	pulse duration (width)

The following additional letters are used with these meanings:

H	High	X	Unknown, changing, or don't care level
L	Low	Z	High impedance
V	Valid		



### External Reference Resonator/Crystal Oscillator Clock Option

The oscillator is enabled by connecting the appropriate fundamental 4-10 MHz resonator/crystal and load capacitors across the external OSCIN and OSCOUT pins as shown in Figure 6a. The oscillator is a single-stage inverter held in bias by an integrated bias resistor. This resistor is disabled during leakage test measurement and HALT mode. **TI strongly encourages each customer to submit samples of the device to the resonator/crystal vendors for validation.** The vendors are equipped to determine what load capacitors will best tune their resonator/crystal to the microcontroller device for optimum start-up and operation over temperature/voltage extremes.

An external oscillator source can be used by connecting a 1.8-V clock signal to the OSCIN pin and leaving the OSCOUT pin unconnected (open) as shown in Figure 6b.

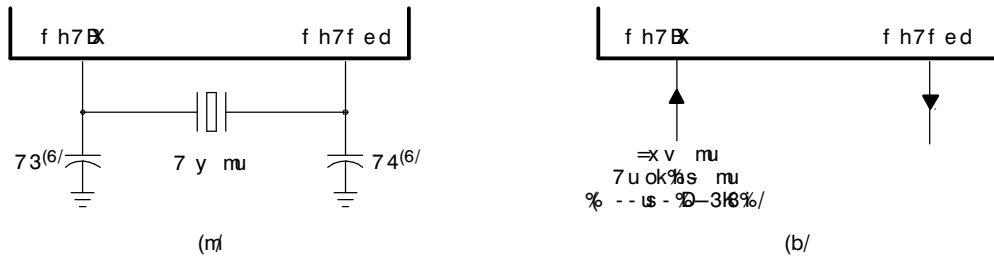

- A. The values of C1 and C2 should be provided by the resonator/crystal vendor.

**Figure 6. Crystal/Clock Connection**

## ZPLL AND CLOCK SPECIFICATIONS

### Timing Requirements for ZPLL Circuits Enabled or Disabled

		MIN	TYP	MAX	UNIT
$f_{(OSC)}$	Input clock frequency	4		10	MHz
$t_{c(O SC)}$	Cycle time, OSCIN	100			ns
$t_{w(O SCIL)}$	Pulse duration, OSCIN low	15			ns
$t_{w(O SCIH)}$	Pulse duration, OSCIN high	15			ns
$f_{(OSCRST)}$	OSC FAIL frequency <sup>(1)</sup>		53		kHz

(1) Causes a device reset (specifically a clock reset) by setting the RST OSC FAIL (GLBCTRL[15]) and the OSC FAIL flag (GLBSTAT[1]) bits equal to 1. For more detailed information on these bits and device resets, see the *TMS470R1x System Module Reference Guide* (literature number SPNU189).

### Switching Characteristics Over Recommended Operating Conditions for Clocks<sup>(1)(2)</sup>

PARAMETER		TEST CONDITIONS <sup>(3)</sup>	MIN	MAX	UNIT
$f_{(SYS)}$	System clock frequency <sup>(4)</sup>	Pipeline mode enabled		48	MHz
		Pipeline mode disabled		24	MHz
$f_{(CONFIG)}$	System clock frequency - flash config mode			24	MHz
$f_{(ICLK)}$	Interface clock frequency	Pipeline mode enabled		25	MHz
		Pipeline mode disabled		24	MHz
$f_{(ECLK)}$	External clock output frequency for ECP module	Pipeline mode enabled		25	MHz
		Pipeline mode disabled		24	MHz
$t_{c(SYS)}$	Cycle time, system clock	Pipeline mode enabled	20.8		ns
		Pipeline mode disabled	41.6		ns
$t_{c(CONFIG)}$	Cycle time, system clock - flash config mode		41.6		ns
$t_{c(ICLK)}$	Cycle time, interface clock	Pipeline mode enabled	40		ns
		Pipeline mode disabled	41.6		ns
$t_{c(ECLK)}$	Cycle time, ECP module external clock output	Pipeline mode enabled	40		ns
		Pipeline mode disabled	41.6		ns

(1)  $f_{(SYS)} = M \times f_{(OSC)} / R$ , where  $M = \{8\}$ ,  $R = \{1,2,3,4,5,6,7,8\}$  when PLLDIS = 0. R is the system-clock divider determined by the CLKDIVPRE [2:0] bits in the global control register (GLBCTRL[2:0]) and M is the PLL multiplier determined by the MULT4 bit also in the GLBCTRL register (GLBCTRL.3).

$f_{(SYS)} = f_{(OSC)} / R$ , where  $R = \{1,2,3,4,5,6,7,8\}$  when PLLDIS = 1.

$f_{(ICLK)} = f_{(SYS)} / X$ , where  $X = \{1,2,3,4,5,6,7,8,9,10,11,12,13,14,15,16\}$ . X is the interface clock divider ratio determined by the PCR0[4:1] bits in the SYS module.

(2)  $f_{(ECLK)} = f_{(ICLK)} / N$ , where  $N = \{1 \text{ to } 256\}$ . N is the ECP prescale value defined by the ECPCTRL[7:0] register bits in the ECP module.

(3) Pipeline mode enabled or disabled is determined by the ENPIPE bit (FMREGOPT[0]).

(4) Flash Vread must be set to 5 V to achieve maximum system clock frequency.

Switching Characteristics Over Recommended Operating Conditions for External Clocks<sup>(1)(2)(3)</sup>

(see Figure 7 and Figure 8)

PARAMETER		TEST CONDITIONS	MIN	MAX	UNIT
$t_{w(COL)}$	Pulse duration, CLKOUT low	SYSCLOCK or MCLK <sup>(4)</sup>	$0.5t_{c(SYS)} - t_f$		ns
		ICLK: X is even or 1 <sup>(5)</sup>	$0.5t_{c(ICK)} - t_f$		
		ICLK: X is odd and not 1 <sup>(5)</sup>	$0.5t_{c(ICK)} + 0.5t_{c(SYS)} - t_f$		
$t_{w(COH)}$	Pulse duration, CLKOUT high	SYSCLOCK or MCLK <sup>(4)</sup>	$0.5t_{c(SYS)} - t_r$		ns
		ICLK: X is even or 1 <sup>(5)</sup>	$0.5t_{c(ICK)} - t_r$		
		ICLK: X is odd and not 1 <sup>(5)</sup>	$0.5t_{c(ICK)} - 0.5t_{c(SYS)} - t_r$		
$t_{w(EOL)}$	Pulse duration, ECLK low	N is even and X is even or odd	$0.5t_{c(ECLK)} - t_f$		ns
		N is odd and X is even	$0.5t_{c(ECLK)} - t_f$		
		N is odd and X is odd and not 1	$0.5t_{c(ECLK)} + 0.5t_{c(SYS)} - t_f$		
$t_{w(EOH)}$	Pulse duration, ECLK high	N is even and X is even or odd	$0.5t_{c(ECLK)} - t_r$		ns
		N is odd and X is even	$0.5t_{c(ECLK)} - t_r$		
		N is odd and X is odd and not 1	$0.5t_{c(ECLK)} - 0.5t_{c(SYS)} - t_r$		

- (1) X = {1,2,3,4,5,6,7,8,9,10,11,12,13,14,15,16}. X is the interface clock divider ratio determined by the PCR0[4:1] bits in the SYS module.
- (2) N = {1 to 256}. N is the ECP prescale value defined by the ECPCTRL[7:0] register bits in the ECP module.
- (3) CLKOUT/ECLK pulse durations (low/high) are a function of the OSCIN pulse durations when PLLDIS is active.
- (4) Clock source bits are selected as either SYSCLOCK (CLKCNTL[6:5] = 11 binary) or MCLK (CLKCNTL[6:5] = 10 binary).
- (5) Clock source bits are selected as ICLK (CLKCNTL[6:5] = 01 binary).

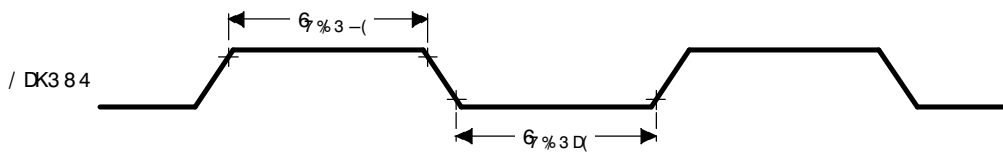

Figure 7. CLKOUT Timing Diagram

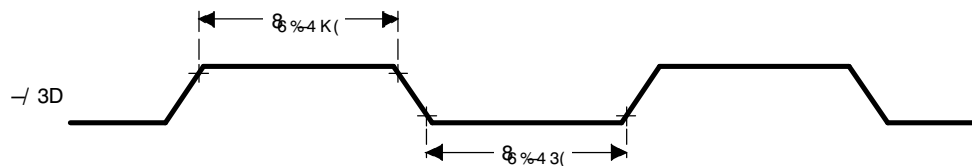

Figure 8. ECLK Timing Diagram

## RST AND PORRST TIMINGS

### Timing Requirements for PORRST

(see Figure 9)

		MIN	MAX	UNIT
V <sub>CCPORL</sub>	V <sub>CC</sub> low supply level when $\overline{\text{PORRST}}$ must be active during power up		0.6	V
V <sub>CCPORH</sub>	V <sub>CC</sub> high supply level when $\overline{\text{PORRST}}$ must remain active during power up and become active during power down	1.5		V
V <sub>CCIOPORL</sub>	V <sub>CCIO</sub> low supply level when $\overline{\text{PORRST}}$ must be active during power up		1.1	V
V <sub>CCIOPORH</sub>	V <sub>CCIO</sub> high supply level when $\overline{\text{PORRST}}$ must remain active during power up and become active during power down	2.75		V
V <sub>IL</sub>	Low-level input voltage after V <sub>CCIO</sub> > V <sub>CCIOPORH</sub>		0.2 V <sub>CCIO</sub>	V
V <sub>IL(PORRST)</sub>	Low-level input voltage of $\overline{\text{PORRST}}$ before V <sub>CCIO</sub> > V <sub>CCIOPORL</sub>		0.5	V
t <sub>su(PORRST)r</sub>	Setup time, $\overline{\text{PORRST}}$ active before V <sub>CCIO</sub> > V <sub>CCIOPORL</sub> during power up	0		ms
t <sub>su(VCCIO)r</sub>	Setup time, V <sub>CCIO</sub> > V <sub>CCIOPORL</sub> before V <sub>CC</sub> > V <sub>CCPORL</sub>	0		ms
t <sub>h(PORRST)r</sub>	Hold time, $\overline{\text{PORRST}}$ active after V <sub>CC</sub> > V <sub>CCPORH</sub>	1		ms
t <sub>su(PORRST)f</sub>	Setup time, $\overline{\text{PORRST}}$ active before V <sub>CC</sub> ≤ V <sub>CCPORH</sub> during power down	8		μs
t <sub>h(PORRST)rio</sub>	Hold time, $\overline{\text{PORRST}}$ active after V <sub>CC</sub> > V <sub>CCIOPORH</sub>	1		ms
t <sub>h(PORRST)d</sub>	Hold time, $\overline{\text{PORRST}}$ active after V <sub>CC</sub> < V <sub>CCPORL</sub>	0		ms
t <sub>su(PORRST)rio</sub>	Setup time, $\overline{\text{PORRST}}$ active before V <sub>CC</sub> ≤ V <sub>CCIOPORH</sub> during power down	0		ns
t <sub>su(VCCIO)f</sub>	Setup time, V <sub>CC</sub> < V <sub>CCPORL</sub> before V <sub>CCIO</sub> < V <sub>CCIOPORL</sub>	0		ns

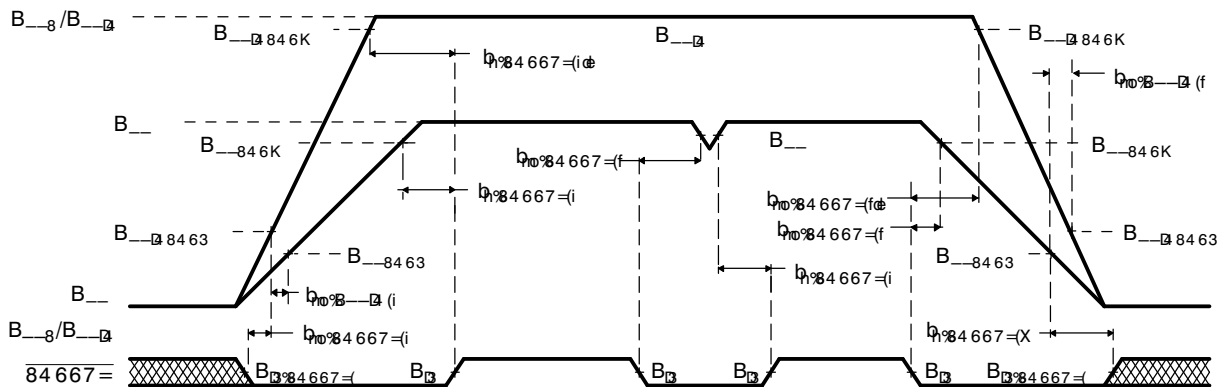

Figure 9.  $\overline{\text{PORRST}}$  Timing Diagram

### Switching Characteristics Over Recommended Operating Conditions for RST<sup>(1)</sup>

PARAMETER		MIN	MAX	UNIT
t <sub>v(RST)</sub>	Valid time, RST active after $\overline{\text{PORRST}}$ inactive	4112t <sub>c(OSC)</sub>		ns
	Valid time, $\overline{\text{RST}}$ active (all others)	8t <sub>c(SYS)</sub>		
t <sub>fsu</sub>	Flash start-up time, from $\overline{\text{RST}}$ inactive to fetch of first instruction from flash (flash pump stabilization time)	670t <sub>c(OSC)</sub>		ns

(1) Specified values do NOT include rise/fall times. For rise and fall timings, see the "Switching Characteristics for Output Timings versus Load Capacitance" table.

### JTAG SCAN INTERFACE TIMING

(JTAG Clock Specification 10-MHz and 50-pF Load on TDO Output)

		MIN	MAX	UNIT
$t_{c(JTAG)}$	Cycle time, JTAG low and high period	50		ns
$t_{su(TDI/TMS - TCKr)}$	Setup time, TDI, TMS before TCK rise (TCKr)	15		ns
$t_h(TCKr - TDI/TMS)$	Hold time, TDI, TMS after TCKr	15		ns
$t_h(TCKf - TDO)$	Hold time, TDO after TCKf	10		ns
$t_d(TCKf - TDO)$	Delay time, TDO valid after TCK fall (TCKf)		45	ns

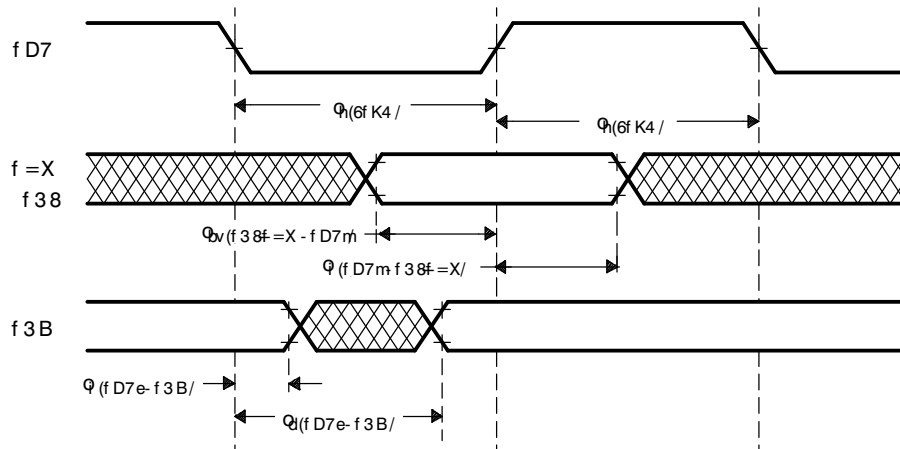

Figure 10. JTAG Scan Timings

**OUTPUT TIMINGS**

**Switching Characteristics for Output Timings versus Load Capacitance ( $C_L$ )**

(see Figure 11)

PARAMETER		MIN	MAX	UNIT	
$t_r$	Rise time, AWD, CLKOUT, TDI, TDO, TMS, TMS2	$C_L = 15\text{ pF}$	0.5	2.5	ns
		$C_L = 50\text{ pF}$	1.5	5.0	
		$C_L = 100\text{ pF}$	3	9.0	
		$C_L = 150\text{ pF}$	4.5	12.5	
$t_f$	Fall time, AWD, CLKOUT, TDI, TDO, TMS, TMS2	$C_L = 15\text{ pF}$	0.5	2.5	ns
		$C_L = 50\text{ pF}$	1.5	5.0	
		$C_L = 100\text{ pF}$	3	9.0	
		$C_L = 150\text{ pF}$	4.5	12.5	
$t_r$	Rise time, $\overline{\text{RST}}$	$C_L = 15\text{ pF}$	2.5	8	ns
		$C_L = 50\text{ pF}$	5	14	
		$C_L = 100\text{ pF}$	9	23	
		$C_L = 150\text{ pF}$	13	32	
$t_f$	Fall time, $\overline{\text{RST}}$	$C_L = 15\text{ pF}$	2.5	8	ns
		$C_L = 50\text{ pF}$	5	14	
		$C_L = 100\text{ pF}$	9	23	
		$C_L = 150\text{ pF}$	13	32	
$t_r$	Rise time, 4 mA, 5 V tolerant pins	$C_L = 15\text{ pF}$	3	10	ns
		$C_L = 50\text{ pF}$	3.5	12	
		$C_L = 100\text{ pF}$	7	21	
		$C_L = 150\text{ pF}$	9	28	
$t_f$	Fall time, 4 mA, 5 V tolerant pins	$C_L = 15\text{ pF}$	2	8	ns
		$C_L = 50\text{ pF}$	2.5	9	
		$C_L = 100\text{ pF}$	8	25	
		$C_L = 150\text{ pF}$	11	35	
$t_r$	Rise time, all other output pins	$C_L = 15\text{ pF}$	2.5	10	ns
		$C_L = 50\text{ pF}$	6.0	25	
		$C_L = 100\text{ pF}$	12	45	
		$C_L = 150\text{ pF}$	18	65	
$t_f$	Fall time, all other output pins	$C_L = 15\text{ pF}$	3	10	ns
		$C_L = 50\text{ pF}$	8.5	25	
		$C_L = 100\text{ pF}$	16	45	
		$C_L = 150\text{ pF}$	23	65	

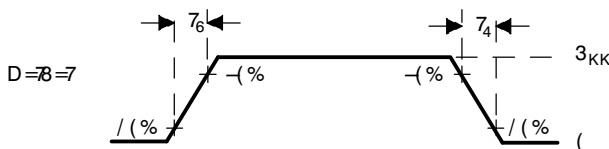

**Figure 11. CMOS-Level Outputs**

## INPUT TIMINGS

### Timing Requirements for Input Timings<sup>(1)</sup>

(see Figure 12)

		MIN	MAX	UNIT
$t_{pw}$	Input minimum pulse width	$t_{c(ICKL)} + 10$		ns

(1)  $t_{c(ICKL)}$  = interface clock cycle time =  $1 / f_{(ICKL)}$

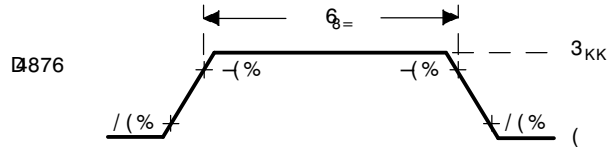

Figure 12. CMOS-Level Inputs

## FLASH TIMINGS

### Timing Requirements for Program Flash<sup>(1)</sup>

		MIN	TYP	MAX	UNIT
$t_{prog(16-bit)}$	Half word (16-bit) programming time	4	16	200	$\mu$ s
$t_{prog(Total)}$	288K-byte programming time <sup>(2)</sup>		2	8	s
$t_{erase(sector)}$	Sector erase time		5	15	s
$t_{wec}$	Write/erase cycles at $T_A = 105^\circ\text{C}$	1000	10000		cycles
$t_{fp(RST)}$	Flash pump settling time from $\overline{\text{RST}}$ to SLEEP		$134t_{c(SYS)}$		ns
$t_{fp(SLEEP)}$	Initial flash pump settling time from SLEEP to STANDBY		$134t_{c(SYS)}$		
$t_{fp(STANDBY)}$	Initial flash pump settling time from STANDBY to ACTIVE		$67t_{c(SYS)}$		

- (1) For more detailed information on the flash core sectors, see the *flash program and erase* section of this data sheet.  
 (2) The 288K-byte programming time includes overhead of state machine.

## SPI<sub>n</sub> MASTER MODE TIMING PARAMETERS

### SPI<sub>n</sub> Master Mode External Timing Parameters

(CLOCK PHASE = 0, SPI<sub>n</sub>CLK = output, SPI<sub>n</sub>SIMO = output, and SPI<sub>n</sub>SOMI = input)<sup>(1)(2)(3)</sup> (see Figure 13)

NO.			MIN	MAX	UNIT
1	$t_{c(SPC)M}$	Cycle time, SPI <sub>n</sub> CLK <sup>(4)</sup>	100	$256t_{c(ICLK)}$	ns
2 <sup>(5)</sup>	$t_{w(SPCH)M}$	Pulse duration, SPI <sub>n</sub> CLK high (clock polarity = 0)	$0.5t_{c(SPC)M} - t_r$	$0.5t_{c(SPC)M} + 5$	ns
	$t_{w(SPCL)M}$	Pulse duration, SPI <sub>n</sub> CLK low (clock polarity = 1)	$0.5t_{c(SPC)M} - t_f$	$0.5t_{c(SPC)M} + 5$	
3 <sup>(5)</sup>	$t_{w(SPCL)M}$	Pulse duration, SPI <sub>n</sub> CLK low (clock polarity = 0)	$0.5t_{c(SPC)M} - t_f$	$0.5t_{c(SPC)M} + 5$	ns
	$t_{w(SPCH)M}$	Pulse duration, SPI <sub>n</sub> CLK high (clock polarity = 1)	$0.5t_{c(SPC)M} - t_r$	$0.5t_{c(SPC)M} + 5$	
4 <sup>(5)</sup>	$t_{d(SPCH-SIMO)M}$	Delay time, SPI <sub>n</sub> CLK high to SPI <sub>n</sub> SIMO valid (clock polarity = 0)		10	ns
	$t_{d(SPCL-SIMO)M}$	Delay time, SPI <sub>n</sub> CLK low to SPI <sub>n</sub> SIMO valid (clock polarity = 1)		10	
5 <sup>(5)</sup>	$t_{v(SPCL-SIMO)M}$	Valid time, SPI <sub>n</sub> SIMO data valid after SPI <sub>n</sub> CLK low (clock polarity = 0)	$t_{c(SPC)M} - 5 - t_f$		ns
	$t_{v(SPCH-SIMO)M}$	Valid time, SPI <sub>n</sub> SIMO data valid after SPI <sub>n</sub> CLK high (clock polarity = 1)	$t_{c(SPC)M} - 5 - t_r$		
6 <sup>(5)</sup>	$t_{su(SOMI-SPCL)M}$	Setup time, SPI <sub>n</sub> SOMI before SPI <sub>n</sub> CLK low (clock polarity = 0)	6		ns
	$t_{su(SOMI-SPCH)M}$	Setup time, SPI <sub>n</sub> SOMI before SPI <sub>n</sub> CLK high (clock polarity = 1)	6		
7 <sup>(5)</sup>	$t_{v(SPCL-SOMI)M}$	Valid time, SPI <sub>n</sub> SOMI data valid after SPI <sub>n</sub> CLK low (clock polarity = 0)	4		ns
	$t_{v(SPCH-SOMI)M}$	Valid time, SPI <sub>n</sub> SOMI data valid after SPI <sub>n</sub> CLK high (clock polarity = 1)	4		

(1) The MASTER bit (SPI<sub>n</sub>CTRL2.3) is set and the CLOCK PHASE bit (SPI<sub>n</sub>CTRL2[0]) is cleared.

(2)  $t_{c(ICLK)}$  = interface clock cycle time =  $1 / f_{(ICLK)}$

(3) For rise and fall timings, see the "Switching Characteristics for Output Timings versus Load Capacitance" table.

(4) When the SPI is in master mode, the following must be true:

For PS values from 1 to 255:  $t_{c(SPC)M} \geq (PS + 1)t_{c(ICLK)} \geq 100$  ns, where PS is the prescale value set in the SPI<sub>n</sub>CTL1[12:5] register bits.

For PS values of 0:  $t_{c(SPC)M} = 2t_{c(ICLK)} \geq 100$  ns.

(5) The active edge of the SPI<sub>n</sub>CLK signal referenced is controlled by the CLOCK POLARITY bit (SPI<sub>n</sub>CTRL2[1]).

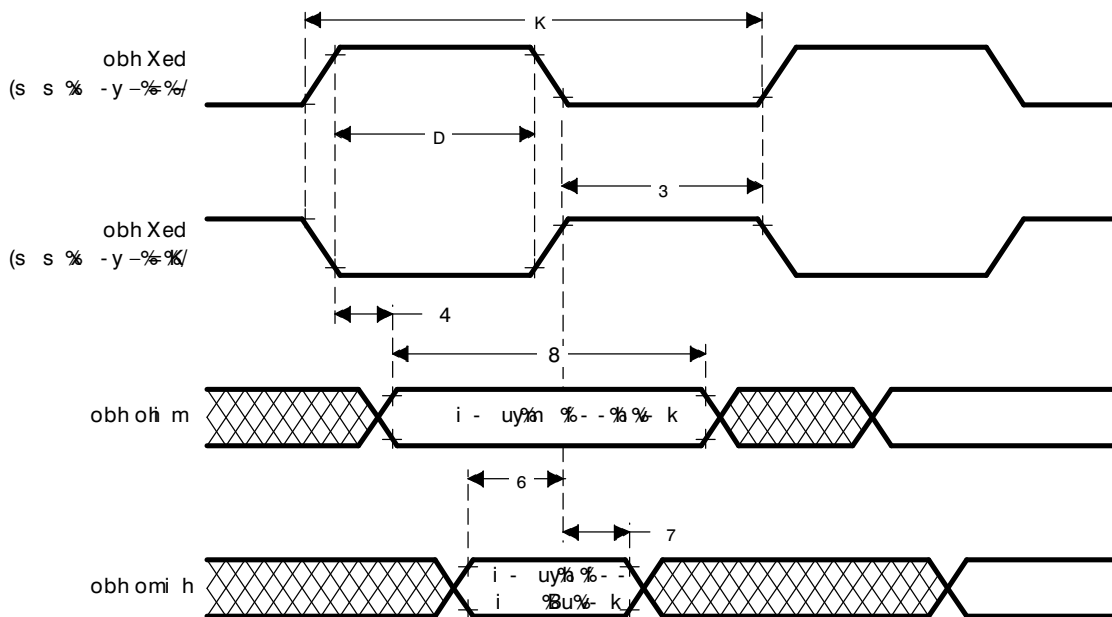

Figure 13. SPI<sub>n</sub> Master Mode External Timing (CLOCK PHASE = 0)



### SPIn Master Mode External Timing Parameters

(CLOCK PHASE = 1, SPInCLK = output, SPInSIMO = output, and SPInSOMI = input) <sup>(1)(2)(3)</sup> (see Figure 14)

NO.			MIN	MAX	UNIT
1	$t_{c(SPC)M}$	Cycle time, SPInCLK <sup>(4)</sup>	100	$256t_{c(ICLK)}$	ns
2 <sup>(5)</sup>	$t_{w(SPCH)M}$	Pulse duration, SPInCLK high (clock polarity = 0)	$0.5t_{c(SPC)M} - t_r$	$0.5t_{c(SPC)M} + 5$	ns
	$t_{w(SPCL)M}$	Pulse duration, SPInCLK low (clock polarity = 1)	$0.5t_{c(SPC)M} - t_f$	$0.5t_{c(SPC)M} + 5$	
3 <sup>(5)</sup>	$t_{w(SPCL)M}$	Pulse duration, SPInCLK low (clock polarity = 0)	$0.5t_{c(SPC)M} - t_f$	$0.5t_{c(SPC)M} + 5$	ns
	$t_{w(SPCH)M}$	Pulse duration, SPInCLK high (clock polarity = 1)	$0.5t_{c(SPC)M} - t_r$	$0.5t_{c(SPC)M} + 5$	
4 <sup>(5)</sup>	$t_{v(SIMO-SPCH)M}$	Valid time, SPInCLK high after SPInSIMO data valid (clock polarity = 0)	$0.5t_{c(SPC)M} - 10$		ns
	$t_{v(SIMO-SPCL)M}$	Valid time, SPInCLK low after SPInSIMO data valid (clock polarity = 1)	$0.5t_{c(SPC)M} - 10$		
5 <sup>(5)</sup>	$t_{v(SPCH-SIMO)M}$	Valid time, SPInSIMO data valid after SPInCLK high (clock polarity = 0)	$0.5t_{c(SPC)M} - 5 - t_r$		ns
	$t_{v(SPCL-SIMO)M}$	Valid time, SPInSIMO data valid after SPInCLK low (clock polarity = 1)	$0.5t_{c(SPC)M} - 5 - t_f$		
6 <sup>(5)</sup>	$t_{su(SOMI-SPCH)M}$	Setup time, SPInSOMI before SPInCLK high (clock polarity = 0)	6		ns
	$t_{su(SOMI-SPCL)M}$	Setup time, SPInSOMI before SPInCLK low (clock polarity = 1)	6		
7 <sup>(5)</sup>	$t_{v(SPCH-SOMI)M}$	Valid time, SPInSOMI data valid after SPInCLK high (clock polarity = 0)	4		ns
	$t_{v(SPCL-SOMI)M}$	Valid time, SPInSOMI data valid after SPInCLK low (clock polarity = 1)	4		

(1) The MASTER bit (SPInCTRL2.3) is set and the CLOCK PHASE bit (SPInCTRL2[0]) is set.

(2)  $t_{c(ICLK)}$  = interface clock cycle time =  $1 / f_{(ICLK)}$

(3) For rise and fall timings, see the "Switching Characteristics for Output Timings versus Load Capacitance" table.

(4) When the SPI is in master mode, the following must be true:

For PS values from 1 to 255:  $t_{c(SPC)M} \geq (PS + 1)t_{c(ICLK)} \geq 100$  ns, where PS is the prescale value set in the SPInCTL1[12:5] register bits.

For PS values of 0:  $t_{c(SPC)M} = 2t_{c(ICLK)} \geq 100$  ns.

(5) The active edge of the SPInCLK signal referenced is controlled by the CLOCK POLARITY bit (SPInCTRL2[1]).

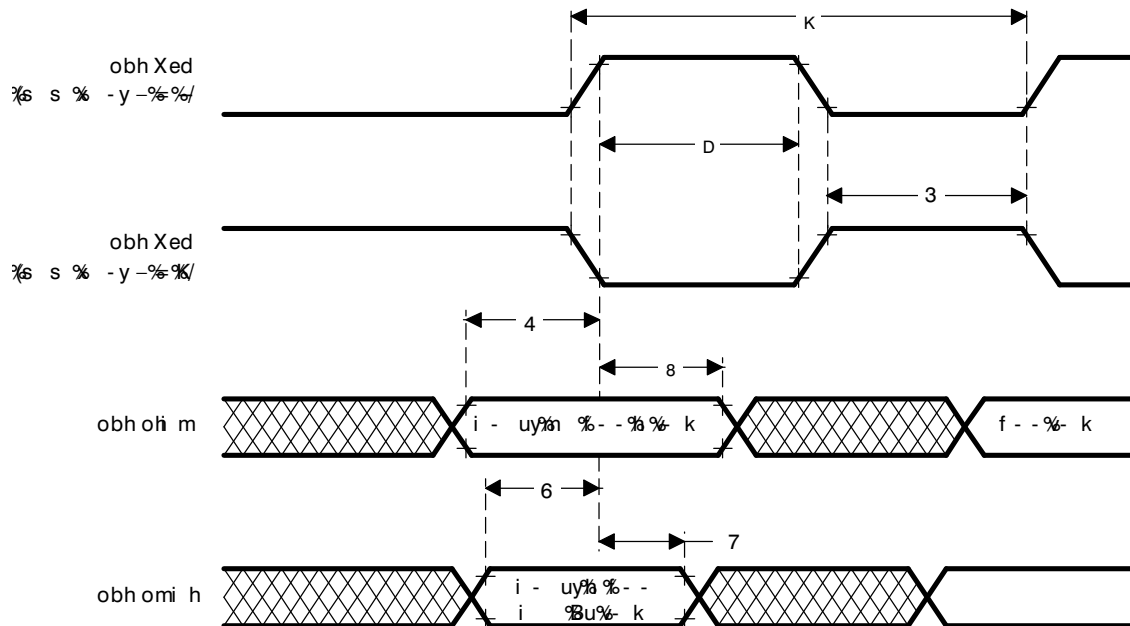

Figure 14. SPIn Master Mode External Timing (CLOCK PHASE = 1)

## SPI Slave Mode Timing Parameters

### SPI Slave Mode External Timing Parameters

(CLOCK PHASE = 0, SPInCLK = input, SPInSIMO = input, and SPInSOMI = output)<sup>(1)(2)(3)(4)</sup> (see Figure 15)

NO.			MIN	MAX	UNIT
1	$t_{c(SPC)S}$	Cycle time, SPInCLK <sup>(5)</sup>	100	$256t_{c(ICLK)}$	ns
2 <sup>(6)</sup>	$t_{w(SPCH)S}$	Pulse duration, SPInCLK high (clock polarity = 0)	$0.5t_{c(SPC)S} - 0.25t_{c(ICLK)}$	$0.5t_{c(SPC)S} + 0.25t_{c(ICLK)}$	ns
	$t_{w(SPCL)S}$	Pulse duration, SPInCLK low (clock polarity = 1)	$0.5t_{c(SPC)S} - 0.25t_{c(ICLK)}$	$0.5t_{c(SPC)S} + 0.25t_{c(ICLK)}$	
3 <sup>(6)</sup>	$t_{w(SPCL)S}$	Pulse duration, SPInCLK low (clock polarity = 0)	$0.5t_{c(SPC)S} - 0.25t_{c(ICLK)}$	$0.5t_{c(SPC)S} + 0.25t_{c(ICLK)}$	ns
	$t_{w(SPCH)S}$	Pulse duration, SPInCLK high (clock polarity = 1)	$0.5t_{c(SPC)S} - 0.25t_{c(ICLK)}$	$0.5t_{c(SPC)S} + 0.25t_{c(ICLK)}$	
4 <sup>(6)</sup>	$t_{d(SPCH-SOMI)S}$	Delay time, SPInCLK high to SPInSOMI valid (clock polarity = 0)		$6 + t_r$	ns
	$t_{d(SPCL-SOMI)S}$	Delay time, SPInCLK low to SPInSOMI valid (clock polarity = 1)		$6 + t_f$	
5 <sup>(6)</sup>	$t_{v(SPCH-SOMI)S}$	Valid time, SPInSOMI data valid after SPInCLK high (clock polarity = 0)	$t_{c(SPC)S} - 6 - t_r$		ns
	$t_{v(SPCL-SOMI)S}$	Valid time, SPInSOMI data valid after SPInCLK low (clock polarity = 1)	$t_{c(SPC)S} - 6 - t_f$		
6 <sup>(6)</sup>	$t_{su(SIMO-SPCL)S}$	Setup time, SPInSIMO before SPInCLK low (clock polarity = 0)	6		ns
	$t_{su(SIMO-SPCH)S}$	Setup time, SPInSIMO before SPInCLK high (clock polarity = 1)	6		
7 <sup>(6)</sup>	$t_{v(SPCL-SIMO)S}$	Valid time, SPInSIMO data valid after SPInCLK low (clock polarity = 0)	6		ns
	$t_{v(SPCH-SIMO)S}$	Valid time, SPInSIMO data valid after SPInCLK high (clock polarity = 1)	6		

- (1) The MASTER bit (SPInCTRL2.3) is cleared and the CLOCK PHASE bit (SPInCTRL2[0]) is cleared.
- (2) If the SPI is in slave mode, the following must be true:  $t_{c(SPC)S} \geq (PS + 1)t_{c(ICLK)}$ , where PS = prescale value set in SPInCTL1[12:5].
- (3) For rise and fall timings, see the "Switching Characteristics for Output Timings versus Load Capacitance" table.
- (4)  $t_{c(ICLK)} = \text{interface clock cycle time} = 1/f_{(ICLK)}$
- (5) When the SPIn is in slave mode, the following must be true:  
For PS values from 1 to 255:  $t_{c(SPC)S} \geq (PS + 1)t_{c(ICLK)} \geq 100$  ns, where PS is the prescale value set in the SPInCTL1[12:5] register bits.  
For PS values of 0:  $t_{c(SPC)S} = 2t_{c(ICLK)} \geq 100$  ns.
- (6) The active edge of the SPInCLK signal referenced is controlled by the CLOCK POLARITY bit (SPInCTRL2[1]).

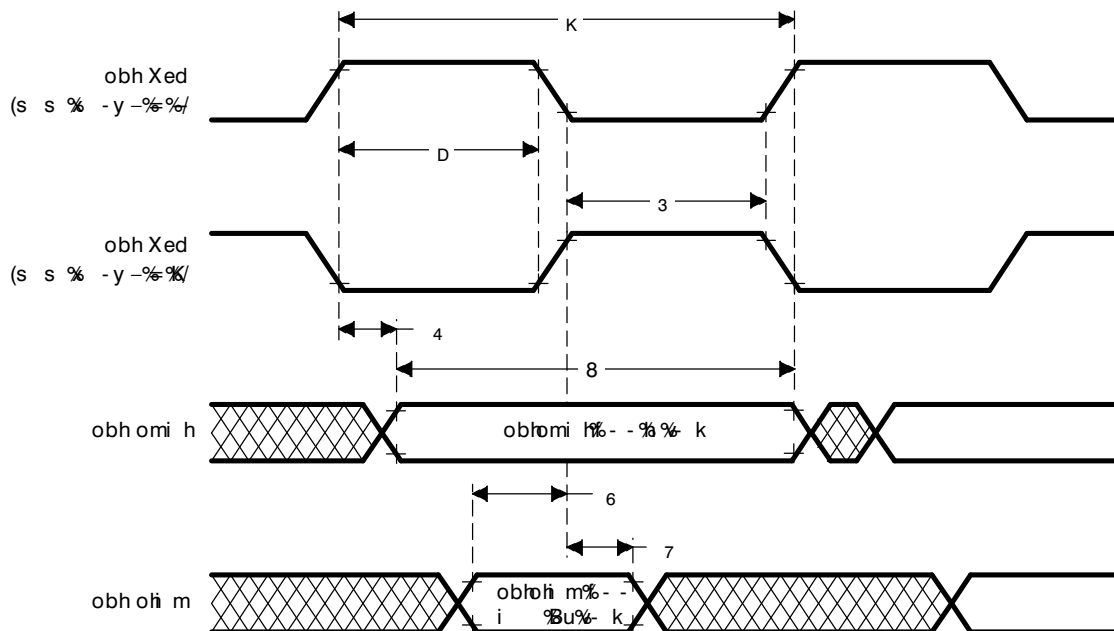

Figure 15. SPI Slave Mode External Timing (CLOCK PHASE = 0)

### SPIn Slave Mode External Timing Parameters

(CLOCK PHASE = 1, SPInCLK = input, SPInSIMO = input, and SPInSOMI = output)<sup>(1)(2)(3)(4)</sup> (see Figure 16)

NO.			MIN	MAX	UNIT
1	$t_{c(SPC)S}$	Cycle time, SPInCLK <sup>(5)</sup>	100	$256t_{c(ICLK)}$	ns
2 <sup>(6)</sup>	$t_{w(SPCH)S}$	Pulse duration, SPInCLK high (clock polarity = 0)	$0.5t_{c(SPC)S} - 0.25t_{c(ICLK)}$	$0.5t_{c(SPC)S} + 0.25t_{c(ICLK)}$	ns
	$t_{w(SPCL)S}$	Pulse duration, SPInCLK low (clock polarity = 1)	$0.5t_{c(SPC)S} - 0.25t_{c(ICLK)}$	$0.5t_{c(SPC)S} + 0.25t_{c(ICLK)}$	
3 <sup>(6)</sup>	$t_{w(SPCL)S}$	Pulse duration, SPInCLK low (clock polarity = 0)	$0.5t_{c(SPC)S} - 0.25t_{c(ICLK)}$	$0.5t_{c(SPC)S} + 0.25t_{c(ICLK)}$	ns
	$t_{w(SPCH)S}$	Pulse duration, SPInCLK high (clock polarity = 1)	$0.5t_{c(SPC)S} - 0.25t_{c(ICLK)}$	$0.5t_{c(SPC)S} + 0.25t_{c(ICLK)}$	
4 <sup>(6)</sup>	$t_{v(SOMI-SPCH)S}$	Valid time, SPInCLK high after SPInSOMI data valid (clock polarity = 0)	$0.5t_{c(SPC)S} - 6 - t_r$		ns
	$t_{v(SOMI-SPCL)S}$	Valid time, SPInCLK low after SPInSOMI data valid (clock polarity = 1)	$0.5t_{c(SPC)S} - 6 - t_f$		
5 <sup>(6)</sup>	$t_{v(SPCH-SOMI)S}$	Valid time, SPInSOMI data valid after SPInCLK high (clock polarity = 0)	$0.5t_{c(SPC)S} - 6 - t_r$		ns
	$t_{v(SPCL-SOMI)S}$	Valid time, SPInSOMI data valid after SPInCLK low (clock polarity = 1)	$0.5t_{c(SPC)S} - 6 - t_f$		
6 <sup>(6)</sup>	$t_{su(SIMO-SPCH)S}$	Setup time, SPInSIMO before SPInCLK high (clock polarity = 0)	6		ns
	$t_{su(SIMO-SPCL)S}$	Setup time, SPInSIMO before SPInCLK low (clock polarity = 1)	6		
7 <sup>(6)</sup>	$t_{v(SPCH-SIMO)S}$	Valid time, SPInSIMO data valid after SPInCLK high (clock polarity = 0)	6		ns
	$t_{v(SPCL-SIMO)S}$	Valid time, SPInSIMO data valid after SPInCLK low (clock polarity = 1)	6		

- (1) The MASTER bit (SPInCTRL2.3) is cleared and the CLOCK PHASE bit (SPInCTRL2[0]) is set.
- (2) If the SPI is in slave mode, the following must be true:  $t_{c(SPC)S} \geq (PS + 1) t_{c(ICLK)}$ , where PS = prescale value set in SPInCTL1[12:5].
- (3) For rise and fall timings, see the "Switching Characteristics for Output Timings versus Load Capacitance" table.
- (4)  $t_{c(ICLK)} = \text{interface clock cycle time} = 1 / f_{(ICLK)}$
- (5) When the SPIn is in slave mode, the following must be true:  
For PS values from 1 to 255:  $t_{c(SPC)S} \geq (PS + 1)t_{c(ICLK)} \geq 100$  ns, where PS is the prescale value set in the SPInCTL1[12:5] register bits.  
For PS values of 0:  $t_{c(SPC)S} = 2t_{c(ICLK)} \geq 100$  ns.
- (6) The active edge of the SPInCLK signal referenced is controlled by the CLOCK POLARITY bit (SPInCTRL2[1]).

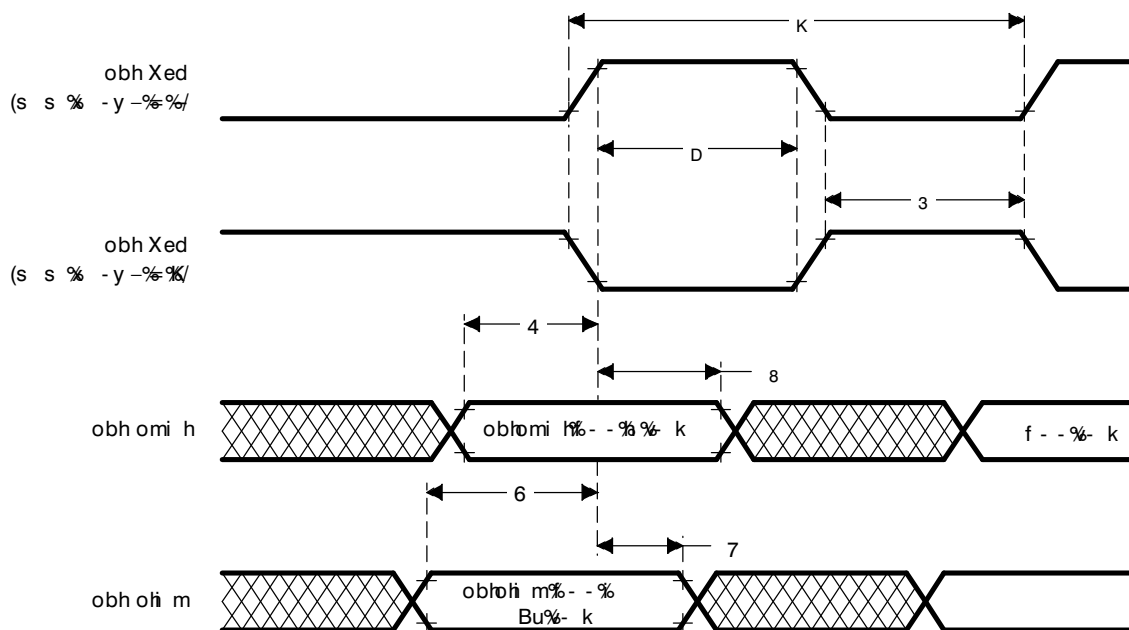

Figure 16. SPIn Slave Mode External Timing (CLOCK PHASE = 1)

SCI<sub>n</sub> ISOSYNCHRONOUS MODE TIMINGS INTERNAL CLOCK

Timing Requirements for Internal Clock SCI<sub>n</sub> Isosynchronous Mode<sup>(1)(2)(3)</sup>

(see Figure 18)

		(BAUD + 1) IS EVEN OR BAUD = 0		(BAUD + 1) IS ODD AND BAUD ≠ 0		UNIT
		MIN	MAX	MIN	MAX	
$t_{c(SCC)}$	Cycle time, SCI <sub>n</sub> CLK	$2t_{c(ICLK)}$	$2^{24} t_{c(ICLK)}$	$3t_{c(ICLK)}$	$(2^{24} - 1) t_{c(ICLK)}$	ns
$t_{w(SCCL)}$	Pulse duration, SCI <sub>n</sub> CLK low	$0.5t_{c(SCC)} - t_f$	$0.5t_{c(SCC)} + 5$	$0.5t_{c(SCC)} + 0.5t_{c(ICLK)} - t_f$	$0.5t_{c(SCC)} + 0.5t_{c(ICLK)}$	ns
$t_{w(SCCH)}$	Pulse duration, SCI <sub>n</sub> CLK high	$0.5t_{c(SCC)} - t_f$	$0.5t_{c(SCC)} + 5$	$0.5t_{c(SCC)} - 0.5t_{c(ICLK)} - t_f$	$0.5t_{c(SCC)} - 0.5t_{c(ICLK)}$	ns
$t_{d(SCCH-TXV)}$	Delay time, SCI <sub>n</sub> CLK high to SCI <sub>n</sub> TX valid		10		10	ns
$t_{v(TX)}$	Valid time, SCI <sub>n</sub> TX data after SCI <sub>n</sub> CLK low	$t_{c(SCC)} - 10$		$t_{c(SCC)} - 10$		ns
$t_{su(RX-SCCL)}$	Setup time, SCI <sub>n</sub> RX before SCI <sub>n</sub> CLK low	$t_{c(ICLK)} + t_f + 20$		$t_{c(ICLK)} + t_f + 20$		ns
$t_{v(SCCL-RX)}$	Valid time, SCI <sub>n</sub> RX data after SCI <sub>n</sub> CLK low	$-t_{c(ICLK)} + t_f + 20$		$-t_{c(ICLK)} + t_f + 20$		ns

- (1) BAUD = 24-bit concatenated value formed by the SCI[H,M,L]BAUD registers.
- (2)  $t_{c(ICLK)}$  = interface clock cycle time =  $1/f_{(ICLK)}$
- (3) For rise and fall timings, see the "Switching Characteristics for Output Timings versus Load Capacitance" table.

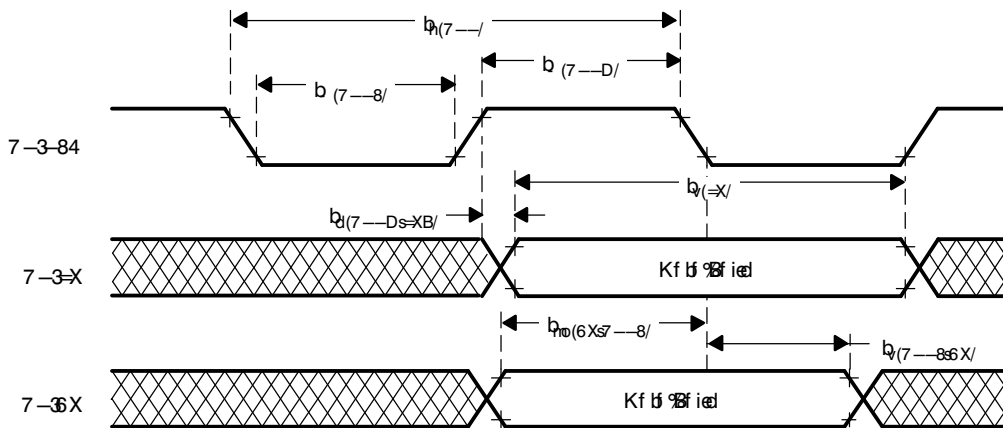

- A. Data transmission / reception characteristics for isosynchronous mode with external clocking are similar to the asynchronous mode. Data transmission occurs on the SCI<sub>n</sub>CLK rising edge, and data reception occurs on the SCI<sub>n</sub>CLK falling edge.

Figure 17. SCI<sub>n</sub> Isosynchronous Mode Timing Diagram for External Clock

## SCIn ISOSYNCHRONOUS MODE TIMINGS EXTERNAL CLOCK

### Timing Requirements for External Clock SCIn Isosynchronous Mode<sup>(1)(2)</sup>

(see Figure 17)

		MIN	MAX	UNIT
$t_{c(SCC)}$	Cycle time, SCInCLK <sup>(3)</sup>	$8t_{c(ICK)}$		ns
$t_{w(SCCH)}$	Pulse duration, SCInCLK high	$0.5t_{c(SCC)} - 0.25t_{c(ICK)}$	$0.5t_{c(SCC)} + 0.25t_{c(ICK)}$	ns
$t_{w(SCCL)}$	Pulse duration, SCInCLK low	$0.5t_{c(SCC)} - 0.25t_{c(ICK)}$	$0.5t_{c(SCC)} + 0.25t_{c(ICK)}$	ns
$t_{d(SCCH-TXV)}$	Delay time, SCInCLK high to SCInTX valid		$2t_{c(ICK)} + 12 + t_r$	ns
$t_{v(TX)}$	Valid time, SCInTX data after SCInCLK low	$2t_{c(SCC)} - 10$		ns
$t_{su(RX-SCCL)}$	Setup time, SCInRX before SCInCLK low	0		ns
$t_{v(SCCL-RX)}$	Valid time, SCInRX data after SCInCLK low	$2t_{c(ICK)} + 10$		ns

(1)  $t_{c(ICK)}$  = interface clock cycle time =  $1 / f_{(ICK)}$

(2) For rise and fall timings, see the "Switching Characteristics for Output Timings versus Load Capacitance" table.

(3) When driving an external SCInCLK, the following must be true:  $t_{c(SCC)} \geq 8t_{c(ICK)}$ .

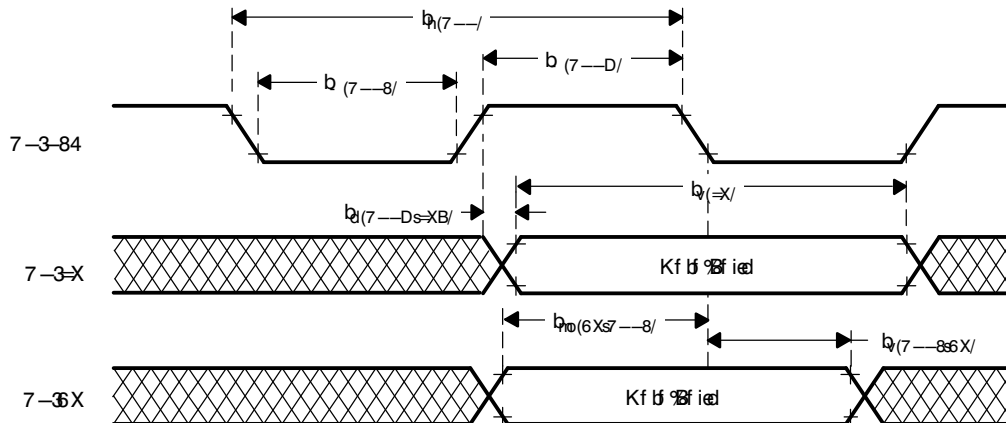

- A. Data transmission/reception characteristics for isosynchronous mode with internal clocking are similar to the asynchronous mode. Data transmission occurs on the SCInCLK rising edge, and data reception occurs on the SCInCLK falling edge.

Figure 18. SCIn Isosynchronous Mode Timing Diagram for Internal Clock

## I2C TIMING

Table 11 below assumes testing over recommended operating conditions.

Table 11. I2C Signals (SDA and SCL) Switching Characteristics<sup>(1)</sup>

PARAMETER		STANDARD MODE		FAST MODE		UNIT
		MIN	MAX	MIN	MAX	
$t_{c(I2CCLK)}$	Cycle time, I2C module clock	75	150	75	150	ns
$t_{c(SCL)}$	Cycle time, SCL	10		2.5		$\mu$ s
$t_{su(SCLH-SDAL)}$	Setup time, SCL high before SDA low (for a repeated START condition)	4.7		0.6		$\mu$ s
$t_{h(SCLL-SDAL)}$	Hold time, SCL low after SDA low (for a repeated START condition)	4		0.6		$\mu$ s
$t_{w(SCLL)}$	Pulse duration, SCL low	4.7		1.3		$\mu$ s
$t_{w(SCLH)}$	Pulse duration, SCL high	4		0.6		$\mu$ s
$t_{su(SDA-SCLH)}$	Setup time, SDA valid before SCL high	250		100		ns
$t_{h(SDA-SCLL)}$	Hold time, SDA valid after SCL low	0	3.45 <sup>(2)</sup>	0	0.9	$\mu$ s
$t_{w(SDAH)}$	Pulse duration, SDA high between STOP and START conditions	4.7		1.3		$\mu$ s
$t_{su(SCLH-SDAH)}$	Setup time, SCL high before SDA high (for STOP condition)	4.0		0.6		$\mu$ s
$t_{w(SP)}$	Pulse duration, spike (must be suppressed)			0	50	ns
$C_b^{(3)}$	Capacitive load for each bus line		400		400	pF

- (1) The I2C pins SDA and SCL do not feature fail-safe I/O buffers. These pins could potentially draw current when the device is powered down.
- (2) The maximum  $t_{h(SDA-SCLL)}$  for I2C bus devices needs only be met if the device does not stretch the low period ( $t_{w(SCLL)}$ ) of the SCL signal.
- (3)  $C_b$  = The total capacitance of one bus line in pF.

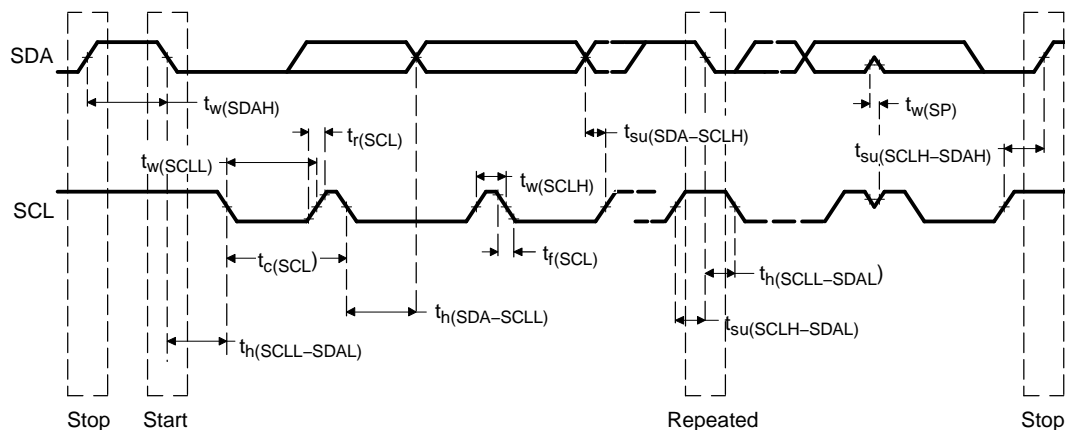

- A. A device must internally provide a hold time of at least 300 ns for the SDA signal (referred to the  $V_{IHmin}$  of the SCL signal) to bridge the undefined region of the falling edge of SCL.
- B. The maximum  $t_{h(SDA-SCLL)}$  needs only be met if the device does not stretch the LOW period ( $t_{w(SCLL)}$ ) of the SCL signal.
- C. A fast-mode I2C-bus device can be used in a standard-mode I2C-bus system, but the requirement  $t_{su(SDA-SCLH)} \geq 250$  ns must then be met. This will automatically be the case if the device does not stretch the LOW period of the SCL signal. If such a device does stretch the LOW period of the SCL signal, it must output the next data bit to the SDA line  $t_r \max + t_{su(SDA-SCLH)}$ .
- D.  $C_b$  = total capacitance of one bus line in pF. If mixed with HS-mode devices, faster fall-times are allowed.

Figure 19. I2C Timings

## STANDARD CAN CONTROLLER (SCC) MODE TIMINGS

### Dynamic Characteristics for the CANSTX and CANSRX Pins

PARAMETER		MIN	MAX	UNIT
$t_{d(CANSTX)}$	Delay time, transmit shift register to CANSTX pin <sup>(1)</sup>		15	ns
$t_{d(CANSRX)}$	Delay time, CANSRX pin to receive shift register		5	ns

(1) These values do not include the rise/fall times of the output buffer.

EXPANSION BUS MODULE TIMING

Expansion Bus Timing Parameters,  $-40^{\circ}\text{C} \leq T_J \leq 150^{\circ}\text{C}$ ,  $3.0\text{ V} \leq V_{CC} \leq 3.6\text{ V}$

(see Figure 20 and Figure 21)

		MIN	MAX	UNIT
$t_{c(\text{CO})}$	Cycle time, CLKOUT	20.8		ns
$t_{d(\text{COH-EBADV})}$	Delay time, CLKOUT high to EBADDR valid		21.4	ns
$t_{h(\text{COH-EBADIV})}$	Hold time, EBADDR invalid after CLKOUT high		12.4	ns
$t_{d(\text{COH-EBOE})}$	Delay time, CLKOUT high to $\overline{\text{EBOE}}$ fall		11.4	ns
$t_{h(\text{COH-EBOEH})}$	Hold time, $\overline{\text{EBOE}}$ rise after CLKOUT high		11.4	ns
$t_{d(\text{COL-EBWR})}$	Delay time, CLKOUT low to write strobe ( $\overline{\text{EBWR}}$ ) low		11.3	ns
$t_{h(\text{COL-EBWRH})}$	Hold time, $\overline{\text{EBWR}}$ high after CLKOUT low		11.6	ns
$t_{su(\text{EBRDATV-COH})}$	Setup time, EBDATA valid before CLKOUT high (READ) <sup>(1)</sup>	15.2		ns
$t_{h(\text{COH-EBRDATIV})}$	Hold time, EBDATA invalid after CLKOUT high (READ)		(-14.7)	ns
$t_{d(\text{COL-EBWDATV})}$	Delay time, CLKOUT low to EBDATA valid (WRITE) <sup>(2)</sup>		16.1	ns
$t_{h(\text{COL-EBWDATIV})}$	Hold time, EBDATA invalid after CLKOUT low (WRITE)		14.7	ns
<b>SECONDARY TIMES</b>				
$t_{d(\text{COH-EBCS0})}$	Delay, CLKOUT high to $\overline{\text{EBCS0}}$ fall		13.6	ns
$t_{h(\text{COH-EBCS0H})}$	Hold, $\overline{\text{EBCS0}}$ rise after CLKOUT high		13.2	ns
$t_{su(\text{COH-EBHOLDL})}$	Setup time, $\overline{\text{EBHOLD}}$ low to CLKOUT high <sup>(1)</sup>	10.9		ns
$t_{su(\text{COH-EBHOLDH})}$	Setup time, $\overline{\text{EBHOLD}}$ high to CLKOUT high <sup>(1)</sup>	10.5		ns

- (1) Setup time is the minimum time under worst case conditions. Data with less setup time will not work.
- (2) Valid after CLKOUT goes low for write cycles.

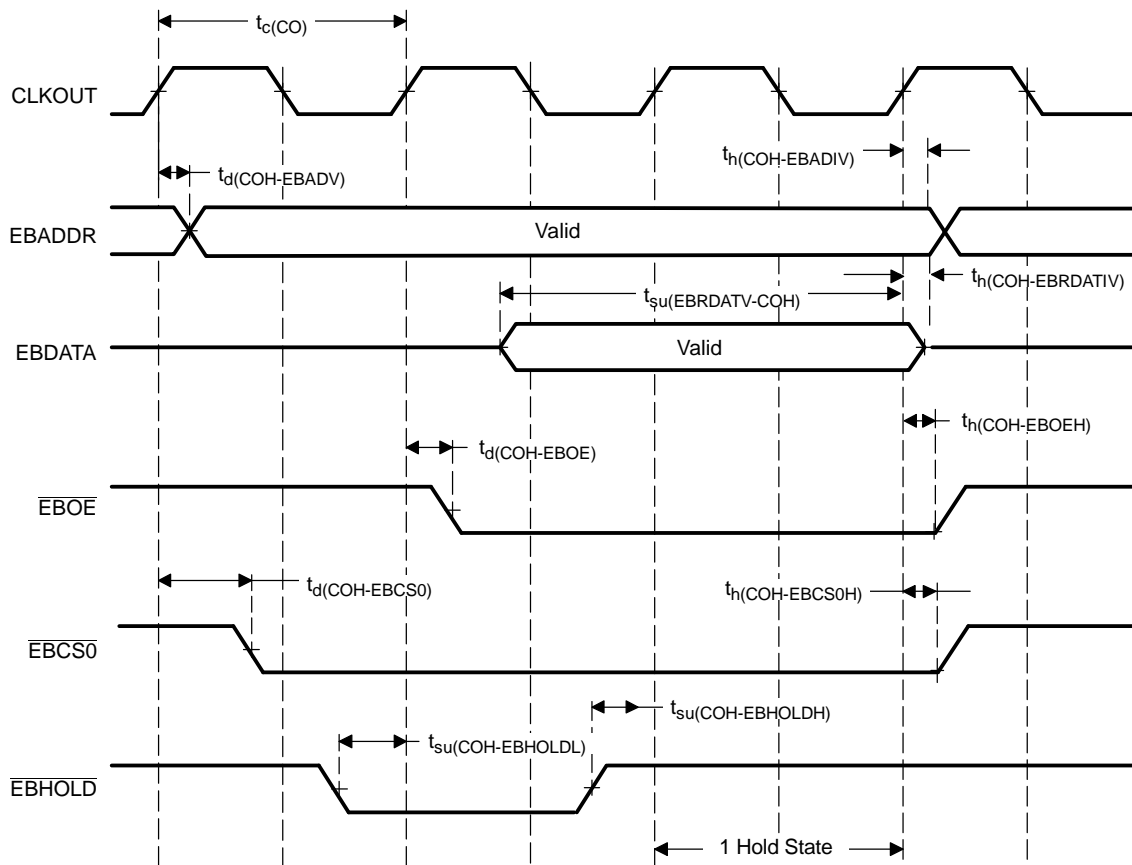
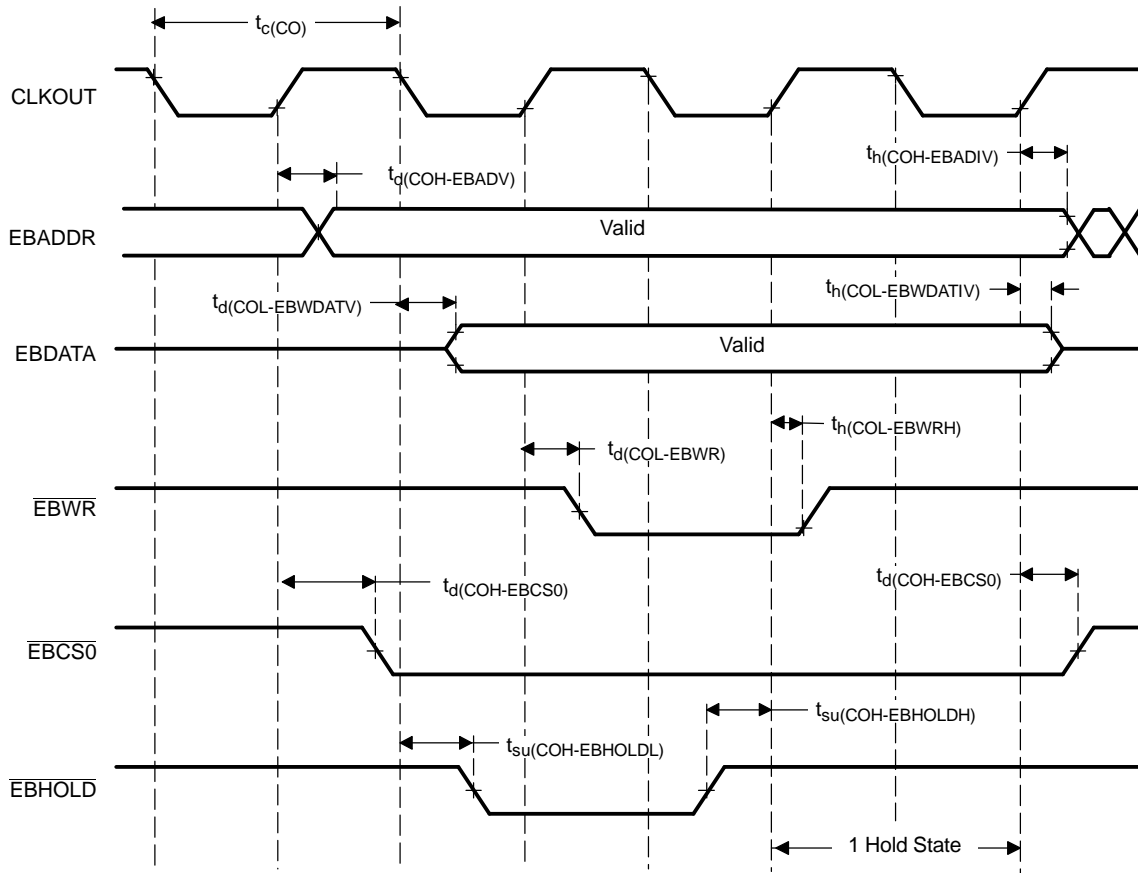

Figure 20. Expansion Memory Signal Timing - Reads





**Figure 21. Expansion Memory Signal Timing - Writes**

---

## HIGH-END TIMER (HET) TIMINGS

### Minimum PWM Output Pulse Width:

This is equal to one high resolution clock period (HRP). The HRP is defined by the 6-bit high resolution prescale factor (hr), which is user defined, giving prescale factors of 1 to 64, with a linear increment of codes.

Therefore, the minimum PWM output pulse width =  $HRP(\min) = hr(\min)/SYSCLK = 1/SYSCLK$

For example, for a SYSCLK of 30 MHz, the minimum PWM output pulse width =  $1/30 = 33.33\text{ns}$

### Minimum Input Pulses that Can Be Captured:

The input pulse width must be greater or equal to the low resolution clock period (LRP), i.e., the HET loop (the HET program must fit within the LRP). The LRP is defined by the 3-bit loop-resolution prescale factor (lr), which is user defined, with a power of 2 increment of codes. That is, the value of lr can be 1, 2, 4, 8, 16, or 32.

Therefore, the minimum input pulse width =  $LRP(\min) = hr(\min) * lr(\min)/SYSCLK = 1 * 1/SYSCLK$

For example, with a SYSCLK of 30 MHz, the minimum input pulse width =  $1 * 1/30 = 33.33 \text{ ns}$

### NOTE:

Once the input pulse width is greater than LRP, the resolution of the measurement is still HRP. (That is, the captured value gives the number of HRP clocks inside the pulse.)

Abbreviations:

hr = HET high resolution divide rate = 1, 2, 3,...63, 64

lr = HET low resolution divide rate = 1, 2, 4, 8, 16, 32

High resolution clock period = HRP =  $hr/SYSCLK$

Loop resolution clock period = LRP =  $hr*lr/SYSCLK$

### MULTI-BUFFERED A-TO-D CONVERTER (MibADC)

The multi-buffered A-to-D converter (MibADC) has a separate power bus for its analog circuitry that enhances the A-to-D performance by preventing digital switching noise on the logic circuitry, which could be present on  $V_{SS}$  and  $V_{CC}$ , from coupling into the A-to-D analog stage. All A-to-D specifications are given with respect to  $AD_{REFLO}$  unless otherwise noted.

Resolution	10 bits (1024 values)
Monotonic	Assured
Output conversion code	00h to 3FFh [00 for $V_{AI} \leq AD_{REFLO}$ ; 3FF for $V_{AI} \geq AD_{REFHI}$ ]

**Table 12. MibADC Recommended Operating Conditions<sup>(1)</sup>**

		MIN	MAX	UNIT
$AD_{REFHI}$	A-to-D high-voltage reference source	$V_{SSAD}$	$V_{CCAD}$	V
$AD_{REFLO}$	A-to-D low-voltage reference source	$V_{SSAD}$	$V_{CCAD}$	V
$V_{AI}$	Analog input voltage	$V_{SSAD} - 0.3$	$V_{CCAD} + 0.3$	V
$I_{AIC}$	Analog input clamp current <sup>(2)</sup> ( $V_{AI} < V_{SSAD} - 0.3$ or $V_{AI} > V_{CCAD} + 0.3$ )	-2	2	mA

- (1) For  $V_{CCAD}$  and  $V_{SSAD}$  recommended operating conditions, see the "Device Recommended Operating Conditions" table.  
(2) Input currents into any ADC input channel outside the specified limits could affect conversion results of other channels.

**Table 13. Operating Characteristics Over Full Ranges of Recommended Operating Conditions<sup>(1)(2)</sup>**

PARAMETER	DESCRIPTION/CONDITIONS	MIN	TYP	MAX	UNIT	
$R_i$	Analog input resistance		250	500	$\Omega$	
$C_i$	Analog input capacitance	See Figure 22.	Conversion		10	pF
			Sampling		30	pF
$I_{AIL}$	Analog input leakage current	See Figure 22.	-1	1	$\mu$ A	
$I_{ADREFHI}$	$AD_{REFHI}$ input current	$AD_{REFHI} = 3.6$ V, $AD_{REFLO} = V_{SSAD}$		5	mA	
CR	Conversion range over which specified accuracy is maintained	$AD_{REFHI} - AD_{REFLO}$		3	3.6	V
$E_{DNL}$	Differential nonlinearity error	Difference between the actual step width and the ideal value. See Figure 23.		$\pm 2$	LSB	
$E_{INL}$	Integral nonlinearity error	Maximum deviation from the best straight line through the MibADC. MibADC transfer characteristics, excluding the quantization error. See Figure 24.		$\pm 2$	LSB	
$E_{TOT}$	Total error/absolute accuracy	Maximum value of the difference between an analog value and the ideal midstep value. See Figure 25.		$\pm 2$	LSB	

- (1)  $V_{CCAD} = AD_{REFHI}$   
(2)  $1 \text{ LSB} = (AD_{REFHI} - AD_{REFLO}) / 2^{10}$  for the MibADC

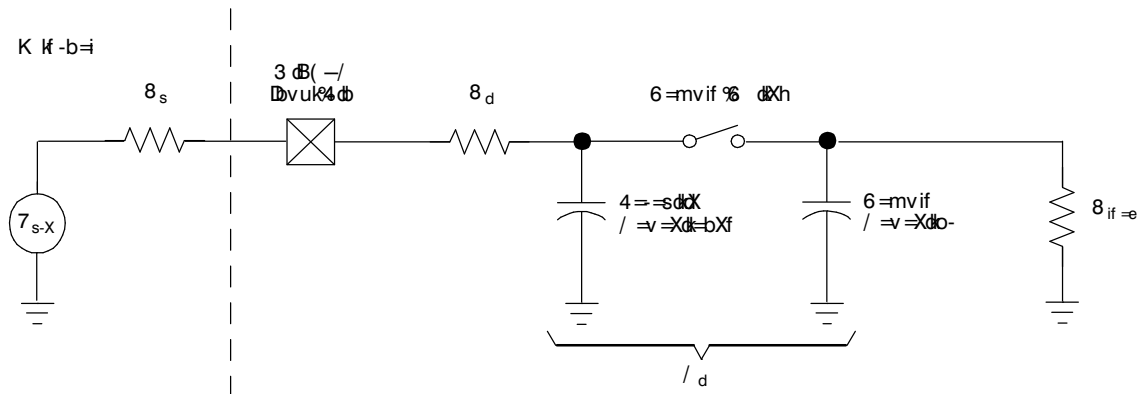

Figure 22. MibADC Input Equivalent Circuit

### Multi-Buffer ADC Timing Requirements

		MIN	NOM	MAX	UNIT
$t_{c(ADCLK)}$	Cycle time, MibADC clock	0.05			$\mu\text{s}$
$t_{d(SH)}$	Delay time, sample and hold time	1			$\mu\text{s}$
$t_{d(C)}$	Delay time, conversion time	0.55			$\mu\text{s}$
$t_{d(SHC)}^{(1)}$	Delay time, total sample/hold and conversion time	1.55			$\mu\text{s}$

(1) This is the minimum sample/hold and conversion time that can be achieved. These parameters are dependent on many factors; for more details, see the *TMS470R1x Multi-Buffered Analog-to-Digital Converter (MibADC) Reference Guide* (literature number SPNU206).

The differential nonlinearity error shown in Figure 23 (sometimes referred to as differential linearity) is the difference between an actual step width and the ideal value of 1 LSB.

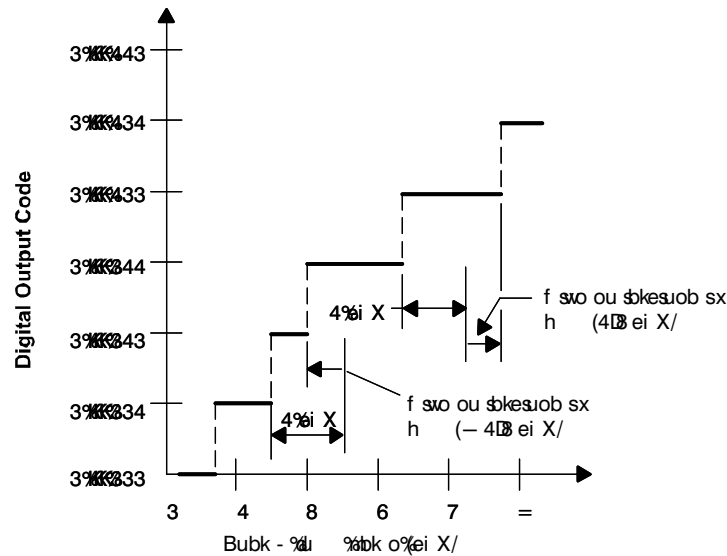

A.  $1 \text{ LSB} = (AD_{REFHI} - AD_{REFLO})/2^{10}$

Figure 23. Differential Nonlinearity (DNL)

The integral nonlinearity error shown in Figure 24 (sometimes referred to as linearity error) is the deviation of the values on the actual transfer function from a straight line.

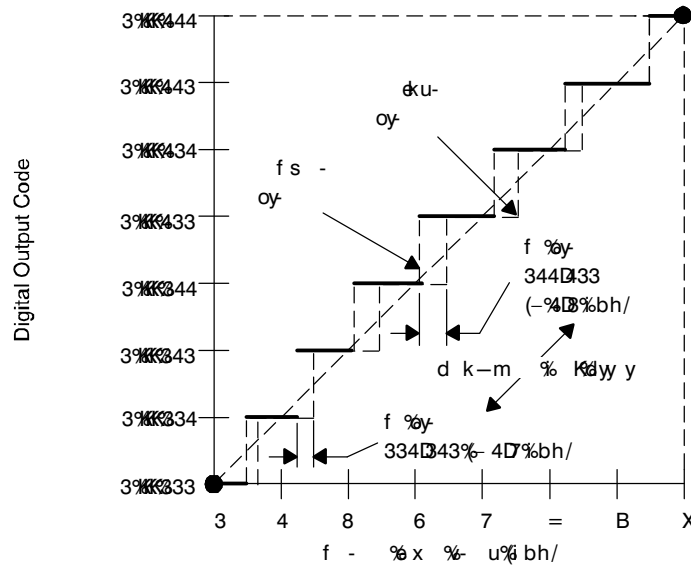

A.  $1 \text{ LSB} = (AD_{REFHI} - AD_{REFLO})/2^{10}$

Figure 24. Integral Nonlinearity (INL) Error

The absolute accuracy or total error of an MibADC as shown in Figure 25 is the maximum value of the difference between an analog value and the ideal midstep value.

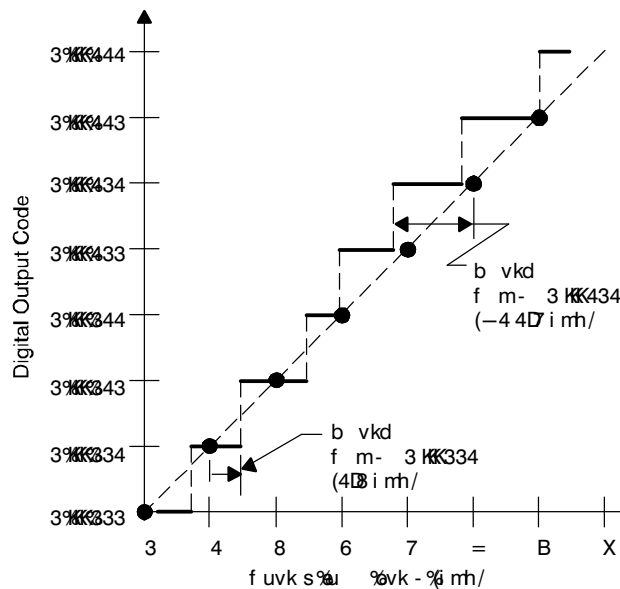

A.  $1 \text{ LSB} = (AD_{REFHI} - AD_{REFLO})/2^{10}$

Figure 25. Absolute Accuracy (Total) Error

---

**PGE Thermal Resistance Characteristics**

PARAMETER	°C/W
$R_{\theta JA}$	43
$R_{\theta JC}$	5

**PZ Thermal Resistance Characteristics**

PARAMETER	°C/W
$R_{\theta JA}$	48
$R_{\theta JC}$	5

PZ (S-PQFP-G100)

PLASTIC QUAD FLATPACK

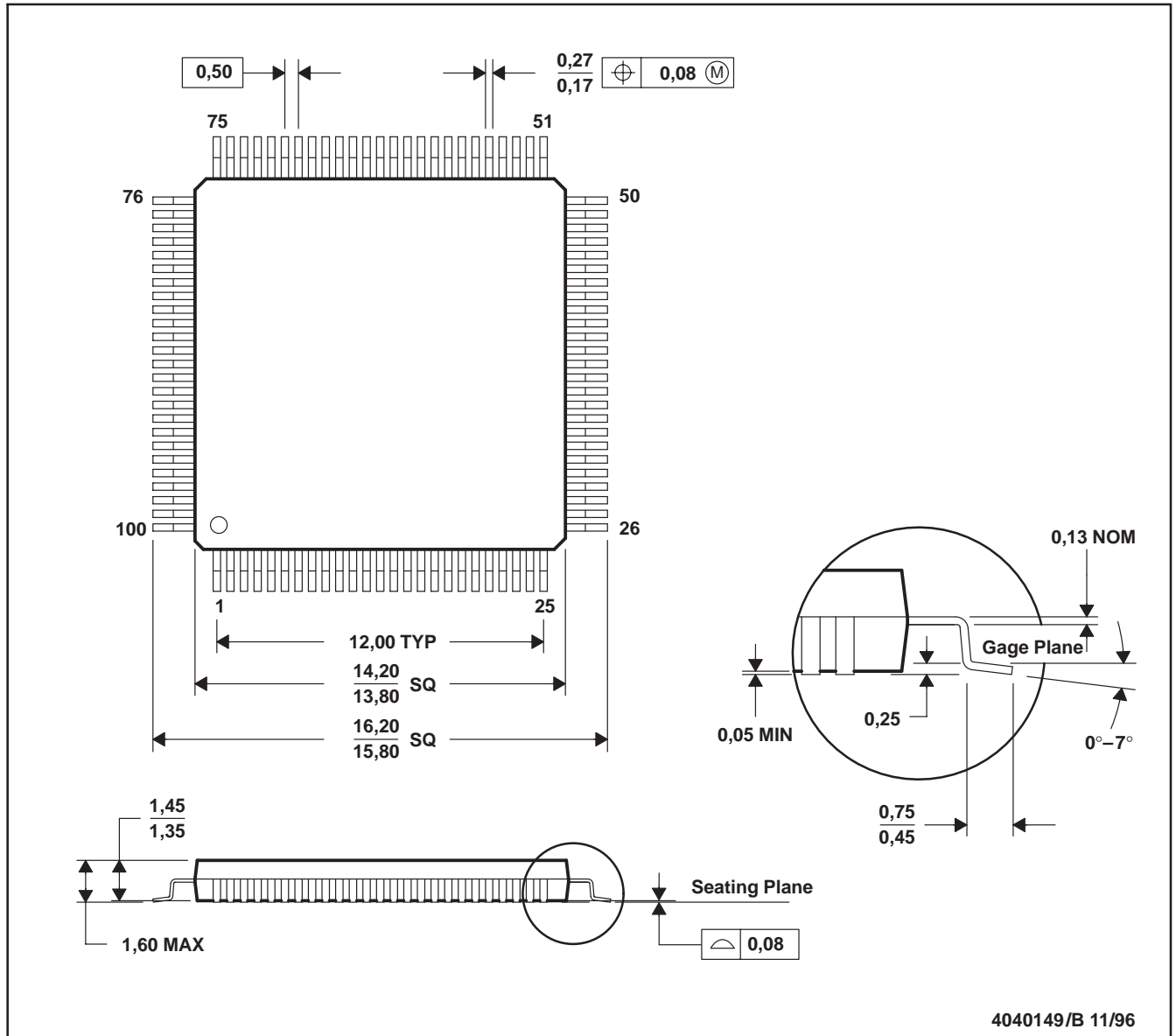

4040149/B 11/96

- NOTES: A. All linear dimensions are in millimeters.  
 B. This drawing is subject to change without notice.  
 C. Falls within JEDEC MS-026

PGE (S-PQFP-G144)

PLASTIC QUAD FLATPACK

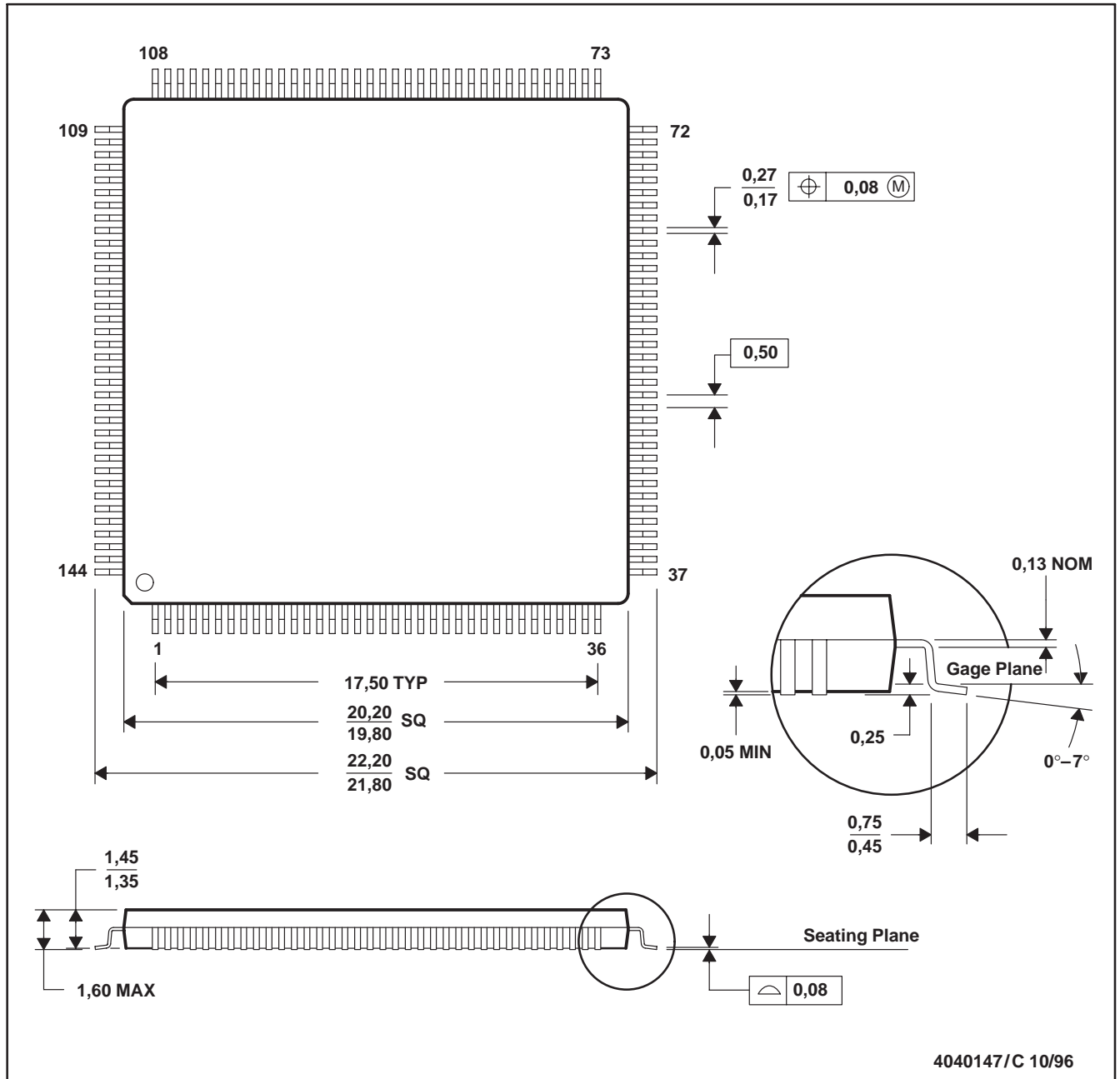

- NOTES: A. All linear dimensions are in millimeters.  
 B. This drawing is subject to change without notice.  
 C. Falls within JEDEC MS-026



## IMPORTANT NOTICE

Texas Instruments Incorporated and its subsidiaries (TI) reserve the right to make corrections, modifications, enhancements, improvements, and other changes to its products and services at any time and to discontinue any product or service without notice. Customers should obtain the latest relevant information before placing orders and should verify that such information is current and complete. All products are sold subject to TI's terms and conditions of sale supplied at the time of order acknowledgment.

TI warrants performance of its hardware products to the specifications applicable at the time of sale in accordance with TI's standard warranty. Testing and other quality control techniques are used to the extent TI deems necessary to support this warranty. Except where mandated by government requirements, testing of all parameters of each product is not necessarily performed.

TI assumes no liability for applications assistance or customer product design. Customers are responsible for their products and applications using TI components. To minimize the risks associated with customer products and applications, customers should provide adequate design and operating safeguards.

TI does not warrant or represent that any license, either express or implied, is granted under any TI patent right, copyright, mask work right, or other TI intellectual property right relating to any combination, machine, or process in which TI products or services are used. Information published by TI regarding third-party products or services does not constitute a license from TI to use such products or services or a warranty or endorsement thereof. Use of such information may require a license from a third party under the patents or other intellectual property of the third party, or a license from TI under the patents or other intellectual property of TI.

Reproduction of information in TI data books or data sheets is permissible only if reproduction is without alteration and is accompanied by all associated warranties, conditions, limitations, and notices. Reproduction of this information with alteration is an unfair and deceptive business practice. TI is not responsible or liable for such altered documentation.

Resale of TI products or services with statements different from or beyond the parameters stated by TI for that product or service voids all express and any implied warranties for the associated TI product or service and is an unfair and deceptive business practice. TI is not responsible or liable for any such statements.

Following are URLs where you can obtain information on other Texas Instruments products and application solutions:

<b>Products</b>		<b>Applications</b>	
Amplifiers	<a href="http://amplifier.ti.com">amplifier.ti.com</a>	Audio	<a href="http://www.ti.com/audio">www.ti.com/audio</a>
Data Converters	<a href="http://dataconverter.ti.com">dataconverter.ti.com</a>	Automotive	<a href="http://www.ti.com/automotive">www.ti.com/automotive</a>
DSP	<a href="http://dsp.ti.com">dsp.ti.com</a>	Broadband	<a href="http://www.ti.com/broadband">www.ti.com/broadband</a>
Interface	<a href="http://interface.ti.com">interface.ti.com</a>	Digital Control	<a href="http://www.ti.com/digitalcontrol">www.ti.com/digitalcontrol</a>
Logic	<a href="http://logic.ti.com">logic.ti.com</a>	Military	<a href="http://www.ti.com/military">www.ti.com/military</a>
Power Mgmt	<a href="http://power.ti.com">power.ti.com</a>	Optical Networking	<a href="http://www.ti.com/opticalnetwork">www.ti.com/opticalnetwork</a>
Microcontrollers	<a href="http://microcontroller.ti.com">microcontroller.ti.com</a>	Security	<a href="http://www.ti.com/security">www.ti.com/security</a>
		Telephony	<a href="http://www.ti.com/telephony">www.ti.com/telephony</a>
		Video & Imaging	<a href="http://www.ti.com/video">www.ti.com/video</a>
		Wireless	<a href="http://www.ti.com/wireless">www.ti.com/wireless</a>

Mailing Address: Texas Instruments  
Post Office Box 655303 Dallas, Texas 75265

Copyright © Each Manufacturing Company.

All Datasheets cannot be modified without permission.

This datasheet has been download from :

[www.AllDataSheet.com](http://www.AllDataSheet.com)

100% Free DataSheet Search Site.

Free Download.

No Register.

Fast Search System.

[www.AllDataSheet.com](http://www.AllDataSheet.com)