

# Three Phase Power / Energy IC with SPI Interface



sames

## SA9904B

### FEATURES

- Bi-directional active and reactive power/energy measurement
- RMS Voltage and frequency measurement
- Individual Phase information
- SPI communication bus
- Meets the IEC 61036 Specification requirements for Class 1 AC Watt hour meters
- Meets the IEC 61268 Specification requirements for Class 2 VAR hour meters
- Protected against ESD
- Total power consumption rating below 60mW
- Uses current transformers for current sensing
- Operates over a wide temperature range
- Precision on-chip voltage reference

### DESCRIPTION

The SAMES SA9904B is a three phase bi-directional energy/power metering integrated circuit that has been designed to measure active and reactive energy, RMS mains voltage and frequency. The SA9904B has an integrated SPI serial interface for communication with a micro-controller. Measured values for active and reactive energy, the mains voltage and frequency for each phase are accessible through the SPI interface from 24 bit registers. The SA9904B active and reactive energy registers are capable of holding at least 52 seconds of accumulated energy at full load. A mains voltage zero crossover is available on the F50 output.

The SA9904B includes all the required functions for three-phase power and energy measurement such as oversampling A/D converters for the voltage and current sense inputs, power calculation and energy integration. This innovative universal three phase power/energy metering integrated circuit is ideally suited for energy calculations in applications such as electricity dispensing systems, residential metering and factory energy metering and control.

The SA9904B integrated circuit is available in 20 pin dual-in-line plastic (PDIP20), as well as 20 pin small outline (SOIC20) package types.

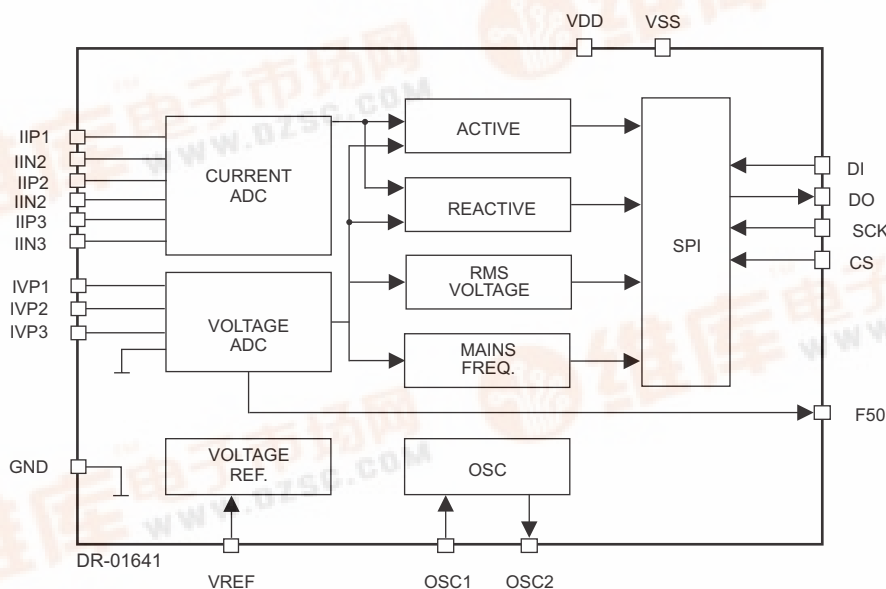

Figure 1: Block diagram

**ELECTRICAL CHARACTERISTICS**(V<sub>DD</sub> = 2.5V, V<sub>SS</sub> = -2.5V, over the temperature range -10°C to +70°C<sup>#</sup>, unless otherwise specified.)

Parameter	Symbol	Min	Typ	Max	Unit	Condition
Operating temp. Range	T <sub>O</sub>	-25		+85	°C	
Supply Voltage: Positive	V <sub>DD</sub>	2.25		2.75	V	
Supply Voltage: Negative	V <sub>SS</sub>	-2.75		-2.25	V	
Supply Current: Positive	I <sub>DD</sub>		9.5	11	mA	
Supply Current: Negative	I <sub>SS</sub>		9.5	11	mA	
<b>Current Sensor Inputs (Differential)</b>						
Input Current Range	I <sub>II</sub>	-25		+25	µA	Peak value
<b>Voltage Sensor Input (Asymmetrical)</b>						
Input Current Range	I <sub>IV</sub>	-25		+25	µA	Peak value
Pins SCK High Voltage Low Voltage	V <sub>IH</sub> V <sub>IL</sub>	V <sub>DD</sub> -1		V <sub>SS</sub> +1	V V	
	f <sub>SCK</sub> t <sub>LO</sub> t <sub>HI</sub>			800	kHz µs µs	
Pins CS, DI High Voltage Low Voltage	V <sub>IH</sub> V <sub>IL</sub>	V <sub>DD</sub> -1		V <sub>SS</sub> +1	V V	
Pins F50, DO Low Voltage High Voltage	V <sub>OL</sub> V <sub>OH</sub>	V <sub>DD</sub> -1		V <sub>SS</sub> +1	V V	I <sub>OL</sub> = 5mA I <sub>OH</sub> = -2mA
Oscillator	Recommended crystal: TV colour burst crystal f = 3.5795 MHz					
Pin VREF Ref. Current Ref. Voltage	-I <sub>R</sub> V <sub>R</sub>	23 1.1	25	27 1.3	µA V	With R = 47kΩ connected to V <sub>SS</sub> Reference to V <sub>SS</sub>

**ABSOLUTE MAXIMUM RATINGS\***

Parameter	Symbol	Min	Max	Unit
Supply Voltage	V <sub>DD</sub> -V <sub>SS</sub>	3.6V	6.0	V
Current on any pin	I <sub>PIN</sub>	-150	+150	mA
Storage Temperature	T <sub>STG</sub>	-40	+125	°C
Operating Temperature	T <sub>O</sub>	-40	+85	°C

\*Stresses above those listed under "Absolute Maximum Ratings" may cause permanent damage to the device. This is a stress rating only. Functional operation of the device at these or any other condition above those indicated in the operational sections of this specification, is not implied. Exposure to Absolute Maximum Ratings for extended periods may affect device reliability.

During manufacturing, testing and shipment we take great care to protect our products against potential external environmental damage such as Electrostatic Discharge (ESD). Although our products have ESD protection circuitry, permanent damage may occur on products subjected to high-energy electrostatic discharges accumulated on the human body and test equipment and can discharge without detection. Therefore, proper ESD precautions are recommended to avoid performance degradation or loss of functionality during product handling.



**PIN DESCRIPTION**

PIN	Designation	Description
16	GND	Analog Ground. The supply voltage to this pin should be mid-way between V <sub>DD</sub> and V <sub>SS</sub> .
6	V <sub>DD</sub>	Positive Supply voltage. The voltage to this pin is typically +2.5V if a shunt resistor is used for current sensing or in the case of a current transformer a +5V supply can be applied.
14	V <sub>SS</sub>	Negative Supply Voltage. The voltage to this pin is typically -2.5V if a shunt resistor is used for current sensing or in the case of a current transformer a 0V supply can be applied.
17, 20, 3	IVP1, IVP2, IVP3	Analog Input for Voltage Phase 1, Phase 2 and Phase 3. The current into the A/D converter should be set at 14μ <sub>ARMS</sub> at nominal mains voltage. The voltage sense input saturates at an input current of ±25μA peak.
18, 19, 1, 2, 4, 5	IIP1, IIN1, IIP2, IIN2, IIP3, IIN3	Inputs for current sensors. The shunt resistor voltage from each channel is converted to a current of 16μ <sub>ARMS</sub> at rated conditions. The current sense input saturates at an input current of ±25μA peak.
15	VREF	This pin provides the connection for the reference current setting resistor. A 47kΩ resistor connected to sets the optimum operating condition.
10, 11	OSC1, OSC2	Connections for a crystal or ceramic resonator. (OSC1 = input; OSC2 = Output)
8	SCK	Serial clock in. This pin is used to strobe data in and out of the SA9904B
9	DO	Serial data out. Data from the SA9904B is strobed out on this pin. DO is only driven when CS is active.
7	F50	Voltage zero crossover. The F50 output generates a pulse, on every rising edge of the mains voltage for any one phase.
12	DI	Serial data in. Data is only accepted during an active chip select (CS).
13	CS	Chip select. The CS pin is active high.

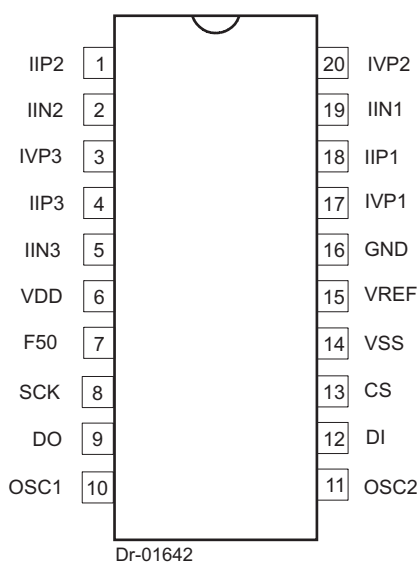
**ORDERING INFORMATION**

Part Number	Package
SA9904BPA	PDIP20
SA9904BSA	SOIC20

Figure 2: Pin connections: Package: PDIP20, SOIC20



## SA9904B

sames

### FUNCTIONAL DESCRIPTION

The SA9904B is a CMOS mixed signal Analog/Digital integrated circuit, which performs the measurement of active power, reactive power, RMS voltage and mains frequency. The integrated circuit includes all the required functions for three-phase power and energy measurement such as oversampling A/D converters for the voltage and current sense inputs, power calculation and energy integration.

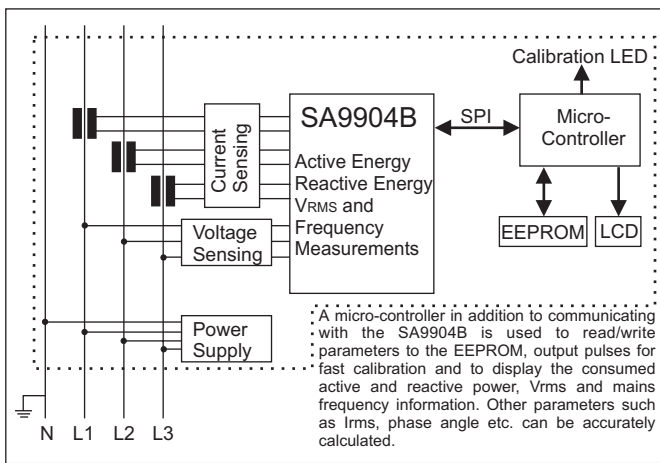

Dr-01643

Figure 3: Typical architecture of an energy meter using the SA9904B

The SA9904B integrates instantaneous active and reactive power into 24 bit registers. RMS voltage and frequency are continuously measured and stored in the respective registers. The mains voltage zero crossover is available on the F50 output. The SPI interface of the SA9904B has a tri-state output that allows connection of more than one metering device on a single SPI bus.

### INPUT SIGNALS

#### Analog Input Configuration

The input circuitry of the current and voltage sensor inputs is illustrated in figure 4. These inputs are protected against electrostatic discharge through clamping diodes. The feedback loops from the outputs of the amplifiers  $A_I$  and  $A_V$  generate virtual shorts on the signal inputs. Exact duplications of the input currents are generated for the analog signal processing circuitry. The current and voltage sense inputs are identical. Both inputs are differential current driven up to  $\pm 25\mu\text{A}$  peak. One of the voltage sense amplifier input terminals is internally connected to GND. This is possible because the voltage sense input is much less sensitive to externally induced parasitic signals compared to the current sense inputs.

#### Current Sense Inputs (IIN1, IIP1, IIN2, IIP2, IIN3, IIP3)

At rated current ( $I_{MAX}$ ) the resistor values should be selected for input currents of  $16\mu\text{A}_{RMS}$ . Referring to figure 5, the resistors R1

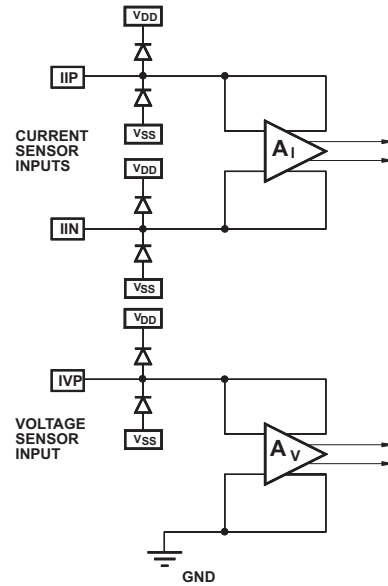

DR-01288

Figure 4: Analog input internal configuration

and R2 on current channel 1, resistors R3 and R4 on current channel 2 and resistors R5 and R6 on current channel 3, define the current levels into the SA9904B current sense inputs. The current sense inputs saturates at  $\pm 25\mu\text{A}$  peak. Resistors Rsh1, Rsh2 and Rsh3 are the current transformer termination resistors. The voltage drop across the termination resistors should be at least 20mV but not higher than 200mV. The ideal value should be approximately 100mV at rated conditions. Values for the current sense inputs are calculated as follows:

$$R_1 = R_2 = (I_L / 16\mu\text{A}_{RMS}) \times R_{sh} / 2$$

$$R_3 = R_4 = (I_L / 16\mu\text{A}_{RMS}) \times R_{sh} / 2$$

$$R_5 = R_6 = (I_L / 16\mu\text{A}_{RMS}) \times R_{sh} / 2$$

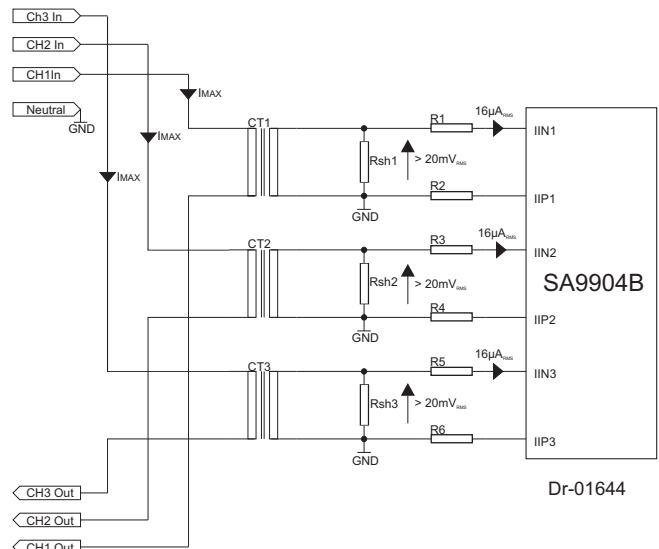

Dr-01644

Figure 5: Current sense input configuration



## SA9904B

sames

Where:

$I_L$  = Line current or if a CT is used  $I_L$  = Line current / CT ratio

Rsh = Shunt resistor or CT termination resistor.

Rsh should be less than the resistance of the CT's secondary winding.

### Voltage Sense Input (IVP1, IVP2, IVP3)

Figure 6 shows the voltage sense (IVP) input configuration for one phase. The exact circuit is duplicated for the other two phases. The current into the voltage sense inputs (virtual ground) should be set to  $14\mu A_{RMS}$  at rated voltage conditions. The voltage sense inputs saturate at an input current of  $\pm 25\mu A$  peak.

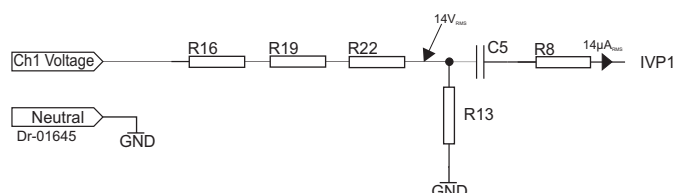

Figure 6: Voltage sense input configuration

The individual mains voltages are divided down to  $14V_{RMS}$  per phase. The resistor R8 sets the current for the voltage sense input. The voltage divider is calculated for a voltage drop of 14V. With a phase voltage of 230V the equation for the voltage divider is:

$$R_A = R_{16} + R_{19} + R_{22}$$

$$R_B = R_8 \parallel R_{13}$$

Combining the two equations gives:

$$(R_A + R_B) / 230V = R_B / 14V$$

A 24K resistor is chosen for R13 and a 1M resistor for R8.

Substituting these values results in:

$$R_B = 23.44K$$

$$R_A = R_B \times (230V / 14V - 1)$$

$$R_A = 361.6K$$

Resistor values for R16, R19 and R22 is chosen to be 120K each.

The capacitor C5 is used to compensate for any phase shift between the voltage sense and current sense input caused by the current transformer. As an example to compensate for a phase shift of 0.18 degrees the capacitor value is calculated as follows:

$$C = 1 / (2 \times \pi \times \text{Mains frequency} \times R_5 \times \tan(\text{Phase shift angle}))$$

$$C = 1 / (2 \times \pi \times 50\text{Hz} \times 1M\Omega \times \tan(0.18 \text{ degrees}))$$

$$C = 1.013\mu F$$

### Reference Voltage (VREF)

The VREF pin is the reference for the bias resistor. With a bias resistor of 47k $\Omega$  connected to Vss optimum conditions are set.

### Serial Clock (SCK)

The SCK pin is used to synchronize data interchange between

the micro controller and the SA9904B. The clock signal on this pin is generated by the micro controller and determines the data transfer rate of the DO and DI pins.

### Serial Data In (DI)

The DI pin is the serial data input pin for the SA9904B. Data will be input at a rate determined by the Serial Clock (SCK). Data will be accepted only during an active chip select (CS).

### Chip Select (CS)

The CS input is used to address the SA9904B. An active high on this pin enables the SA9904B to initiate data exchange.

## OUTPUT SIGNALS

### Serial Data Out (DO)

The DO pin is the serial data output pin for the SA9904B. The Serial Clock (SCK) determines the data output rate. Data is only transferred during on active chip select (CS). This output is tri-state when CS is low.

### Mains Voltage sense zero crossover (F50)

The F50 output generates a signal, which follows the mains voltage zero crossings, see figure 7. This output generates a pulse on the rising edge of the mains voltage zero crossing point. Internal logic ensures that this signal is generated from a valid phase. Should all three phase be missing but power still applied to the SA9904B this output will generate a constant 54Hz signal. The micro controller can use the F50 to extract mains timing.

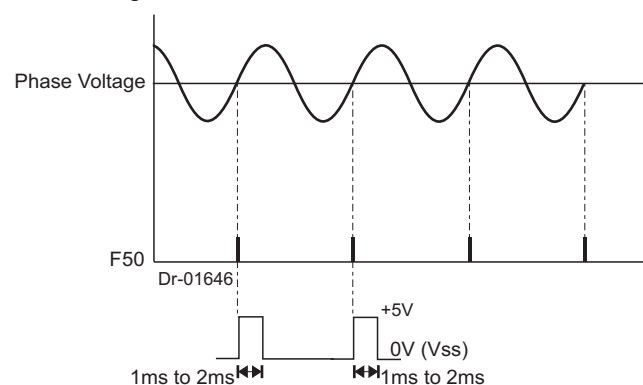

Figure 7: Mains voltage zero crossover

## SPI - INTERFACE

### Description

A serial peripheral interface bus (SPI) is a synchronous bus used for data transfers between a micro controller and the SA9904B. The pins DO (Serial Data Out), DI (Serial Data In), CS (Chip Select), and SCK (Serial Clock) are used in the bus implementation. The SA9904B is the slave device with the micro controller being bus master. The CS input initiates and terminates data transfers. A SCK signal (generated by the micro controller) strobes data between the micro-controller



## SA9904B

sames

and the SCK pin of the SA9904B. The DI and DO pins are the serial data input and output pins for the SA9904B, respectively.

### Register Access

Table 1 lists the various register addresses. The SA9904B contains nine 24 bit- registers representing the active energy, reactive energy and the mains voltage for each phase. A tenth 24 bit register represents the mains frequency for any valid phase. To remain compatible with the SA9604A three addresses have been included. Any of the three addresses can be used to access the frequency register.

ID	Register	Header bits		A5	A4	A3	A2	A1	A0
1	Active Phase 1	1	1	0	X	X	0	0	0
2	Reactive Phase 1	1	1	0	X	X	0	0	1
3	Voltage Phase 1	1	1	0	X	X	0	0	1
4	Frequency	1	1	0	X	X	0	0	1
5	Active Phase 2	1	1	0	X	X	0	1	0
6	Reactive Phase 2	1	1	0	X	X	0	1	0
7	Voltage Phase 2	1	1	0	X	X	0	1	1
8	Frequency	1	1	0	X	X	0	1	1
9	Active Phase 3	1	1	0	X	X	1	0	0
10	Reactive Phase 3	1	1	0	X	X	1	0	0
11	Voltage Phase 3	1	1	0	X	X	1	0	1
12	Frequency	1	1	0	X	X	1	0	1

Table 1: Register address

The header bits 110 (0x06) must precede the 6-bit address of the register being accessed. When CS is HIGH, data on pin DI is clocked into the SA9904B on the rising edge of SCK. Figure 8 shows the data clocked into DI comprising of 1 1 0 A5 A4 A3 A2 A1 A0. Address locations A5 and A4 are included for compatibility with future developments.

Registers may be read individually and in any order. After a register has been read, the contents of the next register value will be shifted out on the DO pin with every SCK clock cycle. Data output on DO will continue until CS is inactive.

The 9 bits needed for register addressing can be padded with leading zeros when the micro-controller requires a 8 bit SPI word length. The following sequence is valid:

```

15 14 13 12 11 10 9 8 7 6 5 4 3 2 1 0
0 0 0 0 0 0 0 1 1 0 A5 A4 A3 A2 A1 A0
  
```

### Data format

Figure 8 shows the SPI waveforms and figure 9 the timing information. After the least significant digit of the address has been entered on the rising edge of SCK, the output DO goes low with the falling edge of SCK. Each subsequent falling edge transition on the SCK pin will validate the next data bit on the DO pin.

The content of each register consists of 24 bits of data. The MSB is shifted out first.

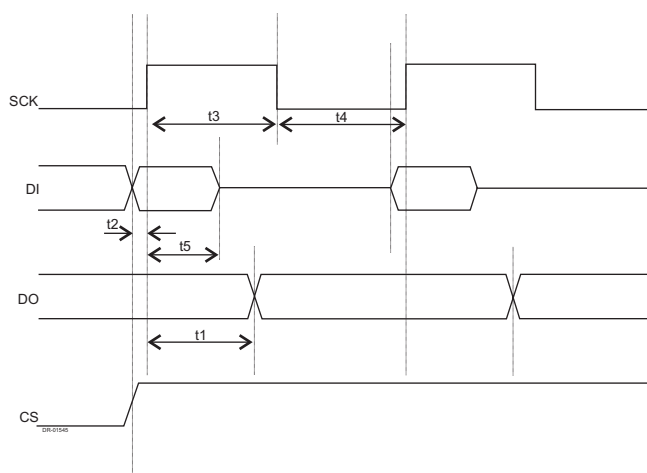

Parameter	Description	Min	Max
t1	SCK rising edge to DO valid	625ns	1.160µs
t3	SCK min high time	625ns	
t4	SCK min low time	625ns	
t2	Setup time for DI and CS before the rising edge of SCK	20ns	
t5	DI hold time	625ns	

Figure 9: SPI Timing diagrams with timing information

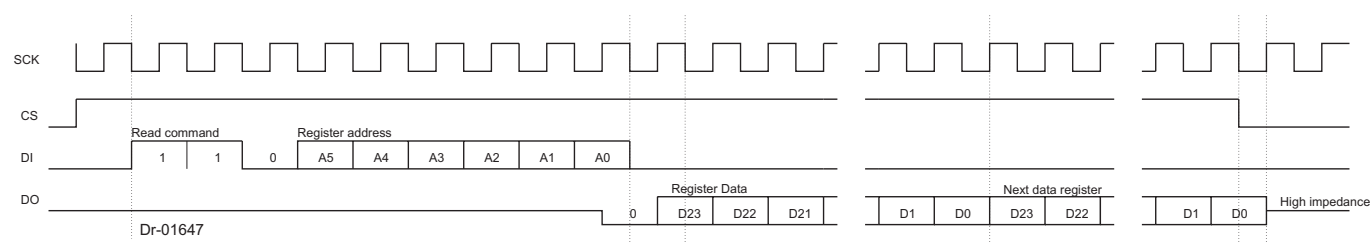

Figure 8: SPI waveforms



## REGISTER DESCRIPTION

### Active and reactive registers

The active and reactive power is accumulated in 24 bit registers for each phase. These registers are 24 bit up/down counters, that increment or decrement at a rate of 320k samples per second at rated conditions.

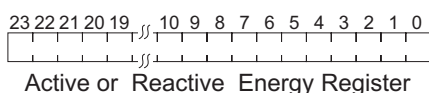

The register values will increment for positive energy flow and decrement for negative energy flow as indicated in figure 10.

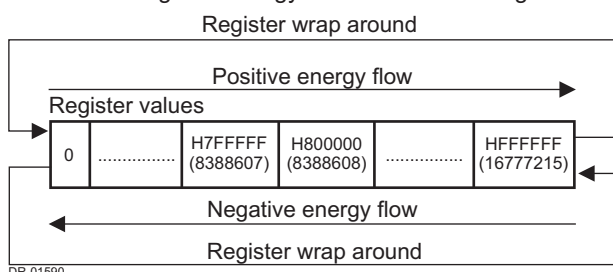

Figure 10: Register increment / decrement showing the register wrap around

The active and reactive registers are not reset after access, so in order to determine the correct register value, the previous value read must be subtracted from the current reading. The data read from the registers represents the active or reactive power integrated over time. The increase or decrease between readings represent the measured energy consumption. At rated conditions, the active and reactive registers will wrap around every 52 seconds. The micro controller program needs to take this condition into account when calculating the difference between register values.

As an example lets assume that with a constant load connected, the delta value (delta value = present register - previous register value) is 22260. Because of the constant load, the delta value should always be 22260 every time the register is read and the previous value subtracted (assuming the same time period between reads). However this will not be true when a wrap around occurs, as the following example will demonstrate:

Description	Variable	Decimal	Hex
Present register value	new_val	16767215	0x00FFD8EF
Previous register value	old_val	16744955	0x00FF81FB
new_val - old_val =	delta_val	22260	0x000056F4
The register now wraps around so after the next read the values are as follows:			
Present register value	new_val	12259	0x00002FE4
Previous register value	old_val	16767215	0x00FFD8EF
new_val - old_val =	delta_val	-16754956	0x00FFA90B

Using this delta value will result in incorrect calculations.

### Voltage registers

The three voltage registers contain the RMS voltage measured for each phase.

The RMS voltage measurement is accurate to 1% for a range of 50% to 115% of the rated mains voltage.

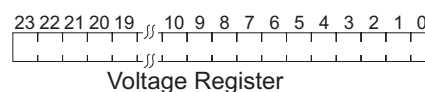

### Frequency register

The single frequency register contains the measured mains frequency information for a valid phase. Internal logic ensures that the frequency information is generated from the same phase being used for the F50 output. Only bits D0 to D9 are used for the frequency calculation however the remaining bits must still be clocked out as additional information can be derived from these data bits.

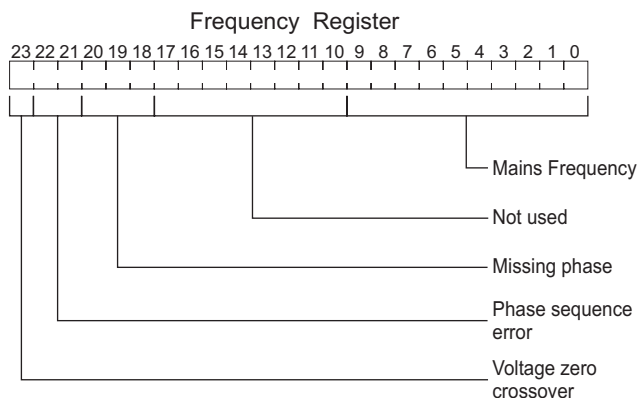

Bit location	Description																
0 to 9	These bits represent a value that is used in the frequency calculation																
10 to 17	Not used																
18,19,20	Missing phase. These bits indicate which phase is missing during a lost phase condition. <table border="1" style="margin-left: 20px;"> <thead> <tr> <th>D18</th> <th>D19</th> <th>D20</th> <th>Missing phase</th> </tr> </thead> <tbody> <tr> <td>1</td> <td>X</td> <td>X</td> <td>Phase 1</td> </tr> <tr> <td>X</td> <td>1</td> <td>X</td> <td>Phase 2</td> </tr> <tr> <td>X</td> <td>X</td> <td>1</td> <td>Phase 3</td> </tr> </tbody> </table>	D18	D19	D20	Missing phase	1	X	X	Phase 1	X	1	X	Phase 2	X	X	1	Phase 3
D18	D19	D20	Missing phase														
1	X	X	Phase 1														
X	1	X	Phase 2														
X	X	1	Phase 3														
21,22	The phase error status can be ascertained from these two bits. <table border="1" style="margin-left: 20px;"> <thead> <tr> <th>D21</th> <th>D22</th> <th>Missing phase</th> </tr> </thead> <tbody> <tr> <td>0</td> <td>0</td> <td>No phase error</td> </tr> <tr> <td>0</td> <td>1</td> <td>Phase sequence error.</td> </tr> <tr> <td>1</td> <td>X</td> <td>Missing phase</td> </tr> </tbody> </table>	D21	D22	Missing phase	0	0	No phase error	0	1	Phase sequence error.	1	X	Missing phase				
D21	D22	Missing phase															
0	0	No phase error															
0	1	Phase sequence error.															
1	X	Missing phase															
23	Voltage zero crossover. This bit changes state with the rising edge of the mains voltage.																

**POWER CALCULATION**

Instantaneous power signals are generated by multiplying the current and voltage signals, for active power =  $V \times I \times \cos(\theta)$  and for reactive power =  $V \times I \times \sin(\theta)$ . The power signals are continuously added to the respective energy registers. Positive power will be added to the energy register contents and negative energy will be subtracted.

**USING THE REGISTER VALUES****Active and Reactive energy register**

The active and reactive energy measured per count can be calculated by applying the following formulae:

$$\text{Energy per count} = (V_{\text{RATED}} \times I_{\text{RATED}}) / 320000$$

(In watt seconds or var seconds)

Where:

$V_{\text{RATED}}$  = Rated mains voltage of meter

$I_{\text{RATED}}$  = Rated mains current of meter

The active and reactive power measured by the SA9904B is calculated as follows:

$$\text{Power} = V_{\text{RATED}} \times I_{\text{RATED}} \times N / \text{INT}_{\text{TIME}} / 320000$$

(in Watt or VAR)

Where:

$V_{\text{RATED}}$  = Rated mains voltage of meter

$I_{\text{RATED}}$  = Rated mains current of meter

$N$  = Difference in register values between successive reads (delta value)

$\text{INT}_{\text{TIME}}$  = Time difference between successive register reads (in seconds)

**Mains voltage register**

The RMS voltage measurement is accurate to 1% in a range of 50% to 115% of rated mains voltage. The RMS mains voltage measured by the SA9904B is calculated as follows:

$$\text{Voltage} = V_{\text{RATED}} \times V_{\text{REGISTER VALUE}} / 700$$

Where

$V_{\text{RATED}}$  = Rated mains voltage of meter

$V_{\text{REGISTER VALUE}}$  = Voltage register value

**Mains frequency register**

The mains frequency measured by the SA9904B is calculated as follows:

$$\text{Frequency} = F_{\text{CRYSTAL}} / 256 / F_{\text{REGISTER VALUE}}$$

where

$F_{\text{CRYSTAL}}$  = The external crystal frequency.

$F_{\text{REGISTER VALUE}}$  = Bits D9 to D0 of the frequency register.



**TYPICAL APPLICATION**

In figure 11, the components required for the three phase power/energy metering section of a meter, is shown. The application uses current transformers for current sensing. The 4-wire meter section is capable of measuring 3x230V/80A with precision better than Class 1.

The most important external components for the SA9904B integrated circuit are the current sense resistors, the voltage sense resistors as well as the bias setting resistor.

**BIAS RESISTOR**

R7 defines all on-chip and reference currents. With R7=47kΩ, optimum conditions are set.

**CT TERMINATION RESISTOR**

The voltage drop across the CT termination resistor at rated current should be at least 20mV. The CT's used have low phase shift and a ratio of 1:2500. The CT is terminated with a 2.7Ω resistor giving a voltage drop across the termination resistor 86.4mV at rated conditions (Imax for the meter).

**CURRENT SENSE RESISTORS**

The resistors R1 and R2 define the current level into the current sense inputs of phase one of the device. The resistor values are selected for an input current of 16μA on the current inputs at rated conditions.

According to equation described in the Current Sense inputs section:

$$\begin{aligned} R1 = R2 &= (I_L / 16\mu A) \times R_{SH} / 2 \\ &= 80A / 2500 / 16\mu A \times 2.7\Omega / 2 \\ &= 2.7k\Omega \end{aligned}$$

$I_L$  = Line current / CT Ratio

The three current channels are identical so R1 = R2 = R3 = R4 = R5 = R6.

**VOLTAGE DIVIDER**

The voltage divider is calculated for a voltage drop of 14V. Equations for the voltage divider in figure 5 are:

$$R_A = R_{16} + R_{19} + R_{22}$$

$$R_B = R_8 \parallel R_{13}$$

Combining the two equations gives:

$$(R_A + R_B) / 230V = R_B / 14V$$

A 24k resistor is chosen for R13 and a 1M resistor is used for R8.

Substituting the values result in:

$$R_B = 23.44k$$

$$R_A = R_B \times (230V / 14V - 1)$$

$$R_A = 361.6k$$

Resistor values of R16, R19 and R22 is chosen to be 120k each.

The three voltage channels are identical so R14= R15= R16 = R17 = R18 = R19 and R20 = R21= R22.

**CRYSTAL OSCILLATOR**

A color burst TV crystal with f = 3.5795MHz is used for the oscillator. The oscillator frequency is divided down to 1.7897MHz on-chip, to supply the A/D converters as well as the digital circuitry.

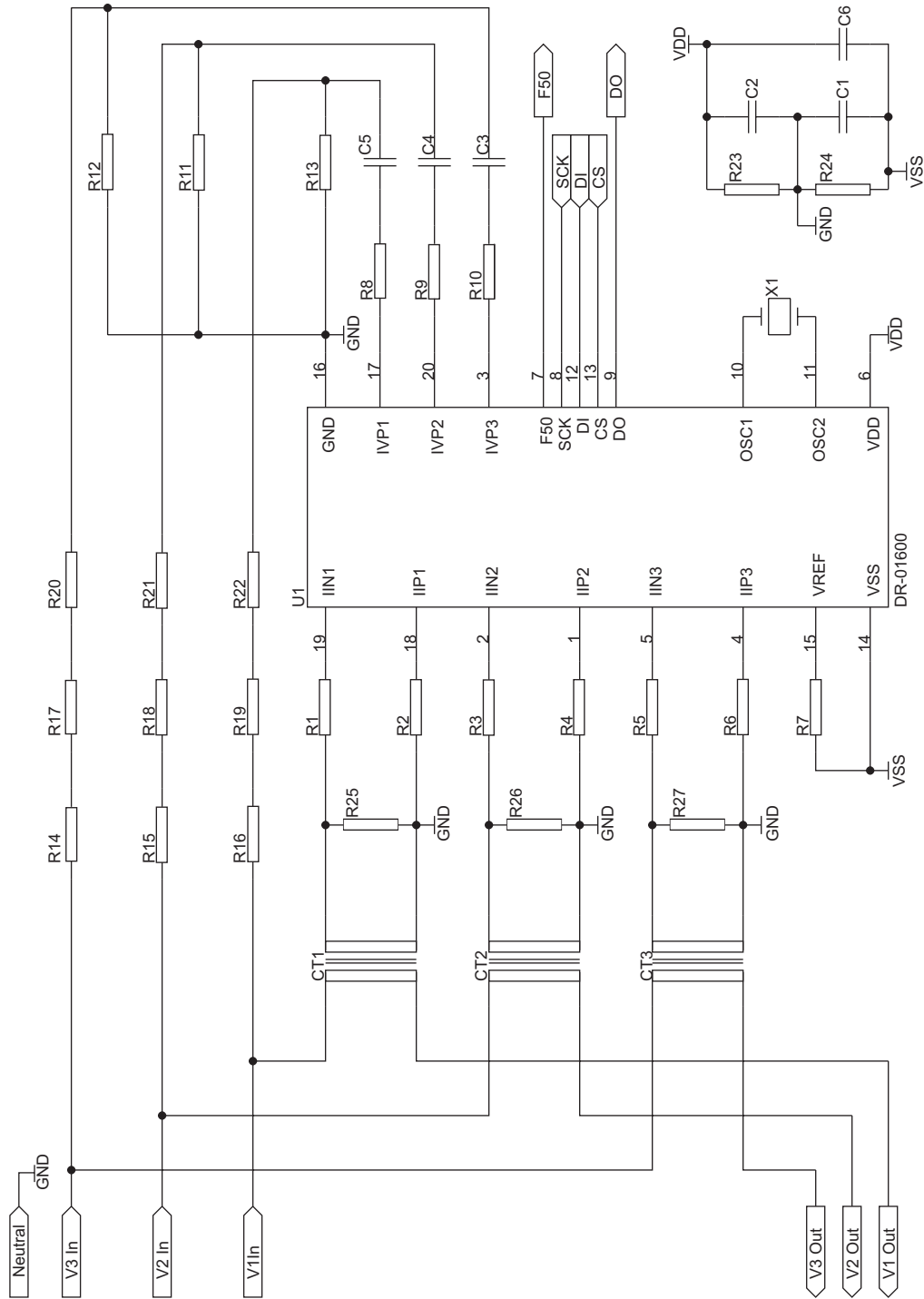

Figure 11: Typical application circuit



## Parts List for Application Circuit: Figure 11

Symbol	Description	Detail
U1	SA9904B	PDIP20 / SOIC20
R1	Resistor, 2.7k, 1/4W, 1% metal	Note 1
R2	Resistor, 2.7k, 1/4W, 1% metal	Note 1
R3	Resistor, 2.7k, 1/4W, 1% metal	Note 1
R4	Resistor, 2.7k, 1/4W, 1% metal	Note 1
R5	Resistor, 2.7k, 1/4W, 1% metal	Note 1
R6	Resistor, 2.7k, 1/4W, 1% metal	Note 1
R7	Resistor, 47k, 1/4W, 1%, metal	
R8	Resistor, 1M, 1/4W, 1%, metal	
R9	Resistor, 1M, 1/4W, 1%, metal	
R10	Resistor, 1M, 1/4W, 1%, metal	
R11	Resistor, 24k, 1/4W, 1%, metal	
R12	Resistor, 24k, 1/4W, 1%, metal	
R13	Resistor, 24k, 1/4W, 1%, metal	
R14	Resistor, 120k, 1/4W, 1%, metal	
R15	Resistor, 120k, 1/4W, 1%, metal	
R16	Resistor, 120k, 1/4W, 1%, metal	
R17	Resistor, 120k, 1/4W, 1%, metal	
R18	Resistor, 120k, 1/4W, 1%, metal	
R19	Resistor, 120k, 1/4W, 1%, metal	
R20	Resistor, 120k, 1/4W, 1%, metal	
R21	Resistor, 120k, 1/4W, 1%, metal	
R22	Resistor, 120k, 1/4W, 1%, metal	
R23	Resistor, 1k, 1/4W, 1%, metal	
R24	Resistor, 1k, 1/4W, 1%, metal	
R25	Resistor, 2.7R, 1/4W, 1%, metal	Note 1
R26	Resistor, 2.7R, 1/4W, 1%, metal	Note 1
R27	Resistor, 2.7R, 1/4W, 1%, metal	Note 1
C1	Capacitor, 220nF	
C2	Capacitor, 220nF	
C3	Capacitor, 820nF	Note 2
C4	Capacitor, 820nF	Note 2
C5	Capacitor, 820nF	Note 2
C6	Capacitor, 820nF	Note 3
CT1	Current Transformer, TZ76	
CT2	Current Transformer, TZ76	
CT3	Current Transformer, TZ76	
X1	Crystal, 3.57954MHz	

**Note 1:** Resistor (R1 to R6) values are dependant on the selection of the termination resistors (R25 to R27) and CT combination.

**Note 2:** Capacitor values may be selected to compensate for phase errors caused by the current transformers.

**Note 3:** Capacitor C6 to be positioned as close as possible to supply pins V<sub>DD</sub> and V<sub>SS</sub> of U1.

**DISCLAIMER:**

The information contained in this document is confidential and proprietary to South African Micro-Electronic Systems (Pty) Ltd ("SAMES") and may not be copied or disclosed to a third party, in whole or in part, without the express written consent of SAMES. The information contained herein is current as of the date of publication; however, delivery of this document shall not under any circumstances create any implication that the information contained herein is correct as of any time subsequent to such date. SAMES does not undertake to inform any recipient of this document of any changes in the information contained herein, and SAMES expressly reserves the right to make changes in such information, without notification, even if such changes would render information contained herein inaccurate or incomplete. SAMES makes no representation or warranty that any circuit designed by reference to the information contained herein, will function without errors and as intended by the designer.

Any sales or technical questions may be posted to our e-mail address below:  
**[energy@sames.co.za](mailto:energy@sames.co.za)**

For the latest updates on datasheets, please visit our web site:  
**<http://www.sames.co.za>**.

**SOUTH AFRICAN MICRO-ELECTRONIC  
SYSTEMS (PTY) LTD**

**Tel:** (012) 333-6021  
**Tel: Int** +27 12 333-6021  
**Fax:** (012) 333-8071  
**Fax: Int** +27 12 333-8071

**P O BOX 15888  
LYNN EAST  
0039  
REPUBLIC OF SOUTH AFRICA**

**33 ELAND STREET  
KOEDOESPOORT INDUSTRIAL AREA  
PRETORIA  
REPUBLIC OF SOUTH AFRICA**