



SC6121

INFRARED REMOTE CONTROL TRANSMITTER

DESCRIPTION

The SC6121 is a remote control transmitter utilizing CMOS Technology specially designed for use on infrared remote control applications. It is capable of controlling 32 function keys and 3 double keys. SC6121 is housed in a 20-pins SO package.

FEATURES

- * CMOS Technology
- * Low Operating Voltage (VDD=2.0~5.5V)
- * Using SEL pin, SC6121 can support 64+6 function codes
- * Customer Code can be selected

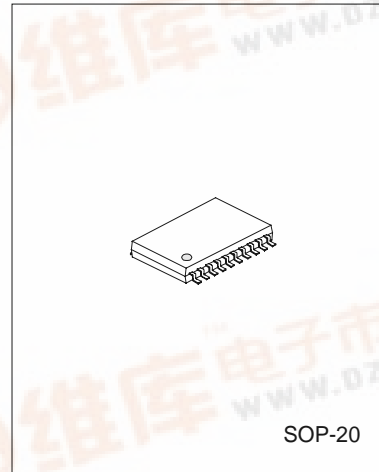

APPLICATIONS

- * TV and VCR
- * Audio Equipment
- * Cable TV Tuner
- * Cassette Deck
- * Air Conditioner
- * VCD and DVD ROM/Player
- * Moniputer/Multi-Media Personal Computer System

ORDERING INFORMATION

SC6121-001	ROM Content=0
SC6121-002	Custom Version

PIN CONFIGURATION

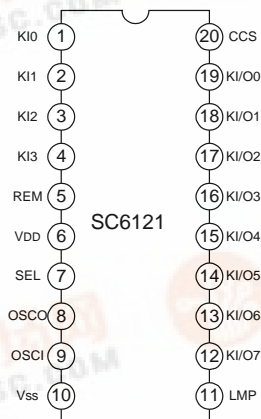

HANGZHOU SILAN MICROELECTRONICS JOINT-STOCK CO.,LTD

Rev: 1.2 2002-02-28



BLOCK DIAGRAM

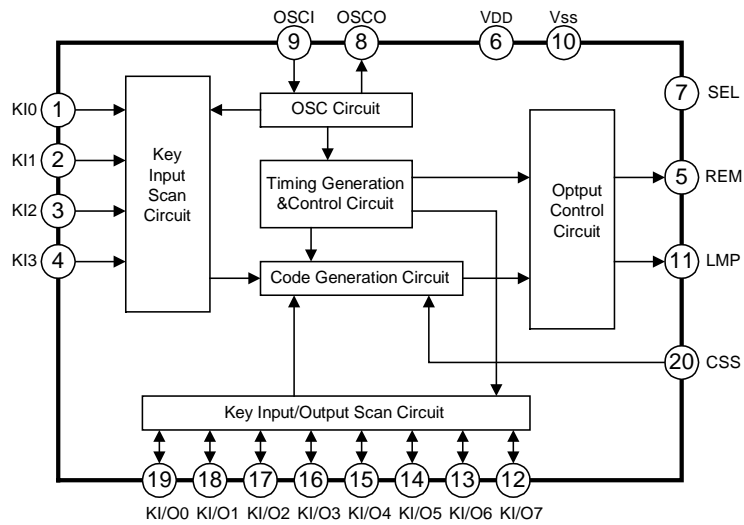

ABSOLUTE MAXIMUM RATING (Tamb=25°C, unless otherwise specified)

Characteristic	Symbol	Value	Unit
Supply Voltage	V _{DD}	6.0	V
Input Voltage	V _{IN}	-0.3~V _{DD}	V
Power Dissipation	P _d	250	mW
Storage Temperature	T _{stg}	-40~+125	°C
Operating Temperature	T _{opr}	-20~+75	°C

RECOMMENDED OPERATING CONDITIONS (Tamb=25°C, unless otherwise specified)

Characteristic	Symbol	Min.	Typ.	Max.	Unit
Supply Voltage	V _{DD}	2.0	3.0	3.3	V
Oscillation Frequency	f _{osc}	400	455	500	KHz
Input Voltage	V _{IN}	0	--	V _{DD}	V
Custom Code Select Pull-Up Resistance	R _{up}	--	100	--	KΩ

ELECTRICAL CHARACTERISTICS (T_{amb}=25°C, V_{DD}=3.0V, unless otherwise specified)

Parameter	Symbol	Test conditions	Min	Typ	Max	Unit
Supply Voltage	V _{DD}		2.0	3.0	5.5	V
Current Consumption 1	I _{DD1}	Fosc =455KHz		0.1	1.0	mA
Current Consumption 2	I _{DD2}	Fosc =STOP			1.0	μA
REM High Level Output Current	I _{OH1}	V _o =1.5V	-5.0	-8.0		mA
REM Low Level Output Current	I _{OL1}	V _o =0.3V	15	30		μA
LMP High Level Output Current	I _{OH2}	V _o =2.7V	-15	-30		μA
LMP Low Level Output Current	I _{OL2}	V _o =0.3V	1	1.5		mA
KI High Level Input Current	I _{IH1}	V _{IN} =3.0V	5		30	μA
KI Low Level Input Current	I _{IL1}	V _{IN} =0V			-0.2	μA
KI High Level Input Voltage	V _{IH1}		0.7 V _{DD}		V _{DD}	V
KI Low Level Input Voltage	V _{IL1}		0		0.3 V _{DD}	V
KI/O High Level Input Voltage	V _{IH2}		0.7 V _{DD}		V _{DD}	V
KI/O Low Level Input Voltage	V _{IL2}		0		0.4	V
KI/O High Level Input Current	I _{IH2}	V _{IN} =3.0V	2		7	μA
KI/O Low Level Input Current	I _{IL2}	V _{IN} =0V			-0.2	μA
KI/O High Level Output Current	I _{OH3}	V _o =2.5V	0.5		1.5	mA
KI/O Low Level Output Current	I _{OL3}	V _o =1.7V	1.5		2.5	mA
CCS Low Level Input Voltage	V _{IH3}		1.1			V
CCS High Level Input Current	I _{IH3}	Pull Up V _{IN} =3.0V			0.2	μA
CCS Low Level Input Current	I _{IL3}	Pull Up V _{IN} =0V	-3		-15	μA
CCS High Level Input Current	I _{IH4}	Pull Down V _{IN} =3.0V	5		30	μA
CCS Low Level Input Current	I _{IL4}	Pull Down V _{IN} =0V			-0.2	μA

PIN DESCRIPTION

Pin No.	Symbol	I/O	Description
1~4	KI0~KI3	I	Key Input Pin Nos. 0~3
5	REM	O	Data Output Pin
6	V _{DD}	--	Power Supply
7	SEL	I	Select Pin
8	OSCO	O	Oscillator Pin
9	OSCI	I	Oscillator Pin
10	V _{SS}	--	Power Supply
11	LMP	--	Output LED Indicator
19~12	KI/O0~KI/O7	I/O	Key Input/Output Pin Nos.0~7
20	CCS	I	Custom Code Scan Input Pin

FUNCTIONAL DESCRIPTION

1. TRANSMISSION CODE

The transmission code consists of a leader code, 16-bits custom codes, and 8-bits data codes. The inverse code of the data code is also sent simultaneously. The following diagram shows this one frame construction.

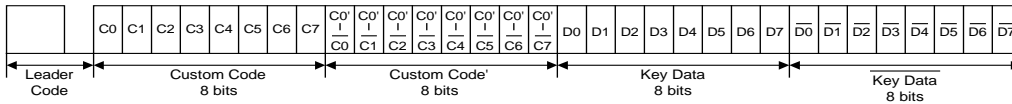

The leader codes consist of a 9ms carrier waveform followed by a 4.5ms OFF waveform. It is used as the leader for the following code. Thus, when reception is configured by a microcomputer, the time relationship between the reception detection and other processes can be managed efficiently. The code uses the PPM (Pulse Position Modulation) Method, with "0" and "1" differentiated by the time between pulses. Each code consists of 8 bits, and simultaneous transmission of the inverse code allows configuration of a system with an extremely low error rate.

2. KEY INPUT MATRIX

The Key Input Matrix of SC6121 is given below:

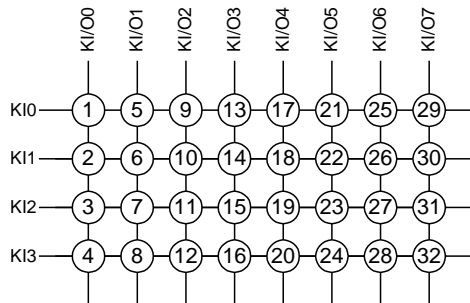

3. KEY INPUT

A total of 32 keys can be connected by SC6121 Key Input Pins--K10-K13 and the Timing Signal Output Pins KI/O0-KI/O7.

Double Key Operation is possible for only Key No.21 in combination with other keys connected to the KI/O5 line namely: Key No.22,23 or 24.thus, only the following key combinations may be used for the double key operation:

1. Key Nos.21 and 22
2. Key Nos.21 and 23
3. Key Nos.21 and 24

Pull-down resistors are connected between the Key Input and Vss Pins. When more than one key (except the double key combinations: K21+22, K21+23, K21+24) are pressed simultaneously, the transmission output stops.

Two key inputs are regarded as being pressed simultaneously when the time interval between these two key entries is less than 36ms.

The order of priority given to two key inputs with a time interval of more than 36ms is on a First-Pressed-First-Served or Longer-Pressed-First-Served Basis.

When a key is pressed, the custom and data codes are read. 36ms later, the Remote (REM) Output is activated. When the key is kept depressed during this 36ms, one transmission is outputted. If the key is depressed for more than 108ms, then the only the leader code is transmitted continuously.

4. DOUBLE KEY OPERATION

Double Key Operation is useful for operations such as tape deck recording. The following table shows the Key Data corresponding to the double keys pressed. Also refer to the Key Input Section.

The Double Key operation forms are as follows:

Key	D0	D1	D2	D3	D4	D5	D6	D7
K21+K22	1	0	1	0	1	1	0	0/1
K21+K23	0	1	1	0	1	1	0	0/1
K21+K24	1	1	1	0	1	1	0	0/1

Note: D7=1 when SEL is connected to VSS, or D7=0 when SEL is connected to VDD.

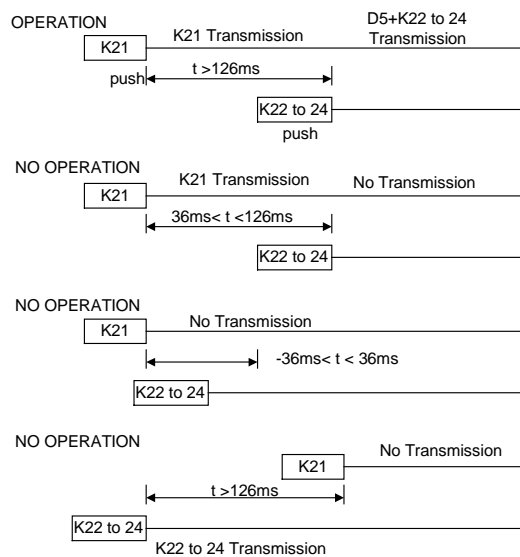

5. REMOTE OUTPUT WAVEFORMS

The Remote Output Waveforms are given in the diagram below:

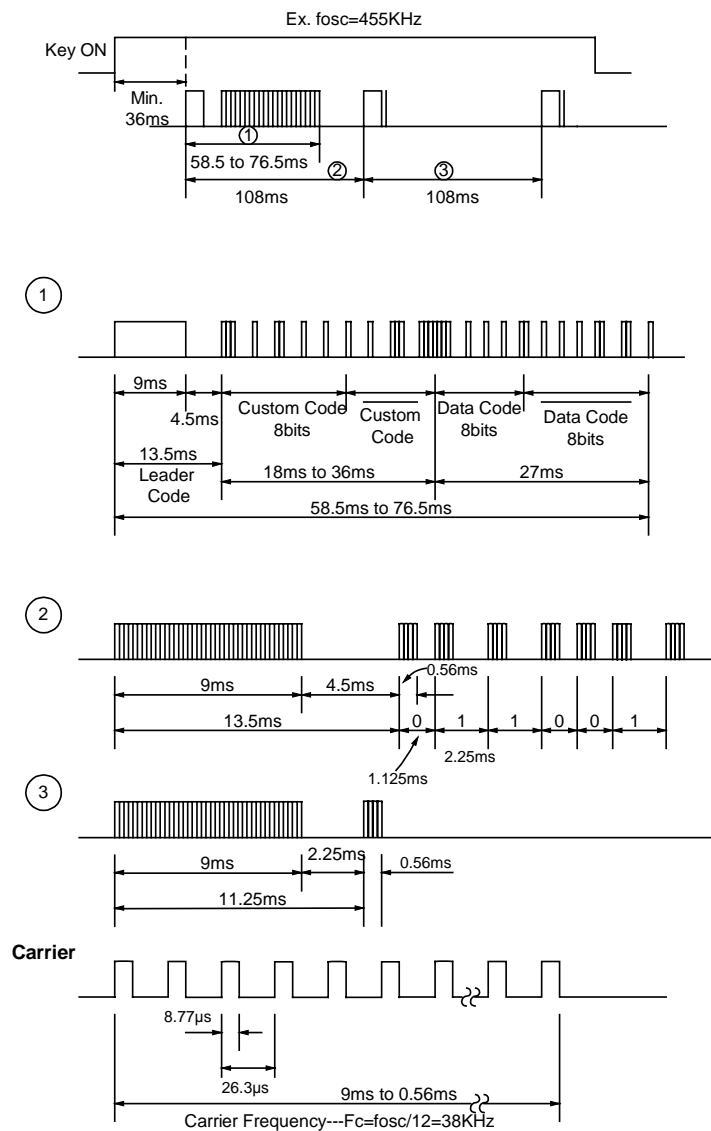

SC6121 KEYS DATA CODE

The Keys Data Code is given in the table below.

Key No.	Connection				K I/O	Data Code							
	KI0	KI1	KI2	KI3		D0	D1	D2	D3	D4	D5	D6	D7
K1	•				KI/O0	0	0	0	0	0	0	0	0/1
K2		•				1	0	0	0	0	0	0	0/1
K3			•			0	1	0	0	0	0	0	0/1
K4				•		1	1	0	0	0	0	0	0/1
K5	•				KI/O1	0	0	1	0	0	0	0	0/1
K6		•				1	0	1	0	0	0	0	0/1
K7			•			0	1	1	0	0	0	0	0/1
K8				•		1	1	1	0	0	0	0	0/1
K9	•				KI/O2	0	0	0	1	0	0	0	0/1
K10		•				1	0	0	1	0	0	0	0/1
K11			•			0	1	0	1	0	0	0	0/1
K12				•		1	1	0	1	0	0	0	0/1
K13	•				KI/O3	0	0	1	1	0	0	0	0/1
K14		•				1	0	1	1	0	0	0	0/1
K15			•			0	1	1	1	0	0	0	0/1
K16				•		1	1	1	1	0	0	0	0/1
K17	•				KI/O4	0	0	0	0	1	0	0	0/1
K18		•				1	0	0	0	1	0	0	0/1
K19			•			0	1	0	0	1	0	0	0/1
K20				•		1	1	0	0	1	0	0	0/1
K21	•				KI/O5	0	0	1	0	1	0	0	0/1
K22		•				1	0	1	0	1	0	0	0/1
K23			•			0	1	1	0	1	0	0	0/1
K24				•		1	1	1	0	1	0	0	0/1
K25	•				KI/O6	0	0	0	1	1	0	0	0/1
K26		•				1	0	0	1	1	0	0	0/1
K27			•			0	1	0	1	1	0	0	0/1
K28				•		1	1	0	1	1	0	0	0/1
K29	•				KI/O7	0	0	1	1	1	0	0	0/1
K30		•				1	0	1	1	1	0	0	0/1
K31			•			0	1	1	1	1	0	0	0/1
K32				•		1	1	1	1	1	0	0	0/1

Note: D7=1 when SEL is connected to VSS, or D7=0 when SEL is connected to VDD.

TYPICAL APPLICATION CIRCUIT

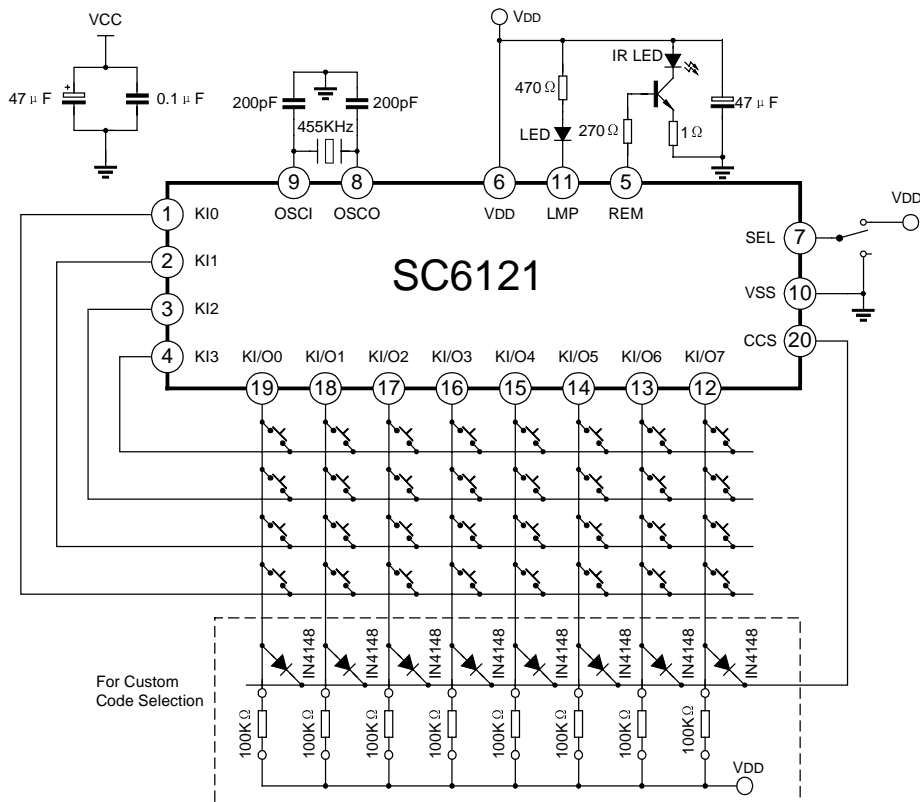

Note:1. Two capacitance connect with Vcc should as near as possible.

2. The line between two capacitance and Vcc and ground should as short as possible.

PCB WIRE LAYOUT SCHEMATIC:

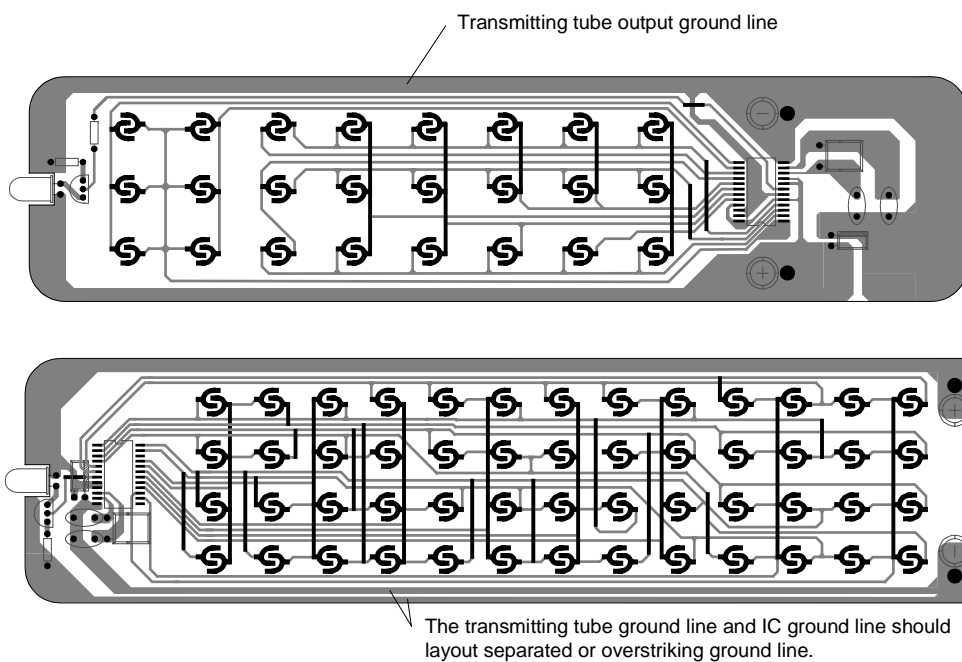

The above IC only use to hint, not to specified.

Note: :

- * In wire layout, the power filter capacitor should near to IC.
- * In wire layout, should avoid power line and ground line too long.
- * Recommended infrared transmit unit and IC ground line should layout separated, or overstriking lines.
- * The emitter of triode connect 1 Ω resistor at least.
- * Recommended triode use 9014.

PACKAGE OUTLINE

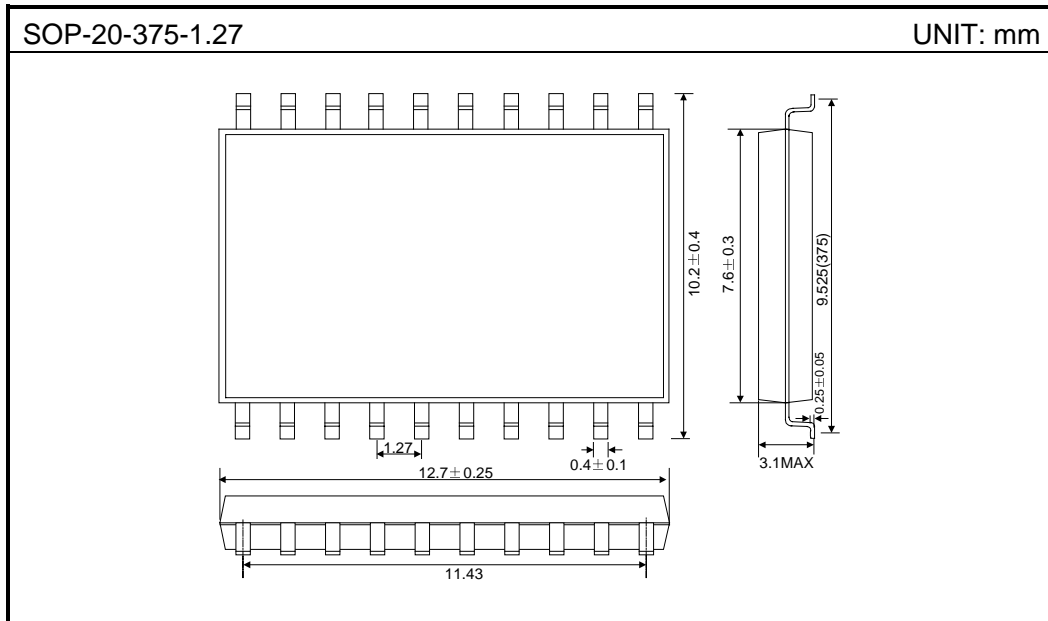

Attach

Revision History

Data	REV	Description	Page
2001.12.12	1.1		
2002.02.28	1.2	Modify the "Typical application circuit"	8
		Add the "PCB wire layout schematic"	9
		Modify the "Package outline"	10