



SC7313

DIGITAL CONTROLLED STEREO AUDIO PROCESSOR WITH LOUDNESS

DESCRIPTION

The SC7313 is a volume, tone (bass and treble), balance (left/right) and fader(front/rear) processor for quality audio applications in car radio and Hi-Fi systems. Selectable input gain and external loudness function are provided. Control is accomplished by serial I²C bus microprocessor interface. The AC signal settings is obtained by resistor networks and switches combined with operational amplifiers. Due to the Used BIPOLAR/CMOS technology, low distortion, low noise and low DC stepping are obtained.

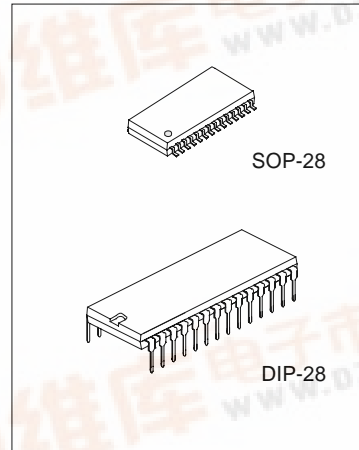

FEATURES

- * Input multiplexer:
 - 3 stereo inputs
 - Selectable input gain for optimal adaptation to different sources
- * Four speaker attenuators:
 - 4 independent speakers control in 1.25dB steps for balance and fader facilities
 - Independent mute function
- * All functions programmable via serial I²C Bus

ORDERING INFORMATION

Device	Package
SC7313	DIP-28-600-2.54
SC7313S	SOP-28-375-1.27

- * Loudness function
- * Volume control in 1.25dB steps
- * Treble and bass control
- * Input and output for external equalizer or noise reduction system

PIN CONFIGURATIONS

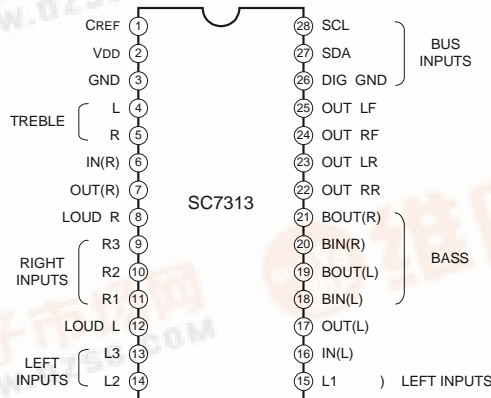

HANGZHOU SILAN MICROELECTRONICS JOINT-STOCK CO.,LTD

Rev: 1.1 2002.02.26



BLOCK DIAGRAM

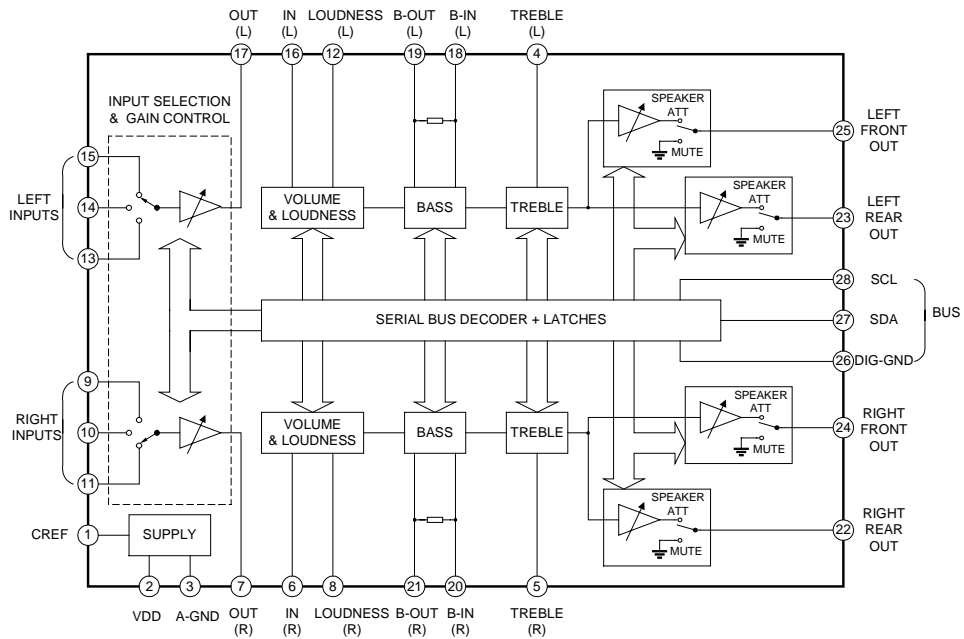

ABSOLUTE MAXIMUM RATINGS

Characteristic	Symbol	Value	Unit
Supply Voltage	Vs	10.2	V
Operating Temperature	Tamb	-40 ~ +85	°C
Storage Temperature	Tstg	-55 ~ +150	°C

QUICK REFERENCE DATA

Characteristic	Symbol	Min.	Typ.	Max.	Unit
Supply Voltage	Vs	6	9	10	V
Maximum input signal handling	VCL	2			Vrms
Total harmonic distortion, $V=1V_{rms}$, $f=1kHz$	THD		0.01	0.1	%
Signal to noise ratio	S/N		106		dB
Channel separation, $f=1kHz$	Sc		103		dB
Volume control, 1.25dB step		-78.75		0	dB
Bass and treble control, 2dB step		-14		+14	dB
Fader and balance control, 1.25dB step		-38.75		0	dB
Input gain, 3.75dB step		0		11.25	dB
Mute attenuation			100		dB

ELECTRICAL CHARACTERISTICS (Refer to the test circuit)

(Tamb=25°C, Vs=9.0V, RL=10kΩ, RG=600Ω, all controls flat(G=0), f=1kHz, Unless otherwise specified)

Parameter	Symbol	Test conditions	Min	Typ	Max	Unit
SUPPLY VOLTAGE						
Operating Supply Voltage	Vs		6	9	10.0	V
Operating Supply Current	Is			20.0	35.0	mA
Ripple rejection of Supply Voltage	SVR		60	80		dB
INPUTS SELECTORS						
Input resistance	R _{II}	Input 1,2,3	35	50	70	kΩ
Clipping Level	V _{CL}		2	2.5		V _{rms}
Input Separation (note 2)	S _{IN}		80	100		dB
Output load resistance	R _L	Pin7,17	4			kΩ
Minimum input Gain	G _{IN(MIN)}		-1	0	1	dB
Maximum input gain	G _{IN(MAX)}			11.25		dB
Step resolution	G _{STEP}			3.75		dB
Input noise	e _{IN}	G=11.25dB		2		μV
DC steps	V _{DC}	Adjacent gain steps		4	20	mV
		G=18.75 to MUTE		4		mV
VOLUME CONTROL						
Input resistance	R _{IV}		20	33	50	kΩ
Control range	C _{range}		70	75	80	dB
Minimum attenuation	A _{V(min)}		-1	0	1	dB
Maximum attenuation	A _{V(max)}		70	75	80	dB
Step resolution	A _{STEP}		0.5	1.25	1.75	dB
Attenuation set error	EA	A _V =0 to -20dB	-1.25	0	1.25	dB
		A _V =-20 to -60dB	-3		2	
Tracking error	ET				2	dB
DC steps	V _{DC}	Adjacent attenuation steps		0	3	mV
		From 0dB to A _V max		0.5	7.5	mV
SPEAKER ATTENUATORS						
Control Range	C _{range}		35	37.5	40	dB
Step resolution	S _{STEP}		0.5	1.25	1.75	dB
Attenuation Set error	EA				1.5	dB
Output Mute Attenuation	A _{MUTE}		80	100		dB
DC steps	V _{DC}	Adjacent attenuation steps		0	3	mV
		From 0dB to MUTE		1	10	mV

(continued)

Parameter	Symbol	Test conditions	Min	Typ	Max	Unit
BASS CONTROL (note 1)						
Control Range	GB	Maximum boost/cut	±12	±14	±16	dB
Step resolution	BSTEP		1	2	3	dB
Internal feedback resistance	Rb		34	44	58	kΩ
TREBLE CONTROL (note 1)						
Control Range	Gt	Maximum boost/cut	±13	±14	±15	dB
Step resolution	TSTEP		1	2	3	dB
AUDIO OUTPUTS						
Clipping level	VOCL	THD=0.3%	2	2.5		Vrms
Output load resistance	RL		4			kΩ
Output load capacitance	CL				10	nF
Output resistance	ROUT		30	75	120	Ω
DC voltage level	VOUT		4.2	4.5	4.8	V
GENERAL						
Output noise	eNO	BW=20 ~20kHz, flat output muted		2.5		μV
		BW=20 ~20kHz, flat All gains=0dB		5	15	μV
		A curve, all gains =0 dB		3		μV
Signal to noise ratio	S/N	All gains=0dB; Vo=1Vrms		106		dB
Distortion	d	AV=0, VIN=10mV		0.01	0.1	%
		AV=-20dB, VIN=1Vrms		0.09	0.3	%
		AV=-20dB, VIN=0.3Vrms		0.04		%
Channel separation left/right	Sc		80	103		dB
Total tracking error		AV=0 to -20 dB		0	1	dB
		AV=-20 to -60 dB		0	2	dB
BUS INPUTS						
Input low voltage	VIL				1	V
Input high voltage	VIH		3			V
Input current	IIN		-5		+5	μA
Output voltage SDA acknowledge	Vo	Io=1.6mA			0.4	V

NOTES:

- (1) Bass and treble response see Figure 16. The center frequency and quality of the response behavior can be chosen by the external circuitry. A standard first order bass response can realized by a standard feedback network.
- (2) The selected input is grounded through the 2.2μF capacitor.

— HANGZHOU SILAN MICROELECTRONICS JOINT-STOCK CO.,LTD —

Rev: 1.1 2002.02.26

TYPICAL CHARACTERISTICS PERFORMANCE

Fig.1 Loudness vs. Volume Attention

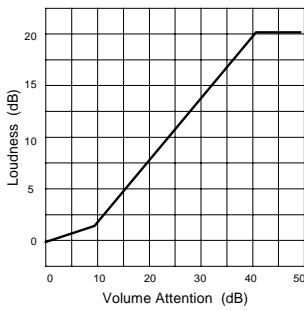

Fig.2 Loudness vs. Frequency vs. volume Attenuation

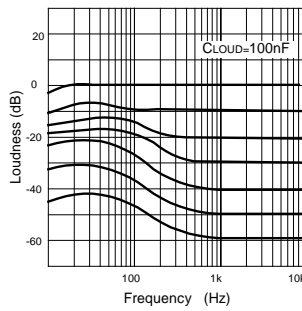

Fig.3 Loudness vs. External Capacitors

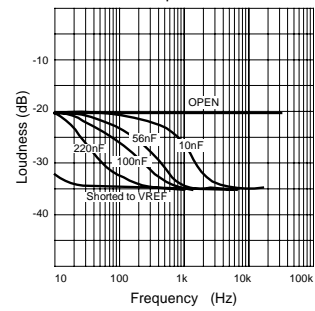

Fig.4 Noise vs. Volume/Gain settings

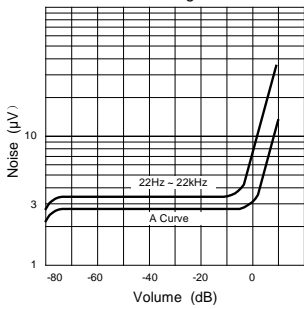

Fig.5 Signal to Noise Ratio vs. Volume settings

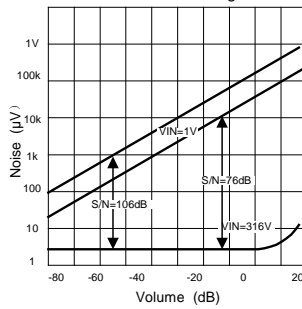

Fig.6 Distortion & Noise vs. Frequency

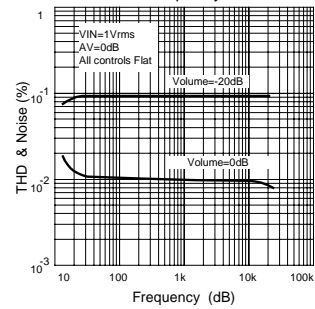

Fig.7 Distortion & Noise vs. Frequency

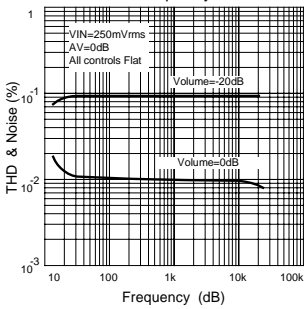

Fig.8 Distortion vs. Load Resistance

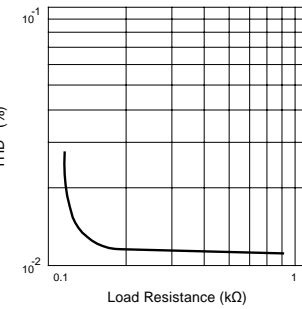
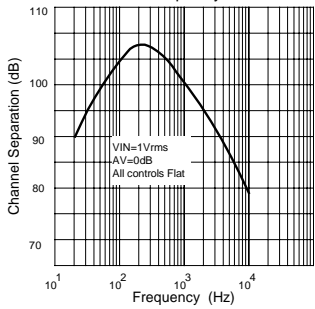
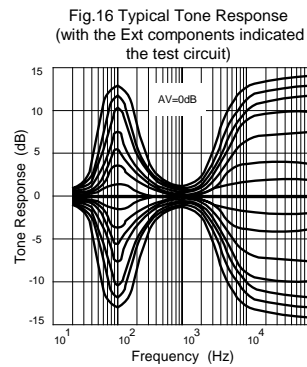
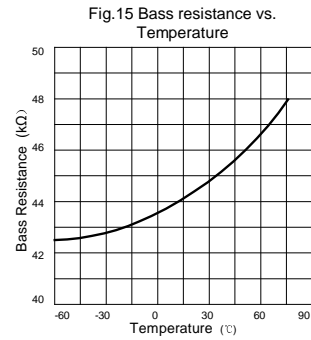
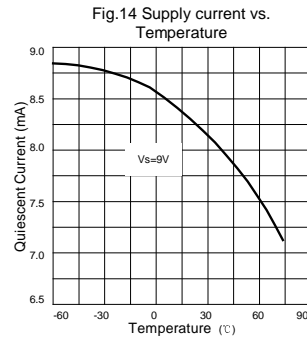
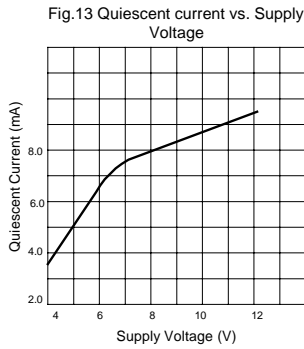
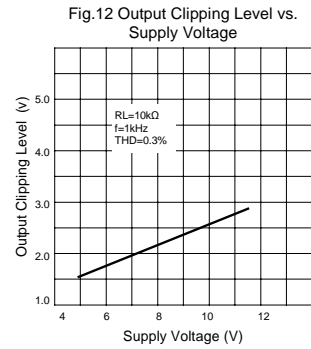
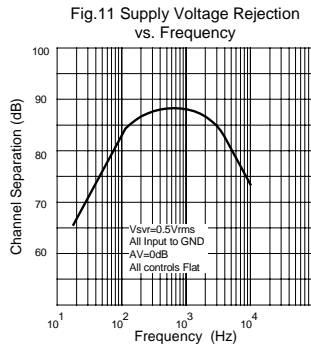
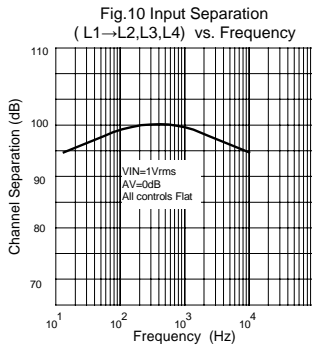

Fig.9 Channel Separation(L→R) vs. Frequency



TYPICAL CHARACTERISTICS PERFORMANCE (continued)



APPLICATION NOTES

1. I²C BUS INTERFACE

Data transmission from microprocessor to the SC7313 and viceversa takes place through the 2 wires I²C BUS interface, consisting of the two lines SDA and SCL(pull-up resistors to positive supply voltage must be connected).

2. DATA VALIDITY

As shown in Figure 17, the data of the SDA line must be stable during the high period of the clock. The HIGH and LOW state of the data line can only change when the clock signal on the SCL line is LOW.

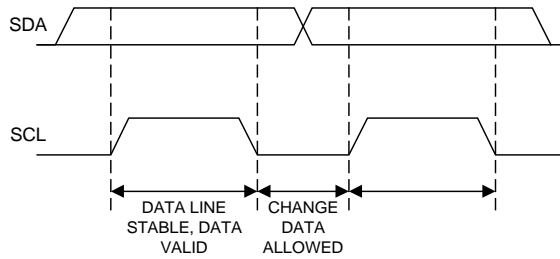

Fig. 17 Data Validity on the I²C BUS

3. START AND STOP CONDITIONS

As shown in Figure 18, a start condition is a HIGH to LOW transition of the SDA line while SCL is HIGH. The stop condition is a LOW to HIGH transition of the SDA line while SCL is HIGH.

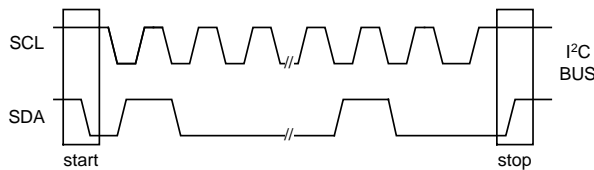

Fig. 18 Timing diagram of I²C BUS

4. BYTE FORMAT

Every byte transferred on the SDA line must obtain 8 bits. Each byte must be followed by the an acknowledge bit. The MSB is transferred first.

5. ACKNOWLEDGE

The master(microprocessor) puts a resistive HIGH level on the SDA line during the acknowledge clock pulse(see Figure 19). The peripheral(audioprocessor) that acknowledges has to pull-down(LOW) the SDA line during the acknowledge clock pulse, so that the SDA line is stable LOW during this clock pulse.

The audioprocessor which has been addressed has to generate an acknowledge after the reception of each byte , otherwise the SDA line remain at the HIGH level during the ninth clock pulse time. In this case the master transmitter can generate the STOP information in order to abort the transfer.

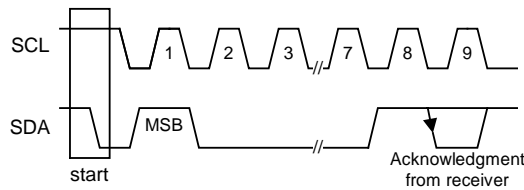

Fig. 19 Acknowledge on the I²C BUS

6. TRANSMISSION WITHOUT ACKNOWLEDGE

Avoiding to detect the acknowledge of the audioprocessor, the microprocessor can use a simpler transmission: simply it waits one clock without checking the slave acknowledgedig, and sends the new data.

This approach of course is less protected from mis-working and decreases the noise immunity.

SOFTWARE SPECIFICATION

1. Interface protocol

The interface protocol comprises:

- A start conditions
- A chip address byte, containing the SC7313 address(the 8th bit of the bytes must be 0). The SC7313 must always acknowledge at the end of each transmitted byte.
- A sequence of data(N-bytes + acknowledge)
- A stop condition (P)

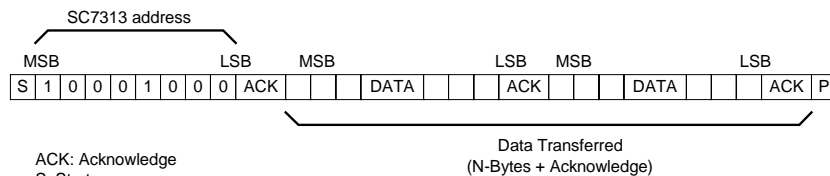

ACK: Acknowledge
 S: Start
 P: Stop
 Max clock speed: 100kbits/sec

2. Chips address

1 (MSB)	0	0	0	1	0	0	0 (LSB)
---------	---	---	---	---	---	---	---------

3. Data bytes

MSB							LSB	Function
0	0	B2	B1	B0	A2	A1	A0	Volume Control
1	1	0	B1	B0	A2	A1	A0	Speaker ATT LR
1	1	1	B1	B0	A2	A1	A0	Speaker ATT RR
1	0	0	B1	B0	A2	A1	A0	Speaker ATT LF
1	0	1	B1	B0	A2	A1	A0	Speaker ATT RF
0	1	0	G1	G0	S2	S1	S0	Audio switch
0	1	1	0	C3	C2	C1	C0	Bass control
0	1	1	1	C3	C2	C1	C0	Treble control

Note: Ax=1.25dB steps;Bx=10dB steps;Cx=2dB steps;Gx=3.75dB steps

DETAILED DESCRIPTION OF DATA BYTES

1. Volume

MSB							LSB	Function
0	0	B2	B1	B0	A2	A1	A0	Volume 1.25dB steps
					0	0	0	0
					0	0	1	-1.25
					0	1	0	-2.5
					0	1	1	-3.75
					1	0	0	-5
					1	0	1	-6.25
					1	1	0	-7.5
					1	1	1	-8.75
0	0	B2	B1	B0	A2	A1	A0	Volume 10dB steps
		0	0	0				0
		0	0	1				-10
		0	1	0				-20
		0	1	1				-30
		1	0	0				-40
		1	0	1				-50
		1	1	0				-60
		1	1	1				-70

For example, a volume of -45dB is given by: 00100100

2. speaker attenuators

MSB							LSB	Function
1	0	0	B1	B0	A2	A1	A0	Speaker ATT LF
1	0	1	B1	B0	A2	A1	A0	Speaker ATT RF
1	1	0	B1	B0	A2	A1	A0	Speaker ATT LR
1	1	1	B1	B0	A2	A1	A0	Speaker ATT RR
					0	0	0	0
					0	0	1	-1.25
					0	1	0	-2.5
					0	1	1	-3.75
					1	0	0	-5
					1	0	1	-6.25
					1	1	0	-7.5
					1	1	1	-8.75
			0	0				0
			0	1				-10
			1	0				-20
			1	1				-30
			1	1	1	1	1	MUTE

For example, attenuation of 25dB on speaker RF is given by: 10110100

4. Audio switch

MSB							LSB	Function
0	1	0	G1	G0	S2	S1	S0	Audio switch
						0	0	Stereo 1
						0	1	Stereo 2
						1	0	Stereo 3
						1	1	Stereo 4
					0			Loudness ON
					1			Loudness OFF
			0	0				+11.25dB
			0	1				+7.5dB
			1	0				+3.75dB
			1	1				0dB

For example, to select the stereo 2 input with a gain of +7.5dB Loudness ON the 8bit string is: 01001001

Note: Stereo4 is connected internally, but not available on pins.

5. Bass and treble

MSB				LSB				Function
0	1	1	0	C3	C2	C1	C0	Bass
0	1	1	1	C3	C2	C1	C0	Treble
				0	0	0	0	-14
				0	0	0	1	-12
				0	0	1	0	-10
				0	0	1	1	-8
				0	1	0	0	-6
				0	1	0	1	-4
				0	1	1	0	-2
				0	1	1	1	0
				1	1	1	1	0
				1	1	1	0	2
				1	1	0	1	4
				1	1	0	0	6
				1	0	1	1	8
				1	0	1	0	10
				1	0	0	1	12
				1	0	0	0	14

C3=Sign

For Example, bass at -10dB is obtained by the following 8bit string is: 01100010.

TEST AND TYPICAL APPLICATION CIRCUIT

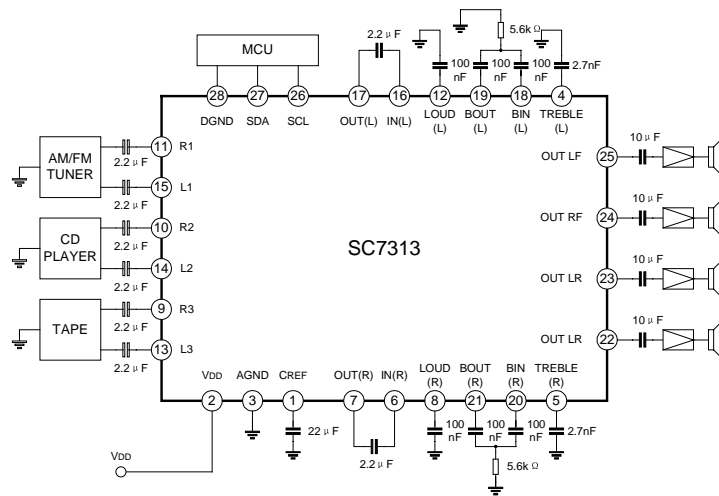

PACKAGE OUTLINE

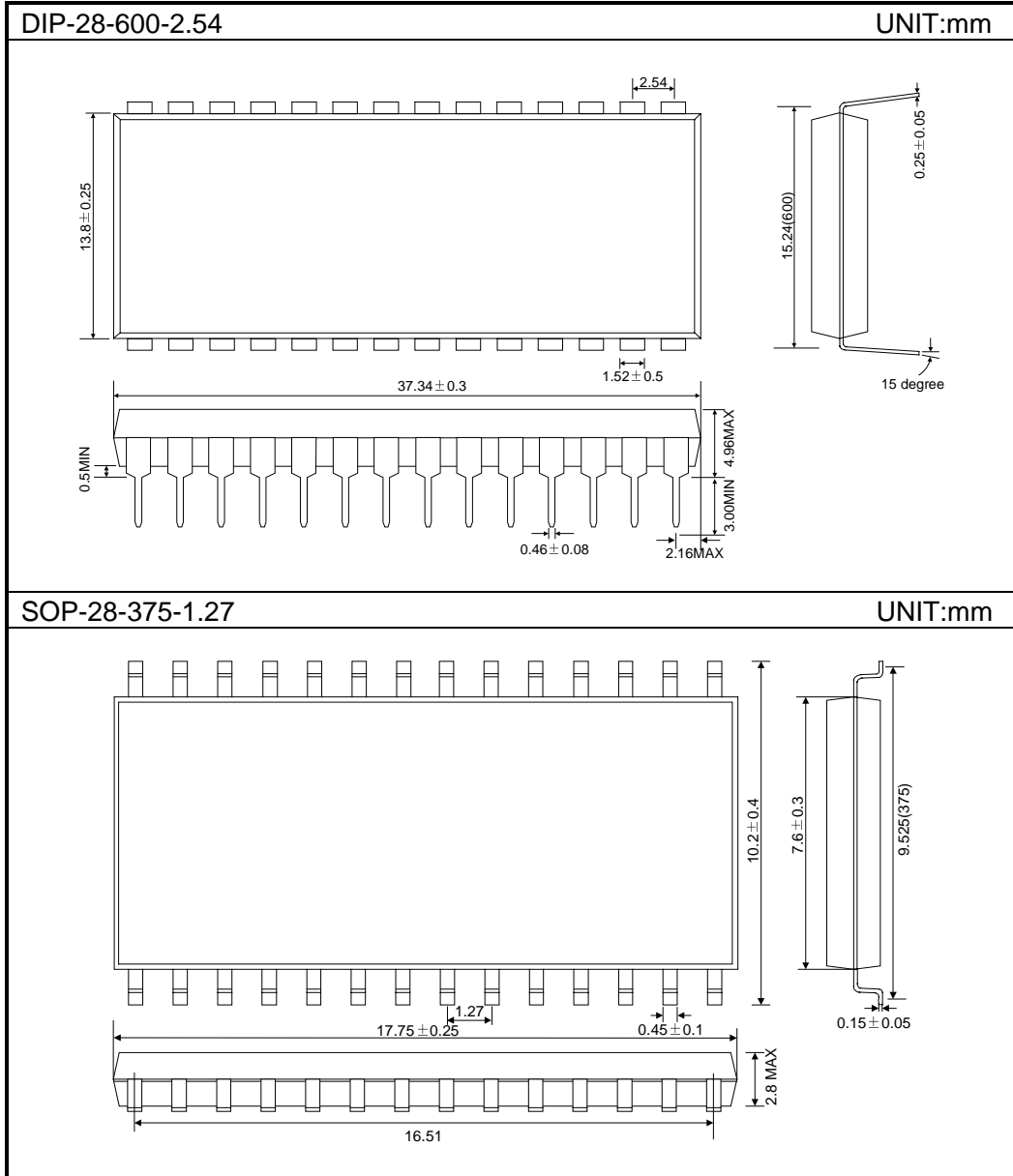

Attach

Revision History

Data	REV	Description	Page
2000.12.31	1.0	Original	
2002.02.26	1.1	Modify the "package outline"	12