



SD1143

RF & MICROWAVE TRANSISTORS

PRODUCT PREVIEW

DESCRIPTION

The SD1143 is a 12.2 V Class C epitaxial silicon NPN planar transistor designed primarily for VHF Communications. It withstands very high VSWR under operating conditions.

IMPORTANT: For the most current data, consult MICROSEMI's website: <http://www.microsemi.com>

KEY FEATURES

- 175 MHz
- 12.5 Volts
- Common Emitter
- $P_{OUT} = 10$ W Min.
- $G_p = 10$ dB Gain

APPLICATIONS/BENEFITS

- VHF Mobile Applications

ABSOLUTE MAXIMUM RATINGS (T_{case} = 25°C)

Symbol	Parameter	Value	Unit
V _{CBO}	Collector-Base Voltage	36	V
V _{CEO}	Collector-Emitter Voltage	18	V
V _{CES}	Collector-Emitter Voltage	36	V
V _{EBO}	Emitter-Base Voltage	4.0	V
I _C	Device Current	2.0	A
P _{DISS}	Power Dissipation	20	W
T _J	Junction Temperature	+200	°C
T _{STG}	Storage Temperature	-65 to +150	°C



.380 4LSTUD(M135)
epoxy sealed

THERMAL DATA

R _{TH(j-c)}	Junction-Case Thermal Resistance	8.75	°C/W
----------------------	----------------------------------	------	------

PIN CONNECTION

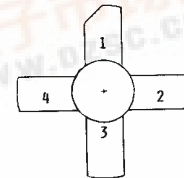

- 1 collector
- 2 emitter
- 3 base
- 4 emitter



STATIC ELECTRICAL SPECIFICATIONS (T_{CASE} = 25°C)

Symbol	Test Conditions	SD1143			Units
		Min.	Typ.	Max.	
BV_{CES}	I_C = 50 mA V_{BE} = 0 V	36	—	—	V
BV_{CEO}	I_C = 15 mA I_B = 0 mA	18	—	—	V
BV_{EBO}	I_E = 2.5 mA I_C = 0 mA	4.0	—	—	V
I_{CBO}	V_{CB} = 15 V I_E = 0 mA	—	—	1	mA
h_{FE}	V_{CE} = 5 V I_C = 250 mA	5	—	200	—

DYNAMIC ELECTRICAL SPECIFICATIONS (T_{CASE} = 25°C)

Symbol	Test Conditions	SD1143			Units
		Min.	Typ.	Max.	
P_{OUT}	f = 175 MHz P_{IN} = 1 W V_{CE} = 12.5 V	10	—	—	W
G_P	f = 175 MHz P_{IN} = 1 W V_{CE} = 12.5 V	10	—	—	dB
C_{OB}	f = 1 MHz V_{CB} = 15 V	—	—	45	pF

IMPEDANCE DATA

Freq.	Z _{IN} (Ω)	Z _{CL} (Ω)
175 MHz	1.3 – j.8	5.1 + j 3.8

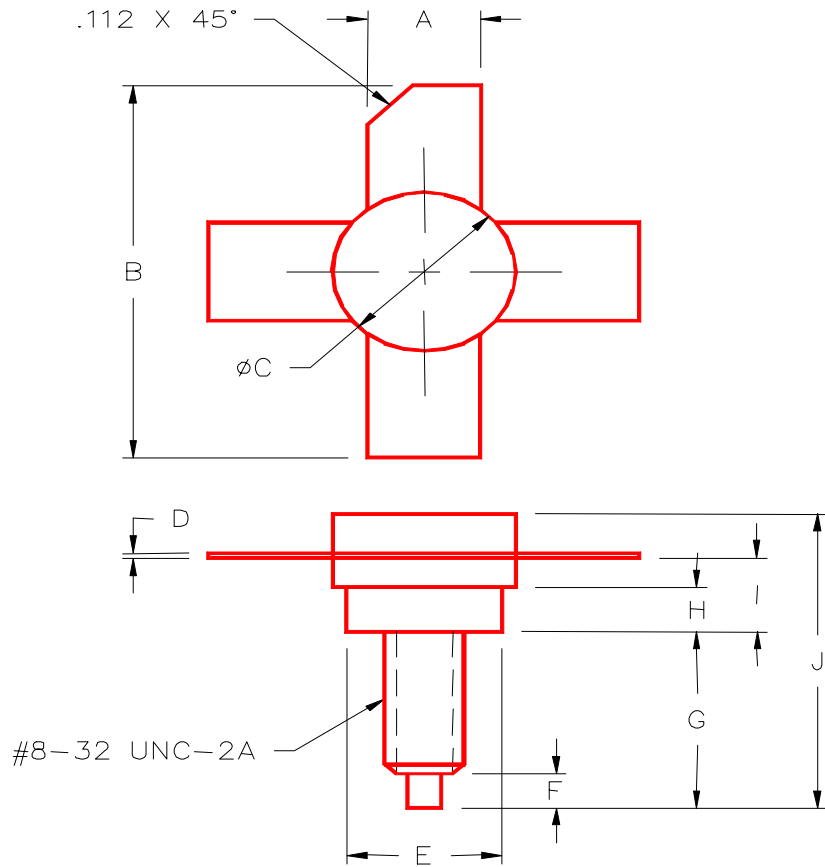
PACKAGE STYLE M135

	MINIMUM INCHES/MM	MAXIMUM INCHES/MM		MINIMUM INCHES/MM	MAXIMUM INCHES/MM
A	.220/5,59	.230/5,84	I	.155/3,94	.175/4,45
B	.980/24,89		J		.750/19,05
C	.370/9,40	.385/9,78			
D	.004/0,10	.007/0,18			
E	.320/8,13	.330/8,38			
F	.100/2,54	.130/3,30			
G	.450/11,43	.490/12,45			
H	.090/2,29	.100/2,54			



RF PRODUCTS DIVISION

SD1143

RF & MICROWAVE TRANSISTORS

PRODUCT PREVIEW

www.Microsemi.com

NOTES