



STA2051 VESPUCCI

32-BIT SINGLE CHIP BASEBAND CONTROLLER FOR GPS AND TELEMATIC APPLICATIONS

DATA BRIEF

1 FEATURES

- ARM7TDMI 16/32 bit RISC CPU based host microcontroller.
- Complete Embedded Memory System:
 - FLASH 256K bytes + 16K bytes (100K erasing/programming cycles)
 - RAM 64K bytes.
- External memory interface provides glueless support for up to four banks of external SRAM, FLASH, ROM.
- 12 channel GPS correlation DSP: – no TCXO required
 - RTCA-SC159 / WAAS / EGNOS support
- GPS performance
 - accuracy: stand alone <30m; differential <1m; surveying <1cm
 - time to first fix: autonomous start 90s; cold start 45s; warm start 7s; obscuration 1s.
- CMOS M8T (0.18 um) technology.
- -40°C to 85°C operating temperature range.
- 144-pin TQFP144 package or 64-pin TQFP64 package
- Power Supply:
 - 2.7V to 3.6V operating supply range for Input/Output periphery
 - 3 V to 3.6V operating supply range for A/ D Converter reference
 - 1.8V operating supply range for core supply provided either by internal Voltage Regulator with external stabilization capacitor, or by external supply for higher power efficiency.
- 0-66MHz internal clock frequency managed by a Reset and Clock Control Unit; the unitisable to provide low power modes (WAIT, SLOW, STOP, STANDBY) and to generate the internal clock from the external reference through integrated PLL.
- 48 programmable General Purpose I/O, each pin programmable independently as digital input or digital output; 40 (30 in TQFP64) are multiplexed with peripheral functions; 16 can generate an interrupt on input level/transition.
- Real time clock module with 3 2 KHz low power oscillator and separate power supply to continue running during stand-by mode.

Figure 1. Packages



Table 1. Order Codes

Part Number	Package
STA2051	TQFP64
STA2051E	TQFP144

- 16-bit Watchdog Timer with 8 bits prescaler for system reliability and integrity.
- CAN module compliant with the CAN specification V2.0 part B (active). The bit rate can be programmed up to 1 MBaud.
- Four 16-bit programmable Timers with 7 bit prescaler, up to two input capture/output compare, one pulse counter function, one PWM channel with selectable frequency each.
- 4 channels 12-bit sigma-delta Analog to Digital Converter, single channel or multi channel conversion modes, single-shot or continuous conversion modes, sample rate 1KHz (4 KHz when single channel), conversion range 0-2.5V.
- Three Serial Communication Interfaces (UART) allow full duplex, asynchronous, communications with external devices, independently programmable TX and RX baud rates up to 625K baud.
- One UART adapted to suit Smart Card interface needs, for asynchronous SC as defined by ISO 7816-3; it includes SC clock generation.
- Two Serial Peripheral Interfaces (SPI) allow full duplex, synchronous communications with external devices, master or slave operation, max baud rate: 8Mb/s. One SPI may be used as Multimedia Card interface.
- Two I²C Interfaces provide multi-master and slave functions, support normal and fast I²C mode (400KHz), 7/10 bit addressing modes. One I²C Interface is multiplexed with one SPI, so either 2xSPI+1xI²C or 1xSPI+2xI²C may be



STA2051 - VESPUCCI

used at a time.

- USB unit V1.1 compliant, software configurable end point setting, USB Suspend/Resume support. (TQFP144 only)
- High Level Data Link Controller (HDLC) unit supports full duplex operating mode, NRZ, NRZI, FM0 and MANCHESTER modes, internal 8bit Baud Rate Generator.

Figure 2. System Block Diagram

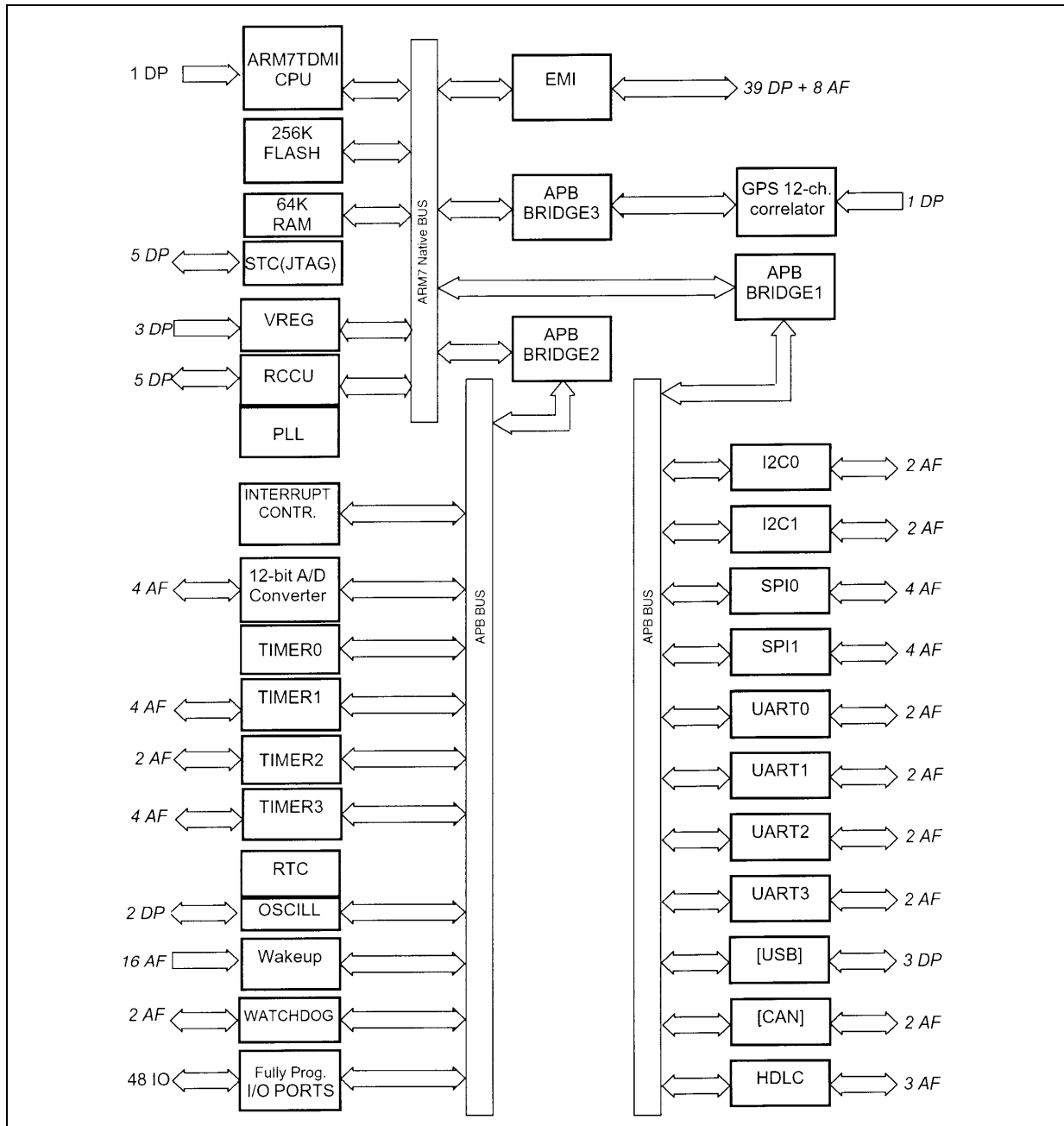

Figure 3. TQFP144 Pins Connection Diagram (Top view)

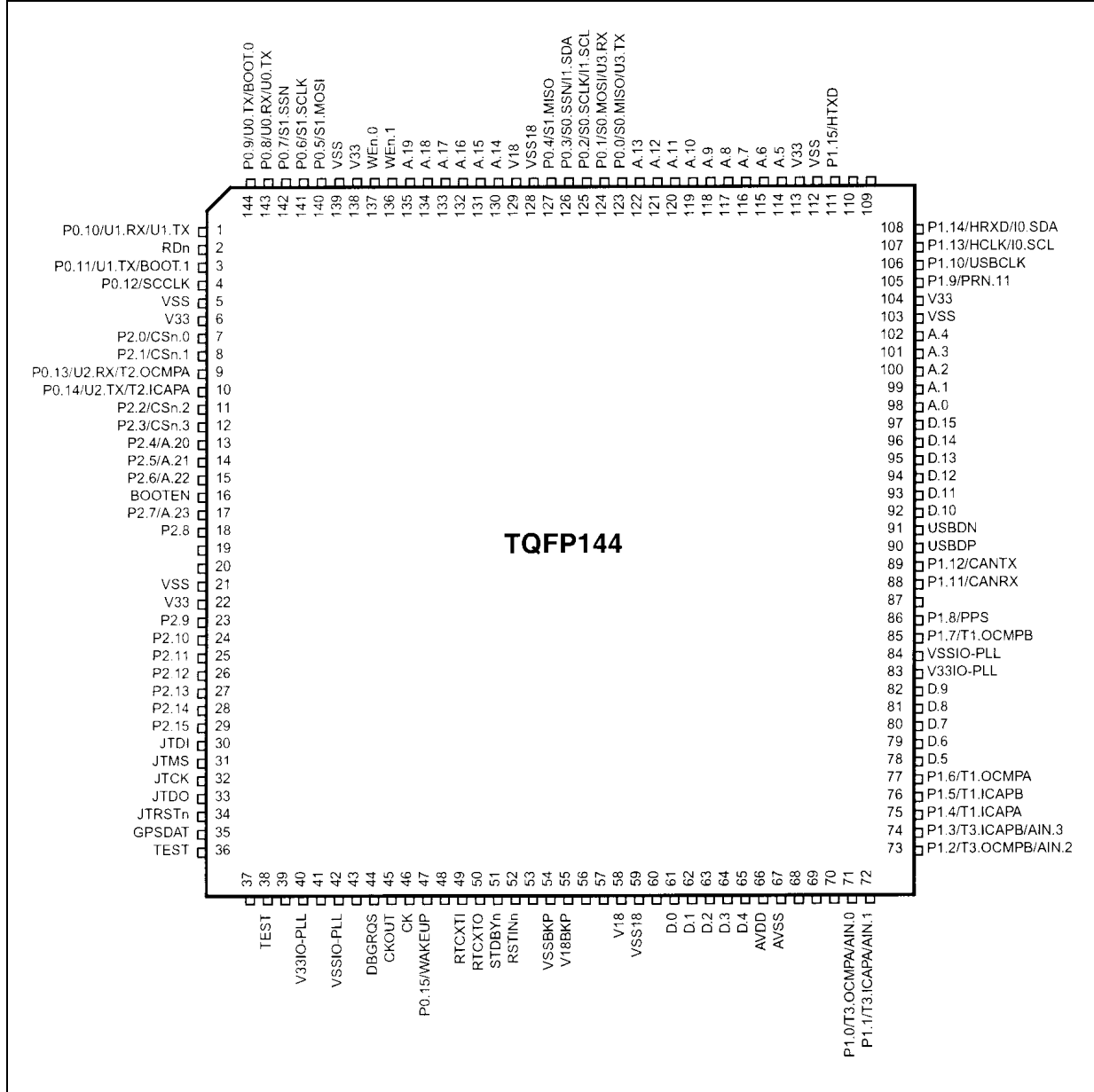

Figure 4. TQFP64 Pins Connection Diagram (Top view)

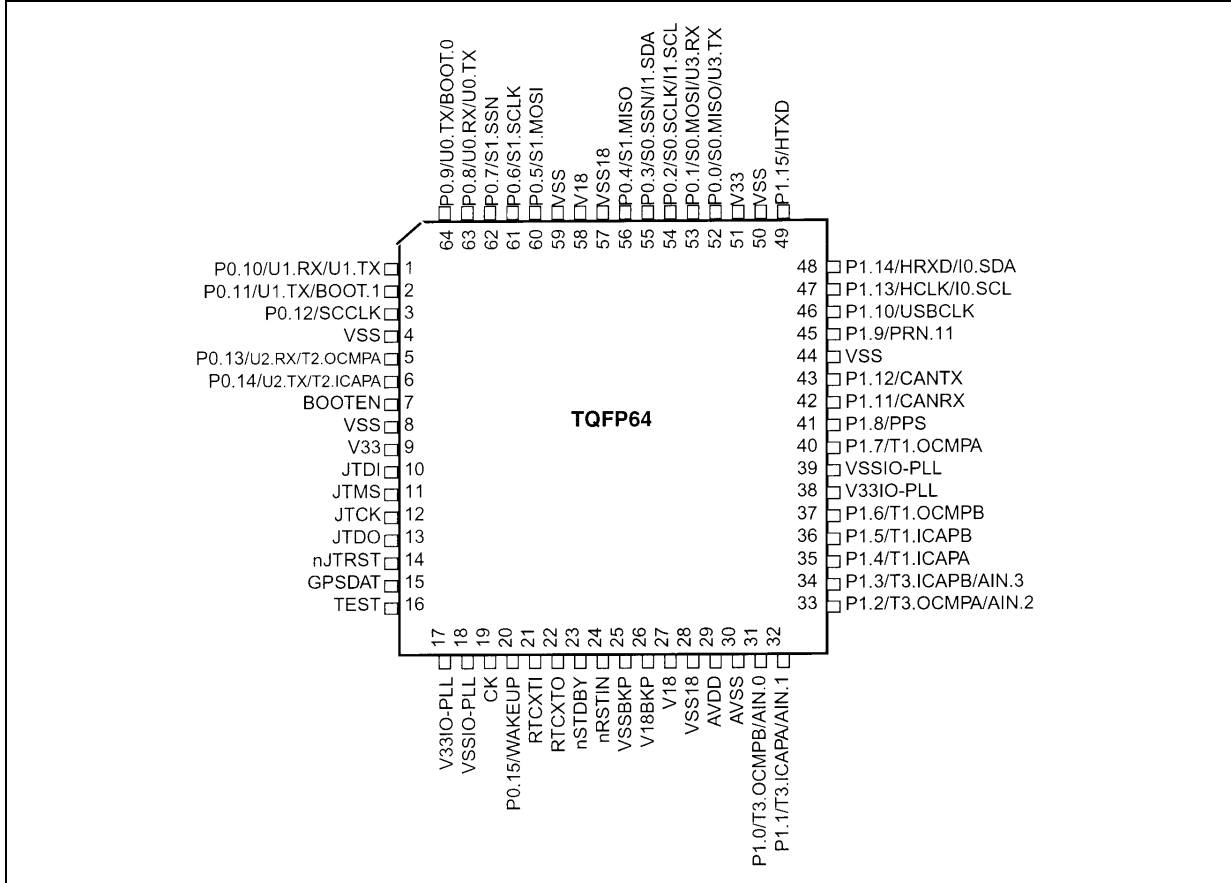

Table 2. Revision History

Date	Revision	Description of Changes
September 2004	1	First Issue

Information furnished is believed to be accurate and reliable. However, STMicroelectronics assumes no responsibility for the consequences of use of such information nor for any infringement of patents or other rights of third parties which may result from its use. No license is granted by implication or otherwise under any patent or patent rights of STMicroelectronics. Specifications mentioned in this publication are subject to change without notice. This publication supersedes and replaces all information previously supplied. STMicroelectronics products are not authorized for use as critical components in life support devices or systems without express written approval of STMicroelectronics.

The ST logo is a registered trademark of STMicroelectronics.
All other names are the property of their respective owners

© 2004 STMicroelectronics - All rights reserved

STMicroelectronics group of companies

Australia - Belgium - Brazil - Canada - China - Czech Republic - Finland - France - Germany - Hong Kong - India - Israel - Italy - Japan -
Malaysia - Malta - Morocco - Singapore - Spain - Sweden - Switzerland - United Kingdom - United States of America
www.st.com