

TOSHIBA

TA2104BN/BFN

TOSHIBA BIPOLAR LINEAR INTEGRATED CIRCUIT SILICON MONOLITHIC

TA2104BN, TA2104BFN

3 V AM / FM 1 CHIP TUNER IC

(for Digital Tuning System)

TA2104BN, TA2104BFN are AM/FM 1 chip tuner ICs, which are designed for portable Radios and 3 V Head phone Radios.

This is suitable for Digital Tuning System Applications. FM Local Oscillation Voltage is set up low relativity, for NEW FCC.

FUNCTIONS

- For NEW FCC.
- Suitable for combination with Digital Tuning System which is included IF Counter.
- One terminal type AM/FM IF count output for IF counter of Digital Tuning System.
 - FM : 1.3375 MHz (1 / 8 dividing)
 - AM : 450 kHz
- Built-in Mute Circuit for IF count output.
- For adopting ceramic Discriminator, it is not necessary to adjust the FM Quad Detector Circuit.
- Built-in FM MPX VCO circuit.
- Built-in one terminal type AM/FM Local Oscillator Buffer Output for Digital Tuning System Applications.
- Built-in AM Low cut circuit.
- Low supply current. ($V_{CC} = 3 V$, $T_a = 25^{\circ}C$)
 - I_{cc} (FM) = 11 mA (Typ.)
 - I_{cc} (AM) = 7 mA (Typ.)
- Operating Supply voltage range : $V_{CC} = 1.8\sim 7 V$ ($T_a = 25^{\circ}C$)

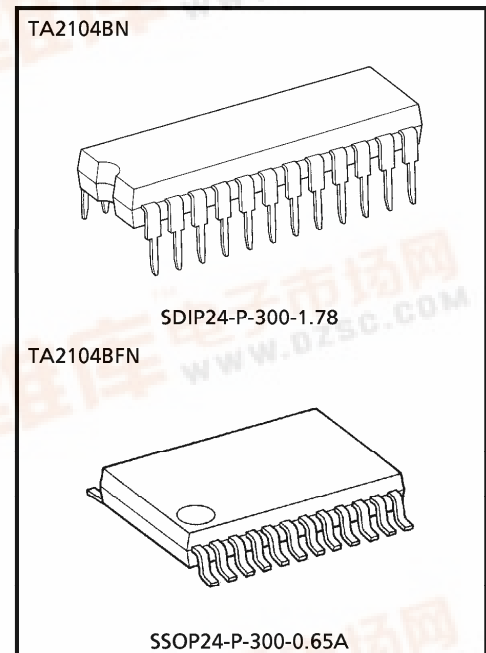

Weight
 SDIP24-P-300-1.78 : 1.2 g (Typ.)
 SSOP24-P-300-0.65A : 0.14 g (Typ.)

(*) Handle with care to prevent devices from deteriorations by static electricity.

980910EBA1

- TOSHIBA is continually working to improve the quality and the reliability of its products. Nevertheless, semiconductor devices in general can malfunction or fail due to their inherent electrical sensitivity and vulnerability to physical stress. It is the responsibility of the buyer, when utilizing TOSHIBA products, to observe standards of safety, and to avoid situations in which a malfunction or failure of a TOSHIBA product could cause loss of human life, bodily injury or damage to property. In developing your designs, please ensure that TOSHIBA products are used within specified operating ranges as set forth in the most recent products specifications. Also, please keep in mind the precautions and conditions set forth in the TOSHIBA Semiconductor Reliability Handbook.
- The products described in this document are subject to the foreign exchange and foreign trade laws.
- The information contained herein is presented only as a guide for the applications of our products. No responsibility is assumed by TOSHIBA CORPORATION for any infringements of intellectual property or other rights of the third parties which may result from its use. No license is granted by implication or otherwise under any intellectual property or other rights of TOSHIBA CORPORATION or others.
- The information contained herein is subject to change without notice.

BLOCK DIAGRAM

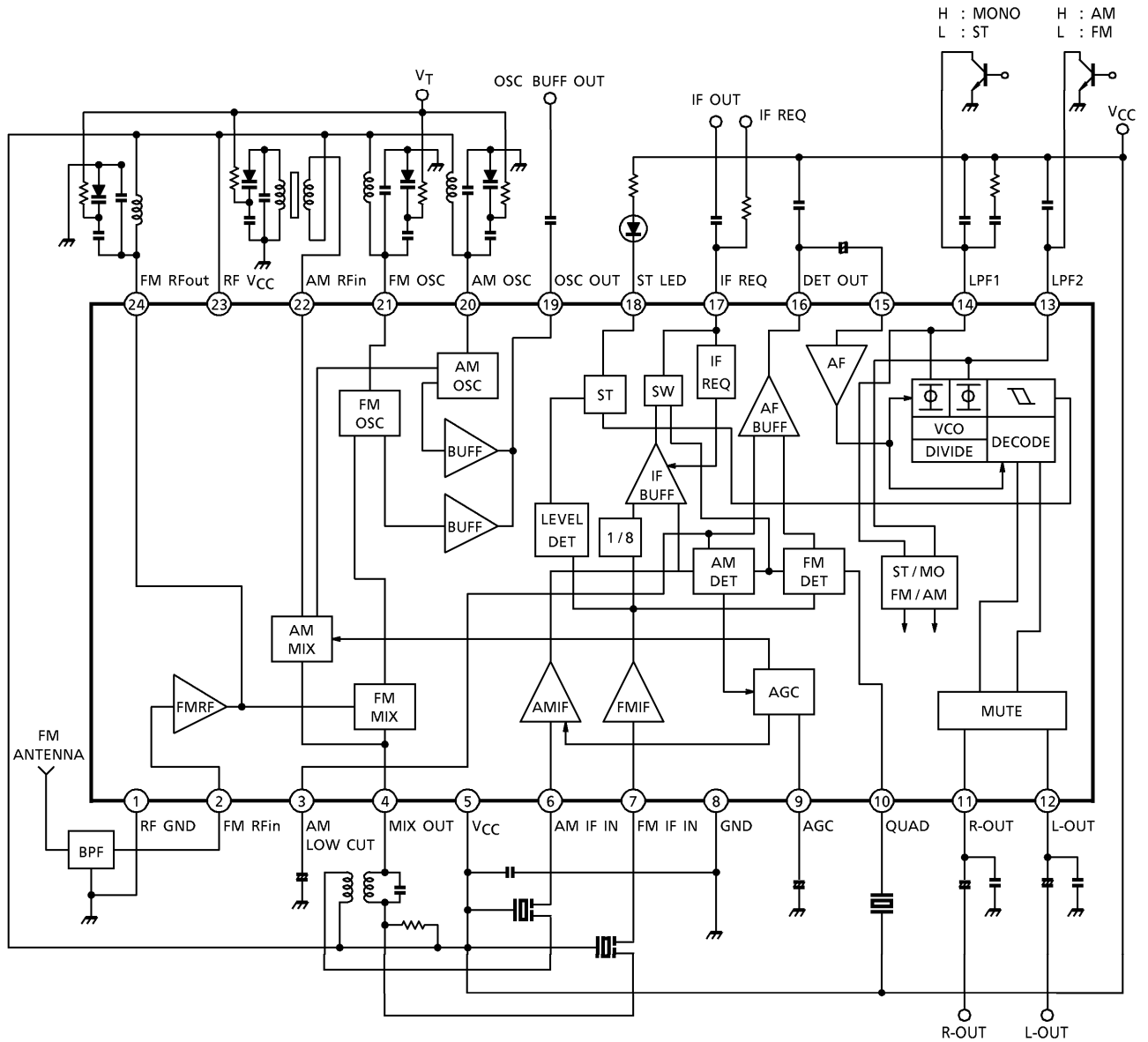

EXPLANATION OF TERMINALS

(Terminal Voltage : Typical terminal voltage at no signal with test circuit, $V_{CC} = 3\text{ V}$, $T_a = 25^\circ\text{C}$)

PIN No.	CHARACTERISTIC	INTERNAL CIRCUIT	TERMINAL VOLTAGE (Typ.) (V)	
			AM	FM
1	RF GND (GND for FM OSC stage)	—	0	0
2	FM-RFin		0	0.8
3	AM LOW CUT		1.0	—
4	MIX OUT		3.0	3.0
5	V_{CC} (V_{CC} for AM, FM IF, FM MPX stage)	—	3.0	3.0
6	AM IF IN		2.3	2.5
7	FM IF IN		3.0	3.0

PIN No.	CHARACTERISTIC	INTERNAL CIRCUIT	TERMINAL VOLTAGE (Typ.) (V)	
			AM	FM
8	GND (GND for AM, FM IF, FM MPX stage)	—	0	0
9	AGC		0	0
10	QUAD		2.5	2.2
11 12	R-OUT L-OUT		1.2	1.2
13	<p>LPF2</p> <ul style="list-style-type: none"> ● LPF terminal for phase Detector. ● Bias terminal AM / FM SW circuit. <p>V₁₃ = GND → AM V₁₃ = OPEN → FM</p>		0	2.2

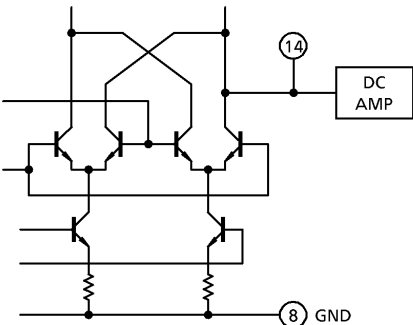
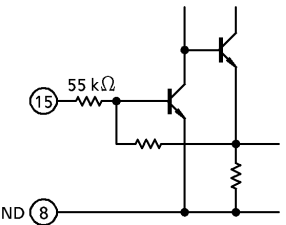
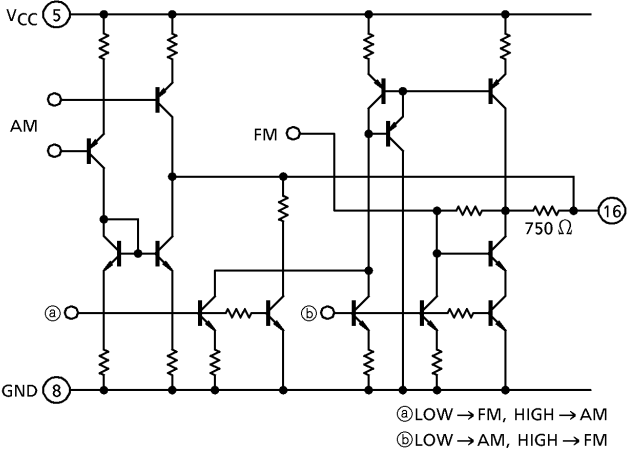
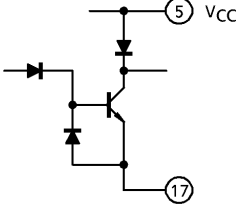
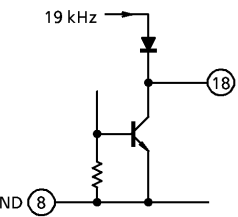
PIN No.	CHARACTERISTIC	INTERNAL CIRCUIT	TERMINAL VOLTAGE (Typ.) (V)	
			AM	FM
14	<p>LPF1</p> <ul style="list-style-type: none"> ● LPF terminal for Synchronous Detector. ● V_{CO} Stop terminal. <p>V₁₄ = GND → V_{CO} STOP</p>		0.7	2.4
15	MPX IN		0.7	0.7
16	DET OUT		1.0	0.9
17	IF REQ		—	—
18	ST LED		—	—

PIN No.	CHARACTERISTIC	INTERNAL CIRCUIT	TERMINAL VOLTAGE (Typ.) (V)	
			AM	FM
19	OSC OUT		2.8	2.7
20	AM OSC		3.0	3.0
21	FM OSC		3.0	3.0
22	AM RFin		3.0	3.0
23	RF VCC (VCC for FM OSC stage)	—	3.0	3.0
24	FM RFin	Cf. pin ①	3.0	3.0

APPLICATION NOTE

1. AM Low-Cut Circuit

- The AM Low-Cut action is carried out by the bypass of the high frequency component of the positive-feedback signal at the AF AMP stage. The external capacitor : C₃ by-pass this component.
- The cut-off frequency f_L is determined by the internal resistance 22 kΩ (Typ.) and the external capacitor C₃ as following ;

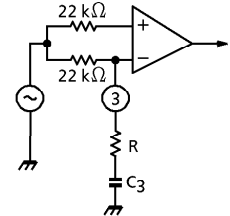

$$f_L = \frac{1}{2 \times \pi \times 22 \times 10^3 \times C_3} \text{ (Hz)}$$

- In the case of the AM Low-Cut function is not needed, set up the value of C₃ over 1 μF. In the condition of C₃ ≥ 1 μF, the frequency characteristic has flat response at the low frequency.
- It is possible to reduce the recovered output level at AM mode, by additional resistance between the pin ③ and GND line.

2. FM Detection Circuit

For the FM detection circuit, detection coil is able to use instead of ceramic discriminator. Recommended circuit and recommended coil are as follows. (In this case, please take care that V_{in} (lim.) falls a little.)

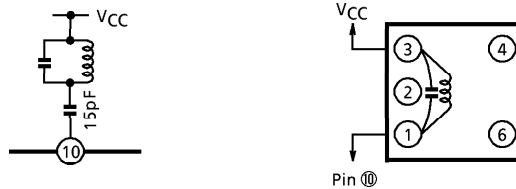

TEST FREQUENCY	C _o (pF)	Q _o	TURNS				WIRE (mm φ)	REFERENCE
			1-2	2-3	1-3	4-6		
10.7 MHz	51	45	—	—	30	—	0.08 UEW	TOKO Co., Ltd. 600BEAS-10018Z

3. FM/AM switch and forced monaural switch.

- FM/AM switchover and stereo/forced monaural switchover are done by pin ⑬ and pin ⑭.
- FM/AM switch (pin ⑬)
 - (V13 : Low (Active Low, V_{th} = 0.2 V (Typ.), I_{th} 30 μA (Typ.) → AM)
 - (V13 : OPEN → FM)
- Stereo/forced monaural switch (pin ⑭)
 - (V14 : Low (Active Low, V_{th} = 0.2 V (Typ.), I_{th} 30 μA (Typ.) → Forced Monaural)
 - (V14 : OPEN → Stereo)

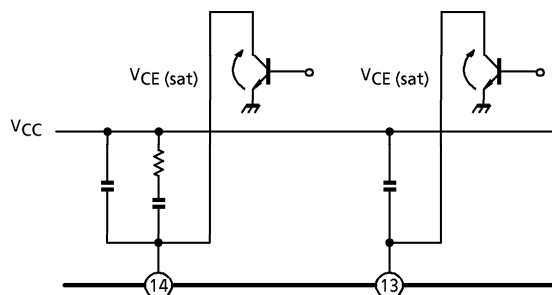

MAXIMUM RATINGS (Ta = 25°C)

CHARACTERISTIC	SYMBOL	RATING	UNIT	
Supply Voltage	V _{CC}	8	V	
LED Current	I _{LED}	10	mA	
LED Voltage	V _{LED}	8	V	
Power Dissipation	TA2104BN	P _D	1200	mW
	TA2104BFN	(Note)	500	
Operating Temperature	T _{opr}	- 25~75	°C	
Storage Temperature	T _{stg}	- 55~150	°C	

(Note) Derated above Ta = 25°C in the proportion of 9.6 mW/°C for TA2104BN of 4 mW/°C for TA2104BFN.

ELECTRICAL CHARACTERISTICS

Unless otherwise specified, Ta = 25°C, VCC = 3 V, F/E : f = 98 MHz, fm = 1 kHz
 FM IF : f = 10.7 MHz, Δf = ±75 kHz, fm = 1 kHz
 AM : f = 1 MHz, MOD = 30%, fm = 1 kHz
 MPX : fm = 1 kHz

CHARACTERISTIC		SYMBOL	TEST CIRCUIT	TEST CONDITION	MIN.	TYP.	MAX.	UNIT
Supply Current		ICC (FM)	—	Vin = 0, FM mode	—	11	14.5	mA
		ICC (AM)	—	Vin = 0, AM mode	—	7	9.5	
F/E	Input Limiting Voltage	Vin (lim)	—	Vin = 60 dBμV EMF, -3 dB limiting	—	12	—	dBμV EMF
	Local OSC Buffer Output Voltage	VOSC (buff) FM	—	fOSC = 108.7 MHz	23	35	—	mVrms
FM IF	Input Limiting Voltage	Vin (lim) IF	—	Vin = 80 dBμV EMF, -3 dB limiting	37	42	47	dBμV EMF
	Recovered Output Voltage	VOD	—	Vin = 80 dBμV EMF	200	250	300	mVrms
	Signal To Noise Ratio	S/N	—	Vin = 80 dBμV EMF	—	75	—	dB
	Total Harmonic Distortion	THD	—	Vin = 80 dBμV EMF	—	0.3	—	%
	AM Rejection Ration	AMR	—	Vin = 80 dBμV EMF	—	60	—	dB
	IF Count Output Frequency	fIF (FM)	—	Vin = 80 dBμV EMF, SW7 : ON	1.3373	1.3375	1.3377	MHz
	IF Count Output Voltage	VIF (FM)	—	Vin = 80 dBμV EMF, SW7 : ON	200	250	—	mVp-p
	IF Count Output Sensitivity	IF sens (FM)	—	SW7 : ON	41	46	51	dBμV EMF
AM	Gain	Gv	—	Vin = 27 dBμV EMF	20	38	70	mVrms
	Recovered Output Voltage	VOD	—	Vin = 60 dBμV EMF	60	85	108	mVrms
	Signal To Noise Ratio	S/N	—	Vin = 60 dBμV EMF	—	41	—	dB
	Total Harmonic Distortion	THD	—	Vin = 60 dBμV EMF	—	0.7	—	%
	Local OSC Buffer Output Voltage	VOSC (buff) AM	—	fOSC = 1.45 MHz	44	66	—	mVrms
	IF Count Output Voltage	VIF (AM)	—	Vin = 60 dBμV EMF, SW7 : ON	200	250	—	mVp-p
	IF Count Output Sensitivity	IF sens (AM)	—	SW7 : ON	38	43	48	dBμV EMF
PIN ⑰ Output Resistance		R17	—	FM mode	—	0.75	—	kΩ
				AM mode	—	15.5	—	

CHARACTERISTIC		SYMBOL	TEST CIR-CUIT	TEST CONDITION	MIN.	TYP.	MAX.	UNIT	
MPX	Input Resistance	R_{IN}	—	—	—	55	—	$k\Omega$	
	Output Resistance	R_{OUT}	—	—	—	5	—	$k\Omega$	
	Max. Composite Signal Input Voltage	$V_{in\ MAX}$ (Stereo)	—	L + R = 90%, P = 10%, SW3 : LPF ON $f_m = 1\ kHz$, THD = 3%	—	700	—	mV_{rms}	
	Separation	Sep.	—	L + R = 180 mV_{rms} , P = 20 mV_{rms} SW3 : LPF ON	$f_m = 100\ Hz$	—	45	—	dB
					$f_m = 1\ kHz$	35	45	—	
					$f_m = 10\ kHz$	—	45	—	
	Total Harmonic Distortion	Monaural	THD (Monaural)	—	$V_{in} = 200\ mV_{rms}$	—	0.3	—	%
		Stereo	THD (Stereo)	—	L + R = 180 mV_{rms} , P = 20 mV_{rms} , SW3 : LPF ON	—	0.3	—	
	Voltage Gain		G_V	—	$V_{in} = 200\ mV_{rms}$	-2.7	-1.2	0.2	dB
	Channel Balance		C.B.	—	$V_{in} = 200\ mV_{rms}$	-1.5	0	1.5	dB
	Stereo LED Sensitivity	ON	V_L (ON)	—	Pilot Input (19 kHz)	—	10	14	mV_{rms}
		OFF	V_L (OFF)	—		5	8	—	
	Stereo LED Hysteresis		V_H	—	To LED turn off from LED turn on	—	2	—	mV_{rms}
Capture Range		C.R.	—	P = 15 mV_{rms}	—	± 8	—	%	
Signal Noise Ratio		S/N	—	$V_{in} = 200\ mV_{rms}$	—	80	—	dB	
Muting Attenuation		MUTE	—	$V_{in} = 200\ mV_{rms}$	—	80	—	dB	

COIL DATA

COIL No.	TEST FREQ	L (μH)	Co (pF)	Qo	TURNS					WIRE (mm ϕ)	REFERENCE
					1-2	2-3	1-3	1-4	4-6		
L ₁ FM RF	100 MHz			79			2 $\frac{1}{2}$			0.16UEW	TOKO Co., Ltd. 666SNF-305NK
L ₂ FM OSC	100 MHz			76			2			0.16UEW	TOKO Co., Ltd. 666SNF-306NK
T ₁ AM OSC	796 kHz	268	—	65	19	95				0.05UEW	TOKO Co., Ltd. 5PNR-5146Y
T ₂ AM IFT	455 kHz	—	470	60			109		7	0.05UEW	TOKO Co., Ltd. 5PNR-5147X

L₁ : FM RF

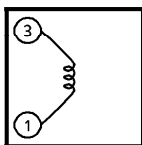

L₂ : FM OSC

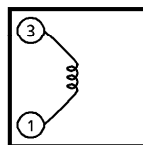

T₁ : AM OSC

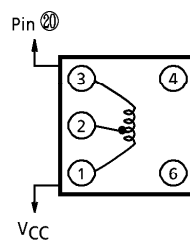

T₂ : AM IFT

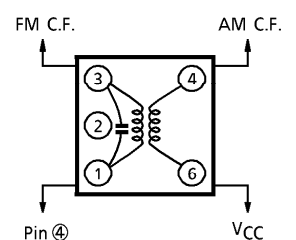

FMFE

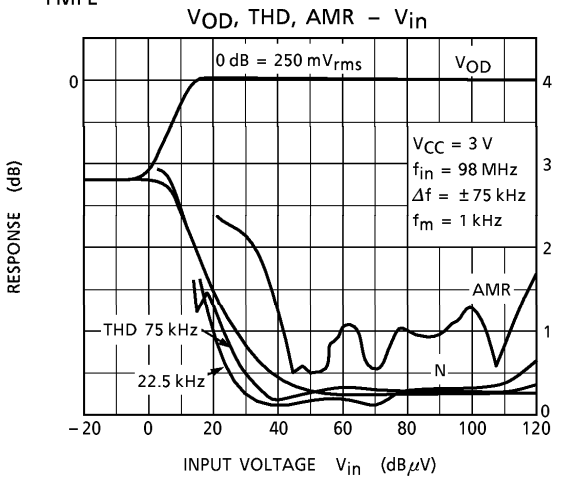

FM (IF)

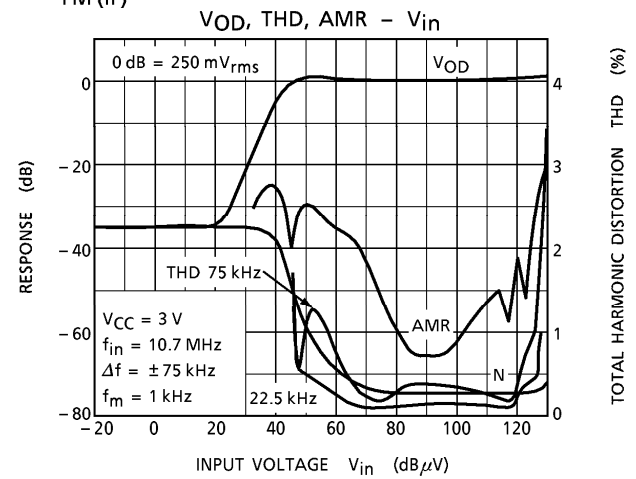

FM (IF)

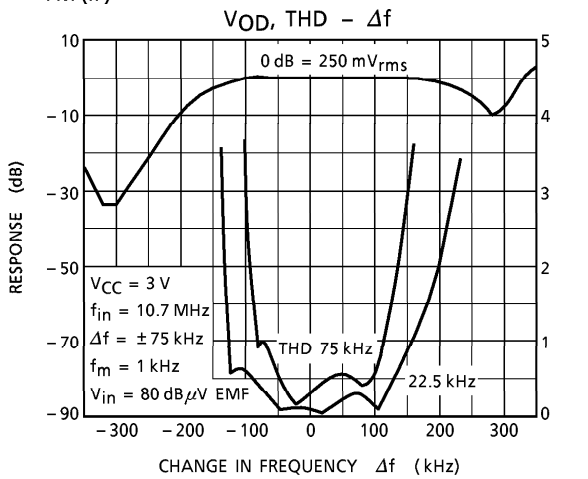

FM (IF)

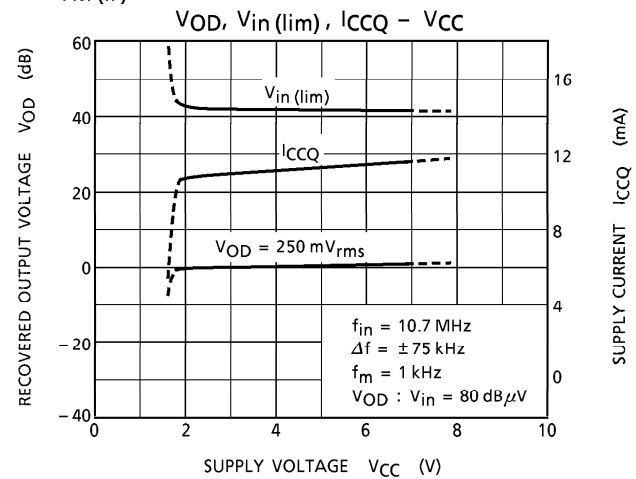

FM

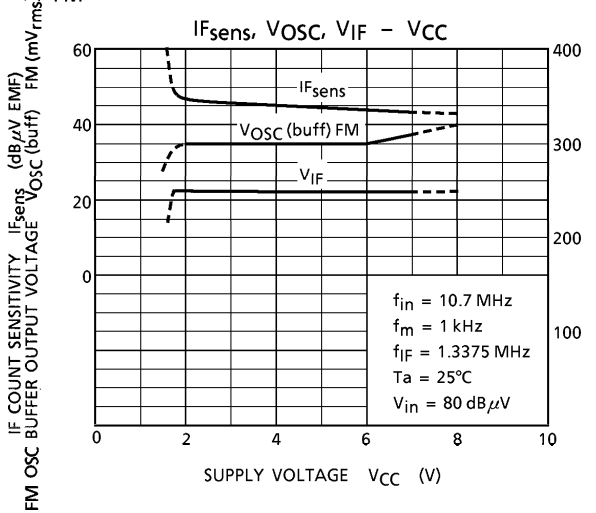

FM (IF)

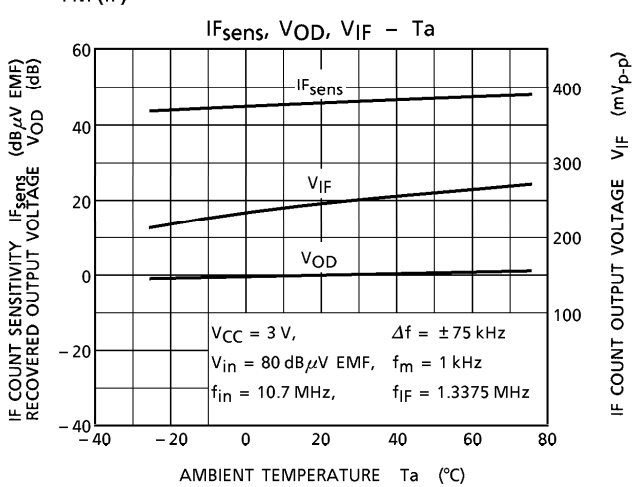

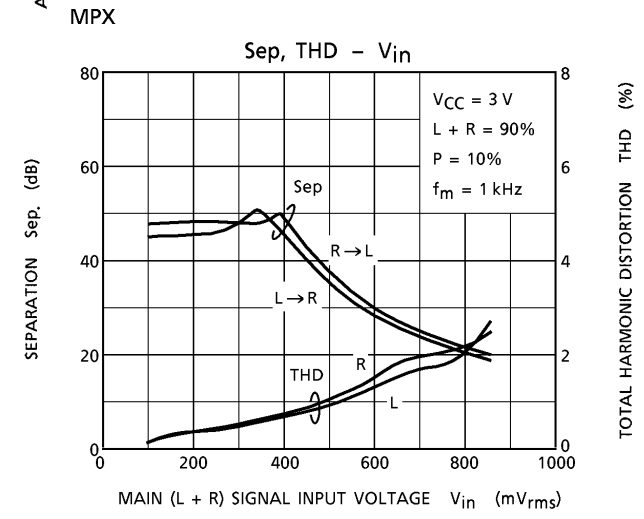
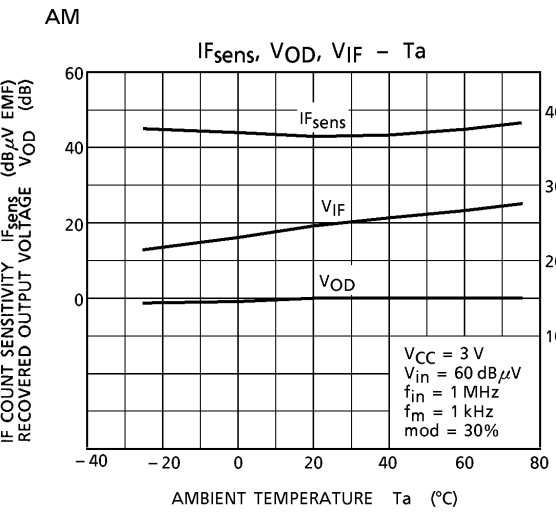
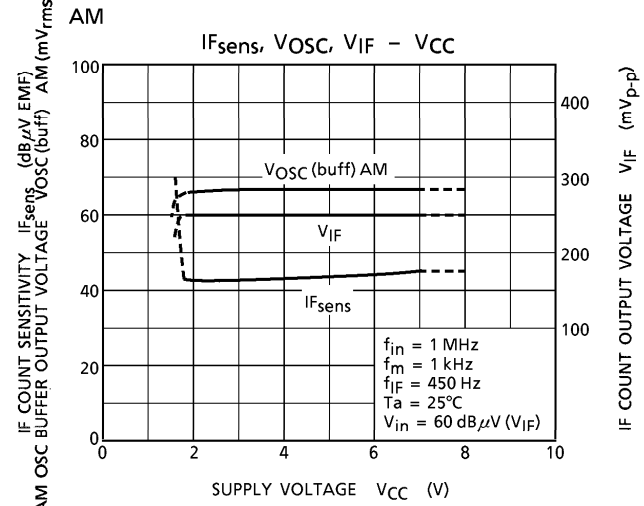
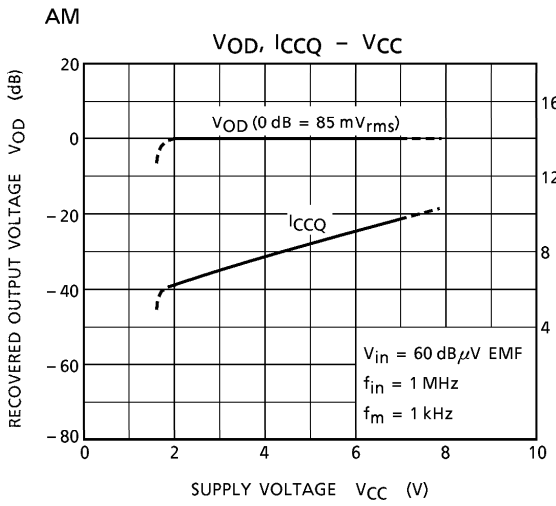
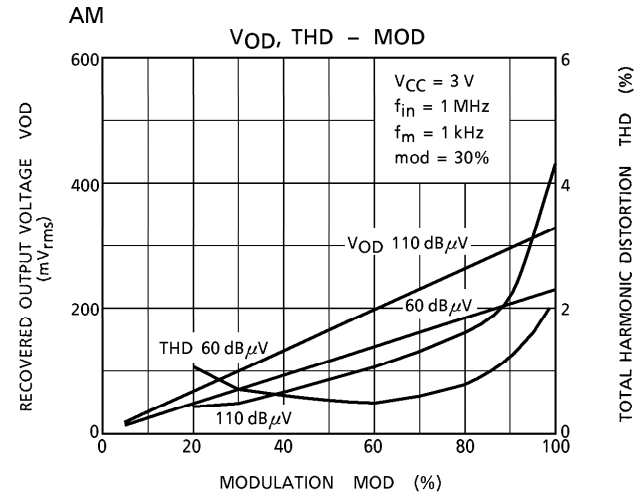
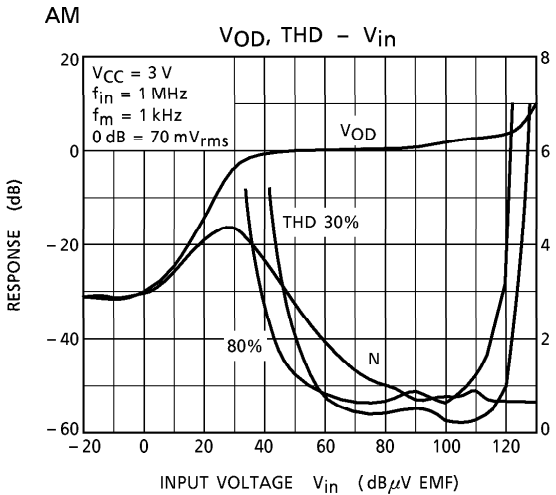

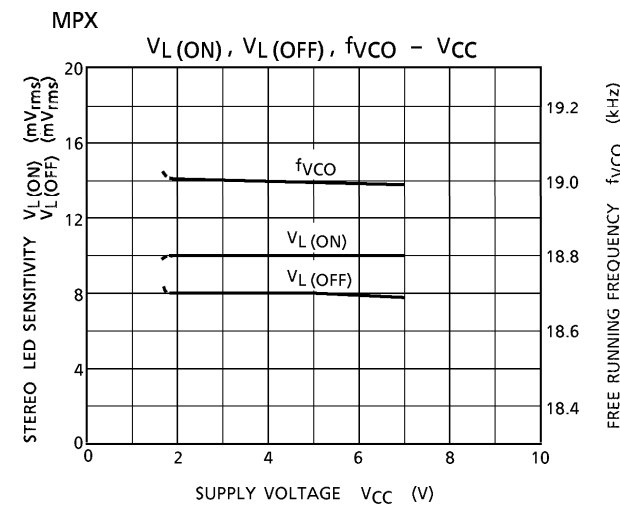
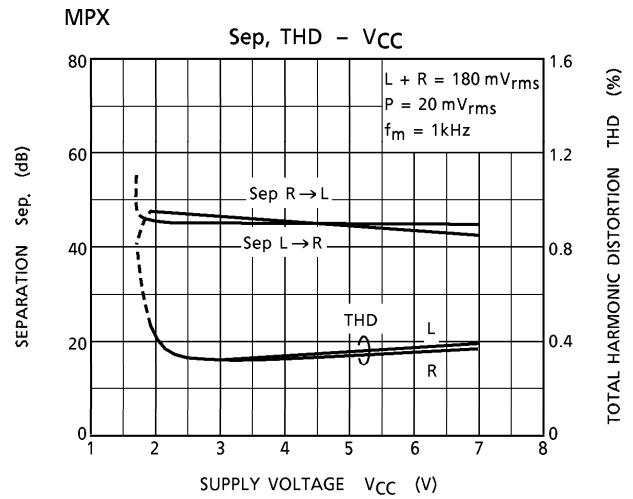
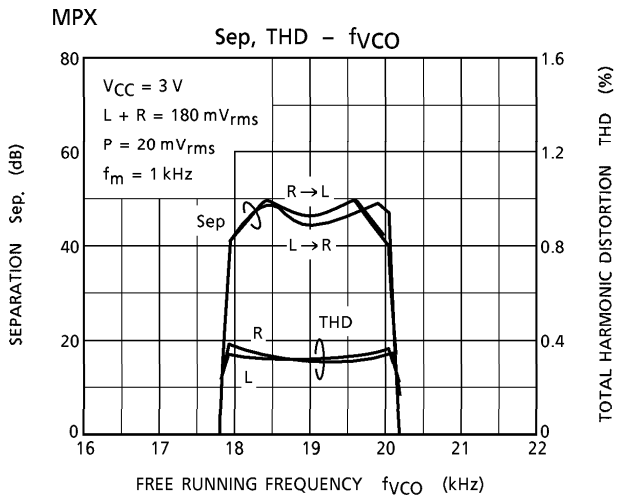
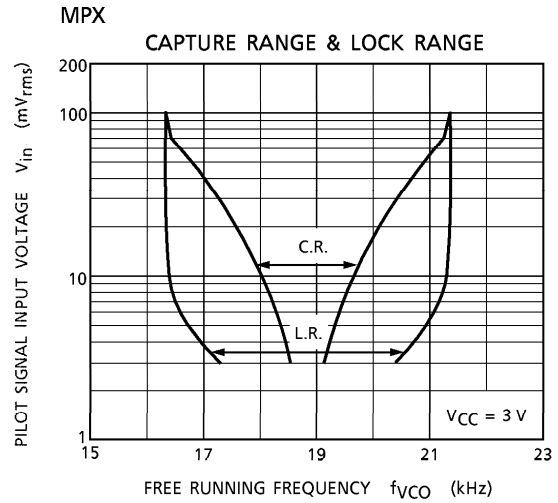
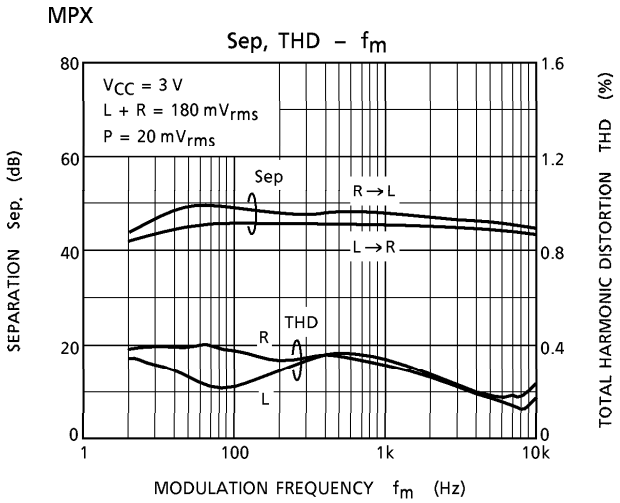

OUTLINE DRAWING
SDIP24-P-300-1.78

Unit : mm

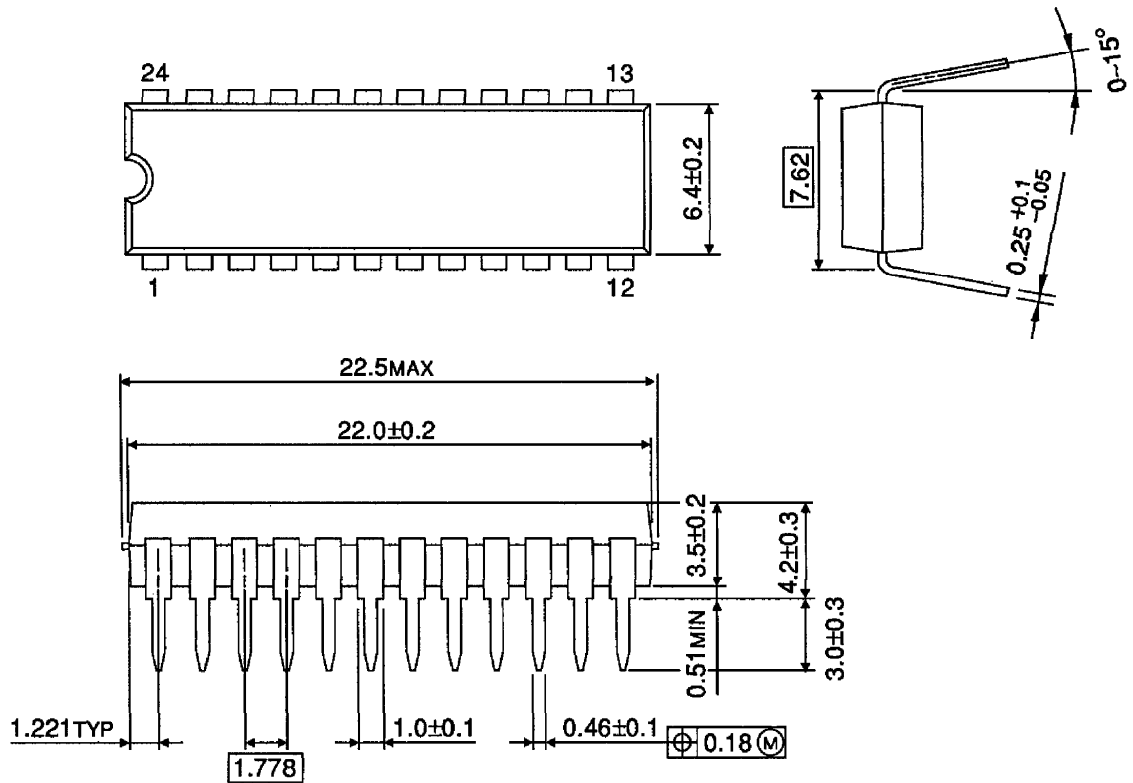

Weight : 1.2 g (Typ.)

OUTLINE DRAWING
SSOP24-P-300-0.65A

Unit : mm

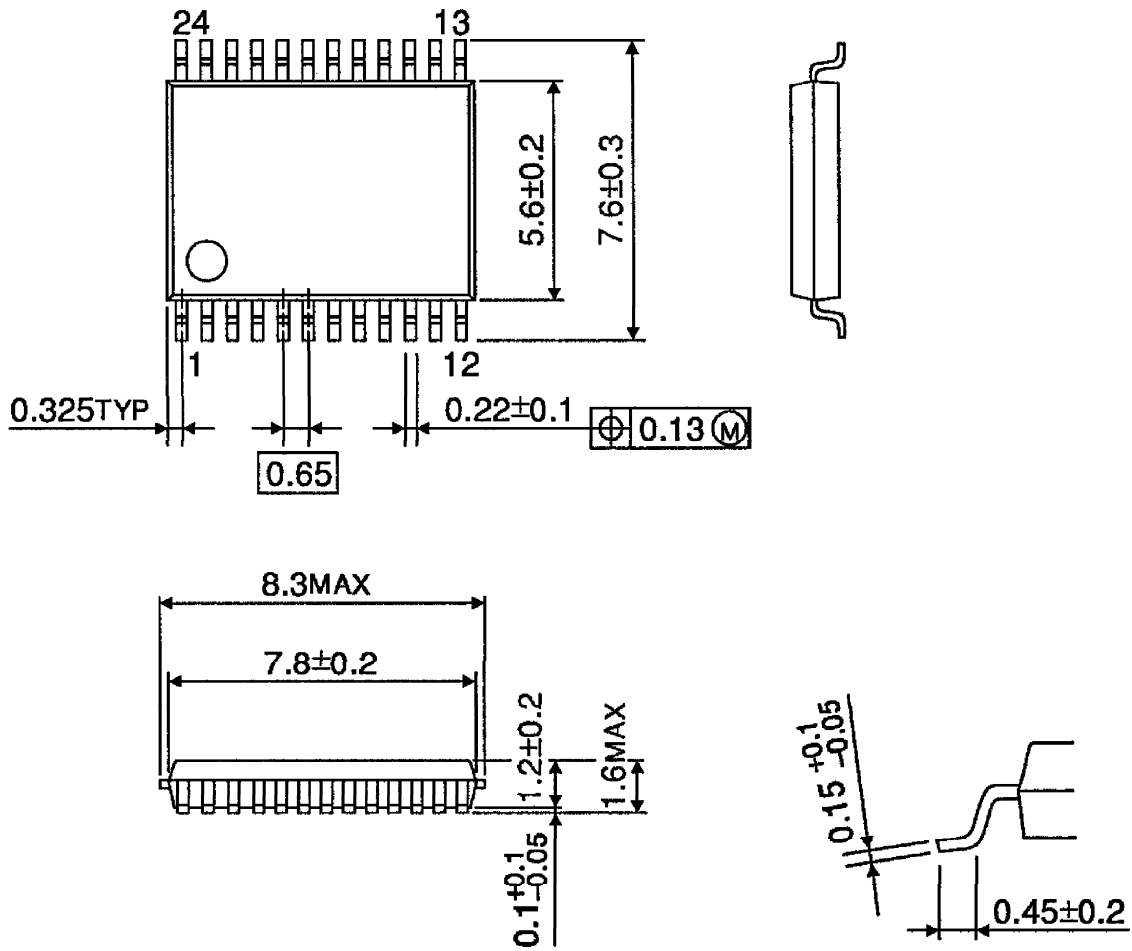

Weight : 0.14 g (Typ.)