

TOSHIBA BIPOLAR LINEAR INTEGRATED CIRCUIT SILICON MONOLITHIC

TA8126S, TA8126F

DC / DC CONVERTER FOR ELECTRIC TUNING (3V USE)

The TA8126S, TA8126F are DC / DC converter ICs, which are designed for biasing varactor diodes of tuner system. Those items are especially suitable for supplying high voltage (about 15V / 30V) for electric tuning (FM / TV / UHF / AM) system of headphone stereos, radio cassette recorders, or other equipments.

FEATURES

- Excellent regulatory capability of output voltage against fluctuation of supply voltage, and of ambient temperature.
- Excellent spurious radiation by oscillation of sine wave.
- Output voltage can be switched over to 15V or 30V by one-make switch, and is applicable to 10V, too.
- Few external parts.
- Low supply current (at non-load, $V_{CC} = 3V$, $T_a = 25^\circ C$)
 $I_{CCQ1} = 2.4mA$ (Typ., $V_O = 15V$ Mode)
 $I_{CCQ2} = 3.0mA$ (Typ., $V_O = 30V$ Mode)
- Operating supply voltage range ($T_a = 25^\circ C$)
 V_{CC1} (opr) = 1.8~10V, ($V_O = 15V$ Mode)
 V_{CC2} (opr) = 2.0~10V, ($V_O = 30V$ Mode)

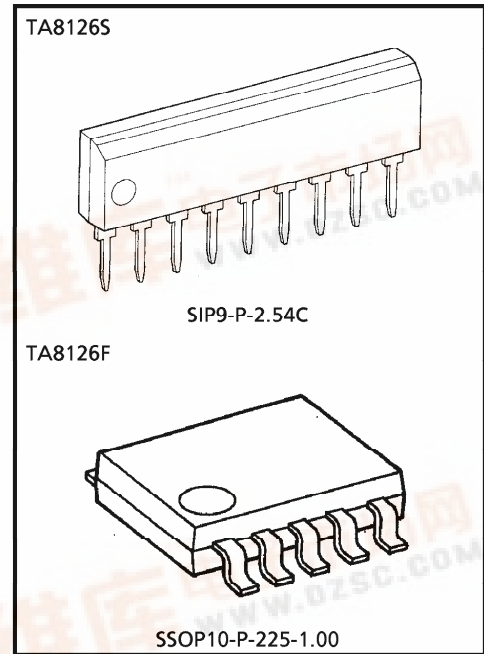

Weight	
SIP9-P-2.54C	: 0.72g (Typ.)
SSOP10-P-225-1.00	: 0.09g (Typ.)

BLOCK DIAGRAM

TA8126S

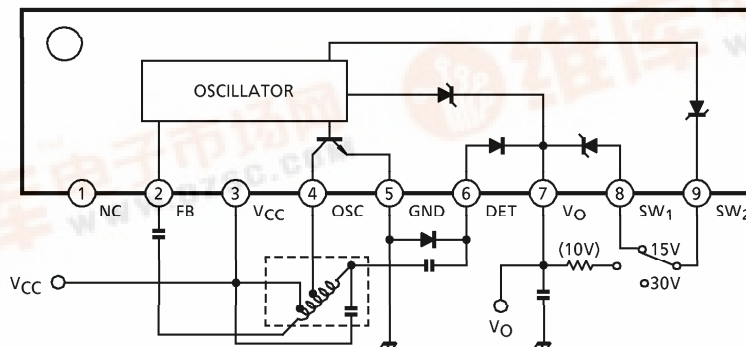

BLOCK DIAGRAM

TA8126F

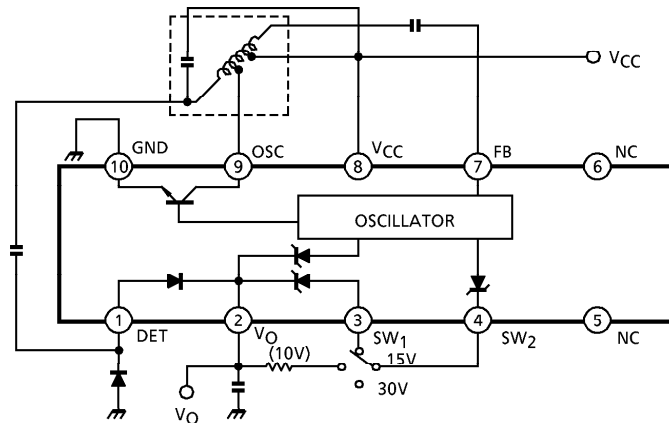

TERMINAL EXPLANATION

Terminal voltage : Typical terminal voltage with test circuit ($V_{CC} = 3V$, $T_a = 25^\circ C$)

PIN No. S/F	PIN NAME	CONTENTS	EQUIVALENT	TERMINAL VOLTAGE (V)
1 / 6	NC	—	—	—
2 / 7	FB	<ul style="list-style-type: none"> Hartley type oscillator $f_{OSC} = \frac{1}{2\pi\sqrt{L_3 C_2}}$		1.4
4 / 9	OSC	<ul style="list-style-type: none"> Controlling oscillation current at the terminal of FB 		3.0
3 / 8	V_{CC}	—	—	3.0
5 / 10	GND	—	—	0
6 / 1	DET	<ul style="list-style-type: none"> Boosted output (Voltage double rectifier) $V_O = 15V / 30V$ 		—
7 / 2	V_O			—
8 / 3	SW ₁	<ul style="list-style-type: none"> Output voltage mode switchover ON : $V_O = 15V$ OFF : $V_O = 30V$ 		—
9 / 4	SW ₂			—
- / 5	NC	—	—	—

961001EBA2'

● The products described in this document are subject to foreign exchange and foreign trade control laws.
 ● The information contained herein is presented only as a guide for the applications of our products. No responsibility is assumed by TOSHIBA CORPORATION for any infringements of intellectual property or other rights of the third parties which may result from its use. No license is granted by implication or otherwise under any intellectual property or other rights of TOSHIBA CORPORATION or others.
 ● The information contained herein is subject to change without notice.

APPLICATION NOTE

1. These ICs have the output voltage by means of boosting the oscillation voltage, derived from Hartley type oscillator circuit and of voltage-double rectifier with C₃, D₁ and D₂.

(1) Designing of oscillation frequency

$$f_{OSC} \doteq \frac{1}{2\pi \sqrt{L_3 C_2}}$$

(2) Coil turns can be designed as following :

$$V_{OSC (p-p)} = 2 (V_{CC (min)} - V_{CE1 (sat)})$$

$$n = \frac{n_3}{n_2} \doteq \frac{V_O}{V_{OSC (p-p)}}$$

(Note) V_{CC (min)} : Minimum of supply voltage designed by a equipment

V_{CE1 (sat)} : Saturation voltage of Q₁

n : Coil turns ratio (L₂, L₃)

V_O : Output voltage (V_O ≐ 30V)

The turn of L₁ is designed, so as to make the terminal of FB be about 200~300mV_{p-p} through C₁. The turn of L₁ should be small, and the capacitance of C₁ and Q₀ of coil should be large, for the oscillation start at turning power-on.

(3) Allowance is advisable for coil design of n, Q₀. However, spurious radiation can be reduced, in case that the output current and n of coil don't make large.

2. In case that spurious radiation due to the oscillation is large, it is recommended to provide LC filter on the power supply line as shown in Fig.2.

As for this value, select the optimum one depending on the kind of set.

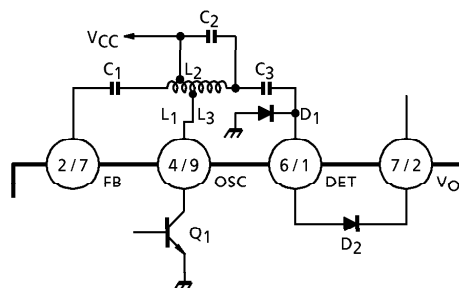

Fig.1 Oscillator and voltage-double

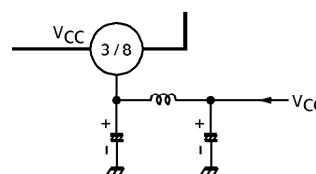

Fig.2 LC Filter

⊘ : TA8126S/F

3. Pattern diagram

The Fig.3 shows the oscillation loop. This pattern diagram should be small, because spurious radiation due to the oscillation is reduced. The Fig.4 shows the rectifier loop. This pattern diagram should be of the small, because spurious radiation due to the switching rectifier is reduced. The two loops should be isolated from other DC lines.

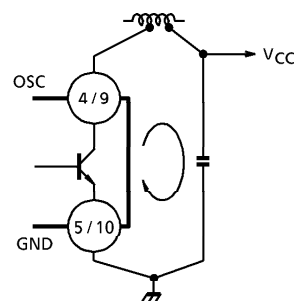

Fig.3 Oscillation loop

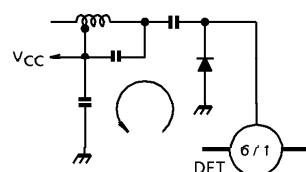

Fig.4 Rectifier loop

4. Output voltage application

The output voltage is applicable to about 10V, too, in case of connecting to external resistance " $R_x = 30k\Omega$ ", as Fig.5. But, in this application, the regulatory circuit doesn't operate, which is against fluctuation of supply voltage and of ambient temperature.

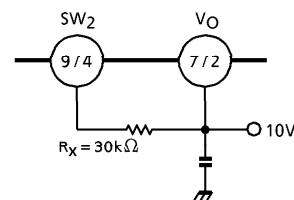

Fig.5 Output voltage application

 :TA8126S/F

MAXIMUM RATINGS (Ta = 25°C)

CHARACTERISTIC	SYMBOL	RATING	UNIT
Supply Voltage	V _{CC}	12	V
Output Voltage	V _O	35	V
Power Dissipation	TA8126S	P _D (Note)	mW
	TA8126F		
Operating Temperature	T _{opr}	- 25~75	°C
Storage Temperature	T _{stg}	- 55~150	°C

(Note) Derated above Ta = 25°C in the proportion of 6mW/°C for TA8126S, and of 3.2mW/°C for TA8126F.

ELECTRICAL CHARACTERISTICS

(Unless otherwise specified : $V_{CC} = 3V$, $T_a = 25^{\circ}C$, $f_{OSC} = 3.0MHz$, $I_O = 100\mu A$)

CHARACTERISTIC	SYMBOL	TEST CIRCUIT	SW MODE	TEST CONDITION	MIN.	TYP.	MAX.	UNIT
Supply Current	I_{CCQ1}	—	ON	$I_O = 0$	—	2.4	5	mA
	I_{CCQ2}	—	OFF	$I_O = 0$	—	3	6	
Boosted Output Voltage 1	V_{O1}	—	ON		14.0	15.1	16.0	V
V_{O1} Supply Voltage Fluctuation	ΔV_{O1}	—	ON	$V_{CC} = 10V \rightarrow 1.8V$	-20	0	20	mV
V_{O1} Ambient Temperature Coefficient	V_{O1}/T	—	ON	$T_a = -25 \sim 75^{\circ}C$	—	± 0.3	—	mV/ $^{\circ}C$
V_{O1} Maximum Output Current	I_{O1MAX}	—	ON	$\Delta V_{O1} = 30mV$, with respect to standard $I_O = 100\mu A$	300	—	—	μA
Boosted Output Voltage 2	V_{O2}	—	OFF		28.0	30.3	32.5	V
V_{O2} Supply Voltage Fluctuation	ΔV_{O2a}	—	OFF	$V_{CC} = 10V \rightarrow 2.5V$	-20	0	20	mV
	ΔV_{O2b}	—	OFF	$V_{CC} = 4.5V \rightarrow 2.0V$	-30	0	20	
V_{O2} Ambient Temperature Coefficient	V_{O2}/T	—	OFF	$T_a = -25 \sim 75^{\circ}C$	—	± 0.3	—	mV/ $^{\circ}C$
V_{O2} Maximum Output Current	I_{O2MAX}	—	OFF	$\Delta V_{O2} = 30mV$, with respect to standard $I_O = 100\mu A$	300	—	—	μA

TEST CIRCUIT

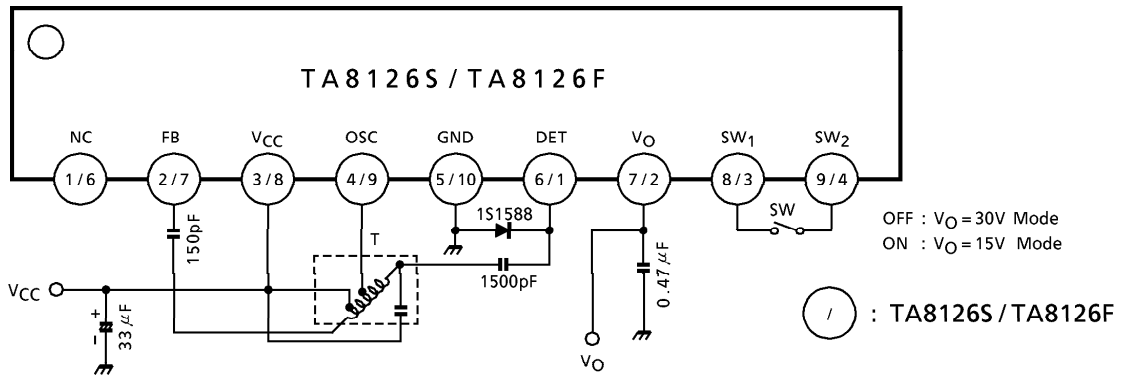

COIL DATA (Test circuit)

TEST FREQUENCY	L (µH)	Q ₀	C ₀ (pF)	TURN			WIRE (mmϕ)	REFERENCE
	2-6		4-6	1-2	2-3	1-6		
3MHz	103	40	22	7	2	57 $\frac{1}{2}$	0.1 UEW	Ⓢ 4143-3099-356

Ⓢ : SUMIDA ELECTRIC & Co., Ltd.

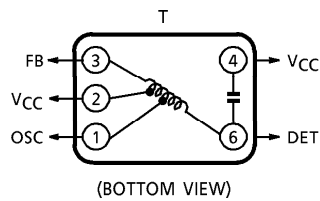

CHARACTERISTIC CURVES (Unless otherwise specified, $V_{CC} = 3V$, $T_a = 25^\circ C$, $f_{OSC} = 3MHz$, $I_O = 100\mu A$)

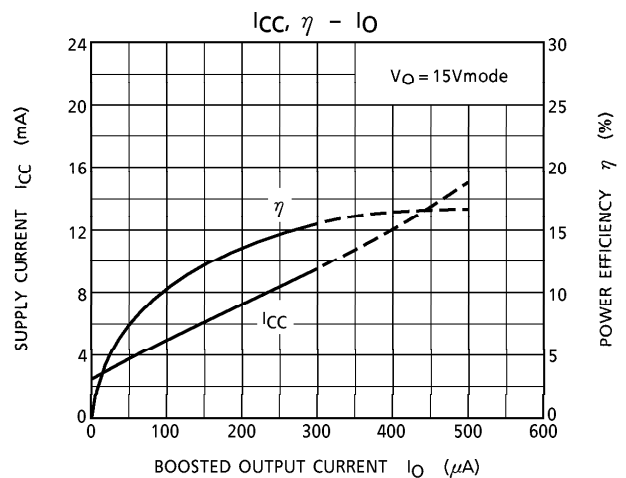
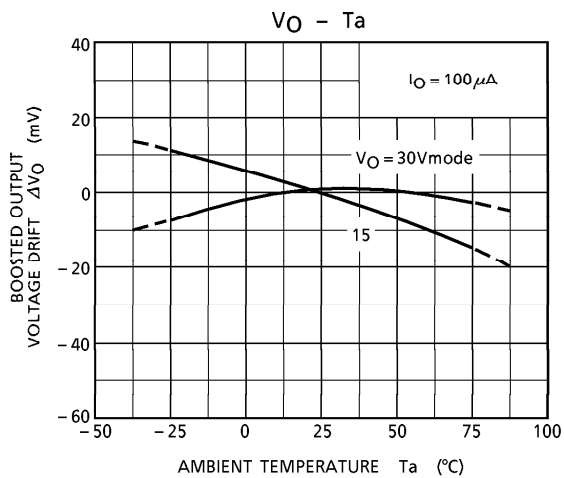
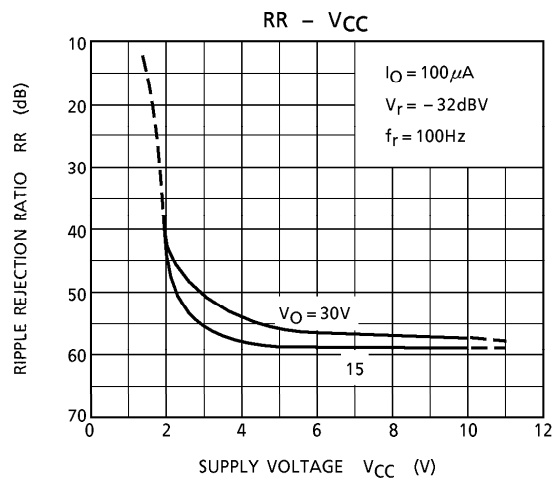
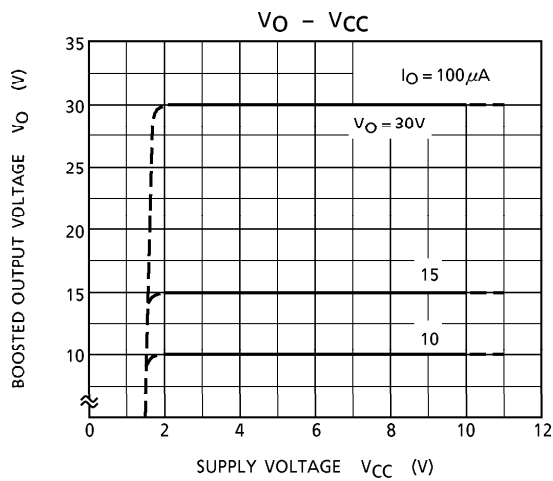
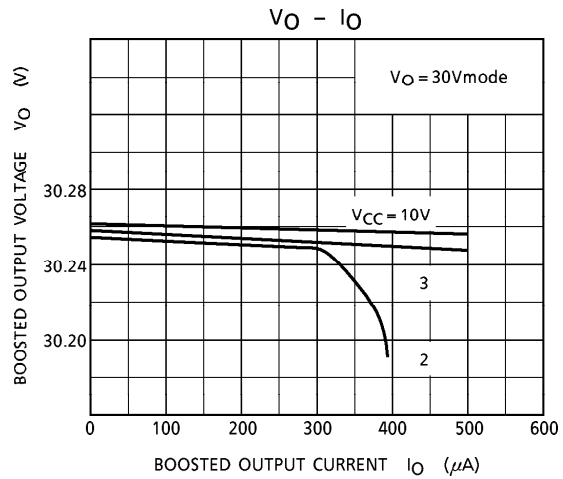
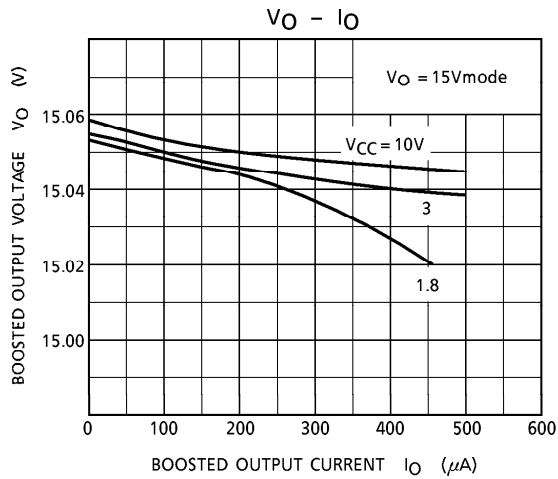

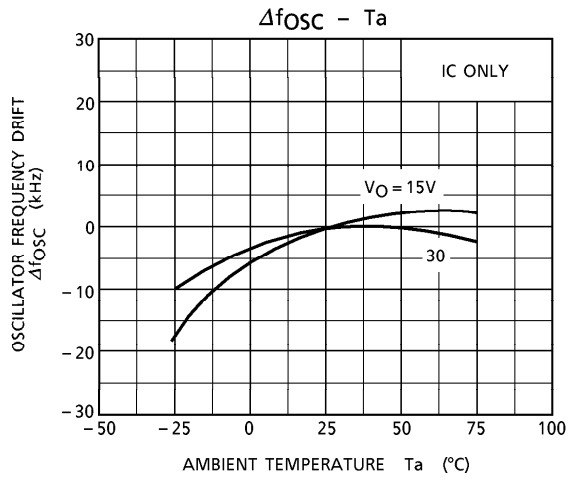
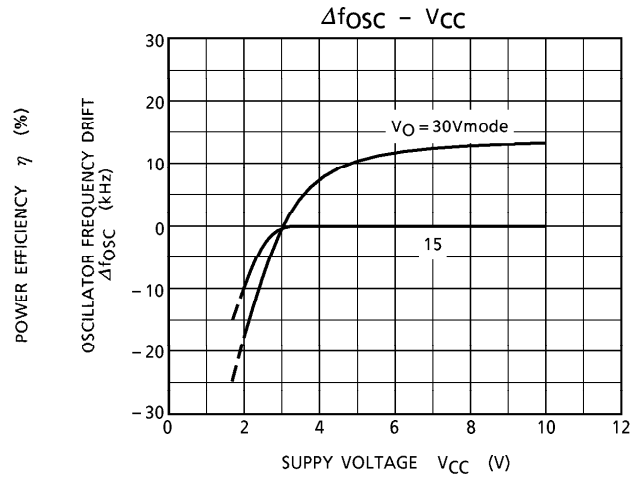
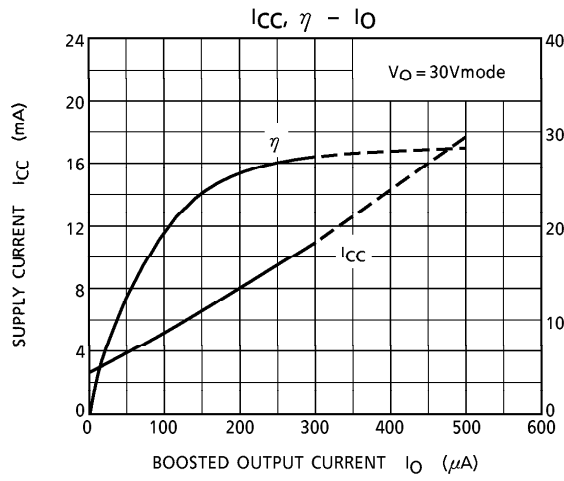

OUTLINE DRAWING
SIP9-P-2.54C

Unit : mm

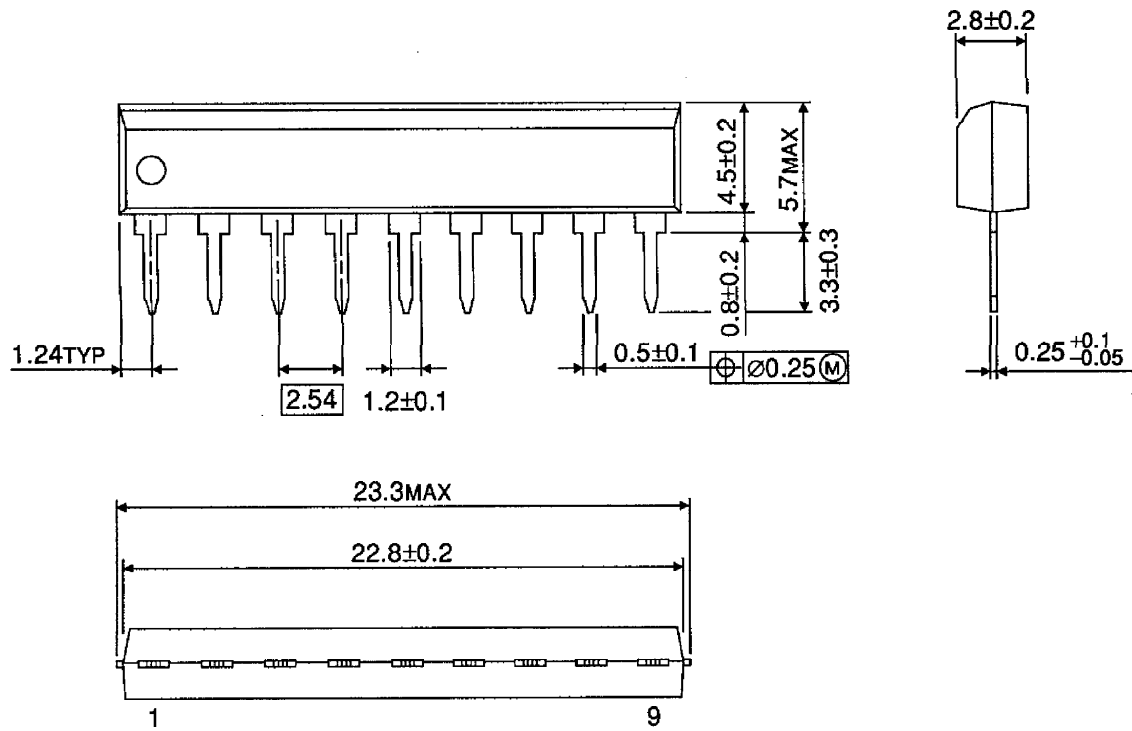

Weight : 0.72g (Typ.)

OUTLINE DRAWING
SSOP10-P-225-1.00

Unit : mm

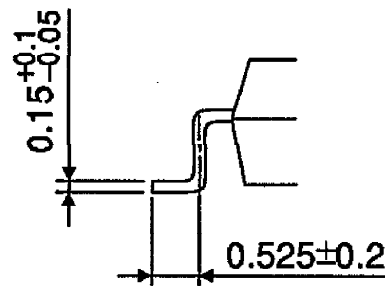
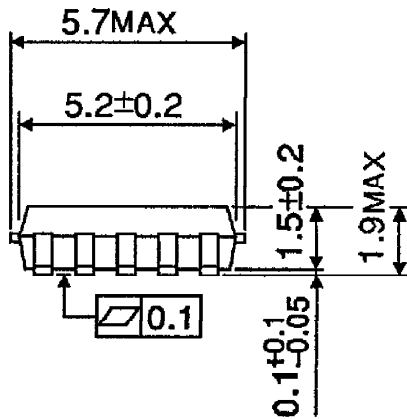
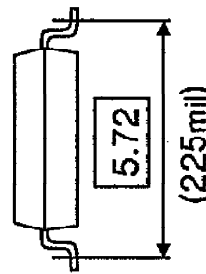
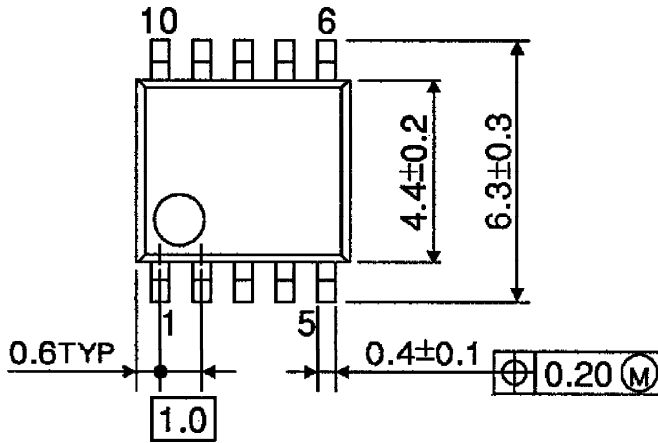

Weight : 0.09g (Typ.)