

TOSHIBA CCD LINEAR IMAGE SENSOR CCD(Charge Coupled Device)

# TCD132D

The TCD132D is a 1024-elements linear image sensor which includes CCD drive circuit and signal processing circuit. The CCD drive circuit consists of the pulse generator and the CCD driver; therefore it is possible to get easy drive by applying simple pulses ( $\phi_M$ ,  $\phi_{CCD}$  and SH).

The signal processing circuit which consists of the clamp circuit and S/H circuit and pre-amplifier.

**FEATURES**

- Number of Image Sensing Elements : 1024
- Image Sensing Element Size :  $14\mu\text{m}$  by  $14\mu\text{m}$  on  $14\mu\text{m}$  centers
- Photo Sensing Region : Low dark current pn photodiode
- Clock : 3 Input pulses 5V
- Internal Circuit : Clamp circuit (for optical black level reference)  
Sample & hold circuit  
Pre-amplifier
- Package : 22 pin cerdip

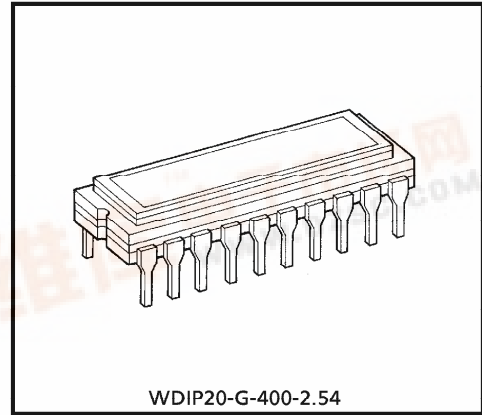

WDIP20-G-400-2.54

Weight : 3.1g (Typ.)

**MAXIMUM RATINGS (Note 1)**

CHARACTERISTIC	SYMBOL	RATING	UNIT
Master Clock Voltage	$V_{\phi M}$	- 0.3~15	V
CCD Clock Voltage	$V_{\phi CCD}$		V
Shift Pulse Voltage	$V_{SH}$		V
Reference Voltage	$V_{REF}$		V
Power Supply Voltage (Analog)	$V_{AD}$		V
Power Supply Voltage (Digital)	$V_{DD}$		V
Operating Temperature	$T_{opr}$	- 25~60	°C
Storage Temperature	$T_{stg}$	- 40~100	°C

(Note 1) All voltage are with respect to SS and  $V_{SS}$  terminals (Ground).

**PIN CONNECTIONS**

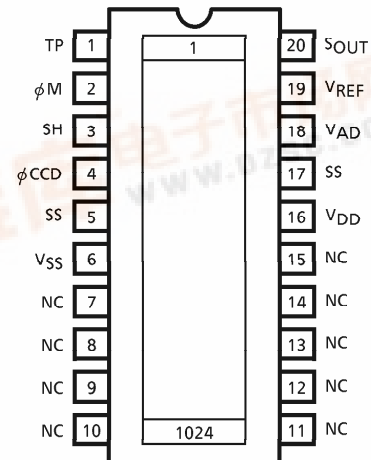

(TOP VIEW)

961001EBA2

● TOSHIBA is continually working to improve the quality and the reliability of its products. Nevertheless, semiconductor devices in general can malfunction or fail due to their inherent electrical sensitivity and vulnerability to physical stress. It is the responsibility of the buyer, when utilizing TOSHIBA products, to observe standards of safety, and to avoid situations in which a malfunction or failure of a TOSHIBA product could cause loss of human life, bodily injury or damage to property. In developing your designs, please ensure that TOSHIBA products are used within specified operating ranges as set forth in the most recent products specifications. Also, please keep in mind the precautions and conditions set forth in the TOSHIBA Semiconductor Reliability Handbook.

**CIRCUIT DIAGRAM**

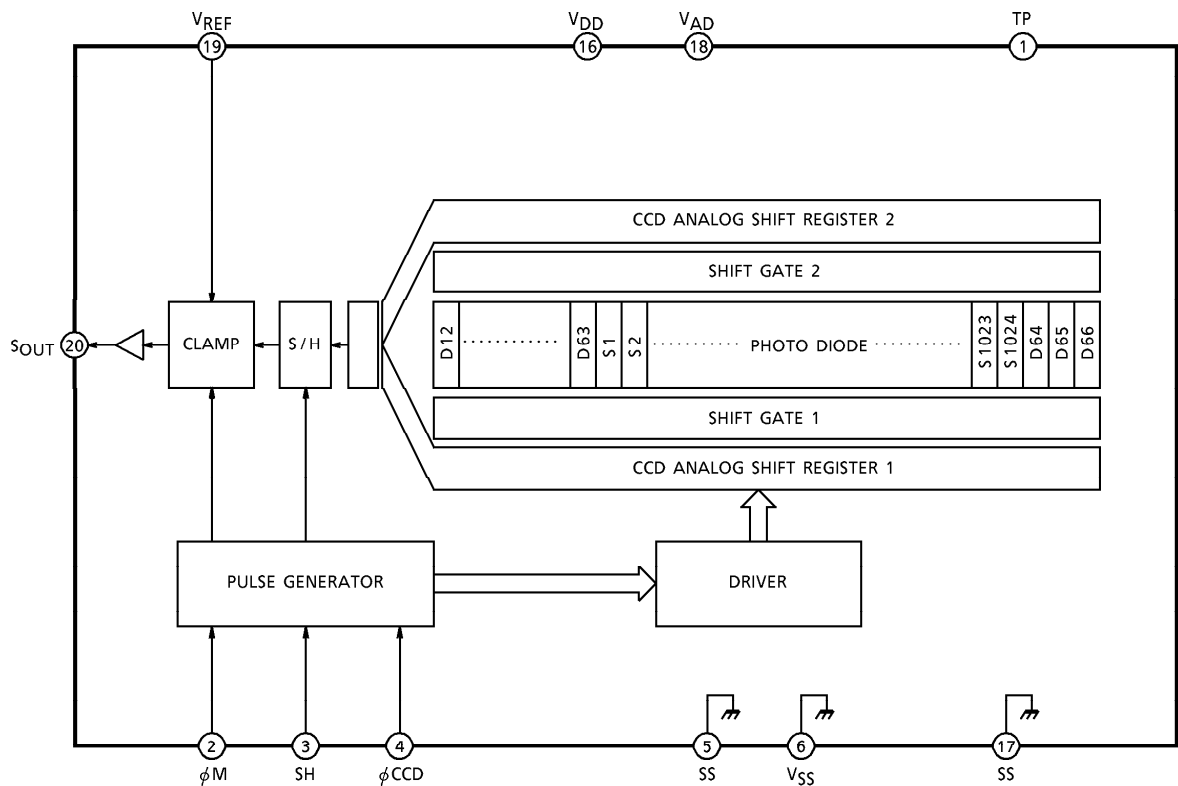

**PIN NAMES**

$\phi M$	Master Clock
$\phi CCD$	CCD Clock
SH	Shift Pulse
VREF	Reference Voltage Input
SOUT	Signal Output
VAD	Power (Analog)
VDD	Power (Digital)
SS	Ground (Analog)
VSS	Ground (Digital)
TP	Test Input
NC	Non Connection

● The products described in this document are subject to foreign exchange and foreign trade control laws.  
 ● The information contained herein is presented only as a guide for the applications of our products. No responsibility is assumed by TOSHIBA CORPORATION for any infringements of intellectual property or other rights of the third parties which may result from its use. No license is granted by implication or otherwise under any intellectual property or other rights of TOSHIBA CORPORATION or others.  
 ● The information contained herein is subject to change without notice.

**OPTICAL / ELECTRICAL CHARACTERISTICS**

(Ta = 25°C, VAD = VDD = 12V, VφM = VφCCD = VSH = 5V (PULSE), VREF = 5.0V, fφCCD = 0.5MHz, tINT (INTEGRATION TIME) = 10ms, LIGHT SOURCE = DAYLIGHT FLUORESCENT LAMP, LOAD RESISTANCE = 100kΩ)

CHARACTERISTIC	SYMBOL	MIN.	TYP.	MAX.	UNIT	NOTE
Sensitivity	R	9	12	15	V / lx·s	(Note 2)
Photo Response Non Uniformity	PRNU	—	—	10	%	(Note 3)
Saturation Output Voltage	V <sub>SAT</sub>	2	3	—	V	(Note 4)
Saturation Exposure	SE	0.13	0.25	—	lx·s	(Note 5)
Dark Signal Non Uniformity	DSNU	—	—	15	mV	(Note 6)
Analog Current Dissipation	I <sub>AD</sub>	—	12	20	mA	
Digital Current Dissipation	I <sub>DD</sub>	—	4	10	mA	
Input Current of VREF	I <sub>REF</sub>	—	0.1	1	mA	
Total Transfer Efficiency	TTE	92	—	—	%	
Output Impedance	Z <sub>O</sub>	—	1	2	kΩ	
Clamp Error Voltage	V <sub>ERR</sub>	—	100	200	V	(Note 7)

(Note 2) Sensitivity for 2856K W-lamp is 25V / lx·s (Typ.)

(Note 3) Measured at 50% of SE (Typ.)

$$\text{Definition of PRNU : PRNU} = \frac{\Delta x}{\bar{x}} \times 100 (\%)$$

Where  $\bar{x}$  is average of total signal outputs and  $\Delta x$  is the maximum deviation from  $\bar{x}$  under uniform illumination.

(Note 4) V<sub>SAT</sub> is defined as minimum saturation output voltage of all effective pixels.

$$\text{(Note 5) Definition of SE : SE} = \frac{V_{SAT}}{R} \text{ (lx·s)}$$

(Note 6) Definition of DSNU : DSNU = MAX – MIN (mV)



(Note 7) Definition of  $V_{ERR}$  :  $V_{ERR} = |V_{REF} - V_{SIG}|$   
Where  $V_{SIG}$  is defined below.

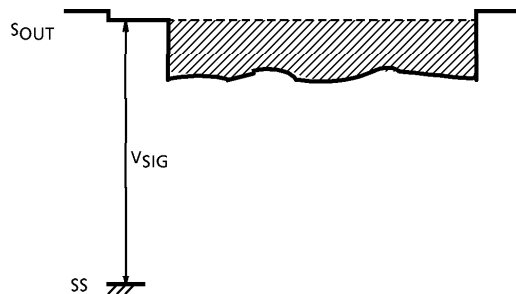

## OPERATING CONDITION

CHARACTERISTIC		SYMBOL	MIN.	TYP.	MAX.	UNIT
Master Clock Voltage	"H" Level	$V_{\phi M}$	4.5	5.0	5.5	V
	"L" Level		0	0.5	0.8	
CCD Clock Voltage	"H" Level	$V_{\phi CCD}$	4.5	5.0	5.5	V
	"L" Level		0	0.5	0.8	
Shift Pulse Voltage	"H" Level	$V_{SH}$	4.5	5.0	5.5	V
	"L" Level		0	0.5	0.8	
Reference Voltage		$V_{REF}$	4.5	5.0	5.5	V
Power Supply Voltage (Analog)		$V_{AD}$	11	12	13	V
Power Supply Voltage ((Driver)		$V_{DD}$	11	12	13	V
Test Input Voltage		$V_{TP}$	0	0	0.8	V

## CLOCK CHARACTERISTICS (Ta = 25°C)

CHARACTERISTIC	SYMBOL	MIN.	TYP.	MAX.	UNIT
Master Clock Frequency	$f_{\phi M}$	0.4	2	4	MHz
Data Rate	$f_{DATA}$	0.2	1	2	MHz
CCD Clock Frequency	$f_{\phi CCD}$	0.1	0.5	1.0	MHz
Master Clock Capacitance	$C_{\phi M}$	—	—	10	pF
CCD Clock Capacitance	$C_{\phi CCD}$	—	—	10	pF
Shift Pulse Capacitance	$C_{SH}$	—	—	10	pF

TIMING CHART

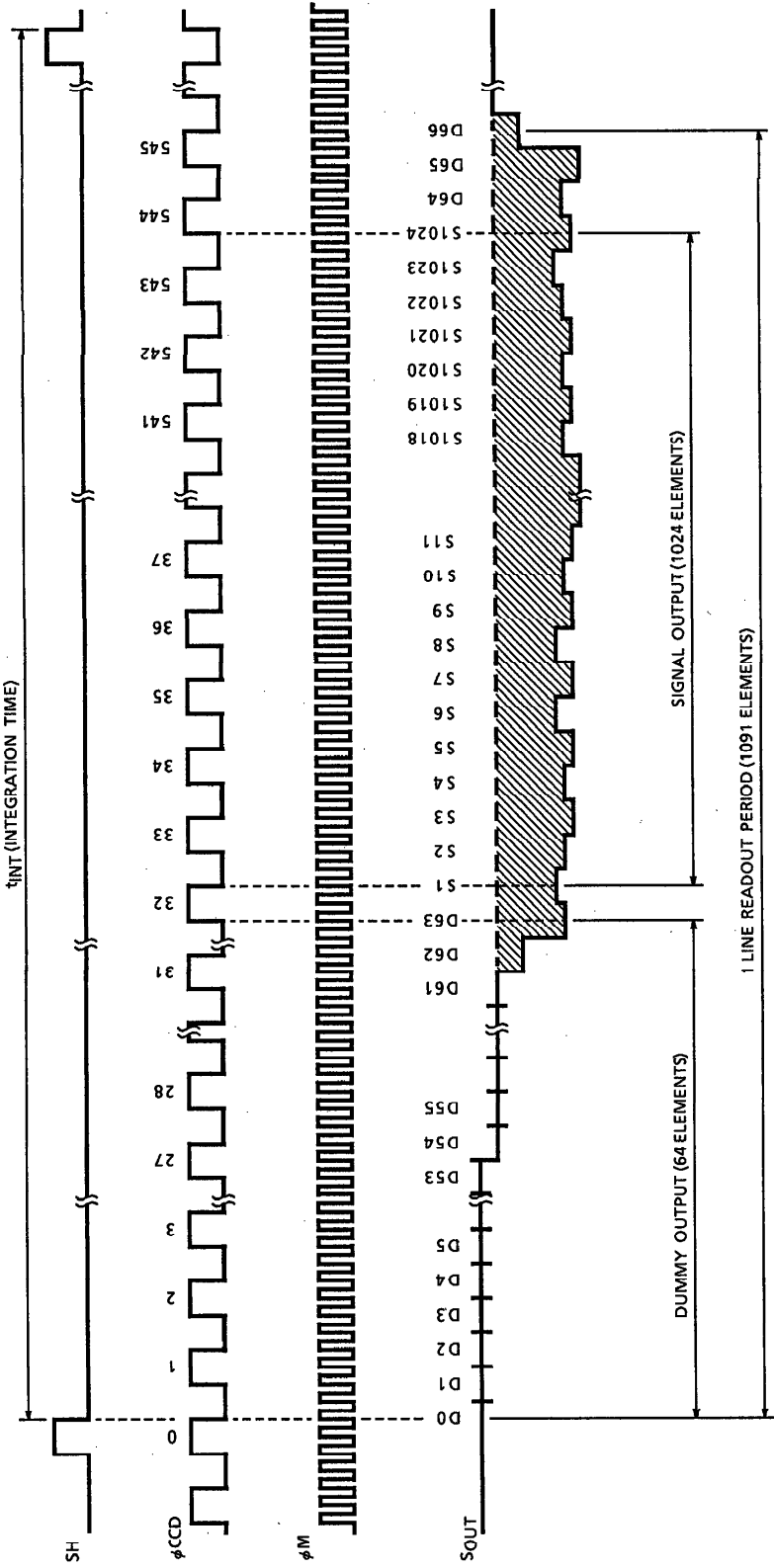

**TIMING REQUIREMENTS**

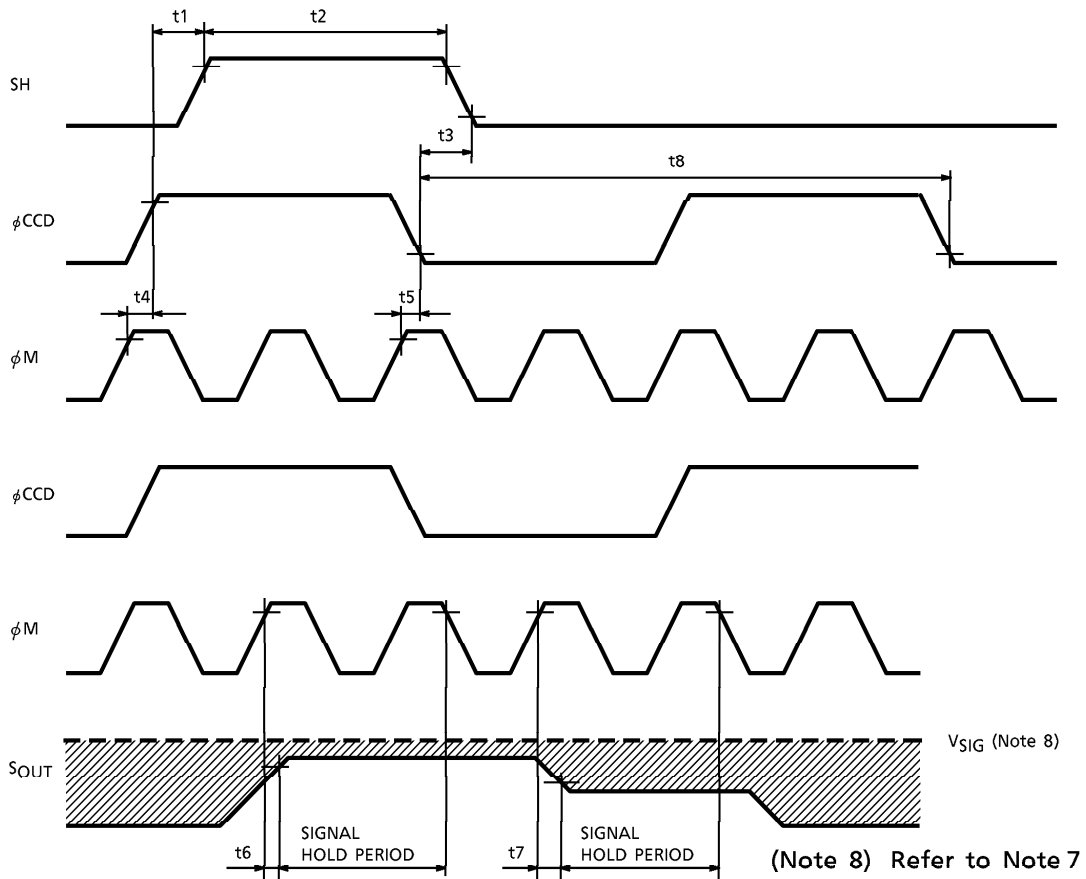

CHARACTERISTIC	SYMBOL	MIN.	TYP.	MAX.	UNIT
Pulse Timing of SH and $\phi_{CCD}$	$t_1, t_3$	0	20	60	ns
SH Pulse Width	$t_2$	250	—	$t_8 / 2$	ns
Pulse Timing of $\phi_M$ and $\phi_{CCD}$	$t_4, t_5$	0	20	60	ns
Aperture Delay	$t_6, t_7$	—	80	120	ns
$\phi_{CCD}$ Period	$t_8$	1	2	10	$\mu s$

**TYPICAL PERFORMANCE CURVES**

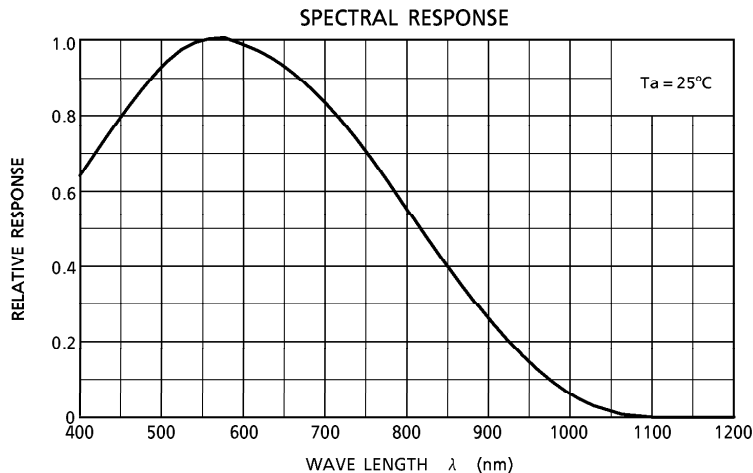

**MODULATION TRANSFER FUNCTION OF X-DIRECTION**

SPATIAL FREQUENCY (Cycles/mm)

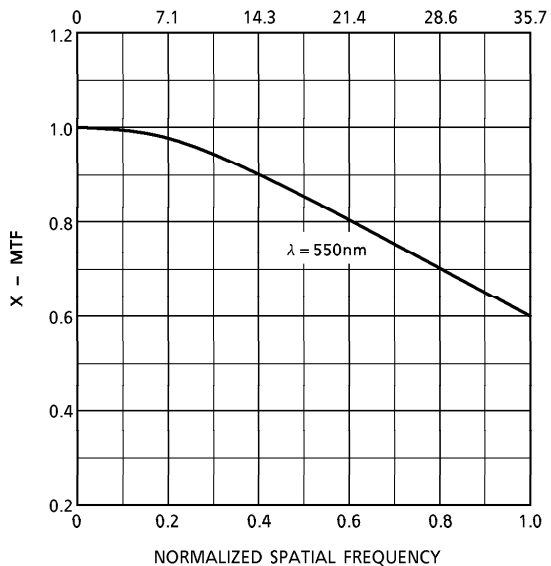

**MODULATION TRANSFER FUNCTION OF Y-DIRECTION**

SPATIAL FREQUENCY (Cycles/mm)

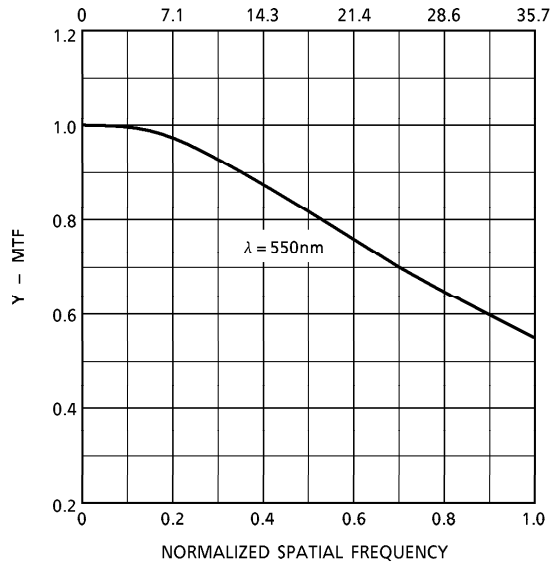



TYPICAL PERFORMANCE CURVES (Cont'd)

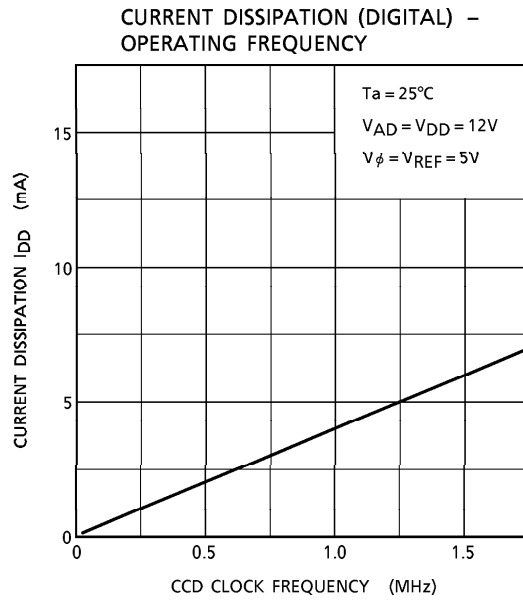
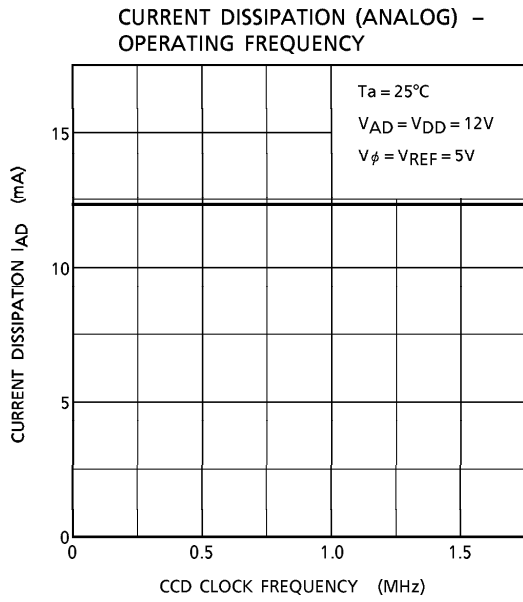

EXAMPLE OF OPERATING CIRCUIT

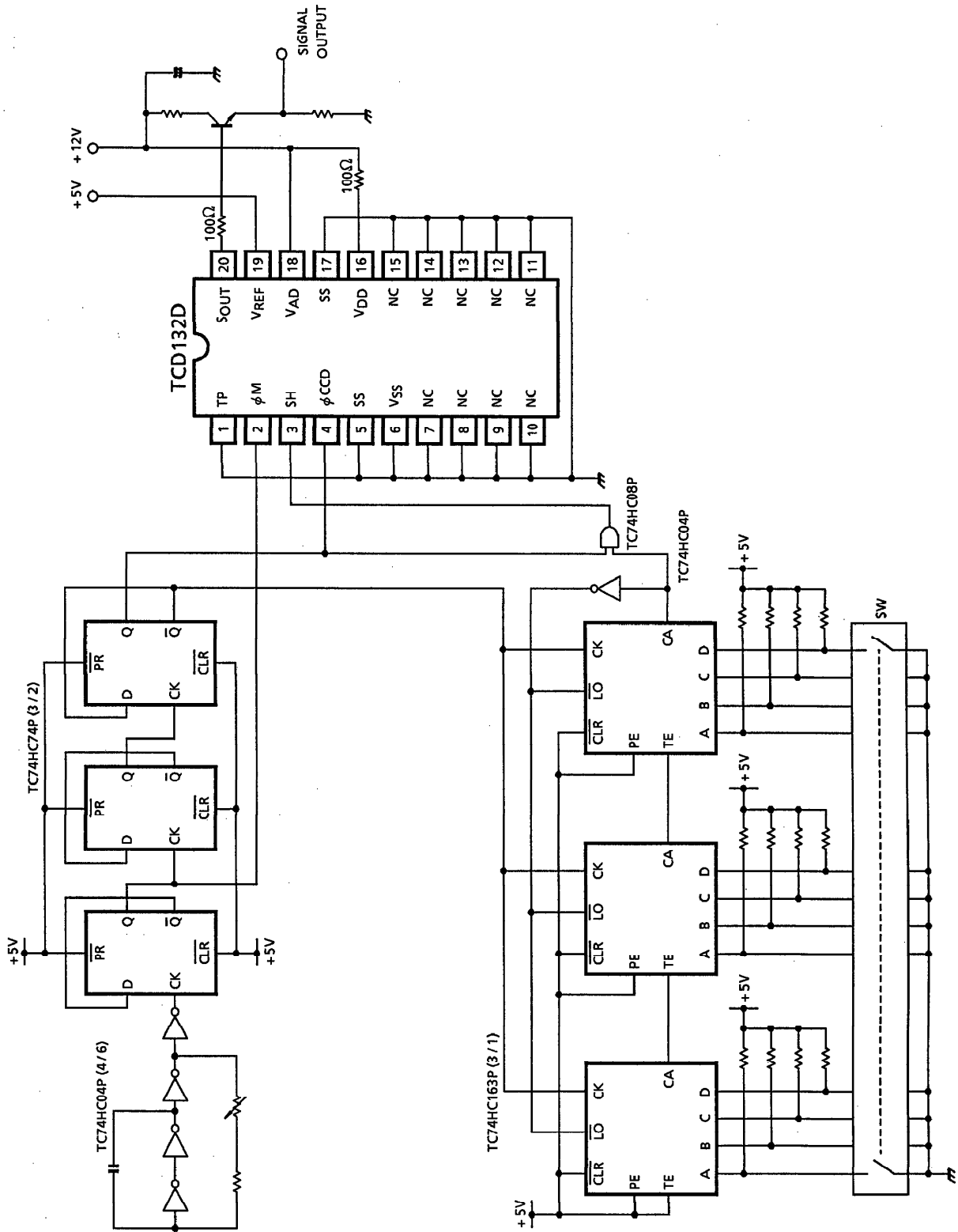

**CAUTION****1. Window Glass**

The dust and stain on the glass window of the package degrade optical performance of CCD sensor.

Keep the glass window clean by saturating a cotton swab in alcohol and lightly wiping the surface, and allow the glass to dry, by blowing with filtered dry N<sub>2</sub>.

Care should be taken to avoid mechanical or thermal shock because the glass window is easily to damage.

**2. Electrostatic Breakdown**

Store in shorting clip or in conductive foam to avoid electrostatic breakdown.

**3. Incident Light**

CCD sensor is sensitive to infrared light.

Note that infrared light component degrades resolution and PRNU of CCD sensor.

**4. Lead Frame Forming**

Since this package is not stout against mechanical stress, you should not reform the lead frame.

We recommend to use a IC-inserter when you assemble to PCB.

**OUTLINE DRAWING**

WDIP20-G-400 (B)

Unit : mm

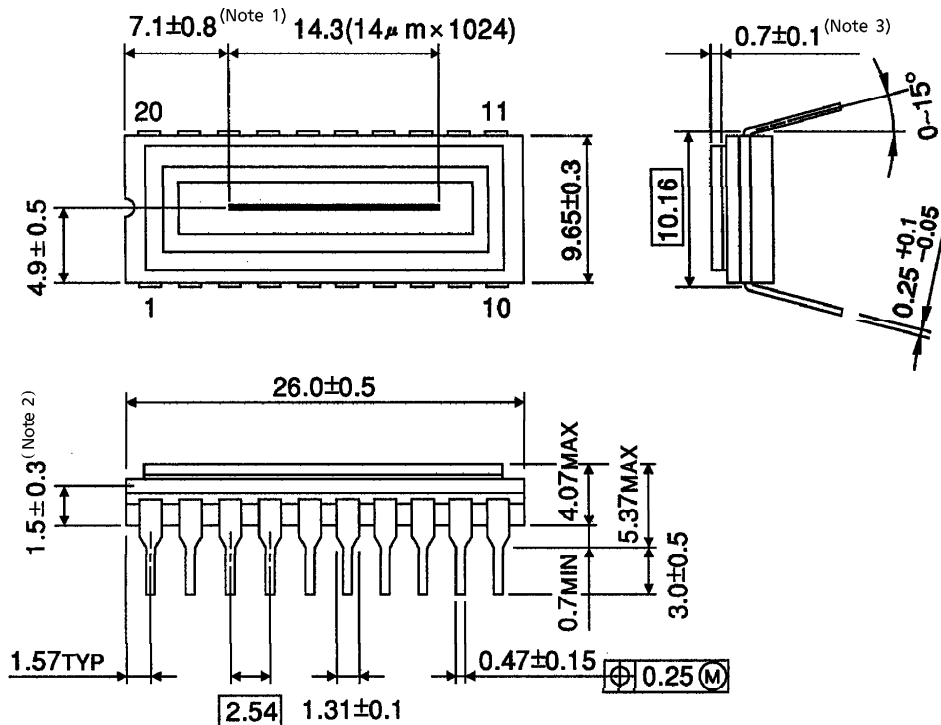

(Note 1) No. 1 SENSOR ELEMENT (S1) TO EDGE OF PACKAGE.

(Note 2) TOP OF CHIP TO BOTTOM OF PACKAGE.

(Note 3) GLASS THICKNES (n = 1.5)

Weight : 3.1g (Typ.)