

TFP201, TFP201A TI PanelBus™ DIGITAL RECEIVER

SLDS116A - MARCH 2000 – REVISED JUNE 2000

- Supports SXGA Resolution (Output Pixel Rates Up to 112 MHz)
- Digital Visual Interface (DVI) Specification Compliant¹
- True-Color, 24 Bit/Pixel, 16.7M Colors at 1 or 2-Pixels Per Clock
- Laser Trimmed Internal Termination Resistors for Optimum Fixed Impedance Matching
- Skew Tolerant Up to One Pixel Clock Cycle
- 4x Over-Sampling
- Reduced Power Consumption – 1.8 V Core Operation With 3.3 V I/Os and Supplies²
- Reduced Ground Bounce Using Time Staggered Pixel Outputs
- Lowest Noise and Best Power Dissipation Using TI PowerPAD™ Packaging
- Advanced Technology Using TI 0.18-μm EPIC-5™ CMOS Process
- TFP201A Incorporates HSYNC Jitter Immunity³

description

The Texas Instruments TFP201 and TFP201A are TI *PanelBus*™ flat panel display products, part of a comprehensive family of end-to-end DVI 1.0 compliant solutions. Targeted primarily at desktop LCD monitors and digital projectors, the TFP201/201A finds applications in any design requiring high-speed digital interface.

The TFP201/201A supports display resolutions up to SXGA in 24-bit true color pixel format. The TFP201/201A offers design flexibility to drive one or two pixels per clock, supports TFT or DSTN panels, and provides an option for time staggered pixel outputs for reduced ground bounce.

PowerPAD™ advanced packaging technology results in best of class power dissipation, footprint, and ultra-low ground inductance.

The TFP201/201A combines *PanelBus*™ circuit innovation with TI's advanced 0.18-μm EPIC-5™ CMOS process technology, along with TI PowerPAD™ package technology to achieve a reliable, low-powered, low noise, high-speed digital interface solution.

AVAILABLE OPTIONS

| T _A | PACKAGED DEVICE |
|----------------|-----------------|
| | |
| 0°C to 70°C | TFP201PZP |
| | TFP201APZP |



Please be aware that an important notice concerning availability, standard warranty, and use in critical applications of Texas Instruments semiconductor products and disclaimers thereto appears at the end of this data sheet.

1. The Digital Visual Interface Specification, DVI, is an industry standard developed by the Digital Display Working Group (DDWG) for high-speed digital connection to digital displays. The TFP201 and TFP201A are compliant to the DVI Specification Rev. 1.0.
2. The TFP201/201A has an internal voltage regulator that provides the 1.8-V core power supply from the externally supplied 3.3-V supplies.
3. The TFP201A incorporates additional circuitry to create a stable HSYNC from DVI transmitters that introduce undesirable jitter on the transmitted HSYNC signal.

PanelBus, PowerPAD and EPIC-5 are trademarks of Texas Instruments. DVI is a licensed bus protocol from Phillips Semiconductor, Inc.

PRODUCTION DATA information is current as of publication date. Products conform to specifications per the terms of Texas Instruments standard warranty. Production processing does not necessarily include testing of all parameters.



TFP201, TFP201A TI PanelBus™ DIGITAL RECEIVER

SLDS116A - MARCH 2000 – REVISED JUNE 2000

100-PIN PACKAGE (TOP VIEW)

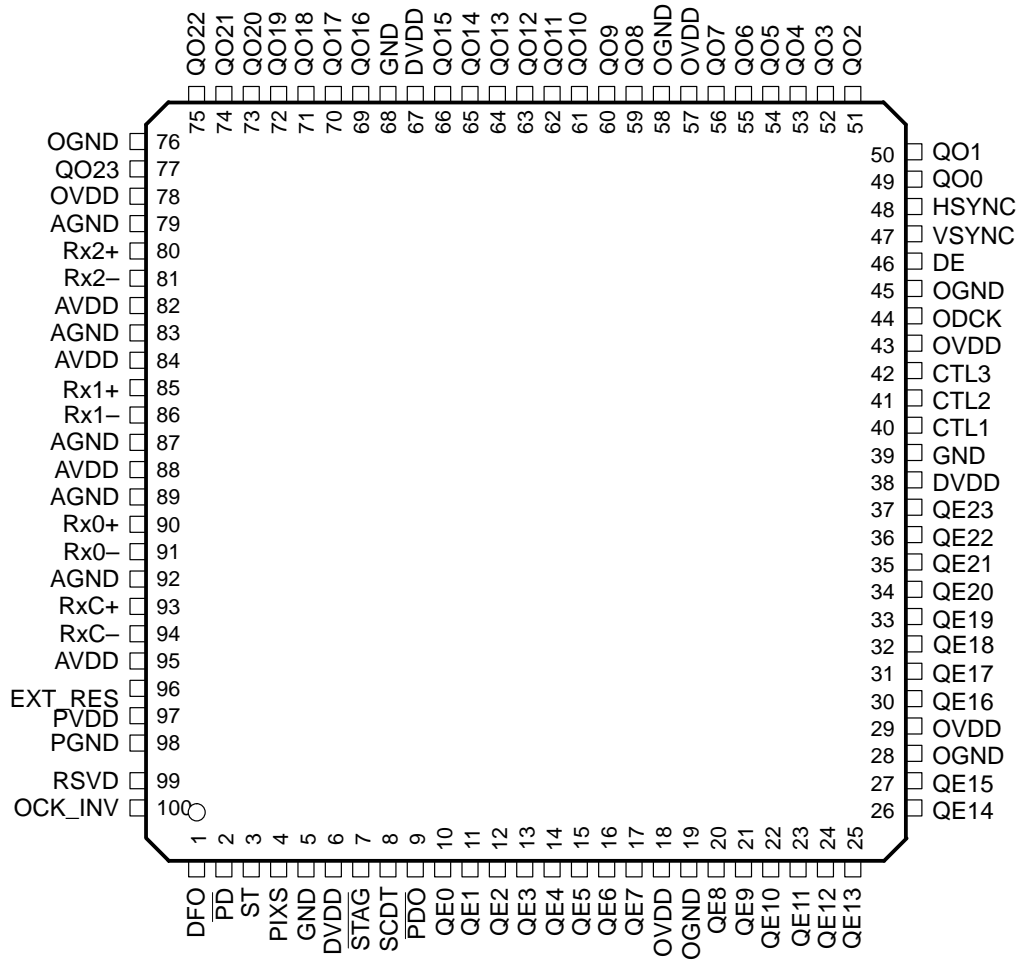

TFP201, TFP201A TI PanelBus™ DIGITAL RECEIVER

SLDS116A - MARCH 2000 – REVISED JUNE 2000

functional block diagram

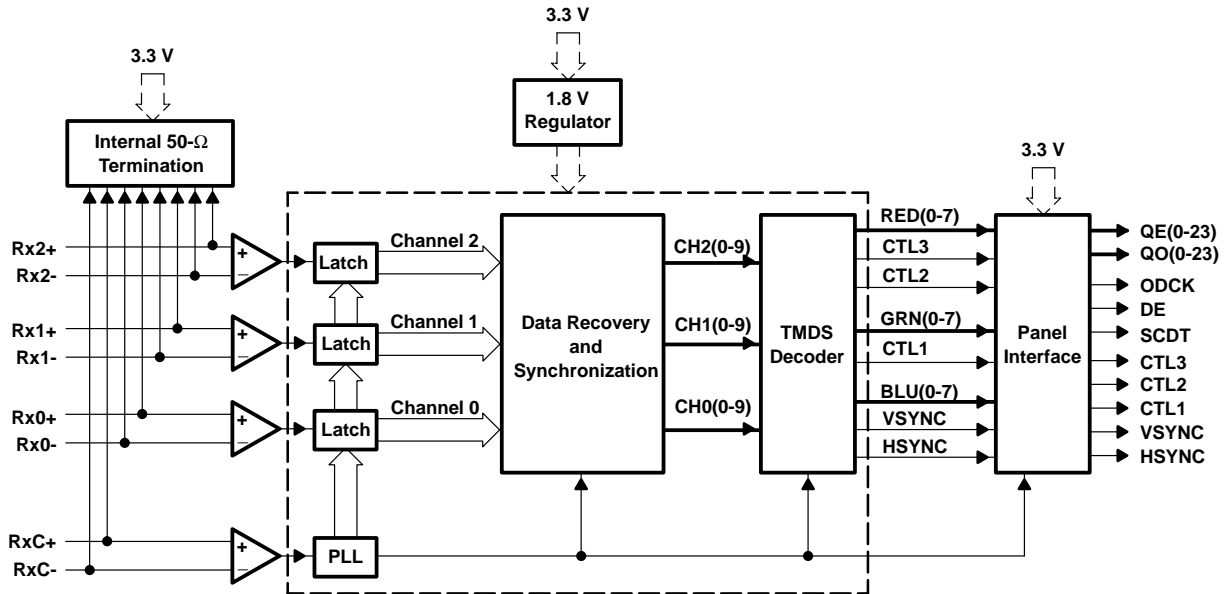

Terminal Functions

| TERMINAL NAME | NO. | I/O | DESCRIPTION |
|------------------|----------------|-----------------|---|
| AGND | 79,83,87,89,92 | GND | Analog Ground – Ground reference and current return for analog circuitry. |
| AV _{DD} | 82,84,88,95 | V _{DD} | Analog V _{DD} – Power supply for analog circuitry. Nominally 3.3 V |
| CTL[3:1] | 42,41,40 | DO | General-purpose control signals – Used for user defined control. CTL1 is not powered-down via P _{DO} . |
| DE | 46 | DO | Output data enable – Used to indicate time of active video display versus non-active display or blank time. During blank, only HSYNC, VSYNC, and CTL1-3 are transmitted. During times of active display, or non-blank, only pixel data, QE[23:0] and QO[23:0], is transmitted. High : Active display time Low: Blank time |
| DFO | 1 | DI | Output clock data format – Controls the output clock (ODCK) format for either TFT or DSTN panel support. For TFT support ODCK clock runs continuously. For DSTN support ODCK only clocks when DE is high, otherwise ODCK is held low when DE is low. High : DSTN support/ODCK held low when DE = low Low: TFT support/ODCK runs continuously. |
| DGND | 5,39,68 | GND | Digital ground – Ground reference and current return for digital core |
| DV _{DD} | 6,38,67 | V _{DD} | Digital V _{DD} – Power supply for digital core. Nominally 3.3 V |
| EXT_RES | 96 | AI | Internal impedance matching – The TFP201/201A is internally optimized for impedance matching at 50 Ω. An external resistor tied to this pin will have no effect on device performance. |
| HSYNC | 48 | DO | Horizontal sync output |
| RSVD | 99 | DI | Reserved. Must be tied high for normal operation. |
| OV _{DD} | 18,29,43,57,78 | V _{DD} | Output driver V _{DD} – Power supply for output drivers. Nominally 3.3 V |
| ODCK | 44 | DO | Output data clock - Pixel clock. All pixel outputs QE[23:0] and QO[23:0] (if in 2-pixel/clock mode) along with DE, HSYNC, VSYNC and CTL[3:1] are synchronized to this clock. |

TFP201, TFP201A

TI PanelBus™ DIGITAL RECEIVER

SLDS116A - MARCH 2000 – REVISED JUNE 2000

Terminal Functions (continued)

| TERMINAL NAME | NO. | I/O | DESCRIPTION |
|-------------------------|----------------|-----|--|
| OGND | 19,28,45,58,76 | GND | Output driver ground – Ground reference and current return for digital output drivers |
| OCK_INV | 100 | DI | ODCK Polarity – Selects ODCK edge on which pixel data (QE[23:0] and QO[23:0]) and control signals (HSYNC, VSYNC, DE, CTL1-3) are latched Normal Mode: High : Latches output data on rising ODCK edge Low : Latches output data on falling ODCK edge |
| PD | 2 | DI | Power down – An active low signal that controls the TFP201/201A power-down state. During power down all output buffers are switched to a high impedance state. All analog circuits are powered down and all inputs are disabled, except for $\overline{\text{PD}}$. If $\overline{\text{PD}}$ is left unconnected an internal pullup will default the TFP201/201A to normal operation. High : Normal operation Low: Power down |
| $\overline{\text{PDO}}$ | 9 | DI | Output drive power down – An active low signal that controls the power-down state of the output drivers. During output drive power down, the output drivers (except SCDT and CTL1) are driven to a high impedance state. When $\overline{\text{PDO}}$ is left unconnected, an internal pullup defaults the TFP201/201A to normal operation. High : Normal operation/output drivers on Low: Output drive power down. |
| PGND | 98 | GND | PLL GND – Ground reference and current return for internal PLL |
| PIXS | 4 | DI | Pixel select – Selects between one or two pixels per clock output modes. During the 2-pixel/clock mode, both even pixels, QE[23:0], and odd pixels, QO[23:0], are output in tandem on a given clock cycle. During 1-pixel/clock, even and odd pixels are output sequentially, one at a time, with the even pixel first, on the even pixel bus, QE[23:0]. (The first pixel per line is pixel-0, the even pixel. The second pixel per line is pixel-1, the odd pixel.) High : 2-pixel/clock Low: 1-pixel/clock |
| QE[0:7] | 10-17 | DO | Even blue pixel output – Output for even and odd blue pixels when in 1-pixel/clock mode. Output for even only blue pixel when in 2-pixel per clock mode. Output data is synchronized to the output data clock, ODCK. LSB: QE0/pin 10 MSB: QE7/pin 17 |
| QE[8:15] | 20-27 | DO | Even green pixel output – Output for even and odd green pixels when in 1-pixel/clock mode. Output for even only green pixel when in 2-pixel/clock mode. Output data is synchronized to the output data clock, ODCK. LSB: QE8/pin 20 MSB: QE15/pin 27 |
| QE[16:23] | 30-37 | DO | Even red pixel output – Output for even and odd red pixels when in 1-pixel/clock mode. Output for even only red pixel when in 2-pixel/clock mode. Output data is synchronized to the output data clock, ODCK. LSB: QE16/pin 30 MSB: QE23/pin 37 |
| QO[0:7] | 49-56 | DO | Odd blue pixel output – Output for odd only blue pixel when in 2-pixel/clock mode. Not used, and held low, when in 1-pixel/clock mode. Output data is synchronized to the output data clock, ODCK. LSB: QO0/pin 49 MSB: QO7/pin 56 |
| QO[8:15] | 59-66 | DO | Odd green pixel output – Output for odd only green pixel when in 2-pixel/clock mode. Not used, and held low, when in 1-pixel/clock mode. Output data is synchronized to the output data clock, ODCK. LSB: QO8/pin 59 MSB: QO15/pin 66 |
| QO[16:23] | 69-75,77 | DO | Odd red pixel output – Output for odd only red pixel when in 2-pixel/clock mode. Not used, and held low, when in 1-pixel/clock mode. Output data is synchronized to the output data clock, ODCK. LSB: QO16/pin 69 MSB: QO23/pin 77 |

Terminal Functions (continued)

| TERMINAL | | I/O | DESCRIPTION |
|----------|-----|-----|--|
| NAME | NO. | | |
| RxC+ | 93 | AI | Clock positive receiver input – Positive side of reference clock. TMDS low voltage signal differential input pair. |
| RxC- | 94 | AI | Clock negative receiver input – Negative side of reference clock. TMDS low voltage signal differential input pair. |
| Rx0+ | 90 | AI | Channel-0 positive receiver input – Positive side of channel-0. TMDS low voltage signal differential input pair. Channel-0 receives blue pixel data in active display and HSYNC, VSYNC control signals in blank. |
| Rx0- | 91 | AI | Channel-0 negative receiver input – Negative side of channel-0. TMDS low voltage signal differential input pair. |
| Rx1+ | 85 | AI | Channel-1 positive receiver input – Positive side of channel-1 TMDS low voltage signal differential input pair. Channel-1 receives green pixel data in active display and CTL1 control signals in blank. |
| Rx1- | 86 | AI | Channel-1 negative receiver input – Negative side of channel-1 TMDS low voltage signal differential input pair. |
| Rx2+ | 80 | AI | Channel-2 positive receiver input – Positive side of channel-2 TMDS low voltage signal differential input pair. Channel-2 receives red pixel data in active display and CTL2, CTL3 control signals in blank. |
| Rx2- | 81 | AI | Channel-2 negative receiver input – Negative side of channel-2 TMDS low voltage signal differential input pair. |
| SCDT | 8 | DO | Sync detect – Output to signal when the link is active or inactive. The link is considered to be active when DE is actively switching. The TFP201/201A monitors the state DE to determine link activity. SCDT can be tied externally to PDO to power down the output drivers when the link is inactive. High: Active link Low: Inactive link |
| ST | 3 | DI | Output drive strength select – Selects output drive strength for high or low current drive. (See dc specifications for I _{OH} and I _{OL} vs ST state.) High : High drive strength Low : Low drive strength |
| STAG | 7 | DI | Staggered pixel select – An active low signal used in the 2-pixel/clock pixel mode (PIXS = high). Time staggers the even and odd pixel outputs to reduce ground bounce. Normal operation outputs the odd and even pixels simultaneously. High : Normal simultaneous even/odd pixel output Low: Time staggered even/odd pixel output |
| VSYNC | 47 | DO | Vertical sync output |

absolute maximum ratings over operating free-air temperature (unless otherwise noted)†

| | |
|---|-------------------------|
| Supply voltage range, DV _{DD} , AV _{DD} , OV _{DD} , PV _{DD} | -0.3 V to 4 V |
| Input voltage range, logic/analog signals | -0.3 V to 4 V |
| Operating ambient temperature range | 0°C to 70°C |
| Storage temperature range | -65°C to 150°C |
| Case temperature for 10 seconds | 260°C |
| Lead temperature 1,6 mm (1/16 inch) from case for 10 seconds | 260°C |
| Package power dissipation/PowerPAD™: Soldered (see Note 1) | 4.3 W |
| Not soldered (see Note 2) | 2.7 W |
| ESD Protection, all pins | 2.5 KV Human Body Model |
| JEDEC latchup (EIA/JESD78) | 100 mA |

† Stresses beyond those listed under “absolute maximum ratings” may cause permanent damage to the device. These are stress ratings only, and functional operation of the device at these or any other conditions beyond those indicated under “recommended operating conditions” is not implied. Exposure to absolute-maximum-rated conditions for extended periods may affect device reliability.

- NOTES: 1. Specified with PowerPAD bond pad on the backside of the package soldered to a 2 oz. Cu plate PCB thermal plane. Specified at maximum allowed operating temperature, 70°C.
2. PowerPAD™ bond pad on the backside of the package is not soldered to a thermal plane. Specified at maximum allowed operating temperature, 70°C.

TFP201, TFP201A

TI PanelBus™ DIGITAL RECEIVER

SLDS116A - MARCH 2000 – REVISED JUNE 2000

recommended operating conditions

| | MIN | TYP | MAX | UNIT |
|--|-----|-----|-----|------|
| Supply voltage, V _{DD} (DV _{DD} , AV _{DD} , PV _{DD} , OV _{DD}) | 3 | 3.3 | 3.6 | V |
| Pixel time, t _{pix} † | 8.9 | | 40 | ns |
| Single ended analog input termination resistance, R _t | 45 | 50 | 55 | Ω |
| Operating free-air temperature, T _A | 0 | 25 | 70 | °C |

† t_{pix} is the pixel time defined as the period of the RxC clock input. The period of the output clock, ODCK is equal to t_{pix} when in 1-pixel/clock mode and 2t_{pix} when in 2-pixel/clock mode.

electrical characteristics over recommended operating free-air temperature range (unless otherwise noted)

dc digital I/O specifications

| PARAMETER | TEST CONDITIONS | MIN | TYP | MAX | UNIT |
|---|---|-----|-----|------------------|------|
| V _{IH} High level digital input voltage‡ | | 2 | | DV _{DD} | V |
| V _{IL} Low level digital input voltage‡ | | 0 | | 0.8 | V |
| I _{OH} High level output drive current§ | ST = High, V _{OH} = 2.4 V | 5 | 10 | 14 | mA |
| | ST = Low, V _{OH} = 2.4 V | 3 | 6 | 9 | |
| I _{OL} Low level output drive current§ | ST = High, V _{OL} = 0.8 V | 10 | 13 | 19 | mA |
| | ST = Low, V _{OL} = 0.8 V | 5 | 7 | 11 | |
| I _{OZ} Hi-Z output leakage current | \overline{PD} = Low or \overline{PDO} = Low | -1 | | 1 | μA |

‡ Digital inputs are labeled DI in I/O column of Terminal Functions Table.

§ Digital outputs are labeled DO in I/O column of Terminal Functions Table.

dc specifications

| PARAMETER | TEST CONDITIONS | MIN | TYP | MAX | UNIT |
|--|------------------------------|-----------------------|-----|----------------------|------|
| V _{ID} Analog input differential voltage (see Note 3) | | 75 | | 1200 | mv |
| V _{IC} Analog input common mode voltage (see Note 3) | | AV _{DD} -300 | | AV _{DD} +37 | mv |
| V _{I(OC)} Open circuit analog input voltage | | AV _{DD} -10 | | AV _{DD} +10 | mv |
| I _{DD(2PIX)} Normal 2-pix/clock power supply current (see Note 4) | ODCK = 56 MHz 2-pix/clock | | | 350 | mA |
| I _{PD} Power down current (see Note 5) | \overline{PD} = Low | | | 10 | mA |
| I _{PDO} Output drive power down current (see Note 5) | \overline{PDO} = Low | | 35 | | mA |

NOTES: 3. Specified as dc characteristic with no overshoot or undershoot.

4. Alternating 2-pixel black/2-pixel white pattern. ST = high, STAG = high, QE[23:0] and QO[23:0] C_L = 10 pF.

5. Analog inputs are open circuit (transmitter is disconnected from TFP201/201A).

TFP201, TFP201A TI PanelBus™ DIGITAL RECEIVER

SLDS116A - MARCH 2000 – REVISED JUNE 2000

electrical characteristics over recommended operating free-air temperature range (unless otherwise noted) (continued)

ac specifications

| PARAMETER | | TEST CONDITIONS | MIN | TYP | MAX | UNIT |
|-----------------------|--|--|------------|------|------------|--------------------|
| V _{ID(2)} | Differential input sensitivity† | | 150 | | 1560 | mV _{p-p} |
| t _{ps} | Analog input intra-pair (+ to -) differential skew (see Note 6) | | | | 0.4 | t _{bit} ‡ |
| t _{ccs} | Analog Input inter-pair or channel-to-channel skew (see Note 6) | | | | 1 | t _{pix} § |
| t _{jit} | Worse case differential input clock jitter tolerance¶ | (see Note 6) | 50 | | | ps |
| t _{f1} | Fall time of data and control signals#, | ST = Low, C _L =5 pF ST = High, C _L =10 pF | | | 2.4 1.9 | ns |
| t _{r1} | Rise time of data and control signals#, | ST = Low, C _L =5 pF ST = High, C _L =10 pF | | | 2.4 1.9 | ns |
| t _{r2} | Rise time of ODCK clock# | ST = Low, C _L =5 pF ST = High, C _L =10 pF | | | 2.4 1.9 | ns |
| t _{f2} | Fall time of ODCK clock# | ST = Low, C _L =5 pF ST = High, C _L =10 pF | | | 2.4 1.9 | ns |
| t _{su1} | Setup time, data and control signal to falling edge of ODCK (ODCK_INV = low) | ST = Low, C _L =5 pF ST = High, C _L =10 pF | 2.3 | | | ns |
| t _{h1} | Hold time, data and control signal to falling edge of ODCK (ODCK_INV = low) | ST = Low, C _L =5 pF ST = High, C _L =10 pF | 2.3 | | | ns |
| t _{su2} | Setup time, data and control signal to rising edge of ODCK (ODCK_INV = high) | ST = Low, C _L =5 pF ST = High, C _L =10 pF | 2.3 | | | ns |
| t _{h2} | Hold time, data and control signal to rising edge of ODCK (ODCK_INV = high) | ST = Low, C _L =5 pF ST = High, C _L =10 pF | 1.8 | | | ns |
| f _{ODCK} | ODCK frequency | PIX = Low (1-PIX/CLK) PIX = High (2-PIX/CLK) | 25 12.5 | | 112 56 | MHz |
| | ODCK duty-cycle | | 40% | 50% | 60% | |
| t _{pd(PDL)} | Propagation delay time from \overline{PD} low to Hi-Z outputs | | | | 9 | ns |
| t _{pd(PDOL)} | Propagation delay time from \overline{PDO} low to Hi-Z outputs | | | | 9 | ns |
| t _{t(HSC)} | Transition time between DE transition to SCDT low* | | | 1e6 | | t _{pix} |
| t _{t(FSC)} | Transition time between DE transition to SCDT high* | | | 1600 | | t _{pix} |
| t _{d(st)} | Delay time, ODCK latching edge to QE[23:0] data output | STAG = Low Pixs = High | | 0.25 | | t _{pix} |

† Specified as ac parameter to include sensitivity to overshoot, undershoot and reflection.

‡ t_{bit} is 1/10 the pixel time, t_{pix}

§ t_{pix} is the pixel time defined as the period of the RxC input clock. The period of ODCK is equal to t_{pix} in 1-pixel/clock mode or 2t_{pix} when in 2-pixel/clock mode.

¶ Measured differentially at 50% crossing using ODCK output clock as trigger.

Rise and fall times measured as time between 20% and 80% of signal amplitude.

|| Data and control signals are : QE[23:0], QO[23:0], DE, HSYNC, VSYNC and CTL[3:1]

*Link active or inactive is determined by amount of time detected between DE transitions. SCDT indicates link activity.

NOTE 6: By characterization

TFP201, TFP201A
TI PanelBus™ DIGITAL RECEIVER

SLDS116A - MARCH 2000 – REVISED JUNE 2000

PARAMETER MEASUREMENT INFORMATION

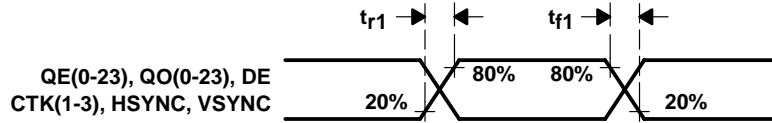

Figure 1. Rise and Fall Time of Data and Control Signals

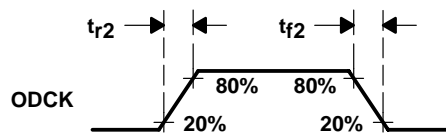

Figure 2. Rise and Fall Time of ODCK

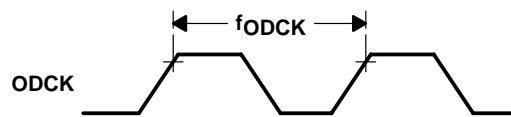

Figure 3. ODCK Frequency

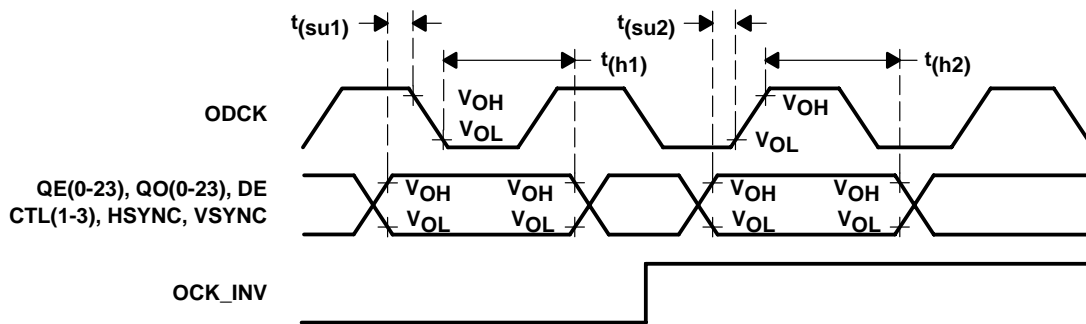

Figure 4. Data Setup and Hold Time to Rising and Falling Edge of ODCK

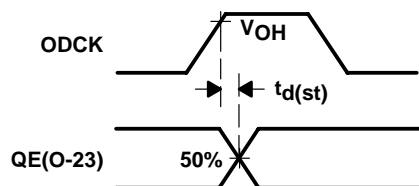

Figure 5. ODCK High to QE[23:0] Staggered Data Output

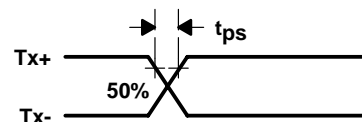

Figure 6. Analog Input Intra-Pair Differential Skew

PARAMETER MEASUREMENT INFORMATION

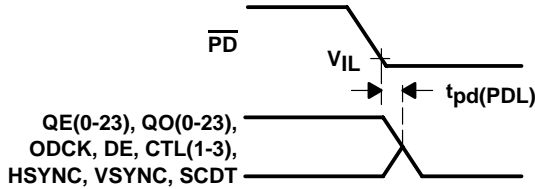

Figure 7. Delay From $\overline{\text{PD}}$ Low to Hi-Z Outputs

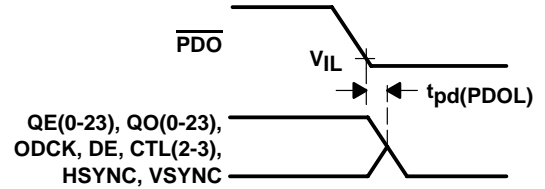

Figure 8. Delay From $\overline{\text{PDO}}$ Low to Hi-Z Outputs

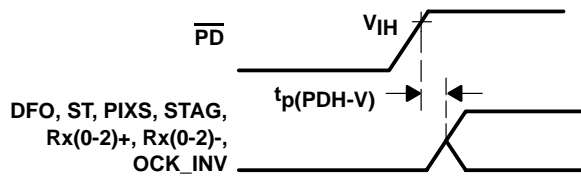

Figure 9. Delay From $\overline{\text{PD}}$ Low to High Before Inputs are Active

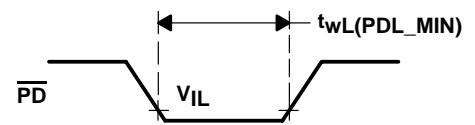

Figure 10. Minimum Time $\overline{\text{PD}}$ Low

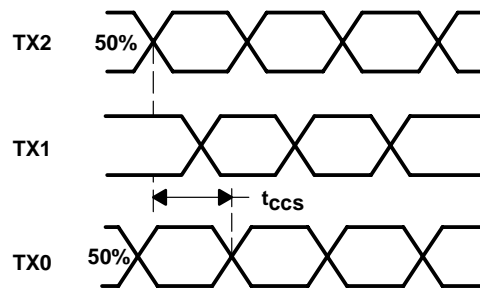

Figure 11. Analog Input Channel-to-Channel Skew

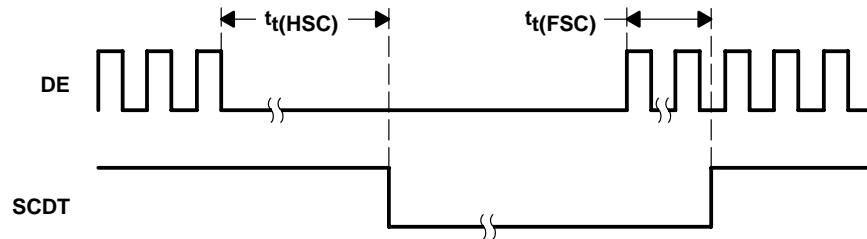

Figure 12. Time Between DE Transitions to SCDT Low and SCDT High

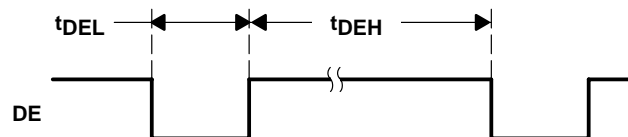

Figure 13. Minimum DE Low and Maximum DE High

TFP201, TFP201A

TI PanelBus™ DIGITAL RECEIVER

SLDS116A - MARCH 2000 – REVISED JUNE 2000

detailed description

fundamental operation

The TFP201/201A is a digital visual interface (DVI) compliant TMDS digital receiver that is used in digital flat panel display systems to receive and decode TMDS encoded RGB pixel data streams. In a digital display system a host, usually a PC or workstation, contains a TMDS compatible transmitter that receives 24 bit pixel data along with appropriate control signals and encodes them into a high-speed low-voltage differential serial bit stream fit for transmission over a twisted-pair cable to a display device. The display device, usually a flat-panel monitor, will require a TMDS compatible receiver like the TI TFP201/201A to decode the serial bit stream back to the same 24 bit pixel data and control signals that originated at the host. This decoded data can then be applied directly to the flat panel drive circuitry to produce an image on the display. Since the host and display can be separated by distances up to 5 meters or more, serial transmission of the pixel data is preferred. To support modern display resolutions up to SXGA a high bandwidth receiver with good jitter and skew tolerance is required.

TMDS pixel data and control signal encoding

TMDS stands for transition minimized differential signaling. Only one of two possible TMDS characters for a given pixel will be transmitted at a given time. The transmitter keeps a running count of the number of ones and zeros previously sent and transmits the character that will minimize the number of transitions and approximate a dc balance of the transmission line.

Three TMDS channels are used to receive RGB pixel data during active display time, DE = high. The same three channels also receive control signals, HSYNC, VSYNC, and user defined control signals CTL[3:1]. These control signals are received during inactive display or blanking-time. Blanking-time is when DE = low. The following table maps the received input data to appropriate TMDS input channel in a DVI compliant system.

| RECEIVED PIXEL DATA ACTIVE DISPLAY DE = HIGH | INPUT CHANNEL | OUTPUT PINS (VALID FOR DE = HIGH) |
|---|---------------------|--------------------------------------|
| Red[7:0] | Channel – 2 (Rx2 ±) | QE[23:16] QO[23:16] |
| Green[7:0] | Channel – 1 (Rx1 ±) | QE[15:8] QO[15:8] |
| Blue[7:0] | Channel – 0 (Rx0 ±) | QE[7:0] QO[7:0] |
| RECEIVED CONTROL DATA BLANKING DE = LOW | INPUT CHANNEL | OUTPUT PINS (VALID FOR DE = LOW) |
| CTL[3:2] | Channel – 2 (Rx2 ±) | CTL[3:2] |
| CTL[1: 0] (see Note 6) | Channel – 1 (Rx1 ±) | CTL1 |
| HSYNC, VSYNC | Channel – 0 (Rx0 ±) | HSYNC, VSYNC |

NOTE 7: Some TMDS transmitters transmit a CTL0 signal. The TFP201/201A decodes and transfers CTL[3:1] and ignores CTL0 characters. CTL0 is not available as a TFP201/201A output.

The TFP201/201A discriminates between valid pixel TMDS characters and control TMDS characters to determine the state of active display versus blanking, i.e., state of DE.

detailed description (continued)

TFP201/201A clocking and data synchronization

The TFP201/201A receives a clock reference from the TMDS transmitter that has a period equal to the pixel time, T_{pix} . The frequency of this clock is also referred to as the pixel rate. Since the TMDS encoded data on Rx[2:0] contains 10 bits per 8 bit pixel it follows that the Rx[2:0] serial bit rate is 10 times the pixel rate. For example, the required pixel rate to support an SXGA resolution with 60 Hz refresh rate is 112 MHz. The TMDS serial bit rate is 10x the pixel rate or 1.12 Gb/s. Due to the transmission of this high-speed digital bit stream, on three separate channels (or twisted-pair wires) of long distances (3-5 meters), phase synchronization between the data streams and the input reference clock is not guaranteed. In addition, skew between the three data channels is common. The TFP201/201A uses a 4x oversampling scheme of the input data streams to achieve reliable synchronization with up to $1 \cdot T_{pix}$ channel-to-channel skew tolerance. Accumulated jitter on the clock and data lines due to reflections and external noise sources is also typical of high speed serial data transmission, hence the TFP201/201A's design for high jitter tolerance.

The input clock to the TFP201/201A is conditioned by a phase-locked-loop (PLL) to remove high frequency jitter from the clock. The PLL provides four 10x clock outputs of different phase to locate and sync the TMDS data streams (4x oversampling). During active display the pixel data is encoded to be transition minimized, whereas in blank, the control data is encoded to be transition maximized. A DVI compliant transmitter is required to transmit in blank for a minimum period of time, $128 \cdot T_{pix}$, to ensure sufficient time for data synchronization when the receiver sees a transition maximized code. Synchronization during blank, when the data is transition maximized, ensures reliable data bit boundary detection. Phase synchronization to the data streams is unique for each of the three input channels and is maintained as long as the link remains active.

TFP201/201A TMDS input levels and input impedance matching

The TMDS inputs to the TFP201/201A receiver have a fixed single-ended termination to AV_{DD} . The TFP201/201A is internally optimized using a laser trim process to precisely fix the impedance at 50 Ω . The device will function normally with or without a resistor on the EXT_RES pin, so it remains drop-in compatible with current sockets. The fixed impedance eliminates the need for an external resistor while providing optimum impedance matching to standard 50- Ω DVI cables.

Figure 14 shows a conceptual schematic of a DVI transmitter and TFP201/201A receiver connection. A transmitter drives the twisted pair cable via a current source, usually achieved with an open drain type output driver. The internal resistor, which is matched to the cable impedance, at the TFP201/201A input provides a pullup to AV_{DD} . Naturally, when the transmitter is disconnected and the TFP201/201A DVI inputs are left unconnected, the TFP201/201A receiver inputs pullup to AV_{DD} . The single ended differential signal and full differential signal is shown in Figure 15. The TFP201/201A is designed to respond to differential signal swings ranging from 150 mV to 1.56 V with common mode voltages ranging from ($AV_{DD} - 300$ mV) to ($AV_{DD} - 37$ mV).

TFP201, TFP201A TI PanelBus™ DIGITAL RECEIVER

SLDS116A - MARCH 2000 – REVISED JUNE 2000

detailed description (continued)

TFP201/201A TMDS input levels and input impedance matching (continued)

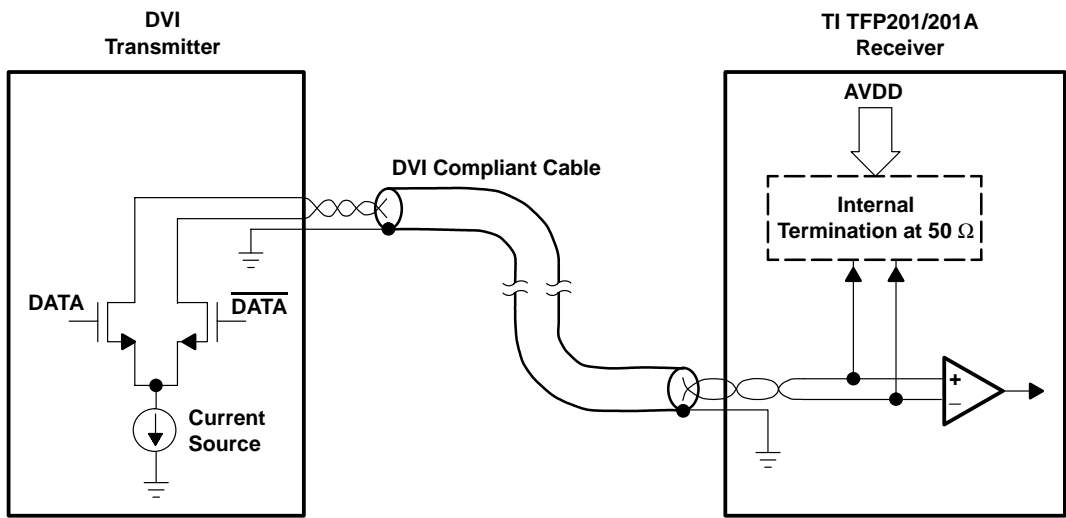

Figure 14. TMDS Differential Input and Transmitter Connection

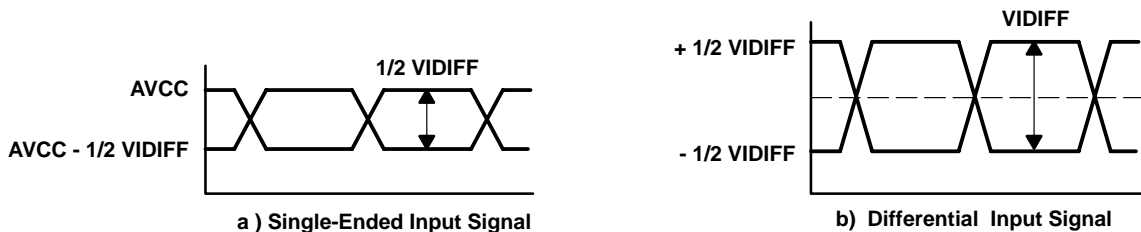

Figure 15. TMDS Inputs

TFP201A incorporates HSYNC jitter immunity

Several DVI transmitters available in the market introduce jitter on the transmitted HSYNC and VSYNC signals during the TMDS encryption process. The HSYNC signal can shift by one pixel position (one clock) from nominal in either direction, resulting in up to two cycles of HSYNC shift. This jitter carries through to the DVI receiver, and if the position of HSYNC shifts continuously, the receiver can lose track of the input timing and pixel noise will occur on the display. For this reason, a DVI compliant receiver with HSYNC jitter immunity should be used in all displays that could be connected to host PCs with transmitters that have this HSYNC jitter problem.

The TFP201A integrates HSYNC regeneration circuitry that provides a seamless interface to these noncompliant transmitters. The position of the data enable (DE) signal is always fixed in relation to data, irrespective of the location of HSYNC. The TFP201A receiver uses the DE and clock signals to recreate stable vertical and horizontal sync signals. The circuit filters the HSYNC output of the receiver, and HSYNC is shifted to the nearest eighth bit boundary, producing a stable output with respect to data, as shown in Figure 16. This will ensure accurate data synchronization at the input of the display timing controller.

TFP201A incorporates HSYNC jitter immunity (continued)

This HSYNC regeneration circuit is transparent to the monitor and need not be removed even if the transmitted HSYNC is stable. For example, the PanelBus line of DVI 1.0 compliant transmitters, such as the TFP6422 and TFP420, do not have the HSYNC jitter problem. The TFP201A will operate correctly with either compliant or noncompliant transmitters. In contrast, the TFP201 is ideal for customers who have control over the transmit portion of the design such as bundled system manufacturers and for internal monitor use (the DVI connection between monitor and panel modules).

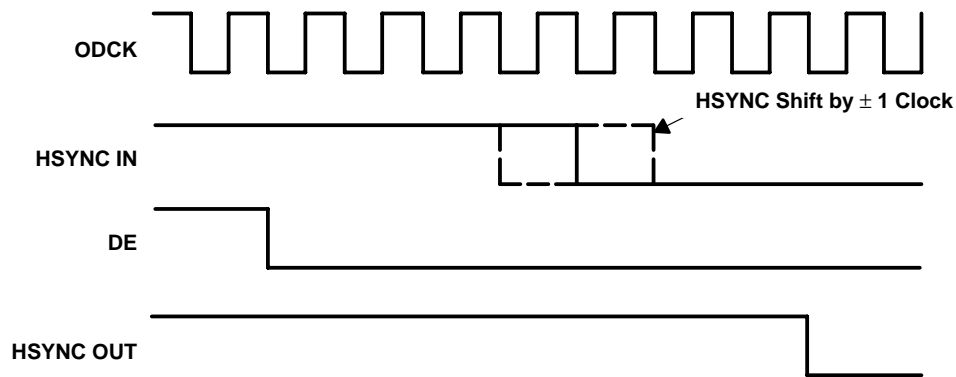

Figure 16. HSYNC Regeneration Timing Diagram

TFP201/201A modes of operation

The TFP201/201A provides systems design flexibility and value by providing the system designer with configurable options or modes of operation to support varying system architectures. The following table outlines the various panel modes that can be supported along with appropriate external control pin settings.

| PANEL | PIXEL RATE | ODCK LATCH EDGE | ODCK | DFO | PIXS | OCK_INV |
|--------------------|-------------|-----------------|-----------|-----|------|---------|
| TFT or 16-bit DSTN | 1 pix/clock | Falling | Free run | 0 | 0 | 0 |
| TFT or 16-bit DSTN | 1 pix/clock | Rising | Free run | 0 | 0 | 1 |
| TFT | 2 pix/clock | Falling | Free run | 0 | 1 | 0 |
| TFT | 2 pix/clock | Rising | Free run | 0 | 1 | 1 |
| 24-bit DSTN | 1 pix/clock | Falling | Gated low | 1 | 0 | 0 |
| NONE | 1 pix/clock | Rising | Gated low | 1 | 0 | 1 |
| 24-bit DSTN | 2 pix/clock | Falling | Gated low | 1 | 1 | 0 |
| 24-bit DSTN | 2 pix/clock | Rising | Gated low | 1 | 1 | 1 |

TFP201/201A output driver configurations

The TFP201/201A provides flexibility by offering various output driver features that can be used to optimize power consumption, ground-bounce and power-supply noise. The following sections outline the output driver features and their effects.

Output driver power down ($\overline{PDO} = \text{low}$), Pulling \overline{PDO} low will place all the output drivers, except CTL1 and SCDT, into a high-impedance state. The SCDT output which indicates link-disabled or link-inactive can be tied directly to the \overline{PDO} input to disable the output drivers when the link is inactive or when the cable is disconnected. An internal pullup on the \overline{PDO} pin will default the TFP201/201A to the normal nonpower down output drive mode if left unconnected.

TFP201, TFP201A

TI PanelBus™ DIGITAL RECEIVER

SLDS116A - MARCH 2000 – REVISED JUNE 2000

TFP201/201A output driver configurations (continued)

Drive Strength (ST = high for high drive strength, ST=low for low drive strength.) The TFP201/201A allows for selectable output drive strength on the data, control and ODCK outputs. See the dc specifications table for the values of I_{OH} and I_{OL} current drives for a given ST state. The high output strength offers approximately two times the drive as the low output drive strength.

Time Staggered Pixel Output. This option works only in conjunction with the 2-pixel/clock mode (PIXS = high). Setting \overline{STAG} = low will time stagger the even and odd pixel output so as to reduce the amount of instantaneous current surge from the power supply. Depending on the PCB layout and design this can help reduce the amount of system ground bounce and power supply noise. The time stagger is such that in 2-pixel/clock mode the even pixel is delayed from the latching edge of ODCK by 0.25 Tcip. (Tcip is the period of ODCK. The ODCK period is 2Tpix when in 2-pixel/clock mode.)

Depending on system constraints of output load, pixel rate, panel input architecture and board cost the TFP201/201A drive strength and staggered pixel options allow flexibility to reduce system power-supply noise, ground bounce and EMI.

Power Management. The TFP201/201A offers several system power management features.

The output driver power down (\overline{PDO} = low) is an intermediate mode which offers several uses. During this mode, all output drivers except SCDT and CTL1 are driven to a high impedance state while the rest of the device circuitry remains active

The TFP201/201A power down (\overline{PD} = low) is a complete power down in that it powers down the digital core, the analog circuitry, and output drivers. All output drivers are placed into a Hi-z state. All inputs are disabled except for the \overline{PD} input. The TFP201/201A will not respond to any digital or analog inputs until \overline{PD} is pulled high.

Both \overline{PDO} and \overline{PD} have internal pullups so if left unconnected they will default the TFP201/201A to normal operating modes.

Sync Detect. The TFP201/201A offers an output, SCDT to indicate link activity. The TFP201/201A monitors activity on DE to determine if the link is active. When 1 million (1e6) pixel clock periods pass without a transition on DE, the TFP201/201A considers the link inactive and SCDT is driven low. While SCDT is low, if two DE transitions are detected within 1600 pixel clock periods, the link will be considered active and SCDT is pulled high.

SCDT can be used to signal a system power management circuit to initiate a system power down when the link is considered inactive. The SCDT can also be tied directly to the TFP201/201A \overline{PDO} input to power down the output drivers when the link is inactive. It is not recommended to use the SCDT to drive the \overline{PD} input since, once in complete power-down, the analog inputs are ignored and the SCDT state will not change. An external system power management circuit to drive \overline{PD} is preferred.

TI PowerPAD™ 100-TQFP package

The TFP201/201A is packaged in TI's thermally enhanced PowerPAD™ 100TQFP packaging. The PowerPAD™ package is a 14 mm × 14 mm × 1 mm TQFP outline with 0.5mm lead-pitch. The PowerPAD™ package has a specially designed die mount pad that offers improved thermal capability over typical TQFP packages of the same outline. The TI 100-TQFP PowerPAD™ package offers a back-side solder plane that connects directly to the die mount pad for enhanced thermal conduction. Soldering the back side of the TFP201/201A to the application board is not required thermally as the device power dissipation is well within the package capability when not soldered.

Soldering the back side of the device to the PCB ground plane is recommended for electrical considerations. Since the die pad is electrically connected to the chip substrate and hence chip ground, connection of the PowerPAD back side to a PCB ground plane will help to improve EMI, ground bounce, and power supply noise performance.

TFP201, TFP201A
TI PanelBus™ DIGITAL RECEIVER

SLDS116A - MARCH 2000 – REVISED JUNE 2000

Table 1 outlines the thermal properties of the TI 100-TQFP PowerPAD™ package. The 100-TQFP non-PowerPAD™ package is included only for reference.

Table 1. TI 100-TQFP (14 × 14 × 1 mm)/0.5 mm Lead Pitch

| PARAMETER | WITHOUT PowerPAD™ | PowerPAD™ NOT CONNECTED TO PCB THERMAL PLANE | PowerPAD™ CONNECTED TO PCB THERMAL PLANE† |
|--------------------------------|----------------------|--|---|
| Theta-JA†,‡ | 45°C/W | 27.3°C/W | 17.3°C/W |
| Theta-JC†,‡ | 3.11°C/W | 0.12°C/W | 0.12°C/W |
| Maximum power dissipation†,‡,§ | 1.6 W | 2.7 W | 4.3 W |

† Specified with 2 oz. Cu PCB plating.

‡ Airflow is at 0 LFM (no airflow)

§ Measured at ambient temperature, T_A = 70°C.

THERMAL PAD MECHANICAL DATA

PZP (S-PQFP-G100)

PowerPAD™ PLASTIC QUAD FLATPACK

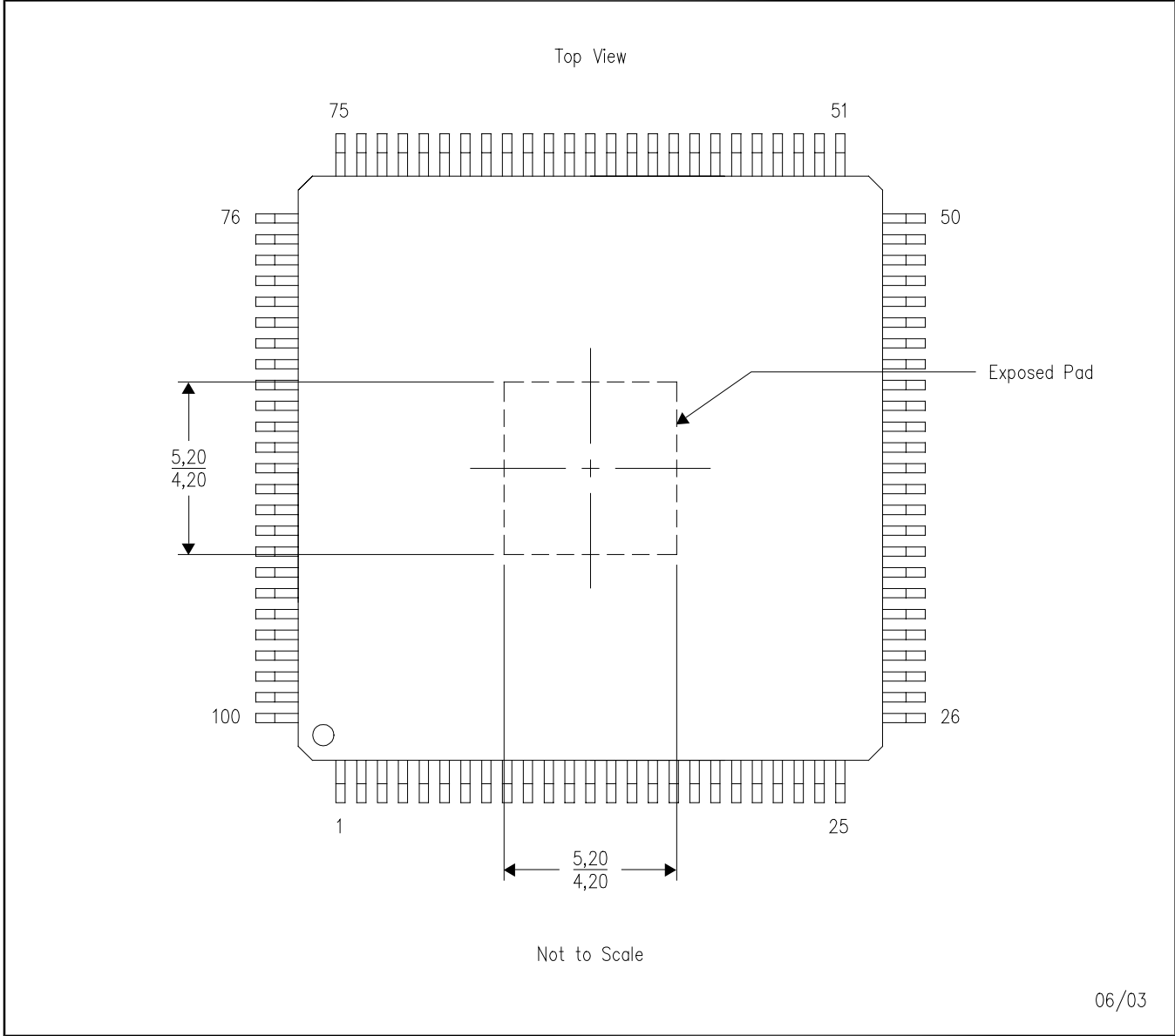

- NOTES:
- A. All linear dimensions are in millimeters.
 - B. This drawing is subject to change without notice.
 - C. For additional information on the PowerPAD™ package and how to take advantage of its heat dissipating abilities, refer to Technical Brief, **PowerPAD Thermally Enhanced Package**, Texas Instruments Literature No. SLMA002 and Application Brief, **PowerPAD Made Easy**, Texas Instruments Literature No. SLMA004. Both documents are available at www.ti.com.

TFP201, TFP201A
TI PanelBus™ DIGITAL RECEIVER

SLDS116A - MARCH 2000 – REVISED JUNE 2000

MECHANICAL DATA

PZP (S-PQFP-G100)

PowerPAD™ PLASTIC QUAD FLATPACK

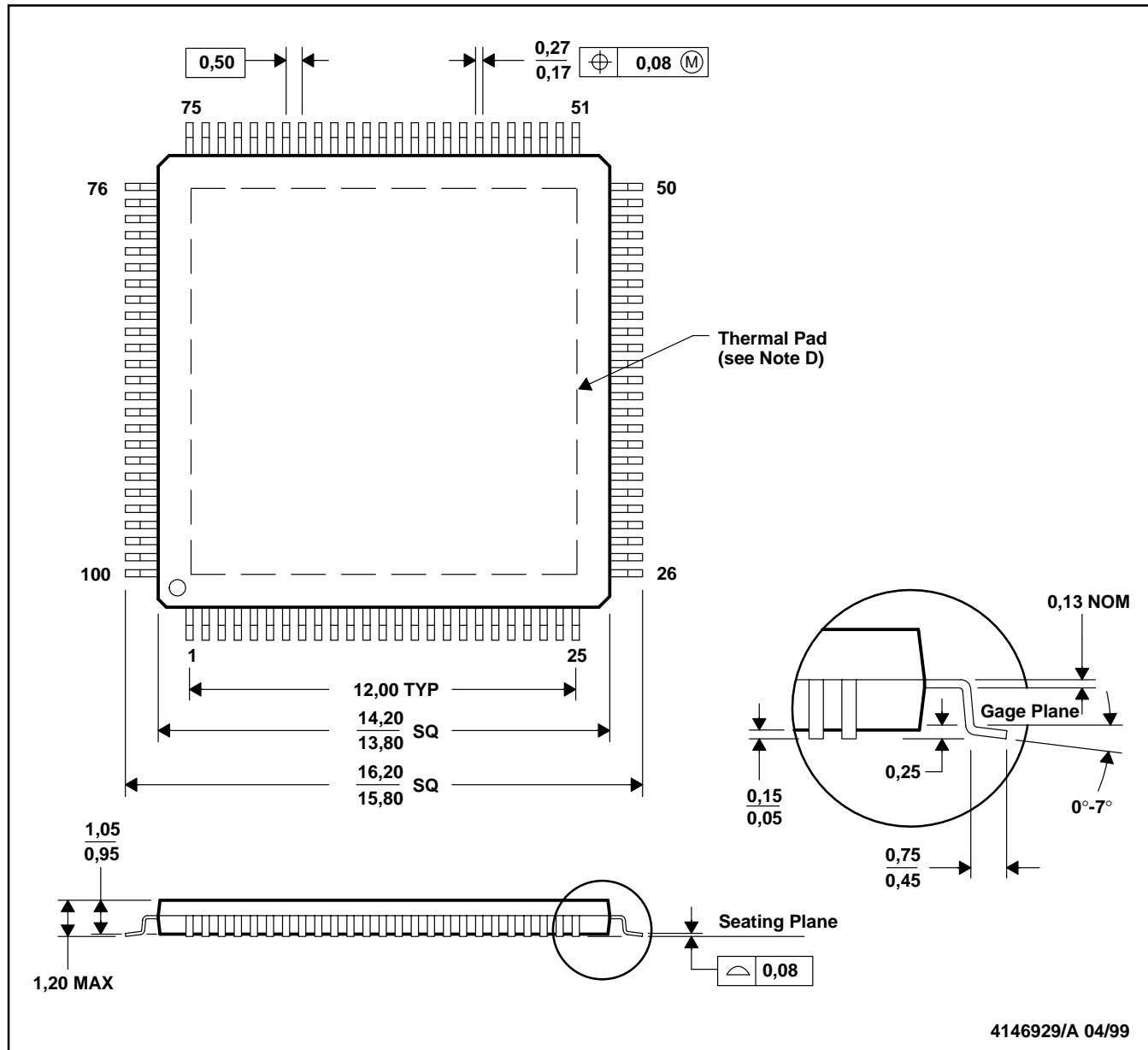

- NOTES: A. All linear dimensions are in millimeters.
 B. This drawing is subject to change without notice.
 C. Body dimensions do not include mold flash or protrusion.
 D. The package thermal performance may be enhanced by bonding the thermal pad to an external thermal plane. This pad is electrically and thermally connected to the backside of the die and possibly selected leads.
 E. Falls within JEDEC MS-026

PowerPAD is a trademark of Texas Instruments.

IMPORTANT NOTICE

Texas Instruments Incorporated and its subsidiaries (TI) reserve the right to make corrections, modifications, enhancements, improvements, and other changes to its products and services at any time and to discontinue any product or service without notice. Customers should obtain the latest relevant information before placing orders and should verify that such information is current and complete. All products are sold subject to TI's terms and conditions of sale supplied at the time of order acknowledgment.

TI warrants performance of its hardware products to the specifications applicable at the time of sale in accordance with TI's standard warranty. Testing and other quality control techniques are used to the extent TI deems necessary to support this warranty. Except where mandated by government requirements, testing of all parameters of each product is not necessarily performed.

TI assumes no liability for applications assistance or customer product design. Customers are responsible for their products and applications using TI components. To minimize the risks associated with customer products and applications, customers should provide adequate design and operating safeguards.

TI does not warrant or represent that any license, either express or implied, is granted under any TI patent right, copyright, mask work right, or other TI intellectual property right relating to any combination, machine, or process in which TI products or services are used. Information published by TI regarding third-party products or services does not constitute a license from TI to use such products or services or a warranty or endorsement thereof. Use of such information may require a license from a third party under the patents or other intellectual property of the third party, or a license from TI under the patents or other intellectual property of TI.

Reproduction of information in TI data books or data sheets is permissible only if reproduction is without alteration and is accompanied by all associated warranties, conditions, limitations, and notices. Reproduction of this information with alteration is an unfair and deceptive business practice. TI is not responsible or liable for such altered documentation.

Resale of TI products or services with statements different from or beyond the parameters stated by TI for that product or service voids all express and any implied warranties for the associated TI product or service and is an unfair and deceptive business practice. TI is not responsible or liable for any such statements.

Mailing Address:

Texas Instruments
Post Office Box 655303
Dallas, Texas 75265