

- Single-Chip RF Transceiver for 868-MHz and 915-MHz ISM Bands
- 850-MHz to 950-MHz Operation
- FM/FSK Operation for Transmit and Receive
- 24-Bit Direct Digital Synthesizer (DDS) With 11-Bit DAC
- On-Chip VCO and PLL
- On-Chip Reference Oscillator
- Minimal External Components Required
- Low Power Consumption
- Typical Output Power of 4.5 dBm
- Typical Output Frequency Resolution of 230 Hz
- Ultrafast Lock Times From DDS Implementation
- Two Fully-Programmable Operational Modes
- 2.2-V to 3.6-V Operation
- Fast Radio Strength Signal Indicator (RSSI)
- Flexible Serial Interface to TI MSP430 Microcontroller
- 48-Pin Low-Profile Plastic Quad Flat Package (PQFP)

PQFP PACKAGE
(TOP VIEW)

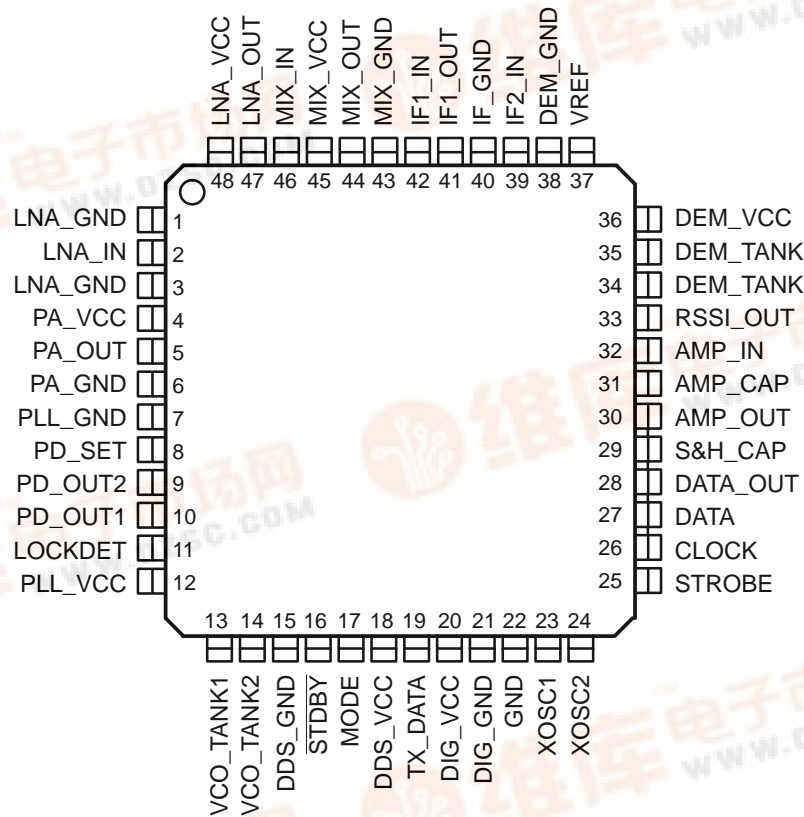

These devices have limited built-in ESD protection. The leads should be shorted together or the device placed in conductive foam during storage or handling to prevent electrostatic damage to the MOS gates.

Please be aware that an important notice concerning availability, standard warranty, and use in critical applications of Texas Instruments semiconductor products and disclaimers thereto appears at the end of this data sheet.

TRF6900A

SINGLE-CHIP RF TRANSCEIVER

SLAS258D – SEPTEMBER 2000 – REVISED SEPTEMBER 2001

description

The TRF6900A single-chip solution is an integrated circuit intended for use as a low cost FSK transceiver to establish a frequency-agile, half-duplex, bidirectional RF link. The device is available in a 48-lead TQFP package and is designed to provide a fully-functional multichannel FM transceiver. The chip is intended for linear (FM) or digital (FSK) modulated applications in the new 868-MHz European band and the North American 915-MHz ISM band. The single chip transceiver operates down to 2.2 V and is expressly designed for low power consumption. The synthesizer has a typical channel spacing of approximately 230 Hz to allow narrow-band as well as wide-band application. Due to the narrow channel spacing of the direct digital synthesizer (DDS), the DDS can be used to adjust the TX/RX frequency and allows the use of inexpensive reference crystals.

Two fully-programmable operation modes, Mode0 and Mode1, allow extremely fast switching between two preprogrammed settings (e.g., receive(RX)/transmit(TX); TX_frequency_0/TX_frequency_1; RX_frequency_0/RX_frequency_1;...) without reprogramming the device. Each functional block of the transceiver can be specifically enabled or disabled via the serial interface.

ISM band standards

Europe has assigned a new unlicensed frequency band of 868 MHz to 870 MHz. This new band is specifically defined for short range devices with duty cycles from 0.1% to 100% in several sub-bands. The existing 433-MHz band for short-range devices in Europe has the great disadvantage of very high usage. The new European frequency band, due to the duty cycle assignment, allows a reliable RF link and makes many new applications possible.

The North American unlicensed ISM (industrial, scientific, and medical) band covers 902 MHz to 928 MHz (center frequency of 915 MHz), and is suitable for short range RF links.

transmitter

The transmitter consists of an integrated VCO, a complete fully-programmable direct digital synthesizer, and a power amplifier. The internal VCO can be used with an external tank circuit or an external VCO. The divider, prescaler, and reference oscillator require only the addition of an external crystal and a loop filter to provide a complete DDS with a typical frequency resolution of 230 Hz.

The 8-bit FSK frequency deviation register determines the frequency deviation in FSK mode. The modulation itself is done in the direct digital synthesizer, hence no additional external components are necessary.

Since the typical RF output power is approximately 4.5 dBm, no additional external RF power amplifier is necessary in most applications.

receiver

The integrated receiver is intended to be used as a single-conversion FSK receiver. It consists of a low-noise amplifier, mixer, IF amplifier, limiter, FM/FSK demodulator with an external LC tank circuit, and a data slicer. The receive strength signal indicator (RSSI) can be used for fast carrier sense detection or as an on/off keying, or amplitude shift keying, (OOK/ASK) demodulator. In the *learning mode*, during a learning sequence (0,1,0,1,0,...), the initial tolerances of the LC demodulator tank circuit are compensated and an external capacitor is charged to a dc voltage that is proportional to the average demodulation dc level. This level is the zero reference for the data slicer to generate the logical levels of the data sequence that follow the learning sequence. Using the internal data switch, the demodulated OOK and FSK signals are available at the same DATA_OUT terminal.

baseband interface

The TRF6900A can easily be interfaced to a baseband processor such as the Texas Instruments MSP430 ultralow-power microcontroller (see Figure 1). The TRF6900A serial control registers are programmed by the MSP430 and the MSP430 performs baseband operations in software.

TRF6900A SINGLE-CHIP RF TRANSCEIVER

SLAS258D – SEPTEMBER 2000 – REVISED SEPTEMBER 2001

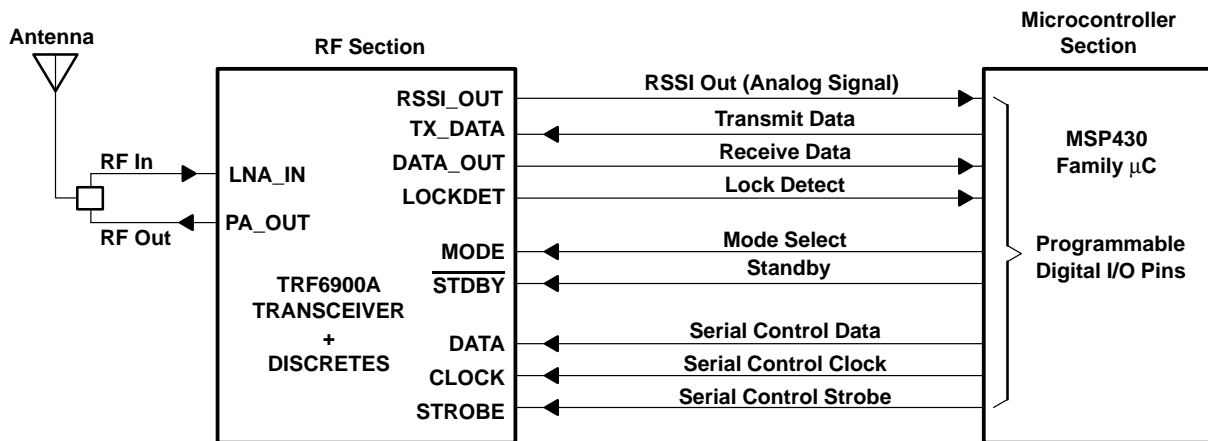
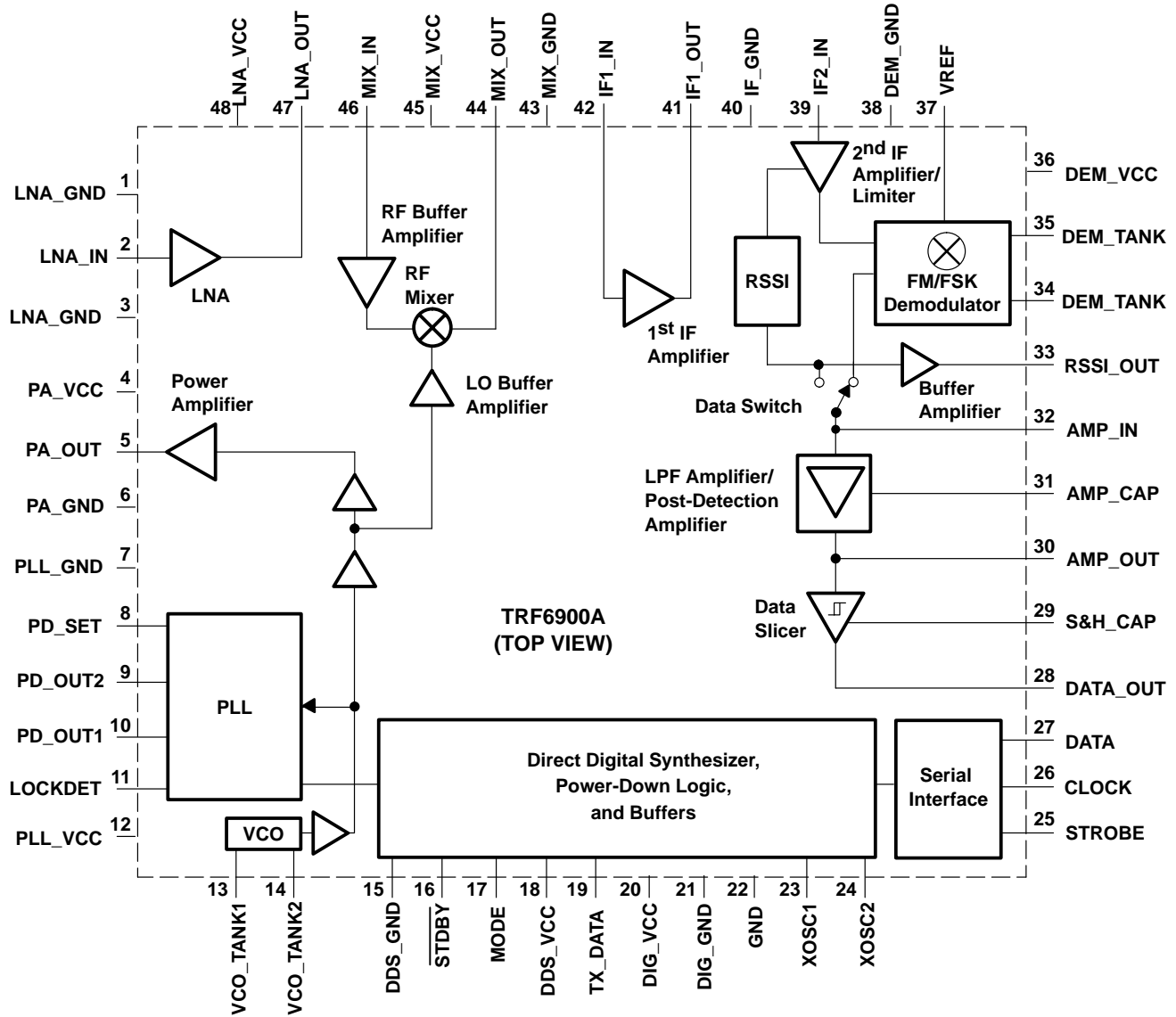

Figure 1. System Block Diagram for Interfacing to the MSP430 Microcontroller

TRF6900A SINGLE-CHIP RF TRANSCEIVER

SLAS258D – SEPTEMBER 2000 – REVISED SEPTEMBER 2001

functional block diagram



Terminal Functions

TERMINAL NAME	NO.	I/O	DESCRIPTION
AMP_CAP	31	I/O	Connection for LPF amplifier/post-detection amplifier capacitor/resistor used to reduce the internal low-pass filter frequency and to adjust the post-detection gain.
AMP_IN	32	I	Analog post-detection amplifier input
AMP_OUT	30	O	Analog post-detection amplifier output
CLOCK	26	I	Serial interface clock signal
DATA	27	I	Serial interface data signal
DATA_OUT	28	O	Digital output of the data slicer, active high
DDS_GND	15		Direct digital synthesizer ground

TRF6900A SINGLE-CHIP RF TRANSCEIVER

SLAS258D – SEPTEMBER 2000 – REVISED SEPTEMBER 2001

Terminal Functions (Continued)

TERMINAL NAME	NO.	I/O	DESCRIPTION
DDS_VCC	18		Direct digital synthesizer supply voltage
DEM_GND	38		Quadrature demodulator ground
DEM_TANK	34, 35	I/O	Quadrature demodulator tank connection
DEM_VCC	36		Quadrature demodulator supply voltage
DIG_GND	21		Digital ground
DIG_VCC	20		Digital supply voltage
IF_GND	40		Intermediate frequency (IF) section ground
IF1_IN	42	I	Single-ended input for the 1 st intermediate frequency (IF) amplifier
IF1_OUT	41	O	Single-ended output for the 1 st intermediate frequency (IF) amplifier
IF2_IN	39	I	Single-ended input for the 2 nd IF amplifier/limiter
LNA_GND	1, 3		Low-noise amplifier ground
LNA_IN	2	I	Low-noise amplifier input
LNA_OUT	47	O	Low-noise amplifier output, open collector
LNA_VCC	48		Low-noise amplifier supply voltage
LOCKDET	11	O	PLL lock detect output, active high. PLL locked when LOCKDET = 1.
MIX_GND	43		Mixer ground
MIX_IN	46	I	Single-ended RF mixer input
MIX_OUT	44	O	Single-ended RF mixer output
MIX_VCC	45		Mixer supply voltage
MODE	17	I	Mode select input. The functionality of the device in Mode0 or Mode1 can be programmed via the A-, B-, C-, and D-word of the serial control interface.
GND	22		Ground
PA_GND	6		Power amplifier ground
PA_OUT	5	O	Power amplifier output, open collector
PA_VCC	4		Power amplifier supply voltage
PD_OUT1	10	O	Charge pump output – PLL in locked condition
PD_OUT2	9	O	Charge pump output – PLL in unlocked condition
PD_SET	8		Charge pump current setting terminal. An external resistor (R _{PD}) is connected to this terminal to set the nominal charge pump current.
PLL_GND	7		PLL ground
PLL_VCC	12		PLL supply voltage
RSSI_OUT	33	O	Receive strength signal indicator, analog output
S&H_CAP	29	I/O	Connection for sample and hold capacitor for the data slicer. This capacitor determines the integration time constant of the integrator while in the learning mode.
$\overline{\text{STDBY}}$	16	I	Standby control for the TRF6900A, active low. While $\overline{\text{STDBY}} = 0$, the contents of the control registers are still valid and can be programmed via the serial control interface.
STROBE	25	I	Serial interface strobe signal
TX_DATA	19	I	Digital modulation buffered input for FSK/FM modulation of the carrier, active high
VCO_TANK1	13	I	VCO tank circuit connection. Should be left open if an external VCO is used.
VCO_TANK2	14	I	VCO tank circuit connection. May also be used to input an external VCO signal.
VREF	37	I	Reference voltage for the quadrature demodulator
XOSC1	23	O	Reference crystal oscillator connection
XOSC2	24	I	Reference crystal oscillator connection. May be used as a single-ended clock input if an external crystal is not used.

TRF6900A SINGLE-CHIP RF TRANSCEIVER

SLAS258D – SEPTEMBER 2000 – REVISED SEPTEMBER 2001

absolute maximum ratings over operating free-air temperature (unless otherwise noted)†

Supply voltage range, PA_VCC, PLL_VCC, DDS_VCC, DIG_VCC, DEM_VCC, MIX_VCC, LNA_VCC (see Note 1)	-0.6 to 4.5 Vdc
Input voltage, V _I (logic signals)	-0.6 to 4.5 Vdc
Storage temperature range, T _{stg}	-65°C to 150°C

† Stresses beyond those listed under “absolute maximum ratings” may cause permanent damage to the device. These are stress ratings only, and functional operation of the device at these or any other conditions beyond those indicated under “recommended operating conditions” is not implied. Exposure to absolute-maximum-rated conditions for extended periods may affect device reliability.

NOTE 1: All GND and VCC terminals must be connected to either ground or supply, respectively, even if the function block is not used.

recommended operating conditions

	MIN	TYP	MAX	UNIT
Supply voltage, PA_VCC, PLL_VCC, DIG_VCC, DDS_VCC, DEM_VCC, MIX_VCC, LNA_VCC	2.2		3.6	V
Operating temperature	-20		60	°C
High-level input voltage, V _{IH} (DATA, CLOCK, STROBE, TX_DATA, MODE, STDBY)	V _{CC} -0.5			V
Low-level input voltage, V _{IL} (DATA, CLOCK, STROBE, TX_DATA, MODE, STDBY)			0.5	V
High-level output voltage, V _{OH} (LOCKDET, DATA_OUT); I _{OH} = 0.5 mA	V _{CC} -0.5			V
Low-level output voltage, V _{OL} (LOCKDET, DATA_OUT); I _{OL} = 0.5 mA			0.5	V

electrical characteristics over full range of operating conditions, (typical values are at PA_VCC, PLL_VCC, DDS_VCC, DIG_VCC, DEM_VCC, MIX_VCC, LNA_VCC = 3 V, T_A = 25°C) (unless otherwise noted)

supply current consumption in each mode

MODE		ACTIVE STAGES	MIN	TYP	MAX	UNIT
Power down (standby mode)		None		0.5	5	μA
RX – FSK (narrow-band) or Carrier sense		DDS, PLL, VCO, LNA (normal mode), mixer, first IF amplifier, limiter, (demodulator, LPF amplifier, data slicer or RSSI)		26	34	mA
TX	PA STATE	DDS, PLL, VCO, PA				mA
	0-dB attenuation			37	50	
	10-dB attenuation			26	33	
	20-dB attenuation			21	25	
	PA disabled			9.5	12	

TRF6900A SINGLE-CHIP RF TRANSCEIVER

SLAS258D – SEPTEMBER 2000 – REVISED SEPTEMBER 2001

electrical characteristics over full range of operating conditions, (typical values are at PA_VCC, PLL_VCC, DDS_VCC, DIG_VCC, DEM_VCC, MIX_VCC, LNA_VCC = 3 V, T_A = 25°C) (unless otherwise noted) (continued)

LNA/RF mixer

PARAMETER	TEST CONDITIONS	MIN	TYP	MAX	UNIT
RF frequency range		850		950	MHz
LNA gain	LNA in normal mode	9	13		dB
	LNA in low-gain mode		2		dB
LNA noise figure	LNA in normal mode		3.3	5.5	dB
LNA input 1-dB compression	LNA in normal mode	-20	-15		dBm
	LNA in low-gain mode	-18	-13		dBm
LNA input IP3	LNA in normal mode	-12	-5		dBm
	LNA in low-gain mode	-6	1		dBm
LNA input impedance		See Figure 3			Ω
LNA output impedance		See Figure 4			Ω
LO frequency range		850		950	MHz
IF frequency range		10		21.4	MHz
Mixer conversion gain		3	7.5		dB
Mixer SSB noise figure	IF frequency = 10.7 MHz		17.5		dB
Mixer input impedance		See Figure 5			Ω
Mixer input IP3		-7	1		dBm
Mixer input 1-dB compression			-9		dBm
LO level at mixer input				-35	dBm
Mixer output impedance	IF frequency = 10.7 MHz, See Figure 6		330		Ω

VCO

PARAMETER	TEST CONDITIONS	MIN	TYP	MAX	UNIT
Frequency range		850		950	MHz
Tuning range			30		MHz
Phase noise	50-kHz offset		-86		dBc/Hz
Tuning voltage		0.5	V _{CC} -0.4		V

TRF6900A

SINGLE-CHIP RF TRANSCEIVER

SLAS258D – SEPTEMBER 2000 – REVISED SEPTEMBER 2001

electrical characteristics over full range of operating conditions, (typical values are at PA_VCC, PLL_VCC, DDS_VCC, DIG_VCC, DEM_VCC, MIX_VCC, LNA_VCC = 3 V, T_A = 25°C) (unless otherwise noted) (continued)

1st IF amplifier

PARAMETER	TEST CONDITIONS	MIN	TYP	MAX	UNIT
IF amplifier frequency range		10		21.4	MHz
IF amplifier gain		5.5	7		dB
IF amplifier noise figure			11	13	dB
IF amplifier input 1-dB compression		-12	-3		dBm
IF amplifier input IP3		-3.5	4		dBm
IF amplifier input impedance	IF frequency = 10.7 MHz, See Figure 8		330		Ω
IF amplifier output impedance	IF frequency = 10.7 MHz, See Figure 9		330		Ω

2nd IF amplifier/limiter

PARAMETER	TEST CONDITIONS	MIN	TYP	MAX	UNIT
IF amplifier/limiter frequency range		10		21.4	MHz
IF amplifier/limiter gain			80		dB
IF amplifier/limiter noise figure			9		dB
IF amplifier/limiter input impedance	IF frequency = 10.7 MHz, See Figure 10		330		Ω

RSSI

PARAMETER	TEST CONDITIONS	MIN	TYP	MAX	UNIT
RSSI range at limiter input		-80		-10	dBm
RSSI output voltage range		0.44		2.6	V
Nominal slope			19		mV/dB
Response time step from power off to -20 dBm at limiter input			1	5	μs

low-pass filter amplifier [2nd order]

PARAMETER	TEST CONDITIONS	MIN	TYP	MAX	UNIT
Internal low-pass filter frequency			0.75		MHz

demodulator

PARAMETER	TEST CONDITIONS	MIN	TYP	MAX	UNIT
Demodulation output bandwidth	IF frequency = 10.7 MHz		0.3		MHz
Acquisition range	IF frequency = 10.7 MHz		300		kHz
Slew rate†			2		V/μs

† Dependent upon external LC tank circuit.

data slicer

PARAMETER	TEST CONDITIONS	MIN	TYP	MAX	UNIT
Output current	R _(load) = 3.3 kΩ, C _(load) = 10 pF		1		mA
Rise time	R _(load) = 3.3 kΩ, C _(load) = 10 pF		0.1		μs

TRF6900A SINGLE-CHIP RF TRANSCEIVER

SLAS258D – SEPTEMBER 2000 – REVISED SEPTEMBER 2001

electrical characteristics over full range of operating conditions, (typical values are at PA_VCC, PLL_VCC, DDS_VCC, DIG_VCC, DEM_VCC, MIX_VCC, LNA_VCC = 3 V, T_A = 25 °C) (unless otherwise noted) (continued)

direct digital synthesizer (DDS)

PARAMETER	TEST CONDITIONS	MIN	TYP	MAX	UNIT
Reference oscillator input frequency, f_{ref}	as oscillator	15		26	MHz
	as buffer	15		26	
Programmable DDS divider ratio	22 bits	0		4194303	
DDS divider resolution, Δf		$N \times f_{ref} \div 2^{24}$			
FSK – modulation register ratio	8 bits	0		1020	
FSK – modulation resolution		$N \times f_{ref} \div 2^{22}$			

PLL

PARAMETER	TEST CONDITIONS	MIN	TYP	MAX	UNIT
RF input frequency		850		950	MHz
RF input power	Internal VCO bypassed; external input applied to VCO_TANK2		-10		dBm
RF input divider ratio, N		256		512	
RF output frequency resolution		$N \times f_{ref} \div 2^{24}$			
Charge pump current	Programmable with external resistor, 100 k Ω nominal, APLL = 0		70		μ A

power amplifier

PARAMETER	TEST CONDITIONS	MIN	TYP	MAX	UNIT
Frequency range		850		950	MHz
Amplifier output power	0-dB attenuation	-1	4.5		dBm
	10-dB attenuation	-5	-0.5		
	20-dB attenuation	-14	-8		
	Amplifier off			-56	
Optimal load impedance		See Figure 22			Ω
2 nd -order harmonic	V _{CC} = 3 V, 0-dB attenuation		-13		dBc
3 rd -order harmonic	V _{CC} = 3 V, 0-dB attenuation		-27		dBc

typical mode switching and lock times

OPERATION	TEST CONDITIONS	MIN	TYP	MAX	UNIT
Frequency hop time between adjacent channels, during receive†	From transition of MODE to DATA_OUT valid, Channel spacing = 500 kHz, APLL = 111b (maximum)		30		μ s
Receive-to-transmit turnaround time†	From transition of MODE to valid RF signal at PA_OUT, PLL locked, 10.7 MHz RX to TX separation		200		μ s
Transmit-to-receive turnaround time†	From transition of MODE to valid data at DATA_OUT, PLL locked, 10.7 MHz RX to TX separation		200		μ s
Standby to receive time†	From rising edge of \overline{STDBY} to valid data at DATA_OUT, APLL = 111b (maximum)		600		μ s
Standby to transmit time†	From rising edge of \overline{STDBY} to valid RF signal at PA_OUT, APLL = 111b (maximum)		500		μ s

† Highly dependent upon loop filter topology.

TRF6900A SINGLE-CHIP RF TRANSCEIVER

SLAS258D – SEPTEMBER 2000 – REVISED SEPTEMBER 2001

timing data for serial interface (see Figure 2)

PARAMETER		MIN	MAX	UNIT
$f(\text{CLOCK})$	CLOCK frequency		20	MHz
$t_w(\text{CLKHI})$	CLOCK high time pulse width, CLOCK high	25		ns
$t_w(\text{CLKLO})$	CLOCK low time pulse width, CLOCK low	25		ns
$t_{su}(\text{DATA})$	Setup time, data valid before CLOCK high	25		ns
$t_h(\text{DATA})$	Hold time, data valid after CLOCK high	25		ns
$t_w(\text{STROBEHI})$	Strobe high time pulse width, STROBE high (see Note 2)	25		ns
$t_w(\text{STROBELO})$	Strobe low time pulse width, STROBE low	25		ns

NOTE 2: CLOCK and DATA must both be low when STROBE is asserted (STROBE = 1).

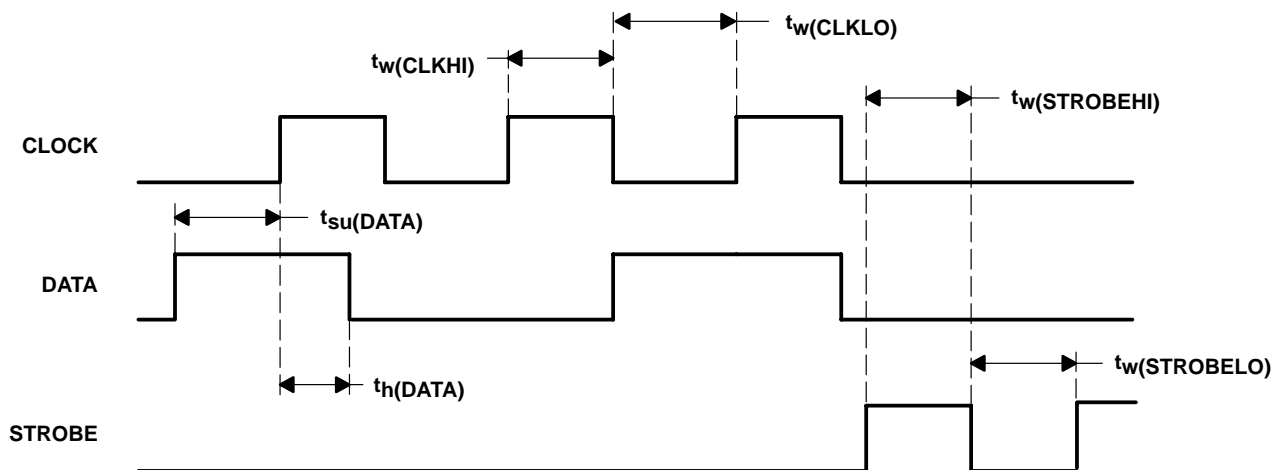

Figure 2. Serial Data Interface Timing

detailed description

low-noise amplifier

The low-noise amplifier (LNA) provides a typical gain of 13 dB and a typical noise figure of 3.3 dB.

Two operating modes, normal and low-gain mode, can be selected. The normal operation mode is selected when maximum sensitivity at low input levels is required. If high RF input levels are applied to the TRF6900A, the LNA should be operated in the low-gain mode. This ensures a minimum of nonlinear distortions in the overall receiver chain.

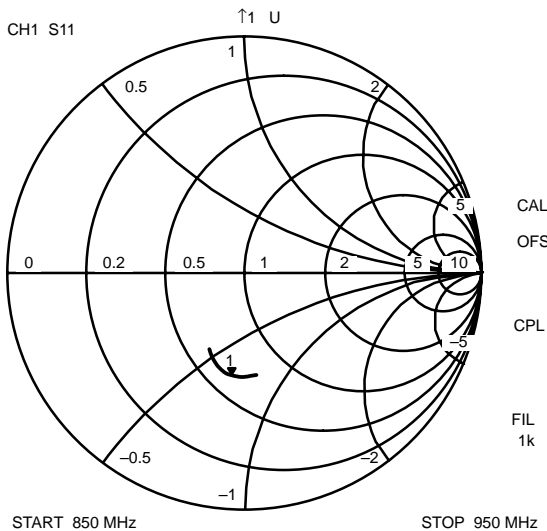

Figure 3. Typical LNA Input Impedance (S11) at Device Terminal LNA_IN

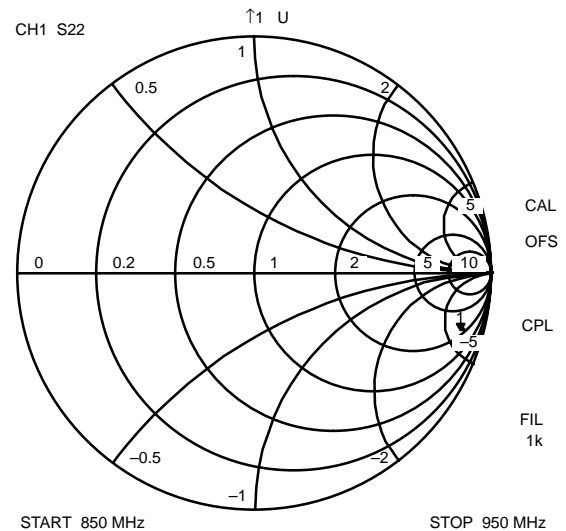

Figure 4. Typical LNA Output Impedance (S22) at Device Terminal LNA_OUT

The low impedance of the LNA input can be easily matched to 50 Ω to interface with a filter or an RF switch. At the LNA open collector output, a filter network can be used for image suppression as well as impedance matching.

RF mixer

The RF mixer is designed to operate with the on-chip VCO. If an external LO is used, a typical drive level of -10 dBm should be applied at the VCO input terminal. The mixer is a conventional double-balanced Gilbert cell mixer designed to provide a high IP3, typically 1 dBm.

Since the mixer output's push-pull amplifier has a 330- Ω output impedance, a conventional 330- Ω ceramic filter can be directly connected to the output without additional matching. The mixer output can also be directly connected to the 2nd IF amplifier/limiter input terminal, IF2_IN, through a single conventional 330- Ω ceramic filter, thus bypassing the 1st IF amplifier.

Figure 5 and Figure 6 show the RF mixer input and output impedances, respectively.

TRF6900A SINGLE-CHIP RF TRANSCEIVER

SLAS258D – SEPTEMBER 2000 – REVISED SEPTEMBER 2001

RF mixer (continued)

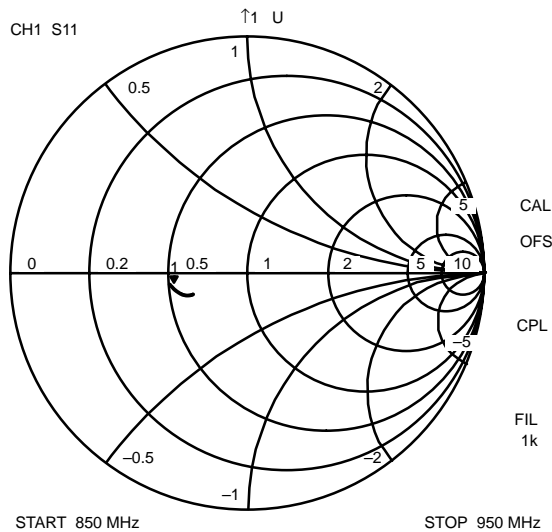

Figure 5. Typical RF Mixer Input Impedance (S11) at Device Terminal MIX_IN

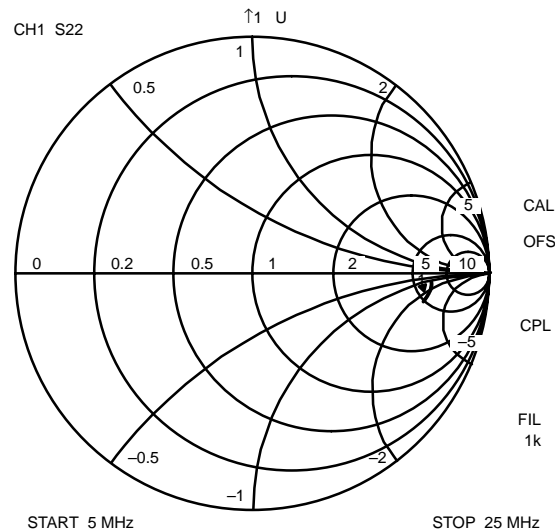

Figure 6. Typical RF Mixer Output Impedance (S22) at Device Terminal MIX_OUT

1st IF amplifier

The 1st IF amplifier provides a typical gain of 7 dB to compensate for losses caused by a ceramic filter. The input and output of the 1st IF amplifier are matched internally to 330 Ω, permitting direct connections to 330-Ω ceramic filters. If filters with different impedances are used, an impedance matching network is required.

A second filter can be connected between the 1st IF amplifier and the 2nd IF amplifier/limiter to increase the receiver selectivity. Alternately, the RF mixer output can be directly connected to the 2nd IF amplifier as shown in Figure 7. A single ceramic filter can also be used to connect terminal 41 to terminal 39. In this case, a dc-blocking capacitor of 0.1 μF should be used to connect terminal 44 to 42 to maximize receiver sensitivity.

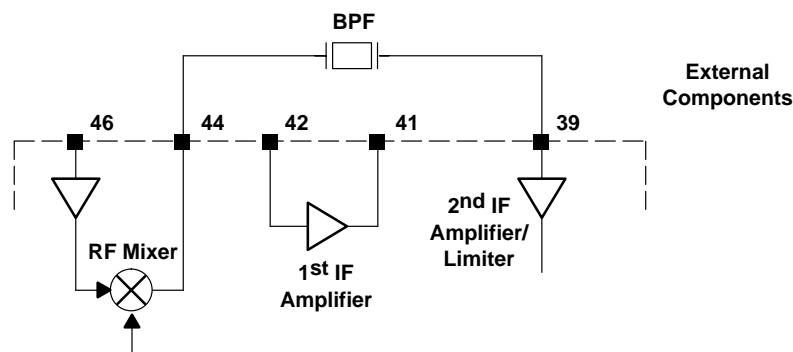

Figure 7. Bypassing the 1st IF Amplifier

Figure 8 and Figure 9 show the 1st IF amplifier input and output impedances, respectively.

1st IF amplifier (continued)

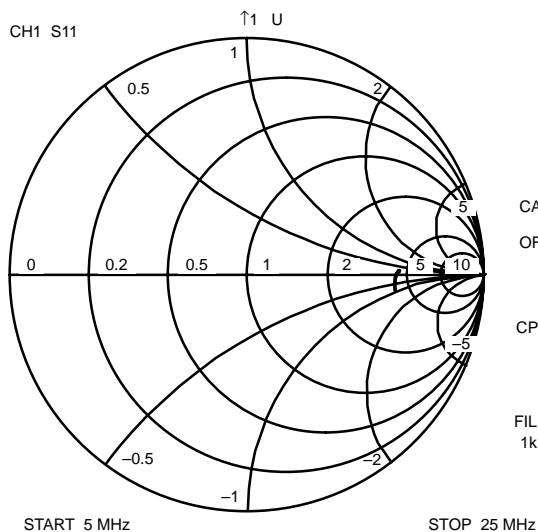

Figure 8. Typical 1st IF Amplifier Input Impedance (S11) at Device Terminal IF1_IN

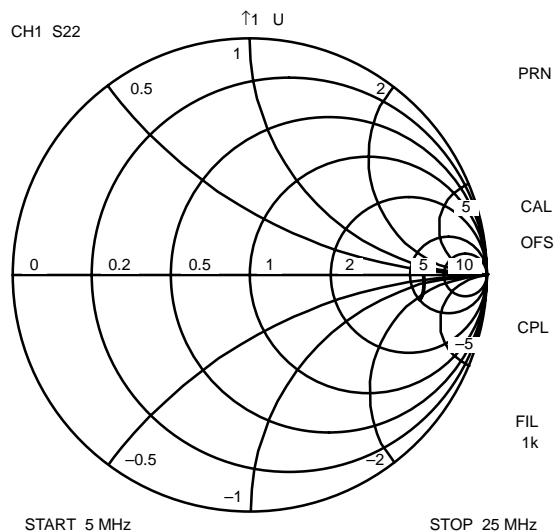

Figure 9. Typical 1st IF Amplifier Output Impedance (S22) at Device Terminal IF1_OUT

2nd IF amplifier/limiter

The 2nd IF amplifier/limiter consists of several differential amplifier stages with an overall gain of approximately 80 dB. At the IF2_IN 330-Ω input, a minimum signal level of approximately 32 μV is required to generate a limited signal at the limiter output. The limiter output is directly fed to the FM/FSK demodulator.

Figure 10 shows the 2nd IF amplifier/limiter input impedance.

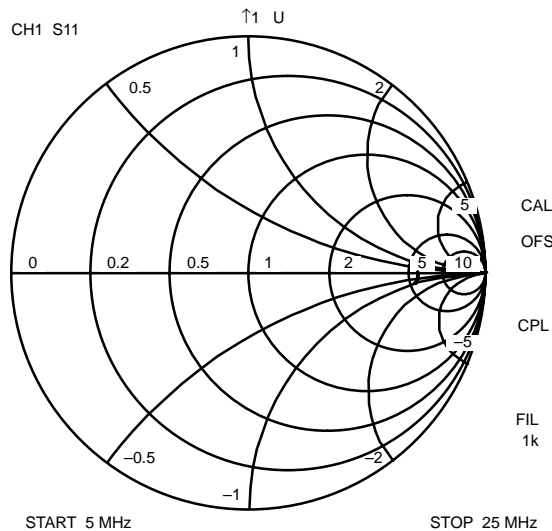

Figure 10. Typical 2nd IF Amplifier/Limiter Input Impedance (S11) at Device Terminal IF2_IN

TRF6900A SINGLE-CHIP RF TRANSCEIVER

SLAS258D – SEPTEMBER 2000 – REVISED SEPTEMBER 2001

received signal strength indicator (RSSI)

The received signal strength indicator provides a voltage at terminal 33, RSSI_OUT, that is proportional to the RF limiter input level. The slope of the RSSI circuit is typically 19 mV/dB over a frequency range of 10 MHz to 21.4 MHz. Because of its ultrafast response time (typically 1 μ s per -20 dBm to off step), the RSSI can easily be used as an amplitude-shift keying (ASK) or on/off keying (OOK) demodulator for data rates up to 100 kBit/sec.

FM/FSK demodulator

The demodulator is intended for analog (FM) and digital (FSK) frequency demodulation. It consists of a quadrature demodulator with an external LC tank circuit. A variable inductor, internal to the TRF6900A, operates in parallel with the external tank circuit (see Figure 13), and is used to adjust the external tank circuit's resonant frequency. If the tolerances of the external demodulator tank circuit components can provide a maximum frequency error of less than 5%, then no additional adjustments are required. As long as the device is in the *learning mode*, the internal reactance automatically fine-adjusts the resonant frequency of the external LC tank circuit. Depending on the supply voltage, the tank circuit tuning range is approximately four times the discriminator 3-dB bandwidth.

While in the *learning mode* i.e., during a dc-free learning sequence of 0,1,0,1,0,...., the initial tolerances of the LC demodulator tank circuit are compensated and an external capacitor (connected to terminal 29, S&H_CAP) is charged to a dc voltage that is proportional to the average demodulation dc level. This level establishes the decision threshold voltage and consequently sets the zero reference for the data slicer to generate the logical levels of the data sequence that follow the learning sequence. Therefore, the user can use a non-dc-free data signal.

The demodulator will be automatically activated if the limiter (x_LIM) and low-pass filter amplifier (x_LPF) are activated and the data switch is set to FSK/FM reception (x_SW = 0).

data switch

The TRF6900A incorporates an internal data switch used to select the input signal for the low-pass filter amplifier/post detection amplifier. Depending on the settings in the Mode0 or Mode1 enable registers (C-word, D-word), the user can select between OOK/ASK or FSK baseband processing without having to change external components.

low-pass filter amplifier/post-detection amplifier

The low-pass filter amplifier/post-detection amplifier is configured to operate as a current-to-voltage amplifier and may be used to realize a low-pass filter for post detection. The low-pass amplifier bandwidth may be adjusted according to noise and signal bandwidth requirements. An internal 10-pF capacitor sets the maximum -3 -dB corner frequency to approximately 0.75 MHz (see Figures 11 and 12).

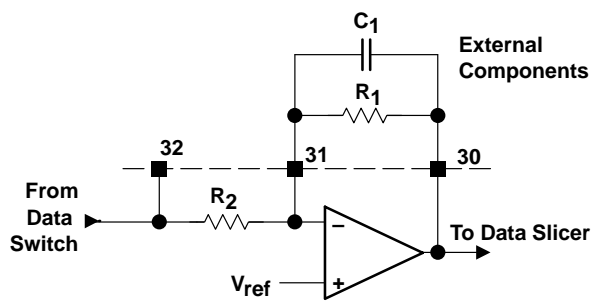

Figure 11. 1st-Order Low-Pass Filter Example

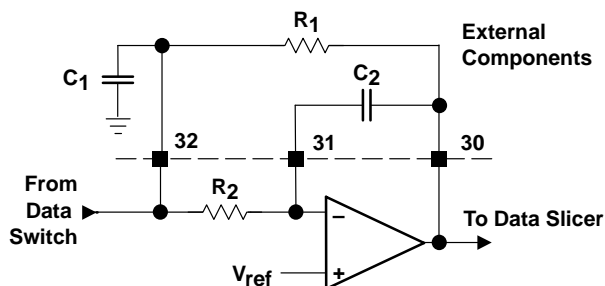

Figure 12. 2nd-Order Low-Pass Filter Example

low-pass filter amplifier/post-detection amplifier (continued)

The amplifier can be configured as a 1st- or 2nd-order low-pass filter with bandwidths that are determined by external components. The internal resistor R₂ is set to 10 kΩ, hence the –3-dB corner frequency for a 2nd-order low-pass filter (as shown in Figure 12) can be derived from the following formula:

$$f_g \cong \frac{1}{2 \times \pi \times \sqrt{10 \text{ k}\Omega \times R_1 \times C_1 \times C_2}} \quad , \text{ where } C_1 \approx 3 \times C_2$$

data slicer

The data slicer is fundamentally a comparator. The data slicer provides binary logic level signals, derived from the demodulated and low-pass filtered IF signal, that are able to drive external CMOS compatible inputs. The noninverting input is directly connected to the internal reference voltage, V_{ref}, and the inverting input is driven by the output of the low-pass filter amplifier/post-detection amplifier. The decision threshold of the data slicer is determined by the internal reference voltage, V_{ref}. The automatic frequency control (AFC) loop scheme for the TRF6900A is shown in Figure 13.

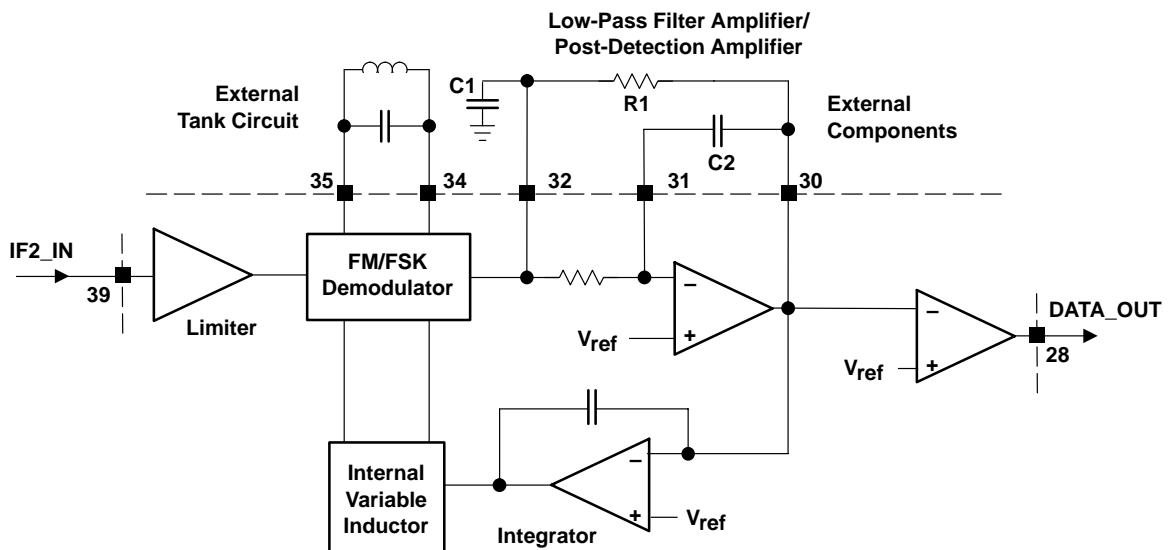

Figure 13. AFC Loop to Control the Data Slicer Decision Threshold

The integrator, acting as an error amplifier, takes the low-pass filtered output signal and generates a control voltage proportional to the frequency error of the external tank circuit as compared to the limiter output signal. By adjusting the value of the internal variable inductor, this control voltage is used to fine-tune the external tank to its nominal value.

The acquisition time of the AFC loop can be adjusted by an external capacitor connected to terminal 29, S&H_CAP. This capacitor determines the integration time constant of the integrator *while in learning mode*. As a rule of thumb, the time constant of the AFC loop should be at least five times greater than the baseband signal fundamental period.

The time constant of the entire AFC control loop can be calculated as follows:

$$\tau_{AFC} \approx 22 \text{ k}\Omega \times C_{\text{terminal 29}}$$

TRF6900A SINGLE-CHIP RF TRANSCEIVER

SLAS258D – SEPTEMBER 2000 – REVISED SEPTEMBER 2001

data slicer (continued)

The automatic frequency control loop controls the resonant frequency of the external LC tank without any additional external adjustments as long as *learning mode* operation is selected. If *hold mode* is selected, the AFC loop is open and an external dc voltage can be applied at terminal 29 to set the threshold of the data slicer. During *learning mode*, a precharged capacitor (connected to terminal 29, S&H_CAP) can be used to set the dc threshold voltage of the data slicer in *hold mode*.

In other words, the data slicer constantly integrates the incoming signal during the learning sequence (0,1,0,1. . .) and charges the external capacitor connected to terminal 29, S&H_CAP to a dc voltage level, V_{ref} , that is proportional to the average demodulation dc level. After a predefined time (dependent upon the application), the data slicer is switched to *hold mode*. The data slicer stops integrating and uses the voltage stored on the external capacitor as the decision threshold between a logic 0 or a logic 1 on the DATA_OUT terminal 28.

reference oscillator

The reference oscillator provides the DDS system clock. It allows operation, with a suitable external crystal, between 15 MHz and 26 MHz.

An external oscillator may be used to supply clock frequencies between 15 MHz and 26 MHz. The external oscillator should be directly connected to XOSC2, terminal 24. The other oscillator terminal (XOSC1, terminal 23) should be left open or can be used as a buffered version of the signal applied at terminal 24 (see Figure 14). The same crystal or externally supplied oscillator signal is used to derive both the transmit and receive frequencies.

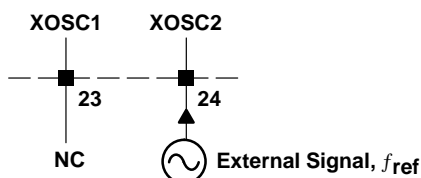

Figure 14. Applying an External Oscillator Signal

direct digital synthesizer

general principles of DDS operation

In general, a direct digital synthesizer (DDS) is based on the principle of generating a sinewave signal in the digital domain. Benefits include high precision, wide frequency range, a high degree of software programmability, and extremely fast lock times.

A block diagram of a typical DDS is shown in Figure 15. It generally consists of an accumulator, sine lookup table, a digital-to-analog converter, and a low-pass filter. All digital blocks are clocked by the reference oscillator.

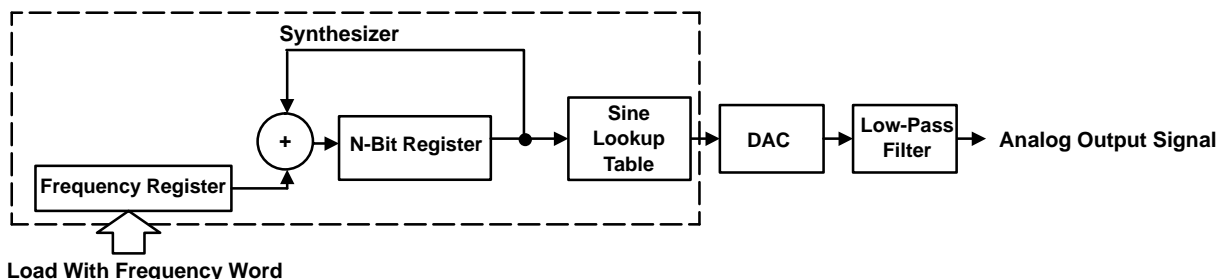

Figure 15. Typical DDS Block Diagram

general principles of DDS operation (continued)

The DDS constructs an analog sine waveform using an N-bit adder counting up from 0 to 2^N in steps of the frequency register, whereby generating a digital ramp waveform. Each number in the N-bit output register is used to select the corresponding sine wave value out of the sine lookup table. After the digital-to-analog conversion, a low-pass filter is necessary to suppress unwanted spurious responses.

The analog output signal can be used as a reference input signal for a phase locked loop. The PLL circuit then multiplies the reference frequency by a predefined factor.

TRF6900A direct digital synthesizer implementation

A block diagram of the DDS implemented in the TRF6900A is shown in Figure 16. It consists of a 24-bit accumulator clocked by the reference oscillator along with control logic settings.

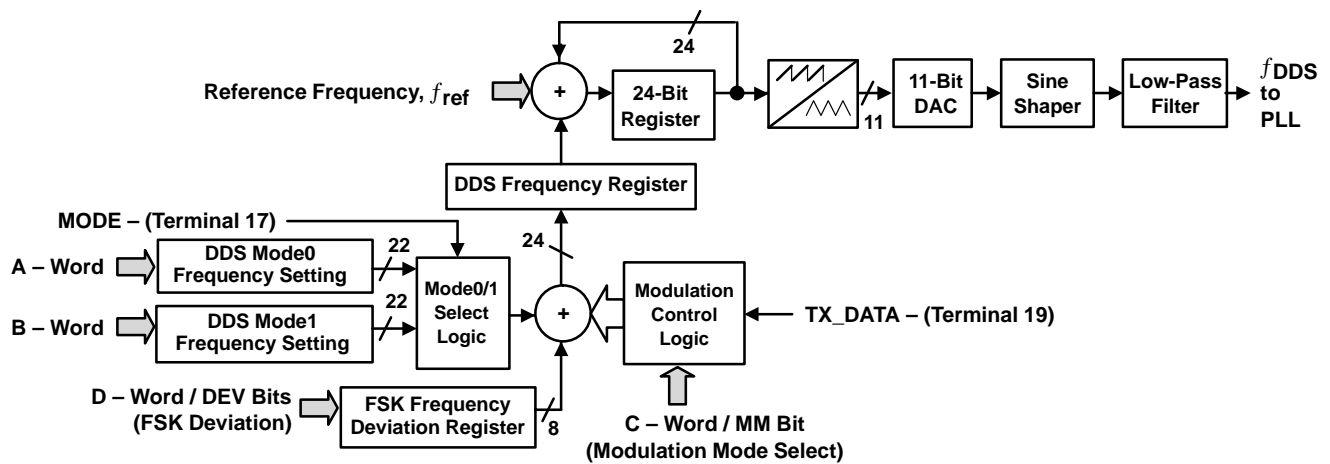

Figure 16. DDS Block Diagram as Implemented in the TRF6900A

The frequency of the reference oscillator, f_{ref} , is the DDS sample frequency, which also determines the maximum DDS output frequency. Together with the accumulator width (in bits), the frequency resolution of the DDS can be calculated. Multiplied by the divider ratio (prescaler) of the PLL, N, the minimum frequency step size of the TRF6900A is calculated as follows:

$$\Delta f = N \times \frac{f_{ref}}{2^{24}}$$

The 24-bit accumulator can be programmed via two 22-bit frequency setting registers (the A-word determines the mode0 frequency, the B-word determines the mode1 frequency) with the two MSB bits set to zero. Consequently, the maximum bit weight of the DDS system is reduced to 1/8 (see Figure 17). This bit weight corresponds to a VCO output frequency of $(f_{ref}/8) \times N$. Depending on the MODE terminal's (terminal 17) logic level, the internal mode select logic loads the frequency register with either the DDS_0 or DDS_1 frequency (see Figure 16 and Figure 17).

TRF6900A SINGLE-CHIP RF TRANSCEIVER

SLAS258D – SEPTEMBER 2000 – REVISED SEPTEMBER 2001

TRF6900A direct digital synthesizer implementation (continued)

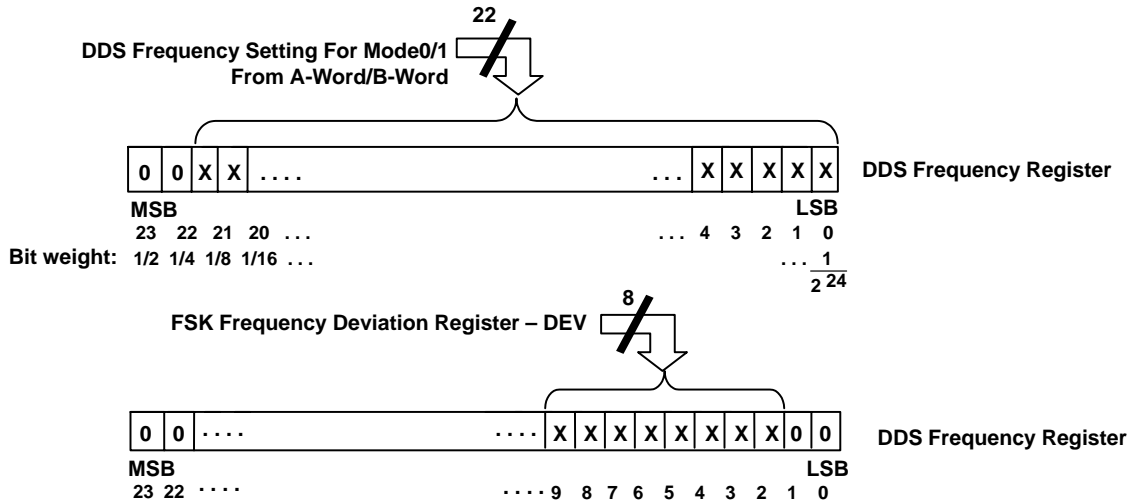

Figure 17. Implementation of the DDS Frequency and FSK Frequency Deviation in the DDS Frequency Register

The VCO output frequency, f_{out} , which is dependent on the DDS_x frequency settings (DDS_0 in the A-word or DDS_1 in the B-word), can be calculated as follows:

$$f_{out} = \text{DDS}_x \times N \times \frac{f_{ref}}{2^{24}} = N \times \frac{f_{ref} \times \text{DDS}_x}{2^{24}}$$

If FSK modulation is selected (MM=0; C-Word, bit 16) the 8-bit FSK deviation register can be used to program the frequency deviation of the 2-FSK modulation. Figure 17 illustrates where the 8 bits of the FSK deviation register map into the 24-bit DDS frequency register. Since the two LSBs are set to zero, the total FSK deviation can be determined as follows:

$$\Delta f_{2\text{-FSK}} = N \times \frac{\text{DEV} \times f_{ref}}{2^{22}}$$

Hence, the 2-FSK frequency, set by the level of TX_DATA, is calculated as follows:

$$f_{out1:\text{TX_DATA=Low}} = N \times \frac{f_{ref} \times \text{DDS}_x}{2^{24}} \quad f_{out2:\text{TX_DATA=High}} = N \times \frac{f_{ref} \times (\text{DDS}_x + 4 \times \text{DEV})}{2^{24}}$$

This frequency modulated output signal is used as a reference input signal for the PLL circuit.

Note that the frequencies f_{out1} and f_{out2} are centered about the frequency $f_{center} = (f_{out1} + f_{out2})/2$. When transmitting FSK, f_{center} is considered to be the effective carrier frequency and any receiver local oscillator (LO) should be set to the same f_{center} frequency \pm the receiver's IF frequency (f_{IF}) for proper reception and demodulation.

For the case of low-side injection, the receiver LO would be set to $f_{LO} = f_{center} - f_{IF}$. Using low-side injection, the received data at terminal 28, DATA_OUT, would be inverted from the transmitted data applied at terminal 19, TX_DATA. Conversely, for high-side injection, the receiver LO would be set to $f_{LO} = f_{center} + f_{IF}$. Using high-side injection, the received data would be the same as the transmitted data.

In addition, when the TRF6900A is placed in receive mode, it is recommended that the TX_DATA terminal be kept low. In this manner, the actual LO frequency injected into the mixer is $f_{out1} = f_{LO}$. If TX_DATA is set high, the contents of the deviation register would offset the receiver LO resulting in poor receiver sensitivity.

TRF6900A direct digital synthesizer implementation (continued)

Channel width (frequency deviation) for 2-FSK modulation and channel spacing are software programmable. The minimum channel width and minimum channel spacing depend on the RF system frequency plan.

Since the DDS registers are static, preprogrammed values are retained during standby mode. This feature greatly reduces turnon time, reduces current consumption when coming out of standby mode, and enables very fast lock-times. The PLL lock-times ultimately determine when data can be transmitted or received.

phase-locked loop

The phase-locked loop (PLL) of the TRF6900A consists of a phase detector (PD) and a frequency acquisition aid (FD), two charge pumps, an external loop filter, a voltage controlled oscillator (VCO), and a programmable fixed prescaler (N-divider) in the feedback loop (see Figure 18).

The PLL as implemented in the TRF6900A multiplies the DDS output frequency and further suppresses the unwanted spurious signals produced by the direct digital synthesizer.

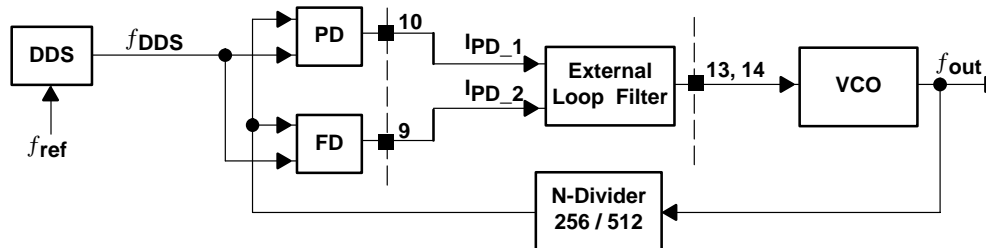

Figure 18. Basic PLL Structure

VCO

A modified Colpitts oscillator architecture with an external resonant circuit is used for the TRF6900A. The internal bias current network adjusts the signal amplitude of the VCO. This allows a wide range of Q-factors (30...60) for the external tank circuit.

The VCO can be bypassed by applying an external RF signal at VCO_TANK2, terminal 14. To drive the internal PLL and power amplifier, a typical level of -10 dBm should be applied. When an external VCO is used, the x_VCO bit should be set to 0.

phase detector and charge pumps

The TRF6900A contains two charge pumps for locking to the desired frequency: one for coarse tuning of the frequency differences (called the frequency acquisition aid), and one for fine tuning of the phase differences (used in conjunction with the phase detector).

The XOR phase detector and charge pumps produce a mean output current that is proportional to the phase difference between the reference frequency and the VCO frequency divided by N; N=256 or 512. The TRF6900A generates the current pulses I_PD_1 during normal operation (PLL locked).

An additional slip detector and acquisition aid charge pump generates current pulses at terminal PD_OUT2 during the lock-in of the PLL. This charge pump is turned off when the PLL locks in order to reduce current consumption. The multiplication factor of the acquisition aid current I_PD_2 can be programmed by three bits (APLL) in the C-word.

The slip detector output, PD_OUT2, at terminal 9 should be connected directly to the loop filter capacitor C₁, as in Figure 21. The nominal charge pump current I₀ is determined by the external resistor R_{PD}, connected to terminal 8, and can be calculated as follows:

$$I_0 = \frac{7V}{R_{PD}}$$

TRF6900A SINGLE-CHIP RF TRANSCEIVER

SLAS258D – SEPTEMBER 2000 – REVISED SEPTEMBER 2001

phase detector and charge pumps (continued)

During normal operation (PLL locked), the acquisition aid charge pump is disabled and the maximum charge pump current I_{PD_1} is determined by the nominal value I_0 (see Figure 19).



Figure 19. Normal Operation Charge Pump Current, I_{PD_1}

Each time the PLL is in an unlocked condition, the acquisition aid charge pump generates current pulses I_{PD_2} . The I_{PD_2} current pulses are APLL times larger than I_0 (see Figure 20).

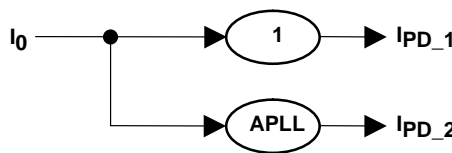

Figure 20. Acquisition Aid, I_{PD_2} , and Normal Operation, I_{PD_1} , Charge Pump Currents

programmable divider

The internal divider ratio, N , can be set to 256 or 512 via the C-word. Since a higher divider ratio adds additional noise within the multiplication loop, the lowest divider ratio possible for the target application should be used.

loop filter

Loop filter designs are a balance between lock-time, noise, and spurious suppression. For the TRF6900A, common loop filter design rules can be used to determine an appropriate low-pass filter. Standard formulas can be used as a first approach to calculate a basic loop filter. Figure 21 illustrates a basic 3rd-order loop filter.

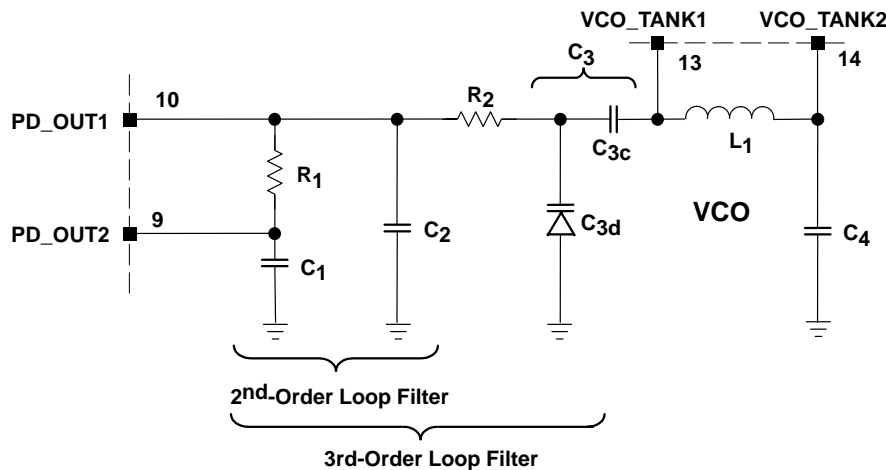

Figure 21. Basic 3rd-Order Loop Filter Structure

For maximum suppression of the unwanted frequency components, the loop filter bandwidth should generally be made as narrow as possible. At the same time, the filter bandwidth has to be wide enough to allow for the 2-FSK modulation and appropriate lock-time. A detailed simulation of the phase-locked loop should be performed and later verified on PCB implementations.

power amplifier

The power amplifier (PA) can be programmed via two bits (P0 and P1 in the D-word) to provide varying output power levels. Several control loops are implemented internally to set the output power and to minimize the sensitivity of the power amplifier to temperature, load impedance, and power supply variations. The output stage of the PA usually operates in Class-C and enables easy impedance matching. PA_OUT, terminal 5, is an open collector output terminal.

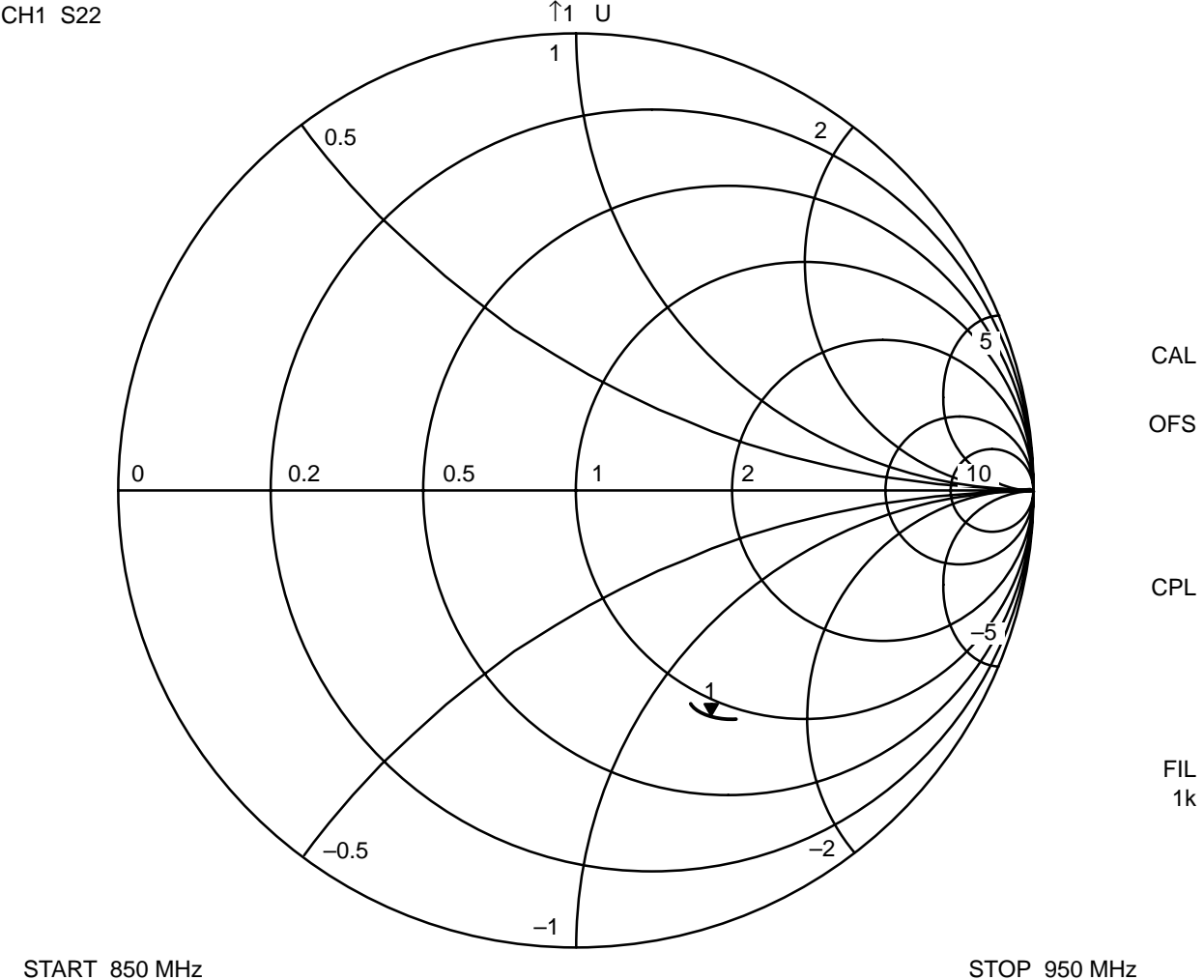

Figure 22. Power Amplifier Output Impedance (S22) at Device Terminal 5

TRF6900A SINGLE-CHIP RF TRANSCEIVER

SLAS258D – SEPTEMBER 2000 – REVISED SEPTEMBER 2001

PRINCIPLES OF OPERATION

serial control interface

A 3-wire unidirectional serial bus (CLOCK, DATA, STROBE) is used to program the TRF6900A (see Figure 23). The internal registers contain all user programmable variables including the DDS frequency setting registers as well as all control registers.

At each rising edge of the CLOCK signal, the logic value on the DATA terminal is written into a 24-bit shift register. Setting the STROBE terminal high loads the programmed information into the selected latch. While the STROBE signal is high, the DATA and CLOCK lines must be low (see Figure 2). Since the CLOCK and STROBE signals are asynchronous, care should be taken to ensure these signals remain free of glitches and noise.

As additional leading bits are ignored, only the least significant 24 bits are serial-clocked into the shift register. Due to the static CMOS design, the serial interface consumes virtually no current and it can be programmed in active as well as in standby mode.

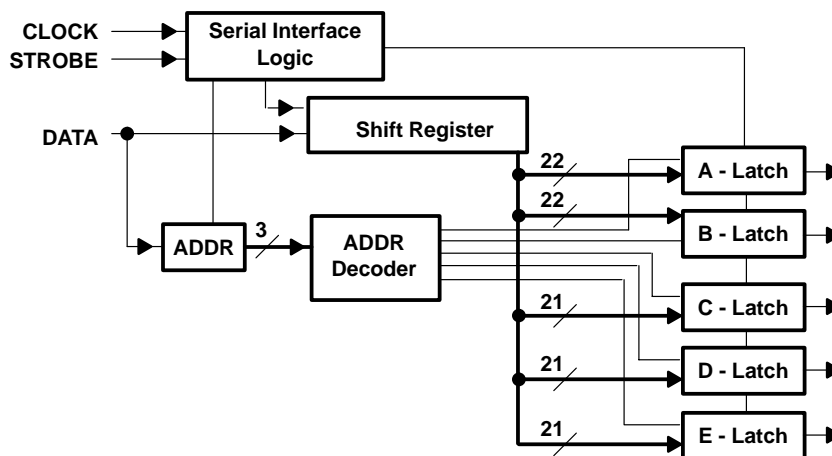

Figure 23. Serial Interface Block Diagram

The control words are 24 bits in length. The first incoming bit functions as the most significant bit (MSB).

To fully program the TRF6900A, four 24-bit words must be sent: the A-, B-, C-, and D-word. If individual bits within a word are to be changed, then it is sufficient to program only the appropriate 24-bit word.

The definition of the control words are illustrated in Figure 24. Tables 1, 2, and 3 describe the function of each parameter.

The E-Latch, addressed by an ADDR equal to 111, is reserved for test purposes and should not be used. Inadvertently addressing the E-Latch activates the test modes of the TRF6900A.

If the test mode has been inadvertently activated, it can only be exited by switching V_{CC} on and off or by clearing the E-Latch. The E-Latch can be cleared by addressing it and resetting its entire contents by programming 1110 0000 0000 0000 0000 0000.

As part of a proper power-up sequence, it is recommended to clear the E-Latch each time V_{CC} is applied before starting further operations with the TRF6900A.

PRINCIPLES OF OPERATION

A-Word (Programming of DDS_0)

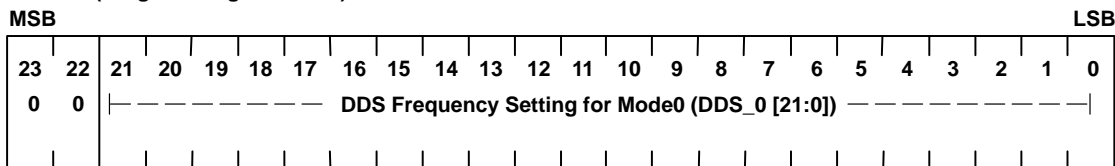

ADDR

B-Word (Programming of DDS_1)

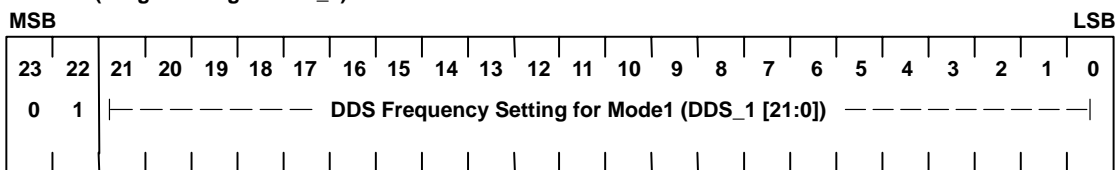

ADDR

C-Word (Control Register for PLL, Data Slicer and Mode1 Settings)

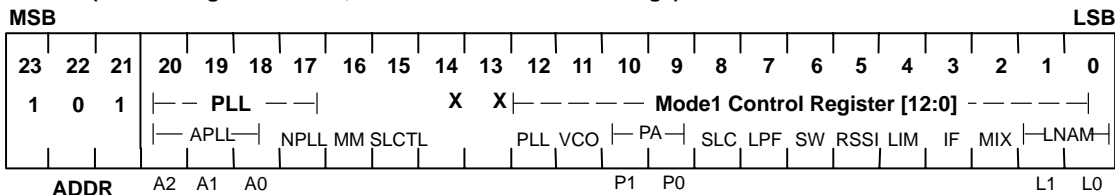

D-Word (Control Register for Modulation and Mode0 Settings)

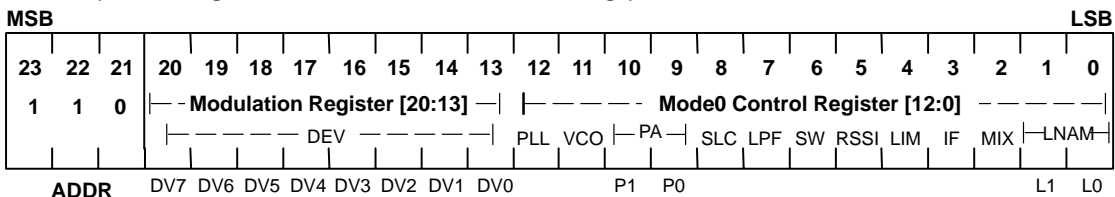

NOTE: Start programming with MSB and ensure that the CLOCK and DATA lines are low during the rising edge of the strobe signal.

Figure 24. Serial Control Word Format

TRF6900A SINGLE-CHIP RF TRANSCEIVER

SLAS258D – SEPTEMBER 2000 – REVISED SEPTEMBER 2001

PRINCIPLES OF OPERATION

Table 1. Mode0 Control Register Description (D-Word)

SYMBOL	BIT LOCATION	NUMBER OF BITS	DESCRIPTION	INITIAL SETTINGS AFTER POWER-UP	
				DEFAULT STATE	DEFAULT VALUE
0_LNAM	[1:0]	2	Low-noise amplifier operation mode L1 L0 0 0 : LNA disabled 0 1 : LNA enable – low-gain mode 1 0 : LNA disabled 1 1 : LNA enable – normal operation mode	Disabled	00b
0_MIX	[2]	1	Enable mixer 1: enabled 0: disabled	Disabled	0b
0_IF	[3]	1	Enable 1 st IF amplifier 1: enabled 0: disabled	Disabled	0b
0_LIM	[4]	1	Enable limiter 1: enabled 0: disabled	Disabled	0b
0_RSSI	[5]	1	Enable RSSI 1: enabled 0: disabled	Disabled	0b
0_SW	[6]	1	Data switch 0 : LPF amplifier input routed to demodulator (FSK/FM) 1 : LPF amplifier input routed to RSSI (OOK/ASK)	Routed to Demodulator	0b
0_LPF	[7]	1	Enable LPF amplifier 1: enabled 0: disabled	Disabled	0b
0_SLC	[8]	1	Enable data slicer 1: enabled 0: disabled	Disabled	0b
0_PA	[10:9]	2	Power amplifier mode P1 P0 0 0 : disabled 0 1 : 10-dB attenuation, enable modulation via TX_DATA 1 0 : 20-dB attenuation, enable modulation via TX_DATA 1 1 : 0-dB attenuation, enable modulation via TX_DATA	Disabled	00b
0_VCO	[11]	1	During operation, this bit should always be enabled (1: enabled), unless an external VCO is used.	Disabled	0b
0_PLL	[12]	1	Enable PLL (DDS system, RF, VCO, divider, phase comparator and charge pump) 1: enabled 0: disabled	Disabled	0b

NOTE: The FM/FSK demodulator is automatically enabled if the limiter and low-pass amplifier are enabled and the data switch is set to FSK reception.

TRF6900A SINGLE-CHIP RF TRANSCEIVER

SLAS258D – SEPTEMBER 2000 – REVISED SEPTEMBER 2001

PRINCIPLES OF OPERATION

Table 2. Mode1 Control Register Description (C-Word)

SYMBOL	BIT LOCATION	NUMBER OF BITS	DESCRIPTION	INITIAL SETTINGS AFTER POWER-UP	
				DEFAULT STATE	DEFAULT VALUE
1_LNAM	[1:0]	2	Low-noise amplifier operation mode L1 L0 0 0 : LNA disabled 0 1 : LNA enable – low-gain mode 1 0 : LNA disabled 1 1 : LNA enable – normal operation mode	Disabled	00b
1_MIX	[2]	1	Enable mixer 1: enabled 0: disabled	Disabled	0b
1_IF	[3]	1	Enable 1 st IF amplifier 1: enabled 0: disabled	Disabled	0b
1_LIM	[4]	1	Enable limiter 1: enabled 0: disabled	Disabled	0b
1_RSSI	[5]	1	Enable RSSI 1: enabled 0: disabled	Disabled	0b
1_SW	[6]	1	Data switch 0 : LPF amplifier input routed to demodulator (FSK/FM) 1 : LPF amplifier input routed to RSSI (OOK/ASK)	Routed to Demodulator	0b
1_LPF	[7]	1	Enable LPF amplifier 1: enabled 0: disabled	Disabled	0b
1_SLC	[8]	1	Enable data slicer 1: enabled 0: disabled	Disabled	0b
1_PA	[10:9]	2	Power amplifier mode P1 P0 0 0 : disabled 0 1 : 10-dB attenuation, enable modulation via TX_DATA 1 0 : 20-dB attenuation, enable modulation via TX_DATA 1 1 : 0-dB attenuation, enable modulation via TX_DATA	Disabled	00b
1_VCO	[11]	1	During operation, this bit should always be enabled (1: enabled), unless an external VCO is used.	Disabled	0b
1_PLL	[12]	1	Enable PLL (DDS system, VCO, RF divider, phase comparator and charge pump) 1: enabled 0: disabled	Disabled	0b

NOTE: The FM/FSK demodulator is automatically enabled if the limiter and low-pass amplifier are enabled and the data switch is set to FSK reception.

TRF6900A SINGLE-CHIP RF TRANSCEIVER

SLAS258D – SEPTEMBER 2000 – REVISED SEPTEMBER 2001

PRINCIPLES OF OPERATION

Table 3. Miscellaneous Control Register Description

SYMBOL	WORD	BIT LOCATION	NUMBER OF BITS	DESCRIPTION	INITIAL SETTINGS AFTER POWER-UP	
					DEFAULT STATE	DEFAULT VALUE
DDS_0	A-word	[21:0]	22	DDS frequency setting in Mode0	Zero	All zeroes
DDS_1	B-word	[21:0]	22	DDS frequency setting in Mode1	Zero	All zeroes
DEV	D-word	[20:13]	8	FSK frequency deviation register	Zero	All zeroes
SLCTL	C-word	[15]	1	Slicer mode select bit 0 : hold mode 1 : learning mode	Hold mode	0b
APLL	C-word	[20:18]	3	Acceleration factor for the frequency acquisition aid charge pump A2 A1 A0 0 0 0 : 1 0 0 1 : 20 0 1 0 : 40 0 1 1 : 60 : 1 1 1 : 140	Zero	000b
NPLL	C-word	[17]	1	PLL divider ratio 0 : 256 1 : 512	256	0b
MM	C-word	[16]	1	Modulation mode select. Sets the behavior of pin TX_DATA to FSK data input. 0 : FSK/FM 1 : Do not use	FSK mode	0b

operating modes

Tables 4 and 5 illustrate operating modes and transmit frequencies as set by the $\overline{\text{STDBY}}$, MODE and TX_DATA terminals used in conjunction with the DDS frequency settings.

Table 4. Transmitting Data in FSK Mode (MM bit set to 0)

TERMINAL			TRANSMIT FREQUENCY
$\overline{\text{STDBY}}$	MODE	TX_DATA	
1	0	0	$f_{\text{out}} = f_{\text{ref}} \times N \times (\text{DDS}_0) / 2^{24}$
1	0	1	$f_{\text{out}} = f_{\text{ref}} \times N \times (\text{DDS}_0 + 4 \times \text{DEV}) / 2^{24}$
1	1	0	$f_{\text{out}} = f_{\text{ref}} \times N \times (\text{DDS}_1) / 2^{24}$
1	1	1	$f_{\text{out}} = f_{\text{ref}} \times N \times (\text{DDS}_1 + 4 \times \text{dev}) / 2^{24}$

Table 5. Operating Mode Per $\overline{\text{STDBY}}$ Terminal

$\overline{\text{STDBY}}$	OPERATING MODE
0	Standby/programming mode – power down of all blocks
1	Operating mode and programming mode

Two independent operating modes, Mode0 and Mode1, allow extremely fast switching between two preprogrammed settings by toggling the MODE terminal. Each mode can be viewed as a bank of configuration registers which store the frequency settings and the enable/disable settings for each functional block of the TRF6900A. The MODE terminal is then used to asynchronously switch between Mode0 and Mode1 as shown in Figure 25. Several examples of operating sequences are shown in Table 6.

PRINCIPLES OF OPERATION

operating modes (continued)

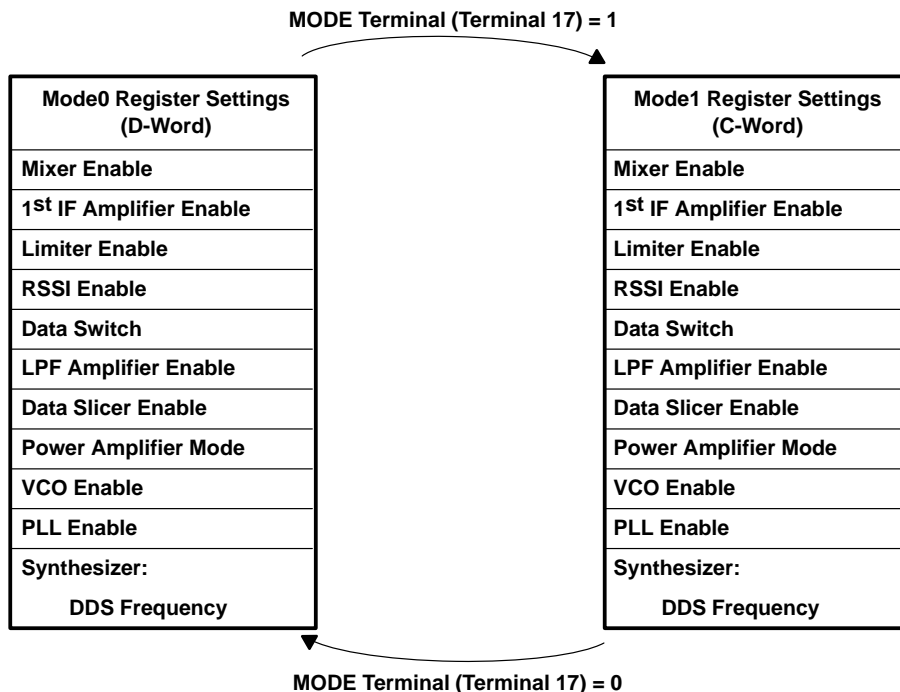

Figure 25. Interaction Between MODE Terminal and Preprogrammed Mode0 and Mode1 Control Registers

Table 6. Operating Mode Examples

FUNCTION/DESCRIPTION	MODE0	MODE1
Receive polling with frequency hopping, or scan band	Receive on frequency 0	Receive on frequency 1
Transmit and receive on different frequencies	Transmit on frequency 0	Receive on frequency 1
Broadcast on one frequency and receive on another	Transmit on frequency 0 (broadcast channel)	Receive on frequency 1
Rapid switch between receive and power saving mode (keep DDS/VCO running)	Receive on frequency 0	All blocks off except DDS, VCO, and PLL
Emulate FSK transmit operation using the MODE terminal for wideband FSK	Transmit on frequency 0	Transmit on frequency 0 + deviation

TRF6900A SINGLE-CHIP RF TRANSCEIVER

SLAS258D – SEPTEMBER 2000 – REVISED SEPTEMBER 2001

PRINCIPLES OF OPERATION

operating modes (continued)

Figure 26 illustrates how the user of the TRF6900A can preload the serial control words while in standby/programming mode and then receive baseband data while in operating mode.

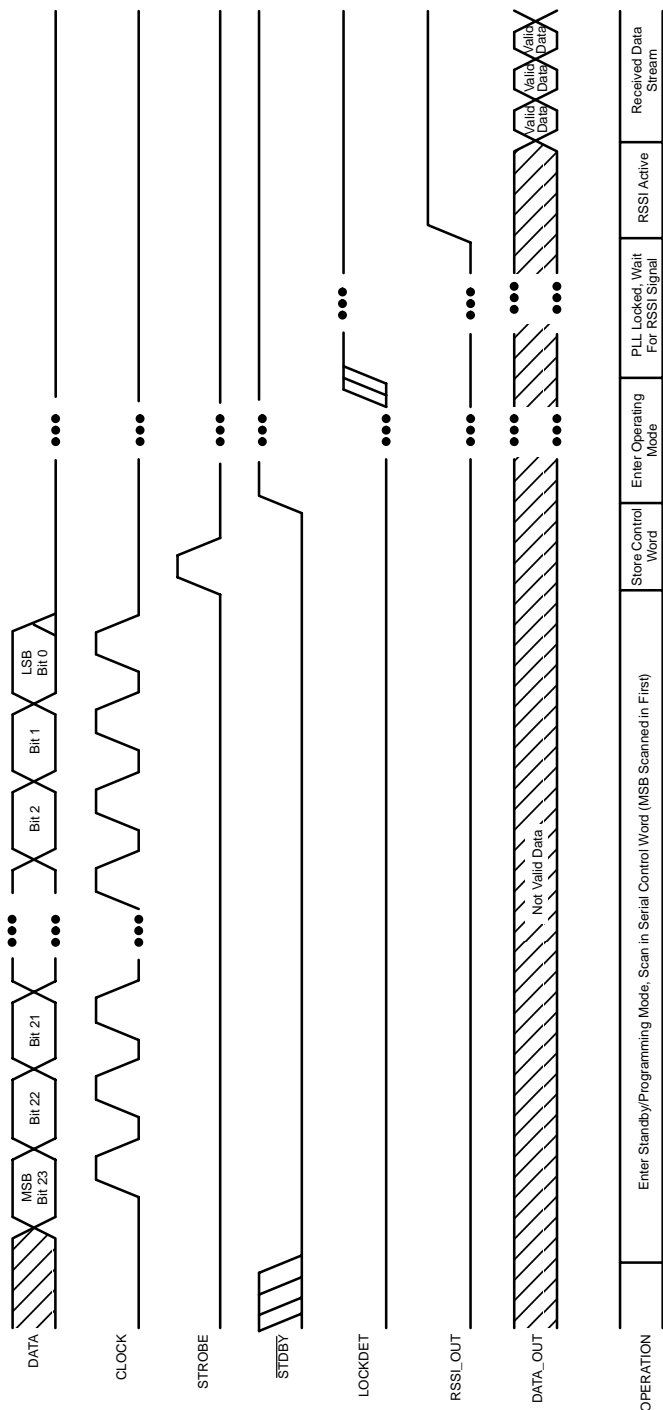

Figure 26. Preloading Serial Control Word and Receiving Baseband Data

TRF6900A SINGLE-CHIP RF TRANSCEIVER

SLAS258D – SEPTEMBER 2000 – REVISED SEPTEMBER 2001

APPLICATION INFORMATION

A typical application schematic for an FSK system operating in the 868-MHz to 870-MHz European ISM band is shown in Figure 27.

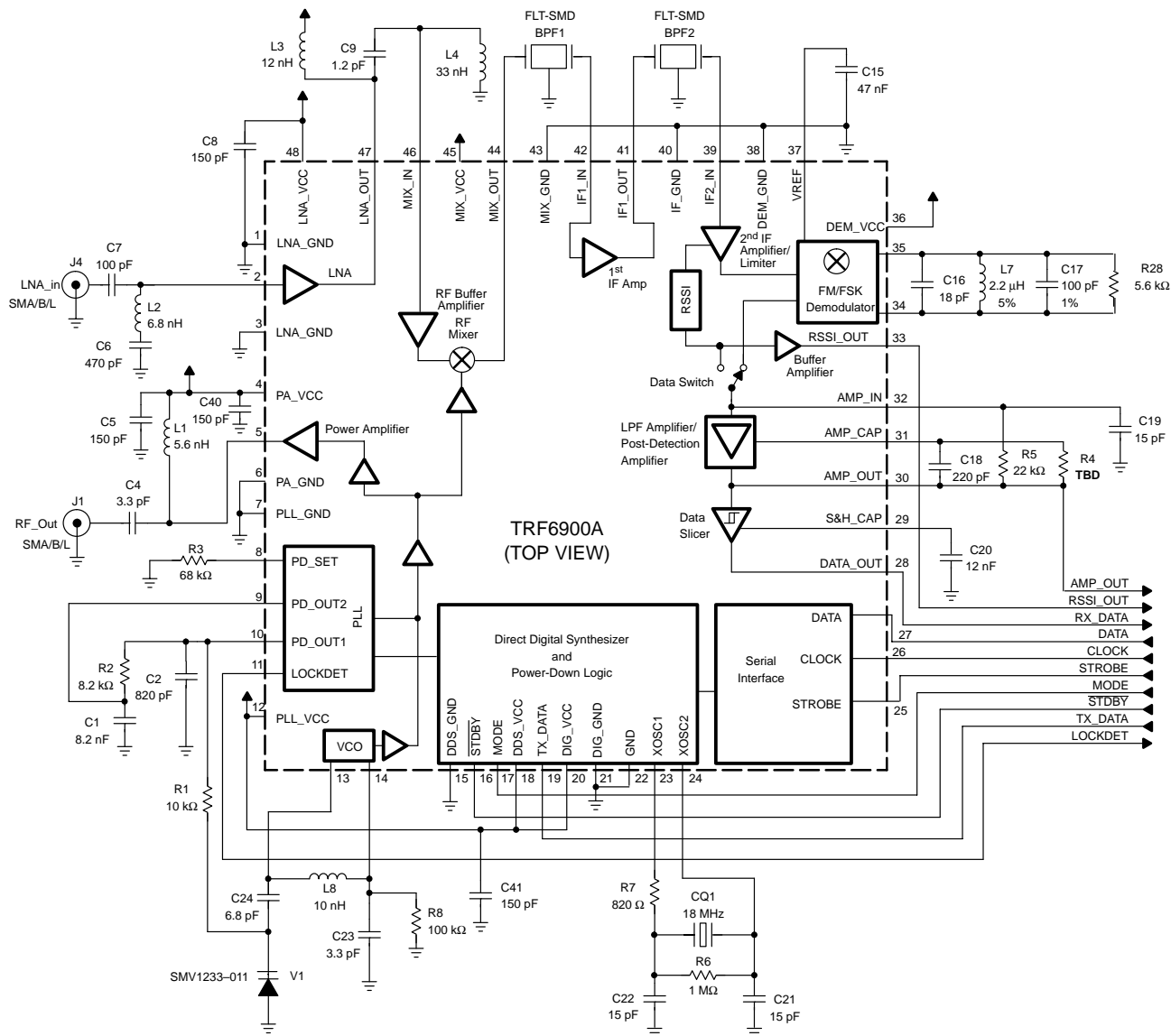

Figure 27. Typical Application Schematic for 868-MHz to 870-MHz European ISM Band

TRF6900A SINGLE-CHIP RF TRANSCEIVER

SLAS258D – SEPTEMBER 2000 – REVISED SEPTEMBER 2001

APPLICATION INFORMATION

external component list (5% tolerance unless otherwise noted) for Figure 27

DESIGNATOR	DESCRIPTION (SIZE)	VALUE	MANUFACTURER	PART NUMBER/COMMENTS
C1	Capacitor	8.2 nF		
C2	Capacitor	820 pF		
C4	Capacitor	3.3 pF		
C5	Capacitor	150 pF		
C6	Capacitor	470 nF		
C7	Capacitor	100 pF		
C8	Capacitor	150 pF		
C9	Capacitor	1.2 pF		
C15	Capacitor	47 nF		
C16	Capacitor	18 nF		
C17	Capacitor	100 pF		1% tolerance
C18	Capacitor	220 pF		
C19	Capacitor	15 pF		
C20	Capacitor	12 nF		
C21	Capacitor	15 pF		
C22	Capacitor	15 pF		
C23	Capacitor	3.3 pF		
C24	Capacitor	6.8 pF		
C40	Capacitor	150 pF		
C41	Capacitor	150 pF		
L1	Coil	5.6 nH	Murata	LQW1608
L2	Coil	6.8 nH	Murata	LQW1608
L3	Coil	12 nH	Murata	LQW1608
L4	Coil	33 nH	Murata	LQW1608
L7	Coil	2.2 μH	Murata	LQH1N2RZJ04, 5% tolerance
L8	Coil	10 nH	Murata	LQW1608, 5% tolerance
R1	Resistor	10 kΩ		
R2	Resistor	8.2 kΩ		
R3	Resistor	68 kΩ		
R4	Resistor	Optional		
R5	Resistor	22 kΩ		
R6	Resistor	1 MΩ		
R7	Resistor	820 Ω		
R8	Resistor	100 kΩ		
R28	Resistor	5.6 kΩ		
V1	Varactor diode	SMV1233-011	Alpha Industries	
CQ1	Crystal	18 MHz	CMAC Frequency Products	CX-1 SMI
BPF1	Filter		Murata	SFECV10.7MJ-Z, 10.7-MHz IF filter
BPF2	Filter		Murata	SFECV10.7MJ-Z, 10.7-MHz IF filter

TRF6900A SINGLE-CHIP RF TRANSCEIVER

SLAS258D – SEPTEMBER 2000 – REVISED SEPTEMBER 2001

APPLICATION INFORMATION

A typical application schematic for an FSK system operating in the 902-MHz to 928-MHz North American ISM band is shown in Figure 28.

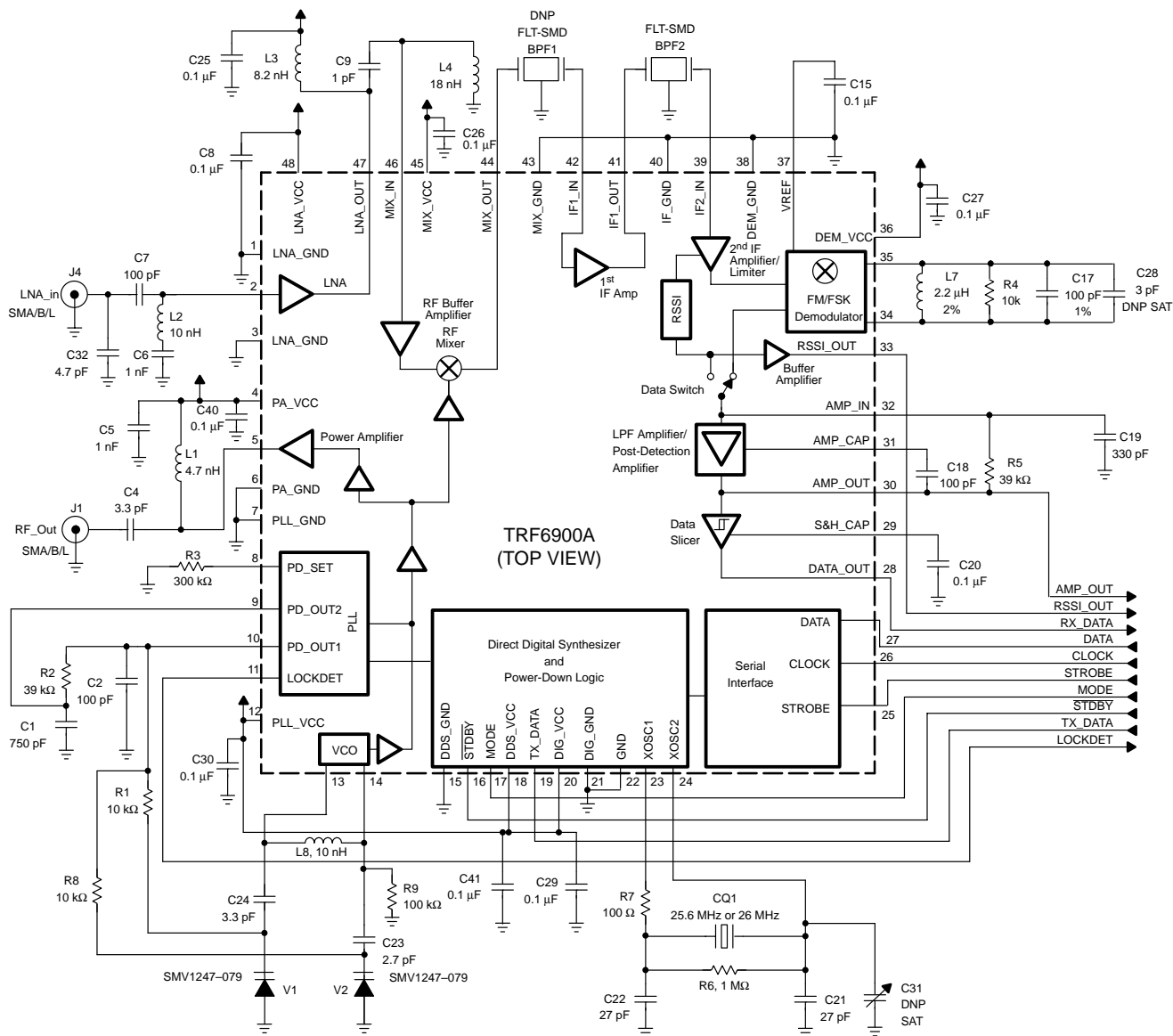

Figure 28. Typical Application Schematic for 902 to 928 MHz North American ISM Band

external component list (5% tolerance unless otherwise noted) for Figure 28

DESIGNATOR	DESCRIPTION (SIZE)	VALUE	MANUFACTURER	PART NUMBER/COMMENTS
C1	Capacitor	750 pF		
C2	Capacitor	100 pF		
C3	Capacitor	0.5 pF		
C4	Capacitor	3.3 pF		

TRF6900A SINGLE-CHIP RF TRANSCEIVER

SLAS258D – SEPTEMBER 2000 – REVISED SEPTEMBER 2001

APPLICATION INFORMATION

external component list (5% tolerance unless otherwise noted) for Figure 28 (continued)

DESIGNATOR	DESCRIPTION (SIZE)	VALUE	MANUFACTURER	PART NUMBER/COMMENTS
C5	Capacitor	1 nF		
C6	Capacitor	1 nF		
C7	Capacitor	100 pF		
C8	Capacitor	0.1 μ F		
C9	Capacitor	1 pF		
C15	Capacitor	0.1 μ F		
C17	Capacitor	100 pF		1% tolerance
C18	Capacitor	100 pF		
C19	Capacitor	330 pF		
C20	Capacitor	0.1 μ F		
C21	Capacitor	27 pF		
C22	Capacitor	27 pF		
C23	Capacitor	2.7 pF		
C24	Capacitor	3.3 pF		
C25	Capacitor	0.1 μ F		
C26	Capacitor	0.1 μ F		
C27	Capacitor	0.1 μ F		
C28	Capacitor	3 pF		Select at test (SAT), Do not place (DNP)
C29	Capacitor	0.1 μ F		
C30	Capacitor	0.1 μ F		
C31	Capacitor			Select at test (SAT), Do not place (DNP)
C32	Capacitor	4.7 pF		
C40	Capacitor	0.1 μ F		
C41	Capacitor	150 pF		
L1	Coil	4.7 nH	Murata	LQW1608
L2	Coil	10 nH	Murata	LQW1608
L3	Coil	8.2 nH	Murata	LQW1608
L4	Coil	18 nH	Murata	LQW1608
L7	Coil	2.2 μ H	Murata	LQS33N2R2G04M00, 2% tolerance
L8	Coil	10 nH	Murata	LQW1608, 5% tolerance
R1	Resistor	10 k Ω		
R2	Resistor	39 k Ω		
R3	Resistor	300 k Ω		
R4	Resistor	10 k Ω		
R5	Resistor	39 k Ω		
R6	Resistor	1 M Ω		
R7	Resistor	100 Ω		
R8	Resistor	10 k Ω		
R9	Resistor	100 k Ω		
V1, V2	Varactor diode	SMV1247-079	Alpha Industries	
CQ1	Crystal	25.6 MHz or 26 MHz	ICM (International Crystal Manufacturing, Incorporated)	865842: 25.6 MHz 865850: 26 MHz
BPF1	Filter		Murata	SFECV10.7H-A, 10.7-MHz IF filter, DNP. If not used, replace with 0.1- μ F capacitor.
BPF2	Filter		Murata	SFECV10.7H-A, 10.7-MHz IF filter

TRF6900A SINGLE-CHIP RF TRANSCEIVER

SLAS258D – SEPTEMBER 2000 – REVISED SEPTEMBER 2001

MECHANICAL DATA

PT (S-PQFP-G48)

PLASTIC QUAD FLATPACK

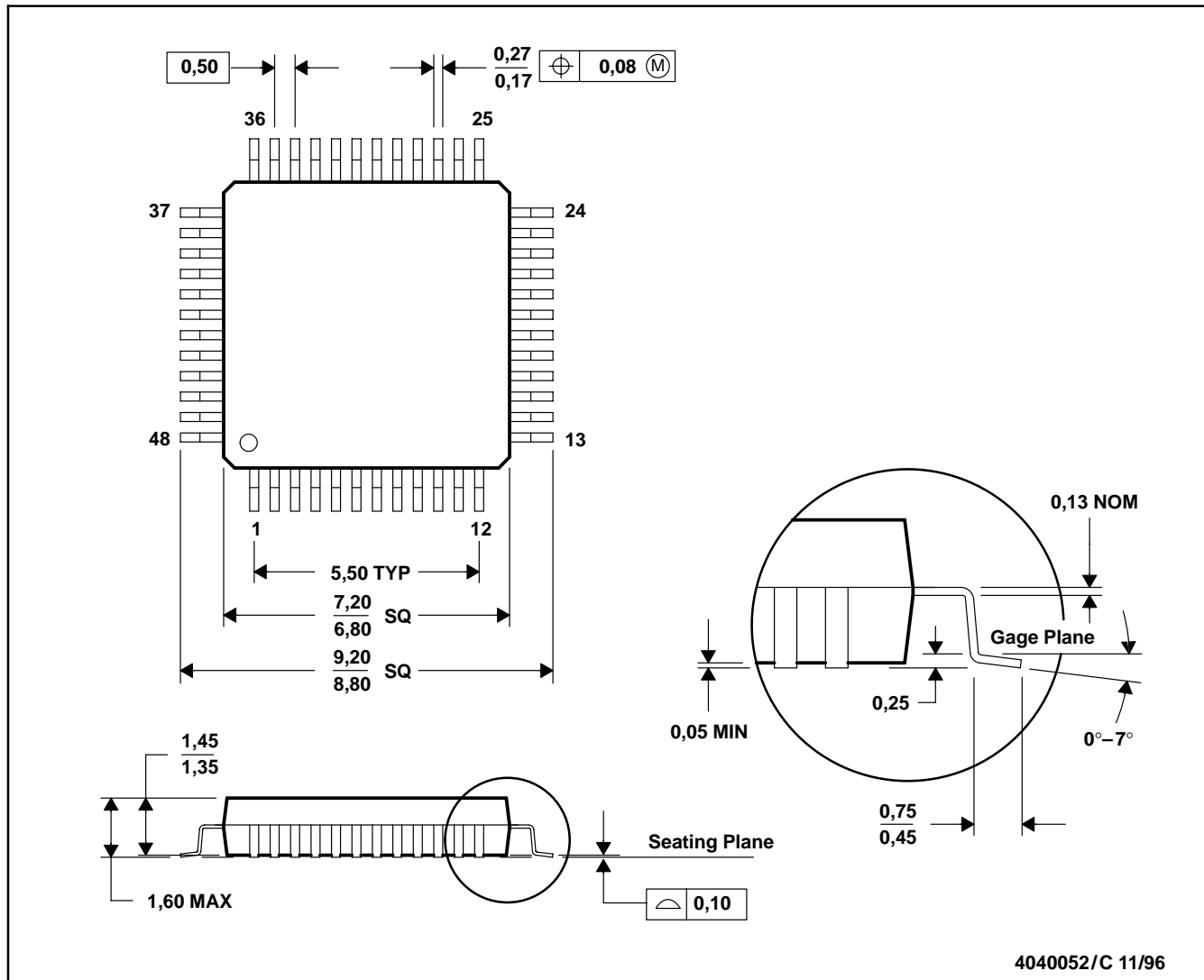

- NOTES: A. All linear dimensions are in millimeters.
 B. This drawing is subject to change without notice.
 C. Falls within JEDEC MS-026
 D. This may also be a thermally enhanced plastic package with leads connected to the die pads.

PACKAGING INFORMATION

Orderable Device	Status ⁽¹⁾	Package Type	Package Drawing	Pins	Package Qty	Eco Plan ⁽²⁾	Lead/Ball Finish	MSL Peak Temp ⁽³⁾
TRF6900APT	ACTIVE	LQFP	PT	48	250	None	CU NIPDAU	Level-2-220C-1 YEAR
TRF6900APTR	ACTIVE	LQFP	PT	48	1000	None	CU NIPDAU	Level-2-220C-1 YEAR

⁽¹⁾ The marketing status values are defined as follows:

ACTIVE: Product device recommended for new designs.

LIFEBUY: TI has announced that the device will be discontinued, and a lifetime-buy period is in effect.

NRND: Not recommended for new designs. Device is in production to support existing customers, but TI does not recommend using this part in a new design.

PREVIEW: Device has been announced but is not in production. Samples may or may not be available.

OBsolete: TI has discontinued the production of the device.

⁽²⁾ Eco Plan - May not be currently available - please check <http://www.ti.com/productcontent> for the latest availability information and additional product content details.

None: Not yet available Lead (Pb-Free).

Pb-Free (RoHS): TI's terms "Lead-Free" or "Pb-Free" mean semiconductor products that are compatible with the current RoHS requirements for all 6 substances, including the requirement that lead not exceed 0.1% by weight in homogeneous materials. Where designed to be soldered at high temperatures, TI Pb-Free products are suitable for use in specified lead-free processes.

Green (RoHS & no Sb/Br): TI defines "Green" to mean "Pb-Free" and in addition, uses package materials that do not contain halogens, including bromine (Br) or antimony (Sb) above 0.1% of total product weight.

⁽³⁾ MSL, Peak Temp. -- The Moisture Sensitivity Level rating according to the JEDEC industry standard classifications, and peak solder temperature.

Important Information and Disclaimer: The information provided on this page represents TI's knowledge and belief as of the date that it is provided. TI bases its knowledge and belief on information provided by third parties, and makes no representation or warranty as to the accuracy of such information. Efforts are underway to better integrate information from third parties. TI has taken and continues to take reasonable steps to provide representative and accurate information but may not have conducted destructive testing or chemical analysis on incoming materials and chemicals. TI and TI suppliers consider certain information to be proprietary, and thus CAS numbers and other limited information may not be available for release.

In no event shall TI's liability arising out of such information exceed the total purchase price of the TI part(s) at issue in this document sold by TI to Customer on an annual basis.

IMPORTANT NOTICE

Texas Instruments Incorporated and its subsidiaries (TI) reserve the right to make corrections, modifications, enhancements, improvements, and other changes to its products and services at any time and to discontinue any product or service without notice. Customers should obtain the latest relevant information before placing orders and should verify that such information is current and complete. All products are sold subject to TI's terms and conditions of sale supplied at the time of order acknowledgment.

TI warrants performance of its hardware products to the specifications applicable at the time of sale in accordance with TI's standard warranty. Testing and other quality control techniques are used to the extent TI deems necessary to support this warranty. Except where mandated by government requirements, testing of all parameters of each product is not necessarily performed.

TI assumes no liability for applications assistance or customer product design. Customers are responsible for their products and applications using TI components. To minimize the risks associated with customer products and applications, customers should provide adequate design and operating safeguards.

TI does not warrant or represent that any license, either express or implied, is granted under any TI patent right, copyright, mask work right, or other TI intellectual property right relating to any combination, machine, or process in which TI products or services are used. Information published by TI regarding third-party products or services does not constitute a license from TI to use such products or services or a warranty or endorsement thereof. Use of such information may require a license from a third party under the patents or other intellectual property of the third party, or a license from TI under the patents or other intellectual property of TI.

Reproduction of information in TI data books or data sheets is permissible only if reproduction is without alteration and is accompanied by all associated warranties, conditions, limitations, and notices. Reproduction of this information with alteration is an unfair and deceptive business practice. TI is not responsible or liable for such altered documentation.

Resale of TI products or services with statements different from or beyond the parameters stated by TI for that product or service voids all express and any implied warranties for the associated TI product or service and is an unfair and deceptive business practice. TI is not responsible or liable for any such statements.

Following are URLs where you can obtain information on other Texas Instruments products and application solutions:

Products		Applications	
Amplifiers	amplifier.ti.com	Audio	www.ti.com/audio
Data Converters	dataconverter.ti.com	Automotive	www.ti.com/automotive
DSP	dsp.ti.com	Broadband	www.ti.com/broadband
Interface	interface.ti.com	Digital Control	www.ti.com/digitalcontrol
Logic	logic.ti.com	Military	www.ti.com/military
Power Mgmt	power.ti.com	Optical Networking	www.ti.com/opticalnetwork
Microcontrollers	microcontroller.ti.com	Security	www.ti.com/security
		Telephony	www.ti.com/telephony
		Video & Imaging	www.ti.com/video
		Wireless	www.ti.com/wireless

Mailing Address: Texas Instruments
Post Office Box 655303 Dallas, Texas 75265