



TS925

RAIL TO RAIL HIGH OUTPUT CURRENT QUAD OPERATIONAL AMPLIFIER

- RAIL TO RAIL INPUT AND OUTPUT
- LOW NOISE : $9\text{nV}/\sqrt{\text{Hz}}$
- LOW DISTORTION
- HIGH OUTPUT CURRENT : **80mA**
(able to drive 32Ω loads)
- HIGH SPEED : **4MHz**, **1.3V/ μs**
- OPERATING FROM **2.7V TO 12V**
- LOW INPUT OFFSET VOLTAGE : **900 μV max.** (TS925A)

- **ADJUSTABLE PHANTOM GROUND ($V_{CC}/2$)**
- **STANDBY MODE**

- ESD INTERNAL PROTECTION : 2kV
- LATCH-UP IMMUNITY
- **MACROMODEL INCLUDED IN THIS SPECIFICATION**

DESCRIPTION

The TS925 is a RAIL TO RAIL quad BiCMOS operational amplifier optimized and fully specified for 3V and 5V operation.

High output current allows low load impedances to be driven. An internal low impedance PHANTOM GROUND eliminates the need for an external reference voltage or biasing arrangement.

The TS925 exhibits a very low noise, low distortion and high output current making this device an excellent choice for high quality, low voltage or battery operated audio/telecom systems.

The device is stable for capacitive loads up to 500pF.

When the STANDBY mode is enabled, the total consumption drops to 6 μA ($V_{CC} = 3\text{V}$).

APPLICATIONS

- Headphone amplifier
- Soundcard amplifier, piezoelectric speaker
- MPEG boards, multimedia systems, ...
- Cordless telephones and portable communication equipment
- Line driver, buffer
- Instrumentation with low noise as key factor

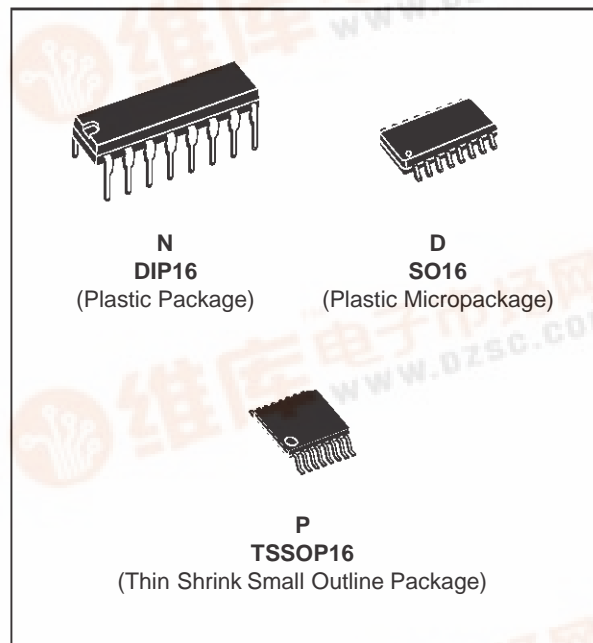

ORDER CODES

Part Number	Temperature Range	Package		
		N	D	P
TS925I	-40, +125°C	•	•	•

PIN CONNECTIONS

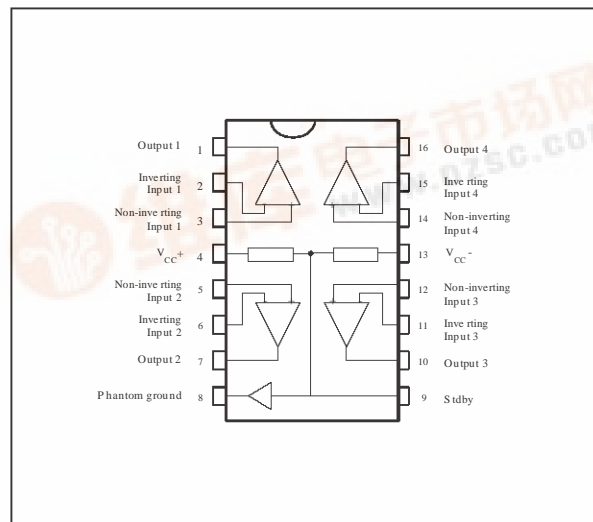

ABSOLUTE MAXIMUM RATINGS

Symbol	Parameter	Value	Unit
V _{CC}	Supply Voltage - (note 1)	14	V
V _{id}	Differential Input Voltage - (note 2)	± 1	V
V _i	Input Voltage - (note 3)	-0.3 to 14	V
T _{oper}	Operating Free Air Temperature Range	-40 to +125	°C
T _j	Maximum Junction Temperature	150	°C
R _{thja}	Thermal Resistance Junction to Ambient	130	°C/W
	Output Short-Circuit Duration	see note 4	

- Notes :**
1. All voltage values, except differential voltage are with respect to network ground terminal.
 2. Differential voltages are the non-inverting input terminal with respect to the inverting input terminal.
 3. The magnitude of input and output voltages must never exceed V_{CC}⁺ +0.3V.
 4. Short-circuits can cause excessive heating. Destructive dissipation can result from simultaneous short-circuit on all amplifiers. Do not short circuit outputs to V_{CC}⁺ when exceeding 8V : this can induce reliability defects.

OPERATING CONDITIONS

Symbol	Parameter	Value	Unit
V _{CC}	Supply Voltage	2.7 to 12	V
V _{icm}	Common Mode Input Voltage Range	V _{CC} -0.2 to V _{CC} +0.2	V

ELECTRICAL CHARACTERISTICS

$V_{CC}^+ = 3V, V_{CC}^- = 0V, T_{amb} = 25^{\circ}C$ (unless otherwise specified)

OPERATIONAL AMPLIFIER

Symbol	Parameter	Test Condition	Min.	Typ.	Max.	Unit
V_{io}	Input Offset Voltage	$T_{min.} < T_{amb.} < T_{max.}$ TS925 TS925A TS925 TS925A			3 0.9 5 1.8	mV
DV_{io}	Input Offset Voltage Drift			2		$\mu V/^{\circ}C$
I_{io}	Input Offset Current	$V_{out} = 1.5V$		1	30	nA
I_{ib}	Input Bias Current	$V_{out} = 1.5V$		15	100	nA
V_{OH}	High Level Output Voltage R_L connected to $V_{CC/2}$	$R_L = 10k$ $R_L = 600\Omega$ $R_L = 32\Omega$	2.90 2.87	2.63		V
V_{OL}	Low Level Output Voltage R_L connected to $V_{CC/2}$	$R_L = 10k$ $R_L = 600\Omega$ $R_L = 32\Omega$		180	50 100	mV
A_{vd}	Large Signal Voltage Gain	$V_{out} = 2V_{pk-pk}$ $R_L = 10k$ $R_L = 600\Omega$ $R_L = 32\Omega$		200 35 16		V/mV
GBP	Gain Bandwidth Product	$R_L = 600\Omega$		4		MHz
CMR	Common Mode Rejection Ratio		60	80		dB
SVR	Supply Voltage Rejection Ratio	$V_{CC} = 2.7V$ to $3.3V$	60	85		dB
I_o	Output Short-circuit Current		50	80		mA
SR	Slew Rate		0.7	1.3		V/ μs
Pm	Phase Margin at Unit Gain	$R_L = 600\Omega, C_L = 100pF$		68		Degrees
GM	Gain Margin	$R_L = 600\Omega, C_L = 100pF$		12		dB
e_n	Equivalent Input Noise Voltage	$f = 1KHz$		9		$\frac{nV}{\sqrt{Hz}}$
THD	Total Harmonic Distortion	$V_{out} = 2V_{pk-pk}, f = 1kHz$ $A_V = 1$ $R_L = 600\Omega$		0.01		%
C_s	Channel Separation			120		dB

GLOBAL CIRCUIT

Symbol	Parameter	Test Condition	Min.	Typ.	Max.	Unit
I_{CC}	Total Supply Current	No load, $V_{out} = V_{CC}/2$		5	7	mA
I_{stby}	Total Supply Current in STANDBY (pin 9 connected to V_{CC})			6		μ A
V_{enstby}	Pin 9 Voltage to enable the STANDBY mode - (note 1)	$T_{min.} \leq T_{amb} \leq T_{max.}$			0.3 0.4	V
V_{distby}	Pin 9 Voltage to disable the STANDBY mode - (note 1)	$T_{min.} \leq T_{amb} \leq T_{max.}$	1.1 1			V

Note 1 : the STANDBY mode is currently enabled when Pin 9 is GROUNDED and disabled when Pin 9 is left OPEN.

PHANTOM GROUND

Symbol	Parameter	Test Condition	Min.	Typ.	Max.	Unit
V_{pg}	Phantom Ground Output Voltage	No Output Current	$V_{CC}/2$ -5%	$V_{CC}/2$	$V_{CC}/2$ +5%	V
I_{pgsc}	Phantom Ground Output Short Circuit Current (sourced)		12	18		mA
Z_{pg}	Phantom Ground Impedance	DC to 20kHz		3		Ω
E_{npg}	Phantom Ground Output Voltage Noise ($f = 1kHz$)	$C_{dec} = 100pF$ $C_{dec} = 1nF$ $C_{dec} = 10nF$ (note 2)		200 40 17		nV/\sqrt{Hz}
I_{pgsk}	Phantom Ground Output Short Circuit Current (sunked)		12	18		mA

Note 2 : C_{dec} is the decoupling capacitor on Pin 9.

ELECTRICAL CHARACTERISTICS

$V_{CC}^+ = 5V, V_{CC}^- = 0V, T_{amb} = 25^{\circ}C$ (unless otherwise specified)

OPERATIONAL AMPLIFIER

Symbol	Parameter	Test Condition	Min.	Typ.	Max.	Unit
V_{io}	Input Offset Voltage	$T_{min.} < T_{amb.} < T_{max.}$ TS925 TS925A TS925 TS925A			3 0.9 5 1.8	mV
DV_{io}	Input Offset Voltage Drift			2		$\mu V/^{\circ}C$
I_{io}	Input Offset Current	$V_{out} = 2.5V$		1	30	nA
I_{ib}	Input Bias Current	$V_{out} = 2.5V$		15	100	nA
V_{OH}	High Level Output Voltage R_L connected to $V_{CC}/2$	$R_L = 10k$ $R_L = 600\Omega$ $R_L = 32\Omega$	4.9 4.85	4.4		V
V_{OL}	Low Level Output Voltage R_L connected to $V_{CC}/2$	$R_L = 10k$ $R_L = 600\Omega$ $R_L = 32\Omega$		300	50 120	mV
A_{vd}	Large Signal Voltage Gain	$V_{out} = 4V_{pk-pk}$ $R_L = 10k$ $R_L = 600\Omega$ $V_{out} = 2V_{pk-pk}, R_L = 32\Omega$		200 40 17		V/mV
GBP	Gain Bandwidth Product	$R_L = 600\Omega$		4		MHz
CMR	Common Mode Rejection Ratio		60	80		dB
SVR	Supply Voltage Rejection Ratio	$V_{CC} = 3V$ to $5V$	60	85		dB
I_o	Output Short-circuit Current		50	80		mA
SR	Slew Rate		0.7	1.3		V/ μs
Pm	Phase Margin at Unit Gain	$R_L = 600\Omega, C_L = 100pF$		68		Degrees
GM	Gain Margin	$R_L = 600\Omega, C_L = 100pF$		12		dB
e_n	Equivalent Input Noise Voltage	$f = 1KHz$		9		$\frac{nV}{\sqrt{Hz}}$
THD	Total Harmonic Distortion	$V_{out} = 3V_{pk-pk}, f = 1kHz$ $A_v = 1$ $R_L = 600\Omega$		0.01		%
C_s	Channel Separation			120		dB

GLOBAL CIRCUIT

Symbol	Parameter	Test Condition	Min.	Typ.	Max.	Unit
I_{CC}	Total Supply Current	No load, $V_{out} = V_{CC}/2$		6	8	mA
I_{stby}	Total Supply Current in STANDBY (pin 9 connected to V_{CC})			10		μ A
V_{enstby}	Pin 9 Voltage to enable the STANDBY mode - (note 1)	$T_{min.} \leq T_{amb} \leq T_{max.}$			0.3 0.4	V
V_{distby}	Pin 9 Voltage to disable the STANDBY mode - (note 1)	$T_{min.} \leq T_{amb} \leq T_{max.}$	1.1 1			V

Note 1 : the STANDBY mode is currently enabled when Pin 9 is GROUNDED and disabled when Pin 9 is left OPEN.

PHANTOM GROUND

Symbol	Parameter	Test Condition	Min.	Typ.	Max.	Unit
V_{pg}	Phantom Ground Output Voltage	No Output Current	$V_{CC}/2$ -5%	$V_{CC}/2$	$V_{CC}/2$ +5%	V
I_{pgsc}	Phantom Ground Output Short Circuit Current (sourced)		12	18		mA
Z_{pg}	Phantom Ground Impedance	DC to 20kHz		3		Ω
E_{npg}	Phantom Ground Output Voltage Noise ($f = 1$ kHz)	$C_{dec} = 100$ pF $C_{dec} = 1$ nF $C_{dec} = 10$ nF (note 2)		200 40 17		nV/\sqrt{Hz}
I_{pgsk}	Phantom Ground Output Short Circuit Current (sunked)		12	18		mA

Note 2 : C_{dec} is the decoupling capacitor on Pin 9.

INPUT OFFSET VOLTAGE DISTRIBUTION

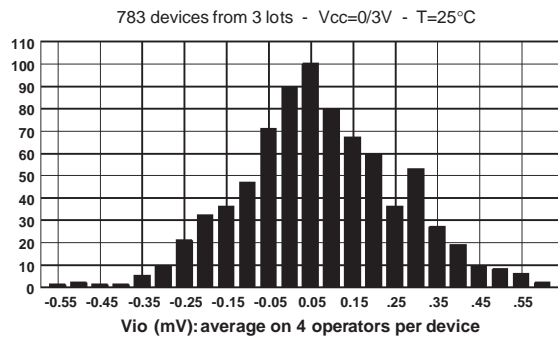

TOTAL SUPPLY CURRENT vs SUPPLY VOLTAGE WITH NO LOAD

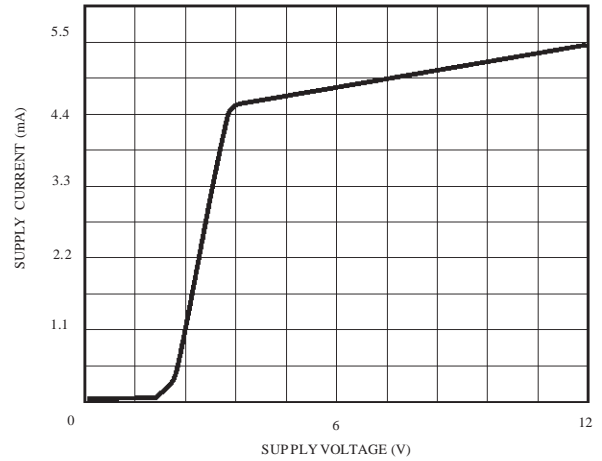

SUPPLY CURRENT/AMPLIFIER vs TEMPERATURE

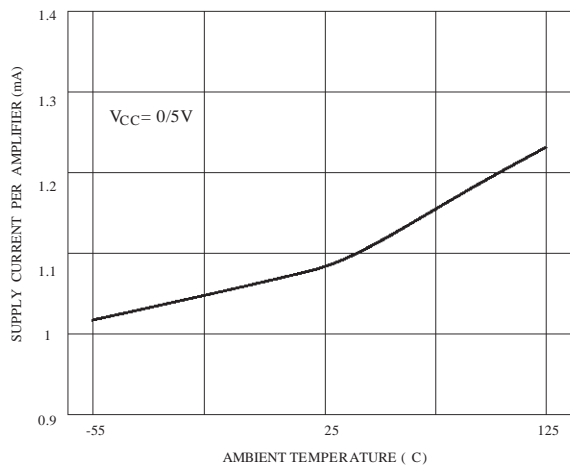

OUTPUT SHORT CIRCUIT CURRENT vs OUTPUT VOLTAGE

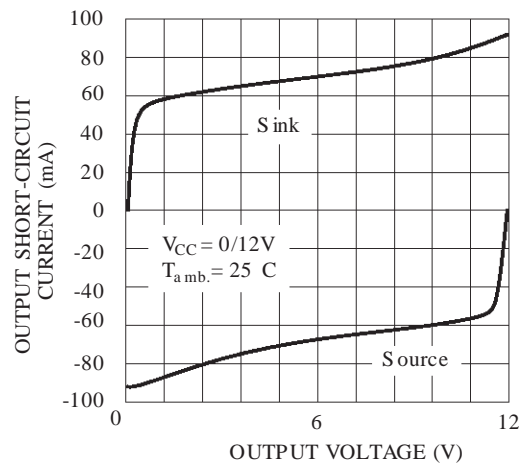

OUTPUT SHORT CIRCUIT CURRENT vs OUTPUT VOLTAGE

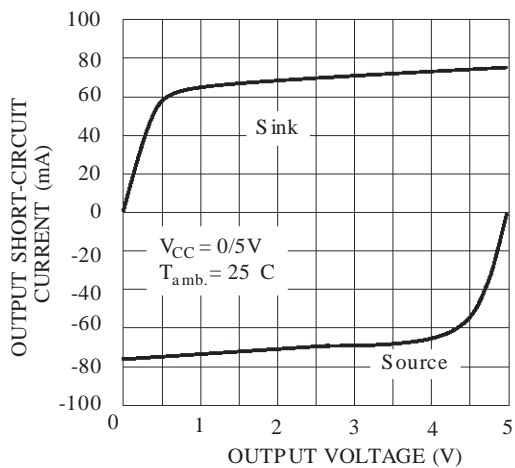

OUTPUT SHORT CIRCUIT CURRENT vs OUTPUT VOLTAGE

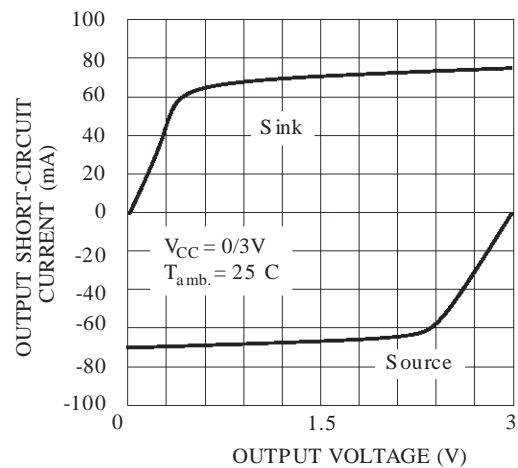

OUTPUT SHORT CIRCUIT CURRENT vs TEMPERATURE

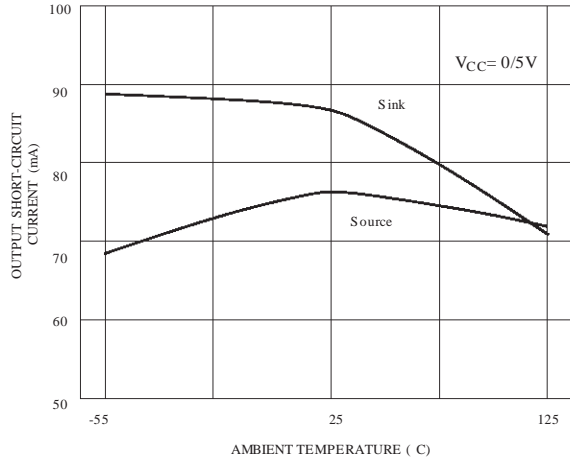

VOLTAGE GAIN AND PHASE vs FREQUENCY

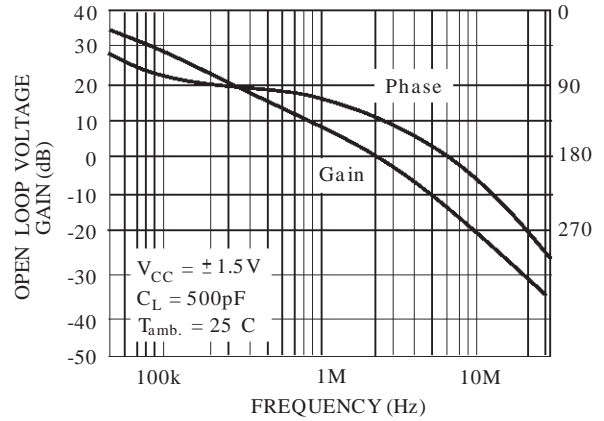

DISTORION + NOISE vs FREQUENCY

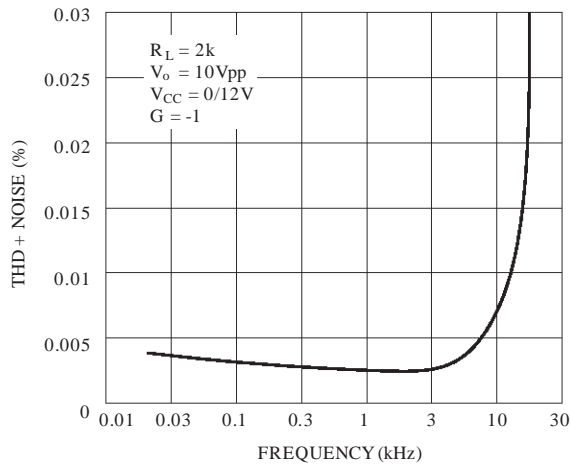

THD + NOISE vs FREQUENCY

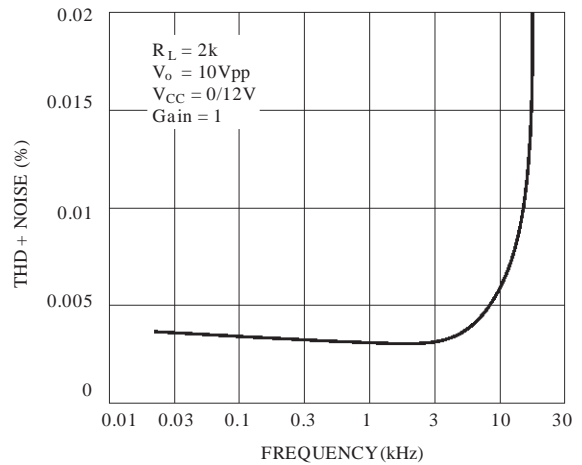

THD + NOISE vs FREQUENCY

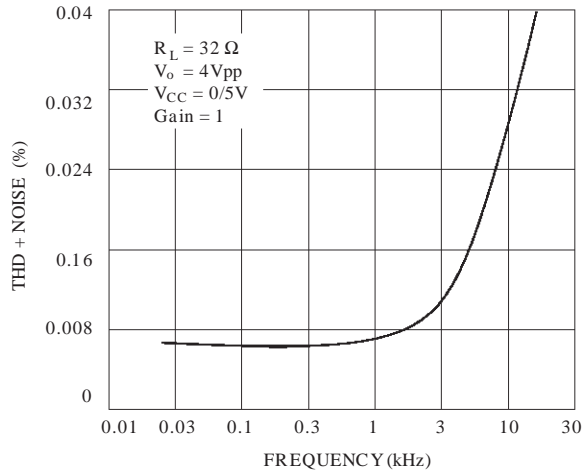

THD + NOISE vs FREQUENCY

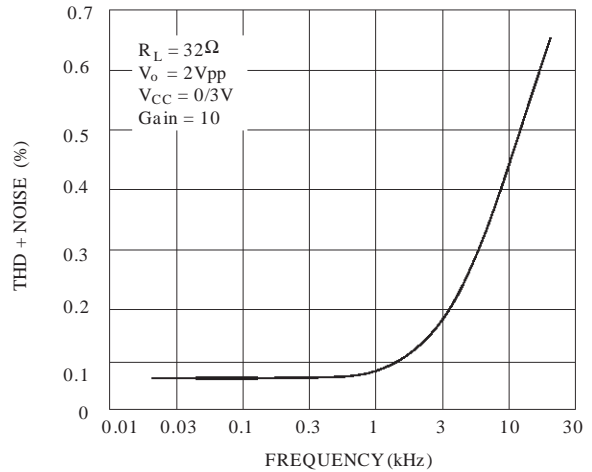

EQUIVALENT INPUT NOISE vs VERSUS FREQUENCY

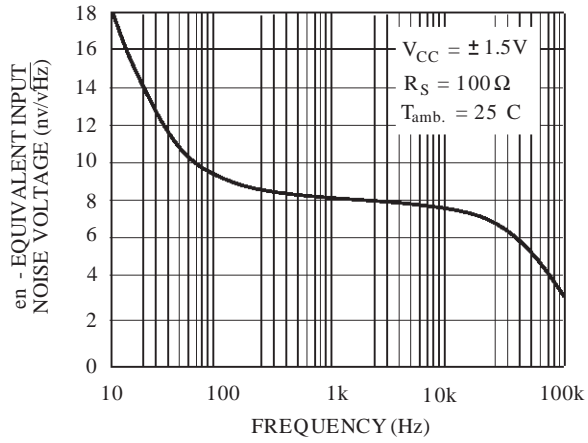

TOTAL SUPPLY CURRENT vs STANDBY INPUT VOLTAGE

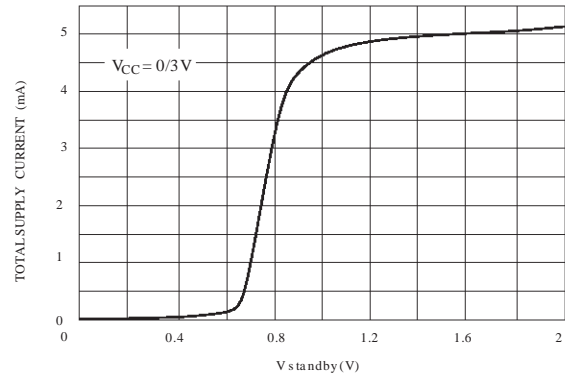

PHANTOM GROUND SHORT CIRCUIT OUTPUT CURRENT vs PHANTOM GROUND OUTPUT VOLTAGE

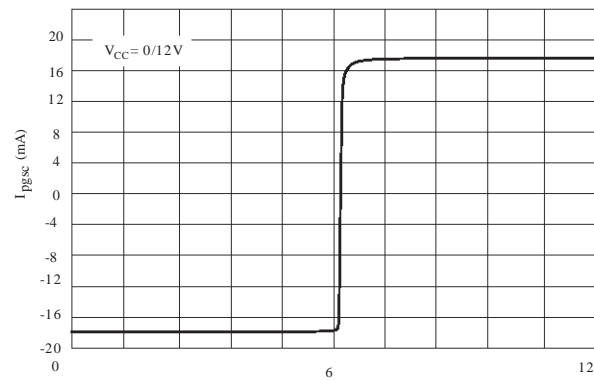

PREAMPLIFIER AND SPEAKER DRIVER USING TS925

by F. MARICOURT

The TS925 is an input/output rail to rail quad BiCMOS operational amplifier. It is able to operate with low supply voltages (2.7V) and to drive low output loads such as 32Ω.

As an illustration of these features, the following technical note highlights many of the advantages of the device in a global audio application.

APPLICATION CIRCUIT

Figure 1 shows two operators (A1, A4) used in a preamplifier configuration, and the two others in a push-pull configuration driving a headset. The phantom ground is used as a common reference level ($V_{CC/2}$).

The power supply is delivered from two LR6 batteries (2x1.5V nominal).

Preamplifier : the operators A1 and A4 are wired with a non inverting gain of respectively :

- A1# ($R4/(R3+R17)$)
- A4# $R6/R5$

With the following values chosen :

- $R4=22k\Omega$ - $R3=50\Omega$ - $R17=1.2k\Omega$
- $R6=47k\Omega$ - $R5=1.2k\Omega$,

the gain of the preamplifier chain is thus 58dB.

Alternatively, the gain of A1 can be adjusted by choosing a JFET transistor Q1 instead of R17.

This JFET voltage controlled resistor arrangement forms an automatic level control (ALC) circuit, useful in many MIC preamplifier applications. The mean rectified peak level of the output signal envelope is used to control the preamplifier gain.

Figure 1 : Electrical Schematic

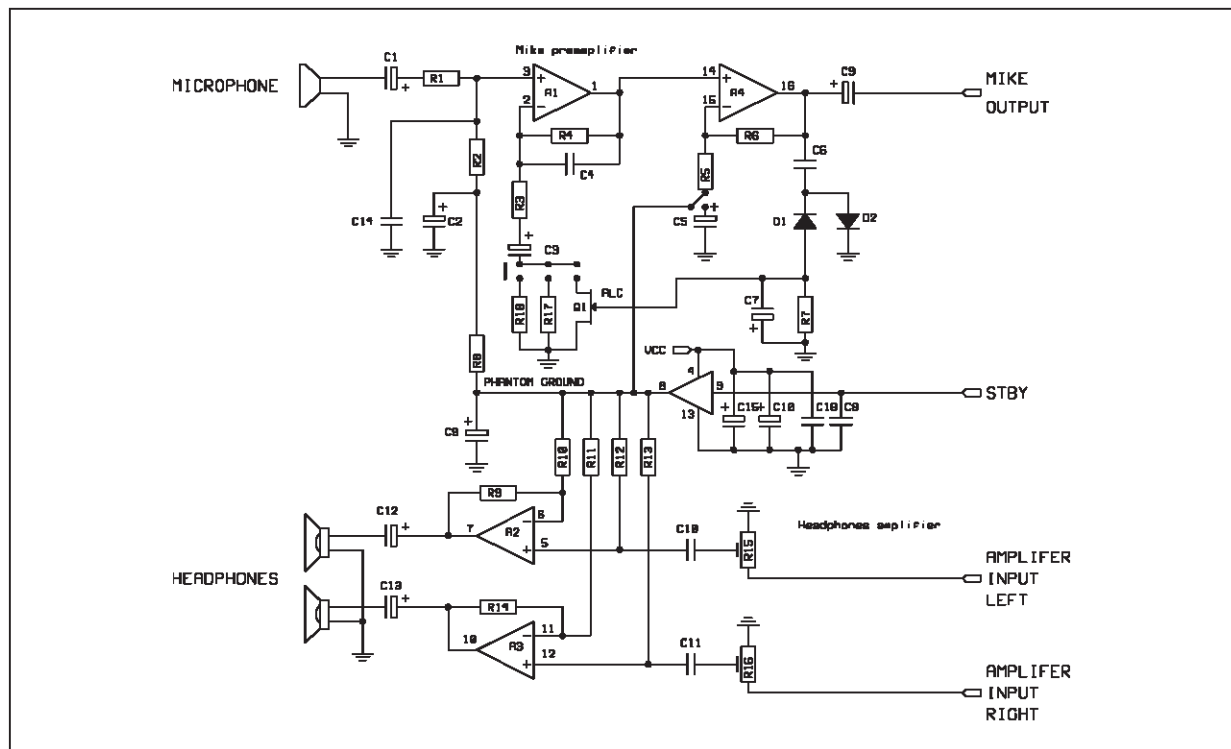

Figure 2 : Frequency Response of the Global Preamplifier Chain

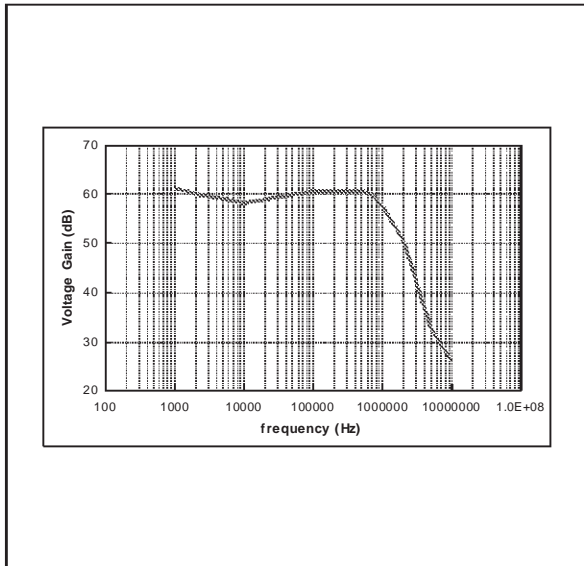
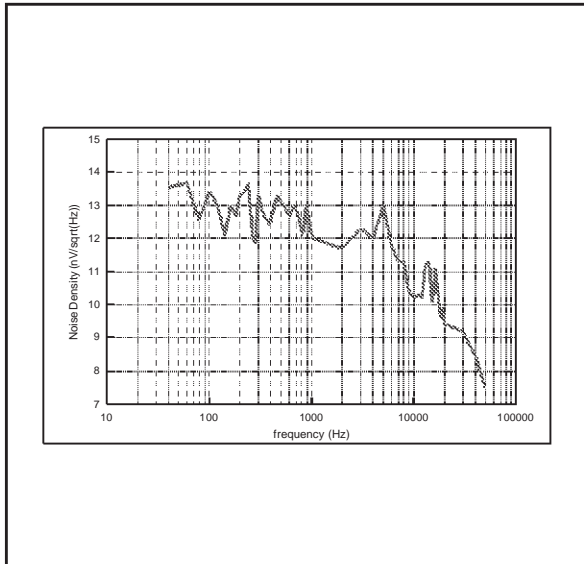

Figure 3 : Voltage Noise Density versus Frequency at Preamplifier Output



Headphone amplifier : the operators A2 and A3 are organized in a push-pull configuration with a gain of 5. The stereo inputs can be connected to a CD-player and the TS925 drives directly the headphone speakers. This configuration shows the ability of the circuit to drive 32Ω load with a maximum output swing and a high fidelity for reproducing sound and music.

Figure 4 shows the available signal swing at the headset outputs : two other rail to rail competitor parts are employed in the same circuit for comparison (note the much reduced clipping level and crossover distortion)

Figure 4 : Maximum Voltage Swing at Headphone Outputs ($R_L = 32\Omega$)

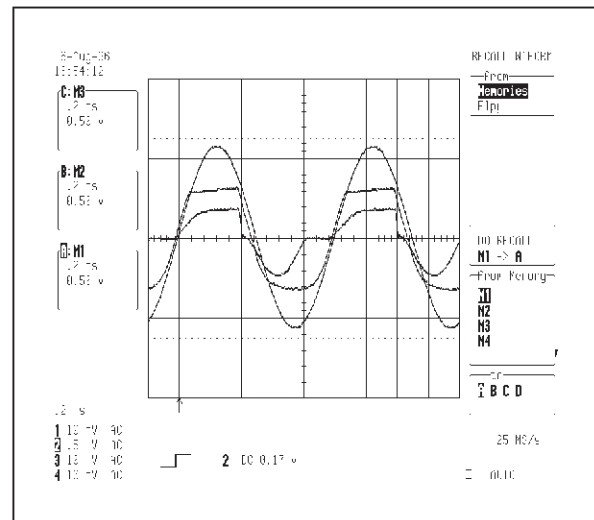
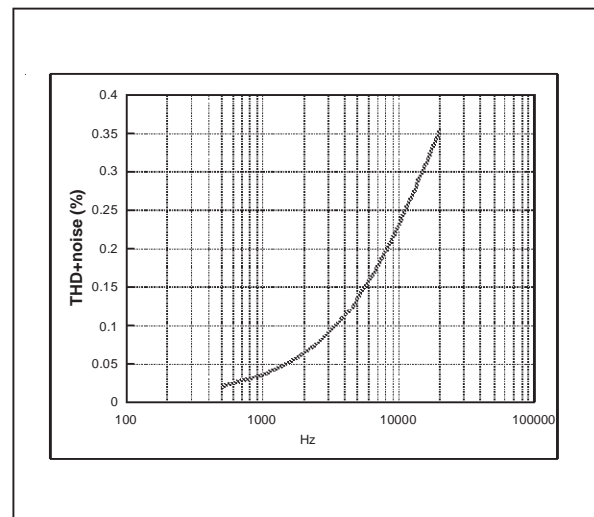

Figure 5 : THD+noise versus Frequency (headphone outputs)



TS925

MACROMODEL

- RAIL TO RAIL INPUT AND OUTPUT
- LOW NOISE : $9nV\sqrt{Hz}$
- LOW DISTORTION
- HIGH OUTPUT CURRENT : **50mA min.**
(able to drive 32Ω loads)
- HIGH SPEED : **4MHz, 1.3V/ μ s**
- OPERATING FROM **2.7V TO 12V**

** Standard Linear Ics Macromodels, 1996.

** CONNECTIONS :

- * 1 INVERTING INPUT
- * 2 NON-INVERTING INPUT
- * 3 OUTPUT
- * 4 POSITIVE POWER SUPPLY
- * 5 NEGATIVE POWER SUPPLY

.SUBCKT TS925 1 3 2 4 5 (analog)

.MODEL MDTH D IS=1E-8 KF=2.664234E-16
CJO=10F

* INPUT STAGE

CIP 2 5 1.000000E-12

CIN 1 5 1.000000E-12

EIP 10 5 2 5 1

EIN 16 5 1 5 1

RIP 10 11 8.125000E+00

RIN 15 16 8.125000E+00

RIS 11 15 2.238465E+02

DIP 11 12 MDTH 400E-12

DIN 15 14 MDTH 400E-12

VOFP 12 13 DC 153.5u

VOFN 13 14 DC 0

IPOL 13 5 3.200000E-05

CPS 11 15 1e-9

DINN 17 13 MDTH 400E-12

VIN 17 5 -0.100000e+00

DINR 15 18 MDTH 400E-12

VIP 4 18 0.400000E+00

FCP 4 5 VOFP 1.865000E+02

FCN 5 4 VOFN 1.865000E+02

FIBP 2 5 VOFP 6.250000E-03

FIBN 5 1 VOFN 6.250000E-03

* GM1 STAGE *****

FGM1P 119 5 VOFP 1.1

FGM1N 119 5 VOFN 1.1

RAP 119 4 2.6E+06

RAN 119 5 2.6E+06

* GM2 STAGE *****

G2P 19 5 119 5 1.92E-02

G2N 19 5 119 4 1.92E-02

R2P 19 4 1E+07

R2N 19 5 1E+07

VINT1 500 0 5

GCONVP 500 501 119 4 19.38 !envoi ds VP,

I(VP)=(V119-V4)/2/Ut VP 501 0 0

GCONVN 500 502 119 5 19.38 !envoi ds VN,

I(VN)=(V119-V5)/2/Ut VN 502 0 0

***** orientation isink isource *****

VINT2 503 0 5

FCOPY 503 504 VOUT 1

DCOPYP 504 505 MDTH 400E-9

VCOPYP 505 0 0

DCOPYN 506 504 MDTH 400E-9

VCOPYN 0 506 0

F2PP 19 5 poly(2) VCOPYP VP 0 0 0 0 0.5 !multiplie
I(vout)*I(VP)=Iout*(V119-V4)/2/Ut

F2PN 19 5 poly(2) VCOPYP VN 0 0 0 0 0.5
!multiplie I(vout)*I(VN)=Iout*(V119-V5)/2/Ut

F2NP 19 5 poly(2) VCOPYN VP 0 0 0 0 1.75
!multiplie I(vout)*I(VP)=Iout*(V119-V4)/2/Ut

F2NN 19 5 poly(2) VCOPYN VN 0 0 0 0 1.75
!multiplie I(vout)*I(VN)=Iout*(V119-V5)/2/Ut

* COMPENSATION *****

CC 19 119 25p

* OUTPUT*****

DOPM 19 22 MDTH 400E-12

DONM 21 19 MDTH 400E-12

HOPM 22 28 VOUT 6.250000E+02

VIPM 28 4 5.000000E+01

HONM 21 27 VOUT 6.250000E+02

VINM 5 27 5.000000E+01

VOUT 3 23 0

ROUT 23 19 6

COUT 3 5 1.300000E-10

DOP 19 25 MDTH 400E-12

VOP 4 25 1.052

DON 24 19 MDTH 400E-12

VON 24 5 1.052

.ENDS

ELECTRICAL CHARACTERISTICS

$V_{CC}^+ = 3V$, $V_{CC}^- = 0V$, R_L, C_L connected to $V_{CC}/2$, $T_{amb} = 25^\circ C$
(unless otherwise specified)

Symbol	Conditions	Value	Unit
V_{io}		0	mV
A_{vd}	$R_L = 10k\Omega$	200	V/mV
I_{CC}	No load, per operator	1.2	mA
V_{icm}		-0.2 to 3.2	V
V_{OH}	$R_L = 10k\Omega$	2.95	V
V_{OL}	$R_L = 10k\Omega$	25	mV
I_{sink}	$V_O = 3V$	80	mA
I_{source}	$V_O = 0V$	80	mA
GBP	$R_L = 600\Omega$	4	MHz
SR	$R_L = 10k\Omega$, $C_L = 100pF$	1.3	V/ μs
$\varnothing m$	$R_L = 600\Omega$	68	Degrees

TS925

PACKAGE MECHANICAL DATA

16 PINS - PLASTIC DIP

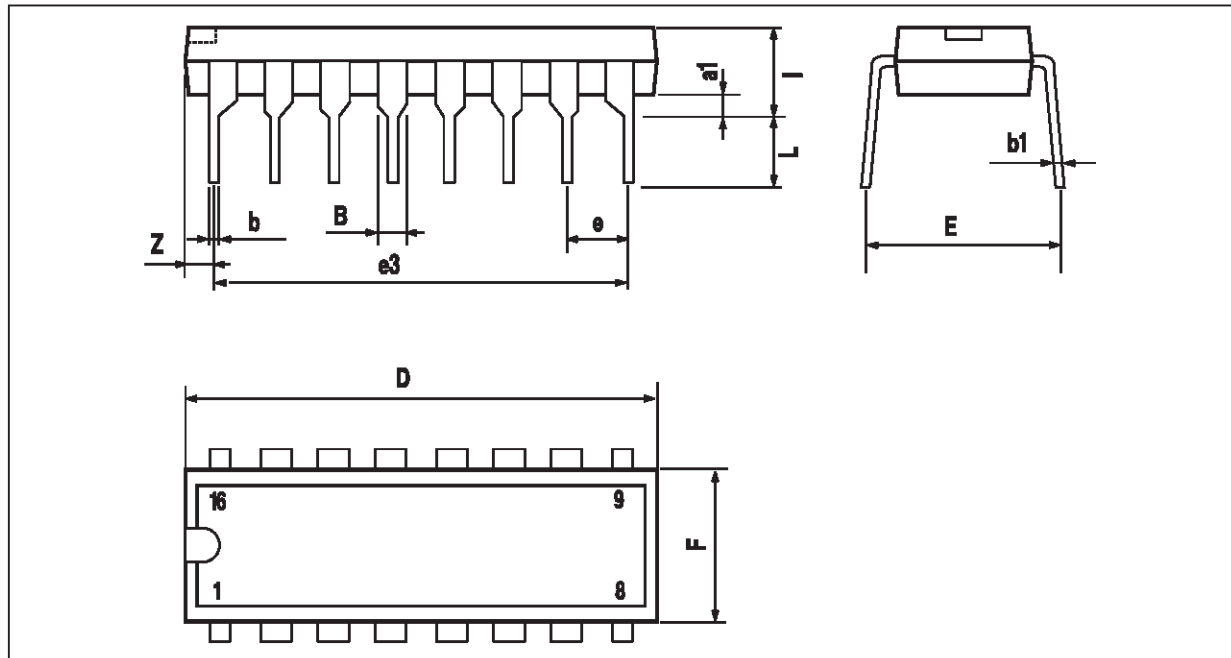

Dimensions	Millimeters			Inches		
	Min.	Typ.	Max.	Min.	Typ.	Max.
a1	0.51			0.020		
B	0.77		1.65	0.030		0.065
b		0.5			0.020	
b1		0.25			0.010	
D			20			0.787
E		8.5			0.335	
e		2.54			0.100	
e3		17.78			0.700	
F			7.1			0.280
i			5.1			0.201
L		3.3			0.130	
Z			1.27			0.050

PACKAGE MECHANICAL DATA
 16 PINS - PLASTIC MICROPACKAGE (SO)

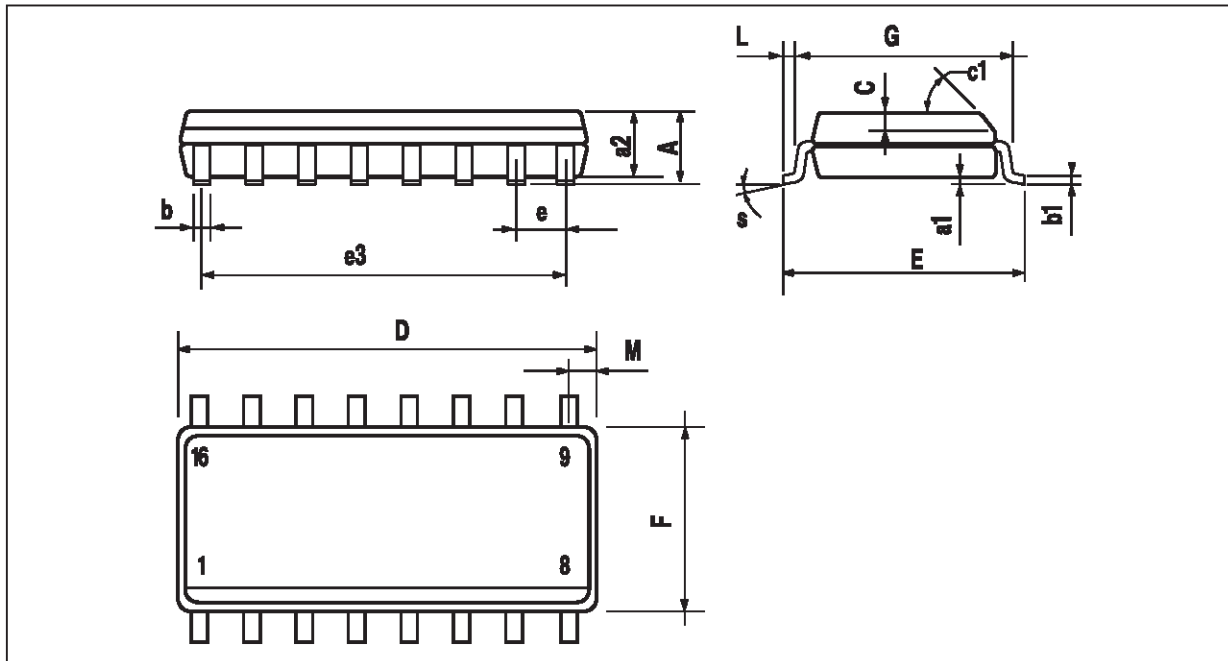

Dimensions	Millimeters			Inches		
	Min.	Typ.	Max.	Min.	Typ.	Max.
A			1.75			0.069
a1	0.1		0.2	0.004		0.008
a2			1.6			0.063
b	0.35		0.46	0.014		0.018
b1	0.19		0.25	0.007		0.010
C		0.5			0.020	
c1	45° (typ.)					
D	9.8		10	0.386		0.394
E	5.8		6.2	0.228		0.244
e		1.27			0.050	
e3		8.89			0.350	
F	3.8		4.0	0.150		0.157
G	4.6		5.3	0.181		0.209
L	0.5		1.27	0.020		0.050
M			0.62			0.024

PACKAGE MECHANICAL DATA
 16 PINS - THIN SHRINK SMALL OUTLINE PACKAGE

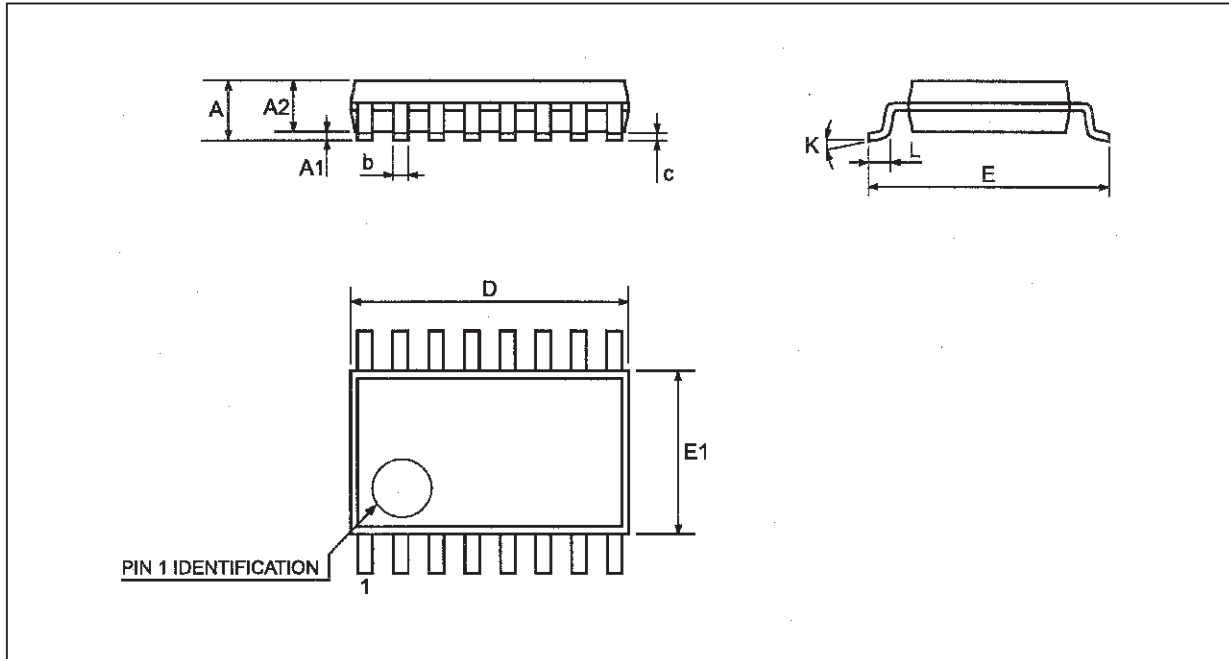

Dim.	Millimeters			Inches		
	Min.	Typ.	Max.	Min.	Typ.	Max.
A			1.20			0.05
A1	0.05		0.15	0.01		0.006
A2	0.80	1.00	1.05	0.031	0.039	0.041
b	0.15		0.30	0.005		0.15
c	0.1		0.20	0.003		0.012
D	4.90	5.00	5.10	0.192	0.196	0.20
E		6.40			0.252	
E1	4.30	4.40	4.50	0.169	0.173	0.177
e		0.65			0.025	
k	0°		8°	0°		8°
l	0.50	0.60	0.75	0.09	0.0236	0.030

Information furnished is believed to be accurate and reliable. However, STMicroelectronics assumes no responsibility for the consequences of use of such information nor for any infringement of patents or other rights of third parties which may result from its use. No license is granted by implication or otherwise under any patent or patent rights of STMicroelectronics. Specifications mentioned in this publication are subject to change without notice. This publication supersedes and replaces all information previously supplied. STMicroelectronics products are not authorized for use as critical components in life support devices or systems without express written approval of STMicroelectronics.

© The ST logo is a trademark of STMicroelectronics

© 1999 STMicroelectronics – Printed in Italy – All Rights Reserved

STMicroelectronics GROUP OF COMPANIES

Australia - Brazil - Canada - China - France - Germany - Italy - Japan - Korea - Malaysia - Malta - Mexico - Morocco
 The Netherlands - Singapore - Spain - Sweden - Switzerland - Taiwan - Thailand - United Kingdom - U.S.A.

© <http://www.st.com>