

UHF AM/FM Transmitter

Description

The U2740B-B is an one-chip multi-purpose UHF ASK/FSK transmitter IC designed for various applications within a wide frequency range. When a Chip-Select (CS) signal is supplied, the IC starts operation (Power-up, XTO, VCO, PD) and the VCO is then locked to $128 \times f(XTO)$. The locked status is indicated at the Lock-Detect (LD) output.

The digital data is supplied to either an AM- or FM-input pin, the output power being set via the AM-input pin. A differential output enables simple applications with loop antennas. An output driver (XTO_out) can be used for clocking the microcontroller.

Features

- One-chip solution with few external components
- Wide frequency range (200 to 500 MHz)
- Single voltage supply (2.2 to 5.5 V) with power-down feature
- Adjustable output power with differential output for loop antenna
- PLL lock-detect signal
- XTO output for μC clock
- ESD protection according to MIL-STD. 883 (except Pins 1, 2, 13 and 14)
- Low standby current $<0.25 \mu A$ for $V_S = 3 V$
- Single lithium-cell operation

Applications

- Keyless entry (automotive, domestic,...)
- Alarm systems
- Remote control
- Communication systems

Ordering Information

Extended Type Number	Package	Remarks
U2740B-BFP	SO16	

System Block Diagram

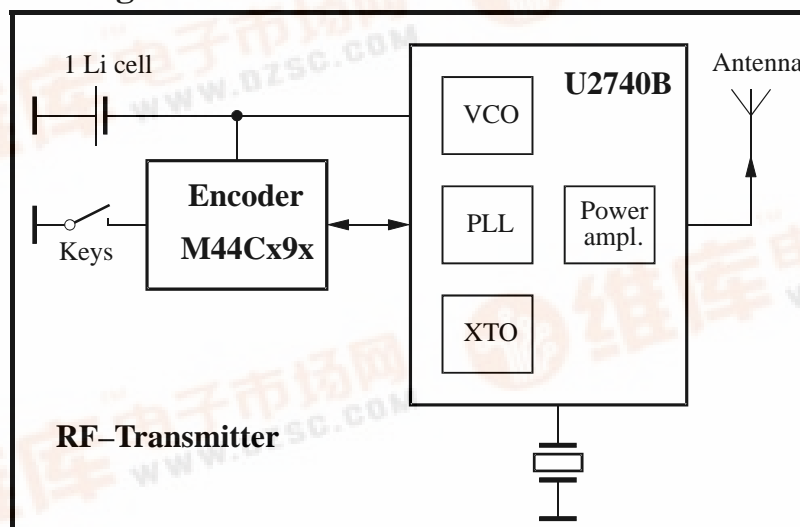

13350

Figure 1. System block diagram

Pin Description

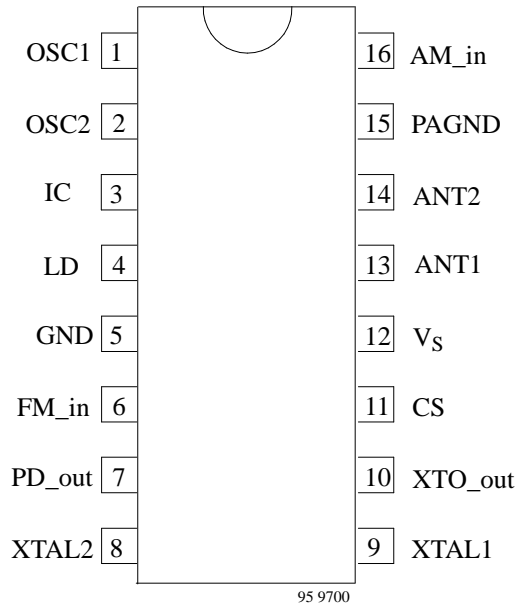

Pin	Symbol	Function
1	OSC1	VCO tank
2	OSC2	VCO tank
3	IC	Internally connected
4	LD	Lock-detect (open collector)
5	GND	Ground
6	FM_in	FM modulation input
7	PD_out	Phase detector output
8	XTAL2	FM modulation capacitor
9	XTAL1	XTAL
10	XTO_out	XTO output (open collector)
11	CS	Chip-select (power-up)
12	V _S	Supply voltage
13	ANT1	Differential output 1
14	ANT2	Differential output 2
15	PAGND	Power amplifier ground
16	AM_in	AM modulation input

Figure 2. Pinning

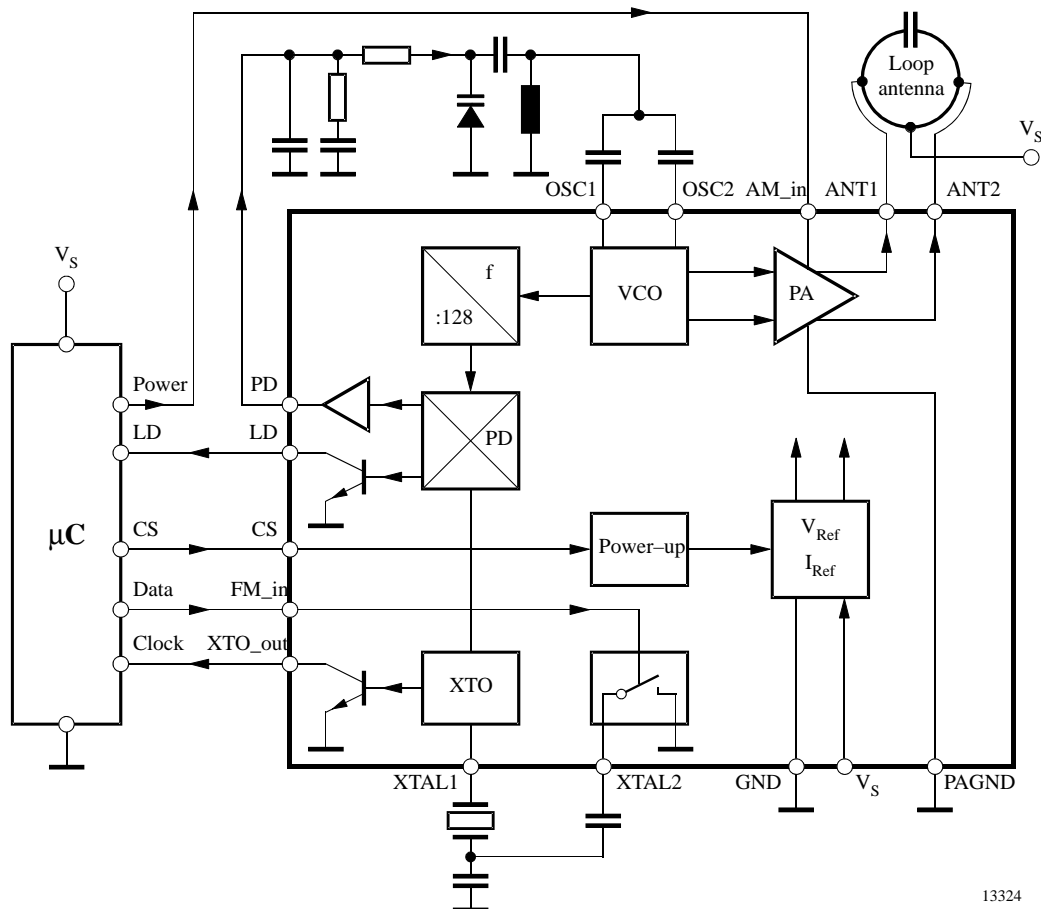

Figure 3. Block diagram

Circuit Description

The transmitter PLL U2740B contains the complete RF part for a radio control system. The IC consists of a VCO, a complete PLL circuit, a crystal oscillator, a power amplifier and a power-up module. An integrated switch can be used to change the load capacitance of the crystal.

VCO

The VCO is a voltage-controlled current source. The frequency is determined by the external LC-tank. The frequency is changed via a Varicap diode.

PLL

The complete PLL consists of a prescaler, a digital phase/frequency detector (PFD) with charge-pump output. The output frequency is locked to 128 times the frequency of the XTO. The PFD, however, operates at a frequency four times lower than that of the XTO. A lock-detect output indicates that the PLL is locked.

Crystal Oscillator (XTO)

It is a single-pin crystal oscillator, operating at the series resonant frequency of the crystal. Depending on the type of crystal used, this oscillator takes 3 to 20 ms until settling after setting CS to V_S . The integrated switch can be used to change the load capacitance. Thus, the output frequency is FSK modulated.

Power Amplifier (PA)

As figure 4 shows, the differential PA switches its output current between the two power output pins (ANT1, ANT2). The output current is seven times the current flowing into the AM_in Pin. The achievable output power is about 1.5 mW.

Power-up

When CS = 0 V, the circuit is in standby mode with a power-down supply current of type. $I_{S,off} = 0.1 \mu A$. With CS = V_S , the circuit is in power-up mode.

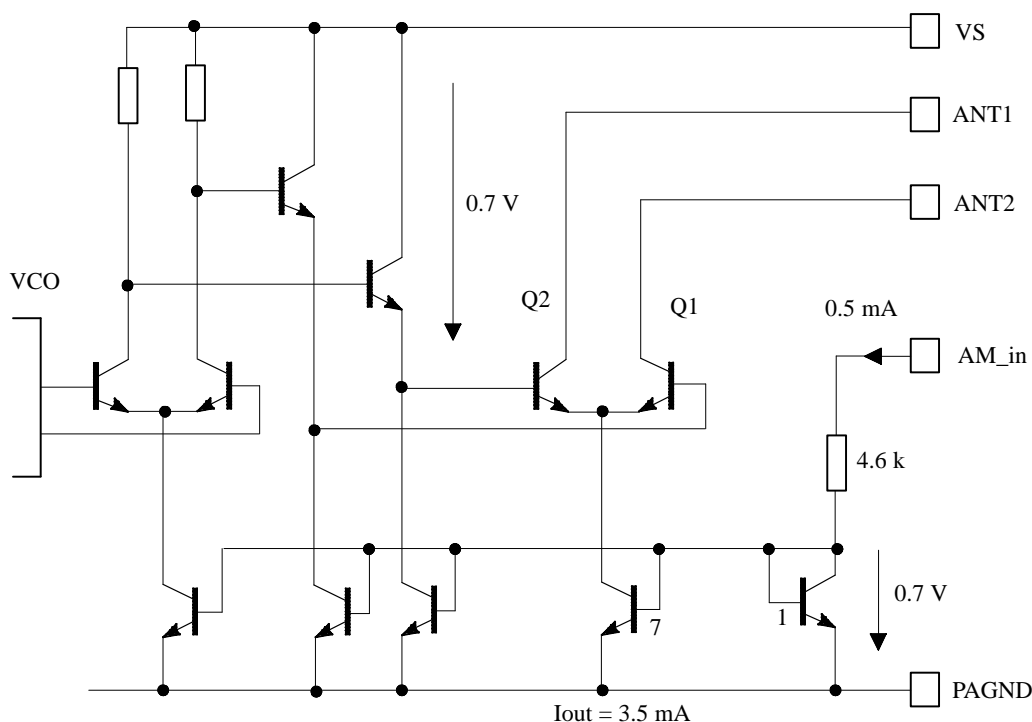

Figure 4. Power output stage of U2740B

Absolute Maximum Ratings

Parameters	Symbol	Min.	Max.	Unit
Supply voltage Pin 12	V_S	-0.3	5.5	V
Voltage at Pins 13 and 14		-0.3	10	V
Input current AM_in Pin 16			0.75	mA
Output current lock detect Pin 4			1.5	mA
Output current XTO_out Pin 10			1.5	mA
Junction temperature	T_j		125	°C
Storage temperature	T_{stg}	-55	125	°C

Thermal Resistance

Parameters	Symbol	Min.	Typ.	Max.	Unit
Junction ambient SO16	R_{thJA}			120	K/W

Operating Range

All voltages are referred to GND (Pin 5) and PAGND (Pin 15), $T_{amb} = -40$ to $+85^\circ\text{C}$, unless otherwise specified

Parameters	Symbol	Min.	Typ.	Max.	Unit
Supply voltage Pin 12	V_S	2.4	3.0	5.5	V
Supply voltage, $T_{amb} = -20$ to $+85^\circ\text{C}$	V_S	2.2	3.0	5.5	V
Minimum supply voltage, $T_{amb} = 25^\circ\text{C}$			1.8		V
Minimum supply voltage, $T_{amb} = -20^\circ\text{C}$			2.0		V
Carrier frequency		200		500	MHz

Electrical Characteristics DC

All voltages referred to GND (Pin 5), $V_S = 2.4$ to 5.5 V, $T_{amb} = -40$ to $+85^\circ\text{C}$, unless otherwise specified

Parameters	Test Conditions / Pins	Symbol	Min.	Typ.	Max.	Unit
Supply current (power-down)	$V_{11} = 0, I_{16} = 0, V_S = 3$ V Pin 12	$I_{S, OFF}$		0.05	0.25	μA
	$V_{11} = 0, I_{16} = 0, V_S = 5.5$ V Pin 12			0.1	0.5	μA
Supply current (power-up, transmit space)	$V_{16} = 0$ V, $V_{11} = V_S$	$I_{S, ON}$		5.0	8.0	mA
	$V_{16} = 0$ V, $V_{11} = 3$ V, $V_S = 3$ V, $T_{amb} = 25^\circ\text{C}$, Pin 12	$I_{S, ON}$	4.5	5.0	6.5	mA
	$V_{16} = 0$ V, $V_{11} = 5.5$ V, $V_S = 5.5$ V, $T_{amb} = 25^\circ\text{C}$, Pin 12	$I_{S, ON}$	4.5	5.8	7.2	mA
Temperature coefficient of supply current ¹⁾	TKI			0.18		%/K
Supply current (power-up, transmit mark)	$V_{16} = 3$ V, $V_{11} = 3$ V, $V_S = 3$ V, $T_{amb} = 25^\circ\text{C}$, Pin 12		8	11	13.5	mA
Power-down voltage	$V_{16} = 0$ V Pin 11	$V_{11, OFF}$			0.4	V
Power-up voltage	$V_{16} = 0$ V Pin 11	$V_{11, ON}$	1.0			V
Power-up current	$V_{11} = 3$ V Pin 11	$I_{11, ON}$		40	65	μA
	$V_{11} = 5.5$ V Pin 11			110	150	
Input current FM_in	$V_6 = 3$ V Pin 6	I_6		16	25	μA
Output current Lock-detect	Pin 4	I_4			1	
Output current XTO_out	Pin 10	I_{10}			1	mA
Input current AM_in ²⁾	R16 = 0 connected to $V_S = 3$ V, Pin 16 $T_{amb} = 25^\circ\text{C}$ $T_{amb} = 85^\circ\text{C}$	I_{16}	0.40	0.50	0.60	mA
			0.44	0.55	0.65	mA

Notes:

- 1) There are circuit parts with increasing supply current over temperature. The resulting supply current is $I_S(T_{amb}) = I_{SDN} (1 + (T_{amb} - 25^\circ\text{C}) \times \text{TKI})$
- 2) This depends on the value of resistor R16 connected to V_S . If the supply voltage is 2.0 to 3.5 V, Pin 16 can be directly connected to V_S . For $V_S = 5$ V, R16 should be 3.9 k Ω .

Electrical Characteristics AC

All voltages referred to GND (Pin 5), $V_S = 2.2$ to 5.5 V, $T_{amb} = -40$ to $+85^\circ\text{C}$, unless otherwise specified

Parameters	Test Conditions / Pins	Symbol	Min.	Typ.	Max.	Unit
Extinction ratio	$V_{11} = 3$ V	$20 \times \log$ ($I_{out,ON}$ $I_{out,off}$)	-40	-50		dB
Output current, transmit mark, ($f_{VCO} = 433.92$ MHz) ³⁾	$V_{11} = 3$ V, $V_{16} = 0$ V Pins 13 and 14	$i_{out,pp}$	2.9	3.5	4.2	mA
Output voltage swing	Difference, Pins 13 and 14	$v_{(13-14)pp}$		4	5	V
Phase detector Output current	Pin 7	I_{PD}	-1		1	mA
Phase detector Output voltage swing ⁴⁾	Pin 7	v_{PDpp}	0.2		$V_S - 0.2$	V
Enable settling time ⁵⁾	Pins 11, 13 and 14	T_{enable}			100	μs
Modulation bandwidth ⁶⁾	Pin 6	BW_{FSK}			50	kHz
Output frequency range	Pins 13 and 14	f_{VCO}	200		500	MHz
XTO frequency range	Pins 9 and 10	f_{XTO}	1		6	MHz
Modulation bandwidth	Pin 16	BW_{ASK}			500	kHz

Notes:

- 3) The output peak-to-peak current is 7 times the current flowing into the AM_in Pin. The driver stage of the power amplifier is designed so that the output current is switched between Pins 13 and 14.
- 4) The output voltage swing at each collector is limited to 2 V due to the circuit arrangement used. The output power depends on the load impedance. If optimum load impedance of 1.1 k Ω is used, an output power of $3.5 \text{ mA}/2 \times \sqrt{2} \times 1.1 \text{ k}\Omega = 1.7 \text{ mW}$ (+2.3 dBm) results.
- 5) This is the time if an external clock is delivered to Pin 9 and Pin 11 is set to V_S until the circuit operates.
- 6) FSK bandwidth is depending on values for loop filter and VCO, see application note for design hints.

Application Circuit (ASK Modulation)

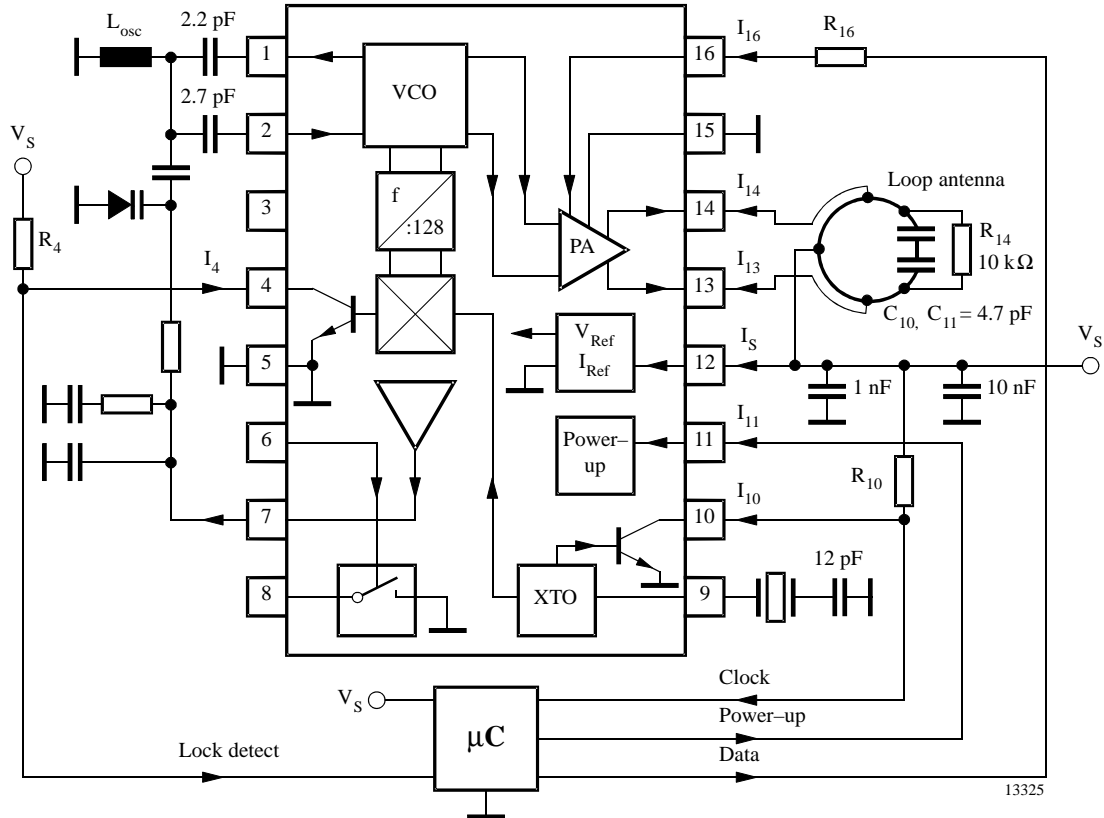

Figure 5.

Principle of Operation (ASK Modulation)

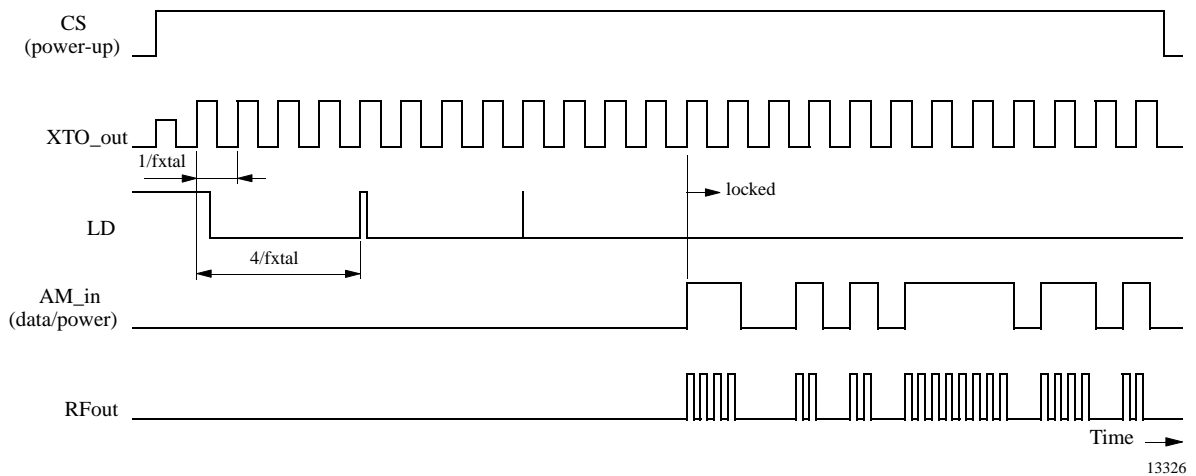

Figure 6.

Application Circuit (FSK Modulation)

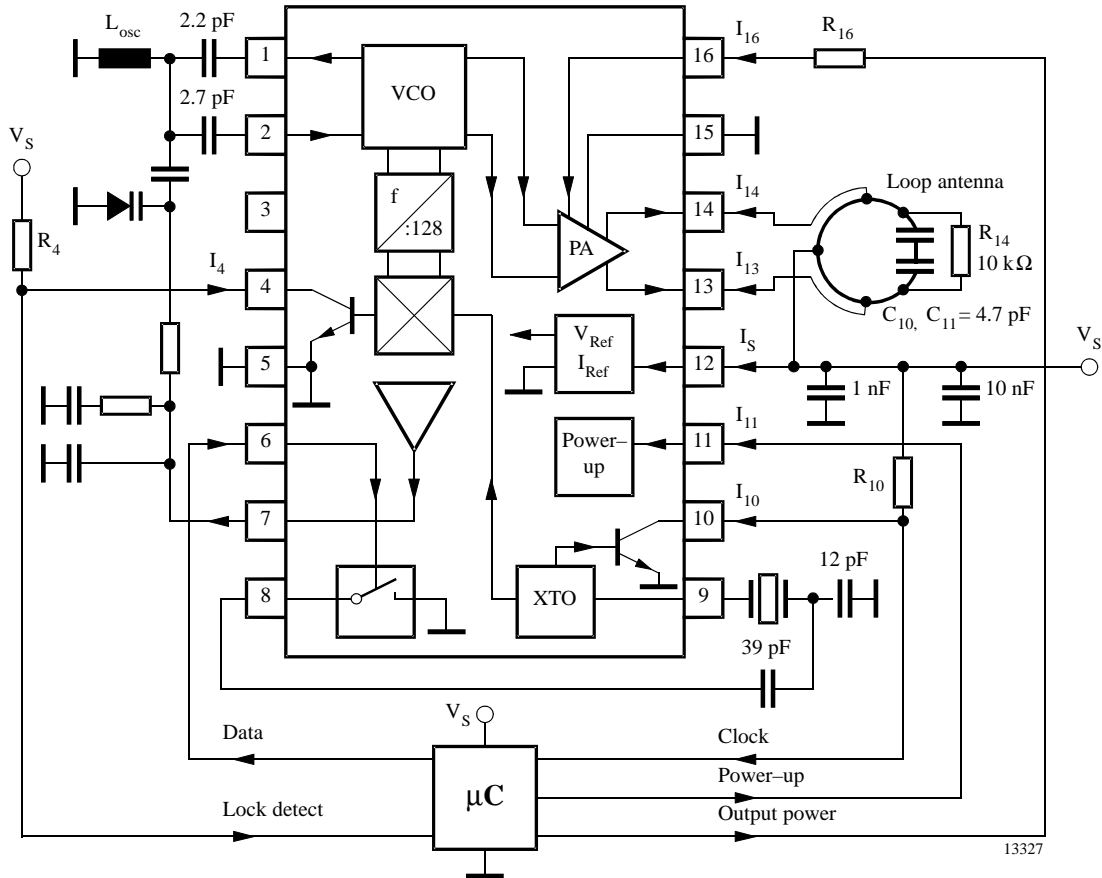

Figure 7.

Principle of Operation (FSK Modulation)

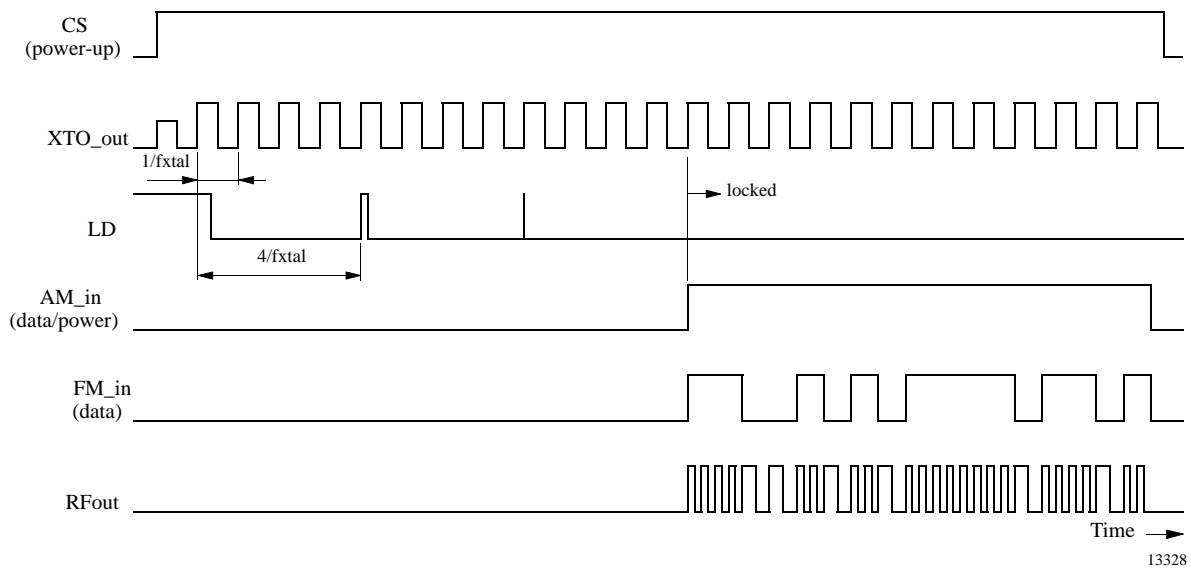
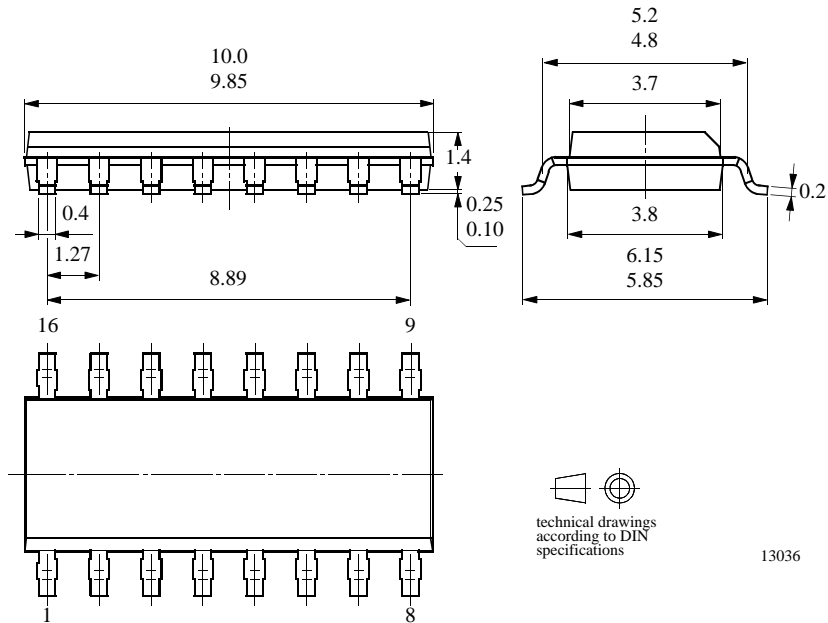

Figure 8.

Package Information

Package SO16

Dimensions in mm



Ozone Depleting Substances Policy Statement

It is the policy of **TEMIC TELEFUNKEN microelectronic GmbH** to

1. Meet all present and future national and international statutory requirements.
2. Regularly and continuously improve the performance of our products, processes, distribution and operating systems with respect to their impact on the health and safety of our employees and the public, as well as their impact on the environment.

It is particular concern to control or eliminate releases of those substances into the atmosphere which are known as ozone depleting substances (ODSs).

The Montreal Protocol (1987) and its London Amendments (1990) intend to severely restrict the use of ODSs and forbid their use within the next ten years. Various national and international initiatives are pressing for an earlier ban on these substances.

TEMIC TELEFUNKEN microelectronic GmbH semiconductor division has been able to use its policy of continuous improvements to eliminate the use of ODSs listed in the following documents.

1. Annex A, B and list of transitional substances of the Montreal Protocol and the London Amendments respectively
2. Class I and II ozone depleting substances in the Clean Air Act Amendments of 1990 by the Environmental Protection Agency (EPA) in the USA
3. Council Decision 88/540/EEC and 91/690/EEC Annex A, B and C (transitional substances) respectively.

TEMIC can certify that our semiconductors are not manufactured with ozone depleting substances and do not contain such substances.

We reserve the right to make changes to improve technical design and may do so without further notice.

Parameters can vary in different applications. All operating parameters must be validated for each customer application by the customer. Should the buyer use TEMIC products for any unintended or unauthorized application, the buyer shall indemnify TEMIC against all claims, costs, damages, and expenses, arising out of, directly or indirectly, any claim of personal damage, injury or death associated with such unintended or unauthorized use.

TEMIC TELEFUNKEN microelectronic GmbH, P.O.B. 3535, D-74025 Heilbronn, Germany
Telephone: 49 (0)7131 67 2831, Fax number: 49 (0)7131 67 2423