

μA741, μA741Y GENERAL-PURPOSE OPERATIONAL AMPLIFIERS

SLOS094B – NOVEMBER 1970 – REVISED SEPTEMBER 2000

- Short-Circuit Protection
- Offset-Voltage Null Capability
- Large Common-Mode and Differential Voltage Ranges
- No Frequency Compensation Required
- Low Power Consumption
- No Latch-Up
- Designed to Be Interchangeable With Fairchild μA741

description

The μA741 is a general-purpose operational amplifier featuring offset-voltage null capability.

The high common-mode input voltage range and the absence of latch-up make the amplifier ideal for voltage-follower applications. The device is short-circuit protected and the internal frequency compensation ensures stability without external components. A low value potentiometer may be connected between the offset null inputs to null out the offset voltage as shown in Figure 2.

The μA741C is characterized for operation from 0°C to 70°C. The μA741I is characterized for operation from -40°C to 85°C. The μA741M is characterized for operation over the full military temperature range of -55°C to 125°C.

symbol

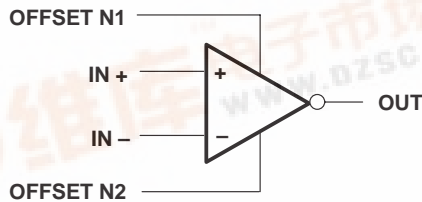

μA741M ... J PACKAGE
(TOP VIEW)

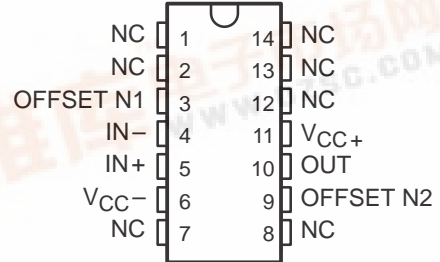

μA741M ... JG PACKAGE
μA741C, μA741I ... D, P, OR PW PACKAGE
(TOP VIEW)

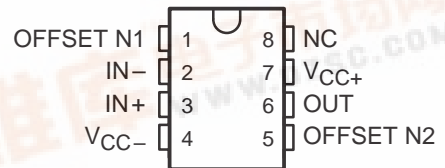

μA741M ... U PACKAGE
(TOP VIEW)

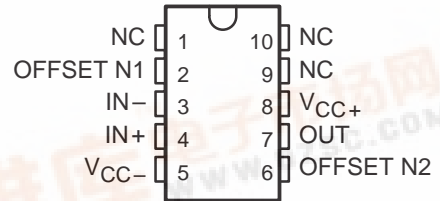

μA741M ... FK PACKAGE
(TOP VIEW)

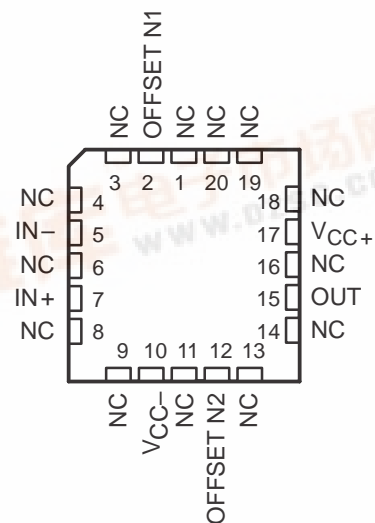

NC – No internal connection



μA741, μA741Y GENERAL-PURPOSE OPERATIONAL AMPLIFIERS

SLOS094B – NOVEMBER 1970 – REVISED SEPTEMBER 2000

AVAILABLE OPTIONS

T _A	PACKAGED DEVICES							CHIP FORM (Y)
	SMALL OUTLINE (D)	CHIP CARRIER (FK)	CERAMIC DIP (J)	CERAMIC DIP (JG)	PLASTIC DIP (P)	TSSOP (PW)	FLAT PACK (U)	
0°C to 70°C	μA741CD				μA741CP	μA741CPW		μA741Y
-40°C to 85°C	μA741ID				μA741IP			
-55°C to 125°C		μA741MFK	μA741MJ	μA741MJG			μA741MU	

The D package is available taped and reeled. Add the suffix R (e.g., μA741CDR).

schematic

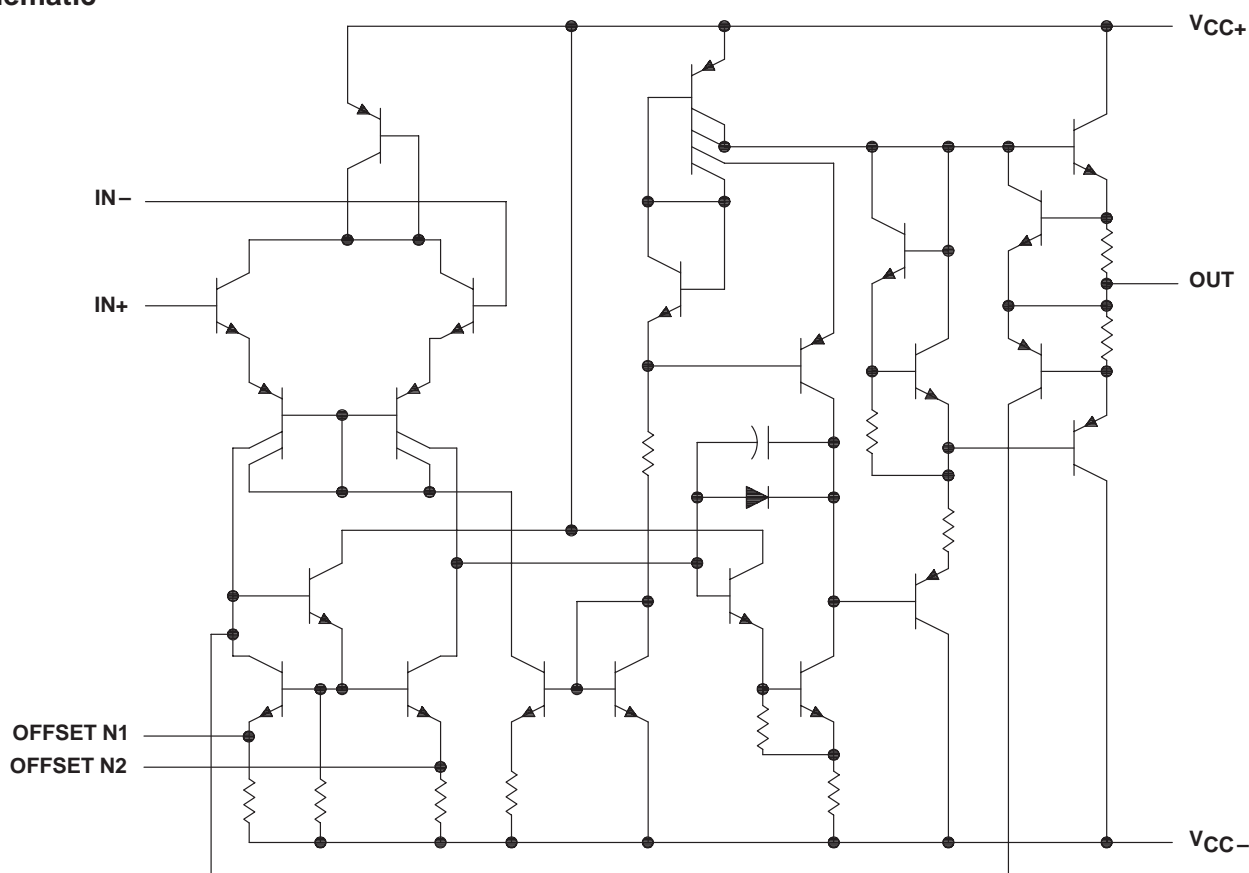

Component Count	
Transistors	22
Resistors	11
Diode	1
Capacitor	1

μA741, μA741Y GENERAL-PURPOSE OPERATIONAL AMPLIFIERS

SLOS094B – NOVEMBER 1970 – REVISED SEPTEMBER 2000

μA741Y chip information

This chip, when properly assembled, displays characteristics similar to the μA741C. Thermal compression or ultrasonic bonding may be used on the doped-aluminum bonding pads. Chips may be mounted with conductive epoxy or a gold-silicon preform.

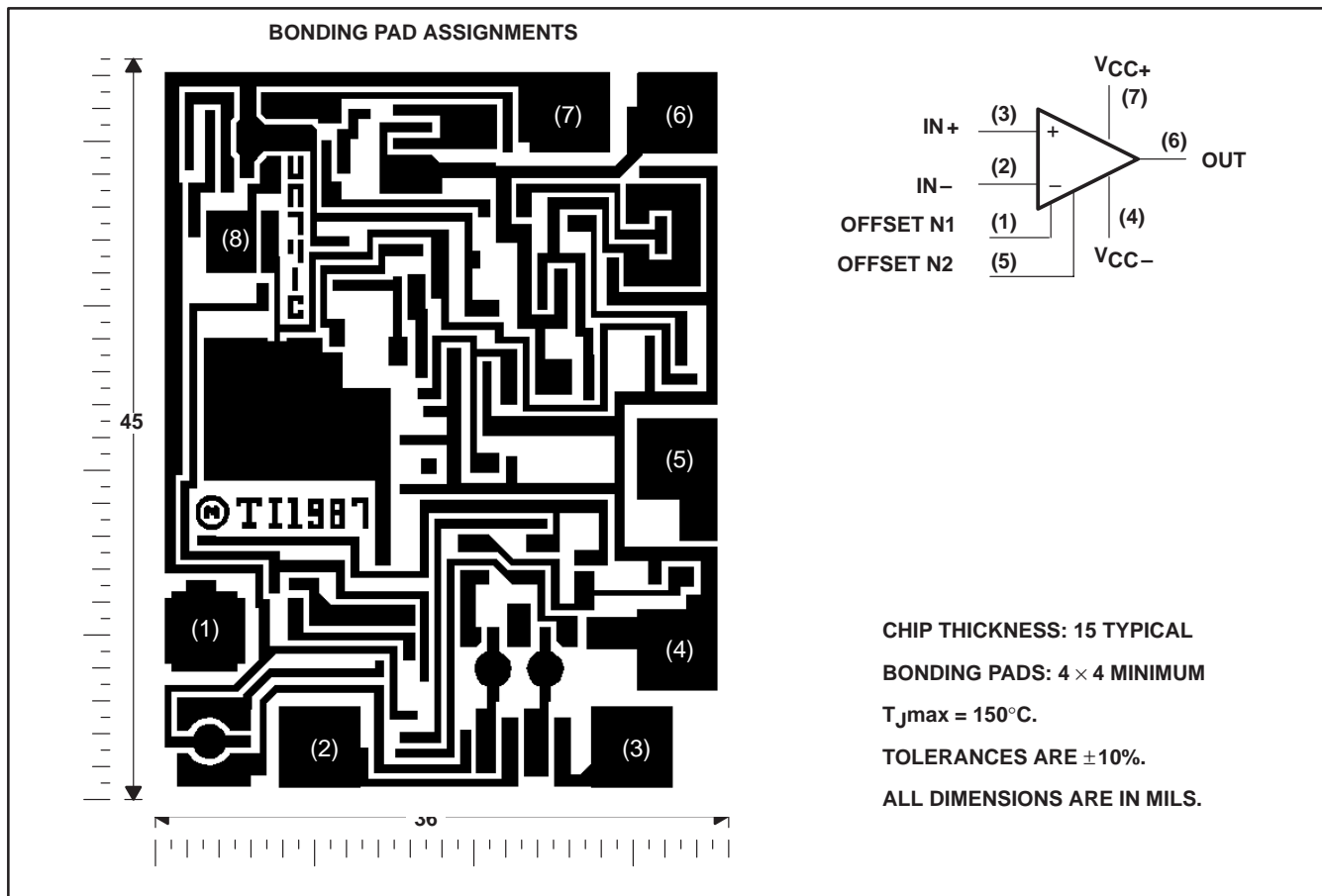

μA741, μA741Y GENERAL-PURPOSE OPERATIONAL AMPLIFIERS

SLOS094B – NOVEMBER 1970 – REVISED SEPTEMBER 2000

absolute maximum ratings over operating free-air temperature range (unless otherwise noted)†

	μA741C	μA741I	μA741M	UNIT
Supply voltage, V_{CC+} (see Note 1)	18	22	22	V
Supply voltage, V_{CC-} (see Note 1)	-18	-22	-22	V
Differential input voltage, V_{ID} (see Note 2)	±15	±30	±30	V
Input voltage, V_I any input (see Notes 1 and 3)	±15	±15	±15	V
Voltage between offset null (either OFFSET N1 or OFFSET N2) and V_{CC-}	±15	±0.5	±0.5	V
Duration of output short circuit (see Note 4)	unlimited	unlimited	unlimited	
Continuous total power dissipation	See Dissipation Rating Table			
Operating free-air temperature range, T_A	0 to 70	-40 to 85	-55 to 125	°C
Storage temperature range	-65 to 150	-65 to 150	-65 to 150	°C
Case temperature for 60 seconds	FK package			260
Lead temperature 1,6 mm (1/16 inch) from case for 60 seconds	J, JG, or U package			300
Lead temperature 1,6 mm (1/16 inch) from case for 10 seconds	D, P, or PW package			260

† Stresses beyond those listed under "absolute maximum ratings" may cause permanent damage to the device. These are stress ratings only, and functional operation of the device at these or any other conditions beyond those indicated under "recommended operating conditions" is not implied. Exposure to absolute-maximum-rated conditions for extended periods may affect device reliability.

- NOTES:
1. All voltage values, unless otherwise noted, are with respect to the midpoint between V_{CC+} and V_{CC-} .
 2. Differential voltages are at $IN+$ with respect to $IN-$.
 3. The magnitude of the input voltage must never exceed the magnitude of the supply voltage or 15 V, whichever is less.
 4. The output may be shorted to ground or either power supply. For the μA741M only, the unlimited duration of the short circuit applies at (or below) 125°C case temperature or 75°C free-air temperature.

DISSIPATION RATING TABLE

PACKAGE	$T_A \leq 25^\circ\text{C}$ POWER RATING	DERATING FACTOR	DERATE ABOVE T_A	$T_A = 70^\circ\text{C}$ POWER RATING	$T_A = 85^\circ\text{C}$ POWER RATING	$T_A = 125^\circ\text{C}$ POWER RATING
D	500 mW	5.8 mW/°C	64°C	464 mW	377 mW	N/A
FK	500 mW	11.0 mW/°C	105°C	500 mW	500 mW	275 mW
J	500 mW	11.0 mW/°C	105°C	500 mW	500 mW	275 mW
JG	500 mW	8.4 mW/°C	90°C	500 mW	500 mW	210 mW
P	500 mW	N/A	N/A	500 mW	500 mW	N/A
PW	525 mW	4.2 mW/°C	25°C	336 mW	N/A	N/A
U	500 mW	5.4 mW/°C	57°C	432 mW	351 mW	135 mW

μA741, μA741Y GENERAL-PURPOSE OPERATIONAL AMPLIFIERS

SLOS094B – NOVEMBER 1970 – REVISED SEPTEMBER 2000

electrical characteristics at specified free-air temperature, $V_{CC\pm} = \pm 15$ V (unless otherwise noted)

PARAMETER	TEST CONDITIONS	T_A †	μA741C			μA741I, μA741M			UNIT
			MIN	TYP	MAX	MIN	TYP	MAX	
V_{IO} Input offset voltage	$V_O = 0$	25°C		1	6		1	5	mV
		Full range			7.5			6	
$\Delta V_{IO(adj)}$ Offset voltage adjust range	$V_O = 0$	25°C		±15			±15		mV
I_{IO} Input offset current	$V_O = 0$	25°C		20	200		20	200	nA
		Full range			300			500	
I_{IB} Input bias current	$V_O = 0$	25°C		80	500		80	500	nA
		Full range			800			1500	
V_{ICR} Common-mode input voltage range		25°C		±12	±13		±12	±13	V
		Full range		±12			±12		
V_{OM} Maximum peak output voltage swing	$R_L = 10$ kΩ	25°C		±12	±14		±12	±14	V
	$R_L \geq 10$ kΩ	Full range		±12			±12		
	$R_L = 2$ kΩ	25°C		±10	±13		±10	±13	
	$R_L \geq 2$ kΩ	Full range		±10			±10		
A_{VD} Large-signal differential voltage amplification	$R_L \geq 2$ kΩ	25°C		20	200		50	200	V/mV
	$V_O = \pm 10$ V	Full range		15			25		
r_i Input resistance		25°C		0.3	2		0.3	2	MΩ
r_o Output resistance	$V_O = 0$, See Note 5	25°C			75			75	Ω
C_i Input capacitance		25°C			1.4			1.4	pF
CMRR Common-mode rejection ratio	$V_{IC} = V_{ICRmin}$	25°C		70	90		70	90	dB
		Full range		70			70		
k_{SVS} Supply voltage sensitivity ($\Delta V_{IO}/\Delta V_{CC}$)	$V_{CC} = \pm 9$ V to ± 15 V	25°C		30	150		30	150	μV/V
		Full range			150			150	
I_{OS} Short-circuit output current		25°C		±25	±40		±25	±40	mA
I_{CC} Supply current	$V_O = 0$, No load	25°C		1.7	2.8		1.7	2.8	mA
		Full range			3.3			3.3	
P_D Total power dissipation	$V_O = 0$, No load	25°C		50	85		50	85	mW
		Full range			100			100	

† All characteristics are measured under open-loop conditions with zero common-mode input voltage unless otherwise specified. Full range for the μA741C is 0°C to 70°C, the μA741I is -40°C to 85°C, and the μA741M is -55°C to 125°C.

NOTE 5: This typical value applies only at frequencies above a few hundred hertz because of the effects of drift and thermal feedback.

operating characteristics, $V_{CC\pm} = \pm 15$ V, $T_A = 25^\circ\text{C}$

PARAMETER	TEST CONDITIONS	μA741C			μA741I, μA741M			UNIT
		MIN	TYP	MAX	MIN	TYP	MAX	
t_r Rise time	$V_I = 20$ mV, $R_L = 2$ kΩ,		0.3			0.3		μs
Overshoot factor	$C_L = 100$ pF, See Figure 1		5%			5%		
SR Slew rate at unity gain	$V_I = 10$ V, $R_L = 2$ kΩ, $C_L = 100$ pF, See Figure 1		0.5			0.5		V/μs

μ A741, μ A741Y GENERAL-PURPOSE OPERATIONAL AMPLIFIERS

SLOS094B – NOVEMBER 1970 – REVISED SEPTEMBER 2000

electrical characteristics at specified free-air temperature, $V_{CC\pm} = \pm 15$ V, $T_A = 25^\circ\text{C}$ (unless otherwise noted)

PARAMETER		TEST CONDITIONS	μ A741Y			UNIT
			MIN	TYP	MAX	
V_{IO}	Input offset voltage	$V_O = 0$		1	6	mV
$\Delta V_{IO(\text{adj})}$	Offset voltage adjust range	$V_O = 0$		± 15		mV
I_{IO}	Input offset current	$V_O = 0$		20	200	nA
I_{IB}	Input bias current	$V_O = 0$		80	500	nA
V_{ICR}	Common-mode input voltage range		± 12	± 13		V
V_{OM}	Maximum peak output voltage swing	$R_L = 10$ k Ω	± 12	± 14		V
		$R_L = 2$ k Ω	± 10	± 13		
A_{VD}	Large-signal differential voltage amplification	$R_L \geq 2$ k Ω	20	200		V/mV
r_i	Input resistance		0.3	2		M Ω
r_o	Output resistance	$V_O = 0$, See Note 5		75		Ω
C_i	Input capacitance			1.4		pF
CMRR	Common-mode rejection ratio	$V_{IC} = V_{ICR\text{min}}$	70	90		dB
k_{SVS}	Supply voltage sensitivity ($\Delta V_{IO}/\Delta V_{CC}$)	$V_{CC} = \pm 9$ V to ± 15 V		30	150	$\mu\text{V/V}$
I_{OS}	Short-circuit output current			± 25	± 40	mA
I_{CC}	Supply current	$V_O = 0$, No load		1.7	2.8	mA
P_D	Total power dissipation	$V_O = 0$, No load		50	85	mW

† All characteristics are measured under open-loop conditions with zero common-mode voltage unless otherwise specified.

NOTE 5: This typical value applies only at frequencies above a few hundred hertz because of the effects of drift and thermal feedback.

operating characteristics, $V_{CC\pm} = \pm 15$ V, $T_A = 25^\circ\text{C}$

PARAMETER		TEST CONDITIONS	μ A741Y			UNIT
			MIN	TYP	MAX	
t_r	Rise time	$V_I = 20$ mV, $R_L = 2$ k Ω ,		0.3		μs
	Overshoot factor	$C_L = 100$ pF, See Figure 1		5%		
SR	Slew rate at unity gain	$V_I = 10$ V, $R_L = 2$ k Ω , $C_L = 100$ pF, See Figure 1		0.5		V/ μs

PARAMETER MEASUREMENT INFORMATION

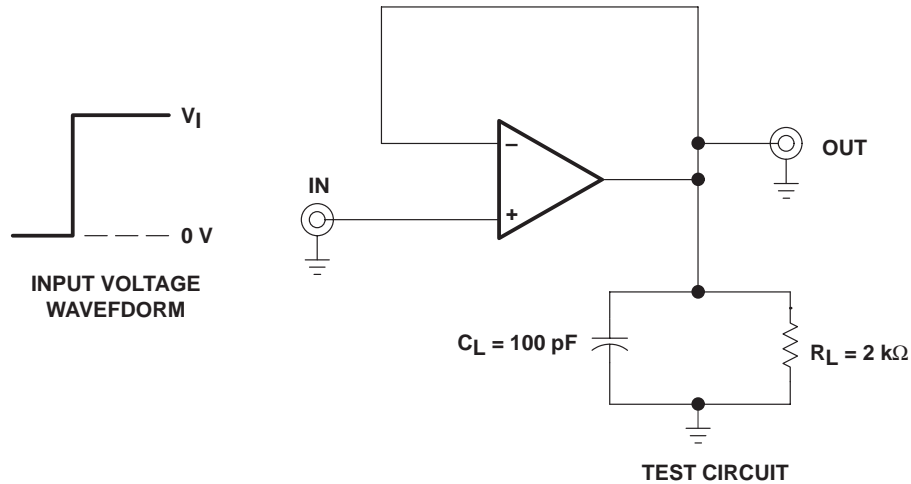

Figure 1. Rise Time, Overshoot, and Slew Rate

APPLICATION INFORMATION

Figure 2 shows a diagram for an input offset voltage null circuit.

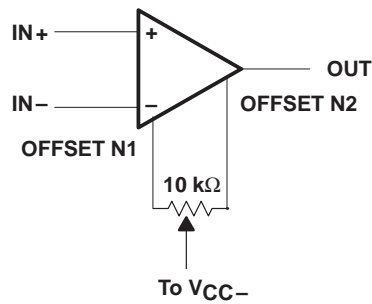

Figure 2. Input Offset Voltage Null Circuit

μ A741, μ A741Y GENERAL-PURPOSE OPERATIONAL AMPLIFIERS

SLOS094B – NOVEMBER 1970 – REVISED SEPTEMBER 2000

TYPICAL CHARACTERISTICS†

INPUT OFFSET CURRENT
vs
FREE-AIR TEMPERATURE

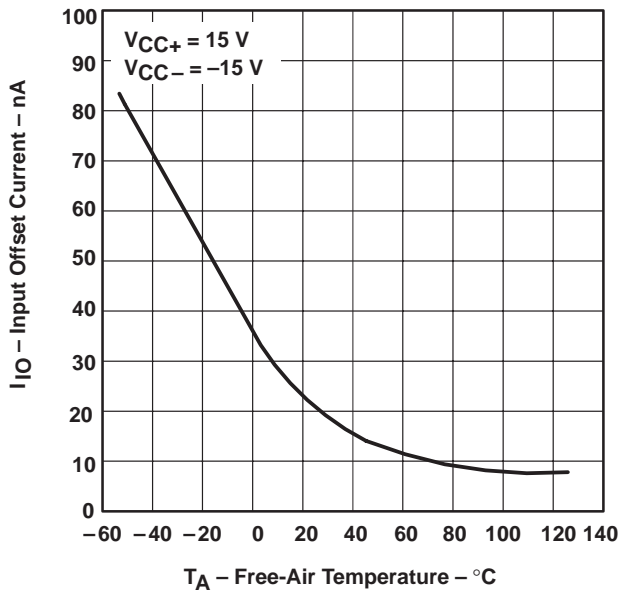

Figure 3

INPUT BIAS CURRENT
vs
FREE-AIR TEMPERATURE

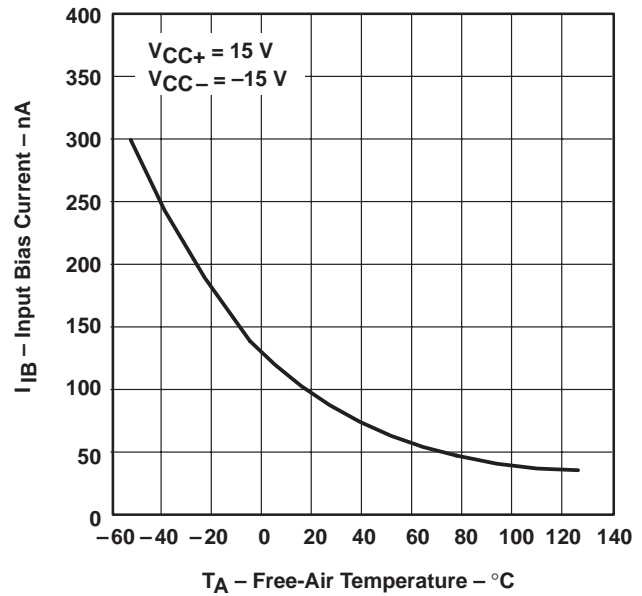

Figure 4

MAXIMUM PEAK OUTPUT VOLTAGE
vs
LOAD RESISTANCE

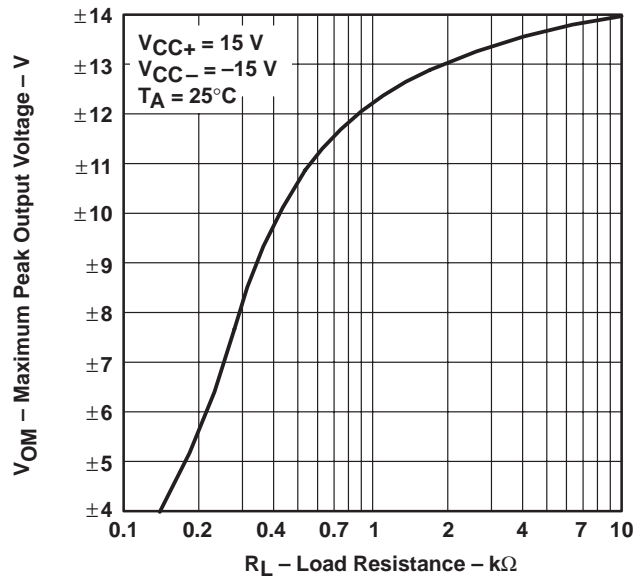

Figure 5

† Data at high and low temperatures are applicable only within the rated operating free-air temperature ranges of the various devices.

μA741, μA741Y GENERAL-PURPOSE OPERATIONAL AMPLIFIERS

SLOS094B – NOVEMBER 1970 – REVISED SEPTEMBER 2000

TYPICAL CHARACTERISTICS

**MAXIMUM PEAK OUTPUT VOLTAGE
vs
FREQUENCY**

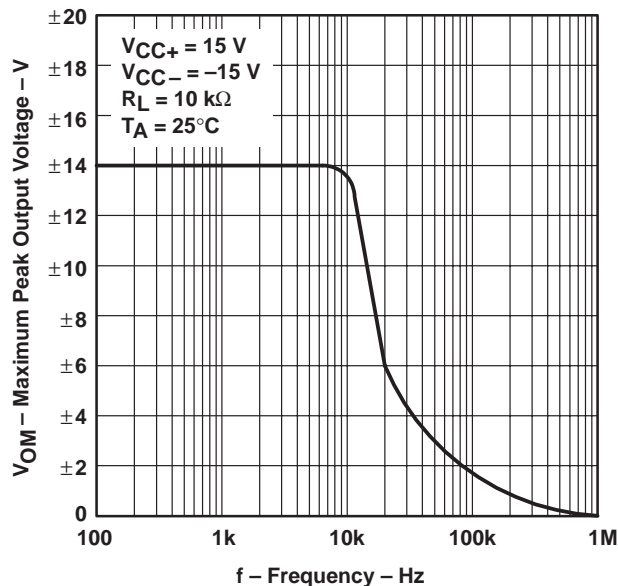

Figure 6

**OPEN-LOOP SIGNAL DIFFERENTIAL
VOLTAGE AMPLIFICATION
vs
SUPPLY VOLTAGE**

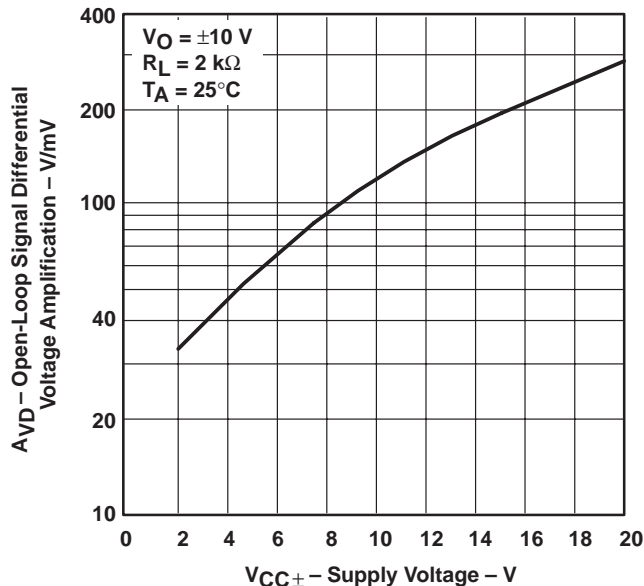
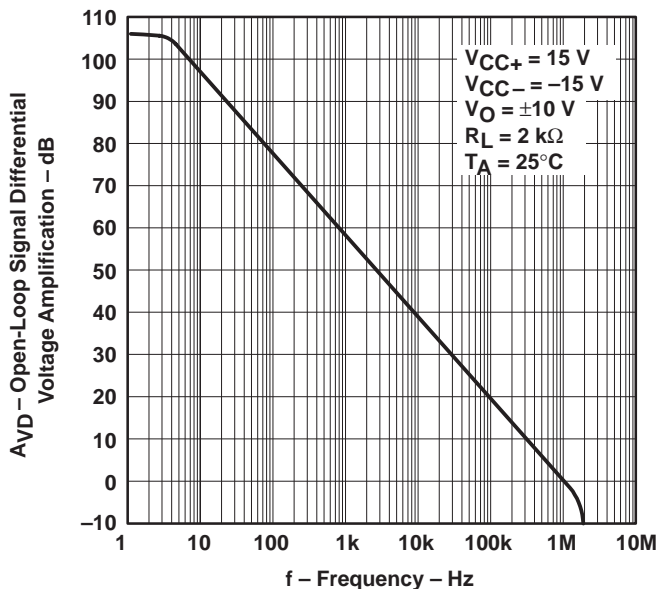

Figure 7

**OPEN-LOOP LARGE-SIGNAL DIFFERENTIAL
VOLTAGE AMPLIFICATION
vs
FREQUENCY**



μ A741, μ A741Y GENERAL-PURPOSE OPERATIONAL AMPLIFIERS

SLOS094B – NOVEMBER 1970 – REVISED SEPTEMBER 2000

TYPICAL CHARACTERISTICS

COMMON-MODE REJECTION RATIO
vs
FREQUENCY

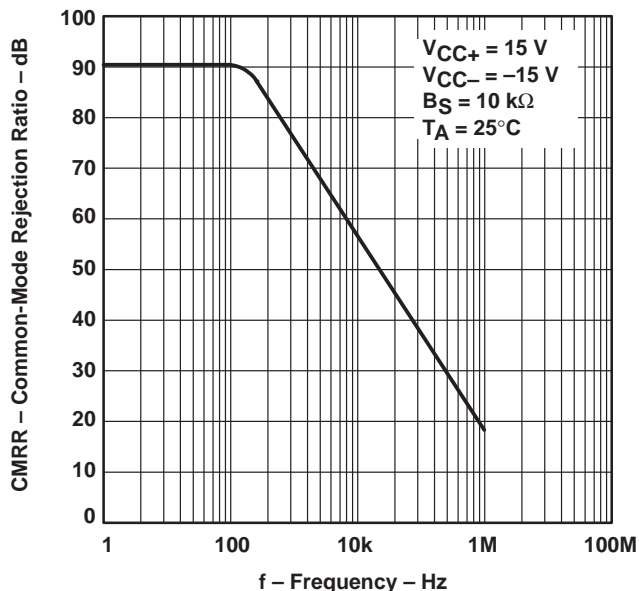

Figure 8

OUTPUT VOLTAGE
vs
ELAPSED TIME

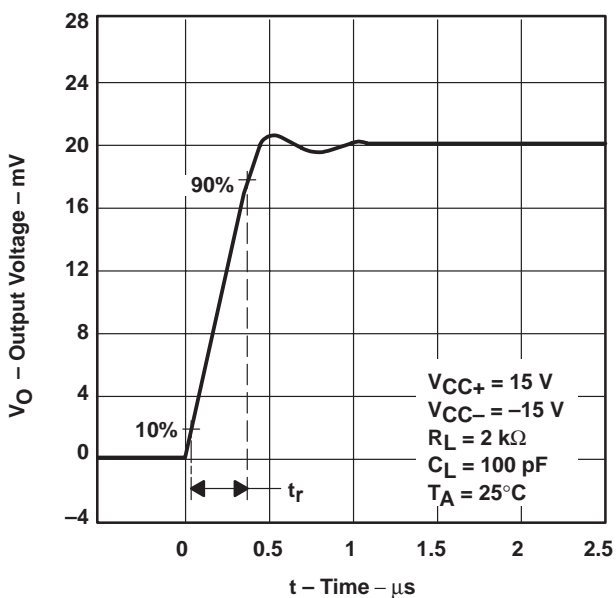

Figure 9

VOLTAGE-FOLLOWER
LARGE-SIGNAL PULSE RESPONSE

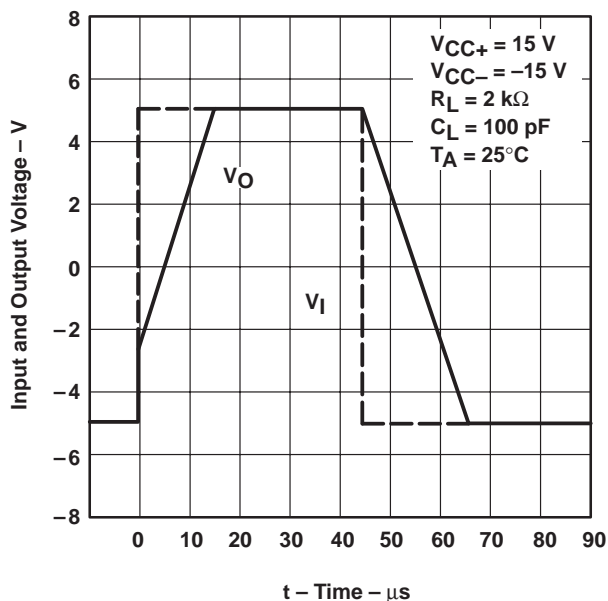

Figure 10

IMPORTANT NOTICE

Texas Instruments and its subsidiaries (TI) reserve the right to make changes to their products or to discontinue any product or service without notice, and advise customers to obtain the latest version of relevant information to verify, before placing orders, that information being relied on is current and complete. All products are sold subject to the terms and conditions of sale supplied at the time of order acknowledgment, including those pertaining to warranty, patent infringement, and limitation of liability.

TI warrants performance of its semiconductor products to the specifications applicable at the time of sale in accordance with TI's standard warranty. Testing and other quality control techniques are utilized to the extent TI deems necessary to support this warranty. Specific testing of all parameters of each device is not necessarily performed, except those mandated by government requirements.

Customers are responsible for their applications using TI components.

In order to minimize risks associated with the customer's applications, adequate design and operating safeguards must be provided by the customer to minimize inherent or procedural hazards.

TI assumes no liability for applications assistance or customer product design. TI does not warrant or represent that any license, either express or implied, is granted under any patent right, copyright, mask work right, or other intellectual property right of TI covering or relating to any combination, machine, or process in which such semiconductor products or services might be or are used. TI's publication of information regarding any third party's products or services does not constitute TI's approval, warranty or endorsement thereof.