

Differential Receiver

The MC100LVEL16 is a differential receiver. The device is functionally equivalent to the EL16 device, operating from a low voltage supply. The LVEL16 exhibits a wider CMR range than its EL16 counterpart. With output transition times and propagation delays comparable to the EL16 the LVEL16 is ideally suited for interfacing with high frequency sources at 3.3V supplies.

The LVEL16 provides a V_{BB} output for either single-ended use or as a DC bias for AC coupling to the device. The V_{BB} pin should be used only as a bias for the LVEL16 as its current sink/source capability is limited. Whenever used, the V_{BB} pin should be bypassed to ground via a $0.01\mu\text{f}$ capacitor.

Under open input conditions, the Q input will be pulled down to V_{EE} and the \bar{Q} input will be biased to $V_{CC}/2$. This condition will force the Q output low.

- 300ps Propagation Delay
- High Bandwidth Output Transitions
- $75\text{k}\Omega$ Internal Input Pulldown Resistors
- $>2000\text{V}$ ESD Protection

LOGIC DIAGRAM AND PINOUT ASSIGNMENT

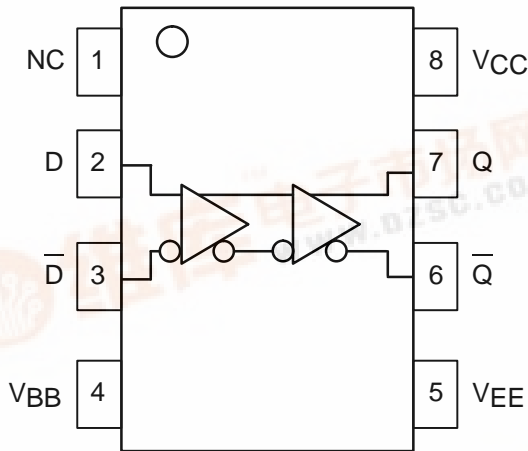

MC100LVEL16



D SUFFIX
PLASTIC SOIC PACKAGE
CASE 751-05

PIN DESCRIPTION

PIN	FUNCTION
D	Data Inputs
Q	Data Outputs
V_{BB}	Ref. Voltage Output



MC100LVEL16

DC CHARACTERISTICS ($V_{EE} = V_{EE}(\text{min})$ to $V_{EE}(\text{max})$; $V_{CC} = \text{GND}$)

Symbol	Characteristic	-40°C			0°C			25°C			85°C			Unit
		Min	Typ	Max	Min	Typ	Max	Min	Typ	Max	Min	Typ	Max	
I_{EE}	Power Supply Current		17	23		17	23		17	23		18	24	mA
V_{BB}	Output Reference Voltage	-1.38		-1.26	-1.38		-1.26	-1.38		-1.26	-1.38		-1.26	V
V_{EE}	Power Supply Voltage	-3.0	-3.3	-3.8	-3.0	-3.3	-3.8	-3.0	-3.3	-3.8	-3.0	-3.3	-3.8	V
I_{IH}	Input HIGH Current			150			150			150			150	μA
I_{IL}	Input LOW Current	$\frac{D}{D}$	0.5		0.5			0.5			0.5			μA
			-600		-600			-600			-600			

AC CHARACTERISTICS ($V_{EE} = V_{EE}(\text{min})$ to $V_{EE}(\text{max})$; $V_{CC} = \text{GND}$)

Symbol	Characteristic	-40°C			0°C			25°C			85°C			Unit
		Min	Typ	Max	Min	Typ	Max	Min	Typ	Max	Min	Typ	Max	
t_{PLH} t_{PHL}	Propagation Delay to Output (Diff) (SE)	150 100	275 275	400 450	215 165	290 290	365 415	225 175	300 300	375 425	240 190	315 315	390 440	ps
t_{SKEW}	Duty Cycle Skew ¹ (Diff)		5	30		5	20		5	20		5	20	ps
V_{PP}	Minimum Input Swing ²	150			150			150			150			mV
V_{CMR}	Common Mode Range ³ $V_{PP} < 500\text{mV}$ $V_{PP} \geq 500\text{mV}$	-2.0 -1.8		-0.4 -0.4	-2.1 -1.9		-0.4 -0.4	-2.1 -1.9		-0.4 -0.4	-2.1 -1.9		-0.4 -0.4	V
t_r t_f	Output Rise/Fall Times Q (20% - 80%)	120	220	320	120	220	320	120	220	320	120	220	320	ps

1. Duty cycle skew is the difference between a TPLH and TPHL propagation delay through a device.
2. Minimum input swing for which AC parameters guaranteed. The device has a DC gain of ≈ 40 .
3. The CMR range is referenced to the most positive side of the differential input signal. Normal operation is obtained if the HIGH level falls within the specified range and the peak-to-peak voltage lies between V_{ppmin} and 1V. The lower end of the CMR range varies 1:1 with V_{EE} . The numbers in the spec table assume a nominal $V_{EE} = -3.3\text{V}$. Note for PECL operation, the $V_{CMR}(\text{min})$ will be fixed at $3.3\text{V} - |V_{CMR}(\text{min})|$.

OUTLINE DIMENSIONS

D SUFFIX
PLASTIC SOIC PACKAGE
CASE 751-05
ISSUE M

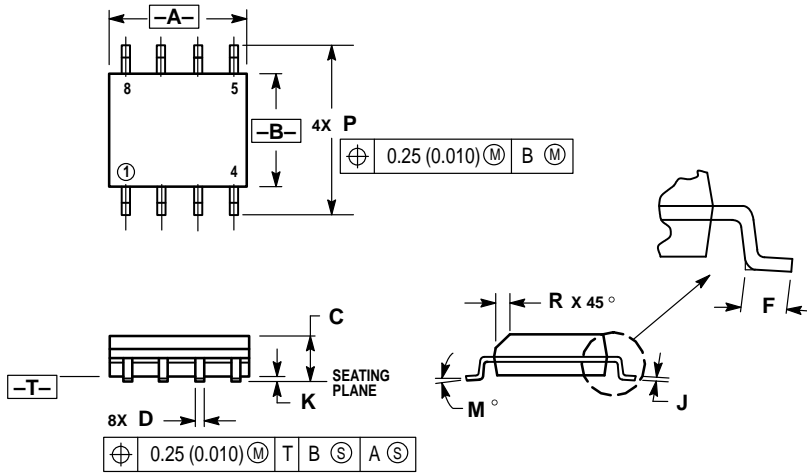

- NOTES:
1. DIMENSIONING AND TOLERANCING PER ANSI Y14.5M, 1982.
 2. CONTROLLING DIMENSION: MILLIMETER.
 3. DIMENSIONS A AND B DO NOT INCLUDE MOLD PROTRUSION.
 4. MAXIMUM MOLD PROTRUSION 0.15 (0.006) PER SIDE.
 5. DIMENSION D DOES NOT INCLUDE DAMBAR PROTRUSION. ALLOWABLE DAMBAR PROTRUSION SHALL BE 0.127 (0.005) TOTAL IN EXCESS OF THE D DIMENSION AT MAXIMUM MATERIAL CONDITION.

DIM	MILLIMETERS		INCHES	
	MIN	MAX	MIN	MAX
A	4.80	5.00	0.189	0.196
B	3.80	4.00	0.150	0.157
C	1.35	1.75	0.054	0.068
D	0.35	0.49	0.014	0.019
F	0.40	1.25	0.016	0.049
G	1.27 BSC		0.050 BSC	
J	0.18	0.25	0.007	0.009
K	0.10	0.25	0.004	0.009
M	0°	7°	0°	7°
P	5.80	6.20	0.229	0.244
R	0.25	0.50	0.010	0.019

Motorola reserves the right to make changes without further notice to any products herein. Motorola makes no warranty, representation or guarantee regarding the suitability of its products for any particular purpose, nor does Motorola assume any liability arising out of the application or use of any product or circuit, and specifically disclaims any and all liability, including without limitation consequential or incidental damages. "Typical" parameters which may be provided in Motorola data sheets and/or specifications can and do vary in different applications and actual performance may vary over time. All operating parameters, including "Typicals" must be validated for each customer application by customer's technical experts. Motorola does not convey any license under its patent rights nor the rights of others. Motorola products are not designed, intended, or authorized for use as components in systems intended for surgical implant into the body, or other applications intended to support or sustain life, or for any other application in which the failure of the Motorola product could create a situation where personal injury or death may occur. Should Buyer purchase or use Motorola products for any such unintended or unauthorized application, Buyer shall indemnify and hold Motorola and its officers, employees, subsidiaries, affiliates, and distributors harmless against all claims, costs, damages, and expenses, and reasonable attorney fees arising out of, directly or indirectly, any claim of personal injury or death associated with such unintended or unauthorized use, even if such claim alleges that Motorola was negligent regarding the design or manufacture of the part. Motorola and are registered trademarks of Motorola, Inc. Motorola, Inc. is an Equal Opportunity/Affirmative Action Employer.

How to reach us:

USA/EUROPE/Locations Not Listed: Motorola Literature Distribution;
P.O. Box 20912; Phoenix, Arizona 85036. 1-800-441-2447 or 602-303-5454

JAPAN: Nippon Motorola Ltd.; Tatsumi-SPD-JLDC, 6F Seibu-Butsuryu-Center,
3-14-2 Tatsumi Koto-Ku, Tokyo 135, Japan. 03-81-3521-8315

MFAX: RMFAX0@email.sps.mot.com - TOUCHTONE 602-244-6609
INTERNET: http://Design-NET.com

ASIA/PACIFIC: Motorola Semiconductors H.K. Ltd.; 8B Tai Ping Industrial Park,
51 Ting Kok Road, Tai Po, N.T., Hong Kong. 852-26629298