



1%-Accurate, Digitally Trimmed Sensor Signal Conditioner

MAX1458

General Description

The MAX1458 highly integrated analog-sensor signal processor is optimized for piezoresistive sensor calibration and compensation without any external components. It includes a programmable current source for sensor excitation, a 3-bit programmable-gain amplifier (PGA), a 128-bit internal EEPROM, and four 12-bit DACs. Achieving a total error factor within 1% of the sensor's repeatability errors, the MAX1458 compensates offset, offset temperature coefficient, full-span output (FSO), FSO temperature coefficient (FSOTC), and FSO nonlinearity of silicon piezoresistive sensors.

The MAX1458 calibrates and compensates first-order temperature errors by adjusting the offset and span of the input signal via digital-to-analog converters (DACs), thereby eliminating quantization noise. Built-in testability features on the MAX1458 result in the integration of three traditional sensor-manufacturing operations into one automated process:

- **Pretest:** Data acquisition of sensor performance under the control of a host test computer.
- **Calibration and compensation:** Computation and storage (in an internal EEPROM) of calibration and compensation coefficients computed by the test computer and downloaded to the MAX1458.
- **Final test operation:** Verification of transducer calibration and compensation without removal from the pretest socket.

Although optimized for use with piezoresistive sensors, the MAX1458 may also be used with other resistive sensors (i.e., accelerometers and strain gauges) with some additional external components.

Customization

Maxim can customize the MAX1458 for unique requirements. With a dedicated cell library consisting of more than 90 sensor-specific functional blocks, Maxim can quickly provide customized MAX1458 solutions. Please contact Maxim for further information.

Applications

- Piezoresistive Pressure and Acceleration Transducers and Transmitters
- MAP (Manifold Absolute Pressure) Sensors
- Automotive Systems
- Hydraulic Systems
- Industrial Pressure Sensors

Features

- ◆ **Medium Accuracy ($\pm 1\%$), Single-Chip Sensor Signal Conditioning**
- ◆ **Sensor Errors Trimmed Using Correction Coefficients Stored in Internal EEPROM—Eliminates the Need for Laser Trimming and Potentiometers**
- ◆ **Compensates Offset, Offset-TC, FSO, FSOTC, FSO Linearity**
- ◆ **Programmable Current Source (0.1mA to 2.0mA) for Sensor Excitation**
- ◆ **Fast Signal-Path Settling Time (<1ms)**
- ◆ **Accepts Sensor Outputs from 10mV/V to 40mV/V**
- ◆ **Fully Analog Signal Path**

Ordering Information

PART	TEMP. RANGE	PIN-PACKAGE
MAX1458CAE	0°C to +70°C	16 SSOP
MAX1458C/D	0°C to +70°C	Dice*
MAX1458AAE	-40°C to +125°C	16 SSOP

*Dice are tested at $T_A = +25^\circ\text{C}$, DC parameters only.

Functional Diagram appears at end of data sheet.

Pin Configuration

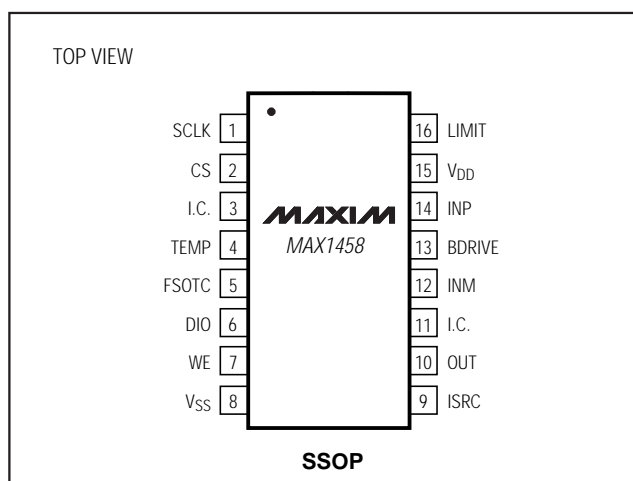

1%-Accurate, Digitally Trimmed Sensor Signal Conditioner

ABSOLUTE MAXIMUM RATINGS

Supply Voltage, V_{DD} to V_{SS} -0.3V to +6V
 All Other Pins ($V_{SS} - 0.3V$) to ($V_{DD} + 0.3V$)
 Short-Circuit Duration, FSOTC, OUT, BDRIVE Continuous
 Continuous Power Dissipation ($T_A = +70^\circ\text{C}$)
 SSOP (derate 8.00mW/ $^\circ\text{C}$ above $+70^\circ\text{C}$) 640mW

Operating Temperature Ranges
 MAX1458CAE 0°C to $+70^\circ\text{C}$
 MAX1458AAE -40°C to $+125^\circ\text{C}$
 Storage Temperature Range -65°C to $+160^\circ\text{C}$
 Lead Temperature (soldering, 10sec) $+300^\circ\text{C}$

Stresses beyond those listed under "Absolute Maximum Ratings" may cause permanent damage to the device. These are stress ratings only, and functional operation of the device at these or any other conditions beyond those indicated in the operational sections of the specifications is not implied. Exposure to absolute maximum rating conditions for extended periods may affect device reliability.

ELECTRICAL CHARACTERISTICS

($V_{DD} = +5V$, $V_{SS} = 0$, $T_A = +25^\circ\text{C}$, unless otherwise noted.)

PARAMETER	SYMBOL	CONDITIONS	MIN	TYP	MAX	UNITS
GENERAL CHARACTERISTICS						
Supply Voltage	V_{DD}		4.5	5.0	5.5	V
Supply Current	I_{DD}	(Note 1)		3	6	mA
ANALOG INPUT (PGA)						
Input Impedance	R_{IN}			1		$M\Omega$
Input-Referred Offset Tempco		(Notes 2, 3)		± 0.5		$\mu\text{V}/^\circ\text{C}$
Amplifier Gain Nonlinearity				0.01		$\%V_{DD}$
Output Step Response		63% of final value		1		ms
Common-Mode Rejection Ratio	CMRR	From V_{SS} to V_{DD}		90		dB
Input-Referred Adjustable Offset Range		At minimum gain (Note 4)		± 150		mV
Input-Referred Adjustable FSO Range		(Note 5)		10 to 40		mV/V
ANALOG OUTPUT (PGA)						
Differential Signal-Gain Range		Selectable in eight steps		41 to 230		V/V
Minimum Differential Signal Gain		$T_A = T_{MIN}$ to T_{MAX}	36	41	45	V/V
Differential Signal-Gain Tempco				± 50		ppm/ $^\circ\text{C}$
Output Voltage Swing		$V_{LIMIT} = 5.0V$, no load	$V_{SS} + 0.15$		$V_{DD} - 0.25$	V
		$V_{LIMIT} = 4.6V$	10k Ω load to V_{SS} or V_{DD}	$V_{SS} + 0.25$	$V_{LIMIT} \pm 0.3$	
			No load	$V_{SS} + 0.1$	$V_{LIMIT} \pm 0.2$	
Output Current Range		$V_{LIMIT} = 4.6V$, $V_{OUT} = (V_{SS} + 0.25V)$ to $(V_{LIMIT} - 0.3V)$	-0.45 (sink)		0.45 (source)	mA
Output Noise		DC to 10Hz (gain = 41, source impedance = 5k Ω)		500		μVRMS

1%-Accurate, Digitally Trimmed Sensor Signal Conditioner

MAX1458

ELECTRICAL CHARACTERISTICS (continued)

(V_{DD} = +5V, V_{SS} = 0, T_A = +25°C, unless otherwise noted.)

PARAMETER	SYMBOL	CONDITIONS	MIN	TYP	MAX	UNITS
CURRENT SOURCE						
Bridge Current Range	I _{BDRIVE}		0.1	0.5	2.0	mA
Bridge Voltage Swing	V _{BDRIVE}		V _{SS} + 1.3		V _{DD} - 1.3	V
Reference Input Voltage Range (ISRC)	V _{ISRC}		V _{SS} + 1.3		V _{DD} - 1.3	V
DIGITAL-TO-ANALOG CONVERTERS						
DAC Resolution					12	Bits
Differential Nonlinearity	DNL			±1.5		LSB
Offset DAC Bit Weight	$\frac{\Delta V_{OUT}}{\Delta Code}$	DAC reference = V _{DD} = 5.0V		2.8		mV/bit
Offset TC DAC Bit Weight	$\frac{\Delta V_{OUT}}{\Delta Code}$	DAC reference = V _{BDRIVE} = 2.5V		1.4		mV/bit
FSO DAC Bit Weight	$\frac{\Delta V_{ISRC}}{\Delta Code}$	DAC reference = V _{DD} = 5.0V		1.22		mV/bit
FSO TC DAC Bit Weight	$\frac{\Delta V_{FSOTC}}{\Delta Code}$	DAC reference = V _{BDRIVE} = 2.5V		0.6		mV/bit
IRO DAC						
DAC Resolution				3		Bits
DAC Bit Weight		Input referred, V _{DD} = 5V (Note 6)		9		mV/bit
FSOTC BUFFER						
Output Voltage Swing		No load	V _{SS} + 0.3		V _{DD} - 1.3	V
Current Drive		V _{FSOTC} = 2.5V	-20		20	μA
INTERNAL RESISTORS						
Current-Source Reference Resistor	R _{ISRC}			75		kΩ
FSO Trim Resistor	R _{FTC}			75		kΩ
Temperature-Dependent Resistor	R _{TEMP}	Typically 4600ppm/°C tempco		100		kΩ

Note 1: Excludes the sensor or load current.

Note 2: All electronics temperature errors are compensated together with sensor errors.

Note 3: The sensor and the MAX1458 must always be at the same temperature during calibration and use.

Note 4: This is the maximum allowable sensor offset.

Note 5: This is the sensor's sensitivity normalized to its drive voltage, assuming a desired full-span output of 4V and a bridge voltage of 2.5V.

Note 6: Bit weight is ratiometric to V_{DD}.

1%-Accurate, Digitally Trimmed Sensor Signal Conditioner

Pin Description

PIN	NAME	FUNCTION
1	SCLK	Data Clock Input. Used only during programming/testing. Internally pulled to V _{SS} with a 1M Ω (typical) resistor. Data is clocked in on the rising edge of the clock. The maximum SCLK frequency is 10kHz.
2	CS	Chip-Select Input. The MAX1458 is selected when this pin is high. When low, OUT and DIO become high impedance. Internally pulled to V _{DD} with a 1M Ω (typical) resistor. Leave unconnected for normal operation.
3, 11	I.C.	Internally Connected. Leave unconnected.
4	TEMP	Temperature Sensor Output. An internal temperature sensor (a 100k Ω , 4600ppm/ $^{\circ}$ C TC resistor) which can provide a temperature-dependent voltage.
5	FSOTC	Buffered FSOTC DAC Output. An internal 75k Ω resistor (R _{FTC}) connects FSOTC to ISRC (see <i>Functional Diagram</i>). Optionally, external resistors can be used in place of or in parallel with R _{FTC} and R _{ISRC} .
6	DIO	Data Input/Output. Used only during programming/testing. Internally pulled to V _{SS} with a 1M Ω (typical) resistor. High impedance when CS is low.
7	WE	Dual-Function Input Pin. Used to enable EEPROM erase/write operations. Also used to set the DAC refresh-rate mode. Internally pulled to V _{DD} with a 1M Ω (typical) resistor. Refer to the <i>Chip-Select (CS) and Write-Enable (WE)</i> section.
8	V _{SS}	Negative Power-Supply Input
9	ISRC	Current-Source Reference. An internal 75k Ω resistor (R _{ISRC}) connects ISRC to V _{SS} (see <i>Functional Diagram</i>). Optionally, external resistors can be used in place of or in parallel with R _{FTC} and R _{ISRC} .
10	OUT	PGA Output Voltage
12	INM	Negative Sensor Input. Input impedance >1M Ω . Rail-to-rail input range.
13	BDRIVE	Sensor Excitation Current Output. This current source drives the bridge.
14	INP	Positive Sensor Input. Input impedance >1M Ω . Rail-to-rail input range.
15	V _{DD}	Positive Power-Supply Input. Connect a 0.1 μ F capacitor from V _{DD} to V _{SS} .
16	LIMIT	Voltage Limit Input. This pin sets the maximum voltage at OUT. If left unconnected, the output voltage will be limited to 4.6V (V _{DD} = 5V). Connect to V _{DD} for maximum output swing. The acceptable range is 4.5V \leq V _{LIMIT} \leq V _{DD} .

Detailed Description

The MAX1458 provides an analog amplification path for the sensor signal. Calibration and temperature compensation are achieved by varying the offset and gain of a programmable-gain amplifier (PGA) and by varying the sensor bridge current. The PGA uses a switched-capacitor CMOS technology, with an input-referred coarse offset trimming range of approximately ± 63 mV (9mV steps). An additional output-referred fine offset trim is provided by the Offset DAC (approximately 2.8mV steps). The PGA provides eight gain values from +41V/V to +230V/V. The bridge current source is programmable from 0.1mA to 2mA.

The MAX1458 uses four 12-bit DACs and one 3-bit DAC, with calibration coefficients stored by the user in

an internal 128-bit EEPROM. This memory contains the following information as 12-bit-wide words:

- Configuration register
- Offset calibration coefficient
- Offset temperature error compensation coefficient
- FSO (full-span output) calibration coefficient
- FSO temperature error compensation coefficient
- 24 user-defined bits for customer programming of manufacturing data (e.g., serial number and date)

Figure 1 shows a typical pressure-sensor output and defines the offset, full-scale, and full-span output values as a function of voltage.

1%-Accurate, Digitally Trimmed Sensor Signal Conditioner

FSOTC Compensation

Silicon piezoresistive transducers (PRTs) exhibit a large positive input resistance tempco (TCR) so that, while under constant current excitation, the bridge voltage (V_{BDRIVE}) increases with temperature. This dependence of V_{BDRIVE} on the sensor temperature can be used to compensate the sensor temperature errors. PRTs also have a large negative full-span output sensitivity tempco (TCS) so that, with constant voltage excitation, full-span output (FSO) will decrease with temperature, causing a full-span output temperature coefficient (FSOTC) error. However, if the bridge voltage can be made to increase with temperature at the same rate that TCS decreases with temperature, the FSO will remain constant.

FSOTC compensation is accomplished by resistor R_{FTC} and the FSOTC DAC, which modulate the excitation reference current at ISRC as a function of temperature (Figure 3). FSO DAC sets V_{ISRC} and remains constant with temperature while the voltage at FSOTC varies with temperature. FSOTC is the buffered output of the FSOTC DAC. The reference DAC voltage is V_{BDRIVE} , which is temperature dependent. The FSOTC DAC alters the tempco of the current source. When the tempco of the bridge voltage is equal in magnitude and opposite in polarity to the TCS, the FSOTC errors are compensated and FSO will be constant with temperature.

OFFSET TC Compensation

Compensating offset TC errors involves first measuring the uncompensated offset TC error, then determining the percentage of the temperature-dependent voltage

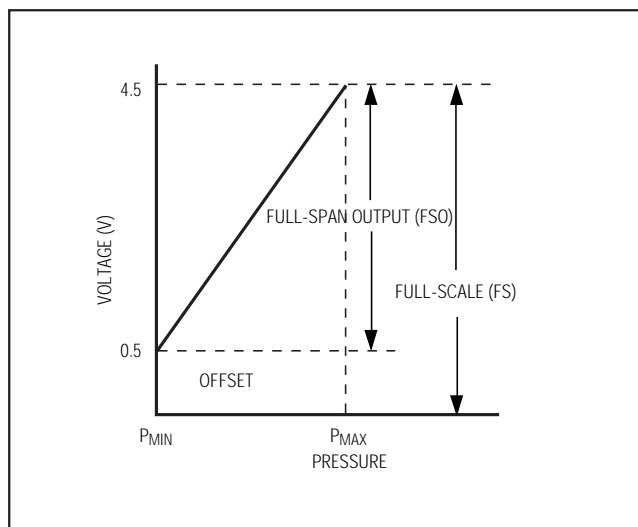

Figure 1. Typical Pressure-Sensor Output

V_{BDRIVE} that must be added to the output summing junction to correct the error. Use the Offset TC DAC to adjust the amount of $BDRIVE$ voltage that is added to the output summing junction (Figure 2).

Analog Signal Path

The fully differential analog signal path consists of four stages:

- Front-end summing junction for coarse offset correction
- 3-bit PGA with eight selectable gains ranging from 41 through 230
- Three-input-channel summing junction
- Differential to single-ended output buffer (Figure 2)

Coarse Offset Correction

The sensor output is first fed into a differential summing junction (INM (negative input) and INP (positive input)) with a CMRR > 90dB, an input impedance of approximately $1M\Omega$, and a common-mode input voltage range from V_{SS} to V_{DD} . At this summing junction, a coarse offset-correction voltage is added, and the resultant voltage is fed into the PGA. The 3-bit (plus sign) input-referred Offset DAC (IRO DAC) generates the coarse offset-correction voltage. The DAC voltage reference is 1.25% of V_{DD} ; thus, a V_{DD} of 5V results in a front-end offset-correction voltage ranging from -63mV to +63mV, in 9mV steps (Table 1). To add an offset to the input signal, set the IRO sign bit high; to subtract an offset from the input signal, set the IRO sign bit low. The IRO DAC bits (C2, C1, C0, and IRO sign bit) are programmed in the configuration register (see *Internal EEPROM* section).

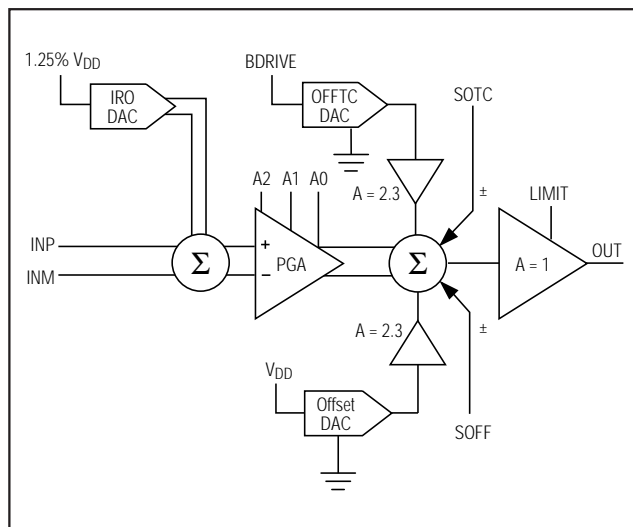

Figure 2. Signal-Path Block Diagram

1%-Accurate, Digitally Trimmed Sensor Signal Conditioner

Table 1. Input-Referred Offset DAC Correction Values

IRO DAC					OFFSET CORRECTION % of V _{DD} (%)	OFFSET CORRECTION AT V _{DD} = 5V (mV)
VALUE	SIGN	C2	C1	C0		
+7	1	1	1	1	+1.25	+63
+6	1	1	1	0	+1.08	+54
+5	1	1	0	1	+0.90	+45
+4	1	1	0	0	+0.72	+36
+3	1	0	1	1	+0.54	+27
+2	1	0	1	0	+0.36	+18
+1	1	0	0	1	+0.18	+9
+0	1	0	0	0	0	0
-0	0	0	0	0	0	0
-1	0	0	0	1	-0.18	-9
-2	0	0	1	0	-0.36	-18
-3	0	0	1	1	-0.54	-27
-4	0	1	0	0	-0.72	-36
-5	0	1	0	1	-0.90	-45
-6	0	1	1	0	-1.08	-54
-7	0	1	1	1	-1.25	-63

Programmable-Gain Amplifier

The programmable-gain amplifier (PGA), which is used to set the coarse FSO, uses a switched-capacitor CMOS technology and contains eight selectable gain levels from 41 to 230, in increments of 27 (Table 2). The output of the PGA is fed to the output summing junction. The three PGA gain bits A2, A1, and A0 are stored in the configuration register.

Output Summing Junction

The third stage in the analog signal path consists of a summing junction for the PGA output, offset correction, and the offset TC correction. Both the offset and the offset TC correction voltages are gained by a factor of 2.3 before being fed into the summing junction, increasing the offset and offset TC correction range. The offset sign bit and offset TC sign bit are stored in the configuration register. The offset sign bit determines if the offset correction voltage is added to (sign bit is high) or subtracted from (sign bit is low) the PGA output. Negative offset TC errors require a logic high for the offset TC sign bit. Alternately, positive offset TC errors dictate a logic low for the offset TC sign bit. The output of the summing junction is fed to the output buffer.

Table 2. PGA Gain Settings and IRO DAC Step Size

PGA VALUE	A2	A1	A0	PGA GAIN (V/V)	OUTPUT-REFERRED IRO DAC STEP SIZE (V _{DD} = 5V) (V)
0	0	0	0	41	0.369
1	0	0	1	68	0.612
2	0	1	0	95	0.855
3	0	1	1	122	1.098
4	1	0	0	149	1.341
5	1	0	1	176	1.584
6	1	1	0	203	1.827
7	1	1	1	230	2.070

Output Buffer

OUT can drive 0.1μF of capacitance. If CS is brought low, OUT becomes high impedance (resulting in typical output impedance of 1MΩ). The output is current limited and can be shorted to either V_{DD} or V_{SS} indefinitely.

The maximum output voltage can be limited using the LIMIT pin. Output limiting can be performed for sensor diagnostic purposes. Connect LIMIT to V_{DD} to disable the voltage-limiting feature.

Bridge Drive

Fine FSO correction is accomplished by varying the sensor excitation current with the 12-bit FSO DAC (Figure 3). Sensor bridge excitation is performed by a programmable current source capable of delivering up to 2mA. The reference current at ISRC is established by resistor R_{ISRC} and by the voltage at node ISRC (controlled by the FSO DAC). The reference current flowing through this pin is multiplied by a current mirror (AA = 14) and then made available at BDRIVE for sensor excitation. Modulation of this current with respect to temperature can be used to correct FSOTC errors, while modulation with respect to the output voltage (V_{OUT}) can be used to correct FSO linearity errors.

Digital-to-Analog Converters

The four 12-bit, sigma-delta DACs typically settle in less than 100ms. The four DACs have a corresponding memory register in EEPROM for storage of correction coefficients.

Use the FSO DAC for fine FSO adjustments. The FSO DAC takes its reference from V_{DD} and controls V_{ISRC} which, in conjunction with R_{ISRC}, sets the baseline sensor excitation current. The Offset DAC also takes its reference from V_{DD} and provides a 1.22mV resolution with

1%-Accurate, Digitally Trimmed Sensor Signal Conditioner

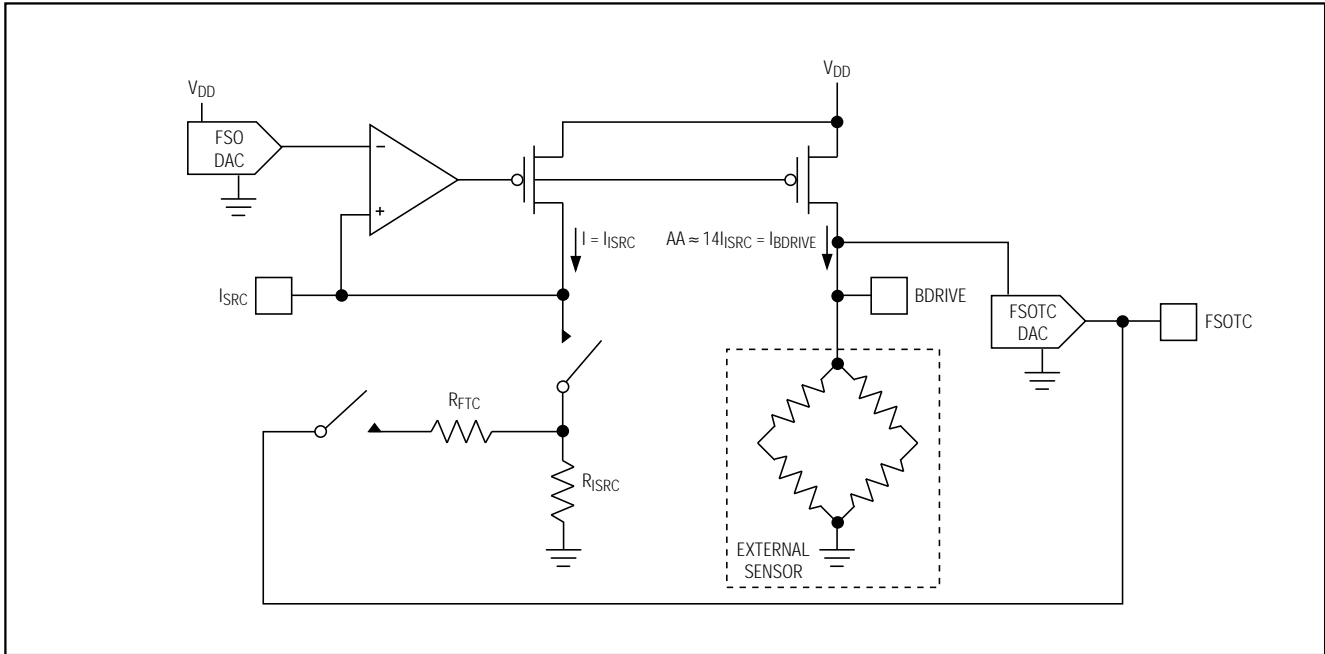

Figure 3. Bridge Excitation Circuit

a V_{DD} of 5V. The output of the Offset DAC is fed into the output summing junction where it is gained by approximately 2.3, which increases the resulting output-referred offset correction resolution to 2.8mV.

Both the Offset TC and FSOTC DACs take their reference from BDRIVE, a temperature-dependent voltage. A nominal V_{BDRIVE} of 2.5V results in a step size of 0.6mV. The Offset TC DAC output is fed into the output summing junction where it is gained by approximately 2.3, thereby increasing the Offset TC correction range. The buffered FSOTC DAC output is available at FSOTC and is connected to ISRC via R_{FTC} to correct FSOTC errors.

Internal Resistors

The MAX1458 contains three internal resistors (R_{ISRC} , R_{FTC} , and R_{TEMP}) optimized for common silicon PRTs. R_{ISRC} (in conjunction with the FSO DAC) programs the nominal sensor excitation current. R_{FTC} (in conjunction with the FSOTC DAC) compensates the FSOTC errors. Both R_{ISRC} and R_{FTC} have a nominal value of 75k Ω . If external resistors are used, R_{ISRC} and R_{FTC} can be disabled by resetting the appropriate bit (address 07h reset to zero) in the configuration register (Table 3).

R_{TEMP} is a high-tempco resistor with a TC of +4600ppm/ $^{\circ}$ C and a nominal resistance of 100k Ω at +25 $^{\circ}$ C. This resistor can be used with certain sensor types that require an external temperature sensor.

Table 3. Configuration Register

EEPROM ADDRESS (hex)	DESCRIPTION
00h	Offset TC Sign Bit, SOTC
01h	Offset Sign Bit, SOFF
02h	PGA Gain (MSB), A2
03h	PGA Gain, A1
04h	PGA Gain (LSB), A0
05h	Reserved "0"
06h	Reserved "0"
07h	Internal Resistor (R_{FTC} and R_{ISRC}) Selection
08h	Input-Referred Offset (IRO) Sign Bit
09h	Input-Referred Offset (MSB)
0Ah	Input-Referred Offset
0Bh	Input-Referred Offset (LSB)

Internal EEPROM

The MAX1458 has a 128-bit internal EEPROM arranged as eight 16-bit words. The four uppermost bits for each register are reserved. The internal EEPROM is used to store the following (also shown in the memory map in Table 4):

1%-Accurate, Digitally Trimmed Sensor Signal Conditioner

Table 4. EEPROM Memory Map

EE Address	0F	0E	0D	0C	0B	0A	09	08	07	06	05	04	03	02	01	00
Contents	1	0	0	0	Configuration											
EE Address	1F	1E	1D	1C	1B	1A	19	18	17	16	15	14	13	12	11	10
Contents	1	0	0	1	MSB	Offset										LSB
EE Address	2F	2E	2D	2C	2B	2A	29	28	27	26	25	24	23	22	21	20
Contents	1	0	1	0	MSB	Offset TC										LSB
EE Address	3F	3E	3D	3C	3B	3A	39	38	37	36	35	34	33	32	31	30
Contents	1	0	1	1	MSB	FSO										LSB
EE Address	4F	4E	4D	4C	4B	4A	49	48	47	46	45	44	43	42	41	40
Contents	1	1	0	0	MSB	FSOTC										LSB
Reserved*	5F	5E	5D	5C	5B	5A	59	58	57	56	55	54	53	52	51	50
	0	0	0	0	0	0	0	0	0	0	0	0	0	0	0	0
EE Address	6F	6E	6D	6C	6B	6A	69	68	67	66	65	64	63	62	61	60
Contents	0	0	0	0	User defined bits											
EE Address	7F	7E	7D	7C	7B	7A	79	78	77	76	75	74	73	72	71	70
Contents	0	0	0	0	User defined bits											
	<div style="display: inline-block; width: 15px; height: 15px; background-color: #cccccc; border: 1px solid black;"></div> = Reserved Bits															
Note: The MAX1458 processes the Reserved Bits in the EEPROM. If these bits are not properly programmed, the configuration and DAC registers will not be updated correctly.																
* The contents of the Reserved EE Address 50–5F must all be reset to zero.																

- Configuration register (Table 3)
- 12-bit calibration coefficients for the Offset and FSO DACs
- 12-bit compensation coefficients for the Offset TC and FSOTC DACs
- Two general-purpose registers available to the user for storing process information such as serial number, batch date, and check sums

Program the EEPROM one bit at a time. The bits have addresses from 0 to 127 (7F hex).

Configuration Register

The configuration register (Table 3) determines the PGA gain, the polarity of the offset and offset TC coefficients, and the coarse offset correction (IRO DAC). It also enables/disables internal resistors (R_{FTC} and R_{ISRC}).

DAC Registers

The Offset, Offset TC, FSO, and FSOTC registers store the coefficients used by their respective calibration/compensation DACs.

1%-Accurate, Digitally Trimmed Sensor Signal Conditioner

Detailed Description of the Digital Lines

Chip-Select (CS) and Write-Enable (WE)

CS is used to enable OUT, control serial communication, and force an update of the configuration and DAC registers.

- A low on CS disables serial communication and places OUT in a high-impedance state.
- A transition from low to high on CS forces an update of the configuration and DAC registers from the EEPROM when the “U” bit is zero.
- A transition from high to low on CS terminates programming mode.
- A logic high on CS enables OUT and serial communication (see *Communication Protocol* section).

WE controls the refresh rate for the internal configuration and DAC registers from the EEPROM and enables the erase/write operations. If communication has been initiated (see *Communication Protocol* section), internal register refresh is disabled.

- A low on WE disables the erase/write operations and also disables register refreshing from the EEPROM.
- A high on WE selects a refresh rate of approximately 400 times per second and enables EEPROM erase/write operations.
- It is recommended that WE be connected to V_{SS} after the MAX1458 EEPROM has been programmed.

SCLK (Serial Clock)

SCLK must be driven externally and is used to input commands to the MAX1458 and read EEPROM contents. Input data on DIO is latched on the rising edge of SCLK. Noise on SCLK may disrupt communication. In noisy environments, place a capacitor (0.01 μ F) between SCLK and V_{SS} .

Data Input/Output (DIO)

The DIO line is an input/output pin used to issue commands to the MAX1458 (input mode) or read the EEPROM contents (output mode).

In input mode (the default mode), data on DIO is latched on each rising edge of SCLK. Therefore, data on DIO must be stable at the rising edge of SCLK and should transition on the falling edge of SCLK.

DIO will switch to output mode after receiving a “READ EEPROM” command, and will return the data bit addressed by the digital value in the “READ EEPROM” command. After a low-to-high transition or CS, DIO returns to input mode and is ready to accept more commands.

Communication Protocol

To initiate communication, the first six bits on DIO after CS transitions from low to high **must** be 1010U0 (defined as the INIT SEQUENCE). The MAX1458 will then begin accepting 16-bit control words (Figure 4).

If the INIT SEQUENCE is not detected, all subsequent data on DIO is ignored until CS again transitions from low to high and the correct INIT SEQUENCE is received.

The “U” bit of the INIT SEQUENCE controls the updating of the DACs and configuration register from the internal EEPROM. If this bit is low (U = 0), all four internal DACs and the configuration register will be updated from the EEPROM on the next rising edge of CS (this is also the default on power-up). If the “U” bit is high, the DACs and configuration register will not be updated from the internal EEPROM; they will retain their current value on any subsequent CS rising edge. The MAX1458 continues to accept control words until CS is brought low.

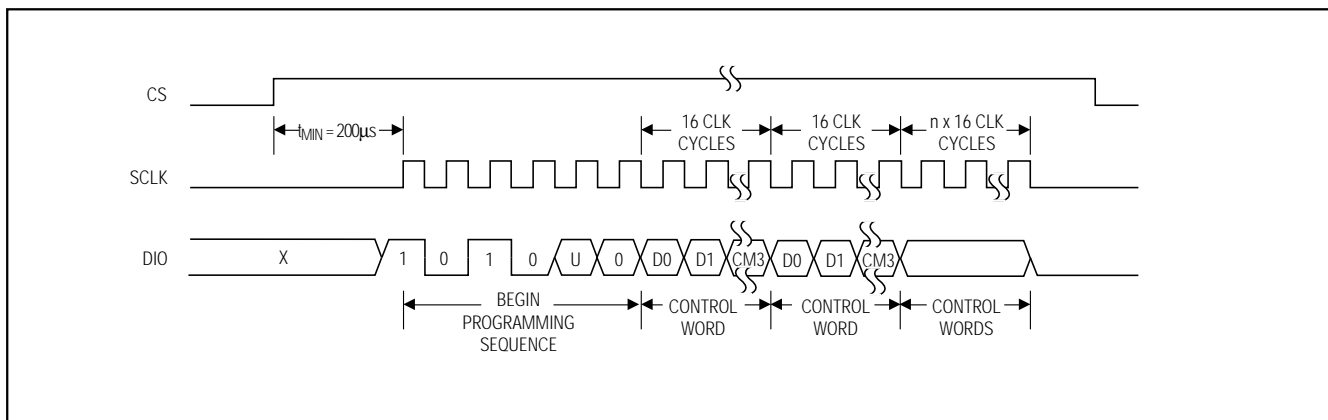

Figure 4. Communication Sequence

1%-Accurate, Digitally Trimmed Sensor Signal Conditioner

Control Words

After receiving the INIT SEQUENCE on DIO, the MAX1458 begins latching in 16-bit control words, LSB first (Figure 5).

The first 12 bits (D0–D11) represent the data field. The last four bits of the control word (the MSBs, CM0–CM3) are the command field. The MAX1458 supports the commands listed in Table 5.

ERASE EEPROM Command

When an ERASE EEPROM command is issued, all of the memory locations in the EEPROM are reset to a logic “0.” The data field of the 16-bit word is ignored.

Important: An internal charge pump develops voltages greater than 20V for EEPROM programming operations. The EEPROM control logic requires 50ms to erase the EEPROM. After sending a WRITE or ERASE command, failure to wait 50ms before issuing another command may result in data being accidentally written to the EEPROM. The maximum number of ERASE EEPROM cycles should not exceed 100.

BEGIN EEPROM WRITE Command

The BEGIN EEPROM WRITE command stores a logic high at the memory location specified by the lower seven bits of the data field (A0–A6). The higher bits of the data field (A7–A11) are ignored (Figure 6). Note that to write to the internal EEPROM, WE and CS must be

Table 5. MAX1458 Commands

FUNCTION	HEX CODE	CM3	CM2	CM1	CM0
ERASE EEPROM	1h	0	0	0	1
BEGIN EEPROM WRITE at Address	2h	0	0	1	0
READ EEPROM at Address	3h	0	0	1	1
Maxim Reserved	4h	0	1	0	0
END EEPROM WRITE at Address	5h	0	1	0	1
WRITE Data to Configuration Register	8h	1	0	0	0
WRITE Offset DAC	9h	1	0	0	1
WRITE Offset TC DAC	Ah	1	0	1	0
WRITE FSO DAC	Bh	1	0	1	1
WRITE FSOTC DAC	Ch	1	1	0	0
No Operation	0h	0	0	0	0
Load Register	6h	0	1	1	0
	7h	0	1	1	1
	Dh	1	1	0	1
	Eh	1	1	1	0
	Fh	1	1	1	1

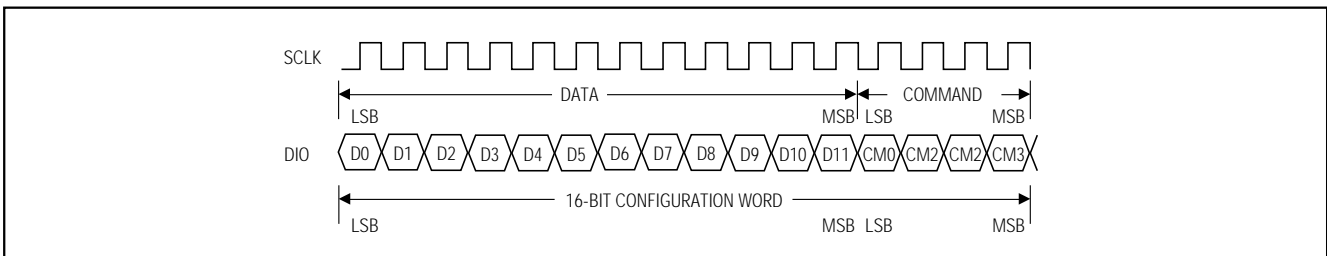

Figure 5. Control-Word Timing Diagram

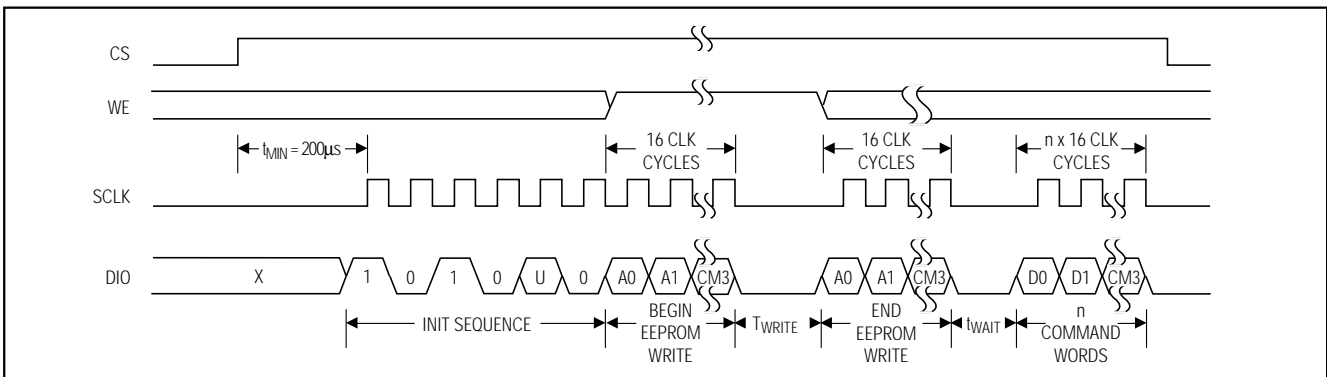

Figure 6. Timing Diagram for WRITE EEPROM Operation

1%-Accurate, Digitally Trimmed Sensor Signal Conditioner

high. In addition, the EEPROM should only be written to at $T_A = +25^\circ\text{C}$ and $V_{DD} = 5\text{V}$.

Writing to the internal EEPROM is a time-consuming process and should only be required once. All calibration/compensation coefficients are determined by writing directly to the DAC and configuration registers. Use the following procedure to write these calibration/compensation coefficients to the EEPROM:

- 1) Issue an ERASE EEPROM command.
- 2) Wait 50ms (t_{WRITE}).
- 3) Issue on END EEPROM WRITE command at address 00h.
- 4) Wait 1ms (t_{WAIT}).
- 5) Issue a BEGIN EEPROM WRITE command (Figure 7) at the address of the bit to be set.
- 6) Wait 50ms.
- 7) Issue an END EEPROM WRITE command (Figure 7) using the same address as in Step 5.

- 8) Wait 1ms.
- 9) Return to Step 5 until all necessary bits have been set.
- 10) Read EEPROM to verify that the correct calibration/compensation coefficients have been stored.

READ EEPROM Command

The READ EEPROM command returns the bit stored at the memory location addressed by the lower seven bits of the data field (A0–A6). The higher bits of the data field (A7–A11) are ignored. Note that after a read command has been issued, the DIO lines become an output and the state of the addressed EEPROM location will be available on DIO $200\mu\text{s}$ (t_{READ}) after the falling edge of the 16th SCLK cycle (Figure 8). After issuing the READ EEPROM command, DIO returns to input mode on the falling edge of CS. Reading the entire EEPROM requires the READ EEPROM command be issued 128 times.

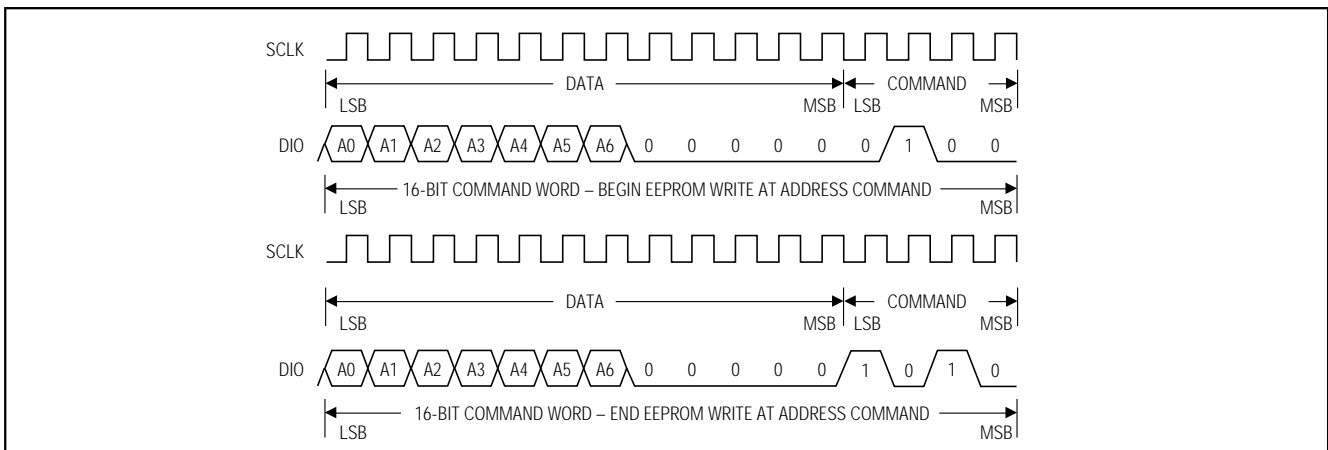

Figure 7. Begin WRITE EEPROM and End WRITE EEPROM Timing Diagrams

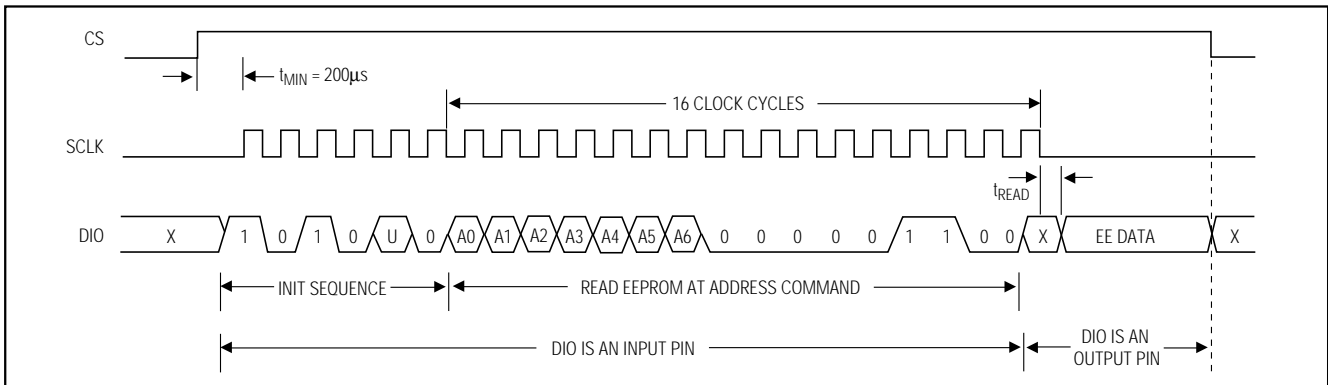

Figure 8. READ EEPROM Timing Diagram

1%-Accurate, Digitally Trimmed Sensor Signal Conditioner

Writing to the Configuration and DAC Registers

When writing to the configuration register or directly to the internal 12-bit DACs, the data field (D0–D11) contains the data to be written to the respective register. Note that all four DACs and the configuration register can be updated without toggling the CS line. Every register write command must be followed by a LOAD REGISTER command.

Applications Information

Power-Up

At power up, the following occurs:

- 1) The DAC and configuration registers are reset to zero.
- 2) CS transitions from low to high after power-up (an internal pull-up resistor ensures that this happens if CS is left unconnected), and the EEPROM contents are read and processed.
- 3) The DAC and configuration registers are updated either once or approximately 400 times per second (as determined by the state of WE).
- 4) The MAX1458 begins accepting commands in a serial format on DIO immediately after receiving the INIT SEQUENCE.

The MAX1458 is shipped with all memory locations in the internal EEPROM uninitialized. Therefore, the MAX1458 **must** be programmed for proper operation.

Compensation Procedure

The following compensation procedure was used to obtain the results shown in Figure 9 and Table 8. It assumes a pressure transducer with a +5V supply and an output voltage that is ratiometric to the supply voltage. The desired offset voltage (V_{OUT} at P_{MIN}) is 0.5V, and the desired FSO voltage ($V_{OUT(P_{MAX})} - V_{OUT(P_{MIN})}$) is 4V; thus the full-scale output voltage (V_{OUT} at P_{MAX}) will be 4.5V (refer to Figure 1). The procedure requires a minimum of two test pressures (e.g., zero and full scale) at two arbitrary test temperatures, T_1 and T_2 . Ideally, T_1 and T_2 are the two points where we wish to perform best linear fit compensation. The following outlines a typical compensation procedure:

- 1) Perform Coefficient Initialization
- 2) Perform FSO Calibration
- 3) Perform FSOTC Compensation
- 4) Perform Offset TC Compensation
- 5) Perform Offset Calibration

Coefficient Initialization

Select the resistor values and the PGA gain to prevent overload of the PGA and bridge current source. These values depend on sensor behavior and require some sensor characterization data, which may be available from the sensor manufacturer. If not, the data can be generated by performing a two-temperature, two-pressure sensor evaluation. The required sensor information is shown in Table 6 and can be used to obtain the values for the parameters listed in Table 7.

Table 6. Sensor Information for Typical PRT

PARAMETER	SENSOR DESCRIPTION	TYPICAL VALUES
Rb(T)	Bridge Impedance	5k Ω at +25°C
TCR	Bridge Impedance Tempco	2600ppm/°C
S(T)	Sensitivity	1.5mV/V per PSI at +25°C
TCS	Sensitivity Tempco	-2100ppm/°C
O(T)	Offset	12mV/V at +25°C
OTC	Offset Tempco	-1000ppm/°C of FSO
S(p)	Sensitivity Linearity Error as % FSO, BSLF (Best Straight-Line Fit)	0.1% FSO, BSLF
P _{MIN}	Minimum Input Pressure	0 PSI
P _{MAX}	Maximum Input Pressure	10 PSI

Selecting R_{ISRC}

When using an external resistor, use the equation below to determine the value of R_{ISRC} , and place the resistor between ISRC and V_{SS} . Since the 12-bit FSO DAC provides considerable dynamic range, the R_{ISRC} value need not be exact. Generally any resistor value within $\pm 50\%$ of the calculated value is acceptable. If both the internal resistors R_{ISRC} and R_{FTC} are used, set the IRS bit at EEPROM address bit 7 high. Otherwise, set IRS low and connect external resistors as shown in Figure 10.

$$R_{ISRC} \approx 14 \times R_b(T_1) \\ \approx 14 \times 5k\Omega = 70k\Omega$$

where $R_b(T)$ is the sensor input impedance at temperature T_1 (+25°C in this example).

1%-Accurate, Digitally Trimmed Sensor Signal Conditioner

Table 7. Compensation Components and Values

PARAMETER	DESCRIPTION
R _{ISRC}	Internal (approximately 75kΩ) or user-supplied resistor that programs the nominal sensor excitation current.
R _{FTC}	Internal (approximately 75kΩ) or user-supplied resistor that compensates FSO TC errors.
A _{PGA}	Programmable-gain amplifier gain
I _{RO}	Input-referred offset correction DAC value
I _{RO} Sign	Input-referred offset sign bit
I _{RS}	Internal resistor selection bit
OFF COEF	Offset correction DAC coefficient
OFF Sign	Offset sign bit
OFFTC COEF	Offset TC compensation DAC coefficient
OFFTC Sign	Offset TC sign bit
FSO COEF	FSO trim DAC coefficient
FSOTC COEF	FSO TC compensation DAC coefficient

Selecting R_{FTC}

When using an external resistor, use the equation below to determine the value for R_{FTC}, and place the resistor between ISRC and FSOTC. Since the 12-bit FSOTC DAC provides considerable dynamic range, the R_{FTC} value need not be exact. Generally, any resistor value within ±50% of the calculated value is acceptable.

$$R_{FTC} \cong \frac{R_{ISRC} \times 500\text{ppm}/^{\circ}\text{C}}{\text{TCR} - |\text{TCS}|}$$

$$\cong \frac{70\text{k}\Omega \times 500\text{ppm}/^{\circ}\text{C}}{2600\text{ppm}/^{\circ}\text{C} - |-2100\text{ppm}/^{\circ}\text{C}|} = 70\text{k}\Omega$$

This approximation works best for bulk, micromachined, silicon PRTs. Negative values for R_{FTC} indicate unconventional sensor behavior that cannot be compensated by the MAX1458 without additional external circuitry.

Selecting the PGA Gain Setting

To select the PGA gain setting, first calculate SensorFSO, the sensor full-span output voltage at T1:

$$\text{SensorFSO} = S \times V_{\text{BDRIVE}} \times \Delta P$$

$$= 1.5\text{mV/V per PSI} \times 2.5\text{V} \times 10\text{ PSI}$$

$$= 0.0375\text{V}$$

where S is the sensor sensitivity at T1, V_{BDRIVE} is the sensor excitation voltage (initially 2.5V), and ΔP is the maximum pressure differential.

Then calculate the ideal gain using the following formula, and select the nearest gain setting from Table 2:

$$A_{\text{PGA}} = \frac{\text{OUTFSO}}{\text{SensorFSO}}$$

$$= \frac{4\text{V}}{0.0375\text{V}} = 106\text{V/V}$$

where OUTFSO is the desired calibrated transducer full-span output voltage, and SensorFSO is the sensor full-span output voltage at T1.

In this example, a PGA value of 2 (gain of +95V/V) is the best selection.

Determining Input-Referred OFFSET (I_{RO})

The input-referred offset register is used to null any front-end sensor offset errors prior to amplification by the PGA. This reduces the possibility of saturating the PGA and maximizes the useful dynamic range of the PGA (particularly at the higher gain values.)

First, calculate the ideal I_{RO} correction voltage using the following formula, and select the nearest setting from Table 1:

$$I_{\text{ROideal}} = -[O(T1) \times V_{\text{BDRIVE}}(T1)]$$

$$= -(0.012\text{V/V}) \times 2.5\text{V}$$

$$= -30\text{mV}$$

where I_{ROideal} is the exact voltage required to perfectly null the sensor, O(T1) is the sensor offset voltage in V/V at +25°C, and V_{BDRIVE}(T1) is the nominal sensor excitation voltage at +25°C. In this example, 30mV must be subtracted from the amplifier front end to null the sensor perfectly. From Table 1, select an I_{RO} value of 3 to set the I_{RO} DAC to 27mV, which is nearest the ideal value. To subtract this value, set the I_{RO} sign bit to 0. The residual output-referred offset error will be corrected later with the Offset DAC.

Determining OFFTC COEF Initial Value

Generally, OFFTC COEF can initially be set to 0, since the offset TC error will be compensated in a later step. However, sensors with large offset TC errors may require an initial coarse offset TC adjustment to prevent the PGA from saturating during the compensation procedure as temperature is increased. An initial coarse offset TC adjustment is required for sensors with an offset TC greater than about 10% of the FSO. If an initial

1%-Accurate, Digitally Trimmed Sensor Signal Conditioner

coarse offset TC adjustment is required, use the following equation:

$$\begin{aligned} \text{OFFTC COEF} &= \frac{4096 \times \Delta V_{\text{OUT}}(T)}{\Delta V_{\text{BDRIVE}}(T) \times 2.3} \\ &\equiv \frac{4096 \times (\text{OTC} \times \text{FSO}) \times \Delta T}{\text{TCS} \times V_{\text{BDRIVE}} \times 2.3 \times \Delta T} \\ &= \frac{4096 \times (-1000\text{ppm}/^{\circ}\text{C} \times 4\text{V})}{-2100\text{ppm}/^{\circ}\text{C} \times 2.5\text{V} \times 2.3} = 1357 \end{aligned}$$

where OTC is the sensor offset TC error as a ppm/°C of OUTFSO (Table 6), ΔT is the operating temperature range in °C, and OFFTC COEF is the numerical decimal value to be loaded into the DAC. For positive values, set the OFFTC sign bit high; for negative values, set the OFFTC sign bit low. If the absolute value of the OFFTC COEF is larger than 4096, the sensor has a very large offset TC error, which the MAX1458 is unable to completely correct.

FSO Calibration

Perform FSO calibration at room temperature with a full-scale sensor excitation.

- 1) Set FSOTC COEF to 1000.
- 2) At T1, adjust FSO DAC until VBDRIVE is about 2.5V.
- 3) Adjust Offset DAC (and OFFSET sign bit, if needed) until the T1 offset voltage is 0.5V (see *OFFSET Calibration* section).
- 4) Measure the full-span output (measuredVFSO).
- 5) Calculate the ideal bridge voltage, VBIDEAL(T1), using the following equation:

$$V_{\text{BIDEAL}}(T1) = V_{\text{BDRIVE}} \times \left(1 + \frac{\text{desired}V_{\text{FSO}} - \text{measured}V_{\text{FSO}}(T1)}{\text{measured}V_{\text{FSO}}(T1)} \right)$$

Note: If VBIDEAL(T1) is outside the allowable bridge voltage swing of (VSS + 1.3V) to (VDD - 1.3V), readjust the PGA gain setting. If VBIDEAL(T1) is too low, decrease the PGA gain setting by one step and return to Step 2. If VBIDEAL(T1) is too high, increase the PGA gain setting by one step and return to Step 2.

- 6) Set VBIDEAL(T1) by adjusting the FSO DAC.
- 7) Readjust Offset DAC until the offset voltage is 0.5V (see *OFFSET Calibration* section).

Three-Step FSOTC Compensation

Step 1

Use the following procedure to determine FSOTC COEF. Four variables, A–D, will be used.

- 1) Name the existing FSO DAC coefficient “A”.
- 2) Change FSOTC DAC to 3000.
- 3) Adjust FSO DAC until VBDRIVE (T1) is equal to VBIDEAL(T1).
- 4) Name the existing FSO DAC coefficient “B”.
- 5) Readjust the offset voltage (by adjusting the Offset DAC), if required, to 0.5V.

At this point, it is important that no other changes be made to the Offset or Offset TC DACs until the Offset TC Compensation step has been completed.

Step 2

To complete linear FSOTC compensation, take data measurements at a second temperature, T2 (T2 > T1). Perform the following steps:

- 1) Measure the full-span output (measuredVFSO(T2)).
- 2) Calculate VBIDEAL(T2) using the following equation:

$$V_{\text{BIDEAL}}(T2) = V_{\text{BDRIVE}} \times \left(1 + \frac{\text{desired}V_{\text{FSO}} - \text{measured}V_{\text{FSO}}(T2)}{\text{measured}V_{\text{FSO}}(T2)} \right)$$

- 3) Set VBIDEAL(T2) by adjusting the FSO DAC.
- 4) Name the current FSO DAC coefficient “D”.
- 5) Change FSOTC DAC to 1000.
- 6) Adjust FSO DAC until VBDRIVE is equal to VBIDEAL(T2).
- 7) Name the FSO DAC coefficient “C”.

Step 3

Insert the data previously obtained from Steps 1 and 2 into the following equation to compute FSOTC COEF:

$$\text{FSOTC COEF} = \frac{1000(B - D) + 3000(C - A)}{(B - D) + (C - A)}$$

- 1) Load this FSOTC COEF value into the FSOTC DAC.
- 2) Adjust the FSO DAC until VBDRIVE(T2) is equal to VBIDEAL(T2).

This completes both FSO calibration and FSO TC compensation.

1%-Accurate, Digitally Trimmed Sensor Signal Conditioner

Offset TC Compensation

The offset voltage at T1 was previously set to 0.5V; therefore, any variation from this voltage at T2 is an offset TC error. Perform the following steps:

- 1) Measure the offset voltage at T2.
- 2) Use the following equation to compute the correction required:

$$\text{NewOFFTC COEF} = \text{CurrentOFFTC COEF} + \left(\frac{4096 [V_{\text{OFFSET}}(T1) - V_{\text{OFFSET}}(T2)]}{2.3[V_{\text{BDRIVE}}(T1) - V_{\text{BDRIVE}}(T2)]} \right)$$

Note: CurrentOFFTC COEF is the current value stored in the Offset TC DAC. If the Offset TC sign bit (SOTC) is low, this number is negative.

- 3) Load this value into the Offset TC DAC.

- 4) If NewOFFTC COEF is negative, set the SOTC bit low; otherwise, set it high.

Offset TC Compensation is now complete.

OFFSET Calibration

At this point the sensor should still be at temperature T2. The final offset adjustment can be made at T2 or T1 by adjusting the Offset DAC (and optionally the offset sign bit, SOFF) until the output ($V_{\text{OUT(PMIN)}}$) reads 0.5V at zero input pressure. Use the following procedure:

- 1) Set Offset DAC to zero (Offset COEF = 0).
- 2) Measure the voltage at OUT.
- 3) If V_{OUT} is greater than the desired offset voltage (0.5V in this example), set SOFF low; otherwise set it high.
- 4) Increase Offset COEF until V_{OUT} equals the desired offset voltage.

Offset calibration is now complete. Table 8 and Figure 9 compare an uncompensated input to a typical compensated transducer output.

Table 8. MAX1458 Calibration and Compensation

Typical Uncompensated Input (Sensor)	Typical Compensated Transducer Output
Offset±80% FSO	V_{OUT}Ratiometric to V_{DD} at 5.0V
FSO15mV/V	Offset at +25°C0.500V ±5mV
Offset TC-17% FSO	FSO at +25°C4.000V ±5mV
Offset TC Nonlinearity0.7% FSO	Offset Accuracy Over Temp. Range±28mV (±0.7% FSO)
FSO TC-35% FSO	FSO Accuracy Over Temp. Range±20mV (±0.5% FSO)
FSO TC Nonlinearity0.5% FSO	
Temperature Range.....-40°C to +125°C	

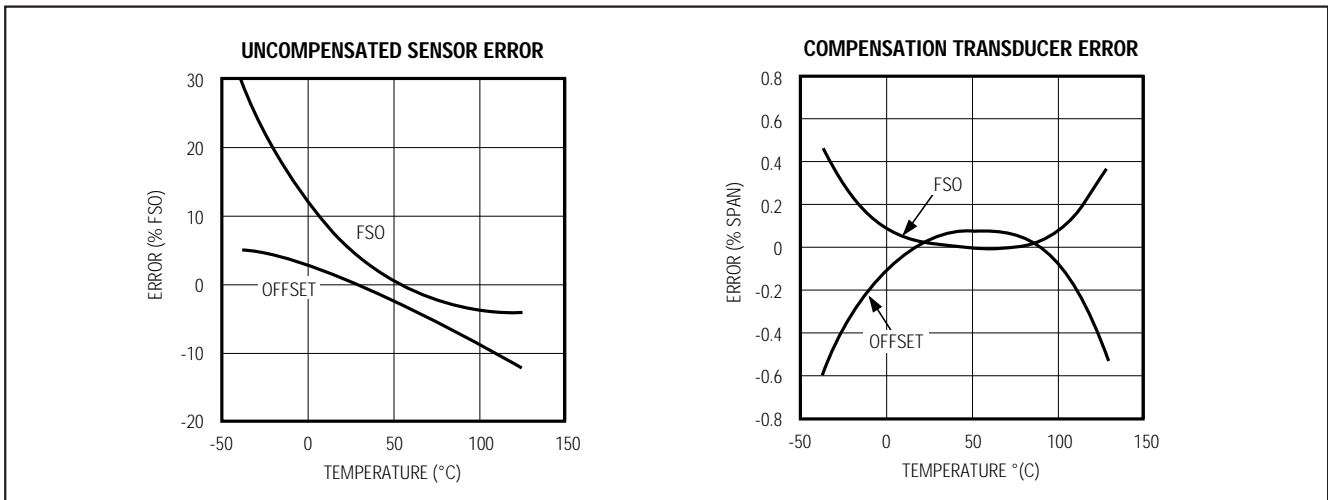

Figure 9. Comparison of an Uncalibrated Sensor and a Temperature-Compensated Transducer

1%-Accurate, Digitally Trimmed Sensor Signal Conditioner

Ratiometric Output Configuration

Ratiometric output configuration provides an output that is proportional to the power-supply voltage. When used with ratiometric A/D converters, this output provides digital pressure values independent of supply voltage. Most automotive and some industrial applications require ratiometric outputs.

The MAX1458 provides a high-performance ratiometric output with a minimum number of external components (Figure 10). These external components include the following:

- One power-supply bypass capacitor (C1)
- Two optional resistors, one from FSOTC to ISRC, and another from ISRC to V_{SS}, depending on the sensor type
- One optional capacitor C2 from BDRIVE to V_{SS}

Test System Configuration

The MAX1458 is designed to support an automated production pressure-temperature test system with integrated calibration and temperature compensation. Figure 11 shows the implementation concept for a low-cost test system capable of testing up to 12 transducer modules connected in parallel. Three-state outputs on the MAX1458 allow for parallel connection of transducers. The test system shown in Figure 11 includes a dedicated test bus consisting of five wires:

- Two power-supply lines
- One analog output voltage line from the transducers to a system digital voltmeter
- Two serial-interface lines: DIO (input/output) and SCLK (clock)

For simultaneous testing of more than 12 sensor modules, use buffers to prevent overloading the data bus. A digital multiplexer controls the chip-select signal for each transducer.

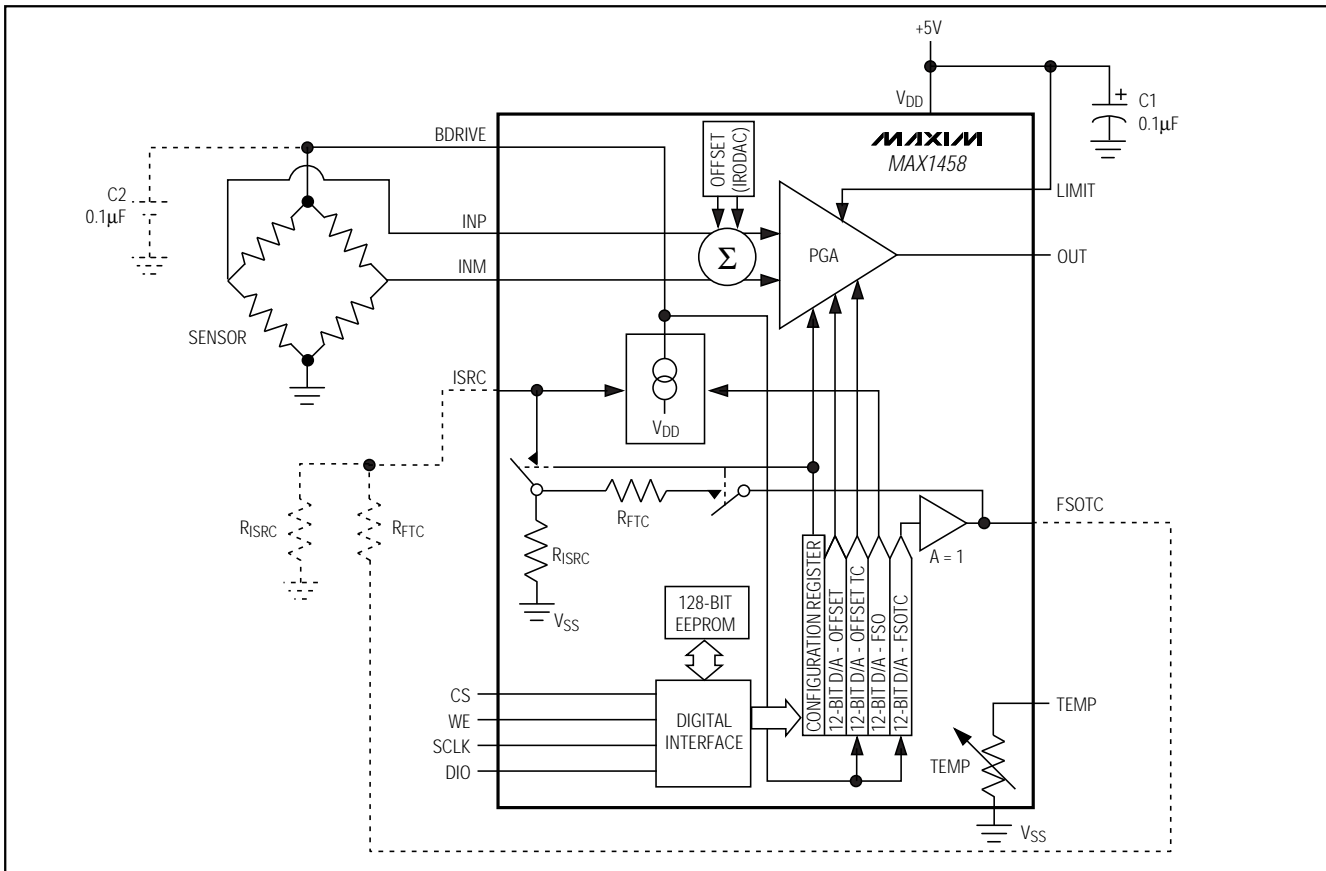

Figure 10. Basic Ratiometric Output Configuration

1%-Accurate, Digitally Trimmed Sensor Signal Conditioner

MAX1458

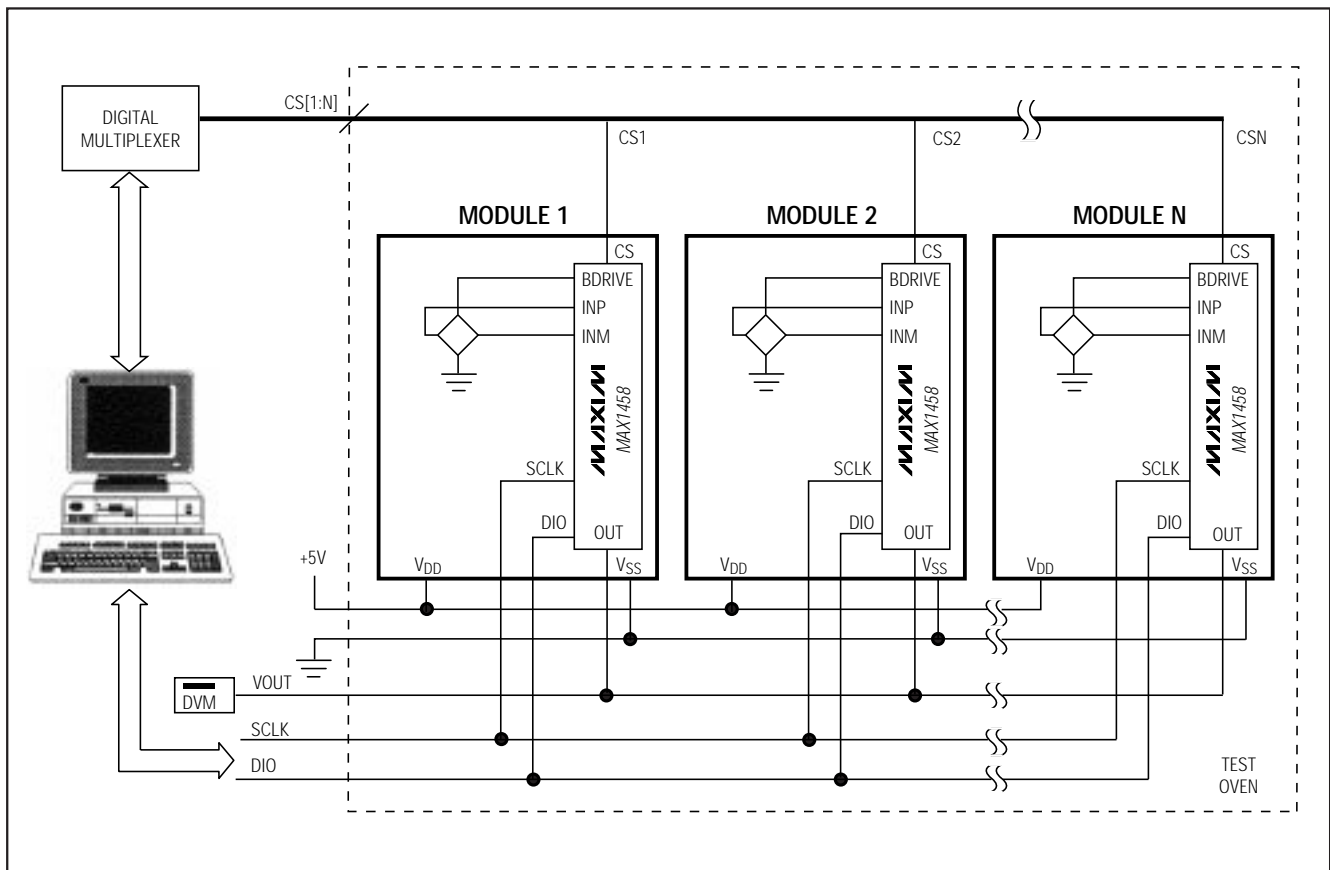

Figure 11. Automated Test System Concept

MAX1458 Evaluation Development Kit

To expedite the development of MAX1458 based transducers and test systems, Maxim has produced the MAX1458 evaluation kit (EV kit). *First-time users of the MAX1458 are strongly encouraged to use this kit.* The MAX1458 EV kit is designed to facilitate manual programming of the MAX1458 and includes the following:

- 1) **Evaluation Board** with a silicon pressure sensor.
- 2) **Design/Applications Manual**, which describes in detail the architecture and functionality of the MAX1458. This manual was developed for test engineers familiar with data acquisition of sensor data and provides sensor compensation algorithms and test procedures.
- 3) **MAX1458 Communication Software**, which enables programming of the MAX1458 from a computer (IBM compatible), one module at a time.
- 4) **Interface Adapter and Cable**, which allow the connection of the evaluation board to a PC parallel port.

1%-Accurate, Digitally Trimmed Sensor Signal Conditioner

MAX1458

Functional Diagram

Chip Information

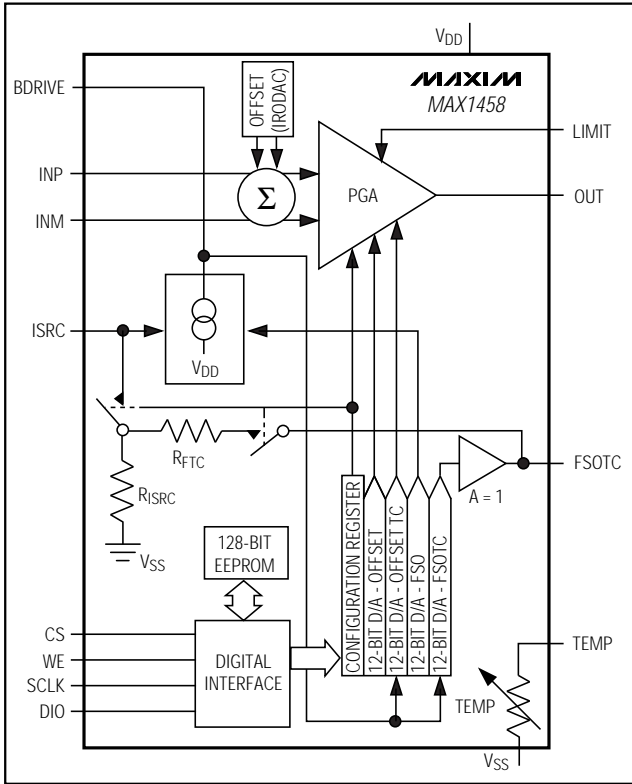

TRANSISTOR COUNT: 7772
SUBSTRATE CONNECTED TO VSS

1%-Accurate, Digitally Trimmed Sensor Signal Conditioner

Package Information

MAX1458

SSOP-EPS

DIM	INCHES		MILLIMETERS	
	MIN	MAX	MIN	MAX
A	0.068	0.078	1.73	1.99
A1	0.002	0.008	0.05	0.21
B	0.010	0.015	0.25	0.38
C	0.004	0.008	0.09	0.20
D	SEE VARIATIONS			
E	0.205	0.209	5.20	5.38
e	0.0256	BSC	0.65	BSC
H	0.301	0.311	7.65	7.90
L	0.025	0.037	0.63	0.95
α	0°	8°	0°	8°

D	INCHES		MILLIMETERS	
	MIN	MAX	MIN	MAX
D	0.239	0.249	6.07	6.33
D	0.239	0.249	6.07	6.33
D	0.278	0.289	7.07	7.33
D	0.317	0.328	8.07	8.33
D	0.397	0.407	10.07	10.33

NOTES:

1. D&E DO NOT INCLUDE MOLD FLASH.
2. MOLD FLASH OR PROTRUSIONS NOT TO EXCEED .15mm (.006")
3. CONTROLLING DIMENSION: MILLIMETER

MAXIM			
PROPRIETARY INFORMATION			
TITLE: PACKAGE OUTLINE, SSOP, 5.3X.65mm			
APPROVAL	DOCUMENT CONTROL NO.	REV	1/1
	21-0056	A	

1%-Accurate, Digitally Trimmed Sensor Signal Conditioner

NOTES

Maxim cannot assume responsibility for use of any circuitry other than circuitry entirely embodied in a Maxim product. No circuit patent licenses are implied. Maxim reserves the right to change the circuitry and specifications without notice at any time.

20 _____ Maxim Integrated Products, 120 San Gabriel Drive, Sunnyvale, CA 94086 408-737-7600

Copyright © Each Manufacturing Company.

All Datasheets cannot be modified without permission.

This datasheet has been download from :

www.AllDataSheet.com

100% Free DataSheet Search Site.

Free Download.

No Register.

Fast Search System.

www.AllDataSheet.com