

MAX828 MAX829

Switched Capacitor Voltage Converters

The MAX828/829 are CMOS “charge-pump” voltage converters in ultra-small SOT-23 5 lead packages. They invert and/or double an input voltage which can range from +1.5V to +5.5V. Conversion efficiency is typically >95%. Switching frequency is 12kHz for the MAX828 and 35kHz for the MAX829.

External component requirement is only two capacitors (3.3µF nominal) for standard voltage inverter applications. With a few additional components a positive doubler can also be built. All other circuitry, including control, oscillator, power MOSFETs are integrated on-chip. Supply current is 50 µA (MAX828) and 115 µA (MAX829).

The MAX828 and MAX829 are available in a SOT-23 5 lead surface mount package.

Features

- Charge Pump in SOT-23 5 Lead Package
- >95% Voltage Conversion Efficiency
- Voltage Inversion and/or Doubling
- Low 50 µA (MAX828) Quiescent Current
- Operates from +1.5V to +5.5V
- Up to 25 mA Output Current
- Only Two External Capacitors Required
- Tested Operating Temperature Range: -40°C to +85°C

Typical Applications

- LCD Panel Bias
- Cellular Phones
- Pagers
- PDAs, Portable Dataloggers
- Battery-Powered Devices

TYPICAL OPERATING CIRCUIT

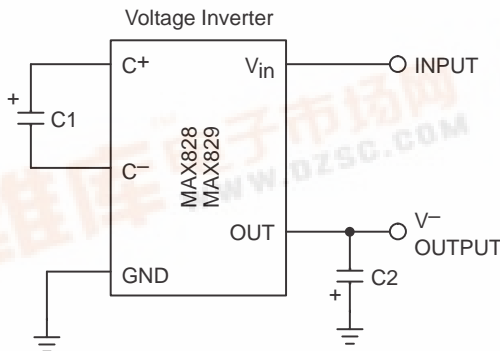

ON Semiconductor
Formerly a Division of Motorola
<http://onsemi.com>

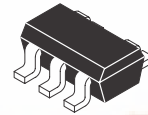

SOT-23-5
SN SUFFIX
CASE TBD
PRELIMINARY INFORMATION

PIN CONFIGURATION (Top View)

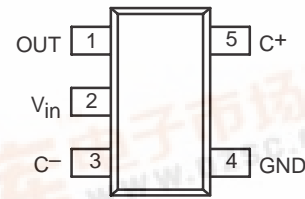

SOT-23-5*

NOTE: *SOT-23-5 is equivalent to EIAJ-SC74A

ORDERING INFORMATION

Device	Package	Shipping
MAX828SNTR	SOT-23-5	3000 Tape/Reel
MAX829SNTR	SOT-23-5	3000 Tape/Reel



MAX828 MAX829

PIN DESCRIPTION

Pin No.	Symbol	Description
1	OUT	Inverting charge pump output
2	V _{IN}	Positive power supply input
3	C ⁻	Commutation capacitor negative terminal
4	GND	Ground
4	C ⁺	Commutation capacitor positive terminal

ABSOLUTE MAXIMUM RATINGS*

Symbol	Parameter	Value	Unit
	Input Voltage (V _{IN} to GND)	+6.0, -0.3	V
	Output Voltage (OUT to GND)	-6.0, +0.3	V
	Current at OUT Pin	50	mA
	Short-Circuit Duration – OUT to GND	Indefinite	
T _A	Operating Temperature Range	-40 to +85	°C
P _D	Power Dissipation (T _A ≤ 70°C) SOT-23-5 Derate by 4mW/°C for T _A > 70°C	240	mW
T _{stg}	Storage Temperature Range	-65 to +150	°C
T _{sol}	Lead Temperature (Soldering, 10 Seconds)	+300	°C

* Maximum Ratings are those values beyond which damage to the device may occur.

ELECTRICAL CHARACTERISTICS (T_A = 0°C to +85°C, V_{IN} = +5V, C1 = C2 = 10μF (MAX828), C1 = C2 = 3.3μF (MAX829), unless otherwise noted. Typical values are at T_A = 25°C.)

Symbol	Characteristic	Min	Typ	Max	Unit
I _{DD}	Supply Current (T _A = 25°C) MAX828 MAX829	— —	50 115	90 260	μA
V ⁺	Supply Voltage Range (R _{LOAD} = 10kΩ)	—	—	5.5	V
F _{OSC}	Oscillator Frequency (T _A = 25°C) MAX828 MAX829	8.4 24.5	12 35	15.6 45.5	kHz
P _{EFF}	Power Efficiency I _{LOAD} = 3mA, T _A = 25°C	—	96	—	%
V _{EFF}	Voltage Conversion Efficiency (R _{LOAD} = ∞)	95	99.9	—	%
R _{OUT}	Output Resistance (Note 1.) I _{OUT} = 5mA, T _A = 25°C T _A = 0°C to +85°C	— —	25 —	50 65	Ω

1. Capacitors C1 and C2 contribution is approximately 20% of the output impedance. For additional information, refer to Equation 1 in the Applications Information section.

ELECTRICAL CHARACTERISTICS (T_A = -40°C to +85°C, V_{IN} = +5V, C1 = C2 = 10μF (MAX828), C1 = C2 = 3.3μF (MAX829), unless otherwise noted. Typical values are at T_A = 25°C.) (Note 2.)

Symbol	Characteristic	Min	Typ	Max	Unit
I _{DD}	Supply Current MAX828 MAX829	— —	— —	115 325	μA
V _{in}	Supply Voltage Range (R _{LOAD} = 10kΩ)	1.5	—	5.5	V
F _{OSC}	Oscillator Frequency MAX828 MAX829	6.0 19	— —	20 54.3	kHz
R _{OUT}	Output Resistance (I _{OUT} = 5mA)	—	—	65	Ω

2. All -40°C to +85°C specifications are guaranteed by design.

MAX828 MAX829

DETAILED OPERATING DESCRIPTION

The MAX828/829 charge pump converters invert the voltage applied to the V_{IN} pin. Conversion consists of a two-phase operation (Figure 1). During the first phase, switches S2 and S4 are open and S1 and S3 are closed. During this time, C1 charges to the voltage on V_{IN} and load current is supplied from C2. During the second phase, S2 and S4 are closed, and S1 and S3 are open. This action connects C1 across C2, restoring charge to C2.

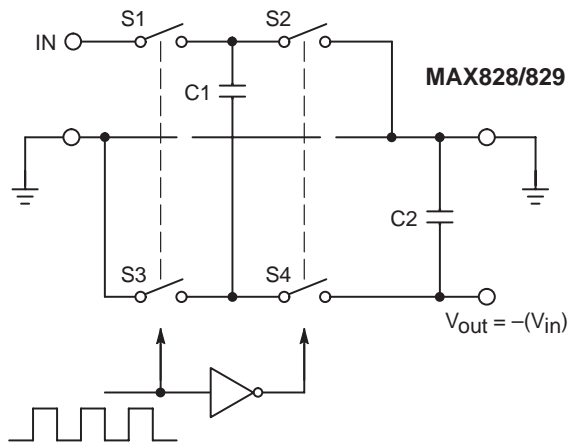

Figure 1. Ideal Switched Capacitor Charge Pump

APPLICATIONS INFORMATION

Output Voltage Considerations

The MAX828/829 perform voltage conversion but do not provide *regulation*. The output voltage will drop in a linear manner with respect to load current. The value of this equivalent output resistance is approximately 25Ω nominal at $+25^\circ\text{C}$ and $V_{IN} = +5\text{V}$. V_{OUT} is approximately -5V at light loads, and droops according to the equation below:

$$V_{\text{DROP}} = I_{\text{OUT}} \times R_{\text{OUT}}$$

$$V_{\text{OUT}} = -(V_{\text{IN}} - V_{\text{DROP}})$$

Charge Pump Efficiency

The overall power efficiency of the charge pump is affected by four factors:

- (1) Losses from power consumed by the internal oscillator, switch drive, etc. (which vary with input voltage, temperature and oscillator frequency).
- (2) I^2R losses due to the on-resistance of the MOSFET switches on-board the charge pump.
- (3) Charge pump capacitor losses due to effective series resistance (ESR).

- (4) Losses that occur during charge transfer (from the commutation capacitor to the output capacitor) when a voltage difference between the two capacitors exists.

Most of the conversion losses are due to factors (2), (3) and (4) above. These losses are given by Equation 1.

$$P_{\text{LOSS}(2,3,4)} = I_{\text{OUT}}^2 \times R_{\text{OUT}} \cong I_{\text{OUT}}^2 \times \left[\frac{1}{(f_{\text{OSC}})C1} + 8R_{\text{SWITCH}} + 4\text{ESR}_{C1} + \text{ESR}_{C2} \right]$$

Equation 1.

The $1/(f_{\text{OSC}})(C1)$ term in Equation 1 is the effective output resistance of an ideal switched capacitor circuit (Figures 2a, 2b).

The losses in the circuit due to factor (4) above are also shown in Equation 2. The output voltage ripple is given by Equation 3.

$$P_{\text{LOSS}(4)} = \left[(0.5)(C1)(V_{\text{IN}}^2 - V_{\text{OUT}}^2) + (0.5)(C2)(V_{\text{RIPPLE}}^2 - 2V_{\text{OUT}}V_{\text{RIPPLE}}) \right] \times f_{\text{OSC}}$$

Equation 2.

$$V_{\text{RIPPLE}} = \frac{I_{\text{OUT}}}{(f_{\text{OSC}})(C2)} + 2(I_{\text{OUT}})(\text{ESR}_{C2})$$

Equation 3.

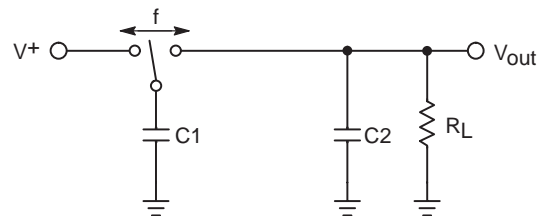

Figure 2a. Ideal Switched Capacitor Model

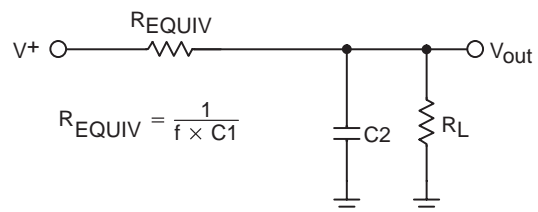

Figure 2b. Equivalent Output Resistance

MAX828 MAX829

Capacitor Selection

In order to maintain the lowest output resistance and output ripple voltage, it is recommended that low ESR capacitors be used. Additionally, larger values of C1 will lower the output resistance and larger values of C2 will reduce output ripple. (See Equation 3).

Table 1 shows various values of C1 and the corresponding output resistance values at +25°C. It assumes a 0.1Ω ESR_{C1} and 0.5Ω R_{SW}. Table 2 shows the output voltage ripple for various values of C2. The V_{RIPPLE} values assume 10mA output load current and 0.1Ω ESR_{C2}.

Table 1. Output Resistance vs. C1 (ESR = 0.1Ω)

C1(μF)	MAX828 R _{OUT} (Ω)	MAX829 R _{OUT} (Ω)
0.1	1.7k	580
1	170	61
3.3	55	21
10	21	10
47	8.0	5.7
100	6.2	5.1

Table 2. Output Voltage Ripple vs. C2 (ESR = 0.1Ω) I_{OUT} = 10mA

C2(μF)	MAX828 V _{RIPPLE} (mV)	MAX829 V _{RIPPLE} (mV)
1	830	290
3.3	250	87
10	83	28
47	17	6.1
100	8.3	2.9

Input Supply Bypassing

The V_{IN} input should be capacitively bypassed to reduce AC impedance and minimize noise effects due to the switching internal to the device. The recommended capacitor depends on the configuration of the MAX828/829.

If the device is loaded from OUT to GND it is recommended that a large value capacitor (at least equal to C1) be connected from the input to GND. If the device is loaded from IN to OUT a small (0.1μF) capacitor from IN to OUT is sufficient.

Voltage Inverter

The most common application for charge pump devices is the inverter (Figure 3). This application uses two external capacitors - C1 and C2 (plus a power supply bypass capacitor, if necessary). The output is equal to -V_{IN} plus any voltage drops due to loading. Refer to Table 1 and Table 2 for capacitor selection.

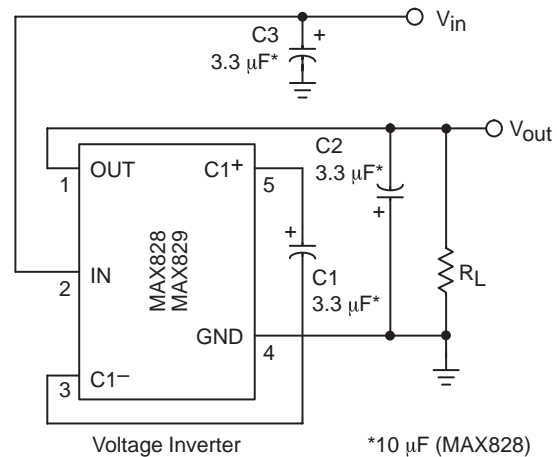

Figure 3. Test Circuit

Cascading Devices

Two or more MAX828/829's can be cascaded to increase output voltage (Figure 4). If the output is lightly loaded, it will be close to (- 2 x V_{IN}) but will droop at least by R_{OUT} of the first device multiplied by the I_Q of the second. It can be seen that the output resistance rises rapidly for multiple cascaded devices.

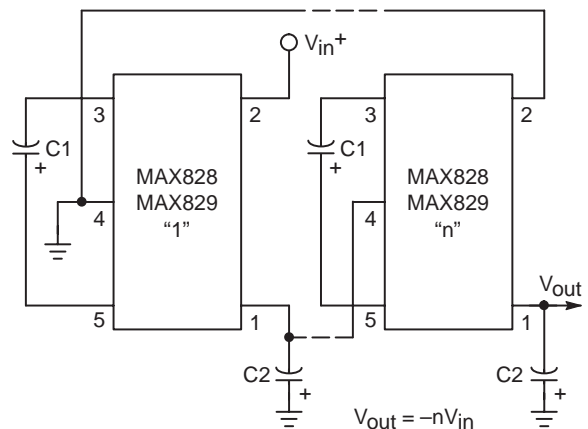

Figure 4. Cascading MAX828s or MAX829s to Increase Output Voltage

Paralleling Devices

To reduce the value of R_{OUT}, multiple MAX828/829s can be connected in parallel (Figure 5). The output resistance will be reduced by a factor of N where N is the number of MAX828/829's. Each device will require its own pump capacitor (C1), but all devices may share one reservoir capacitor (C2). However, to preserve ripple performance the value of C2 should be scaled according to the number of paralleled MAX828/829's.

MAX828 MAX829

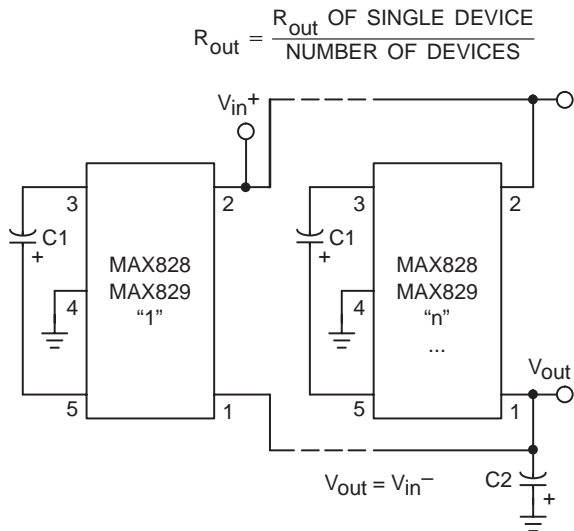

Figure 5. Paralleling MAX828s or MAX829s to Reduce Output Resistance

Voltage Doubler/Inverter

Another common application of the MAX828/829 is shown in Figure 6. This circuit performs two functions in combination. C1 and C2 form the standard inverter circuit described above. C3 and C4 plus the two diodes form the voltage doubler circuit. C1 and C3 are the pump capacitors and C2 and C4 are the reservoir capacitors. Because both sub-circuits rely on the same switches if either output is loaded, both will droop toward GND. Make sure that the total current drawn from both the outputs does not total more than 40mA.

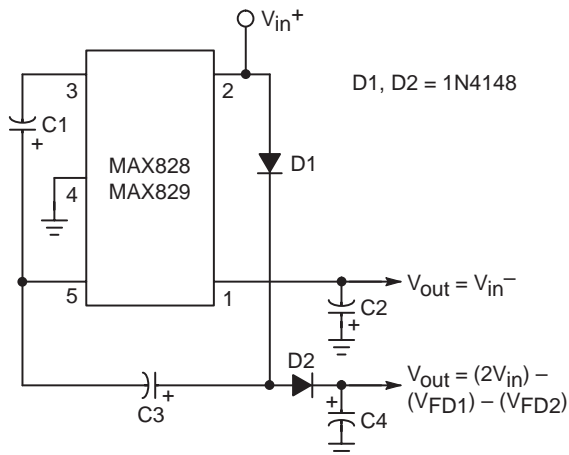

Figure 6. Combined Doubler and Inverter

Diode Protection for Heavy Loads

When heavy loads require the OUT pin to sink large currents being delivered by a positive source, diode protection may be needed. The OUT pin should not be allowed to be pulled above ground. This is accomplished by connecting a Schottky diode (1N5817) as shown in Figure 7.

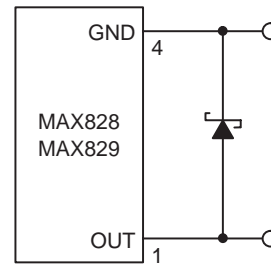

Figure 7. High V⁻ Load Current

Layout Considerations

As with any switching power supply circuit good layout practice is recommended. Mount components as close together as possible to minimize stray inductance and capacitance. Also use a large ground plane to minimize noise leakage into other circuitry.

MAX828 MAX829

TYPICAL CHARACTERISTICS

Circuit of Figure 3, $V_{in} = +5\text{ V}$, $C1 = C2 = C3$, $T_A = +25^\circ\text{C}$, unless otherwise noted.

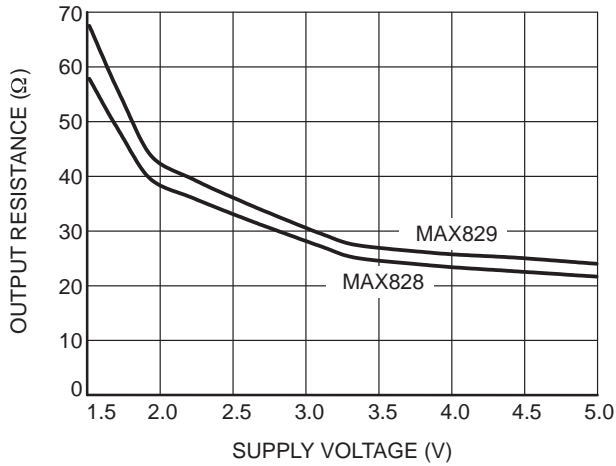

Figure 8. Output Resistance versus Supply Voltage

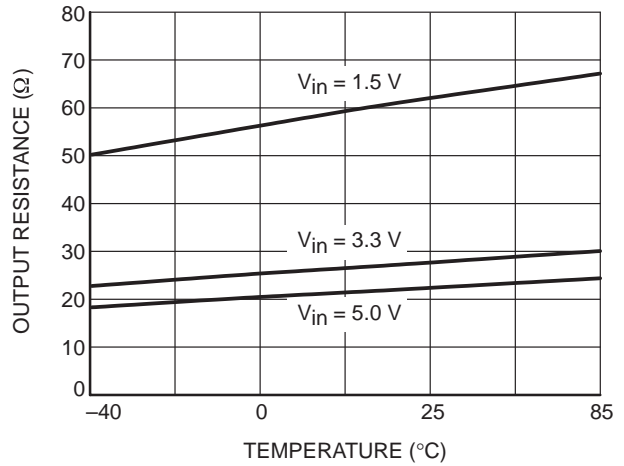

Figure 9. Output Resistance versus Temperature

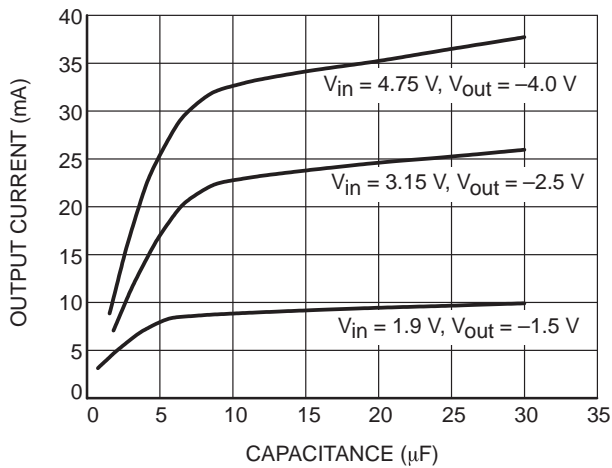

Figure 10. Output Current versus Capacitance (MAX828)

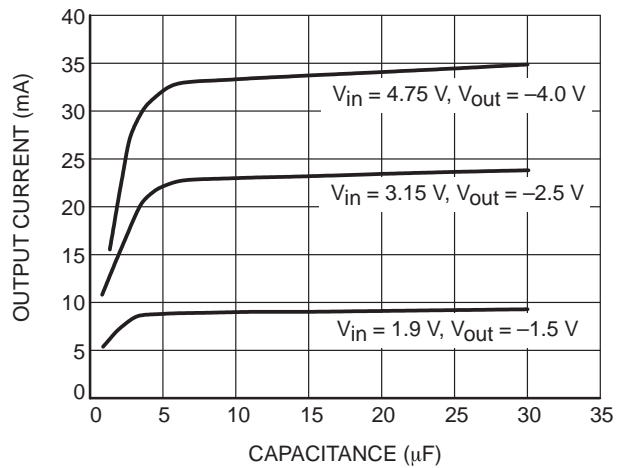

Figure 11. Output Current versus Capacitance (MAX829)

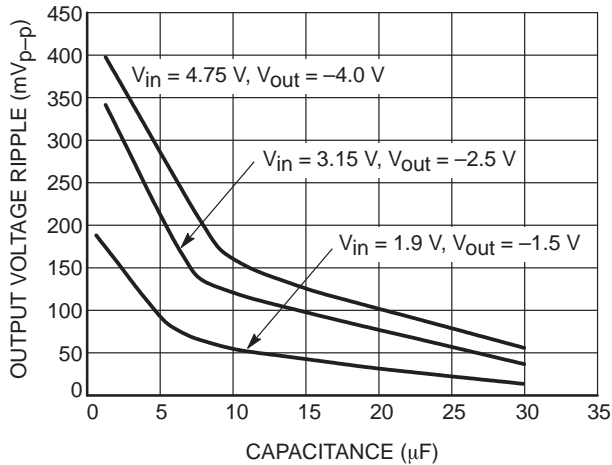

Figure 12. Output Voltage Ripple versus Capacitance (MAX828)

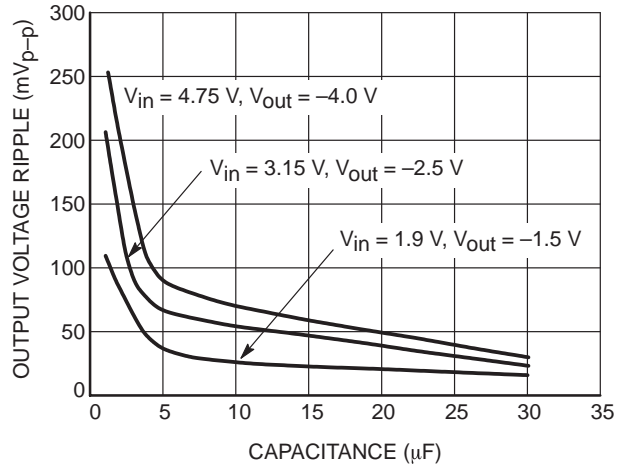

Figure 13. Output Voltage Ripple versus Capacitance (MAX829)

MAX828 MAX829

TYPICAL CHARACTERISTICS

Circuit of Figure 3, $V_{in} = +5\text{ V}$, $C1 = C2 = C3$, $T_A = +25^\circ\text{C}$, unless otherwise noted.

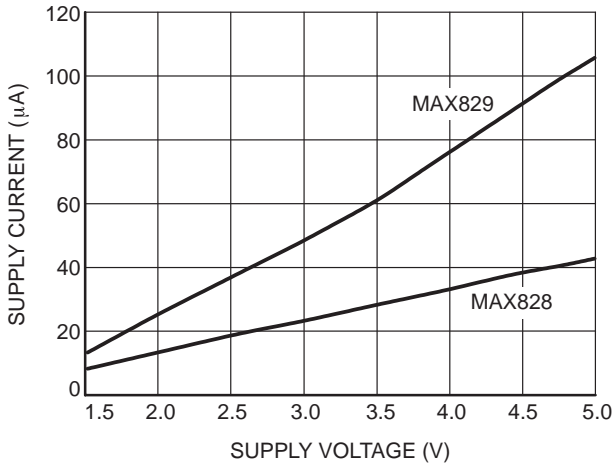

Figure 14. Supply Current versus Supply Voltage

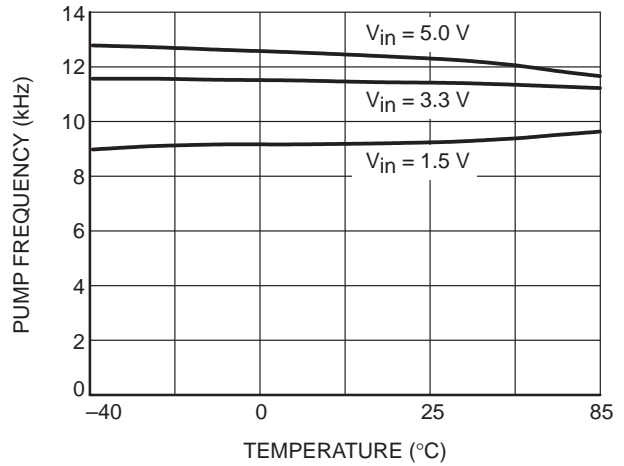

Figure 15. Pump Frequency versus Temperature (MAX828)

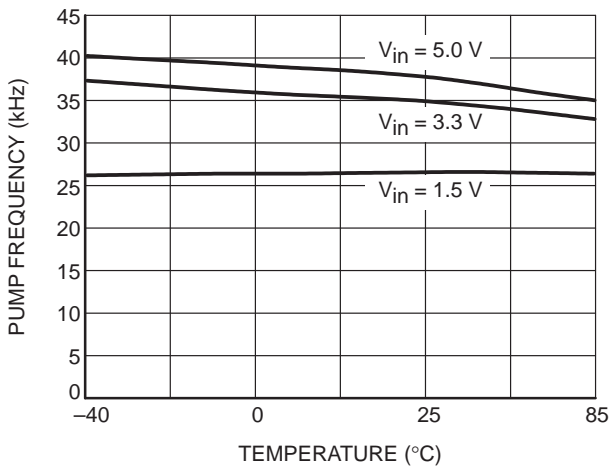

Figure 16. Pump Frequency versus Temperature (MAX829)

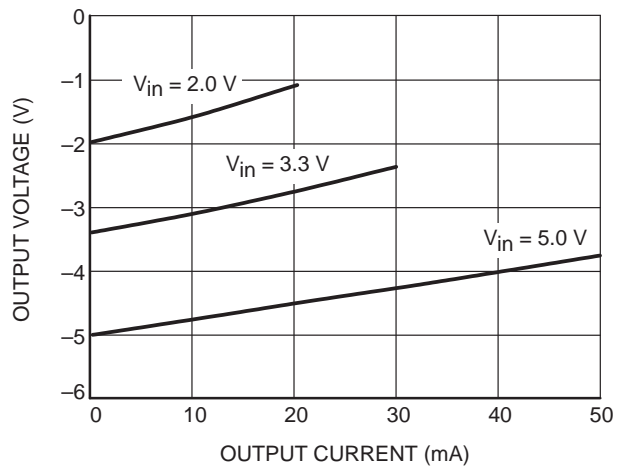

Figure 17. Output Voltage versus Output Current

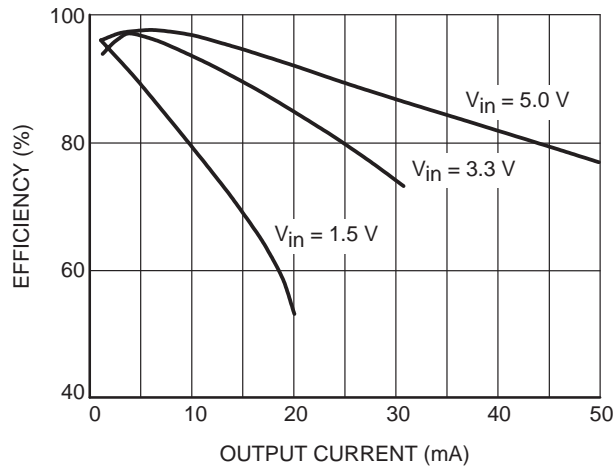
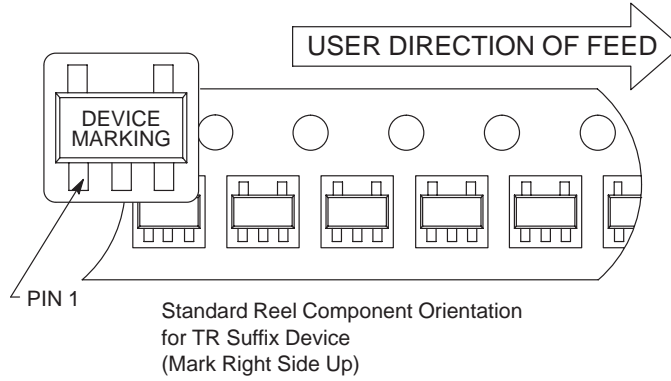

Figure 18. Efficiency versus Output Current

MAX828 MAX829

TAPING FORM

Component Taping Orientation for 5L SOT-23 Devices



Tape & Reel Specifications Table

Package	Tape Width (W)	Pitch (P)	Part Per Full Reel	Diameter
5L SOT-23	8 mm	4 mm	3000	7 inches

MARKING

SOT-23-5

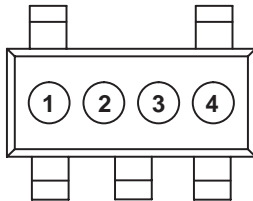

MAX828/829

Marking (1) + (2)

MAX828SNTR
MAX829SNTR

CA
CB

(3) + (4) Date Code

MAX828 MAX829

PACKAGE DIMENSIONS

SOT-23-5
PLASTIC PACKAGE
CASE TBD
ISSUE TBD

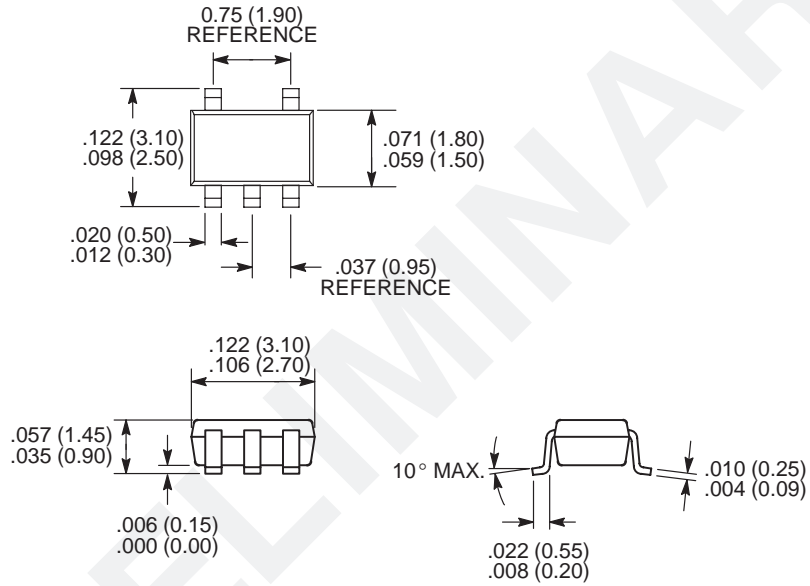

NOTE: SOT-23-5 is equivalent to EIAJ-SC74A

Dimensions: inches (mm)

MAX828 MAX829

Notes

MAX828 MAX829

Notes

MAX828 MAX829

ON Semiconductor and  are trademarks of Semiconductor Components Industries, LLC (SCILLC). SCILLC reserves the right to make changes without further notice to any products herein. SCILLC makes no warranty, representation or guarantee regarding the suitability of its products for any particular purpose, nor does SCILLC assume any liability arising out of the application or use of any product or circuit, and specifically disclaims any and all liability, including without limitation special, consequential or incidental damages. "Typical" parameters which may be provided in SCILLC data sheets and/or specifications can and do vary in different applications and actual performance may vary over time. All operating parameters, including "Typicals" must be validated for each customer application by customer's technical experts. SCILLC does not convey any license under its patent rights nor the rights of others. SCILLC products are not designed, intended, or authorized for use as components in systems intended for surgical implant into the body, or other applications intended to support or sustain life, or for any other application in which the failure of the SCILLC product could create a situation where personal injury or death may occur. Should Buyer purchase or use SCILLC products for any such unintended or unauthorized application, Buyer shall indemnify and hold SCILLC and its officers, employees, subsidiaries, affiliates, and distributors harmless against all claims, costs, damages, and expenses, and reasonable attorney fees arising out of, directly or indirectly, any claim of personal injury or death associated with such unintended or unauthorized use, even if such claim alleges that SCILLC was negligent regarding the design or manufacture of the part. SCILLC is an Equal Opportunity/Affirmative Action Employer.

PUBLICATION ORDERING INFORMATION

NORTH AMERICA Literature Fulfillment:

Literature Distribution Center for ON Semiconductor
P.O. Box 5163, Denver, Colorado 80217 USA
Phone: 303-675-2175 or 800-344-3860 Toll Free USA/Canada
Fax: 303-675-2176 or 800-344-3867 Toll Free USA/Canada
Email: ONlit@hibbertco.com
Fax Response Line: 303-675-2167 or 800-344-3810 Toll Free USA/Canada

N. American Technical Support: 800-282-9855 Toll Free USA/Canada

EUROPE: LDC for ON Semiconductor – European Support

German Phone: (+1) 303-308-7140 (M-F 1:00pm to 5:00pm Munich Time)
Email: ONlit-german@hibbertco.com
French Phone: (+1) 303-308-7141 (M-F 1:00pm to 5:00pm Toulouse Time)
Email: ONlit-french@hibbertco.com
English Phone: (+1) 303-308-7142 (M-F 12:00pm to 5:00pm UK Time)
Email: ONlit@hibbertco.com

EUROPEAN TOLL-FREE ACCESS*: 00-800-4422-3781

*Available from Germany, France, Italy, England, Ireland

CENTRAL/SOUTH AMERICA:

Spanish Phone: 303-308-7143 (Mon-Fri 8:00am to 5:00pm MST)
Email: ONlit-spanish@hibbertco.com

ASIA/PACIFIC: LDC for ON Semiconductor – Asia Support

Phone: 303-675-2121 (Tue-Fri 9:00am to 1:00pm, Hong Kong Time)
Toll Free from Hong Kong & Singapore:
001-800-4422-3781
Email: ONlit-asia@hibbertco.com

JAPAN: ON Semiconductor, Japan Customer Focus Center

4-32-1 Nishi-Gotanda, Shinagawa-ku, Tokyo, Japan 141-8549
Phone: 81-3-5740-2745
Email: r14525@onsemi.com

ON Semiconductor Website: <http://onsemi.com>

For additional information, please contact your local Sales Representative.