

# XE1202

433MHz / 868MHz / 915MHz

## Low-power, integrated UHF transceiver

### GENERAL DESCRIPTION

The XE1202 is a single chip transceiver operating in the 433, 868 and 915MHz license free ISM (Industry Scientific and Medical) frequency bands. Its highly integrated architecture allows for minimum external components while maintaining design flexibility. All major RF communication parameters are programmable and most of them can be dynamically set. The XE1202 offers the unique advantage of narrow-band and wide-band communication, this without the need to modify the number or parameters of the external components. The XE1202 is optimized for low power consumption while offering high RF output power and channelized operation suited for both the European (ETSI-300-220) and the North American (FCC part 15) regulatory standards

### APPLICATIONS

- Narrow-band and wide-band security systems
- Voice and data over an RF link
- Process and building control
- Access control
- Home automation
- Home appliances interconnection

### KEY PRODUCT FEATURES

- Programmable RF output power: up to +15dBm
- High reception sensitivity: down to -113dBm
- Low power consumption: RX=14mA; TX = 48mA @15 dBm output power
- Supply voltage down to 2.7V
- Wide band operation: 400kHz channels for data rates of up to 76.8kbps, NRZ coding
- Narrow band operation: down to 25kHz channels for data rates of 4.8kbps, NRZ coding
- On-chip frequency synthesizer with steps of 500Hz
- Continuous phase 2-level FSK modulation
- Incoming data pattern recognition
- Built-in Bit-Synchronizer for incoming data and clock synchronization and recovery
- RSSI (Received Signal Strength Indicator) and FEI (Frequency Error Indicator)

### ORDERING INFORMATION

Part number	Temperature range	Package
XE1202I027	-40°C to +85°	LQFP44



**Table of Contents**

General Description .....	1
Applications .....	1
Key product features .....	1
Ordering information .....	1
<b>1 Functional Block Diagram .....</b>	<b>3</b>
<b>2 Pin description .....</b>	<b>4</b>
<b>3 Electrical Characteristics .....</b>	<b>5</b>
3.1 Absolute Maximum Operating Ranges .....	5
3.2 Specifications .....	5
3.2.1 Operating Range .....	5
3.2.2 Electrical Specifications .....	5
<b>4 Description .....</b>	<b>7</b>
4.1 Detailed description .....	8
4.1.1 Receiver .....	8
4.1.2 High sensitivity vs. high linearity: A-mode, B-mode .....	8
4.1.3 RSSI .....	8
4.1.4 Frequency Error Indicator - FEI .....	9
4.1.5 Transmitter .....	11
4.1.6 Pattern recognition .....	12
4.1.7 Clock Output for external processor .....	12
<b>5 Interface definition, Principles of operation .....</b>	<b>13</b>
5.1 Serial Control Interface .....	13
5.2 Configuration and Status registers .....	14
5.2.1 RTParam configuration register .....	14
5.2.2 FSParam configuration register .....	15
5.2.3 DataOut register .....	16
5.2.4 ADParam configuration register .....	17
5.2.5 Pattern register .....	18
5.3 Operating Modes .....	19
5.3.1 Standard power up sequence for the receiver and transmitter .....	19
5.3.2 Single step sequence for the receiver .....	21
5.4 Transmitted Data Interface .....	21
5.5 Received Data Interface .....	21
5.6 Pattern Recognition Interface .....	21
5.7 Clock Output Interface .....	22
5.8 Default settings at power-up .....	22
<b>6 Application Information .....</b>	<b>23</b>
6.1 Matching network of the receiver .....	23
6.2 Matching network of the transmitter .....	23
6.3 VCO tank .....	24
6.4 Loop filter of the frequency synthesizer .....	24
6.5 Reference crystal for the frequency synthesizer .....	25
6.6 Decoupling capacitances .....	25
<b>7 Packaging information .....</b>	<b>26</b>

The XE1202 single-chip solution is an integrated circuit intended for use as a low cost FSK transceiver to establish a frequency-agile, half-duplex, bi-directional RF link, with non-return to zero data coding. The device is available in an LQFP44 package and is designed to provide a fully functional multi-channel FSK transceiver. It is intended for applications in the 433- and 868MHz European band and the North American 902-928MHz ISM band. The single chip transceiver operates down to 2.7 V and provides low power consumption solutions for battery-operated and power sensitive applications. Thanks to the low external components count, the XE1202 is ideal for small size, low-cost UHF links. Its reference board design has no tunable components, which facilitates high volume cost sensitive production.

The XE1202 can easily be interfaced to a controller such as the XEMICS' XE8000 Series of ultra low-power microcontrollers. The XE1202 serial control registers are programmed by the MCU and the MCU manages the communication protocol.

## 1 Functional Block Diagram

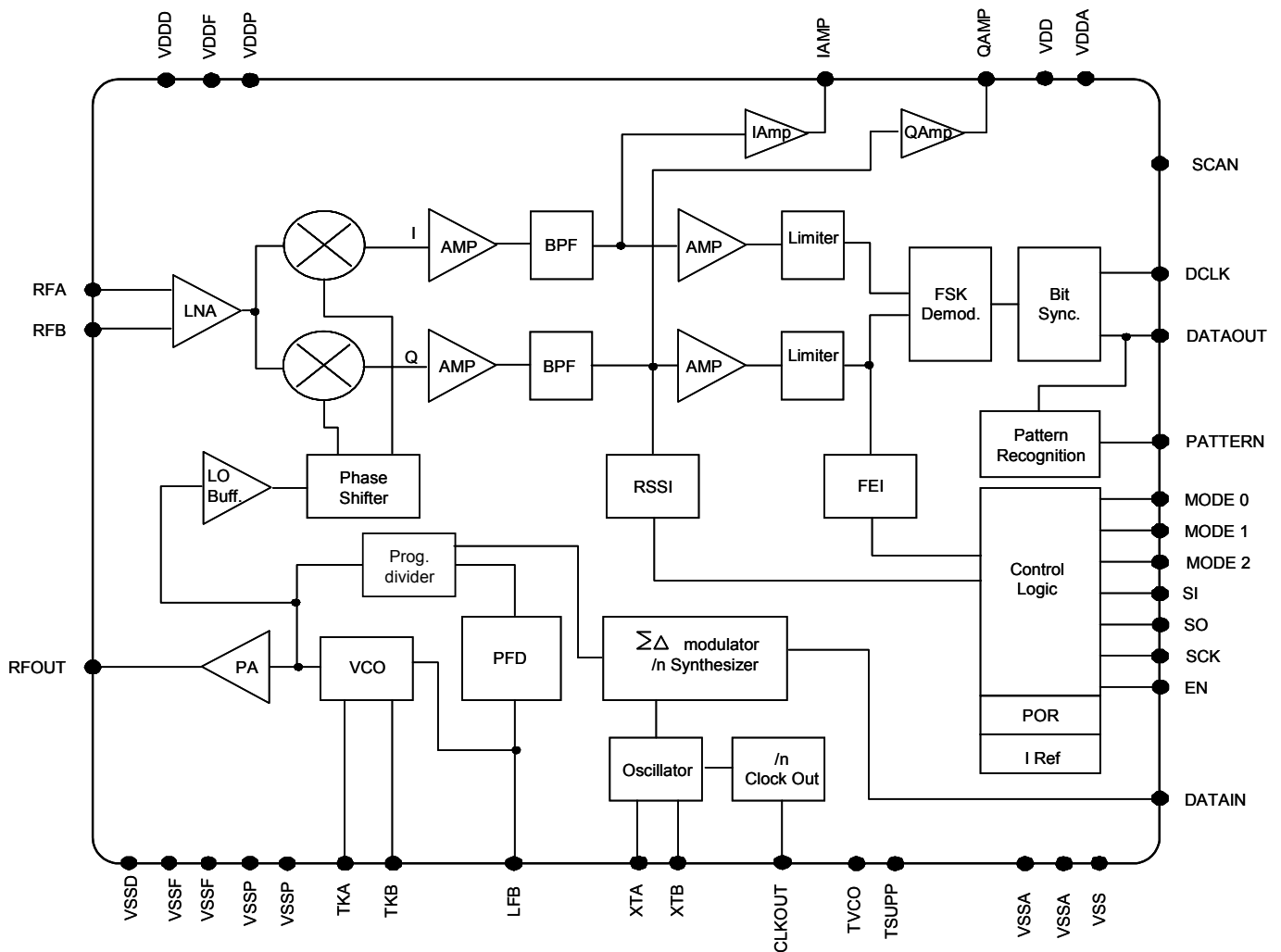

## 2 Pin description

PIN	NAME		DESCRIPTION
1	MODE(1)	In	Transmit/Receive/Stand-by/Sleep Mode Select
2	MODE(0)	In	Transmit/Receive/Stand-by/Sleep Mode Select
3	EN	In	Chip Enable
4	VSSF		HF Analog Ground
5	RFA	In	RF Input
6	RFB	In	RF Input
7	VSSP	In	Power Amplifier Ground
8	VSSP	In	Power Amplifier Ground
9	RFOUT	Out	RF Output
10	VDDP		Power Amplifier Supply Voltage
11	TVCO	In	Test Input (connected to VSS in normal operation)
12	VDD		HF Analog Supply Voltage
13	TKA	I/O	VCO Tank
14	TKB	I/O	VCO Tank
15	VSSF		HF Analog Ground
16	LFB	I/O	PLL Loop Filter
17	VDDD		HF Digital Supply Voltage
18	VSSD		HF Digital Ground
19	TSUPP		Test Circuit Supply Voltage (connected to VSS in normal operation)
20	SCAN	In	Scan Test Input (connected to VSS in normal operation)
21	OPT		(connected to VSS in normal operation)
22	TMOD[0]		(connected to VSS in normal operation)
23	TMOD[1]		(connected to VSS in normal operation)
24	VSSA		LF Analog Ground
25	XTA	I/O	Ref Xtal / Input of external clock
26	VSSA		LF Analog Ground
27	XTB	I/O	Reference Xtal
28	VDDA		LF Analog Supply Voltage
29	QAMP	Out	Output of Q low-pass filter
30	IAMP	Out	Output of I low-pass filter
31	TMOD[2]		(connected to VSS in normal operation)
32	TMOD[3]		(connected to VSS in normal operation)
33	TIBIAS		(connected to VSS in normal operation)
34	VDD		LF Digital Supply Voltage
35	SO	Out	Configuration Register Serial Output
36	SI	In	Configuration Register Serial Input
37	SCK	In	Configuration Register Serial Clock
38	CLKOUT	Out	Output clock at reference frequency divided by 4, 8, 16 or 32
39	VSS		LF Digital Ground
40	DCLK	Out	Recovered Received Data Clock
41	DATAOUT	Out	Received Data
42	DATAIN	In	Transmit Data
43	PATTERN	Out	Output of the pattern recognition block
44	MODE(2)	In	Transmit/Receive/Stand-by/Sleep Mode Select

### 3 Electrical Characteristics

#### 3.1 Absolute Maximum Operating Ranges

Stresses above those values listed below may cause permanent device failure. Exposure to absolute maximum ratings for extended periods may affect device reliability.

Symbol	Description	Min.	Max.	Unit
VDDmr	Supply voltage	-0.5	3.9	V
Tmr	Storage temperature	-55	125	°C

#### 3.2 Specifications

##### 3.2.1 Operating Range

Symbol	Description	Min.	Max.	Unit
VDDop	Supply voltage	2.7	3.6	V
TROp	Temperature	-40	85	°C
CLop	Load capacitance on digital ports	-	25	pF

##### 3.2.2 Electrical Specifications

The table below gives the electrical specifications of the transceiver under the following conditions: Supply Voltage = 3.3 V, temperature = 25 °C, 2-level FSK without pre-filtering,  $f_c = 915$  MHz,  $\Delta f = 5$  kHz, Bit rate = 4.8 kb/s,  $BW_{SSB} = 10$  kHz, BER = 1 % (at the output of the bit synchronizer), matched impedances, environment as defined in section 6, unless otherwise specified.

Symbol	Description	Conditions	Min	Typ	Max	Unit
IDDSL	Supply current in sleep mode		-	0.2	1	µA
IDDST	Supply current in standby mode	Quartz oscillator (39 MHz) running	-	0.85	1.10	mA
IDDR	Supply current in receiver mode		-	14	16.5	mA
IDDT	Supply current in transmitter mode	RFOP = 5 dBm	-	33	40	mA
		RFOP = 15 dBm	-	48	59	mA
RFS	RF sensitivity	3.2.2.1 A-mode	-	-113	-110	dBm
		3.2.2.2 B-mode		-102	-99	dBm
FDA	Frequency deviation	Programmable	-	5	-	kHz
			-	10	-	kHz
			-	20	-	kHz
			-	40	-	kHz
			-	100	-	kHz
CCR	Co-channel rejection		-13	-10	-	dBc
IIP3	Input intercept point (from LNA input to base-band filter output)	funw = $f_{LO} + 50$ kHz and $f_{LO} + 95$ kHz				
		A-mode	-43	-40	-	dBm
		B-mode	-28	-25	-	dBm

Symbol	Description	Conditions	Min	Typ	Max	Unit	
ML	Receiver input level		-	-	-20	dBm	
BW	Base band filter bandwidth	Programmable	-	10	-	kHz	
			-	20	-	kHz	
			-	40	-	kHz	
			-	200	-	kHz	
ACR	Adjacent channel rejection	funw = $f_{LO} + 65$ kHz Pw=-107 dBm, A-mode	45	48	-	dBc	
BR	Bit rate	Programmable	-	4.8	-	kb/s	
			-	9.6	-	kb/s	
			-	19.2	-	kb/s	
			-	38.4	-	kb/s	
			-	76.8	-	kb/s	
RFOP	RF output power	Programmable	RFOP10	-3	0	-	dBm
			RFOP1	+2	+5	-	dBm
			RFOP20	+7	+10	-	dBm
			RFOP2	+12	+15	-	dBm
FR	Synthesizer frequency range	Programmable Each range with its own external components	433	-	435	MHz	
			868	-	870	MHz	
			902	-	928	MHz	
TS_BBR	Receiver BB processing wake-up time (first step)	From quartz oscillator running	-	200	250	$\mu$ s	
TS_TR	Transmitter wake-up time	From frequency synthesizer running	-	100	150	$\mu$ s	
TS_BB0	Receiver RF Front-End wake-up time	From frequency synthesizer running "RTPParam_WBB" = 1	-	3.5	4.5	ms	
TS_FS	Frequency synthesizer wake- up time	From quartz oscillator running	-	200	250	$\mu$ s	
TS_BB2	Receiver RF Front-End wake-up time	From frequency synthesizer running RTPParam_WBB=0	-	500	600	$\mu$ s	
TS_FSW	Frequency synthesizer switching time	Between 2 channels at 1 MHz from each other		100	150	$\mu$ s	
TS_RS	RSSI wake-up time	From whole receiver running in mode 100	-	-	1.5	ms	
TS_OS	Quartz oscillator wake-up time		-	-	2	ms	
TS_FE	FEI wake-up time (RTPParam_Fsel = 1) or counting duration (RTPParam_Fsel = 0)	From receiver running RTPParam_Fsel = 1 RTPParam_Fsel = 0	-	-	20/BR	ms	
			-	-	4/BR	ms	
XTAL	Quartz oscillator frequency		-	39	-	MHz	
FSTEP	Frequency synthesizer step		-	500	-	Hz	

Symbol	Description	Conditions	Min	Typ	Max	Unit
VTHR	Equivalent input thresholds of the RSSI	A-mode,low range:VTHR1	-	-105	-	dBm
		VTHR2	-	-100	-	dBm
		VTHR3	-	-95	-	dBm
		A-mode,high range:VTHR1	-	-90	-	dBm
		VTHR2	-	-85	-	dBm
		VTHR3	-	-80	-	dBm
FERR	Error threshold for the FEI	Pw=-100 dBm, A-mode RTParam_Fsel = 1	-	0.5	-	-
SPR	Spurious emission in receiver mode		-	-55	-50	dBm
VIH	Digital input level high	in % VDD	75	-	-	%
VIL	Digital input level low	in % VDD	-	-	25	%
VOH	Digital output level high	in % VDD	75	-	-	%
VOL	Digital output level low	in % VDD	-	-	25	%

## 4 Description

The XE1202 is a direct conversion (0-IF) half-duplex data transceiver. It includes a receiver, a transmitter, a frequency synthesizer and some service blocks. The circuit operates in 3 frequency ranges (433MHz, 868MHz, 915MHz) and uses 2-level FSK modulation.

In a typical application, the XE1202 is programmed by a microcontroller through the 3-wire serial bus SI, SO, SCK to write to and read from the configuration registers.

The circuit consists of 4 main functional blocks:

**The receiver** converts the incoming 2-level FSK modulated signal into a synchronized bit stream. The receiver is composed of a low-noise amplifier, down-conversion mixers, baseband filters, baseband amplifiers, limiters, demodulator and the bit synchronizer. The bit synchronizer transforms the data output of the demodulator into a glitch-free bit stream DATAOUT and generates a synchronized clock DCLK to be used to easily sample the DATAOUT signal without loading an external processor with heavy signal processing. In addition, the receiver includes a Received Signal Strength Indicator function (RSSI), a Frequency Error Indicator function (FEI) that gives indication about the frequency error of the local oscillator, and pattern recognition function to detect programmable reference word in the incoming bit stream. The bandwidth of the base-band filters, the frequency deviation of the expected incoming FSK signal as well as the bitrate of this bit stream are programmable.

**The transmitter** performs the modulation of the carrier by an input bit stream and the transmission of the modulated signal. The modulation is made directly through the frequency synthesizer. An on-chip power amplifier then amplifies the signal. The output power is programmable among 4 possible values. The frequency deviation and the bit rate for the transmit signal are the same as those programmed for the receiver section.

**The frequency synthesizer** generates the local oscillator (LO) signal for the receiver section as well as the FSK modulated signal for the transmitter section. The core of the synthesizer is implemented with a PLL structure. The frequency is programmable with a step of 500 Hz in 3 frequency bands, 433-, 868-, and 915-MHz. This section includes a crystal oscillator whose signal is the reference for the PLL. This reference frequency is divided by 4, 8, 16, or 32 and is made available at the CLKOUT pin to serve as a clock signal for an external processor.

**The control block** generates the control signals according to the setting in its set of configuration registers.

**The service block** performs all the necessary functions for the circuit to work properly, including the internal voltage and current sources.

## 4.1 Detailed description

### 4.1.1 Receiver

The outputs of the receiver are the two signals DATAOUT and DCLK. When the bit “RTParam\_Bits” is “1” (see the Configuration register section below), the bit synchronizer is turned on, and the two output signals are respectively the output NRZ bit stream and the sampling clock. The function of the bit synchronizer is to remove the glitches from the bit stream DATAOUT and to provide the output clock DCLK. The value of DATAOUT is valid at the rising edge of DCLK.

For proper behavior of the bit synchronizer, three conditions must be satisfied:

- the received data must start with a preamble of 24 bits for synchronization; this preamble must be a sequence of “0” and “1” sent alternatively,
- after that, the incoming bit stream must have at least one transition from “0” to “1” or from “1” to “0” every 8 bits,
- the accuracy of the bit rate must be better than  $\pm 5\%$  (assuming the reference Xtal oscillator is exactly 39 MHz)

When “RTParam\_Bits” is “0”, the bit synchronizer is turned off, and the signal DATAOUT is the output of the demodulator. In this case DCLK is not used and its value is set to “low”.

The condition on the modulation index for proper behavior of the demodulator is:

$$\beta = \frac{2 \cdot \Delta f}{BR} \geq 2,$$

where  $\Delta f$  is the frequency deviation and BR the bit rate.

### 4.1.2 High sensitivity vs. high linearity: A-mode, B-mode

The receiver can be operated in two different modes that provide the highest sensitivity or the highest linearity. This is programmable with the register “RTParam\_Rmode” (see the Configuration register section below).

- A-mode: the receiver has the highest sensitivity (see RFS parameter)
- B-mode: the receiver has the highest linearity (see IIP3 parameter)

### 4.1.3 RSSI

When activated, this function provides a Received Signal Strength Indication based on the signal at the output of the base-band filter. To activate this function, the bit “RTParam\_RSSI” (see the Configuration register section below) must be set “1”. When activated, the status is a 2-bits data stored in register “DataOut\_RSSI”, which can be read through the serial control interface. The meaning of this status information is given in the table below, where  $V_{\text{RFFIL}}$  is the differential amplitude of the equivalent input RF signal when the receiver is operated in A-mode. The thresholds  $V_{\text{THR}i}$  are the thresholds at the output of the base-band filter divided by the gain between the input of the receiver and this output.

DataOut_RSSI	Description
0 0	$V_{\text{RFFIL}} \leq V_{\text{THR}1}$
0 1	$V_{\text{THR}1} < V_{\text{RFFIL}} \leq V_{\text{THR}2}$
1 0	$V_{\text{THR}2} < V_{\text{RFFIL}} \leq V_{\text{THR}3}$
1 1	$V_{\text{THR}3} < V_{\text{RFFIL}}$

Table 1 RSSI status description

Two ranges with three  $V_{\text{THR}i}$  are defined and selected with the flag “RTParam\_RSSR”.

The time diagram of an RSSI measurement is given in the next figure. When the RSSI function has been activated the signal strength is periodically measured and the result is stored in the register “DataOut\_RSSI” at each rising edge of the DATAIN. TS\_RS is the wake-up time required after the function has been activated to get a valid result.



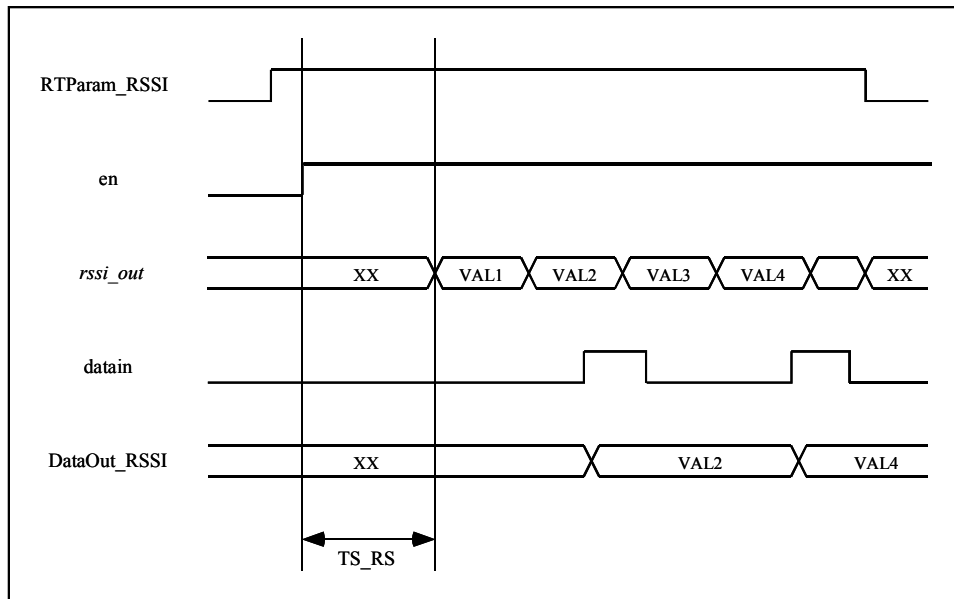

Figure 1 RSSI measurement timing diagram

For applications where the time needed to get the first right result from the RSSI has to be as low as possible, this time can be minimized by waking up the RSSI during mode 010 instead of 100 which is the condition for the definition of TS\_RS in page 6 (for definition of modes, see pages 19 and 20).

#### 4.1.4 Frequency Error Indicator - FEI

When activated, this function provides information about the frequency error of the local oscillator compared with the input carrier frequency. The condition on the modulation index for proper behavior of the FEI function is:

$$\beta = \frac{2 \cdot \Delta f}{BR} \geq 2,$$

where  $\Delta f$  is the frequency deviation and BR is the bit rate.

There are 2 modes of operation for this function selected by the bit "RTParam\_Fsel" (see the Configuration register section below).

#### IMPORTANT NOTE

To guarantee proper behavior of the FEI, the sum of frequency offset and the signal bandwidth (ssb) should be lower than the baseband filter bandwidth (single sided). That is

$$f_{\text{offset}} + \text{SignalBW} < \text{Baseband\_filterBW}$$

where  $f_{\text{offset}}$  is the difference between the carrier frequency and the LO frequency, SignalBW is the signal bandwidth (single sided) equal to the sum of the bitrate divided by 2 and the frequency deviation (Bitrate/2 + Frequency Deviation), and Baseband\_filterBW is the channel filter bandwidth defined by the RTParam\_BW parameter (see the Configuration Registers section below).

##### 4.1.4.1 "RTParam\_Fsel" = 1

To activate the FEI function, the bit "RTParam\_FEI" must be set to "1". When activated, the function provides a 2-bits status stored in register "DataOut\_FEI". The meaning of this output is given in the following table, where  $f_{LO}$  is the internal local oscillator frequency, and  $f_{RF}$  is the carrier frequency of the received signal.

DataOut_FEI	Meaning
0 0	$ f_{LO} - f_{RF}  \leq f_{ERR}$
0 1	-
1 0	$(f_{LO} - f_{RF}) > f_{ERR}$
1 1	$(f_{LO} - f_{RF}) < -f_{ERR}$

Table 2 FEI status description

The threshold  $f_{ERR} = FERR * BR$ , where BR is the bit rate and FERR is a ratio given in the electrical specifications. As an example, for a bit rate of 4.8 kb/s and with  $FERR = 0.5$ ,  $f_{ERR}$  is 2.4 kHz.

This FEI function works properly only if the input signal is the preamble defined under the Receiver section above and if the frequency error to be detected is lower than 20 kHz.

The time diagram of an FEI measurement is quite similar to the one of an RSSI measurement, and is given in the figure below. When the FEI is activated the frequency error is periodically measured and the result is stored in the register "DataOut\_FEI" at each rising edge of DATAIN.  $TS_{FE}$  is the wake-up time required after the function has been activated to get a valid result.

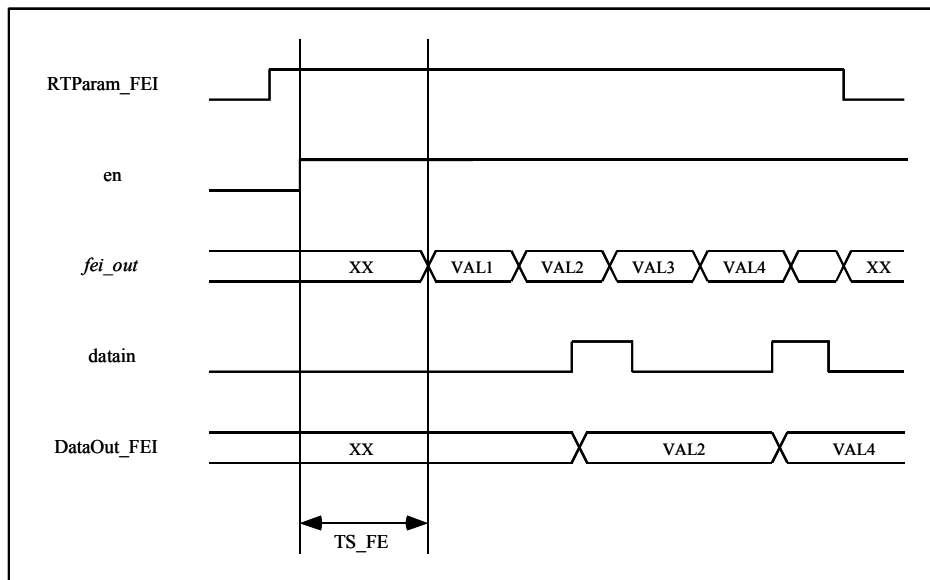

Figure 2 FEI measurement time diagram,  $RTParam\_Fsel = 1$

#### 4.1.4.2 "RTParam\_Fsel" = 0

To activate the FEI function, the bit "RTParam\_FEI" must be set to "1". When activated by the rising edge of DATAIN, the function provides an 8-bits status stored in register "DataOut\_FEI". The timing diagram of this FEI measurement is described in the in figure below. The FEI function is activated at the rising edge of the EN signal when the RTParam\_FEI bit is set to "1". Then, an internal FEI counter is activated at the rising edge of DATAIN. After duration  $TS_{FE}$  (see Electrical Specifications), the counter is stopped and its content is stored in the register DataOut\_FEI. The maximum delay between the rising edge of DATAIN and the first clock on the internal FEI counter is  $1/(16*BR)$ , where BR is the bit rate.

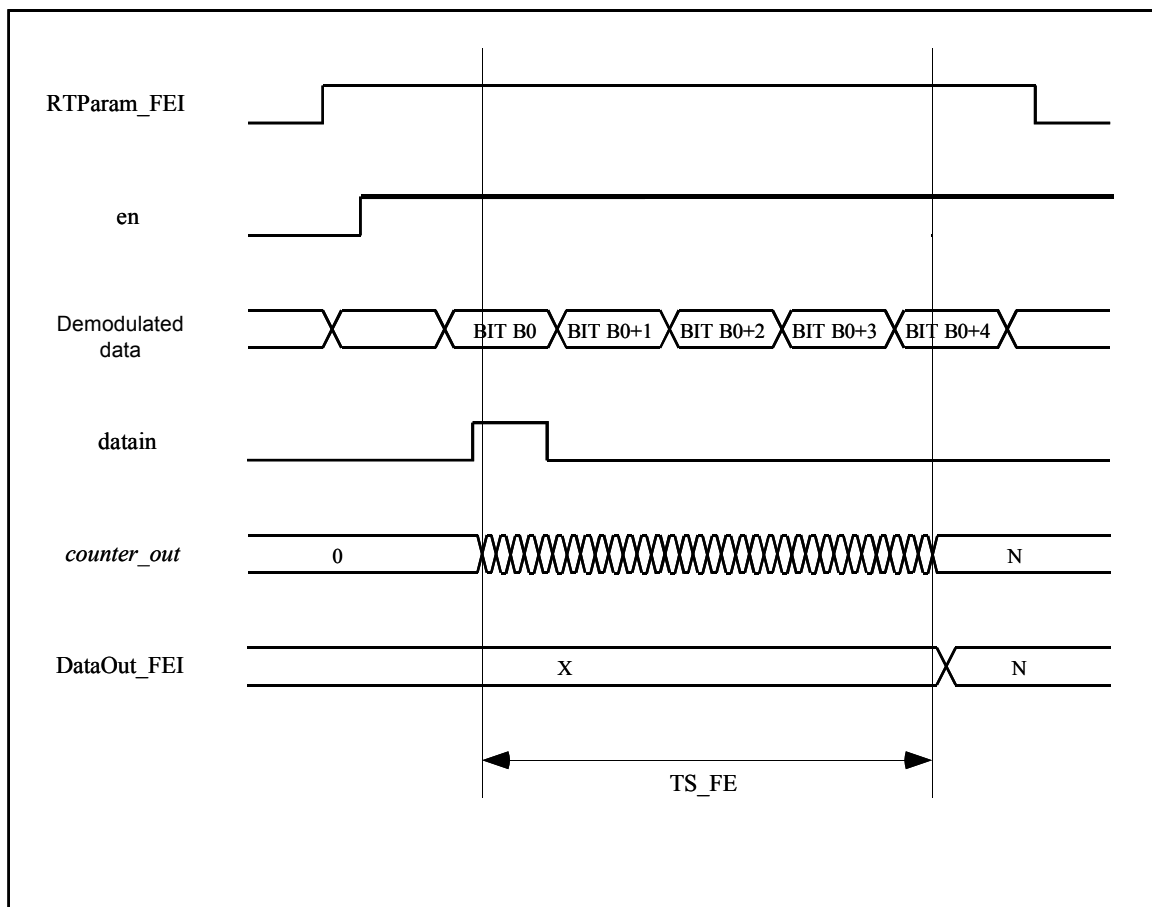

Figure 3 Time diagram of an FEI measurement when “RTParam\_Fsel” = 0  
(the number of transitions on “counter\_out” is for illustration only)

#### 4.1.5 Transmitter

The output power of the power amplifier is programmable on four values with the register “RTParam\_Tpow” (see the Configuration register section below), as shown in the table below, where RFOPi are given in Electrical Specifications section

RTParam_Tpow	Output power
0 0	RFOP10
0 1	RFOP1
1 0	RFOP20
1 1	RFOP2

The type of modulation of the LO frequency by the modulating bit stream is programmable through RTParam\_Filter:

- the input bit stream is directly applied to the frequency synthesizer without any pre-filtering (RTParam\_Filter=0)
- the input bit stream is pre-filtered before being applied to the frequency synthesizer; with this filtering, each edge of the bit stream is linearly smoothed with a staircase transition (RTParam\_Filter=1)

This is illustrated on the next page where DATAIN is the input bit stream to be transmitted.

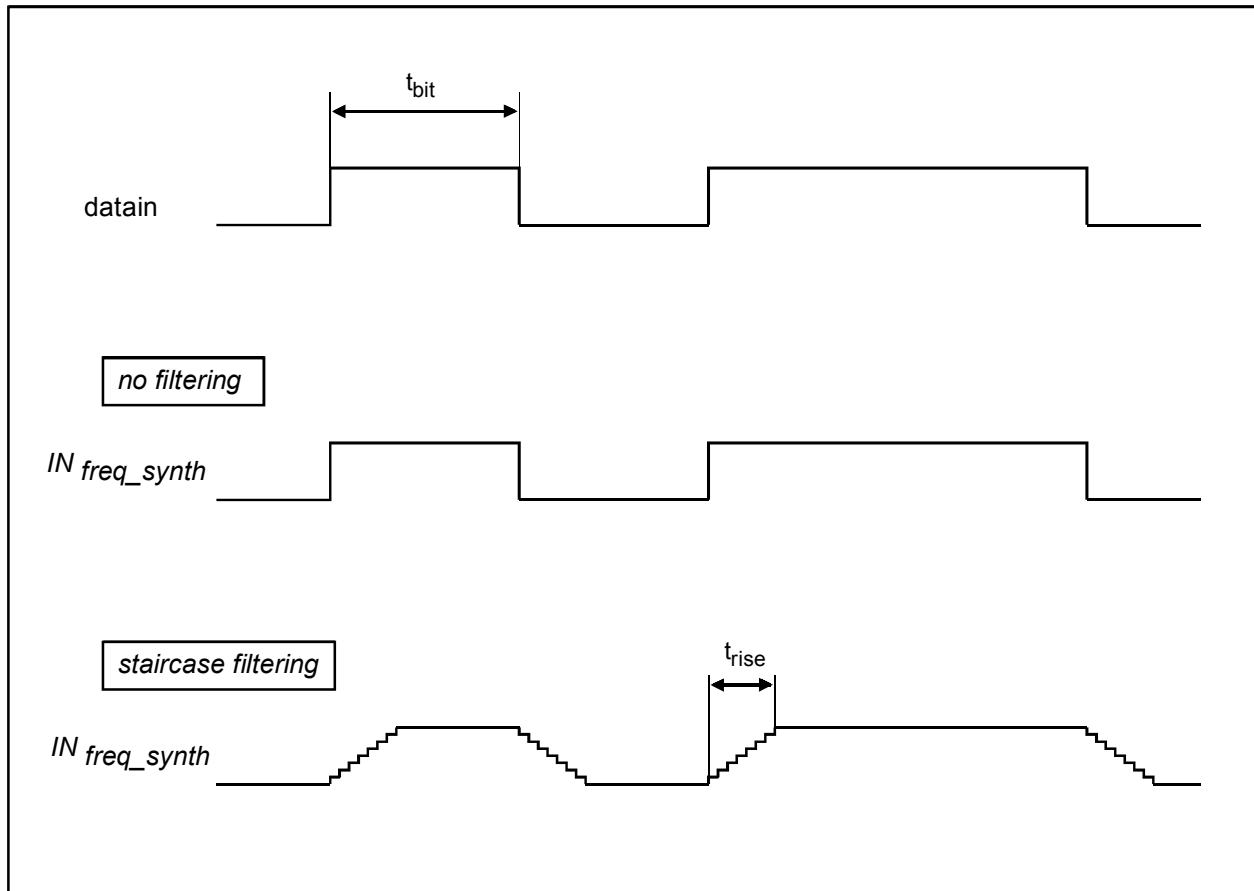

Figure 4 Modulation without and with pre-filtering

The characteristic of the smoothing filter is the ratio  $t_{rise}/t_{bit}$ . The value of this ratio is programmable with the register "RTParam\_Stair", as shown in the following table.

FSParam_Stair	$t_{rise}/t_{bit}$
0	10 %
1	20 %

#### 4.1.6 Pattern recognition

XE1202 includes a pattern recognition function. When "ADParam\_Pattern" (see the Configuration register section below) is set to "1" this feature is turned on, provided the bit synchronizer is turned on too (the pattern recognition feature doesn't work if the bit synchronizer is turned off). In this case, the incoming NRZ bit stream is compared with a pattern stored in the "Pattern" register. The length of this pattern can be 8, 16, 24, or 32 bits, as defined by "ADParam\_Psize". When comparing the streams 0, 1, 2, or 3 errors, as defined by "ADParam\_Psize" can be allowed to detect a match. The PATTERN output is driven by the output of this comparator. It is "high" when a match is detected, otherwise "low".

When the feature is disabled, the PATTERN output is set to "low"

#### 4.1.7 Clock Output for external processor

When "RTParam\_Clkout" is set high, a frequency divider by 4, 8, 16, or 32, depending on "ADParam\_Clkfreq" (see the Configuration register section below), is embedded in XE1202 and provides the CLKOUT clock signal for an MCU or an external circuitry. The input frequency is the 39.0 MHz reference frequency, so the possible clocks available on CLKOUT are 1.22, 2.44, 4.87, or 9.75 MHz. When the XE1202 is in Sleep Mode (MODE[2:0] = 000), this clock is stopped.

## 5 Interface definition, Principles of operation

### 5.1 Serial Control Interface

A 3-wire bi-directional bus (SCK, SI, SO) is used to program the XE1202 and read data from it. SCK and SI are input signals, for example generated by a microcontroller. SO is an output signal controlled by the XE1202. In write mode, at the falling edge of the SCK signal, the logic data on the SI line is written into an internal shift register. In read mode, at the rising edge of the SCK signal, the data on the SO line become valid and should be sampled at the next falling edge of SCK.

The signal EN must be low during the whole write and read sequences. In write mode the actual content of the configuration register is updated at the rising edge of the EN signal. Before this, the new data is stored in temporary registers whose content does not affect the transceiver settings.

The time diagram of a write sequence is given in the figure below. The sequence is initiated when a Start condition is detected, that is when the SI signal is set to “0” during a period of SCK. The next bit is a read/write (R/W) bit which should be “0” to indicate a write operation. The next 5 bits are the address of the control register A[4:0] to be accessed, MSB first. Then, the next 8 bits are the data to be written in the register. The sequence ends with 2 stop bits set to “1”. The data on SI should change at the rising edges of SCK, and are sampled at the falling edge of SCK. After the 2 stop bits, the data transfer is terminated, even if the SI line stays at “1”. After this the SI line should be at “1” for at least one clock cycle on SCK before a new write or read sequence can start. In doing this, users can write multiple registers in raw, there is no need to raise the EN signal in between. The duty cycle of SCK must be between 40 % and 60 % and the maximum frequency of this signal is 1 MHz. Over the operating supply and temperature range, set-up and hold time for SI on the falling edge of SCK are 200ns.

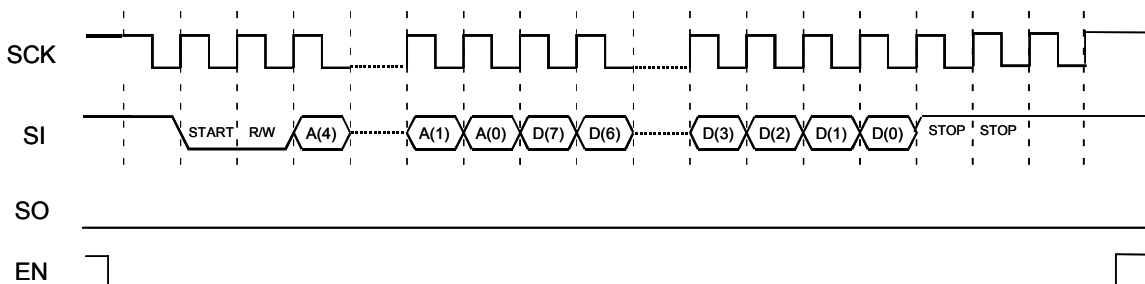

Figure 5 Write sequence into configuration register

The time diagram of a read sequence is given in figure below. The sequence is initiated when a Start condition is detected, that is when the SI signal is set to “0” during a period of SCK. The next bit is a read/write (R/W) bit which should be “1” to indicate a read operation. The next 5 bits are the address of the control register A[4:0] to be accessed, MSB first. Then the data from the register are transmitted on the SO pin. The data become valid at the rising edges of SCK and should be sampled at the falling edge of SCK. After this the data transfer is terminated. The SI line must stay high for at least one clock cycle on SCK to start a new write or read sequence. The maximum current drive on SO is 2mA @ 2.7V, the maximum load is C<sub>Lop</sub>.

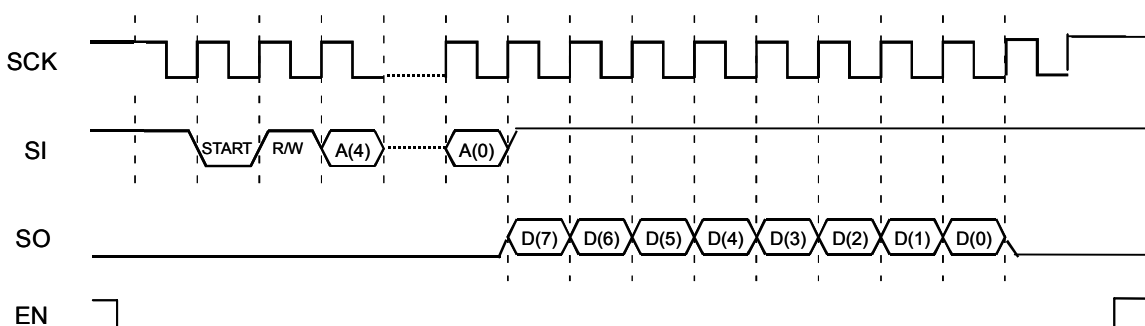

Figure 6 Read sequence into configuration register

When the serial interface is not used for read or write operations, both SCK and SI should be set to “1”. Except in read mode, SO is set to “0”.

## 5.2 Configuration and Status registers

XE1202 has a series of configuration registers programmable through the serial control interface described above. Their name, size, address and description are listed in the table below. The size of these registers is 1, 2, 3, or 4 bytes. Their byte address is 5 bit address, A[4:0]. In addition, there is one register, DataOut, from which users can read various transceiver status information.

Name	Size	Byte Address	Description
RTParam	2 x 8 bit	00000 00001	Receiver and transmitter parameters registers
FSParam	3 x 8 bit	00010 00011 00100	Frequency parameters
DataOut	1 x 8 bit	00101	Transceiver data register
ADParam	2 x 8 bit	00110 00 111	Additional parameters
Pattern	4 x 8 bit	01000 01001 01010 01011	Reference pattern for the “pattern recognition” function

In addition, 16 bytes at addresses A[4:0] = 10000 to 11111 are reserved for test purpose

Name	Size	Byte Address	Description
Test	16 x 8 bit	10000 to 11111	Test registers (reserved)

All the bits that are referred as “reserved” in this section should be set to “0”.

### 5.2.1 RTParam configuration register

Name	Bits	Byte Address	Description
RTParam_Rmode	7	00000	Receiver modes: 0 -> A-mode (high sensitivity) 1 -> B-mode (high linearity)
RTParam_Bits	6	00000	Bit synchronizer on/off: 0 -> off; 1 -> on
RTParam_RSSI	5	00000	RSSI on/off: 0 -> off; 1 -> on
RTParam_FEI	4	00000	FEI on/off: 0 -> off; 1 -> on
RTParam_BW	3-2	00000	Bandwidth of the BB filter: 0 0 -> 10 kHz 0 1 -> 20 kHz 1 0 -> 40 kHz 1 1 -> 200 kHz

Name	Bits	Byte Address	Description
RTParam_Tpow	1-0	00000	Transmitter output power: 0 0 -> 0 dBm 0 1 -> 5 dBm 1 0 -> 10 dBm 1 1 -> 15 dBm
RTParam_Osc	7	00001	Source for the reference frequency: 0 -> on-chip crystal oscillator 1 -> external signal
RTParam_WBB	6	00001	Receiver wake-up type selection 0 -> "Boost" power up sequence 1 -> Standard power-up sequence
RTParam_Filter	5	00001	Pre-filtering of bit stream in transmitter mode: 0 -> no filtering; 1 -> filtering
RTParam_Fsel	4	00001	Selection of the FEI block: 0 -> FEI uses FFD demodulator 1 -> FEI uses correlators
RTParam_Stair	3	00001	Rise and fall time when RTParam_Filter = 1: 0 -> 10 % of bit duration 1 -> 20 % of bit duration
RTParam_Modul	2	00001	Inhibition of the modulation in transmitter mode: 0 -> modulation; 1 -> no modulation
RTParam_RSSR	1	00001	Range of the RSSI: 0 -> low range; 1 -> high range
RTParam_Clkout	0	00001	Enable CLKOUT output: 0 -> no signal on pad CLKOUT 1 -> clock signal available on CLKOUT at 9.75 down to 1.22 MHz (39MHz divided by 4, 8, 16 or 32)

### 5.2.2 FSParam configuration register

Name	Bits	Byte Address	Description
FSParam_Band	7-6	00010	Frequency band: 0 0 -> not valid 0 1 -> 433 – 435 MHz 1 0 -> 868 – 870 MHz 1 1 -> 902 – 928 MHz
FSParam_Dev	5-3	00010	Frequency deviation: 0 0 0 -> 5 kHz 0 0 1 -> 10 kHz 0 1 0 -> 20 kHz 0 1 1 -> 40 kHz 1 0 0 -> 100 kHz

Name	Bits	Byte Address	Description
FSParam_BR	2-0	00010	Bit rate: 0 0 0 -> 4.8 kb/s 0 0 1 -> 9.6 kb/s 0 1 0 -> 19.2 kb/s 0 1 1 -> 38.4 kb/s 1 0 0 -> 76.8 kb/s others -> not valid
FSParam_Freq	7-0 7-0	00011 00100	LO frequency in 2's-complement representation: 00...0 -> $f_{LO}$ = middle of the range 0X...X -> $f_{LO}$ = higher than the middle of the range 1X...X -> $f_{LO}$ = lower than the middle of the range MSB = bit 7 of byte at pos. 00011 LSB = bit 0 of byte at pos. 00100 See example below

Example of LO frequency setting in FSParam\_Freq

Byte Address 00011 Bit 7      Bit 0	Byte Address 00100 Bit 7      Bit 0	Resulting LO setting Note: reference frequency = 39.0 MHz
00000000	00000000	$F_0$ , where $F_0$ depends on the selected frequency band (see FSParam_Band ) $F_0 = 434.0$ MHz for the 433-435 MHz band $F_0 = 869.0$ MHz for the 868-870 MHz band $F_0 = 915.0$ MHz for the 902-928 MHz band
00000000	00000001	$F_0 + 500$ Hz
00000000	00000010	$F_0 + 2 * 500$ Hz
11111111	11111111	$F_0 - 500$ Hz
11111111	11111110	$F_0 - 2 * 500$ Hz

### 5.2.3 DataOut register

Name	Bits	Byte Address	Description
DataOut_RSSI	7-6	00101	RSSI output: 0 0 -> lowest level 0 1 -> 2 <sup>nd</sup> level 1 0 -> 3 <sup>rd</sup> level 1 1 -> highest level
DataOut_FEI When RTParam_Fsel = 0	7-0	00101	FEI output: Output of the up/down counter in 2's-complement representation MSB = bit 7





Name	Bits	Byte Address	Description
DataOut_FEI When RTParam_Fsel = 1	5-4	00101	FEI output: 0 0 -> frequency OK 1 0 -> frequency too low 1 1 -> frequency too high

#### 5.2.4 ADParam configuration register

Name	Bits	Byte Address	Description
ADParam_Pattern	7	00110	Pattern recognition on/off: 0 -> off 1 -> on
ADParam_Psize	6-5	00110	Size of the reference for pattern recognition: 0 0 -> 8 bits 0 1 -> 16 bits 1 0 -> 24 bits 1 1 -> 32 bits
ADParam_Ptol	4-3	00110	Number of tolerated errors for the pattern recognition: 0 0 -> 0 error 0 1 -> 1 error 1 0 -> 2 errors 1 1 -> 3 errors
ADParam_Clkfreq	2-1	00110	Frequency on CLKOUT: 0 0 -> 1.22 MHz (div. ratio: 32) 0 1 -> 2.44 MHz (div. ratio: 16) 1 0 -> 4.87 MHz (div. ratio: 8) 1 1 -> 9.75 MHz (div. ratio: 4)
ADParam_IQA	0	00110	IQ amplifiers on/off: 0 -> off 1 -> on
ADParam_Res1	7	00111	Reserved. Should be set to "0"
ADParam_Invert	6	00111	Inversion of the output data of the receiver: 0 -> non-inverted data 1 -> inverted data
ADParam_RegBW	5	00111	Regulation of the bandwidth of the base-band filter on/off: 0 -> on 1 -> off
ADParam_Regfreq	4	00111	Periodicity of regulation of the bandwidth of the base-band filter: 0 -> only at start-up of the receiver 1 -> each 1 minute as long as the receiver is on

Name	Bits	Byte Address	Description
ADParam_Regcond	3	00111	Regulation process of the bandwidth of the base-band filter according to the selected bandwidth: 0 -> regulation restarted each time the bandwidth is changed 1 -> no regulation started when bandwidth is changed
ADParam_WBBcond	2	00111	Boosting process of the base-band filter according to the selected bandwidth: 0 -> boosting restarted each time the bandwidth is changed 1 -> no boosting started when bandwidth is changed
ADParam_Xsel	1	00111	Selection of the XOSC modes: 0 -> CL + C0 = 15 pF 1 -> CL + C0 = 11 pF, lower current consumption mode
ADParam_Res2	0	00111	Reserved

### 5.2.5 Pattern register

In this register, users can store a reference pattern of 8, 16, 24, or 32 bits (see ADParam\_Psize parameter). The first byte of this pattern is always stored in the byte at address A[4:0] = 01000. If used, the 2<sup>nd</sup> byte is stored at address A[4:0] = 01001, and so on. The MSB bit of the reference pattern is always the bit 7 of the address 01000 and the LSB bit is the bit 0 of the address 01000, 01001, 01010, or 01011 if the pattern length is 8, resp. 16, 24, or 32 bits. When compared to the demodulated bit stream, the last bit received is compared to the LSB bit in the Pattern register. The “oldest” bit received (the first of the last 8, 16, 24, or 32 received bits, depending on ADParam\_Psize) is compared with the bit 7 of byte address 01000 (the MSB).

Name	Bits	Byte Address	Description
Pattern	7-0	01000 01001 01010 01011	1 <sup>st</sup> byte of the reference pattern 2 <sup>nd</sup> byte 3 <sup>rd</sup> byte 4 <sup>th</sup> byte

Example of pattern recognition with a 32-bit pattern

Byte Address 01000 Bit 7      Bit 0	Byte Address 01001 Bit 7      Bit 0	Byte Address 01010 Bit 7      Bit 0	Byte Address 01011 Bit 7      Bit 0
10010011	10101010	10010011	10101010
101 10010011	10101010	10010011	10101010
previous bits from demodulator			last bit received

Example of pattern recognition with an 8-bit pattern

Byte Address 01000 Bit 7      Bit 0	Byte Address 01001 Bit 7      Bit 0	Byte Address 01010 Bit 7      Bit 0	Byte Address 01011 Bit 7      Bit 0
10010011	xxxxxxxx	xxxxxxxx	xxxxxxxx
101 10010011 ←			
previous bits from demodulator	last bit received		

### 5.3 Operating Modes

The XE1202 has 4 main operating modes as set by the MODE[2:0] inputs and illustrated in table below. To switch between modes, the new value of the inputs MODE[2:0] should be modified when the EN signal is low. The actual change will be applied to the transceiver upon the rising edge of the EN signal.

Over the operating supply and temperature range, set-up and hold time for MODE[2:0] on the rising edge of EN are 200ns, while the negative pulse duration on EN is 2µs minimum.

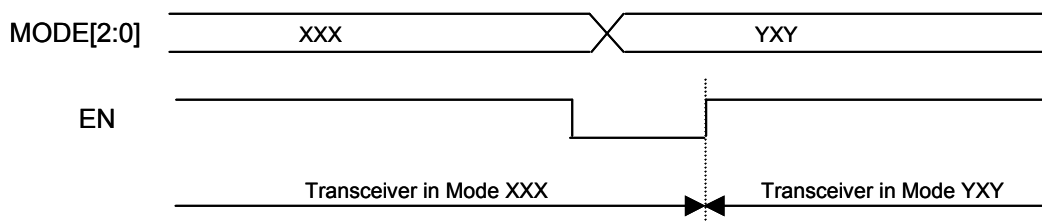

Name	MODE(2:0)	Description
Sleep mode	0 0 0	-
Standby mode	0 0 1	Reference Xtal oscillator running
Receiver mode	1 0 0	Ref Xtal oscillator, Frequency synthesizer, Receiver running
Transmitter mode	1 1 1	Ref Xtal oscillator, Frequency synthesizer, Transmitter running

Table 3 XE1202 Main operating modes

#### 5.3.1 Standard power up sequence for the receiver and transmitter

3 additional operating modes are defined and should be used when the transceiver is switched from the standby mode to the receiver or transmitter mode. These additional operating modes are illustrated in Table 4 below

Name	MODE(2:0)	Description
Receiver mode	0 1 0	Ref Xtal oscillator, Baseband running (first step)
	0 1 1	Ref Xtal oscillator, Frequency synthesizer, Baseband running (first step)
Transmitter mode	1 1 0	Ref Xtal oscillator, Frequency synthesizer running

Table 4 XE1202 Additional operating modes

The standard power up sequence from sleep to receiver mode uses a “boost” procedure; this “boost” sequence is selected by setting the RTParam\_WBB parameter to “0”. The sequence is described in Figure 7 below

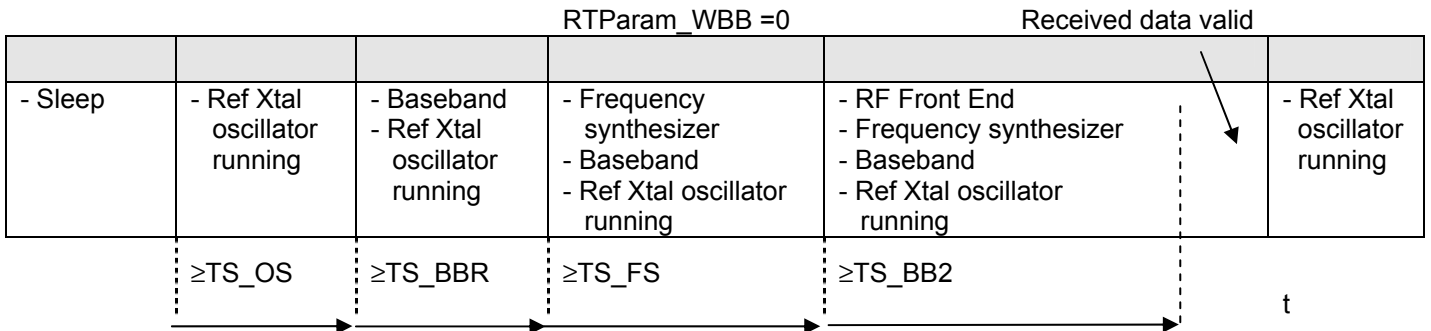

Figure 7 Standard “boosted” power up sequence from Stand By to Receiver Mode

The typical current consumption values during the standard power-up sequence from Stand-by to Receiver Mode is the following

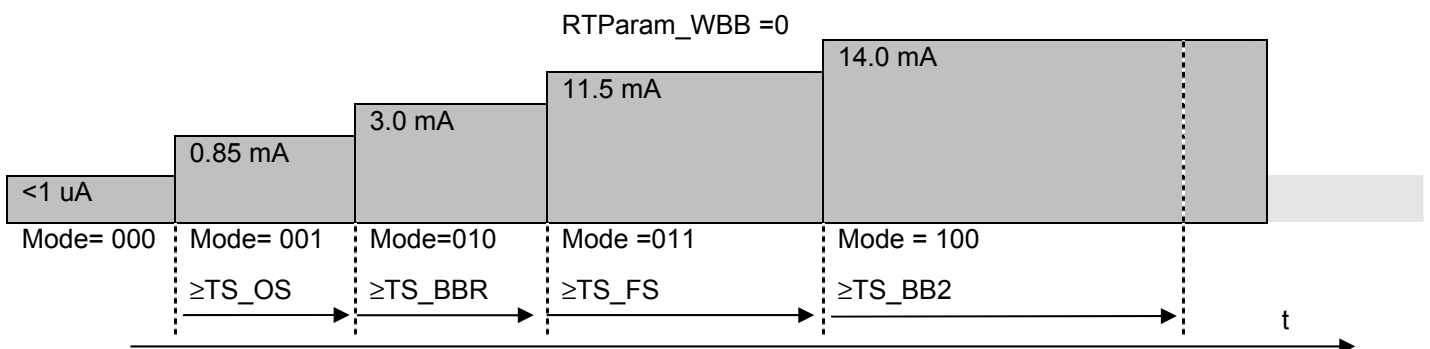

Figure 8 Typical current consumption profile during a standard “boosted” power up sequence from Stand By to Receiver Mode

The standard power up sequence from sleep to transmit mode is described in Figure 9 below

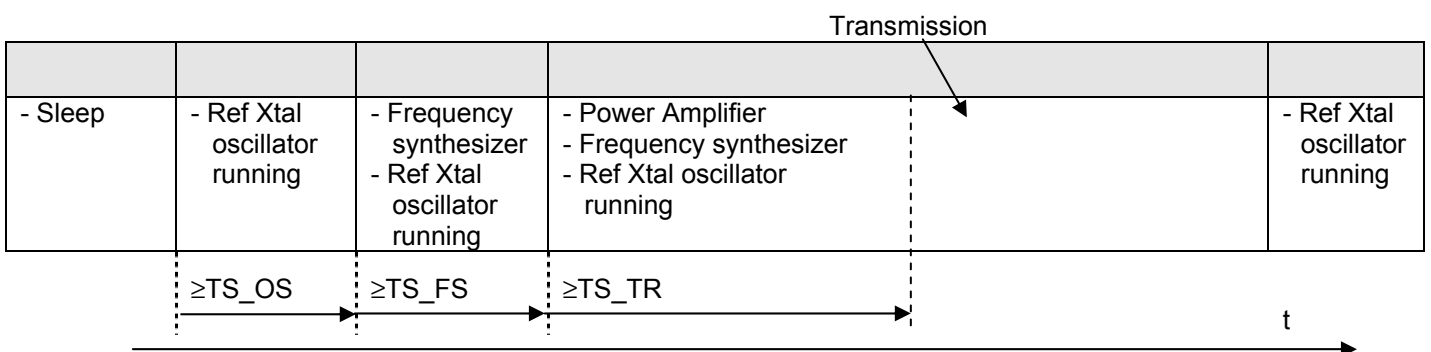

Figure 9 Standard power up sequence from Stand by to Transmit Mode

### 5.3.2 Single step sequence for the receiver

By programming RTParam\_WBB to “1”, the boost procedure is inhibited. In this case, the wake-up time is longer (TS\_BB2 is replaced by TS\_BB0 whose value is given in the electrical specifications).

## 5.4 Transmitted Data Interface

When in transmit mode (MODE[2:0] = 111), the DATAIN signal is used as input for the on-chip modulator. DATAIN is not sampled, so the bit duration should match the bit rate setting of the receiver. Whenever XE1202 are used on both sides of the communication link, the bit rate should be one of those defined in the specifications table (BR). In this case the bit rate error should be less than 5% compared to the specified value.

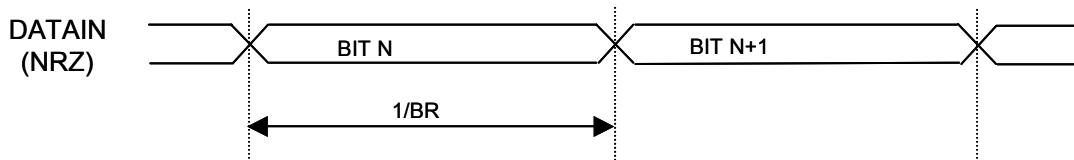

## 5.5 Received Data Interface

The outputs of the receiver are the two signals DATAOUT and DCLK. When the bit “RTParam\_Bits” is “1”, the bit synchronizer is turned on, and the two output signals are respectively the output NRZ bit stream and the sampling clock. The value of DATAOUT is valid at the rising edge of DCLK (see below).

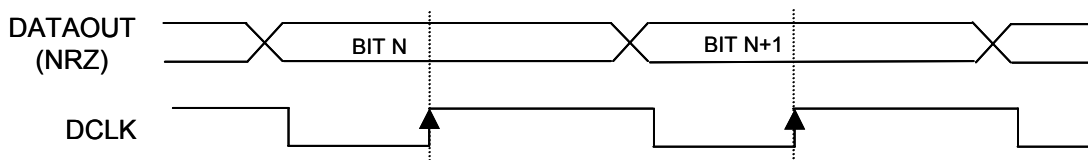

When “RTParam\_Bits” is “0”, the bit synchronizer is turned off, and the signal DATAOUT is the output of the demodulator. In this case DCLK is not used and its value is set to “low”. The maximum current drive on DATAOUT and DCLK is 2mA @ 2.7V, the maximum load is Cl<sub>op</sub>.

## 5.6 Pattern Recognition Interface

When this feature is turned on, the incoming NRZ bit stream is compared with a pattern stored in the “Pattern” register. The PATTERN output is driven by the output of this comparator and is synchronized by DCK. It is “high” when a match is detected, otherwise “low”. Changes occur at the rising edge of DCK

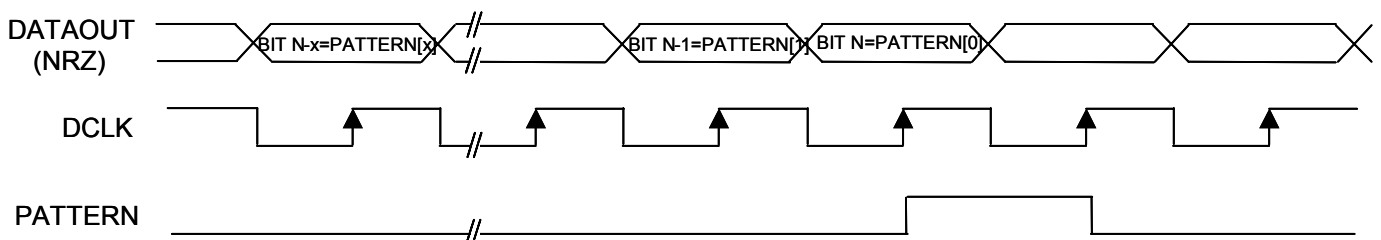

When the feature is disabled, the PATTERN output is set to “low”. The maximum current drive on PATTERN is 2mA @ 2.7V, the maximum load is Cl<sub>op</sub>.

## 5.7 Clock Output Interface

CLKOUT is a clock signal at 1.22, 2.44, 4.87, or 9.75 MHz, depending on programming. When the XE1202 is in Sleep Mode (MODE[2:0] = 000) or when "RTParam\_Clkout" is low, this clock is stopped.

## 5.8 Default settings at power-up

Upon power-up all , RTParam, FSParam, ADParam and Pattern registers are set to 00hex .

At power-up, XE1202 is in Stand-by mode, which means that the Xtal oscillator is running; furthermore, the signal at 1.22 MHz (reference frequency divided by 32) is present on pin CLKOUT. However, internally, RTParam\_Clkout is low, which means that, if nothing is changed in the configuration register, the signal on CLKOUT will disappear at the first rising edge of EN; furthermore, at this first rising edge of EN, the circuit will be put in the mode corresponding to the signals on pins MODE(2:0) at this moment. Thus, to keep the circuit in Standy-by mode and the clock signal present on CLKOUT, RTParam\_Clkout has to be set high during the first communication through the 3-wire bus, and the MODE(0) has to be set high before the first rising edge of EN.

It is strongly recommended to initialize the XE1202 registers right after power-up according to the application needs.

## 6 Application Information

### 6.1 Matching network of the receiver

The schematic of the matching network at the input of the receiver is given below

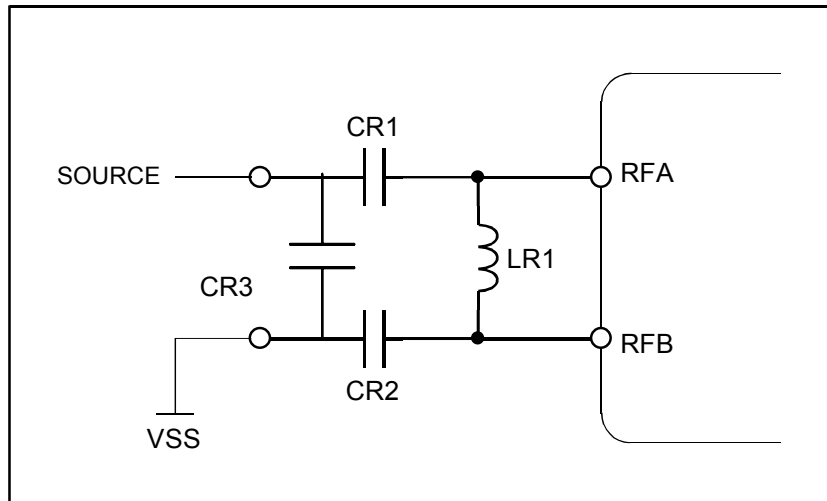

The components of the network have to satisfy the conditions given in the following table.

Name	Min. value	Typ. value	Min. Q-factor @ selected frequency range	Tolerance
CR1	0.8 pF		200	± 2 %
CR2	0.8 pF		200	± 2 %
CR3 (optional)				
LR1	8 nH		30	± 5 %

### 6.2 Matching network of the transmitter

The schematic of the matching network at the output of the transmitter is given below.

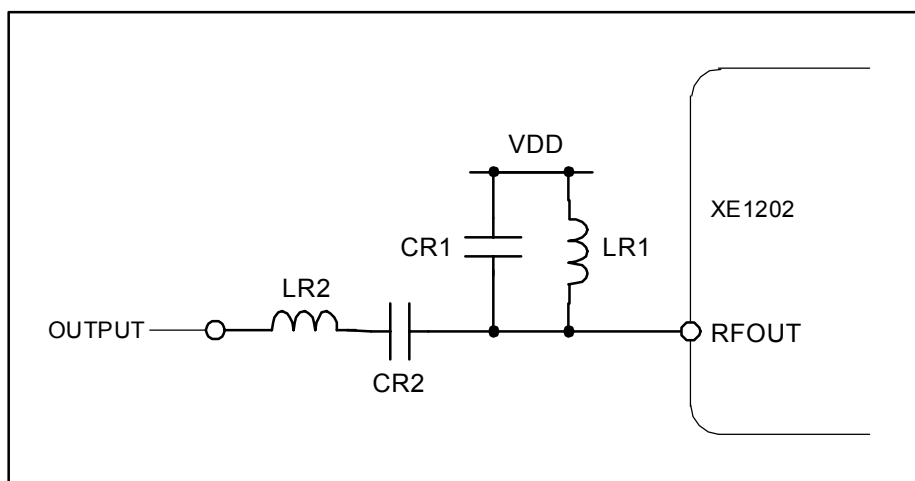

The components of the network have to satisfy the following conditions:

Name	Min. value	Typ. value	Min. Q-factor @ selected frequency range	Tolerance
CR1	0.8 pF		200	± 2 %
CR2	0.8 pF		200	± 2 %
LR1	8 nH		30	± 5 %
LR2 (optional)				

### 6.3 VCO tank

The tank of the VCO will be implemented with one inductor in parallel with one capacitor. The characteristics of these two components must be as follows:

Name	Min. value	Typ. value	Min. Q-factor @ selected frequency range	Tolerance
CV1	0.8 pF		200	± 2 %
LV1	8 nH		30	± 5 %

### 6.4 Loop filter of the frequency synthesizer

The loop filter of the frequency synthesizer is shown below.

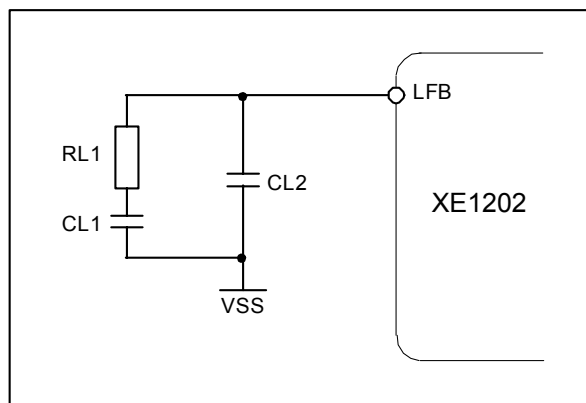

The components of the filter have to satisfy the following conditions:

Name	Min. value	Typ. value	Min. Q-factor @ selected frequency range	Tolerance
CL1	0.8 pF		200	± 2 %
CL2	0.8 pF		200	± 2 %
RL1	1 k $\Omega$		-	± 2 %



## 6.5 Reference crystal for the frequency synthesizer

For narrow band applications, where users select the lowest frequency deviation and the narrowest baseband filter, the crystal for reference oscillator of the frequency synthesizer must have the following characteristics:

Name	Description	Min. value	Typ. value	Max. value
Fs	Nominal frequency	-	39.0 MHz (fundamental)	-
CL	Load capacitance for fs (on-chip)	-	8 pF (*)	-
Rm	Motional resistance	-	-	40 $\Omega$
Cm	Motional capacitance	-	-	30 fF
C0	Shunt capacitance	-	-	7 pF (*)
$\Delta f_s(0)$	Calibration tolerance at 25 °C	-	-	10 ppm
$\Delta f_s(\Delta T)$	Stability over temperature range (-40 °C to 85 °C)	-	-	10 ppm
$\Delta f_s(\Delta t)$	Aging tolerance in first 5 years	-	-	5 ppm

Table 5 Crystal characteristics

(\*) The on-chip oscillator is implemented in two selectable versions: the first for CL = 8 pF and C0 = 7 pF, and the second for CL = 8 pF and C0 = 3 pF; the latter will allow a higher amplitude for the internal signal with a slightly lower consumption.

The electrical specifications given in section 3.2.2 are valid provided the crystal satisfies the specifications given in table 5.

For less demanding applications in term of signal bandwidth and/or temperature range, it is possible to use crystal with larger values for  $\Delta f_s(0)$ ,  $\Delta f_s(\Delta T)$ , and/or  $\Delta f_s(\Delta t)$ . In this case  $f_{offset} + BW_{ssb}$  should be lower than  $BW_{filter}$ , where  $f_{offset}$  is the offset (error) on the carrier frequency (the sum of  $\Delta f_s(0)$ ,  $\Delta f_s(\Delta T)$ , and/or  $\Delta f_s(\Delta t)$ ),  $BW_{ssb}$  is the single side-band bandwidth of the signal, and  $BW_{filter}$  is the single side-band bandwidth of the base-band filter.

XE1202 can be used with reference crystal operating on its 3<sup>rd</sup> harmonic at 39.00 MHz. This has 2 consequences: a) the oscillator start-up time is higher than in fundamental mode; and b) an extra 1.5k to 16k ohm external resistor has to be placed in parallel to the crystal. In this case, the crystal should have  $C_{load} = 8$  to 10pF,  $R_m < 60$  ohm,  $C_0 < 7$ pF.

## 6.6 Decoupling capacitances

A decoupling capacitance will be placed between each VDD pins and the ground VSS. These five capacitances must have the following characteristics:

Name	Typ. value	Tolerance
Cci	100 nF	$\pm 10$ %

## 7 Packaging information

XE1202 comes in 44-lead LQFP package

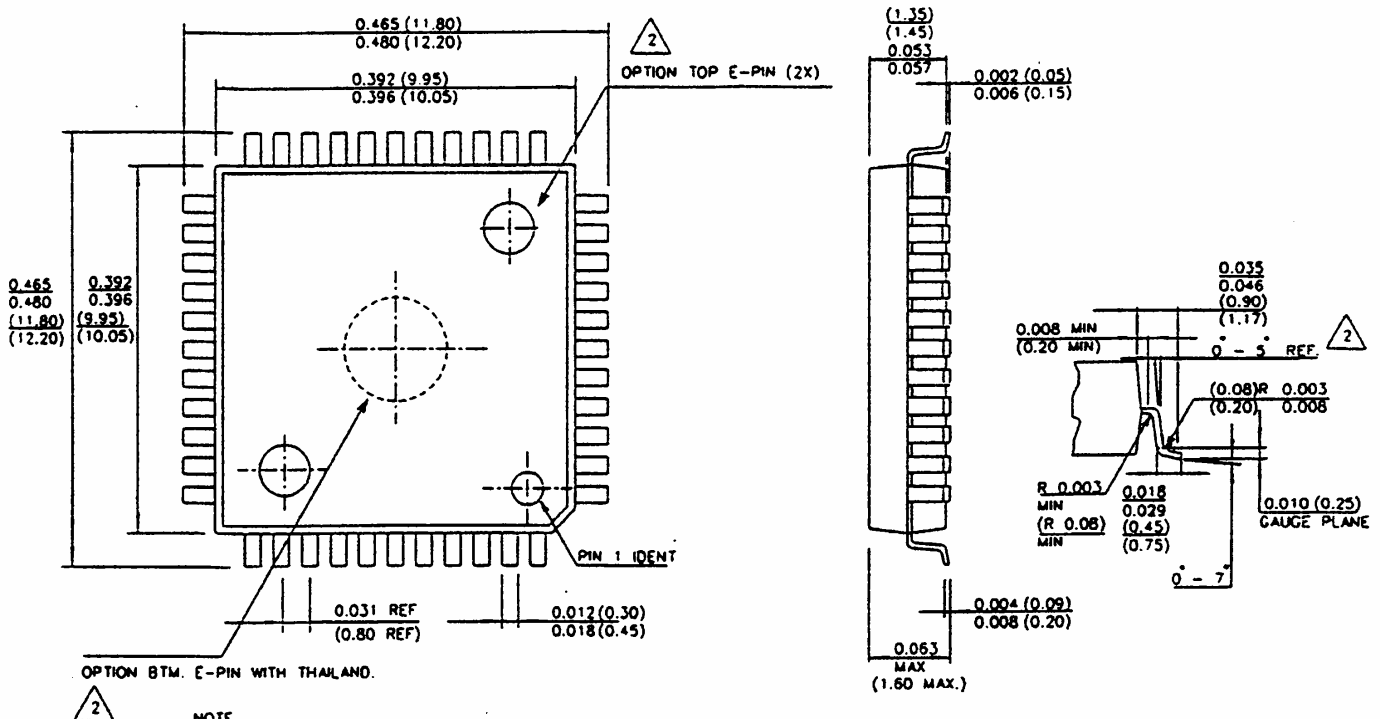
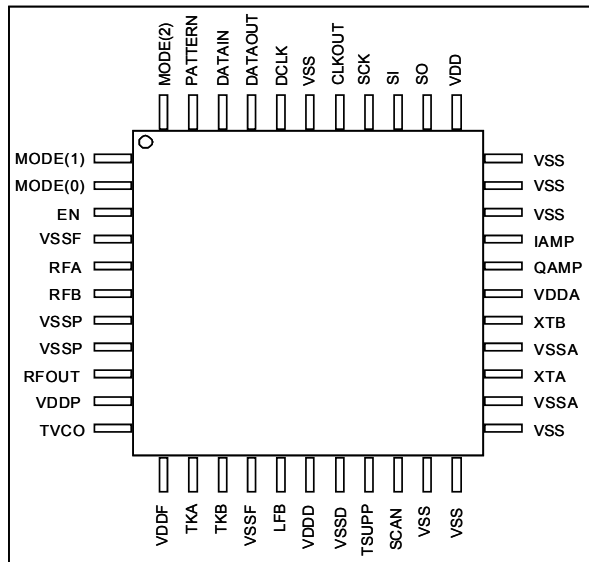

- NOTE**
1. CONTROLLED DIMENSION IS MM. DIMENSION IN BLANKET IS MILLIMETER.
  2. DIMENSIONS DO NOT INCLUDE END FLASH, MOLD FLASH, MATERIAL PROTRUSIONS.

©XEMICS 2002

All rights reserved. Reproduction in whole or in part is prohibited without the prior written consent of the copyright owner. The information presented in this document does not form part of any quotation or contract, is believed to be accurate and reliable and may be changed without notice. No liability will be accepted by the publisher for any consequence of its use. Publication thereof does not convey nor imply any license under patent or other industrial or intellectual property rights.

XEMICS PRODUCTS ARE NOT DESIGNED, INTENDED, AUTHORIZED OR WARRANTED TO BE SUITABLE FOR USE IN LIFE-SUPPORT APPLICATIONS, DEVICES OR SYSTEMS OR OTHER CRITICAL APPLICATIONS. INCLUSION OF XEMICS PRODUCTS IN SUCH APPLICATIONS IS UNDERSTOOD TO BE UNDERTAKEN SOLELY AT THE CUSTOMER'S OWN RISK.

Should a customer purchase or use XEMICS products for any such unauthorized application, the customer shall indemnify and hold XEMICS and its officers, employees, subsidiaries, affiliates, and distributors harmless against all claims, costs damages and attorney fees which could arise.