

Description

The Si4720/21 is the first single chip FM radio transceiver. The proven and patented digital architecture of the Si4720/21 combines the functionality of the Si470x FM radio receiver with the Si471x FM transmitter, offering full FM receive and transmit capabilities in a single, ultra-small 3x3x0.55 mm QFN package. The device leverages Silicon Lab's highly successful and proven FM technology, and offers unmatched integration and performance allowing FM receive and transmit to be added to any portable device by using a single chip. As with the Si470x and Si471x products, the Si4720/21 offers industry leading size, performance, low power consumption, and ease of use.

The Si4720/21's digital integration reduces the required external components of traditional offerings, resulting in a solution requiring only an external inductor and bypass capacitor, and a PCB space of approximately 15 mm². The Si4720/21 is layout compatible with Silicon Laboratories' Si470x FM radio receivers, Si473x AM/FM radio receivers, and the Si471x FM radio transmitter solutions, allowing a single PCB layout to accommodate a variety of music features. High yield manufacturability, unmatched performance, easy design-in, and software programmability are key advantages of the Si4720/21.

The Si4721 is the industry's first single-chip integrated FM radio transceiver including both receive and transmit support for the European Radio Data System (RDS) and the U.S. Radio Broadcast Data System (RBDS). RDS allows digital information sent from the broadcaster to be displayed, such as station ID, song name and music category. In Europe, alternate frequency (AF) information is also provided to automatically change stations in areas where broadcasters use multiple frequencies. In transmit mode, digital information such as artist name, song title, music category, and branded messaging can be transmitted and displayed on any RDS/RBDS receiver.

Users are responsible to adjust their system's radiated power levels to comply with local regulations on RF transmission (FCC, ETSI, ARIB, etc.).

Features

- Integrated FM antenna support
- Excellent real-world performance
- Only two external components required
- Worldwide FM band support (76 to 108 MHz)
- RDS/RBDS processor (Si4721)
- Frequency synthesizer with integrated VCO
- Adjustable seek parameters
- Adjustable mono/stereo blend
- Adjustable soft mute
- Programmable transmit output voltage control
- Audio dynamic range control
- Advanced modulation control
- Analog/digital audio interface
- Programmable reference clock input
- Programmable pre/de-emphasis (50/75 μs)
- 2-wire and 3-wire control interface
- Integrated LDO regulator
- 2.7 to 5.5 V supply voltage
- 3x3x0.55 mm 20-pin Pb-free QFN package

Applications

- Cellular handsets/hands free
- MP3 players
- Portable media players
- GPS/navigation devices
- Satellite digital audio radios
- Personal computers

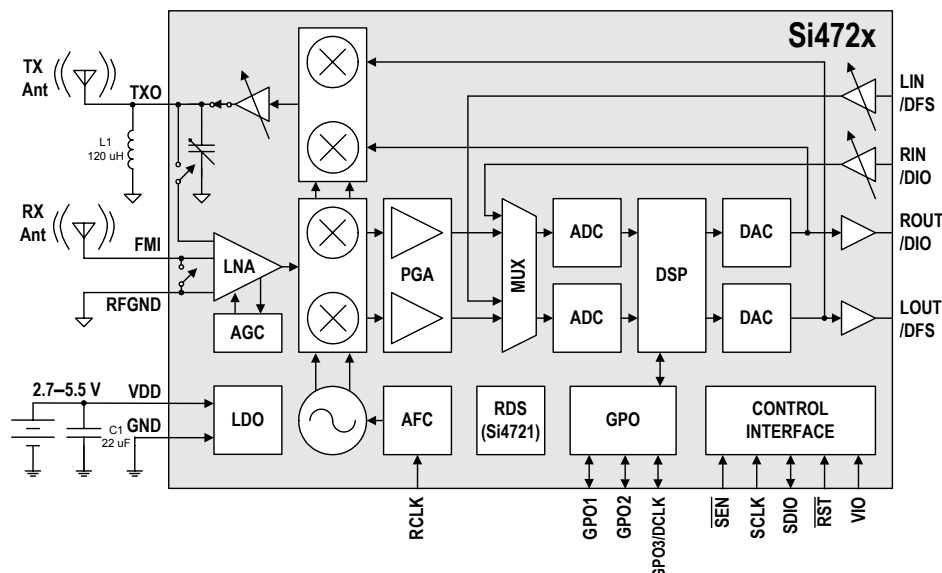

Selected Electrical Specifications

Parameter	Symbol	Test Condition	Min	Typ	Max	Unit
Frequency Range	f_{RF}		76	—	108	MHz
Sensitivity		(S+N)/N = 26 dB	—	2.2	—	μ V EMF
Input IP3		$ f_2 - f_1 > 1 \text{ MHz}; f_0 = 2 \times f_1 - f_2$ AGC disabled	—	108	—	dB μ V EMF
Adjacent Channel Selectivity		$\pm 200 \text{ kHz}$	—	50	—	dB
Alternate Channel Selectivity		$\pm 400 \text{ kHz}$	—	70	—	dB
RX Audio Output Voltage			72	80	90	mVrms
RX Audio Band Limits		$\pm 1.5 \text{ dB}$	30	—	15k	Hz
RX Audio S/N			—	63	—	dB
RX Audio THD			—	0.1	—	%
Programmable Transmit Output Voltage, TXO (Maximum Voltage)			—	115	—	dB μ V
Programmable Transmit Output Voltage, TXO (Minimum Voltage)			—	83	—	dB μ V
Transmit Voltage Stability			-1	—	1	dB
Transmit Voltage Step			—	1	2	dB
Transmit Channel Edge Power			—	—	-20	dBc
Transmit Adjacent Channel Power			—	-30	-26	dBc
Pre/de-emphasis Time Constant		FMPE[1:0] = 00	70	75	80	us
		FMPE[1:0] = 01	45	50	54	us
TX Audio SNR			—	63	—	dB
TX Audio THD			—	0.1	—	%
TX Audio Stereo Separation			30	35	—	dB
TX Sub Carrier Rejection Ratio	SCR		—	-50	-40	dB
TX Audio Input Signal Level (0 dB)	V_{AI}	$V_{IO} = 1.8 \text{ V}$	—	—	0.636	V_{pk}

Pin Assignments

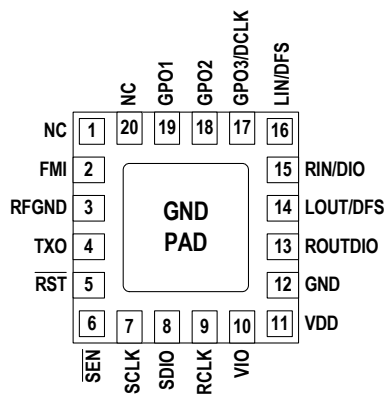

Package Information

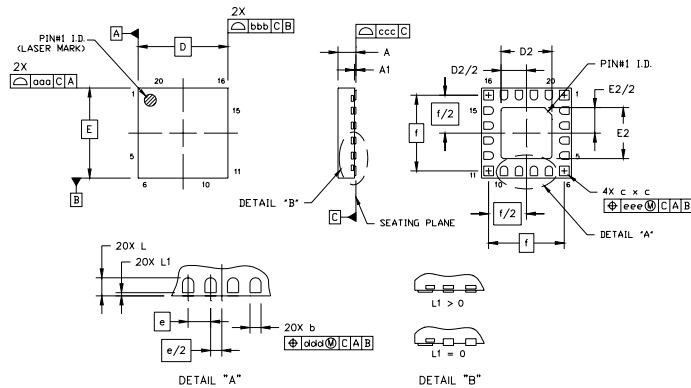

Symbol	Millimeters		
	Min	Nom	Max
A	0.50	0.55	0.60
A1	0.00	0.02	0.05
b	0.18	0.25	0.30
c	0.27	0.32	0.37
D	3.00 BSC		
D2	1.60	1.70	1.80
e	0.50 BSC		
E	3.00 BSC		
E2	1.60	1.70	1.80

Symbol	Millimeters		
	Min	Nom	Max
f	2.53 BSC		
L	0.35	0.40	0.45
L1	0.00	—	0.10
aaa	—	—	0.10
bbb	—	—	0.10
ccc	—	—	0.08
ddd	—	—	0.10
eee	—	—	0.10