

## Built-in Inrush Current Protection, 300mA High Speed LDO Voltage Regulator

## ■ GENERAL DESCRIPTION

The XC6223 series is a high speed LDO regulator that features high accurate, low noise, high ripple rejection, low dropout and low power consumption. The series consists of a voltage reference, an error amplifier, a driver transistor, a current limiter, a phase compensation circuit, a thermal shutdown circuit and an inrush current protection circuit.

The CE function enables the circuit to be in stand-by mode by inputting low level signal. In the stand-by mode, the series enables the electric charge at the output capacitor  $C_L$  to be discharged via the internal switch, and as a result the  $V_{OUT}$  pin quickly returns to the  $V_{SS}$  level. The output stabilization capacitor  $C_L$  is also compatible with low ESR ceramic capacitors.

The output voltage is selectable in 0.05V increments within the range of 1.2V to 4.0V which fixed by laser trimming technologies. The over current protection circuit and the thermal shutdown circuit are built-in. These two protection circuits will operate when the output current reaches current limit level or the junction temperature reaches temperature limit level.

## ■ APPLICATIONS

- Digital still cameras
- Cell phones
- Portable games
- Camera modules
- IC recorders
- Portable media players
- Bluetooth
- Wireless LAN
- Terrestrial digital TV tuners
- Cordless phones

## ■ FEATURES

<b>Maximum Output Current</b>	: 300mA
<b>Input Voltage Range</b>	: 1.6~5.5V
<b>Output Voltages</b>	: 2.0~4.0V (Accuracy $\pm 1\%$ ) 1.2~1.95V (Accuracy $\pm 20mV$ ) 0.05V increments
<b>Dropout Voltage</b>	: 200mV@ $I_{OUT}=300mA$ ( $V_{OUT}=3.0V$ )
<b>Low Power Consumption</b>	: 100 $\mu A$
<b>Stand-by Current</b>	: 0.1 $\mu A$
<b>High Ripple Rejection</b>	: 80dB@f=1kHz
<b>Protection Circuits</b>	: Current Limit (400mA) Short Circuit Protection Over Heat Protection Inrush Current Protection
<b>Low ESR Capacitors</b>	: $C_{IN}=1.0 \mu F$ , $C_L=1.0 \mu F$
<b>CE Function</b>	: Active High $C_L$ High Speed Discharge
<b>Small Packages</b>	: USPQ-4B03 USP-4 SSOT-24 SOT-25 SOT-89-5
<b>Environmentally Friendly</b>	: EU RoHS Compliant, Pb Free

## ■ TYPICAL APPLICATION CIRCUIT

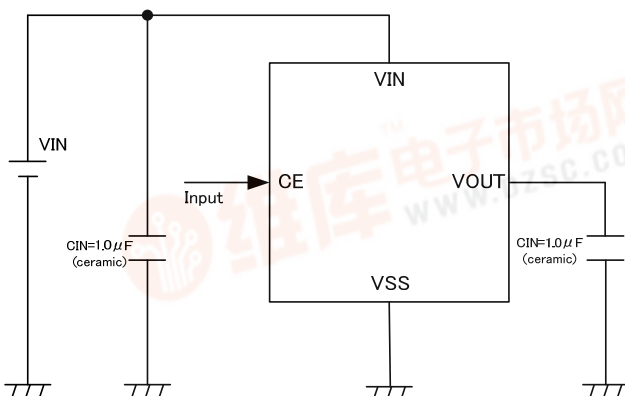

## ■ TYPICAL PERFORMANCE CHARACTERISTICS

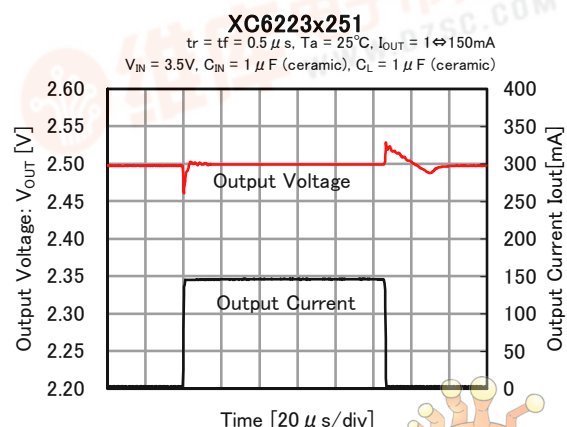

# XC6223 Series

[查询XC6223供应商](#)

## PIN CONFIGURATION

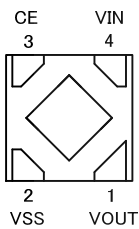

USPQ-4B03  
(BOTTOM VIEW)

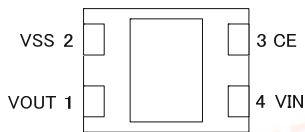

USP-4  
(BOTTOM VIEW)

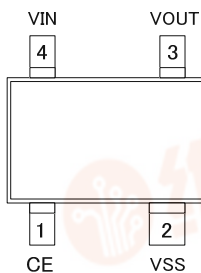

SSOT-24  
(TOP VIEW)

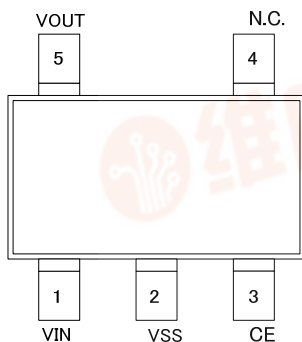

SOT-25  
(TOP VIEW)

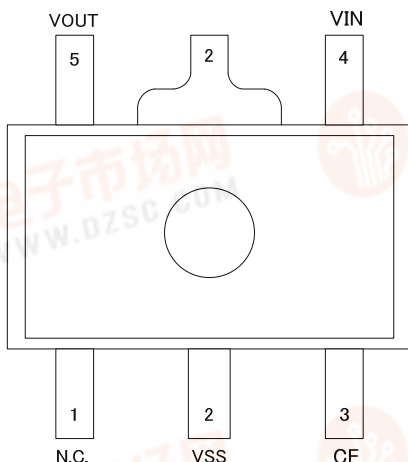

SOT-89-5  
(TOP VIEW)

\*The dissipation pad for the USPQ-4B03, USP-4 packages should be solder-plated in reference mount pattern and metal masking so as to enhance mounting strength and heat release. If the pad needs to be connected to other pins, it should be connected to the V<sub>SS</sub> (No. 2) pin.

## PIN ASSIGNMENT

PIN NUMBER					PIN NAME	FUNCTIONS
USPQ-4B03	USP-4	SSOT-24	SOT-25	SOT-89-5		
4	4	4	1	4	V <sub>IN</sub>	Power Input
1	1	3	5	5	V <sub>OUT</sub>	Output
2	2	2	2	2	V <sub>SS</sub>	Ground
3	3	1	3	3	CE	ON/OFF Control
-	-	-	4	1	NC	No Connection

## PIN FUNCTION ASSIGNMENT

CE Ethics Condition	IC Operation State ON/OFF
H	Operation ON
L	Operation OFF(Stand-by)
OPEN	*

\* Undefined state in XC6223 A/B/E/F. On the other hand, Operation OFF states in XC6223C/D/G/H because that an internal pull-down resistor maintains the CE pin voltage to be low.

[查询XC6223供应商](#)

## PRODUCT CLASSIFICATION

● Ordering Information

XC6223①②③④⑤⑥-⑦<sup>(\*)</sup>

DESIGNATOR	ITEM	SYMBOL	DESCRIPTION		
①	Type of Regulator (CE active high)		Inrush Current Protection	CE Pull-Down Resistor	C <sub>L</sub> Discharge
		A	NO	NO	NO
		B	NO	NO	YES
		C	NO	YES (1MΩ, TYP built-in)	NO
		D	NO	YES (1MΩ, TYP built-in)	YES
		E	YES	NO	NO
		F	YES	NO	YES
		G	YES	YES (1MΩ, TYP built-in)	NO
		H (The Recommended Type)	YES	YES (1MΩ, TYP built-in)	YES
②③	Output Voltage	12~40	ex.) 2.80V → ②=2, ③=8, ④=please see down below.		
④	Output Voltage (2 <sup>nd</sup> decimal place)	1	ex.) 2.80V → ④=1		
		B	ex.) 2.85V → ④=B		
⑤⑥-⑦ <sup>(*)</sup>	Packages (Order Unit)	9R-G	USPQ-4B03 (5,000/Reel)		
		GR-G	USP-4 (3,000/Reel)		
		NR-G	SSOT-24 (3,000/Reel)		
		MR-G	SOT-25 (3,000/Reel)		
		PR-G	SOT-89-5 (3,000/Reel)		

<sup>(\*)</sup> The "-G" suffix indicates that the products are Halogen and Antimony free as well as being fully RoHS compliant.

# XC6223 Series

[查询XC6223供应商](#)

## BLOCK DIAGRAMS

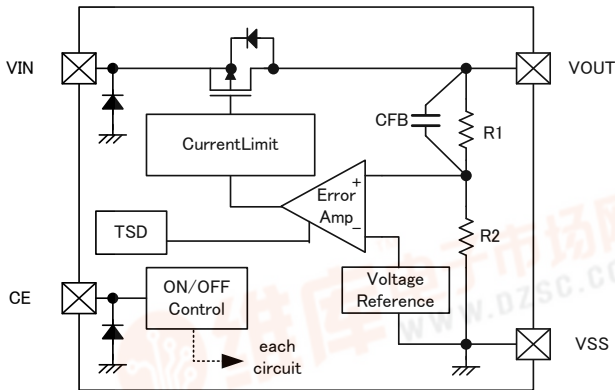

XC6223Aseries

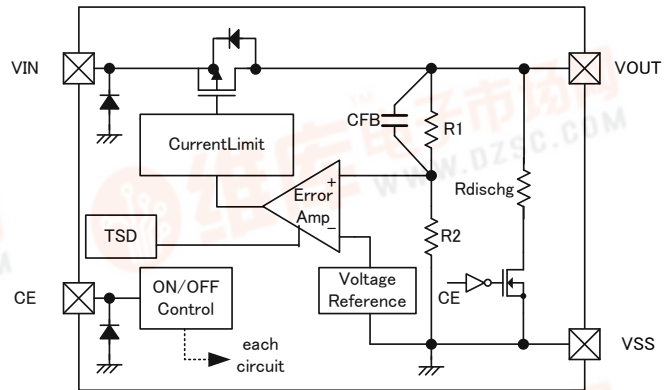

XC6223Bseries

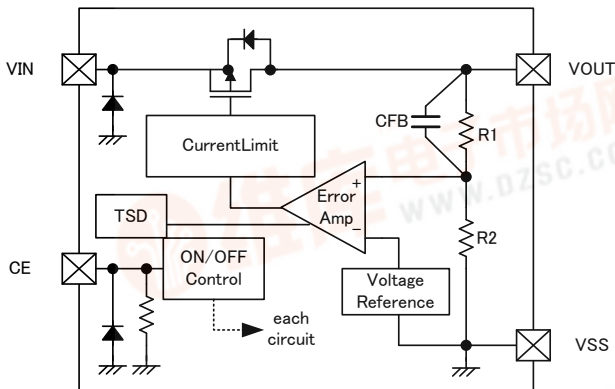

XC6223Cseries

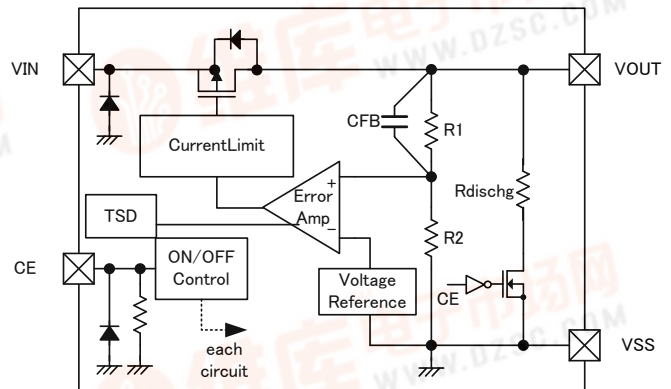

XC6223Dseries

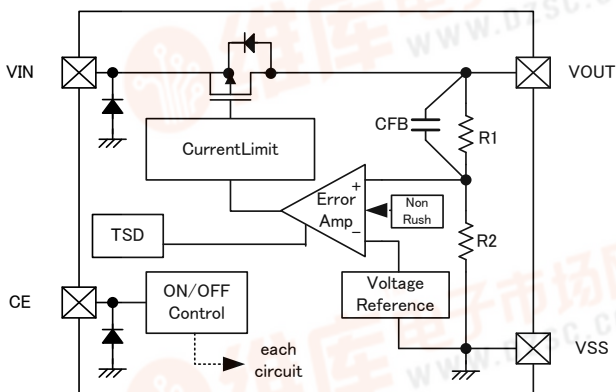

XC6223Eseries

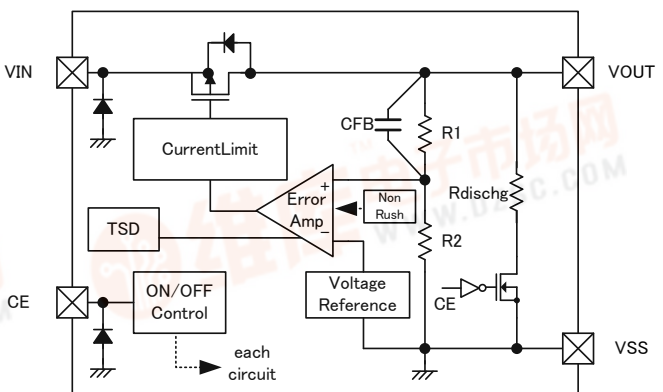

XC6223Fseries

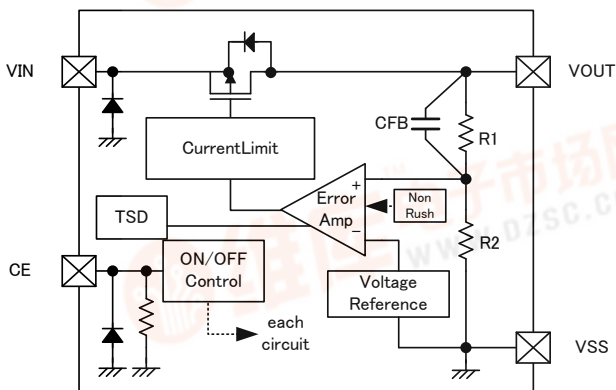

XC6223Gseries

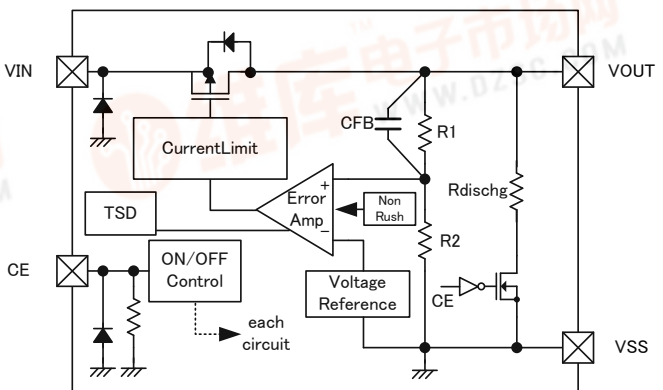

XC6223Hseries

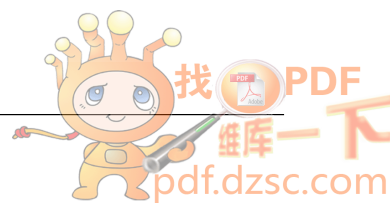

[查询XC6223供应商](#)

## ■ ABSOLUTE MAXIMUM RATINGS

PARAMETER		SYMBOL	RATINGS	UNITS
Input Voltage		$V_{IN}$	$V_{SS}-0.3\sim+7.0$	V
Output Current		$I_{OUT}$	500 <sup>(*1)</sup>	mA
Output Voltage		$V_{OUT}$	$V_{SS}-0.3\sim V_{IN}+0.3$	V
CE Input Voltage		$V_{CE}$	$V_{SS}-0.3\sim+7.0$	V
Power Dissipation	USPQ-4B03	Pd	100	mW
			550 (PCB mounted) <sup>(*2)</sup>	
	USP-4		120	
			1000 (PCB mounted) <sup>(*2)</sup>	
	SSOT-24		150	
			500 (PCB mounted) <sup>(*2)</sup>	
SOT-25	250			
SOT-89-5	600 (PCB mounted) <sup>(*2)</sup>			
	500			
Operating Temperature Range		$T_{opr}$	-40~+85	°C
Storage Temperature Range		$T_{stg}$	-55~+125	°C

(\*1) :  $I_{OUT} \leq Pd / (V_{IN} - V_{OUT})$

(\*2) : The power dissipation figure shown is PCB mounted. Please refer to page 26~29 for details.

# XC6223 Series

查询XC6223供应商

## ELECTRICAL CHARACTERISTICS

●XC6223A/B/C/D/E/F/G/H Series

Ta=25°C

PARAMETER	SYMBOL	CONDITIONS	MIN.	TYP.	MAX.	UNITS	CIRCUITS
Output Voltage	V <sub>OUT(E)</sub> <sup>(*1)</sup>	V <sub>OUT(T)</sub> ≥ 2.0V, V <sub>CE</sub> = V <sub>IN</sub> , I <sub>OUT</sub> = 10mA	V <sub>OUT(T)</sub> × 0.99 <sup>(*2)</sup>	V <sub>OUT(T)</sub> <sup>(*2)</sup>	V <sub>OUT(T)</sub> × 1.01 <sup>(*2)</sup>	V	①
		V <sub>OUT(T)</sub> < 2.0V, V <sub>CE</sub> = V <sub>IN</sub> , I <sub>OUT</sub> = 10mA <sup>(*3)</sup>	V <sub>OUT(T)</sub> - 20mV <sup>(*2)</sup>	V <sub>OUT(T)</sub> <sup>(*2)</sup>	V <sub>OUT(T)</sub> + 20mV <sup>(*2)</sup>	V	
Maximum Output Current	I <sub>OUTMAX</sub>	V <sub>CE</sub> = V <sub>IN</sub>	300	-	-	mA	①
Load Regulation	ΔV <sub>OUT</sub>	V <sub>CE</sub> = V <sub>IN</sub> , 0.1mA ≤ I <sub>OUT</sub> ≤ 300mA	-	25	45	mV	①
Dropout Voltage	V <sub>dif</sub> <sup>(*4)</sup>	V <sub>CE</sub> = V <sub>IN</sub> , I <sub>OUT</sub> = 300mA	E-1			mV	①
Supply Current	I <sub>SS</sub>	V <sub>CE</sub> = V <sub>IN</sub>	-	100	220	μA	②
Stand-by Current	I <sub>stby</sub>	V <sub>CE</sub> = V <sub>SS</sub>	-	0.01	0.4	μA	②
Line Regulation	ΔV <sub>OUT</sub> / (ΔV <sub>IN</sub> · V <sub>OUT</sub> )	V <sub>OUT(T)</sub> + 0.5V ≤ V <sub>IN</sub> ≤ 5.5 V V <sub>CE</sub> = V <sub>IN</sub> , I <sub>OUT</sub> = 50mA	-	0.01	0.1	%/V	①
Input Voltage	V <sub>IN</sub>	-	1.6	-	5.5	V	①
Output Voltage Temperature Characteristics	ΔV <sub>OUT</sub> / (ΔTa · V <sub>OUT</sub> )	V <sub>CE</sub> = V <sub>IN</sub> , I <sub>OUT</sub> = 10mA -40°C ≤ Ta ≤ 85°C	-	±100	-	ppm / °C	①
Ripple Rejection Rate	PSRR	V <sub>OUT(T)</sub> < 2.5V V <sub>IN</sub> = 3.0V <sub>DC</sub> + 0.5V <sub>p-pAC</sub> V <sub>CE</sub> = V <sub>OUT(T)</sub> + 1.0V I <sub>OUT</sub> = 30mA, f = 1kHz	-	80	-	dB	③
		V <sub>OUT(T)</sub> ≥ 2.5V V <sub>IN</sub> = {V <sub>OUT(T)</sub> + 1.0} V <sub>DC</sub> + 0.5V <sub>p-pAC</sub> V <sub>CE</sub> = V <sub>OUT(T)</sub> + 1.0V I <sub>OUT</sub> = 30mA, f = 1kHz					
Current Limit	I <sub>LIM</sub>	V <sub>CE</sub> = V <sub>IN</sub>	310	400	-	mA	①
Short Current	I <sub>SHORT</sub>	V <sub>CE</sub> = V <sub>IN</sub> , V <sub>OUT</sub> = V <sub>SS</sub>	-	50	-	mA	①
CE High Level Voltage	V <sub>CEH</sub>	-	1.0	-	5.5	V	④
CE Low Level Voltage	V <sub>CEL</sub>	-	-	-	0.3	V	④
CE High Level Current (A/B/E/F Type)	I <sub>CEH</sub>	V <sub>CE</sub> = V <sub>IN</sub> = 5.5V	-0.1	-	0.1	μA	④
CE High Level Current (C/D/G/H Type)	I <sub>CEH</sub>	V <sub>CE</sub> = V <sub>IN</sub> = 5.5V	3.0	5.5	9.0	μA	④
CE Low Level Current	I <sub>CEL</sub>	V <sub>CE</sub> = V <sub>SS</sub>	-0.1	-	0.1	μA	④
CL Discharge Resistance (Only B/D/F/H Type)	R <sub>DCHG</sub>	V <sub>IN</sub> = 5.5V, V <sub>OUT</sub> = 2.0V, V <sub>CE</sub> = V <sub>SS</sub>	-	300	-	Ω	①
Inrush Current (Only E/F/G/H Type)	I <sub>rush</sub>	V <sub>IN</sub> = V <sub>CE</sub> = 5.5V	-	150	-	mA	⑤
Thermal Shutdown Detect Temperature	T <sub>TSD</sub>	Junction Temperature	-	150	-	°C	①
Thermal Shutdown Release Temperature	T <sub>TSR</sub>	Junction Temperature	-	120	-	°C	
Thermal Shutdown Hysteresis Width	T <sub>TSD</sub> - T <sub>TSR</sub>	Junction Temperature	-	30	-	°C	

NOTE:

\*1: V<sub>OUT(E)</sub>: Effective output voltage  
(i.e. the output voltage when "V<sub>OUT(T)</sub>+1.0V" is provided at the V<sub>IN</sub> pin while maintaining a certain I<sub>OUT</sub> value.)

\*2: V<sub>OUT(T)</sub>: Nominal output voltage

\*3: The standard output voltage is specified in V<sub>OUT(T)</sub> ± 20mV where V<sub>OUT(T)</sub> < 2.0V.

\*4: V<sub>dif</sub> = {V<sub>IN1</sub>{\*5} - V<sub>OUT1</sub>{\*6}} (V<sub>IN1</sub> ≥ 1.6V)

\*5: V<sub>IN1</sub> = The input voltage when V<sub>OUT1</sub> appears as input voltage is gradually decreased.

\*6: V<sub>OUT1</sub> = A voltage equal to 98% of the output voltage whenever an amply stabilized I<sub>OUT</sub> {V<sub>OUT(T)</sub>+1.0V} is input

\*7: Unless otherwise stated regarding input voltage conditions, V<sub>IN</sub> = V<sub>OUT(T)</sub> + 1.0V.



[查询XC6223供应商](#)

**ELECTRICAL CHARACTERISTICS (Continued)**

● Voltage Chart 1

SYMBOL PARAMETER NOMINAL OUTPUT VOLTAGE (V)	E-0		E-1	
	OUTPUT VOLTAGE (V)		DROPOUT VOLTAGE (mV)	
	$V_{OUT(E)}$		Vdif	
$V_{OUT(T)}$	MIN	MAX	TYP	MAX
1.20	1.1800	1.2200	480	630
1.25	1.2300	1.2700		
1.30	1.2800	1.3200	440	480
1.35	1.3300	1.3700		
1.40	1.3800	1.4200	420	460
1.45	1.4300	1.4700		
1.50	1.4800	1.5200		
1.55	1.5300	1.5700		
1.60	1.5800	1.6200	400	440
1.65	1.6300	1.6700		
1.70	1.6800	1.7200		
1.75	1.7300	1.7700		
1.80	1.7800	1.8200	300	410
1.85	1.8300	1.8700		
1.90	1.8800	1.9200		
1.95	1.9300	1.9700		
2.00	1.9800	2.0200	270	380
2.05	2.0295	2.0705		
2.10	2.0790	2.1210		
2.15	2.1285	2.1715		
2.20	2.1780	2.2220		
2.25	2.2275	2.2725		
2.30	2.2770	2.3230		
2.35	2.3265	2.3735		
2.40	2.3760	2.4240	240	350
2.45	2.4255	2.4745		
2.50	2.4750	2.5250		
2.55	2.5245	2.5755		
2.60	2.5740	2.6260		
2.65	2.6235	2.6765		
2.70	2.6730	2.7270		
2.75	2.7225	2.7775		

## ■ ELECTRICAL CHARACTERISTICS (Continued)

● Voltage Chart2

SYMBOL	E-0		E-1	
PARAMETER	OUTPUT VOLTAGE (V)		DROPOUT VOLTAGE (mV)	
NOMINAL OUTPUT VOLTAGE (V)	$V_{OUT(E)}$		Vdif	
$V_{OUT(T)}$	MIN.	MAX.	TYP.	MAX.
2.80	2.7720	2.8280	240	350
2.85	2.8215	2.8785		
2.90	2.8710	2.9290		
2.95	2.9205	2.9795		
3.00	2.9700	3.0300		
3.05	3.0195	3.0805		
3.10	3.0690	3.1310		
3.15	3.1185	3.1815	200	305
3.20	3.1680	3.2320		
3.25	3.2175	3.2825		
3.30	3.2670	3.3330		
3.35	3.3165	3.3835		
3.40	3.3660	3.4340		
3.45	3.4155	3.4845		
3.50	3.4650	3.5350		
3.55	3.5145	3.5855		
3.60	3.5640	3.6360		
3.65	3.6135	3.6865		
3.70	3.6630	3.7370		
3.75	3.7125	3.7875		
3.80	3.7620	3.8380		
3.85	3.8115	3.8885		
3.90	3.8610	3.9390		
3.95	3.9105	3.9895		
4.00	3.9600	4.0400		



[查询XC6223供应商](#)

## ■ OPERATIONAL EXPLANATION

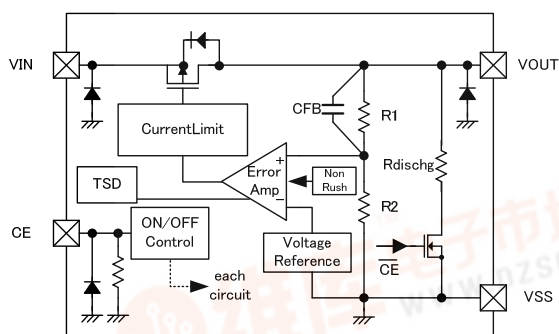

The voltage divided by resistors R1 & R2 is compared with the internal reference voltage by the error amplifier. The P-channel MOSFET which is connected to the V<sub>OUT</sub> pin is then driven by the subsequent output signal. The output voltage at the V<sub>OUT</sub> pin is controlled and stabilized by a system of negative feedback. The current limit circuit and short circuit protection operate in relation to the level of output current and heat dissipation. Further, the IC's internal circuitry can be shutdown via the CE pin signal.

### <Low ESR Capacitor>

The XC6223 series needs an output capacitor  $C_L$  for phase compensation. In order to ensure the stable phase compensation, please place an output capacitor of  $1.0 \mu\text{F}$  or bigger at the V<sub>OUT</sub> pin and V<sub>SS</sub> pin as close as possible. For a stable power input, please connect an input capacitor ( $C_{IN}$ ) of  $1.0 \mu\text{F}$  between the V<sub>IN</sub> pin and the V<sub>SS</sub> pin.

### <Current Limiter, Short-Circuit Protection>

The protection circuit operates as a combination of an output current limiter and fold-back short circuit protection. When load current reaches the current limit level, the output voltage drops. As a result, the load current starts to reduce with showing fold-back curve. The output current finally falls at the level of 50mA when the output pin is short-circuited.

### <CE Pin>

The IC's internal circuitry can be shutdown via the signal from the CE pin. In shutdown mode, the XC6223B/D/F/H series enables the electric charge at the output capacitor ( $C_L$ ) to be discharged via the internal auto-discharge switch, and as a result the V<sub>OUT</sub> pin quickly returns to the V<sub>SS</sub> level. When the CE pin is open, the output voltage becomes undefined state in the XC6223A/B/E/F series because of a high active and no pull-down. On the other hand, the XC6223C/D/G/H series has a pull-down resistor at the CE pin inside, so that the CE pin input current flows.

### <Thermal Shutdown>

The over heat protection circuit is built-in with the XC6223 series. When the junction temperature of the IC reaches the temperature limit level ( $150^\circ\text{C}$  TYP.), the thermal shutdown circuit operates and the driver transistor will be turned off. The IC resumes its operation when the thermal shutdown function is released as a result of the junction temperature drops to the release point.

### <Inrush Current Protection>

The inrush current protection circuit is built in the XC6223 series.

When the IC starts to operate, the protection circuit limits the inrush current from V<sub>IN</sub> to V<sub>OUT</sub> to charge  $C_L$  capacitor. This function is built in the XC6223E/F/G/H series.

## NOTES ON USE

1. Where wiring impedance is high, operations may become unstable due to the noise and/or phase lag depending on output current. Please strengthen  $V_{IN}$  and  $V_{SS}$  wiring in particular.
2. The input capacitor  $C_{IN}$  and the output capacitor  $C_L$  should be placed to the as close as possible with a shorter wiring.
3. The IC is controlled with constant current start-up. Start-up sequence control is requested to draw a load current after rising up the output voltage.
4. For temporary, transitional voltage drop or voltage rising phenomenon, the IC is liable to malfunction should the ratings be exceeded.
5. Torex places an importance on improving our products and its reliability. However, by any possibility, we would request user fail-safe design and post-aging treatment on system or equipment.

[查询XC6223供应商](#)

## TEST CIRCUITS

### ● Circuit ①

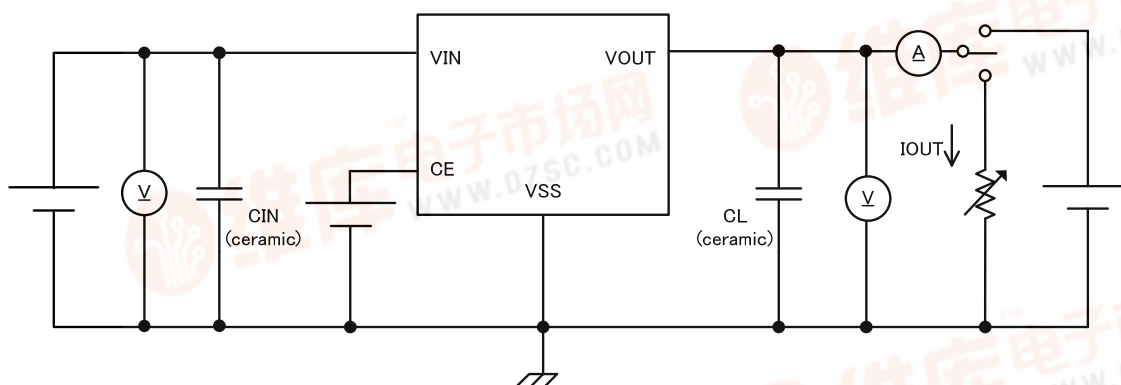

### ● Circuit ②

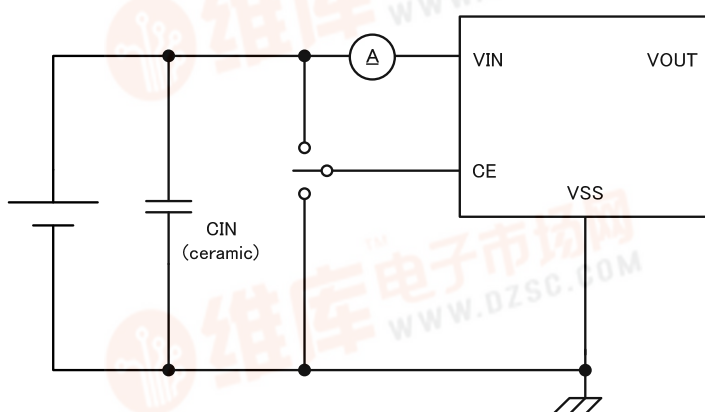

### ● Circuit ③

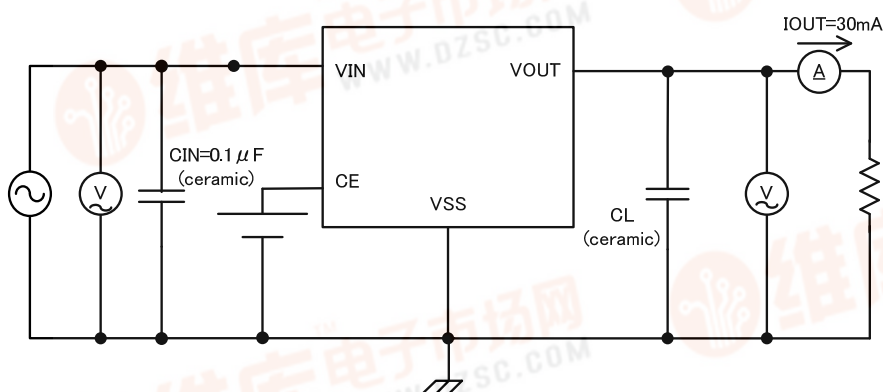

# XC6223 Series

[查询XC6223供应商](#)

## TEST CIRCUITS (Continued)

● Circuit ④

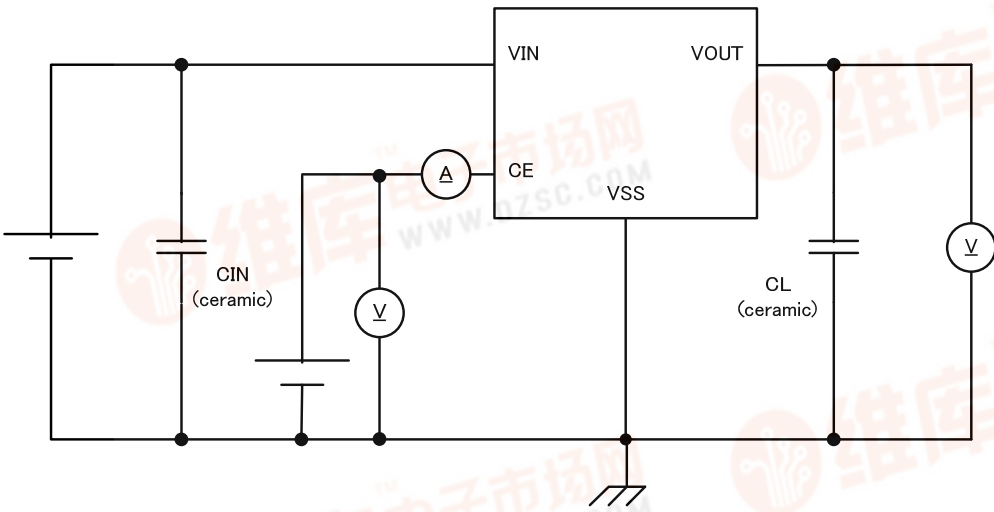

● Circuit ⑤

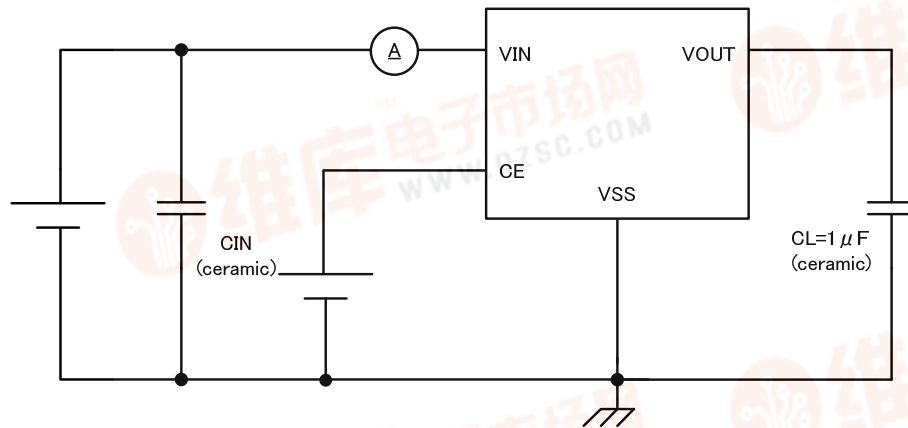

[查询XC6223供应商](#)

## ■ TYPICAL PERFORMANCE CHARACTERISTICS

(1) Output Voltage vs. Output Current

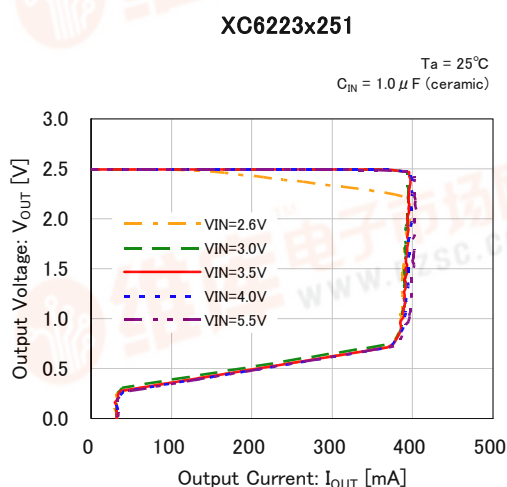
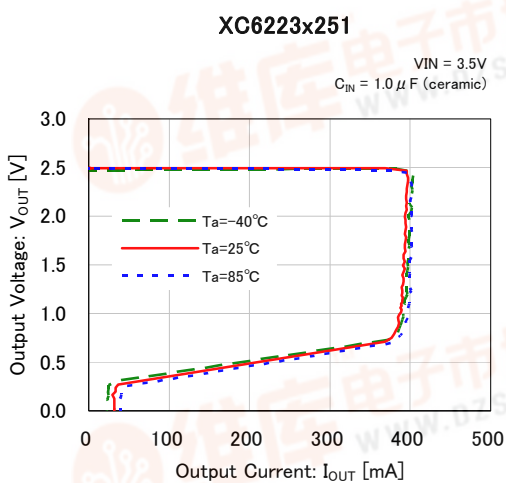
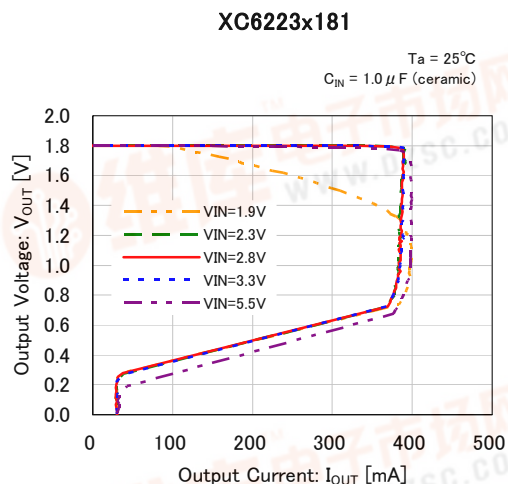
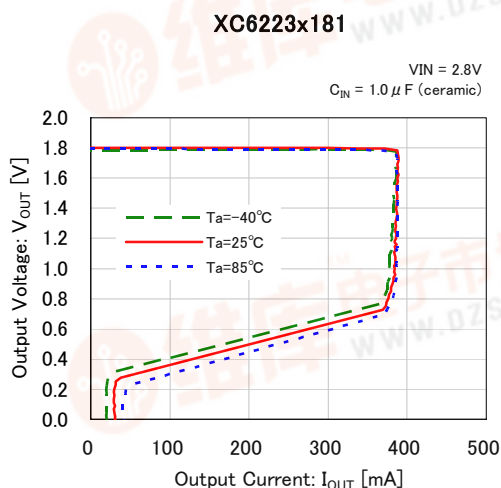
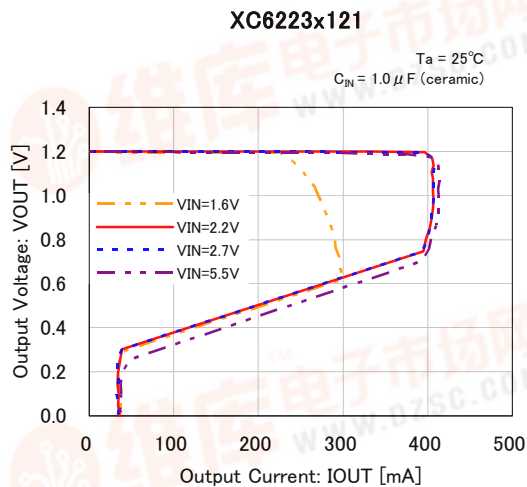
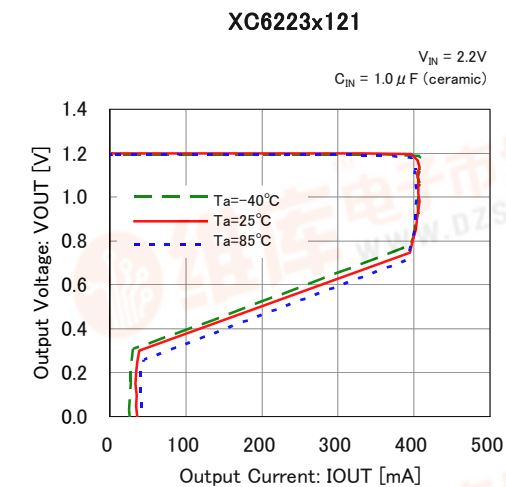

## TYPICAL PERFORMANCE CHARACTERISTICS (Continued)

### (1) Output Voltage vs. Output Current (Continued)

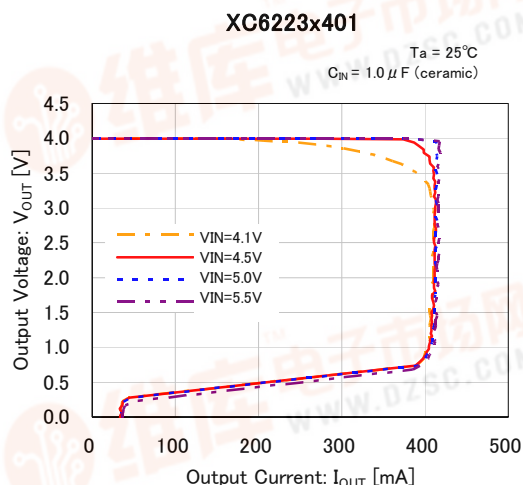
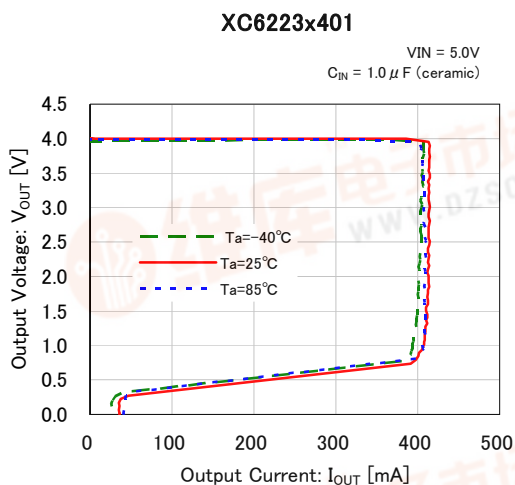

### (2) Output Voltage vs. Input Voltage

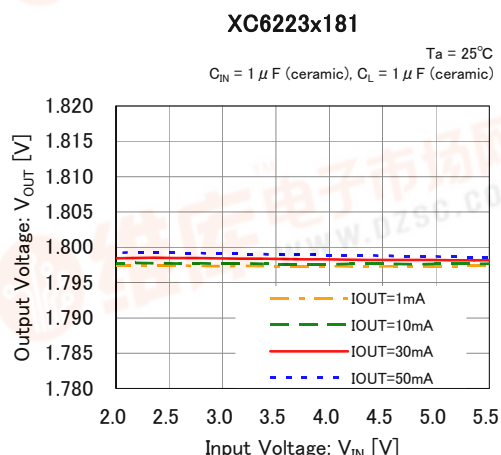
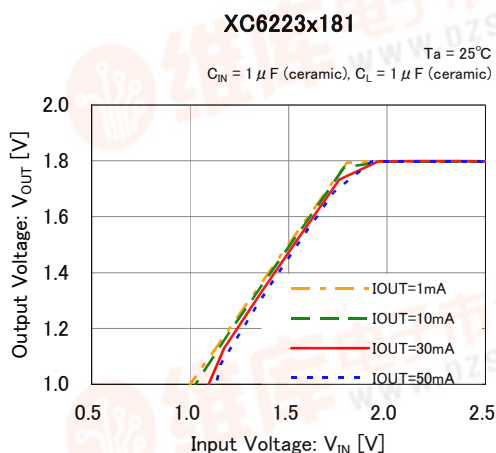
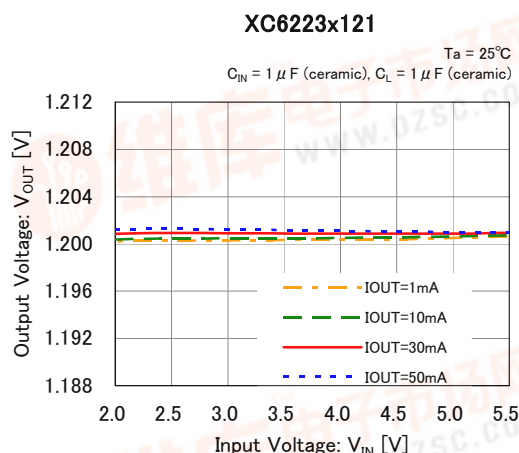
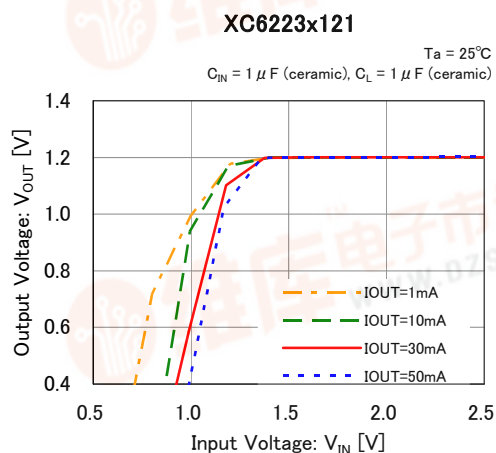

[查询XC6223供应商](#)

## ■ TYPICAL PERFORMANCE CHARACTERISTICS (Continued)

### (2) Output Voltage vs. Input Voltage (Continued)

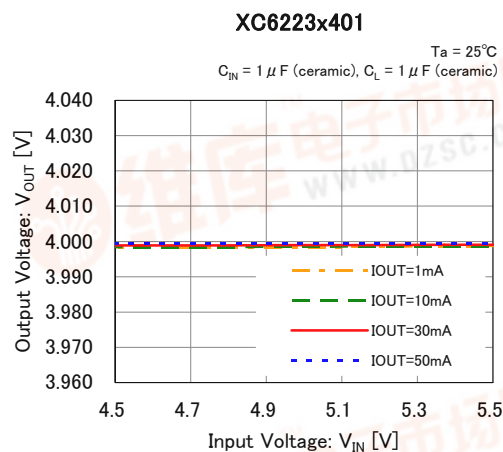
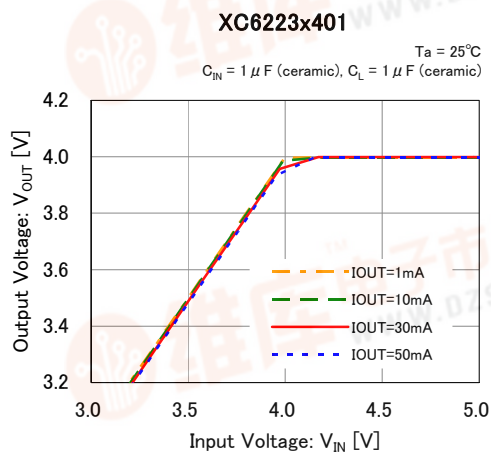
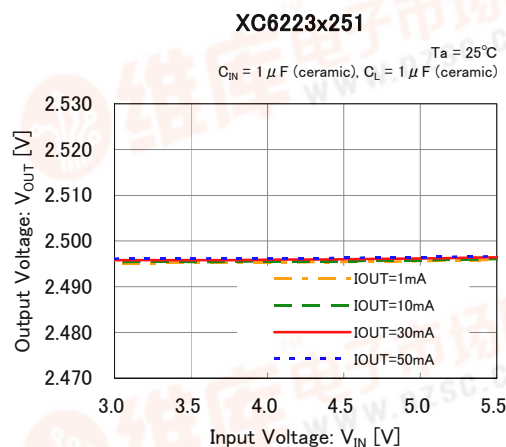
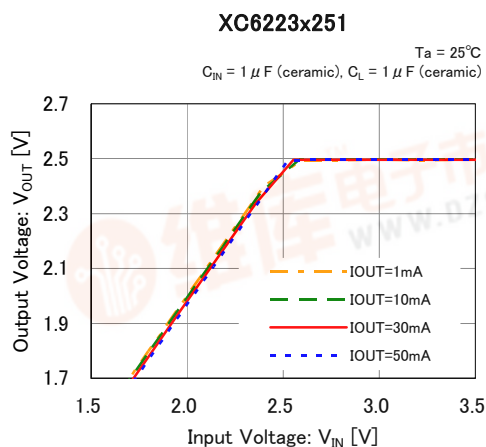

### (3) Dropout Voltage vs. Output Current

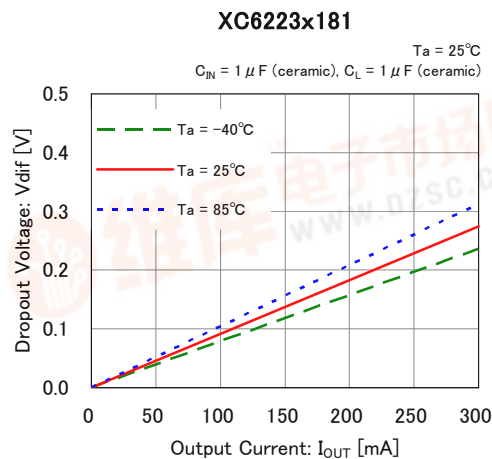
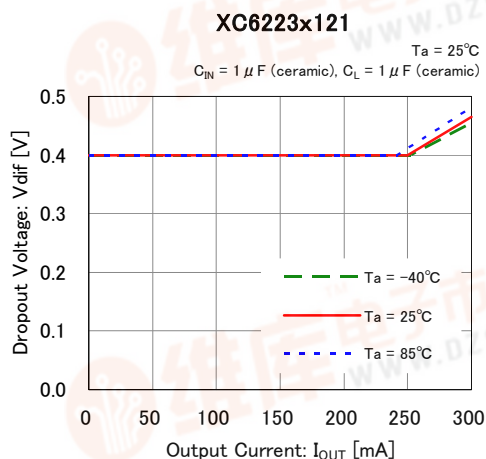

## TYPICAL PERFORMANCE CHARACTERISTICS (Continued)

### (3) Dropout Voltage vs. Output Current (Continued)

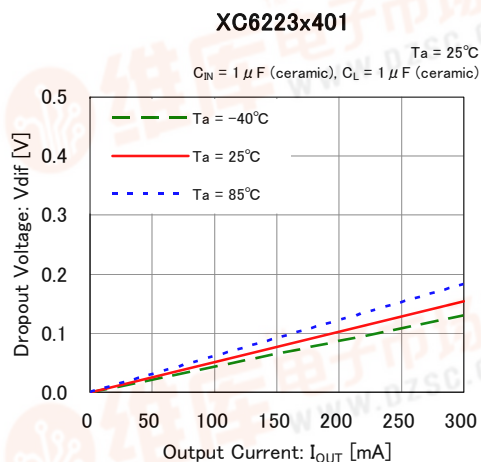
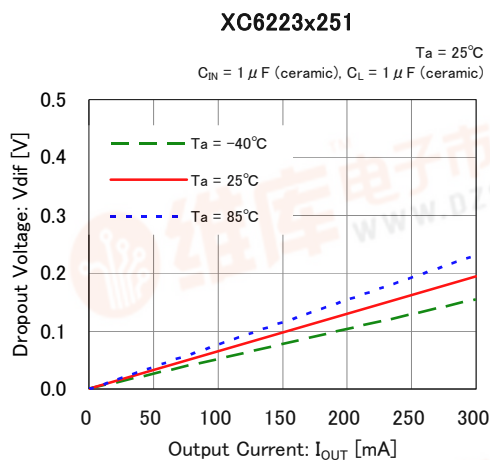

### (4) Supply Current vs. Input Voltage

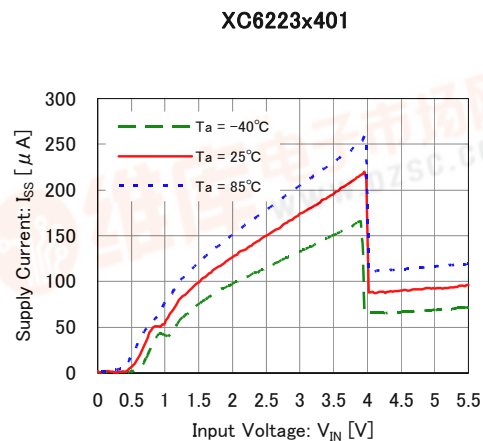
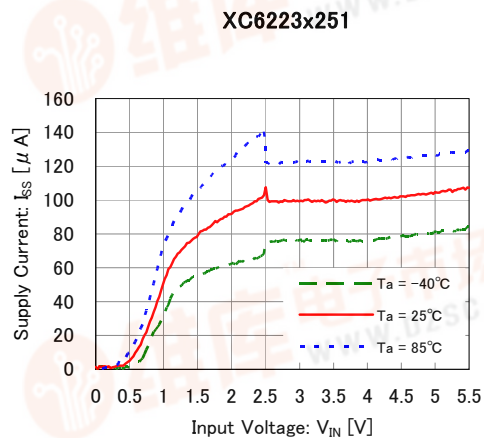
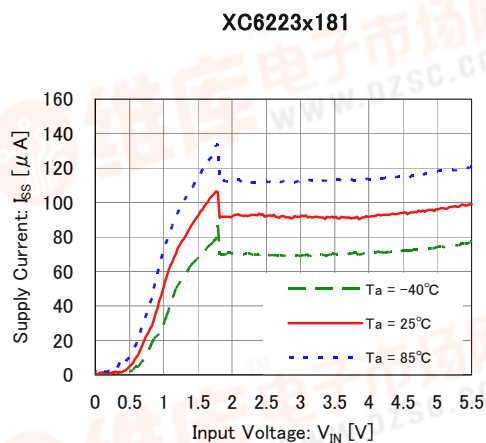
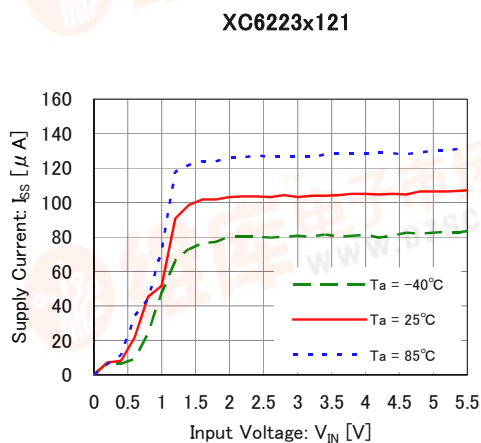



[查询XC6223供应商](#)

## ■ TYPICAL PERFORMANCE CHARACTERISTICS (Continued)

### (5) Output Voltage vs. Ambient Temperature

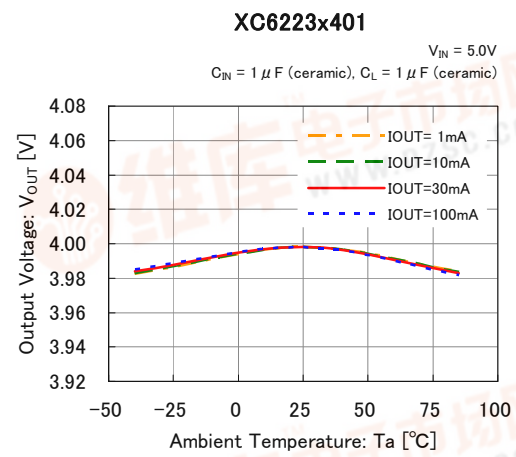
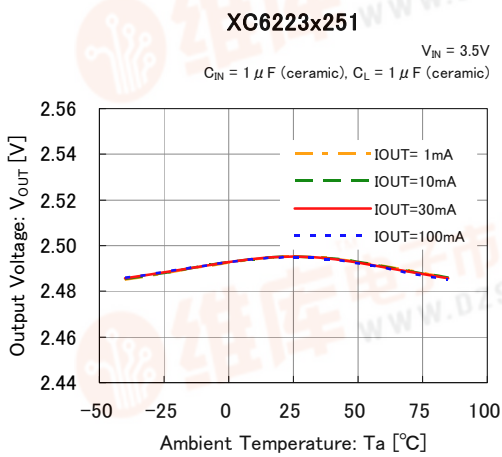
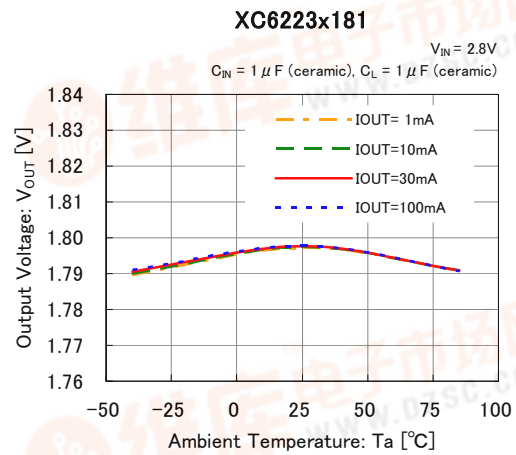
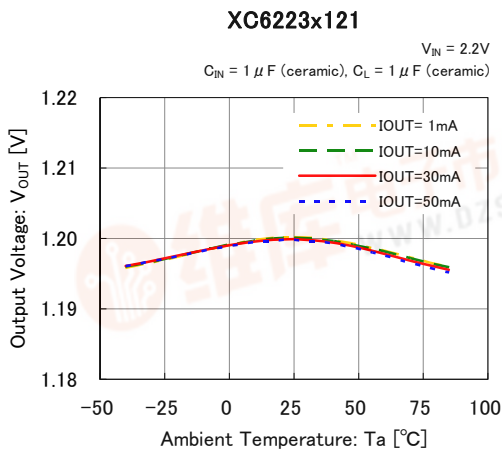

### (6) Rising Response Time

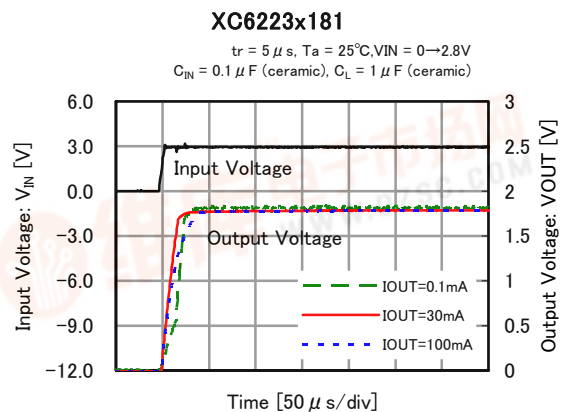
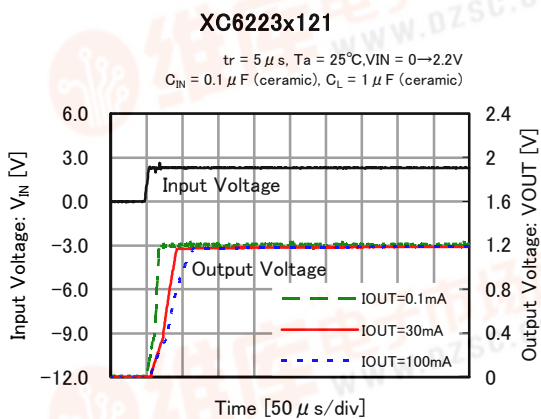

## TYPICAL PERFORMANCE CHARACTERISTICS (Continued)

### (6) Rising Response Time (Continued)

**XC6223x251**

$t_r = 5 \mu s$ ,  $T_a = 25^\circ C$ ,  $V_{IN} = 0 \rightarrow 3.5V$   
 $C_{IN} = 0.1 \mu F$  (ceramic),  $C_L = 1 \mu F$  (ceramic)

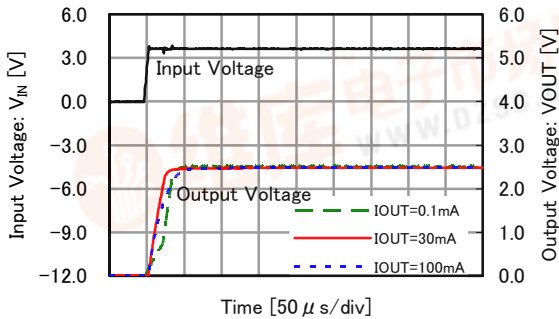

**XC6223x401**

$t_r = 5 \mu s$ ,  $T_a = 25^\circ C$ ,  $V_{IN} = 0 \rightarrow 5.0V$   
 $C_{IN} = 0.1 \mu F$  (ceramic),  $C_L = 1 \mu F$  (ceramic)

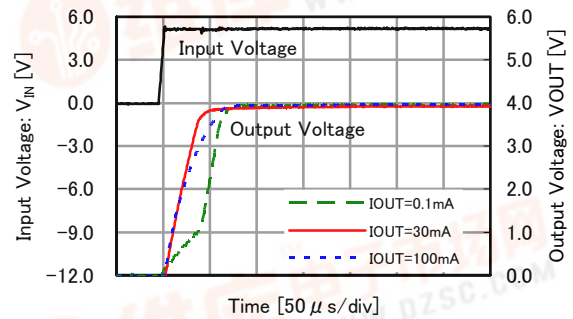

### (7) Input Transient Response

**XC6223x121**

$t_r = t_f = 5 \mu s$ ,  $T_a = 25^\circ C$ ,  $V_{IN} = 2.2V \leftrightarrow 3.2V$   
 $C_{IN} = 0.1 \mu F$  (ceramic),  $C_L = 1.0 \mu F$  (ceramic)

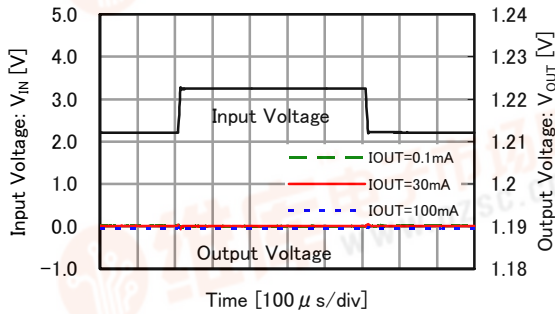

**XC6223x181**

$t_r = t_f = 5 \mu s$ ,  $T_a = 25^\circ C$ ,  $V_{IN} = 2.8V \leftrightarrow 3.8V$   
 $C_{IN} = 0.1 \mu F$  (ceramic),  $C_L = 1.0 \mu F$  (ceramic)

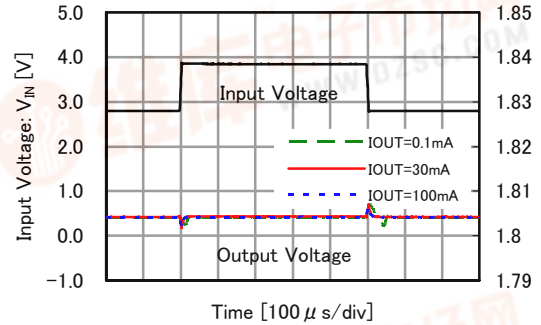

**XC6223x251**

$t_r = t_f = 5 \mu s$ ,  $T_a = 25^\circ C$ ,  $V_{IN} = 3.5V \leftrightarrow 4.5V$   
 $C_{IN} = 0.1 \mu F$  (ceramic),  $C_L = 1.0 \mu F$  (ceramic)

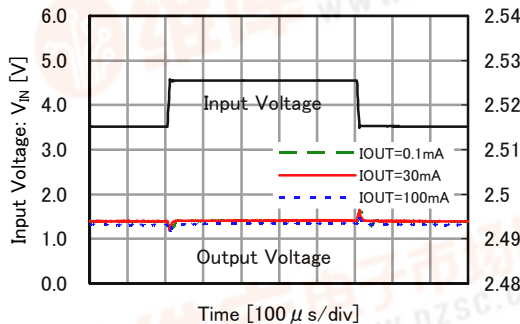

**XC6223x401**

$t_r = t_f = 5 \mu s$ ,  $T_a = 25^\circ C$ ,  $V_{IN} = 4.5V \leftrightarrow 5.5V$   
 $C_{IN} = 0.1 \mu F$  (ceramic),  $C_L = 1.0 \mu F$  (ceramic)

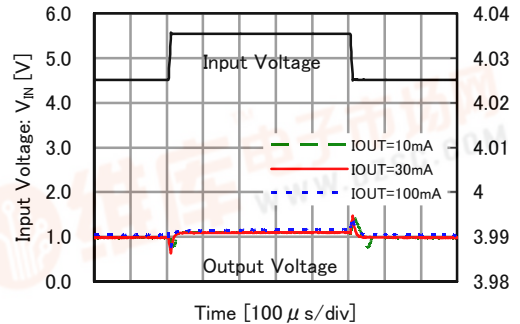

[查询XC6223供应商](#)

## ■ TYPICAL PERFORMANCE CHARACTERISTICS (Continued)

(8) Load Transient Response ( $t_r=t_f=0.5\mu s$ )

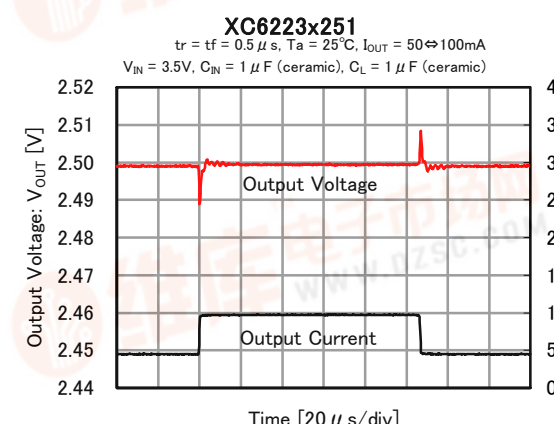
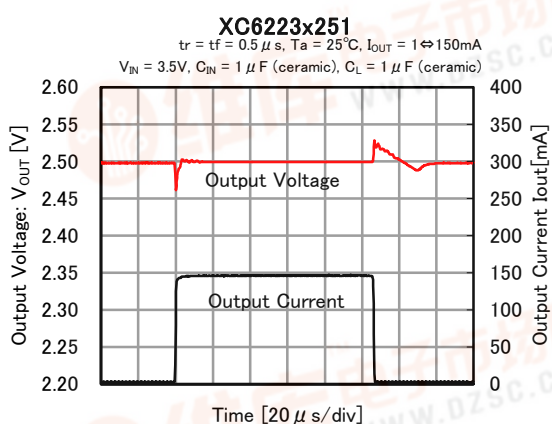
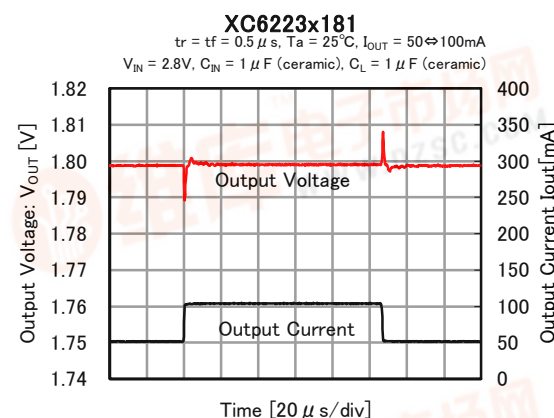
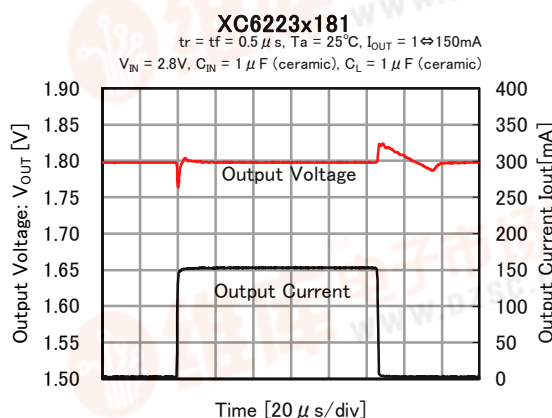
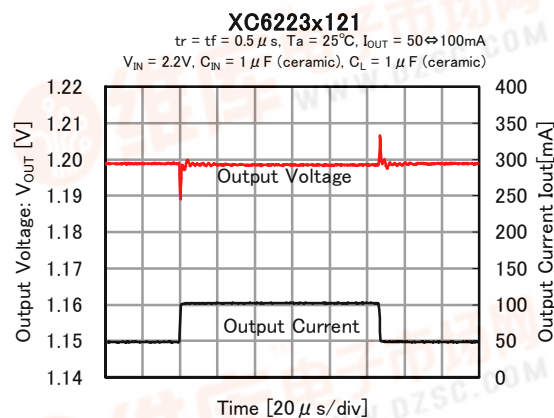
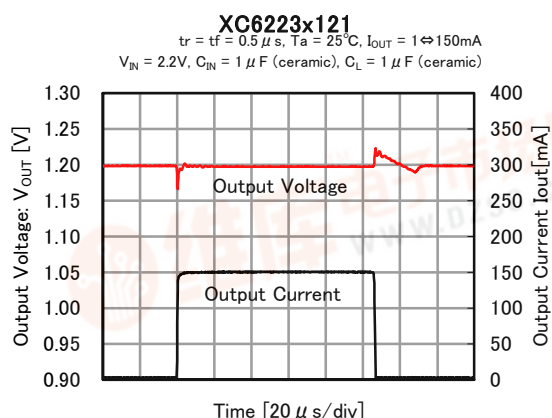

## TYPICAL PERFORMANCE CHARACTERISTICS (Continued)

(8) Load Transient Response ( $t_r=t_f=0.5\mu s$ ) (Continued)

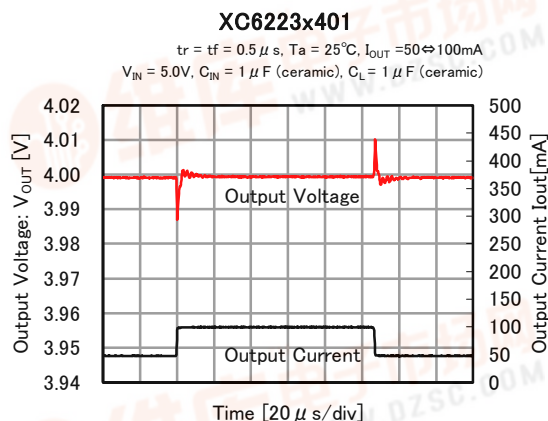
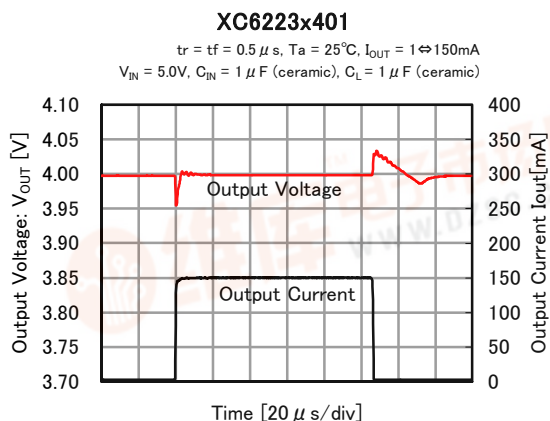

(8) Load Transient Response ( $t_r=t_f=5\mu s$ ) (Continued)

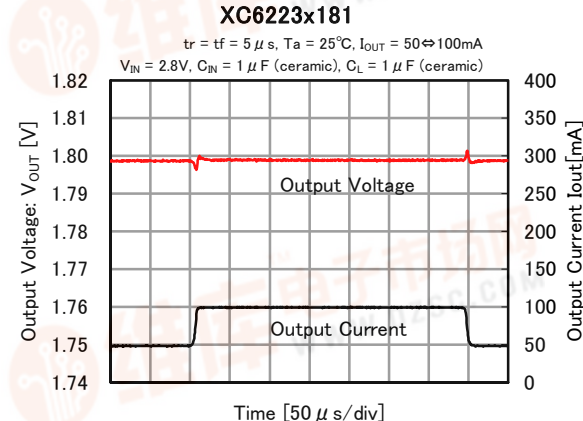
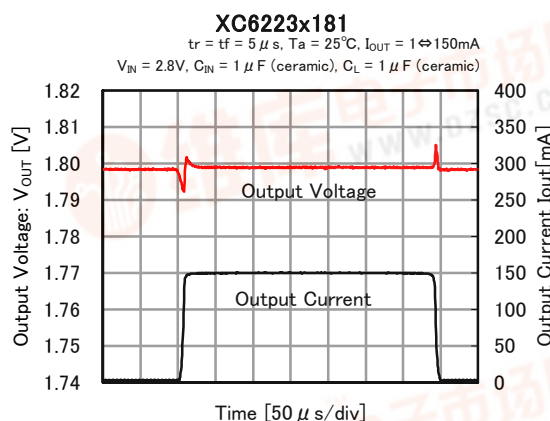
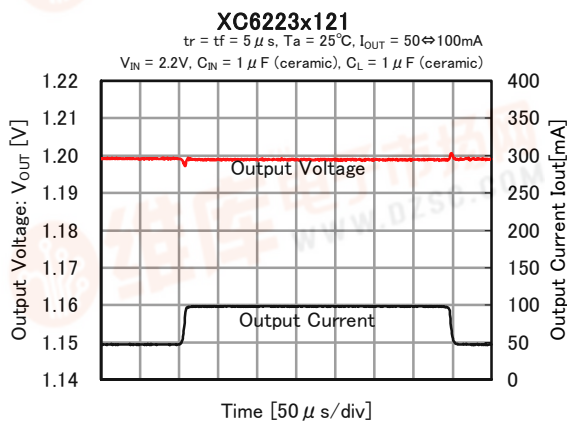
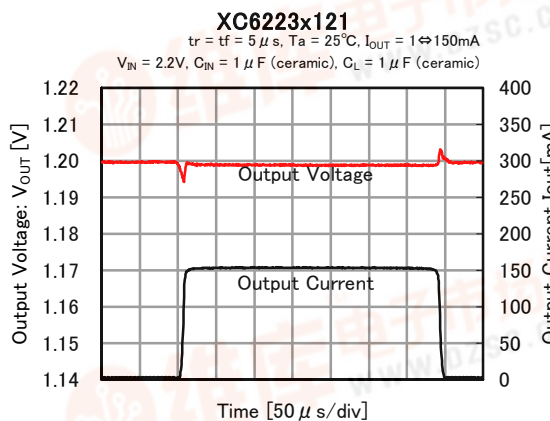

[查询XC6223供应商](#)

## ■ TYPICAL PERFORMANCE CHARACTERISTICS (Continued)

(8) Load Transient Response ( $t_r=t_f=5\mu s$ ) (Continued)

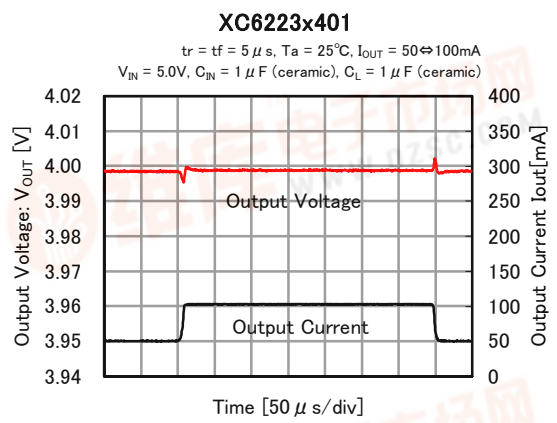
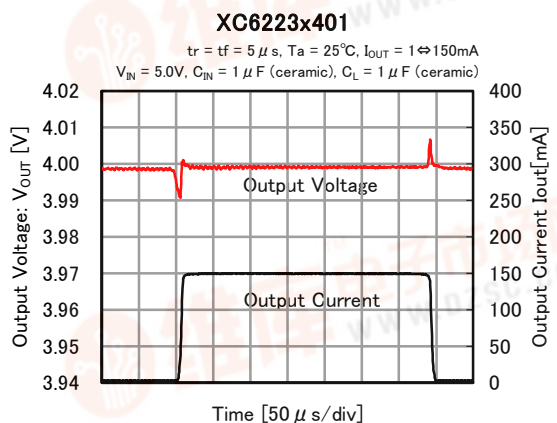
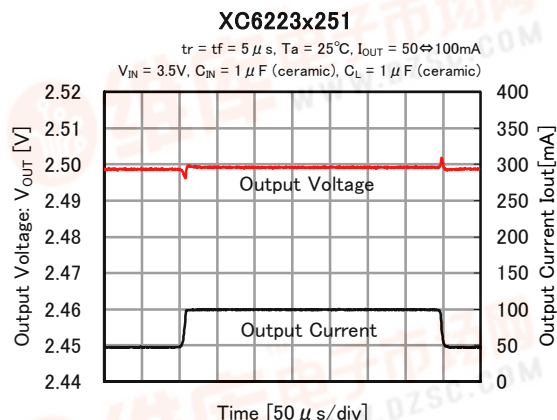
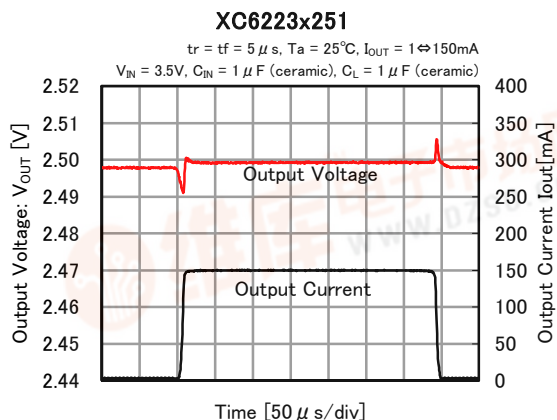

(9) CE Rising Response Time (A,B,C,D Type)

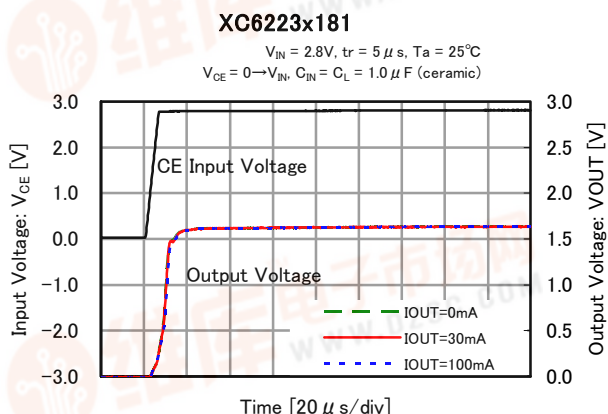
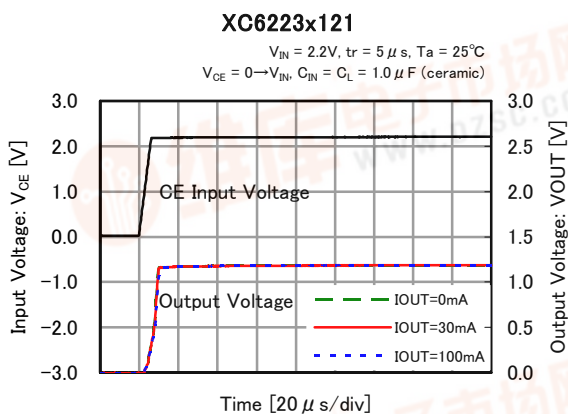

## TYPICAL PERFORMANCE CHARACTERISTICS (Continued)

### (9) CE Rising Response Time (A,B,C,D Type) (Continued)

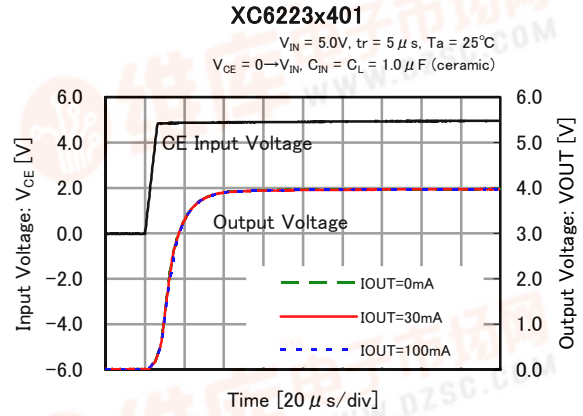
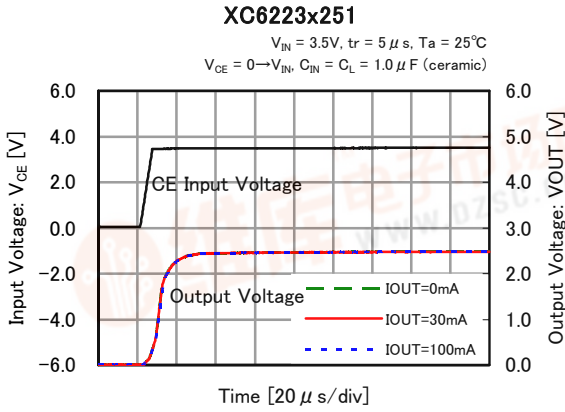

### (9) CE Rising Response Time (E,F,G,H Type) (Continued)

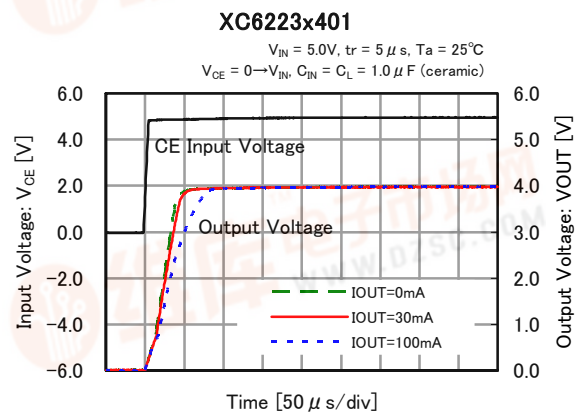
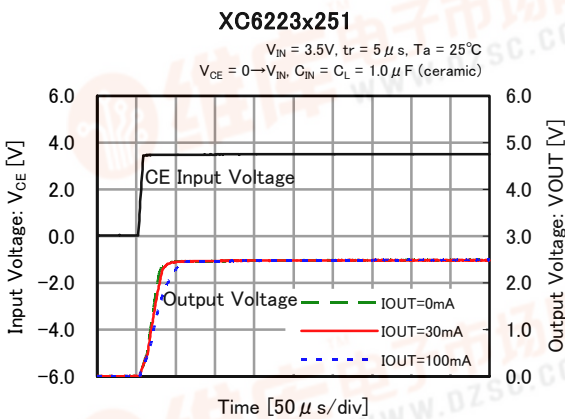
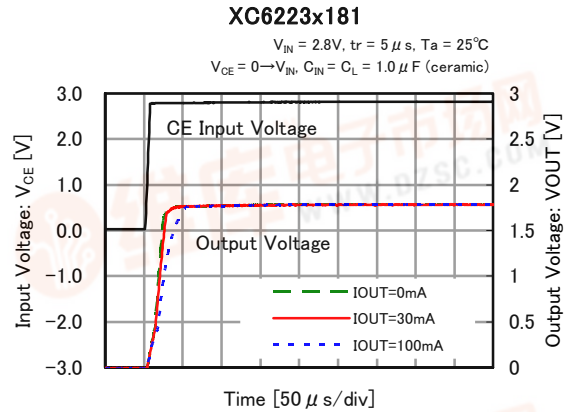
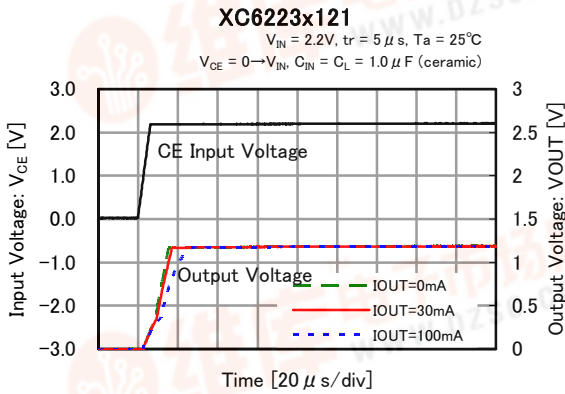

[查询XC6223供应商](#)

## ■ TYPICAL PERFORMANCE CHARACTERISTICS (Continued)

(10) Inrush Current Response Time (E,F,G,H Type)

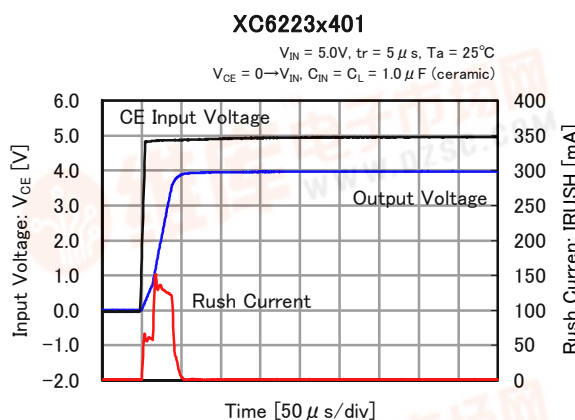
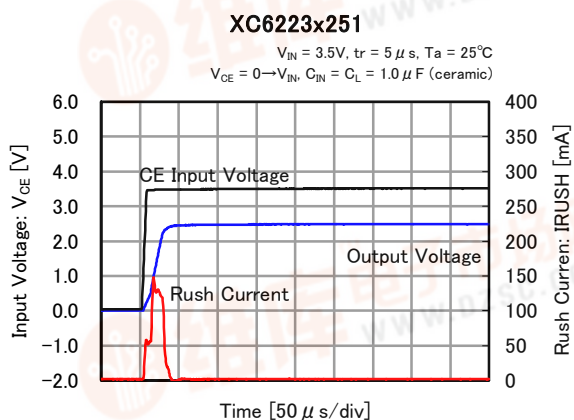
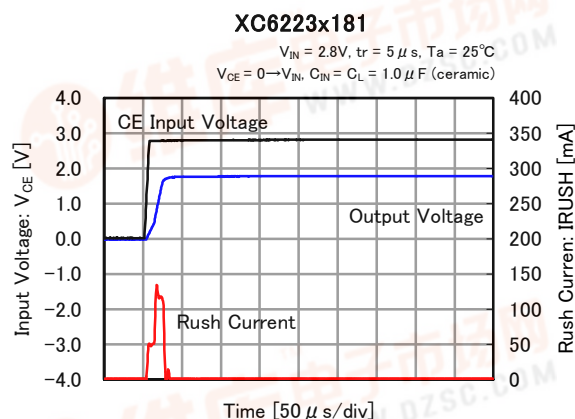
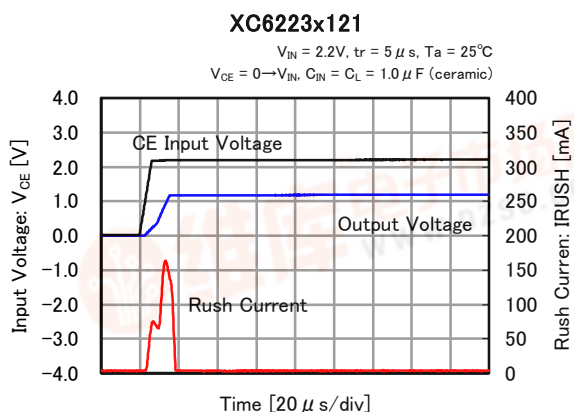

## TYPICAL PERFORMANCE CHARACTERISTICS (Continued)

### (11) Ripple Rejection Rate

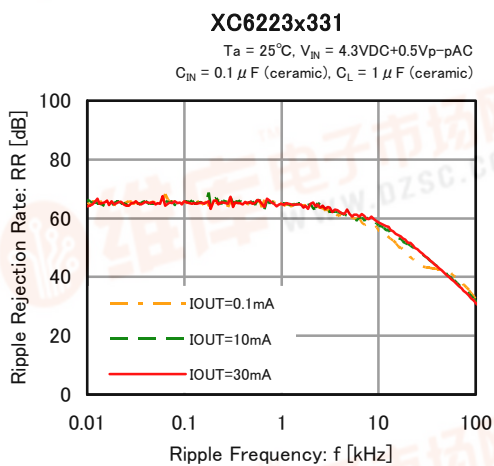
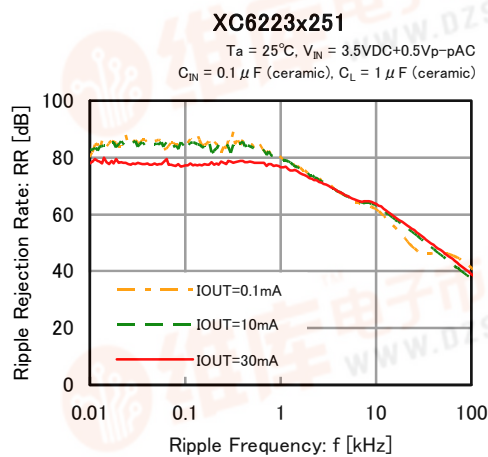
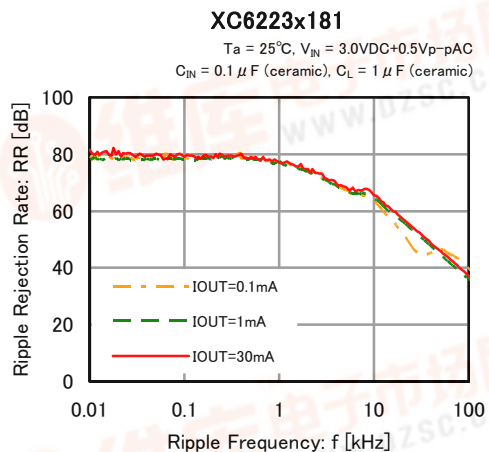
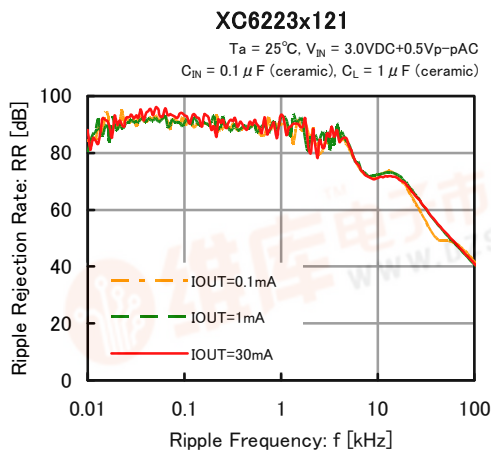



查询XC6223供应商

## PACKAGING INFORMATION

USPQ-4B03  
(unit : mm)

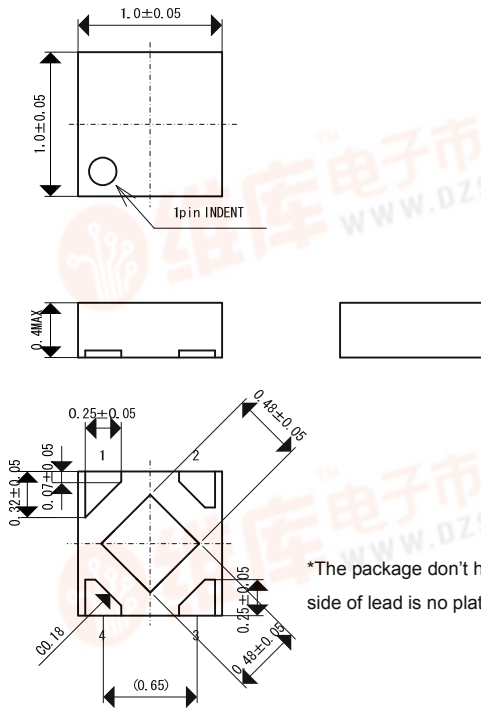

\*The package don't have filet because side of lead is no plating.

USP-4  
(unit : mm)

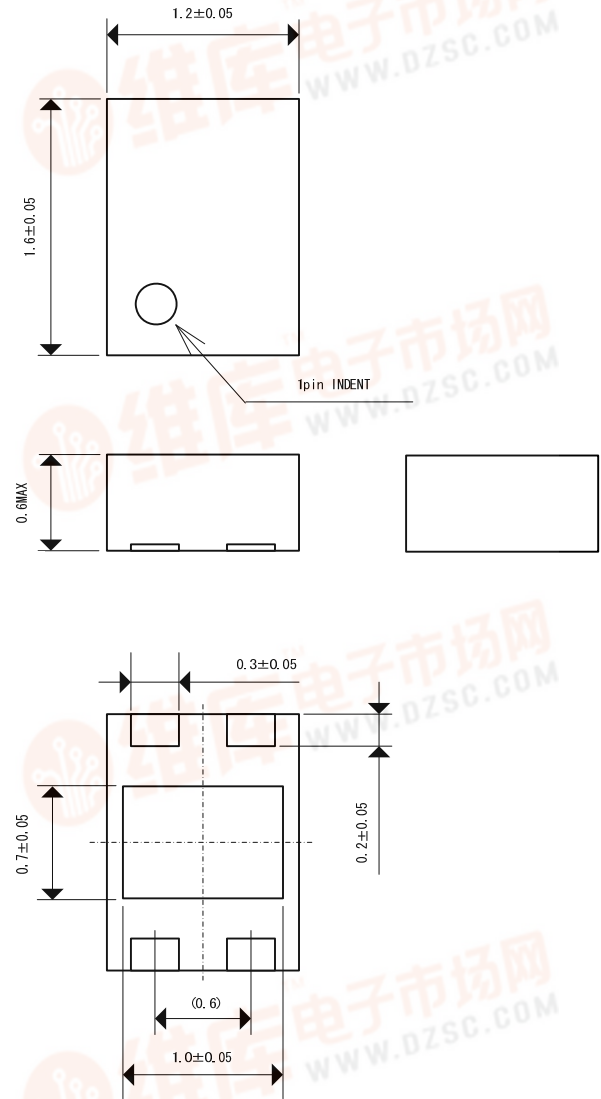

SSOT-24  
(unit : mm)

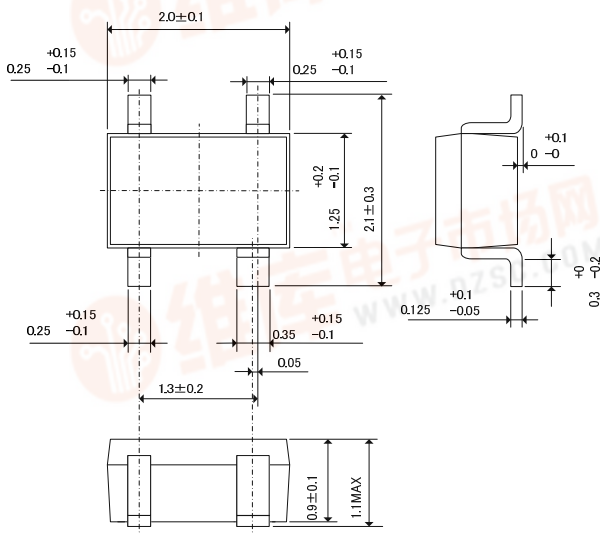

# XC6223 Series

[查询XC6223供应商](#)

## PACKAGING INFORMATION (Continued)

SOT-25  
(unit : mm)

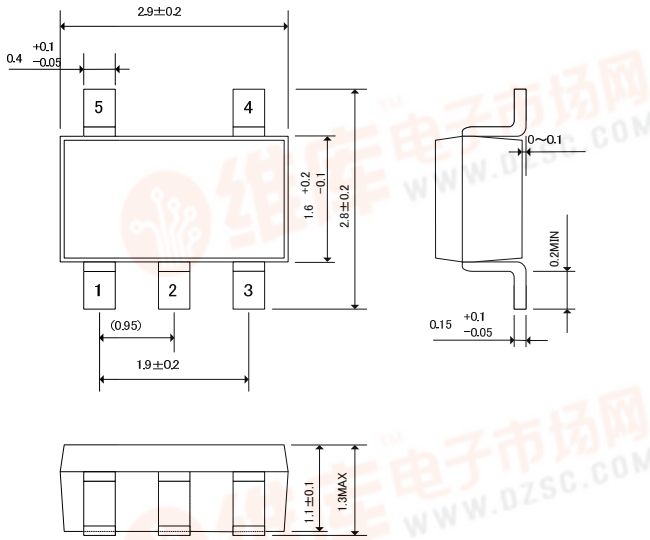

SOT-89-5  
(unit : mm)

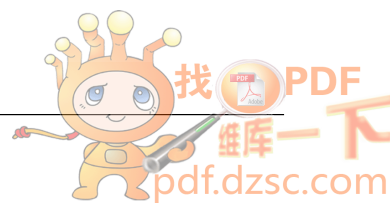
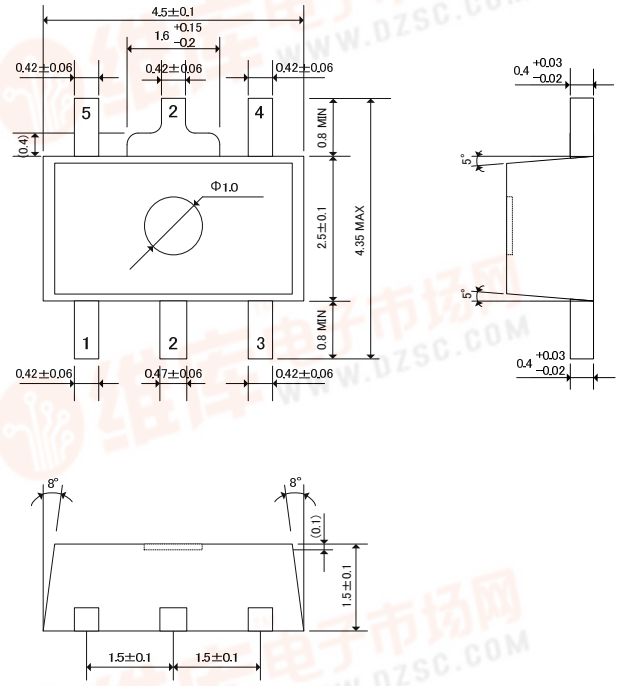

[查询XC6223供应商](#)

**PACKAGING INFORMATION (Continued)**

●USPQ-4B03 Reference Pattern Layout

(unit : mm)

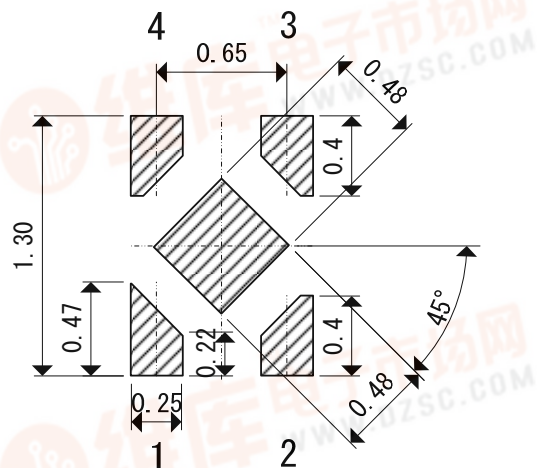

●USPQ-4B03 Reference Metal Mask Design

(unit : mm)

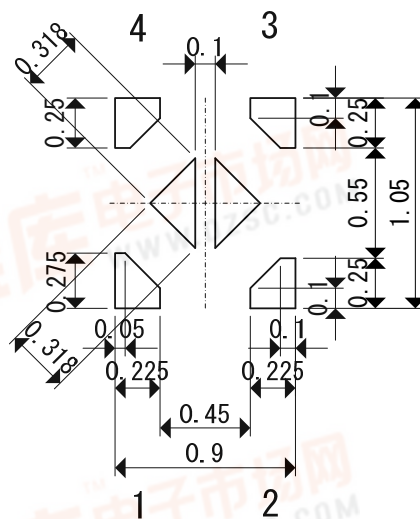

●USP-4 Reference Pattern Layout

(unit : mm)

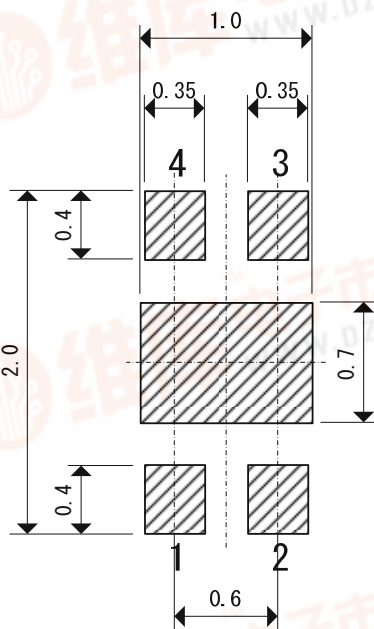

●USP-4 Reference Metal Mask Design

(unit : mm)

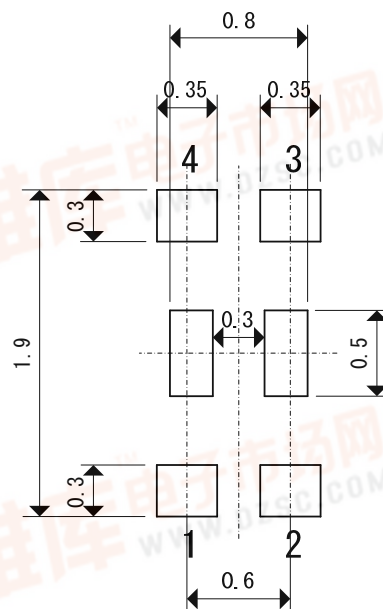

## PACKAGING INFORMATION (Continued)

### ● USPQ-4B03 Power Dissipation

Power dissipation data for the USPQ-4B03 is shown in this page.  
The value of power dissipation varies with the mount board conditions.  
Please use this data as one of reference data taken in the described condition.

#### 1. Measurement Condition (Reference data)

Condition	: Mount on a board
Ambient	: Natural convection
Soldering	: Lead (Pb) free
Board Dimensions	: 40 x 40 mm (1600mm <sup>2</sup> )
Board Structure	: 4 Copper Layers Each layer is connected to the package heat-sink and terminal pin No.1. Each layer has approximately 800mm <sup>2</sup> copper area.
Material	: Glass Epoxy (FR-4)
Thickness	: 1.6 mm
Through-hole	: 4 x 0.8 Diameter

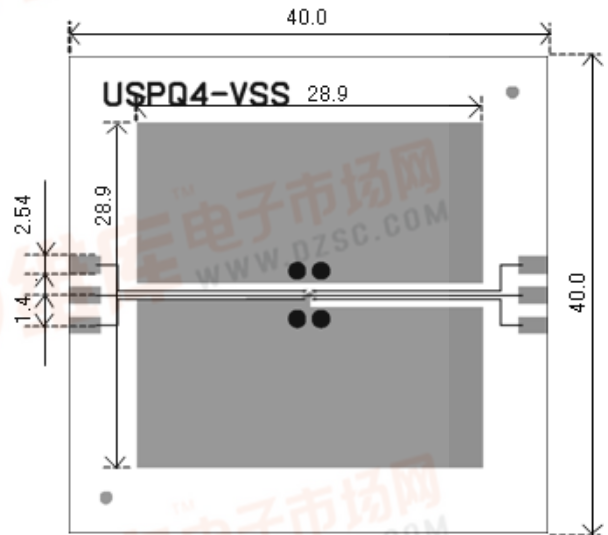

Evaluation Board (Unit: mm)

#### 2. Power Dissipation vs. Ambient temperature

Board Mount ( $T_j \text{ max} = 125^\circ\text{C}$ )

Ambient Temperature ( $^\circ\text{C}$ )	Power Dissipation $P_d$ (mW)	Thermal Resistance ( $^\circ\text{C}/\text{W}$ )
25	550	181.82
85	220	

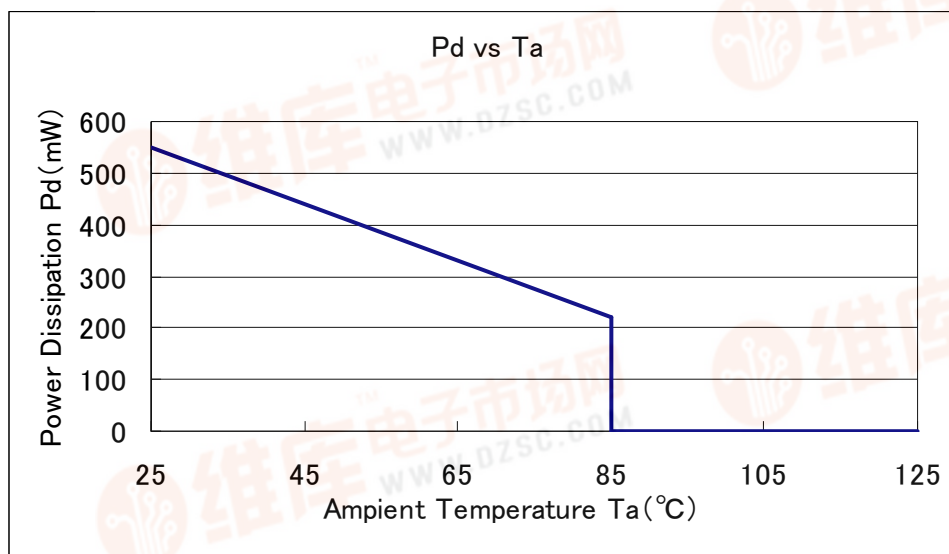

[查询XC6223供应商](#)

## ■ PACKAGING INFORMATION (Continued)

### ● USP-4 Power Dissipation

Power dissipation data for the USP-4 is shown in this page.  
The value of power dissipation varies with the mount board conditions.  
Please use this data as one of reference data taken in the described condition.

#### 1. Measurement Condition (Reference data)

- Condition: Mount on a board
- Ambient: Natural convection
- Soldering: Lead (Pb) free
- Board: Dimensions 40 x 40 mm (1600 mm<sup>2</sup> in one side)  
Copper (Cu) traces occupy 50% of the board area  
In top and back faces  
Package heat-sink is tied to the copper traces
- Material: Glass Epoxy (FR-4)
- Thickness: 1.6 mm
- Through-hole: 4 x 0.8 Diameter

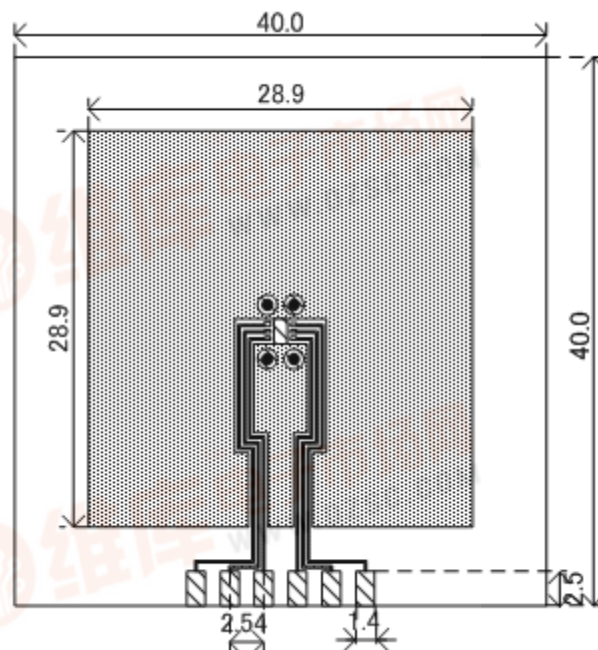

Evaluation Board (Unit: mm)

#### 2. Power Dissipation vs. Ambient temperature

Board Mount ( $T_j \text{ max} = 125^\circ\text{C}$ )

Ambient Temperature ( $^\circ\text{C}$ )	Power Dissipation $P_d$ (mW)	Thermal Resistance ( $^\circ\text{C}/\text{W}$ )
25	1000	100.00
85	400	

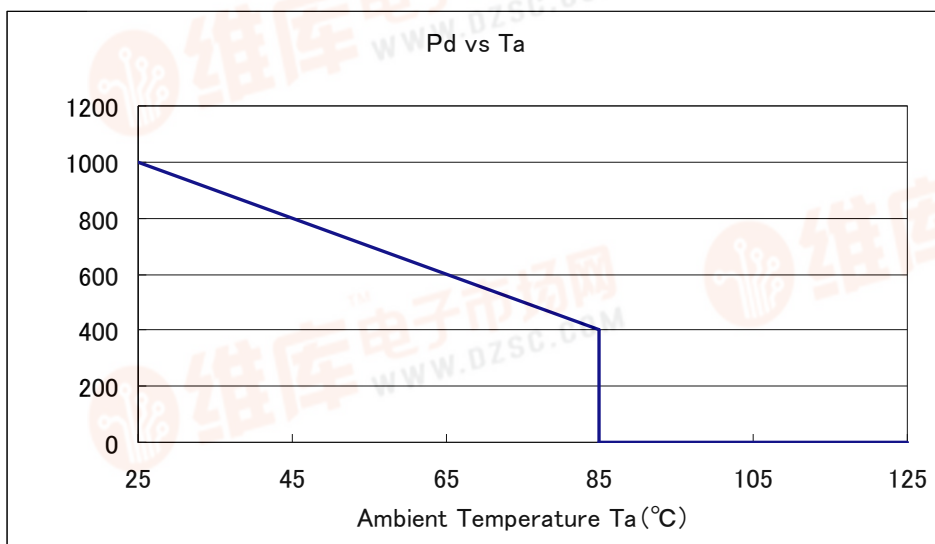

## PACKAGING INFORMATION (Continued)

### ● SSOT-24 Power Dissipation

Power dissipation data for the SSOT-24 is shown in this page.  
The value of power dissipation varies with the mount board conditions.  
Please use this data as one of reference data taken in the described condition.

#### 2. Measurement Condition (Reference data)

- Condition: Mount on a board
- Ambient: Natural convection
- Soldering: Lead (Pb) free
- Board: Dimensions 40 x 40 mm (1600 mm<sup>2</sup> in one side)  
Copper (Cu) traces occupy 50% of the board area  
In top and back faces  
Package heat-sink is tied to the copper traces
- Material: Glass Epoxy (FR-4)
- Thickness: 1.6 mm
- Through-hole: 4 x 0.8 Diameter

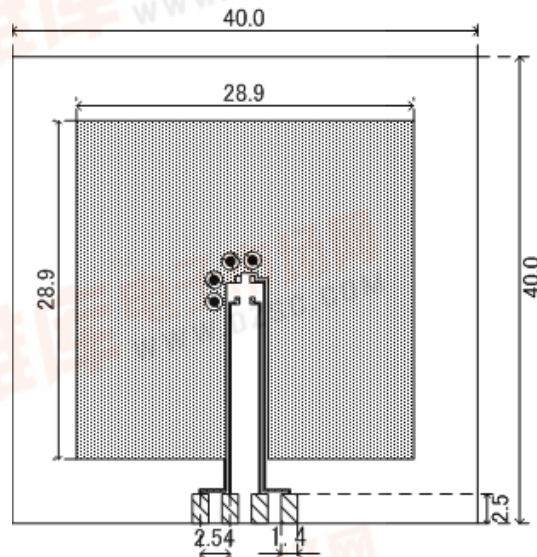

Evaluation Board (Unit: mm)

#### 2. Power Dissipation vs. Ambient temperature

Board Mount ( $T_j \text{ max} = 125^\circ\text{C}$ )

Ambient Temperature ( $^\circ\text{C}$ )	Power Dissipation $P_d$ (mW)	Thermal Resistance ( $^\circ\text{C}/\text{W}$ )
25	500	200.00
85	200	

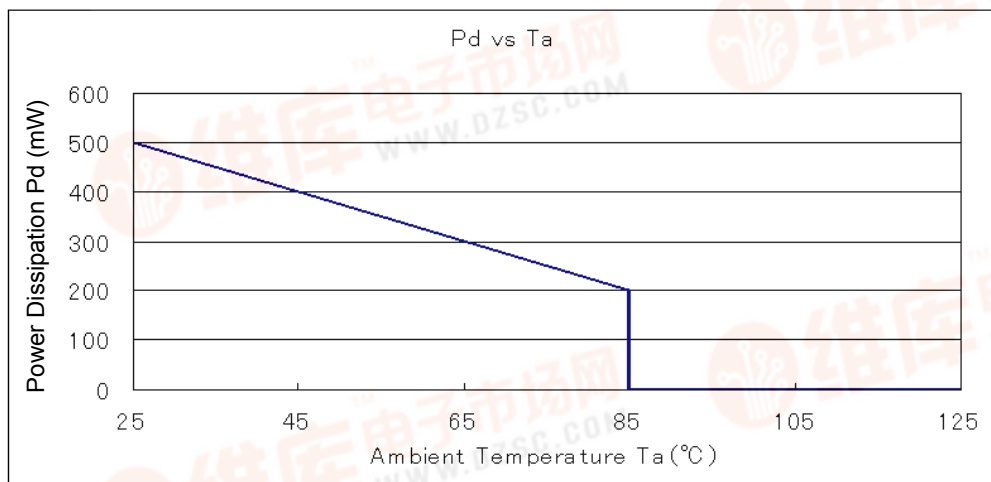

## ■ PACKAGING INFORMATION (Continued)

### ● SOT-25 Power Dissipation

Power dissipation data for the SOT-25 is shown in this page.  
The value of power dissipation varies with the mount board conditions.  
Please use this data as one of reference data taken in the described condition.

#### 1. Measurement Condition (Reference data)

- Condition: Mount on a board
- Ambient: Natural convection
- Soldering: Lead (Pb) free
- Board: Dimensions 40 x 40 mm (1600 mm<sup>2</sup> in one side)  
Copper (Cu) traces occupy 50% of the board area  
In top and back faces  
Package heat-sink is tied to the copper traces  
(Board of SOT-26 is used.)
- Material: Glass Epoxy (FR-4)
- Thickness: 1.6 mm
- Through-hole: 4 x 0.8 Diameter

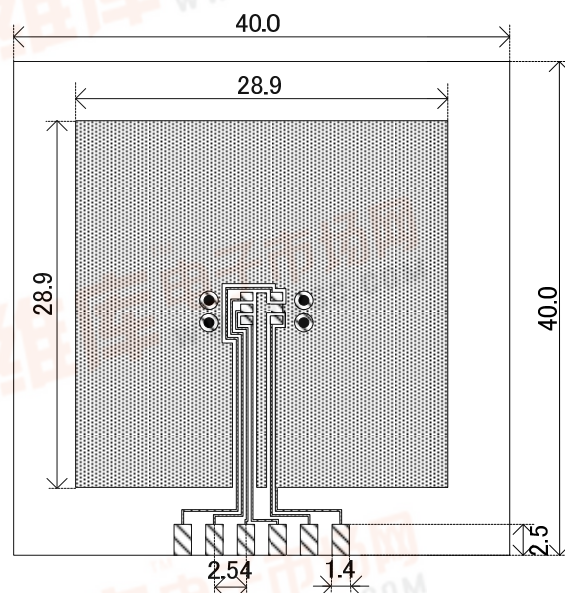

#### 2. Power Dissipation vs. Ambient temperature

Evaluation Board (Unit: mm)

Board Mount (T<sub>j</sub> max = 125°C)

Ambient Temperature (°C)	Power Dissipation Pd (mW)	Thermal Resistance (°C/W)
25	600	166.67
85	240	

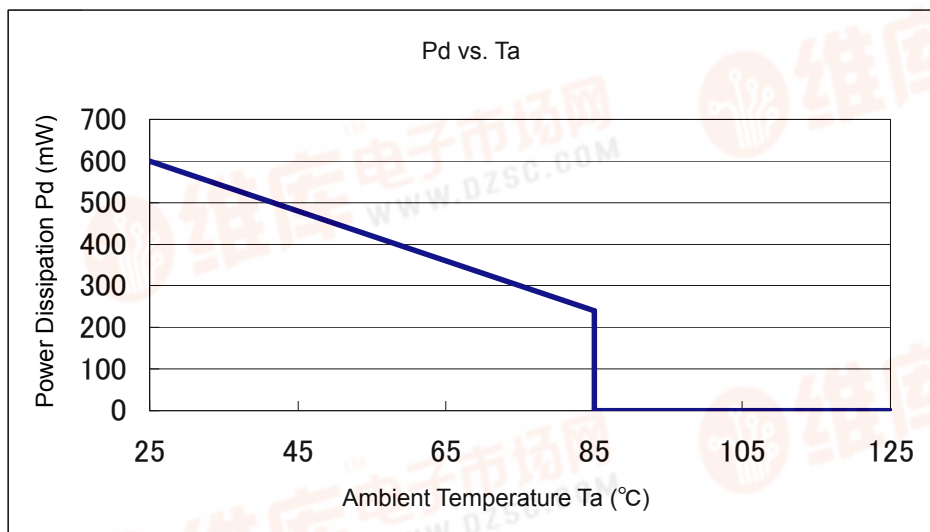

## PACKAGING INFORMATION (Continued)

### SOT-89-5 Power Dissipation

Power dissipation data for the SOT-89-5 is shown in this page.  
The value of power dissipation varies with the mount board conditions.  
Please use this data as one of reference data taken in the described condition.

#### 1. Measurement Condition (Reference data)

- Condition: Mount on a board
- Ambient: Natural convection
- Soldering: Lead (Pb) free
- Board: Dimensions 40 x 40 mm (1600 mm<sup>2</sup> in one side)  
Copper (Cu) traces occupy 50% of the board area  
In top and back faces  
Package heat-sink is tied to the copper traces
- Material: Glass Epoxy (FR-4)
- Thickness: 1.6 mm
- Through-hole: 5 x 0.8 Diameter

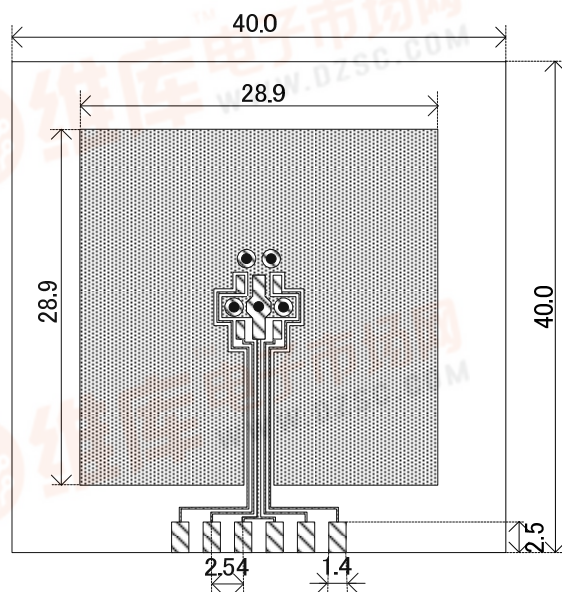

Evaluation Board (Unit: mm)

#### 2. Power Dissipation vs. Operating temperature

Board Mount ( $T_j \text{ max} = 125^\circ\text{C}$ )

Ambient Temperature ( $^\circ\text{C}$ )	Power Dissipation $P_d$ (mW)	Thermal Resistance ( $^\circ\text{C}/\text{W}$ )
25	1300	76.92
85	520	

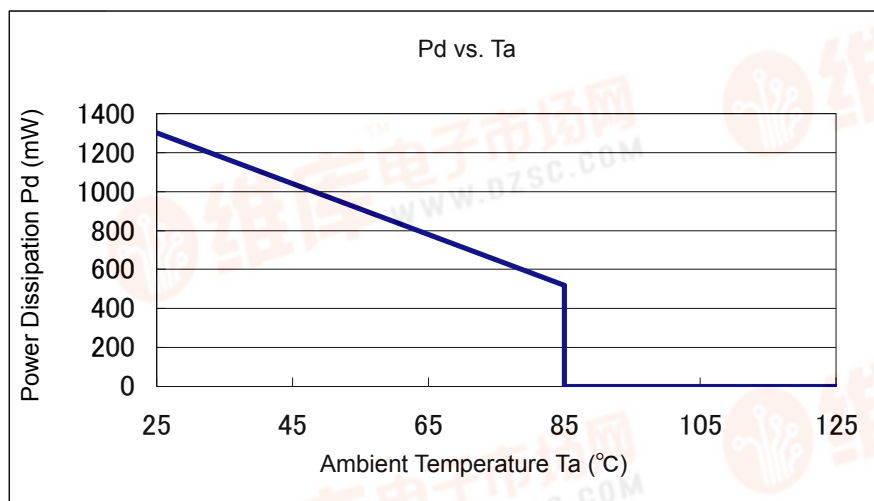



[查询XC6223供应商](#)

## MARKING RULE

●USPQ-4B03

① represents type of regulator and output voltage range.

MARK			PRODUCT SERIES
OUTPUT VOLTAGE 0.1V INCREMENTS		OUTPUT VOLTAGE 0.05V INCREMENTS	
VOLTAGE=1.2~3.9V	VOLTAGE =4.0V	VOLTAGE =1.25~3.95V	
0	H	8	XC6223A****
1		9	XC6223B****
2		A	XC6223C****
3		B	XC6223D****
4		C	XC6223E****
5		D	XC6223F****
6		E	XC6223G****
7		F	XC6223H****

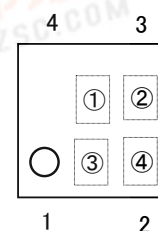

USPQ-4B03  
(TOP VIEW)

② represents output voltage.

VOLTAGE=1.2~3.95[V]

MARK	OUTPUT VOLTAGE (V)		MARK	OUTPUT VOLTAGE (V)	
0	-	-	F	2.50	2.55
1	-	-	H	2.60	2.65
2	1.20	1.25	K	2.70	2.75
3	1.30	1.35	L	2.80	2.85
4	1.40	1.45	M	2.90	2.95
5	1.50	1.55	N	3.00	3.05
6	1.60	1.65	P	3.10	3.15
7	1.70	1.75	R	3.20	3.25
8	1.80	1.85	S	3.30	3.35
9	1.90	1.95	T	3.40	3.45
A	2.00	2.05	U	3.50	3.55
B	2.10	2.15	V	3.60	3.65
C	2.20	2.25	X	3.70	3.75
D	2.30	2.35	Y	3.80	3.85
E	2.40	2.45	Z	3.90	3.95

VOLTAGE=4.0[V]

PRODUCT SERIES	MARK
XC6223A****	0
XC6223B****	1
XC6223C****	2
XC6223D****	3
XC6223E****	4
XC6223F****	5
XC6223G****	6
XC6223H****	7

③④ represents production lot number.

01 to 09, 0A to 0Z, 11 to 9Z, A1 to A9, AA to Z9, ZA to ZZ in order.

(G, I, J, O, Q, W excepted)

\*No character inversion used.

## MARKING RULE (Continued)

●SSOT-24 (with bar)

① represents type of regulator and output voltage range.

MARK			PRODUCT SERIES
OUTPUT VOLTAGE 0.1V INCREMENTS		OUTPUT VOLTAGE 0.05V INCREMENTS	
VOLTAGE =1.2~2.9V	VOLTAGE =3.0~4.0V	VOLTAGE =1.25~3.95V	
B	3	8	XC6223A****
C	5	9	XC6223B****
D	7	S	XC6223C****
E	A	T	XC6223D****
K	F	U	XC6223E****
L	H	V	XC6223F****
M	P	X	XC6223G****
N	Z	Y	XC6223H****

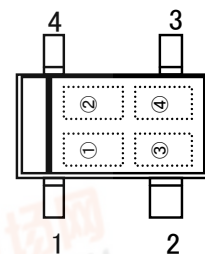

SSOT-24(with bar)  
(TOP VIEW)

② represents output voltage.

MARK	OUTPUT VOLTAGE (V)				MARK	OUTPUT VOLTAGE (V)			
0	-	-	-	-	F	2.50	3.20	-	2.55
1	-	-	-	-	H	2.60	3.30	-	2.65
2	1.20	-	-	1.25	K	2.70	3.40	-	2.75
3	1.30	-	-	1.35	L	2.80	3.50	-	2.85
4	1.40	-	-	1.45	M	2.90	3.60	-	2.95
5	1.50	-	-	1.55	N	-	-	-	3.05
6	1.60	-	-	1.65	P	-	3.70	-	3.15
7	1.70	-	-	1.75	R	-	3.80	-	3.25
8	1.80	-	-	1.85	S	-	3.90	-	3.35
9	1.90	-	-	1.95	T	-	4.00	-	3.45
A	2.00	-	-	2.05	U	-	-	-	3.55
B	2.10	-	-	2.15	V	-	-	-	3.65
C	2.20	-	-	2.25	X	-	-	-	3.75
D	2.30	3.00	-	2.35	Y	-	-	-	3.85
E	2.40	3.10	-	2.45	Z	-	-	-	3.95

③④ represents production lot number.

01 to 09, 0A to 0Z, 11 to 9Z, A1 to A9, AA to Z9, ZA to ZZ in order.

(G, I, J, O, Q, W excepted)

\*No character inversion used.

[查询XC6223供应商](#)

## MARKING RULE (Continued)

●SOT-25, SOT-89-5, USP-4

① represents product series

MARK	PRODUCT SERIES
9	XC6223*****

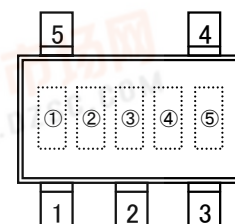

SOT-25  
(TOP VIEW)

② represents type of regulator.

MARK			PRODUCT SERIES
OUTPUT VOLTAGE 0.1V INCREMENTS		OUTPUT VOLTAGE 0.05V INCREMENTS	
VOLTAGE =1.2~3.9V	VOLTAGE =4.0V	VOLTAGE =1.25~3.95V	
C	D	E	XC6223A****
F	H	K	XC6223B****
L	M	N	XC6223C****
P	R	S	XC6223D****
T	U	V	XC6223E****
X	Y	Z	XC6223F****
0	1	2	XC6223G****
3	4	5	XC6223H****

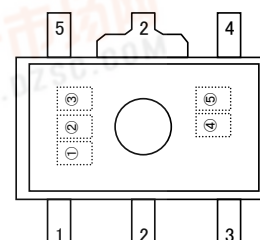

SOT-89-5  
(TOP VIEW)

③ represents output voltage.

MARK	OUTPUT VOLTAGE (V)			MARK	OUTPUT VOLTAGE (V)				
	-	4.00	-		2.50	-	2.55	-	
0	-	4.00	-	F	2.50	-	2.55	-	
1	-	-	-	H	2.60	-	2.65	-	
2	1.20	-	1.25	-	K	2.70	-	2.75	-
3	1.30	-	1.35	-	L	2.80	-	2.85	-
4	1.40	-	1.45	-	M	2.90	-	2.95	-
5	1.50	-	1.55	-	N	3.00	-	3.05	-
6	1.60	-	1.65	-	P	3.10	-	3.15	-
7	1.70	-	1.75	-	R	3.20	-	3.25	-
8	1.80	-	1.85	-	S	3.30	-	3.35	-
9	1.90	-	1.95	-	T	3.40	-	3.45	-
A	2.00	-	2.05	-	U	3.50	-	3.55	-
B	2.10	-	2.15	-	V	3.60	-	3.65	-
C	2.20	-	2.25	-	X	3.70	-	3.75	-
D	2.30	-	2.35	-	Y	3.80	-	3.85	-
E	2.40	-	2.45	-	Z	3.90	-	3.95	-

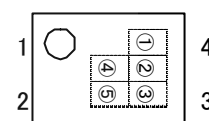

USP-4  
(TOP VIEW)

④⑤ represents production lot number.

01 to 09, 0A to 0Z, 11 to 9Z, A1 to A9, AA to Z9, ZA to ZZ in order.

(G, I, J, O, Q, W excepted)

\*No character inversion used.

1. The products and product specifications contained herein are subject to change without notice to improve performance characteristics. Consult us, or our representatives before use, to confirm that the information in this datasheet is up to date.
2. We assume no responsibility for any infringement of patents, patent rights, or other rights arising from the use of any information and circuitry in this datasheet.
3. Please ensure suitable shipping controls (including fail-safe designs and aging protection) are in force for equipment employing products listed in this datasheet.
4. The products in this datasheet are not developed, designed, or approved for use with such equipment whose failure of malfunction can be reasonably expected to directly endanger the life of, or cause significant injury to, the user.  
(e.g. Atomic energy; aerospace; transport; combustion and associated safety equipment thereof.)
5. Please use the products listed in this datasheet within the specified ranges.  
Should you wish to use the products under conditions exceeding the specifications, please consult us or our representatives.
6. We assume no responsibility for damage or loss due to abnormal use.
7. All rights reserved. No part of this datasheet may be copied or reproduced without the prior permission of TOREX SEMICONDUCTOR LTD.

**TOREX SEMICONDUCTOR LTD.**